

Medium-voltage power distribution and control systems > Switchgear >

Metal-enclosed switchgear— MVS medium-voltage 27 kV load interrupter switch

Contents

General Description	8.2-2
MVS Load Interrupter Switchgear	8.2-2
Devices	8.2-6
Switch Technical Data	8.2-6
Motor Operated MVS	8.2-7
Metering	8.2-8
Automatic Transfer Control	8.2-9
Surge Protection	8.2-10
System Options	8.2-11
Layouts and Dimensions	8.2-13
MVS Layouts	8.2-13
Application Data	8.2-17
Weights	8.2-17



Powering Business Worldwide

MVS Load Interrupter Switchgear

Eaton's MVS Load Interrupter Switchgear is an integrated assembly of switches, bus and fuses is constructed for medium-voltage circuit protection. All major components are manufactured by Eaton, establishing one source of responsibility for the equipment's performance and ensuring high standards in quality, coordination, reliability and service.

A complete line of Eaton switches and fuses is available:

- 27 kV voltage class
- 600 A continuous load interrupting ratings
- Non-fused or fused with current limiting or boric acid-type fuses
- Manual or motor operated
- Indoor or outdoor non-walk-in enclosures
- Single switches and transformer primary switches
- Duplex loadbreak switch arrangements for selection of alternate feeds
- Lineups with main bus
- Standard arrangements with automatic transfer control systems (two sources feeding one bus or two sources feeding two buses on a split bus with tie switch)

Standard design configurations for:

- NEMA® pads for cable lugs
- Surge arresters
- Instrument transformers
- Control power transformers
- Power Xpert® and IQ electronic metering
- Other auxiliary equipment



Outdoor Duplex with Customer Metering

Application Description

Eaton's Load Interrupter Type MVS metal-enclosed switchgear provides safe, reliable switching and fault protection for medium-voltage circuits rated to 27 kV. The MVS switch is ideal for applications where high duty cycle operation is not required.

MVS switchgear has the advantage of low initial cost inherent in switch designs while offering the characteristics most vital to safety and coordination.

The MVS switch's quick-make, quick-break mechanism provides full-load current interrupting capability while fuses provide accurate, permanently calibrated short circuit detecting and interrupting capabilities. Visibility of actual blade position improves safety by giving positive assurance of circuit de-energization.

Standards and Certifications

Eaton's MVS load interrupter switchgear meets or exceeds the requirements of the following industry standards:

- IEEE® Standard C37.20.3
- ANSI C37.57
- NEMA SG5
- Canadian Standard CAN/CSA® C22.2 No. 31

Type MVS switches meet or exceed the requirements of the following industry standards:

- IEEE Standard C37.20.4
- ANSI C37.58
- ANSI C37.22
- NEMA SG6
- Canadian Standards CAN/CSA C22.2 No. 193 and CAN/CSA C22.2 No. 58

Load interrupter switches should not be used to interrupt load currents above their interrupting rating of 600 A, as they are not designed nor tested for interrupting fault currents on electrical systems. Optional fuses can be provided for phase overcurrent protection.

Table 8.2-1. Switchgear Assembly Main Cross Bus Ratings

Rated Maximum Voltage	Rated BIL	Rated Main Bus Current	Rated Momentary Short-Circuit Current		Rated Short-Time Short-Circuit Current (2 sec.)
			kA Asym	kA Peak	
kV	kV	Amperes	kA Asym	kA Peak	kA rms Sym.
27	125	600–1200	40	65	25
27	125	600–1200	64	104	40

Switch Mechanism

The quick-make, quick-break mechanism uses a heavy-duty coil spring that provides powerful opening and closing action. To close the switch, the handle is inserted into the spring charging cam, then rotated upward through an angle of 120 degrees. This action charges the operating spring, as the mechanism is forced past toggle. The stored energy of the spring is released and transferred to the main shaft that snaps the switch closed.

As a result of the over-toggle action, the blades are moved independently of the operator. It is impossible to operate the switch into an intermediate position.

To open the switch, the handle is inserted into the spring charging cam and rotated downward through 120 degrees resulting in charging of the operating spring, then releasing its stored energy in similar sequence.

Quick-Break DE-ION Arc Interruption

With the switch closed, both main and auxiliary (flicker) blades are closed, and all of the current flows through the main blades. The flicker blades are in the closed position in the arc chutes, but are past the arcing contacts and thus carry no current. As the main blades open, current is transferred momentarily to the flicker blades, which are held in the arc chutes by high pressure contact fingers. There is no arcing at the main blades.

When the main blades reach a pre-determined angle of opening, a stop post on the main blades prevents further angular movement between the main and flicker blades. This starts the flicker blades out of the high pressure contacts in the arc chutes and as contacts are broken, the flicker blades are snapped into position by their torsion springs.

The heat of the arc, meanwhile, releases a blast of de-ionizing gas from the gas-generating material of the arc chute. This combination of quick-break and DE-ION action quickly extinguishes the arc and the circuit is safely de-energized.

A non-fused switch has the ability to close and latch four times when rated 40 kA, and one time when rated 61 kA, and continue to carry rated current thus adding a large margin of integrity to the electrical system.

Bus Insulation System

All bus runs are supported using a high strength and high creep, finned support providing in excess of 24.00 inches (609.6 mm) for 27 kV, of creep distance between phases and ground. The molded high track-resistant fins are constructed as standard of Aramid nylon or optional Cycloaliphatic epoxy.

- Significantly superior bus bracing than standoff type A20 insulators
- Significantly increased creep distance phase-to-phase and phase-to-ground
- Improved endurance from fault incidents
- Minimizes bus system failures due to tracking
- Eliminates additional ground planes in the switchgear for bus supporting systems



Bus Support

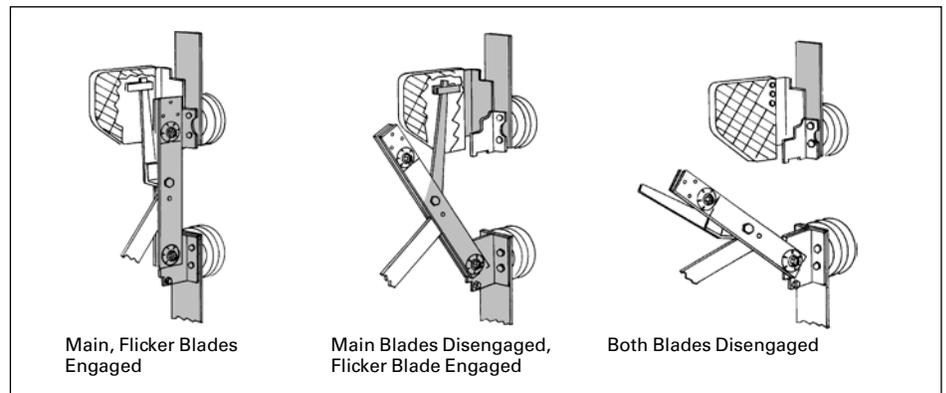

Figure 8.2-1. Switch Operation

Duplex Switch Configuration

Two MVS load interrupter switch sections can be used to provide cost-effective source selectivity with a common load side bus feeding one load (fused or nonfused). Key interlocks are a standard feature provided to permit only one switch to be closed at a time and prevent opening any switch door unless both switches are open.

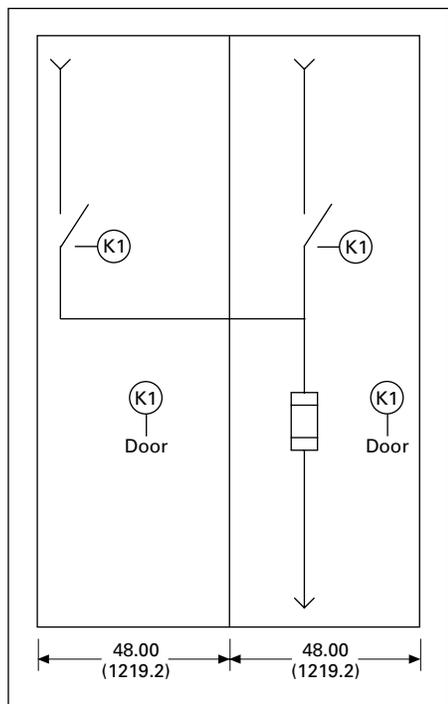

Figure 8.2-2. Typical Duplex Switch Configuration with One K1 Key—Dimensions in Inches (mm)

Loadbreak Switch with Grounding Jaw

The loadbreak switch can be supplied with optional grounding jaws for automatic grounding of the load circuit. When the switch is opened, the switch main blades engage grounding jaws to ground the load circuit. **This feature cannot be used in a duplex switch configuration.** The ground jaw option is available at 27 kV. It is meant for applying a static ground, and is not rated for carrying fault currents.

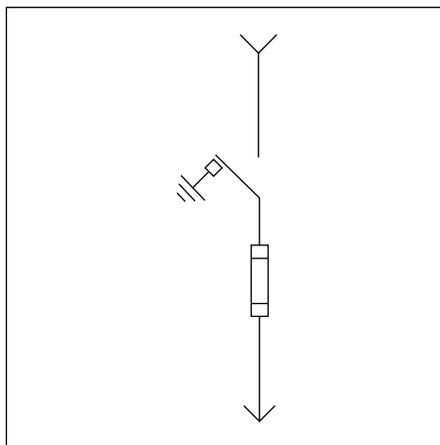

Figure 8.2-3. Typical Feeder Switch with Optional Grounding Jaw (27 kV)

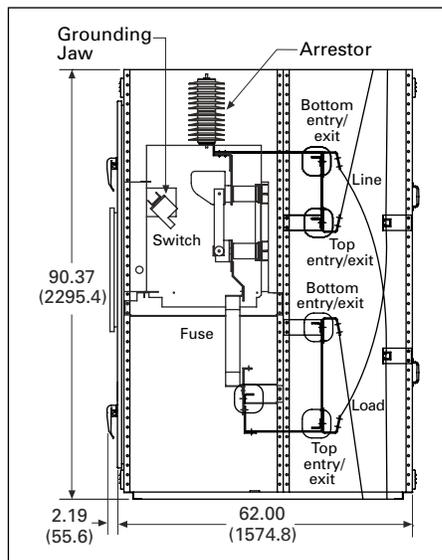
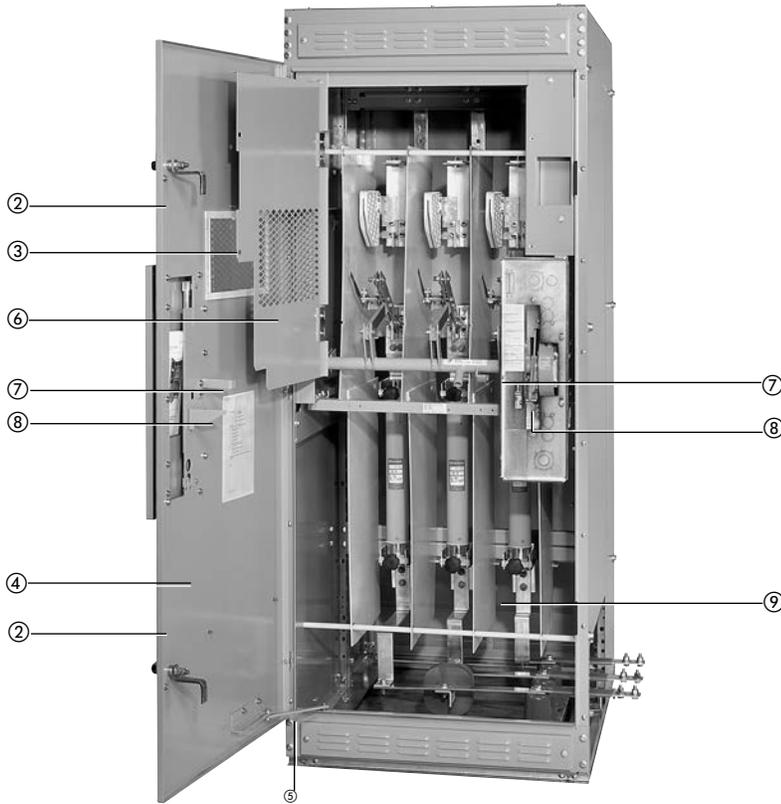

Figure 8.2-4. Typical Section View of Feeder Switch with Optional Grounding Jaws—Dimensions in Inches (mm)

Construction



Typical Switch with Front Door Open

- ① **Switch Mechanism**
Quick-make, quick-break stored energy operation.

The opening and closing of the switch blades is done by the operating spring. An operator's actions only charge and release the operating spring.

The switch blades cannot be operated in any intermediate position. During the closing operation, full clearance between blades and stationary contacts is maintained until the switch mechanism goes over toggle.

The switch mechanism has only metal-to-metal linkage—no chains or cables are used.

Arc interruption takes place between copper-tungsten tipped auxiliary (flicker) blade and arcing contacts with a DE-ION® arc chute; no arcing takes place between the main blades and the stationary contacts to prolong the life of the main blades.

Blow-out forces cannot be transmitted to the operating handle.

- ② **Provisions for Padlocking Door**
Handle not visible in the photo.
- ③ **Inspection Window**
A large 8.00-inch x 16.00-inch (203.2 x 406.4 mm) gasketed, rectangular, high impact viewing window permits full view of the position of all three switch blades through the closed door.
- ④ **Full Height Main Door**
The door has a return flange and two rotary latch-type handles to provide latching members held in shear. It closes over a projecting frame.
- ⑤ **Foot-Operated Door Stop**
- ⑥ **Grounded Metal Safety Barrier**
Prevents inadvertent contact with any live part, yet allows full-view inspection of the switch blade position.
- ⑦ **Door Interlock**
Prevents the door of the enclosure from being opened when the switch is closed.
- ⑧ **Switch Interlock**
Prevents inadvertent closure of the switch if the door of the enclosure is open.

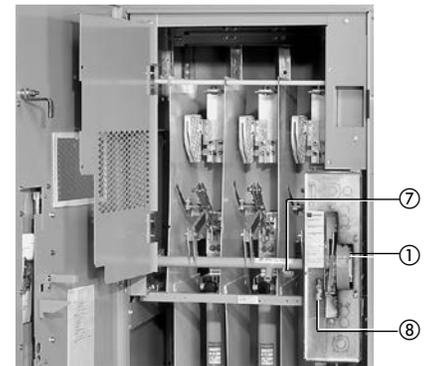

Switch with Hinged Screen Barrier Open

- ⑨ **High Quality Insulation**
Bus and switch insulators, switch drive rod barriers between phases, and barriers between outer phases and the housing, are of high strength, non-hygroscopic, track-resistant glass polyester as standard. Optional switch, fuse and main bus epoxy insulation system is available.
- ⑩ **Red-Green Switch Position Indicators**
- ⑪ **Provisions for Padlocking Switch Open or Closed**
- ⑫ **Provisions for Door and Switch Key Interlocks**
- ⑬ **The Operating Handle**
It is conveniently located behind a small access door giving the structure a smooth homogeneous appearance and discourages casual contact by unauthorized personnel.
- ⑭ **Switchgear Assembly Rating Nameplate**

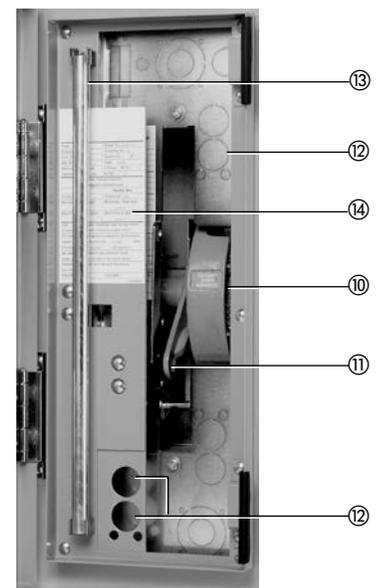

Switch Operating Compartment Door Open

Switch Technical Data

Test Data

Eaton's MVS switch ratings have been thoroughly tested in recognized high power laboratories with certified inspectors from both UL and CSA organizations. Tests were performed to substantiate all published ratings in accordance with ANSI, IEEE, CSA and NEMA standards.

The testing program included tests of:

- Basic impulse levels
- Momentary withstand
- Short-time withstand
- Fault closing
- Load interrupting at various loads, various power factors
- Mechanical life tests
- Temperature rise test

These tests verified not only the performance of the switch and integrated switch-fuse assembly, but also the suitability of the enclosure venting, rigidity and bus spacing.

The mechanical life test subjected the MVS switch to a number of no load cycles greater than the requirements tabulated in ANSI C37.22 standards. There were no moving or current carrying part failures as a result.

The Fault Close and Load Interrupting test demonstrated significant improved performance above ANSI/IEEE standards. See **Table 8.2-3** and **Table 8.2-4** for results.

Table 8.2-2. Switch Ratings (Non-Fused)

Rated Maximum Voltage	Impulse Withstand	Continuous and Load-Break	Fault-Close & Momentary Short-Circuit Current		Rated Short-Time Short-Circuit Current (2 sec.)
			kA Asym	kA Peak	
kV	kV	Amperes	kA Asym	kA Peak	kA rms Sym.
27	125	600	40	65	25
27	125	600	64	104	40

Table 8.2-3. MVS Switch Duty Cycle for Full Load Operations

Rated Maximum kV	Switch Load Interrupting Ampere Rating	ANSI Required Number of Load Interrupting Operations	Eaton MVS Switch Number of UL Tested Load Break Operations
27	600	10	10

Table 8.2-4. MVS Switch Duty Cycle for Fault Close Operations—Non-Fused

Rated Maximum kV	Switch Fault Close Rating		ANSI Required Number of Fault Close Operations	Eaton MVS Switch Number of UL Tested Fault Close Operations
	kA Asym	kA Peak		
27	40	65	1	1
27	61	99	1	1

Table 8.2-5. Primary Fuses, Standard Ratings and Fused Switch Fault Close Rating

Type Fuse	Switchgear Rated Maximum Voltage, kV	Fuse Rated Continuous Current Range, Amperes	Rated Interrupting Capacity kA Symmetrical ①	Fused Switch Momentary and Fault-Close Rating ①	
				kA Asym	kA Peak
RBA-200	25.8	10–200	10.5	16.8	27
RBA-400	25.8	0.5–300	21	33.6	54.6
RBA-800	25.8	0.5–540	21	33.6	54.6
Cooper NX	27	0.5–100	35	56	91

① When RBA expulsion fuses are used, and two ratings appear, the lower rating applies when the lower-rated switch (15 kV, 40 kA fault close, 25 kA short-time current) versus the higher rating that applies when the higher-rated switch (15 kV, 61 kA fault close, 38 kA short-time) is used.

Motor Operated MVS

Application

Eaton's MVS Pow-R-Drive™ motor operator makes possible the safety and convenience inherent in remote switch operation.



Motor Operated MVS Switch

Description

A MVS Pow-R-Drive motor operated switch is a standard, manually operated switch in combination with a heavy-duty electric motor-driven linear actuator that charges the spring. The linear actuator is located in a separate isolated low-voltage compartment. During electrical operation, it smoothly and quietly extends or retracts the proper distance to cause the switch mechanism to operate.

Standard motor operators are mounted in the switch enclosure. This eliminates the need for a separate motor compartment conserving floor space.



Manual Operation Override

Manual Operation

To operate manually, loosen the holding screw that keeps the pin connecting the linear actuator to the mechanism, and remove the pin. Remove the clevis pin on the support of the bottom of the linear actuator. Unplug the cord from the disconnecting terminal block as the actuator is removed and set the actuator aside. The switch can now be operated manually with the removable handle.

Lock Open Key Interlock

A keyed lock is standard to lock the switch in the open position only.

This lock not only locks the switch in the open position, but also breaks the electrical motor contacts integral to the motor control circuit and permits the key to be removed. With the key, the operator can then open the lock on the switch door. This scheme gives positive assurance that the switch is open and cannot be closed with the door open.

Metering

Electronic Metering and Communications Apparatus

MVS switchgear assemblies can be equipped with Eaton's family of Power Xpert and IQ digital meters to monitor a power circuit's electrical quantities within the capabilities of each device.

Eaton's power management products provide hardware and software solutions that allow customers to interface with their switchgear at varying levels of sophistication.

Power Xpert and IQ Meters monitor common electrical parameters and communicate the data via standard industry protocols and optional web interfaces. Power Xpert Gateways consolidate devices into a single web browser interface and provide Ethernet connectivity. Eaton's Foreseer web-based software system can display, analyze and store data from multiple devices across the facility to enable management of the customer's power system.

Outdoor Enclosures

Weatherproofing complying with the requirements of IEEE standard C37.20.3 is available for MVS switchgear assemblies. The weatherproofing consists of sloped roof panels that are joined together with caps. Doors and rear covers are fully gasketed. Externally accessible louvered filtered covers, top and bottom, front and rear, are provided for ventilation. At least one 250 watt heater is provided in each vertical section. Power for the heaters may be supplied from an external source, or an optional integral control power transformer may be specified to provide power for the heaters.



Electronic Metering



Outdoor Enclosure

Automatic Transfer Control



Two-Switch Automatic Transfer



ATC Controller

Application

Eaton's MVS switchgear with an automatic transfer control system is an integrated assembly of motor operated MVS switches, sensing devices and control components. Available in 27 kV class.

It is typically applied where the continuity of service for critical loads from two power sources in either a main/main or a main/tie/main configuration is desired.

MVS switchgear with an automatic transfer control system can meet most automatic throwover requirements as it has a wide variety of operational sequences embodied in one standard automatic transfer control system.

Please note that the duty cycle of load interrupter switches is limited by ANSI Standard C37.22. Refer to Table 8.2-3 for maximum number of switching operations allowed. If the number of switching operations is expected to exceed the maximum allowed, then load interrupter switches should not be used. Use circuit breakers (refer to Type MSB, MEB, MEF or VCP-W switchgear designs). Also note that the operating times of Eaton's motor operated load interrupter switches are much longer compared to circuit breakers, therefore, the switches are not suitable for closed-transition transfer applications. Use circuit breakers if closed-transition transfer is required.

Typical Two-Switch Automatic Transfer Using ATC Controller

Eaton's ATC-900 controller continuously monitors all three phases on both sources for correct voltages. Should the voltage of the normal source be lost while the voltage of the alternate source remains normal, the voltage sensing function in the ATC controller will change state starting the time delay function. If the voltage of the normal source is not restored by the end of the time delay interval, the normal switch will open and the alternate source switch will close, restoring power to the load.

ATC Controller

Eaton's ATC controller is equipped to display history information via the front panel. ATC-900 controller stores 320 time stamped events. Oscillographic data for last 10 events can be downloaded via the USB port or displayed in the controller's display window. The controller allows communications via RS-232 or Modbus through RS-485 port, Ethernet or via USB interface.

Standard Features

- Voltage sensing on both sources is provided by the ATC controller
- Lights to indicate status of switches, sources, etc.
- Interlocking to prevent paralleling of sources via software
- Control power for the automatic transfer control system is derived from the sensing voltage transformers
- Manual override operation
- Open transition on return to normal
- Programmable time delays on both sources, "OFF DELAY" and "ON DELAY"
- Four programmable digital inputs and outputs
- Single-source responsibility; all basic components are manufactured by Eaton
- Key interlocking of operating system and doors where required to provide operator safety

Optional Features

- Lockout on phase and/or ground overcurrents and/or internal bus faults
- Blown fuse overcurrent lockout
- Load current, power and PF metering with optional dcT module
- 24 Vdc control power input
- Up to four additional I/O modules, each with four programmable digital inputs and digital outputs

Surge Protection

IEEE standard C62.11 for **Metal Oxide Surge Arresters** lists the maximum rated ambient temperature as 40 °C. The ambient temperature inside an Eaton MVS switchgear vertical section may exceed this temperature, especially in outdoor applications where solar radiation may produce a significant contribution to the temperature.

Table 8.2-6 lists the recommended minimum duty cycle voltage rating for various system grounding methods. Surge arrester rating is based upon the ambient air temperature in the switchgear vertical section not exceeding 55 °C.

Table 8.2-6. Suggested Minimum Ratings (kV) for Metal Oxide Surge Arresters Located in Metal-Enclosed Switchgear

Service Voltage Line-to-Line kV	Distribution Class Arresters						Station Class Arresters					
	Solidly Grounded System		Low Resistance Grounded System		High Resistance or Ungrounded System		Solidly Grounded System		Low Resistance Grounded System		High Resistance or Ungrounded System	
	Arrester Ratings kV						Arrester Ratings kV					
	Nominal	MCOV	Nominal	MCOV	Nominal	MCOV	Nominal	MCOV	Nominal	MCOV	Nominal	MCOV
20.78	18	15.30	18	15.30	30	24.40	18	15.30	21	17.00	30	24.40
22.00	18	15.30	18	15.30	30	24.40	18	15.30	21	17.00	30	24.40
22.86	18	15.30	21	17.00	—	—	18	15.30	24	19.50	36	29.00
23.00	18	15.30	21	17.00	—	—	18	15.30	24	19.50	36	29.00
24.94	21	17.00	24	19.50	—	—	21	17.00	24	19.50	36	29.00
25.80	21	17.00	24	19.50	—	—	21	17.00	24	19.50	36	29.00
26.40	21	17.00	24	19.50	—	—	21	17.00	27	22.00	39	31.50
33.00	27	22.00	30	24.40	—	—	27	22.00	36	29.00	45	36.50
34.50	30	24.40	30	24.40	—	—	30	24.40	36	29.00	48	39.00
38.00	30	24.40	—	—	—	—	30	24.40	36	29.00	—	—

Note: MCOV = Maximum Continuous Operating Voltage.

System Options

Partial Discharge Sensing and Monitoring for Switchgear

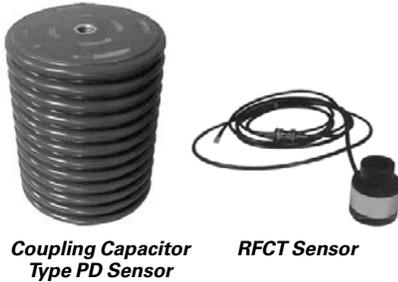

**Coupling Capacitor
Type PD Sensor**

RFCT Sensor



**InsulGard Relay
(PD Monitoring)**

Partial Discharge in Switchgear

Partial discharge (PD) is a common name for various forms of electrical discharges such as corona, surface tracking, and discharges internal to the insulation. It partially bridges the insulation between the conductors. These high frequency discharges are essentially small arcs occurring in or on the surface of the insulation system when voltage stress exceeds a critical value. With time, airborne particles, contaminants and humidity lead to conditions that result in partial discharges. Partial discharges start at a low level and increase as the insulation becomes deteriorated. Examples of partial discharge in switchgear are surface tracking across bus insulation, or discharges in the air gap between the bus and a support (such as where a bus passes through an insulating window between the sections of the switchgear). If partial discharge activity is not detected and corrected, it can develop into a full-scale insulation failure followed by an electrical fault. Most switchgear flashover and bus failures are a result of insulation degradation caused by various forms of partial discharges.

Sensing and Monitoring

Eaton's Type MVS metal-enclosed switchgear (2.4–27 kV) is corona-free by design. By making switchgear assemblies corona-free, Eaton has made its standard switchgear more reliable. However, as indicated above, with time, airborne particles, contaminants and humidity lead to conditions that cause partial discharges to develop in switchgear operating at voltages 4000V and above. Type MVS switchgear can be equipped with factory-installed partial discharge sensors and a partial discharge sensing relay for continuous monitoring under normal operation. Timely detection of insulation degradation through increasing partial discharges can identify potential problems so corrective action can be planned and implemented long before permanent deterioration develops. Partial discharge detection can be the foundation of an effective predictive maintenance program. Trending of partial discharge data over time allows prediction of failures, which can be corrected before catastrophic failure occurs.

The PD sensing and monitoring system consists of Eaton's InsulGard® relay and PD sensors, specifically developed for application in the switchgear to work with the relay. There are two types of PD sensors used in the switchgear: the first sensor is a coupling capacitor type sensor developed for use with 5 kV, 15 kV and 27 kV switchgear.

The coupling capacitor sensor detects partial discharges within the switchgear cubicle and/or adjacent cubicles, and is typically installed on the load side of the feeder switches or on the main bus. The second sensor is a small donut type radio frequency current transformer (RFCT). It is designed for installation around the ground shields of incoming or outgoing power cables. It detects partial discharges in power cables and monitors for external electrical noise.

Typically one set of coupling capacitor sensors is used at every two cubicles. One RFCT sensor is used for each incoming and outgoing power cable circuit.

Output signals from sensors (coupling capacitor and RFCT) are wired out to terminal blocks for future or field use, or connected to the InsulGard relay. One InsulGard relay can monitor up to 15 input signals, as well as temperature and humidity. The temperature and humidity sensors are included with each InsulGard relay system. The relay continuously monitors the switchgear primary system for partial discharges and provides an alarm signal (contact closure) when high PD level is detected. Also, data analysis and diagnostics by Eaton engineers can also be provided by remote communication with the InsulGard relay.

The sensors and InsulGard relay are optional in MVS switchgear.

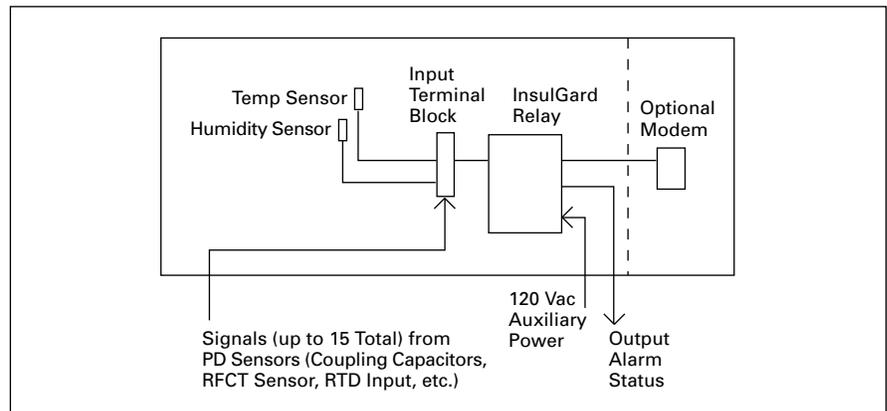

Figure 8.2-5. InsulGard Relay System

Partial Discharge Sensors and Monitoring for Switchgear

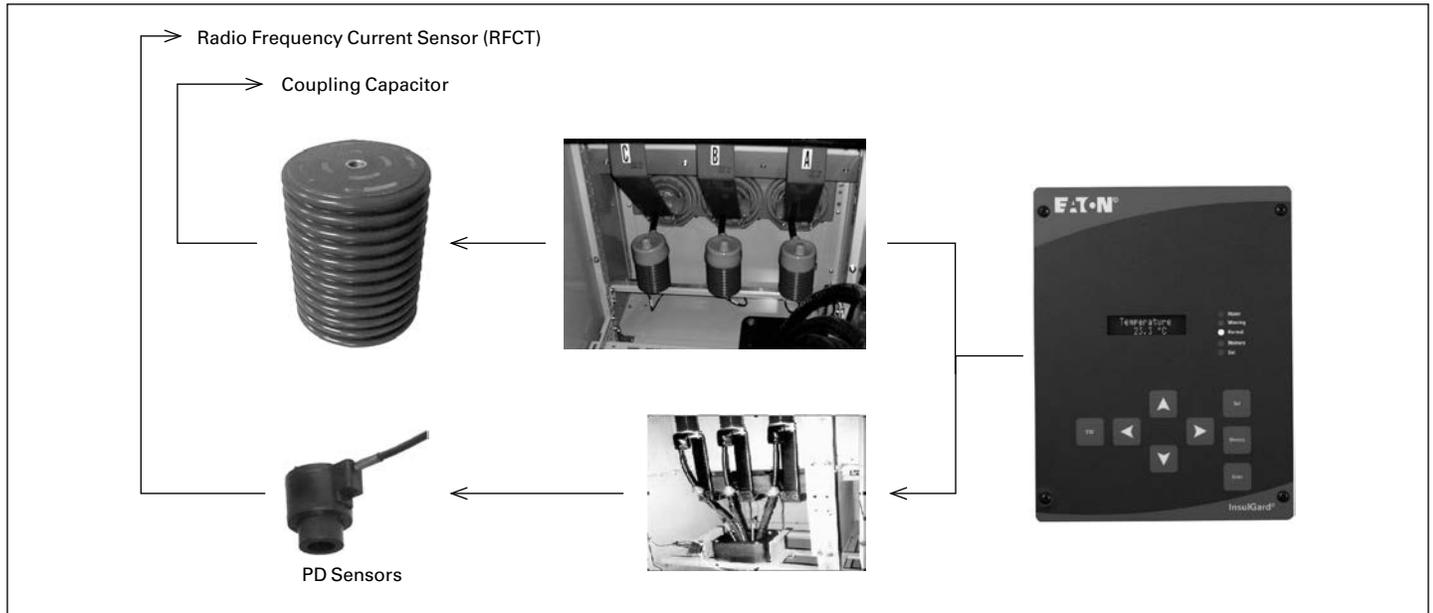

Figure 8.2-6. How the Process Works—Sensing and Data Collection

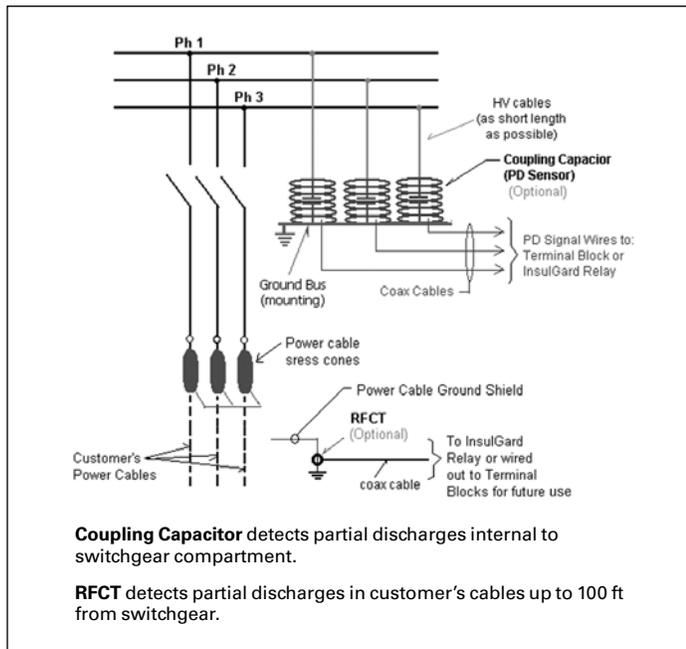

Figure 8.2-7. Typical Partial Discharge Sensor Connections in MVS Switchgear (5–27 kV)

Note: Use one set of PD sensing capacitors at every two vertical sections, or portion thereof. Use one RFCT at each incoming/outgoing cable circuit.

MVS Layouts

Typical Arrangements—27 kV

The drawings in this section represent the most common arrangements. **Layouts shown are for rear-accessible equipment. Front-accessible designs are available—refer to Eaton.** Many other configurations and combinations are available. Two voltage transformers for metering and one control transformer for auxiliary power can be mounted in the structures shown. For control power above 1 kVA, additional space is required.

Depth of units will vary due to cable entrance and exit requirements, the addition of lightning arresters, instrument transformers, special cable terminators, etc. Cables are shown out top and bottom for layout only. Top or bottom must be selected for incoming and for outgoing cables. Cable sizing is based on two 500 kcmil XLP or EPR insulated cables per phase using preformed slip-on cable termination devices.

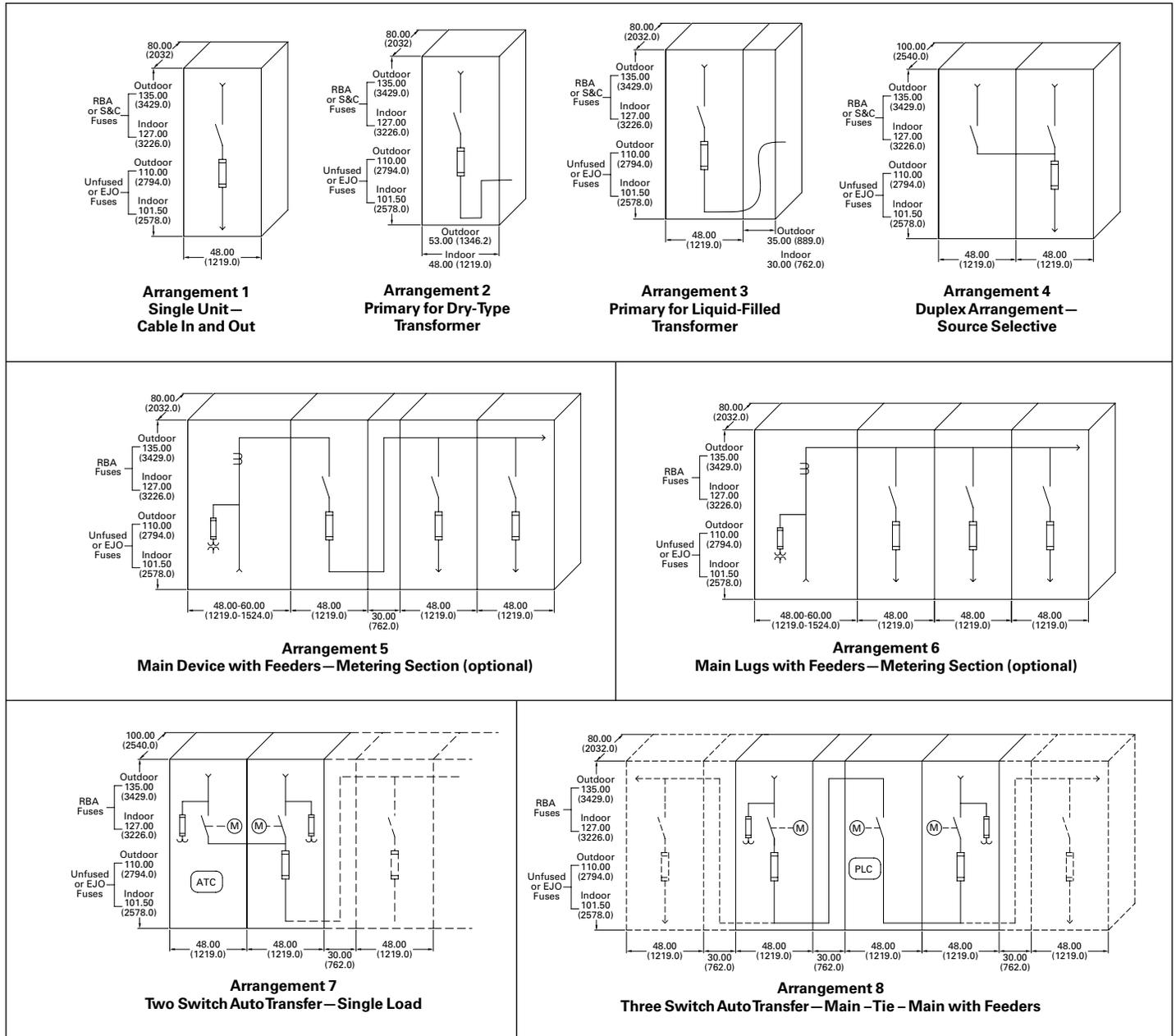

Figure 8.2-8. 27 kV Typical Arrangements—Dimensions in Inches (mm)

Note: Width for Utility Metering Structures may vary.

ATC = Automatic Transfer Controller (see **Page 8.2-9**)

M = Motor Operator

PLC = Programmable Logic Controller

Not to be used for construction purposes unless approved.

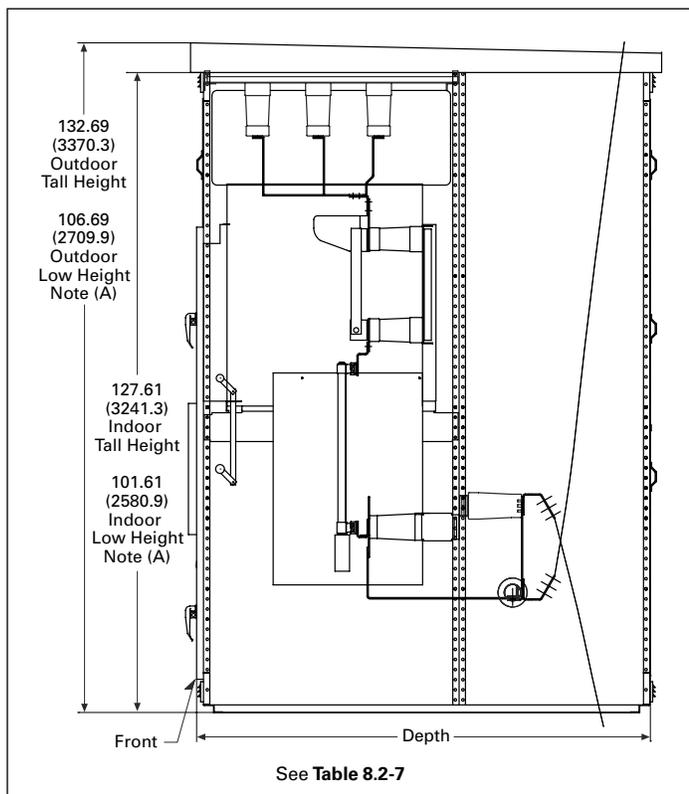

Figure 8.2-9. Rear Access, Cable Exit—Top or Bottom

Note: Low height dimensions are for non-fused, manually operated switch only. For all motor operated switches and all fused switches, tall height dimensions apply.

Table 8.2-7. Rear Access, Cable Exit—Top or Bottom

No. of Cables per Phase (Based on 500 kcmil)	Minimum Structure Depth— Inches (mm)
	27 kV
1 or 2	90.00 (2286.0)

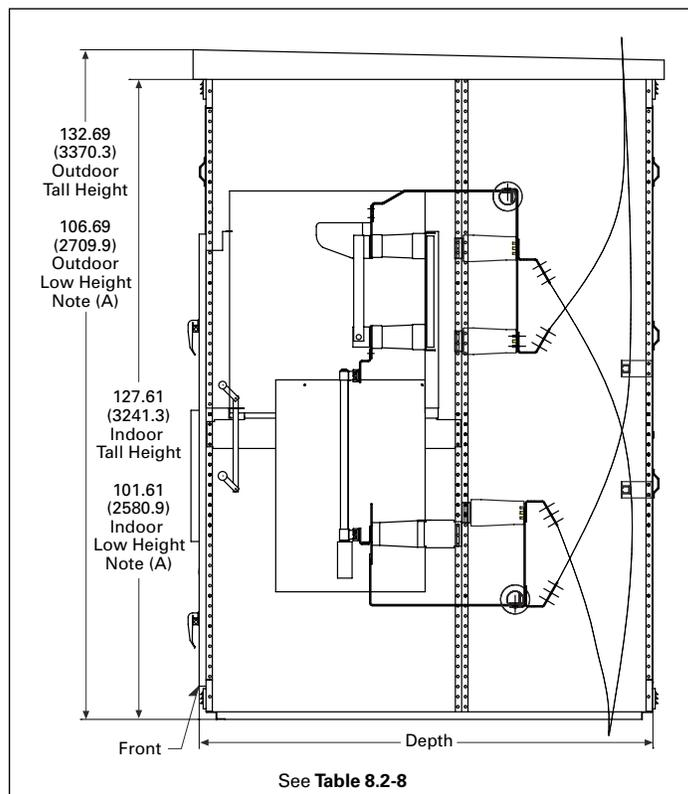

Figure 8.2-10. Rear Access, Cable Entry and Exit—Top or Bottom

Note: Low height dimensions are for non-fused, manually operated switch only. For all motor operated switches and all fused switches, tall height dimensions apply.

Table 8.2-8. Rear Access, Cable Entry and Exit—Top or Bottom

No. of Cables per Phase (Based on 500 kcmil)	Minimum Structure Depth— Inches (mm)
	27 kV
1 or 2	90.00 (2286.0)

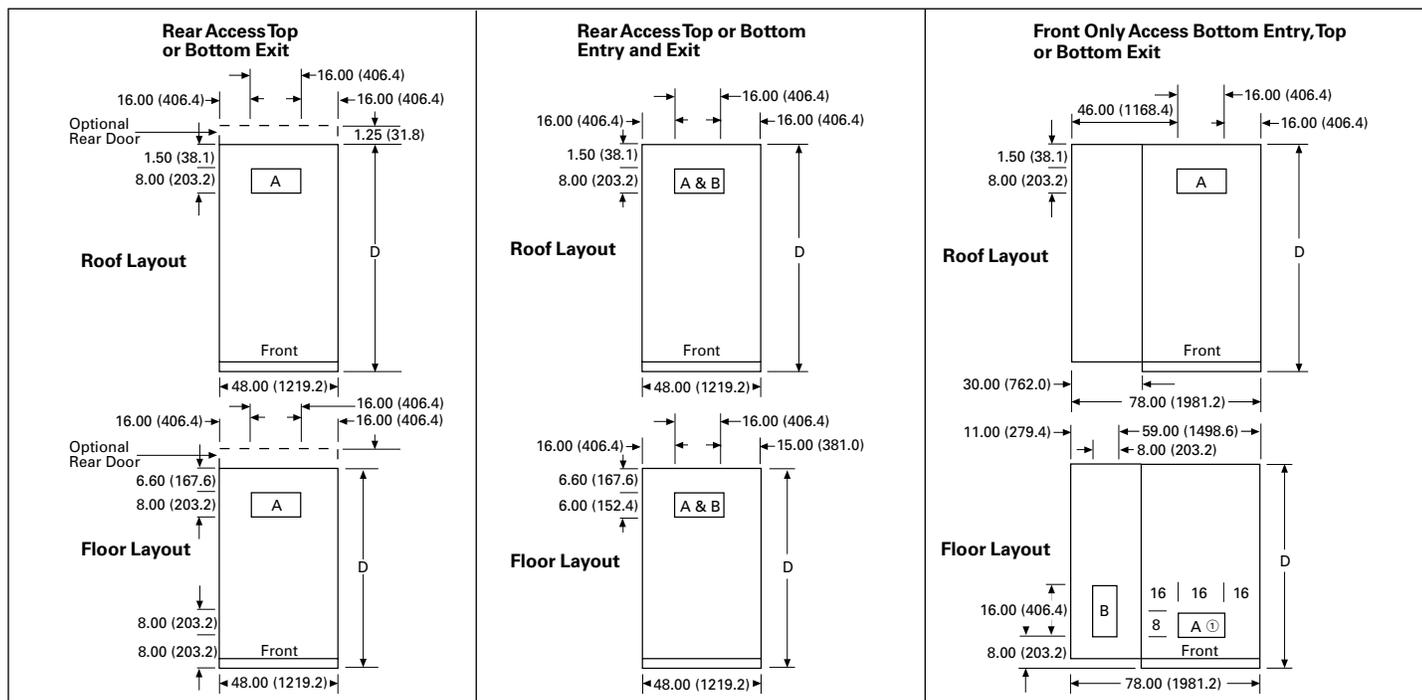

Figure 8.2-11. 27 kV Roof Layouts and Floor Layouts—Dimensions in Inches (mm)

① When high continuous current fusing or instrumentation is required, consult the Eaton factory for guidance.

Note: A = Power Cable to Load. B = Power Cable from Source. See **Figure 8.2-8**, **Figure 8.2-9** and **Figure 8.2-10** as applicable for dimension D on **Page 8.2-13** and **Page 8.2-14**.

Not to be used for construction purposes unless approved.

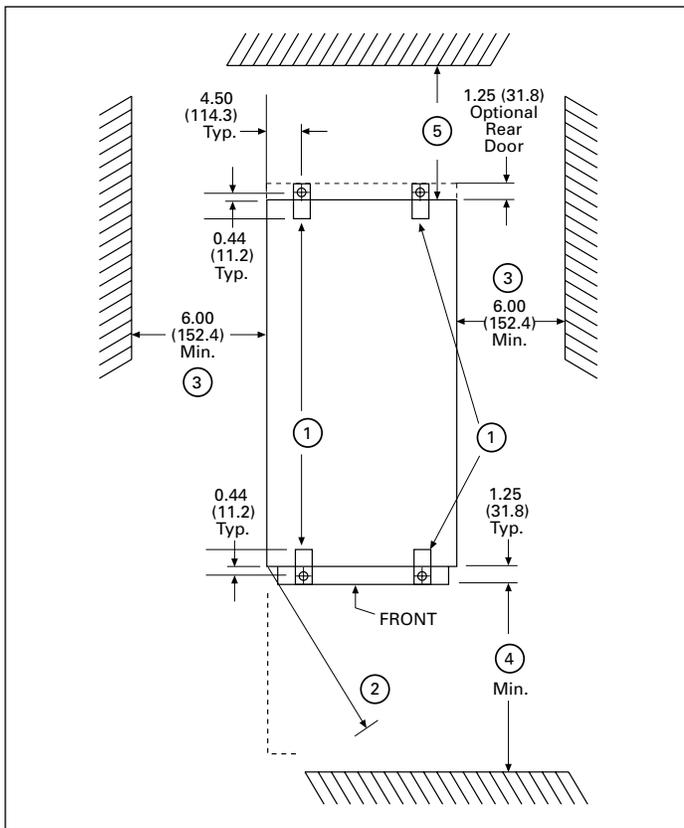

Figure 8.2-12. Typical Anchor Plan—27 kV Outdoor

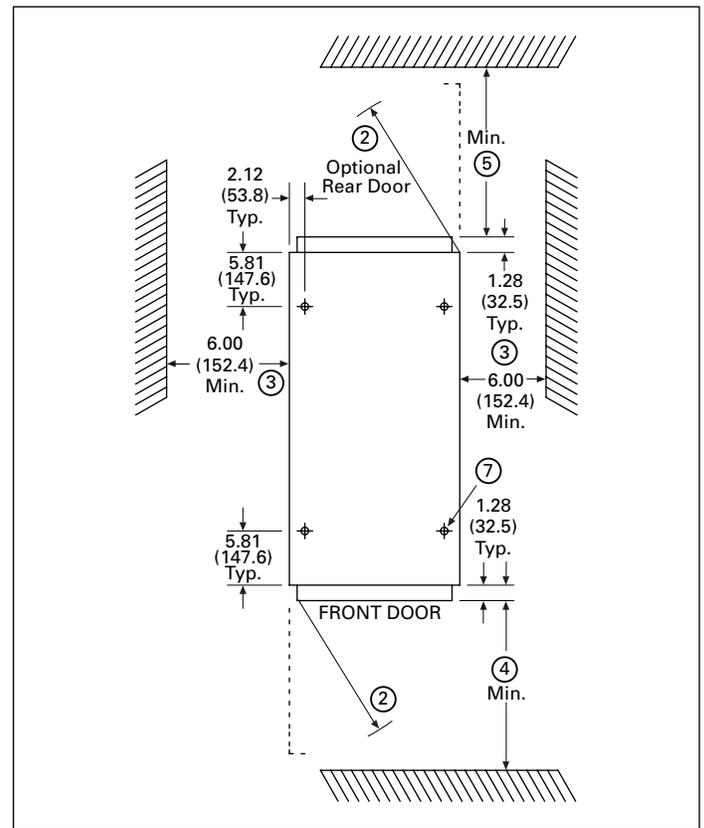

Figure 8.2-13. Typical Anchor Plan—27 kV Indoor

- ① Typical location for four (two front, two back) Eaton supplied tie down clips for all 27 kV. Customer provided bolts for anchoring should be 0.50–13 min. SAE Grade 5 M 12 x 1.75 min. CL 10.9 or stronger, and tightened to 75 ft-lb.
- ② Door swing equals vertical section width at 90°.
- ③ Minimum clearance on side. Local jurisdictions may require a larger clearance.
- ④ Minimum clearance in front is the width of the widest vertical section plus 1.00 inch (25.4 mm), but not less than that required by the NEC . Local jurisdictions may require a larger distance.
- ⑤ Minimum clearance in rear is 30.00 inches (762.0 mm). If rear doors are supplied, the minimum clearance is the width of the widest vertical section equipped with a rear door plus 1.00 inch (25.4 mm). Local jurisdictions may require a larger clearance.
- ⑥ Finished foundation's surface shall be level within 0.06-inch (1.5 mm) in 36.00 inches (914.4 mm) left-to-right, front-to-back and diagonally, as measured by a laser level.
- ⑦ Locations for 0.50-inch (12.7 mm) anchor bolts.

Weights

Table 8.2-9. Approximate Weights in Lb (kg)

Switch Description	Indoor	Outdoor
27 kV Class		
Non-fused switch	2000 (908)	2400 (1090)
Fuses (3), add	300 (136)	300 (136)
Indoor transition	1100 (499)	—
Outdoor throat	—	1200 (545)
Motor operator adder	400 (182)	400 (182)

Eaton
1000 Eaton Boulevard
Cleveland, OH 44122
United States
Eaton.com

© 2019 Eaton
All Rights Reserved
Printed in USA
Publication No. CA022010EN / Z22791
May 2019