

Medium-voltage power distribution and control systems > Switchgear >

VacClad-W 26" wide, metal-clad medium-voltage drawout vacuum breakers

Contents

General Description	5.2-2
Usual and Unusual Service Conditions	5.2-3
Devices	5.2-4
Circuit Breakers	5.2-4
Protective Relays and Metering	5.2-5
Instrument Transformers	5.2-5
Integral Motorized Remote Racking Option (VC-W MR2)	5.2-7
Accessories	5.2-10
System Options	5.2-11
Layouts and Dimensions	5.2-14
Standard Layouts	5.2-14
Application Data	5.2-18
Weights	5.2-18
Control Power	5.2-18
Operations	5.2-19
Heat Loss	5.2-19
Typical Schematics	5.2-20

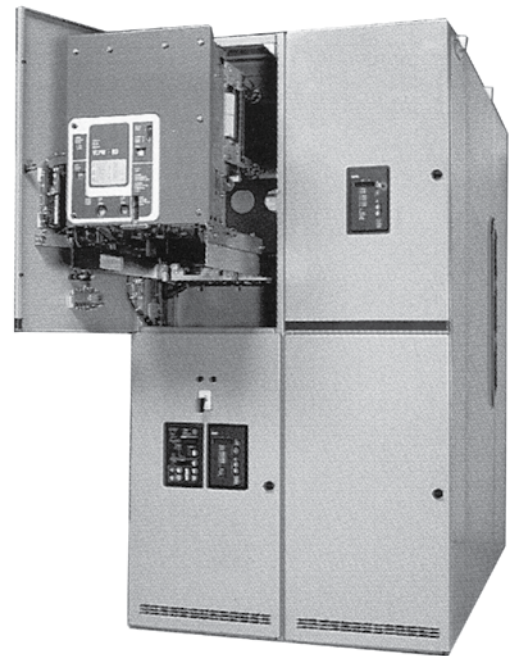

EATON

Powering Business Worldwide

General Description

26.00-Inch (660.4 mm) Wide 5 kV 250 MVA Switchgear

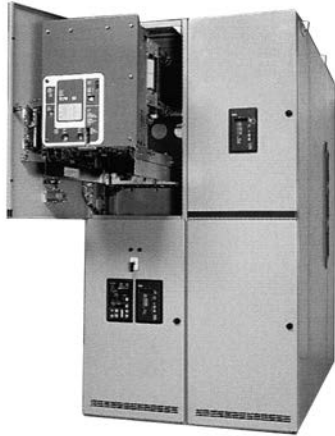

Fully Withdrawn Breaker

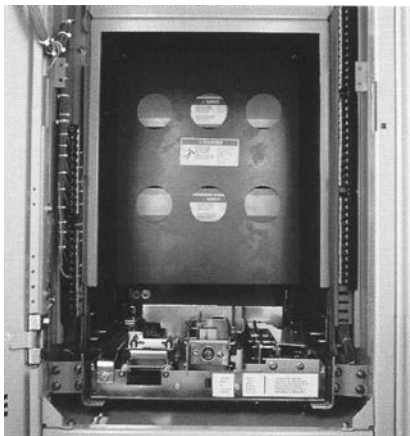

Automatic Shutters

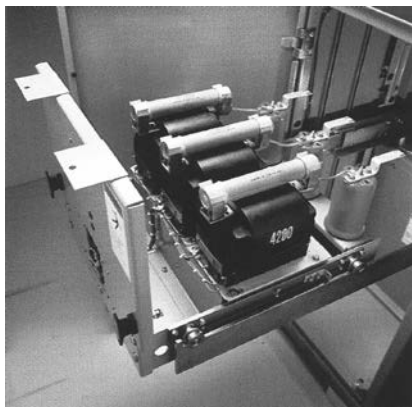

Fused PT Drawer

Application Description

This narrow width VacClad-W MV Metal-Clad switchgear was designed for use in instances where floor space requirements would not allow the industry standard 36.00-inch (914.4 mm) wide switchgear. Typical applications include not only new construction but also replacement switchgear for installations previously equipped with 26.00-inch (660.4 mm) wide air-break devices. This line of switchgear has also been used where 5 kV, 1200 A, 250 MVA applications are commonplace, such as generator and control applications.

Ratings

The 26.00-inch (660.4 mm) wide switchgear line is designed for use with Eaton's Type VCPW-ND "Narrow Design" vacuum circuit breakers rated 4.76 kV, 60 kV BIL, 250 MVA, 1200 A maximum, with rated main bus of 1200 or 2000 A. For installations requiring 2000 A main breakers with 1200 A feeders, lineups can be built with standard 36.00-inch (914.4 mm) wide main breaker cubicles and 26.00-inch (660.4 mm) wide feeders.

Configurations

26.00-Inch (660.4 mm) Wide Standard Model

The 26.00-inch (660.4 mm) wide design is flexible. Available configurations include breaker over breaker, one or two auxiliary drawers over breaker, breaker over one or two auxiliary drawers, or up to four auxiliary drawers in one vertical section. The standard height and depth are 95.00-inch (2413.0 mm) and 96.25-inch (2444.8 mm) respectively. A breaker over auxiliary, or auxiliary over breaker combination can be supplied in reduced depth of 86.25-inch (2190.8 mm). The depth of breaker over breaker combination can also be reduced to 86.25-inch (2190.8 mm) if power cables for top breaker enter from the top and the cables for bottom breaker enter from the bottom.

The main bus location and connections in the standard 95.00-inch (2413.0 mm) high 26.00-inch (660.4 mm) wide design are 100% compatible with standard 95.00-inch (2413.0 mm) high 36.00-inch (914.4 mm) wide vertical sections. As a result, additions to existing Eaton 5 kV, 250 MVA 36.00-inch (914.4 mm) wide VCP-W installations can be simply and rapidly performed without costly system modifications and transition sections. Refer to **Page 5.2-14** through **Page 5.2-18** for available configurations, dimensions and weights.

26.00-Inch (660.4 mm) Wide Low Profile Model

In addition to the floor space saving offered by the standard 26.00-inch (660.4 mm) wide model, a further saving in the height and depth of the switchgear is also available. Where height and depths are an issue, such as an outdoor powerhouse or in a mobile power container, the standard 95.00-inch (2413.0 mm) high unit can be reduced to an 80.00-inch high (2032.0 mm), 72.00-inch (1828.9 mm) deep low profile model. Main bus rating available in the 80.00-inch (2032.0 mm) high x 72.00-inch (1828.9 mm) deep low profile model is limited to 1200 A maximum. It is not compatible in size or location with standard 26.00-inch (660.4 mm) wide or 36.00-inch (914.4 mm) wide, 95.00-inch (2413.0 mm) high VCP-W units.

The low profile model is designed to house breaker over auxiliary or auxiliary over breaker, or auxiliary over auxiliary. In order to provide maximum vertical space for power cable terminations, auxiliary over breaker configuration should be used for customer's top entrance cables, and breaker over auxiliary configuration should be used for customer's bottom entrance cables. Auxiliary compartments are designed to accommodate one or two auxiliary drawers. That is, up to four auxiliary drawers can be installed in an auxiliary over auxiliary configuration. A set of two line-to-line or three line-to-ground connected voltage transformers, or a single-phase control power transformer up to 15 kVA can be installed in each auxiliary drawer. Because of the reduced depth, control devices cannot be located on breaker compartment door. All control devices should be located on the auxiliary compartment doors. Refer to **Page 5.2-14** through **Page 5.2-18** for available configurations, dimensions and weights.

For all 26.00-inch (660.4 mm) wide configurations, multifunction microprocessor-based relays and meters, such as Eaton's E-Series relays and Power Xpert® meters are recommended for reduced panel space.

Usual and Unusual Service Conditions

Usual Service Conditions

Usual service conditions for operation of metal-clad switchgear are as follows:

- Altitude does not exceed 3300 feet (1000 m)
- Ambient temperature within the limits of -30 °C and +40 °C (-22 °F and +104 °F)
- The effect of solar radiation is not significant

Applications Above 3300 Feet (1006 m)

Equipment utilizing sealed interrupting devices (such as vacuum interrupters) does not require derating of rated maximum voltage. The rated one-minute power frequency withstand voltage, the impulse withstand voltage and the continuous current rating must be multiplied by the appropriate correction factor in **Table 5.2-3** to obtain modified ratings that must equal or exceed the application requirements.

Note: Intermediate values may be obtained by interpolation.

Applications Above or Below 40 °C Ambient

Refer to ANSI C37.20.2, Section 8.4 for load current-carrying capabilities under various conditions of ambient temperature and load.

Applications at Frequencies Less Than 60 Hz

Rated Short-Circuit Current

Based on series of actual tests performed on Type VCP-W circuit breakers and analysis of these test data and physics of vacuum interrupters, it has been found that the current interruption limit for Type VCP-W circuit breakers is proportional to the square root of the frequency. **Table 5.2-1** provides derating factors, which must be applied to breaker interrupting current at various frequencies.

Table 5.2-1. Derating Factors

Interrupting Current Derating Factors			
50 Hz	25 Hz	16 Hz	12 Hz
None	0.65	0.52	0.45

Rated Short-Time and Close and Latch Currents

No derating is required for short time and close and latch current at lower frequency.

Rated Continuous Current

Because the effective resistance of circuit conductors is less at lower frequency, continuous current through the circuit can be increased somewhat. **Table 5.2-2** provides nominal current rating for VCP-W breakers when operated at frequencies below 60 Hz.

Table 5.2-2. Current Ratings

Rated Continuous Current at 60 Hz	Nominal Current at Frequency Below 60 Hz			
	50 Hz	25 Hz	16 Hz	12 Hz
1200 A	1243	1410	1519	1589
2000 A	2075	2374	2573	2703
3000 A	3119	3597	3923	4139

Power Frequency and Impulse Withstand Voltage Ratings

No derating is required for lower frequency.

CTs, VTs, Relays and Instruments

Application at frequency other than rated frequency must be verified for each device on an individual basis.

Table 5.2-3. Altitude Derating Factors

Altitude Above Sea Level in Feet (m)	Altitude Correction Factor to be Applied to:	
	Voltage	Rated Continuous Current
3300 (1006) (and Below)	1.0	1.0
4000 (1219)	0.98	0.995
5000 (1524)	0.95	0.991
6000 (1829)	0.92	0.987
6600 (2012)	0.91	0.985
7000 (2137)	0.89	0.98
8000 (2438)	0.86	0.97
9000 (2743)	0.83	0.965
10,000 (3048)	0.80	0.96
12,000 (3658)	0.75	0.95
13,200 (4023)	0.72	0.94
14,000 (4267)	0.70	0.935
16,000 (4877)	0.65	0.925
16,400 (5000)	0.64	0.92
18,000 (5486)	0.61	0.91
20,000 (6096)	0.56	0.90

Unusual Service Conditions

Applications of metal-clad switchgear at other than usual altitude or temperature, or where solar radiation is significant, require special consideration. Other unusual service conditions that may affect design and application include:

- Exposure to salt air, hot or humid climate, excessive dust, dripping water, falling dirt, or other similar conditions
- Unusual transportation or storage conditions
- Switchgear assemblies when used as the service disconnecting means
- Installations accessible to the general public
- Exposure to seismic shock
- Exposure to nuclear radiation

Circuit Breakers

Table 5.2-4. Available 5/15 kV VCP-W Vacuum Circuit Breaker Types Rated on Symmetrical Current Rating Basis, Per ANSI Standards (Rated K > 1) ①②③

Identification		Rated Values											Related Required Capabilities							
Circuit Breaker Type	Nominal Voltage Class	Nominal 3-Phase MVA Class	Voltage		Insulation Level		Current		Rated Transient Recovery Voltage			Rated Interrupting Time	Rated Permissible Tripping Delay	Rated Reclosing Time	Rated Maximum Voltage Divided by K	Current Values				Asymmetry Factor for VCP-W Breakers
			Rated Maximum Voltage	Rated Voltage Range Factor	Power Frequency Withstand Voltage (1 min.)	Lightning Impulse Withstand Voltage (1.2 x 50 μs)	Rated Continuous Current at 60 Hz	Rated Short-Circuit Current (at Rated Maximum kV)	Rated Crest Voltage	Rated Time to Crest	Rate of Rise of Recovery Voltage ⑤					Maximum Sym. Interrupting Capability	3-Second Short-Time Current Carrying Capability	Closing and Latching Capability (Momentary)		
kV Class	MVA Class	V kV rms	K ④	kV rms	kV Crest	Amp	I ① kA rms	E2 kV Crest	T2 μS	kV/μS	Cycles	Y ⑥ Sec.	⑦ ms	V/K kV rms	KI kA rms	KI kA rms	2.7 KI kA Crest	1.6 KI ⑧ kA rms asym.	⑨ S	
50 VCP-WND 250	4.16	250	4.76	1.24	19	60	1200	29	8.9	50	0.2	5	2	300	3.85	36	36	97	58	1.2

① 5 and 15 kV circuit breakers are UL listed.

② Circuit breakers shown in this table were tested in accordance with IEEE standard C37.09-1979.

③ Contact Eaton for availability of these circuit breakers.

④ For three-phase and line-to-line faults, the symmetrical interrupting capability at an operating voltage

$$I_{sc} = \frac{V}{V_o} \text{ (Rated Short-Circuit Current)}$$

But not to exceed KI.

Single line-to-ground fault capability at an operating voltage

$$I_{sc} = 1.15 \frac{V}{V_o} \text{ (Rated Short-Circuit Current)}$$

But not to exceed KI.

The above apply on predominately inductive or resistive three-phase circuits with normal-frequency line-to-line recovery voltage equal to the operating voltage.

$$\text{⑤ } RRRV = 1.137 \frac{E_2}{T_2}$$

⑥ Tripping may be delayed beyond the rated permissible tripping delay at lower values of current in accordance with the following formula:

$$T \text{ (seconds)} = Y \left(\frac{\text{(K Times Rated Short-Circuit Current)}}{\text{Short-Circuit Current Through Breaker}} \right)^2$$

The aggregate tripping delay on all operations within any 30-minute period must not exceed the time obtained from the above formula.

⑦ For reclosing service, there is **No derating** necessary for Eaton's VCP-W family of circuit breakers. **R = 100%**. Type VCP-W breaker can perform the O-C-O per ANSI C37.09; O-0.3s-CO-15s-CO per IEC 56; and some VCP-Ws have performed O-0.3s-CO-15s-CO-15s-CO-15s-CO; **all with no derating**. Contact Eaton for special reclosing requirements.

⑧ Included for reference only.

⑨ Asymmetrical interrupting capability = "S" times symmetrical interrupting capability, both at specified operating voltage.

Protective Relays and Metering

Protective Relays

A full scope of protective relays designed to meet all application requirements is available to provide the utmost in system and component protection.

Integrated Monitoring Protection and Control

Communications System

Eaton's power management products provide hardware and software solutions that allow customers to interface with their switchgear at varying levels of sophistication. Power Xpert and IQ Meters monitor common electrical parameters and communicate the data via standard industry protocols and optional Web interfaces. Power Xpert Gateways consolidate devices into a single Web browser interface and provide Ethernet connectivity. Eaton's Power Xpert Insight® and Foreseer Web-based software systems display, analyze and store data from multiple devices across the facility to enable management of the customer's power system.

Instrument Transformers

Instrument transformers are used to protect personnel and secondary devices from high voltage, and permit use of reasonable insulation levels for relays, meters and instruments. The secondaries of standard instrument transformers are rated at 5 A and/or 120V, 60 Hz.

Voltage Transformers

Selection of the ratio for voltage transformers is seldom a question since the primary rating should be equal to or higher than the system line-to-line voltage. The number of potential transformers per set and their connection is determined by the type of system and the relaying and metering required.

When two VTs are used, they are typically connected L-L, and provide phase-to-phase voltages, (Vab, Vbc, Vca) for metering and relaying.

When three VTs are used, they are connected line-to-ground, and provide phase-to-phase (Vab, Vbc, Vca), as well as phase-to-ground (Va, Vb, Vc) voltages for metering and relaying.

If metering or relaying application requires phase-to-ground voltages, use three VTs, each connected L-G. If not, use of two VTs connected L-L is sufficient.

For ground detection, three VTs connected in Line-to-ground/broken-delta are used.

A single VT, when used, can be connected line-to-line (it will provide line-to-line output, for example Vab or Vbc or Vca), or line-to-ground (it will provide line-to-ground output, for example Va or Vb or Vc). Generally, a single VT is used to derive voltage signal for synchronizing or Over Voltage/Under Voltage function.

Current Transformers

The current transformer ratio is generally selected so that the maximum load current will read about 70% full scale on a standard 5 A coil ammeter. Therefore, the current transformer primary rating should be 140–150% of the maximum load current.

Maximum system fault current can sometimes influence the current transformer ratio selection because the connected secondary devices have published one-second ratings.

The zero-sequence current transformer is used for sensitive ground fault relaying or self-balancing primary current type machine differential protection. The zero-sequence current transformer is available with a nominal ratio of 50/5 or 100/5 and available opening size for power cables of 7.25 inches (184.2 mm). Special zero-sequence transformers with larger windows are also available.

The minimum number of current transformers for circuit relaying and instruments is three current transformers, one for each phase or two-phase connected current transformers and one zero-sequence current transformer. Separate sets of current transformers are required for differential relays.

The minimum pickup of a ground relay in the residual of three-phase connected current transformers is primarily determined by the current transformer ratio. The relay pickup can be reduced by adding one residual connected auxiliary current transformer. This connection is very desirable on main incoming and tie circuits of low resistance grounded circuits.

Standard accuracy current transformers are normally more than adequate for most standard applications of microprocessor-based protective relays and meters. See **Table 5.2-7** for CT accuracy information.

Table 5.2-5. Standard Voltage Transformer Ratio Information

Rating-Volts	2400	4200	4800	7200	8400	10800	12000	14400	15600	18000	21000	24000	27000	36000
Ratio	20-1	35-1	40-1	60-1	70-1	90-1	100-1	120-1	130-1	150-1	175-1	200-1	225-1	300-1

Table 5.2-6. Standard Voltage Transformer, 60 Hz Accuracy Information

Switchgear		Voltage Transformer—ANSI Accuracy											
kV Class	kV BIL	Maximum Number Per Set and Connection	Standard Ratios	Burdens at 120 Volts				Burdens at 69.3 Volts				Thermal Rating 55°C Connection	Volt-Ampere
				W, X, Y	Z	M	ZZ	W, X	Y	M	Z		
5	60	2LL or 3LG	20 ① 35 40	0.3	1.2	—	—	0.3	—	—	—	LL LG LG ②	700 400 700

① For solidly grounded 4160 V system only or any type 2400 V system.

② For solidly grounded system only.

Note: LL = Line-to-line connection. LG = Line-to-ground connection.

Table 5.2-7. Current Transformers, 55 °C Ambient

CT Ratio (MR = Multi-Ratio)	Metering Accuracy Classification			Relaying Accuracy Classification		
	At 60 Hz Standard Burden B 0.1	At 60 Hz Standard Burden B 0.5	At 60 Hz Standard Burden B 1.8	Minimum Accuracy Required per IEEE C37.20.2	Standard Accuracy Supplied in VCP-W Switchgear	Optional High Accuracy Available in VCP-W Switchgear
50:5 75:5 100:5	1.2 1.2 1.2	— 2.4 2.4	— — —	C10 C10 C10	— C10 C10	C10 C20 C20
150:5 200:5 250:5	0.6 0.6 0.6	2.4 2.4 2.4	— — —	C20 C20 ③	C20 C20 C20	C50 C50 C50
300:5 400:5 500:5	0.6 0.3 0.3	2.4 1.2 0.3	2.4 2.4 2.4	C20 C50 ③	C20 C50 C50	C100 C100 C100
600:5 800:5 1000:5	0.3 0.3 0.3	0.3 0.3 0.3	2.4 1.2 0.3	C50 C50 ③	C100 C100 C100	C200 C200 C200
1200:5 1500:5 2000:5	0.3 0.3 0.3	0.3 0.3 0.3	0.3 0.3 0.3	C100 C100 C100	C200 C200 C200	C400 C400 C400
2500:5 3000:5 4000:5	0.3 0.3 0.3	0.3 0.3 0.3	0.3 0.3 0.3	③ C100 C100	C200 C200 C200	C400 C400 C400
600:5 MR 1200:5 MR 2000:5 MR 3000:5 MR	0.3 0.3 0.3 0.3	0.3 0.3 0.3 0.3	2.4 0.3 0.3 0.3	③ ③ ③ ③	C100 C200 C200 C200	C200 C400 C400 C400
50:5 zero sequence 100:5 zero sequence	— —	— —	— —	— —	C10 C20	— —

③ Not listed in C37.20.2.

Note: Maximum number of CTs— Two sets of standard accuracy or one set of high accuracy CTs can be installed in the breaker compartment on each side of the circuit breaker.

Integral Motorized Remote Racking Option (VC-W MR2)

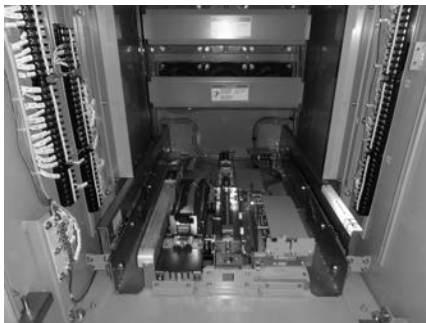

Breaker Levering Pan Assembly with Test Position – VC-W MR2 Integral Racking Device

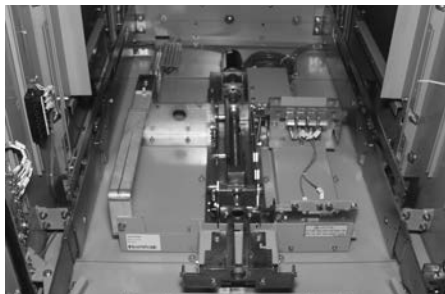

Type VC-W Arc-Resistant Switchgear Auxiliary Drawer with Type MR2 Integral Racking



Type VC-W Standard Switchgear Auxiliary Drawer with Type MR2 Integral Racking



MR2 Hand-Held Pendant

VC-W MR2 is an optional motorized racking device accessory installed inside a circuit breaker or auxiliary compartment. It is available for application in circuit breaker compartments of 5/15/27/38 kV Type VC-W arc and non-arc, and 5 kV VC-W ND metal-clad switchgear. It is also available for application in auxiliary compartments of 5/15 kV Type VC-W arc-resistant and standard switchgear. This optional accessory allows a user to safely move a circuit breaker between Connected, Test and Disconnected positions and auxiliary drawer (VT, CPT, primary fuse) between Connected and Disconnected positions within their respective compartments from a safe distance away from the switchgear. The MR2 controller also allows a user to electrically open and close the circuit breaker from a safe distance away from the switchgear. For switchgear designs/ratings not included above, contact Eaton for availability of MR2 accessory.

A microprocessor-based controller card, located below the drive motor, interfaces with an external hand-held pendant (standard), discrete external I/O (optional) or external Modbus communication (optional) and controls the breaker/auxiliary drawer movement via the drive motor. The system is also designed such that it allows manual racking of the breaker/auxiliary using the levering crank accessory if needed. The VC-W MR2 controller interface is shown in **Figure 5.2-1**. The crank safety switch disables the motor whenever a breaker/auxiliary is being manually racked in or out. The connect, test and disconnect limit switches provide breaker/auxiliary position inputs to the controller card. In addition to the standard permissive switch, two terminals are provided for connection of the customer's external interlocking/permissive contact(s). Note that a single-phase 120 Vac control supply is required for proper operation of the VC-W MR2 controller and the drive motor.

When VC-W MR2 integral racking is supplied, its controller card is wired to the CAT 6 jack installed in the associated breaker/auxiliary compartment door, and each switchgear lineup is shipped with one hand-held pendant with 30 feet of CAT 6 cable (lengths up to 100 ft available). The pendant interfaces with the MR2 controller card via the CAT 6 cable through a CAT 6 jack located on the breaker/auxiliary compartment door. It allows the operator to move away from the switchgear up to 30 feet. The pendant includes Enable pushbutton for additional security. It must be pressed in order to activate the pendant functions. By pressing Enable pushbutton and an appropriate function pushbutton together momentarily, the operator can rack the breaker between Connected, Test and Disconnected positions or open or close the breaker or rack the auxiliary drawer between Connected and Disconnected positions. Breaker or auxiliary drawer positions (Connect, Test, Disconnect) and breaker opened/closed status are indicated by appropriate LED lights on the pendant. A blinking light indicates that the breaker/auxiliary is in motion through the selected position.

A solid (non-blinking) light indicates that the breaker/auxiliary has reached and stopped in the selected position. In case normal operation fails, the appropriate error code is displayed in a separate two-character LED display window on the pendant. A list of various error codes and their descriptions along with suggested corrective actions are printed on the back side of the pendant. Examples of error states: motor overcurrent, motor overtemperature, motor timed out, breaker position unknown, open permissive, communication error and no breaker/auxiliary.

In addition to pendant, three optional I/O interfaces can be supplied as follows:

1. I/O interface to allow racking of breaker (connect, test, disconnect) or auxiliary drawer (connect, disconnect) by external hardwired dry contacts and 24 Vdc output for corresponding remote position indicating LEDs.
2. I/O board that provided dry contacts for remote indication of breaker (connect, intermediate, test, disconnect)/auxiliary drawer (connect, test) position within its compartment.
3. I/O interface to allow breaker open/close functions via external hardwired dry contacts and 24 Vdc output for corresponding remote open/close status LEDs.

The remote LED lights are not included with MR2. If the customer needs to operate the MR2 with the hand-held pendant, the pendant becomes the master and will override the customer's remote control signals.

The VC-W MR2 controller is also equipped with terminal blocks to allow the customer to interface with the controller via their SCADA system using a Modbus interface. Please note that only one of the two options, discrete I/O interface or Modbus interface, can be used, but not both. **Figure 5.2-2** shows an illustration of a typical Modbus control example. Additional components shown outside the MR2 controller in **Figure 5.2-2** are not included with the MR2. System-level controls can be optionally supplied by Eaton's Engineering Services & Systems. If the customer needs to operate the MR2 with the hand-held pendant, the pendant becomes the master and will override the Modbus interface. Error codes are displayed on Modbus devices when controlling the MR2 with Modbus and on the pendant when controlling with the pendant.

Technical Data

Control Supply Ratings

- Nominal control voltage— 120 Vac, 50 or 60 Hz, single-phase
- Control voltage range— 100 to 140 Vac, 50 or 60 Hz
- Time to travel from connect to disconnect, or disconnect to connect— 50 seconds maximum
- Current draw during the travel— 15 A maximum for about 3 seconds and 3.6 A for about 24 seconds
- Optional dry output contacts when included for position indications are rated for 125 Vac, 2 A
- External permissive contacts, when used, must be rated for 24 Vdc, 50 mA

Requirements for External Contacts and LEDs when Interfacing with MR2

- External contacts should be rated for minimum open circuit voltage of 24 Vdc, and be able to close and carry 5 mA at 24 Vdc
- When remote LEDs are used, use 24 Vdc rated LEDs, current up to 20 mA
- Optional dry output contacts when included for position indications are rated for 125 Vac, 2 A
- External permissive contacts, when used, must be rated for 24 Vdc, 50 mA

It is the customer's responsibility to provide single-phase 120 V, 50 or 60 Hz nominal supply for the MR2 controller. It can be derived from within the switchgear if an appropriate control power transformer is available within the switchgear.

Type VC-W MR2 motorized racking accessory has been endurance tested and guaranteed for 500 operations as required by IEEE C37.20.2.

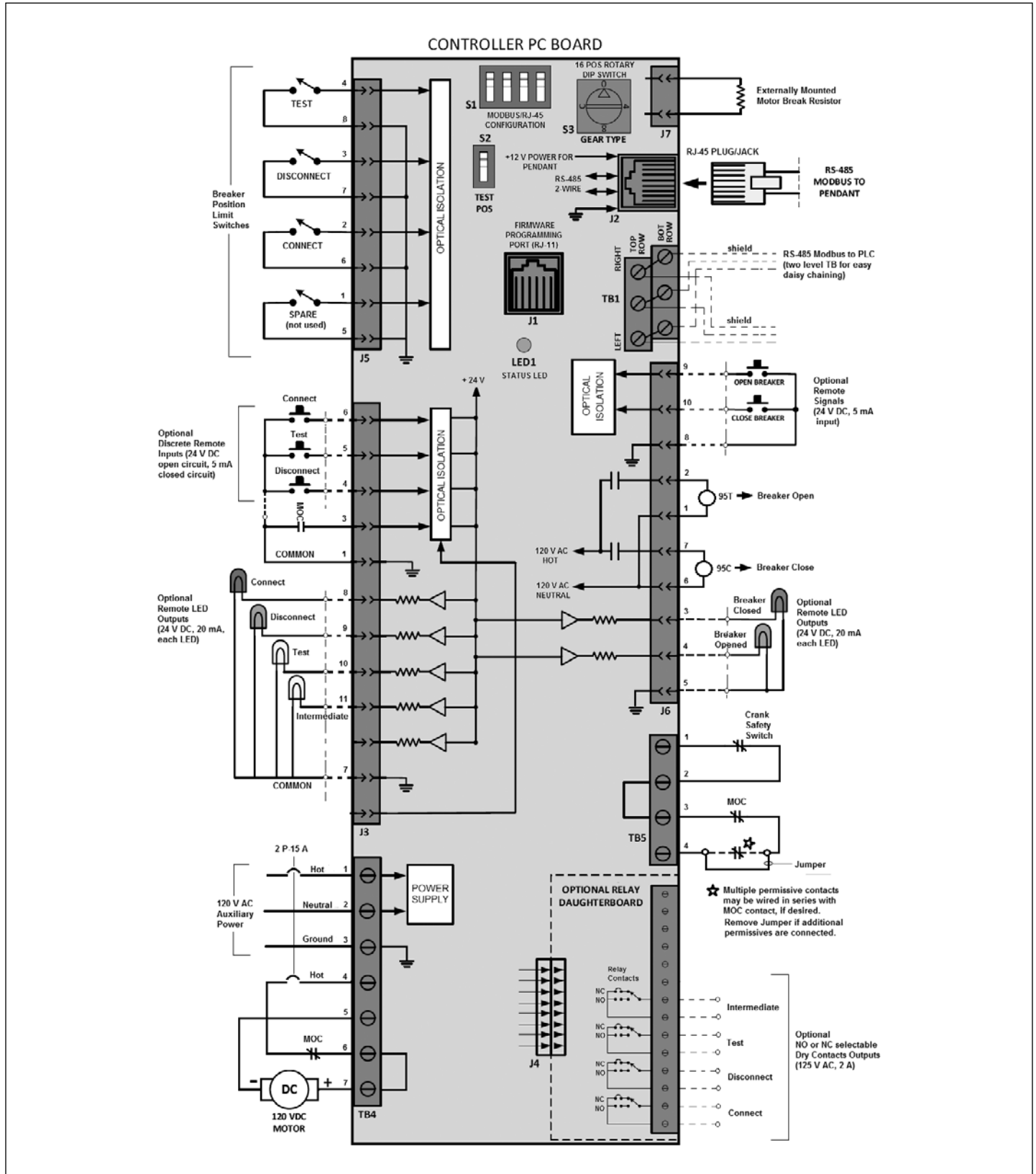

Figure 5.2-1. VC-W MR2 Controller Interface for a VCB with Distinct Test Position and Open/Close Functions

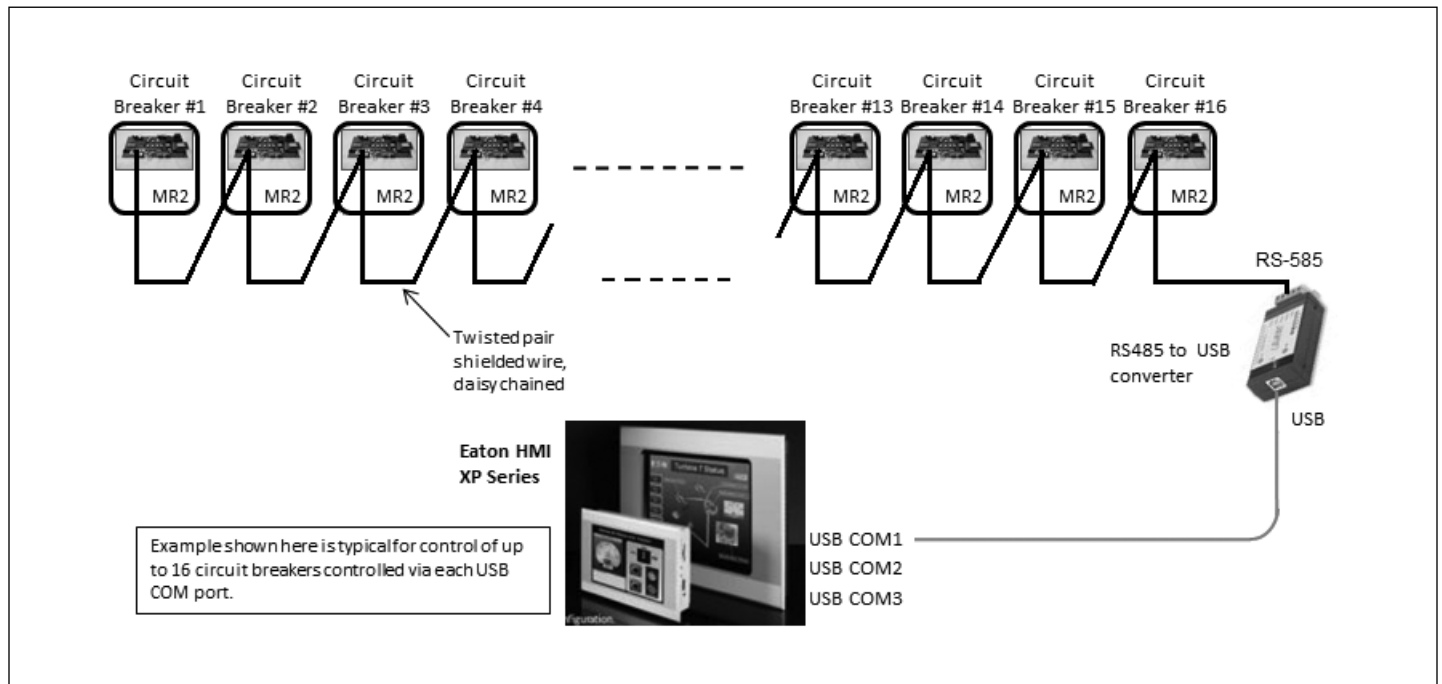

Figure 5.2-2. VC-W MR2 Typical Modbus Control Example

Accessories

Ground and Test Device

The ground and test device is a drawout element that may be inserted into a metal-clad switchgear housing in place of a circuit breaker to provide access to the primary circuits to permit the temporary connection of grounds or testing equipment to the high-voltage circuits. High potential testing of cable or phase checking of circuits are typical tests which may be performed. The devices are insulated to suit the voltage rating of the switchgear and will carry required level of short-circuit current.

Before using ground and test devices, it is recommended that each user develop detailed operating procedures consistent with safe operating practices. Only qualified personnel should be authorized to use ground and test devices.

Manual and electrical ground and test devices are available. These devices include six studs for connection to primary circuits. On the manual device, selection and grounding is accomplished by cable or bus bars connection. On electrical-type devices, grounding is accomplished by an electrically operated grounding switch.

Standard Accessories

- One test jumper
- One levering crank
- One maintenance tool
- One lifting yoke (5–27 kV)
- One set of rails (5–27 kV)

Optional Accessories

- Transport dolly (5–27 kV), (5–15 kV arc-resistant)
- Portable lifter (5–27 kV)
- Test cabinet
- Electrical levering device (5–38 kV)
- Ramp for lower breaker (5–27 kV), (5–15 kV arc-resistant)
- Manual or electrical ground and test device
- Hi-pot tester
- Integral motorized remote racking (VC-W MR2) for circuit breaker
- Integral motorized remote racking (VC-W MR2) for auxiliary drawer

Systems Options



InsulGard Relay



RFCT Sensor

Partial Discharge Equipment

Partial Discharge Sensing and Monitoring for Switchgear

Partial Discharge in Switchgear

Partial discharge is a common name for various forms of electrical discharges such as corona, surface tracking, and discharges internal to the insulation. It partially bridges the insulation between the conductors. These discharges are essentially small arcs occurring in or on the surface of the insulation system when voltage stress exceeds a critical value. With time, airborne particles, contaminants and humidity lead to conditions that result in partial discharges. Partial discharges start at a low level and increase as more insulation becomes deteriorated. Examples of partial discharge in switchgear are surface tracking across bus insulation, or discharges in the air gap between the bus and a support, such as where a bus passes through an insulating window between the sections of the switchgear. If partial discharge process is not detected and corrected, it can develop into a full-scale insulation failure followed by an electrical fault. Most switchgear flashover and bus failures are a result of insulation degradation caused by various forms of partial discharges.

Sensing and Monitoring

Eaton's Type VCP-W metal-clad switchgear (2.4–38 kV) is corona-free by design. Corona emissions within the standard VacClad switchgear assemblies have been eliminated or reduced to very low levels by special fabrication and assembly techniques, such as rounding and buffing of all sharp copper edges at the joints, employing star washers for bolting metal barriers, and using specially crafted standoff insulators for primary bus supports. By making switchgear assemblies corona-free, Eaton has made its standard switchgear more reliable. However, as indicated above, with time, airborne particles, contaminants and humidity lead to conditions that cause partial discharges to develop in switchgear operating at voltages 4000 V and above. Type VC-W switchgear can be equipped with factory-installed partial discharge sensors and partial discharge sensing relay for continuous monitoring of the partial discharges under normal operation. Timely detection of insulation degradation through increasing partial discharges can identify potential problems so that corrective actions can be planned and implemented long before permanent deterioration develops. Partial discharge detection can be the foundation of an effective predictive maintenance program. Trending of partial discharge data over time allows prediction of failures, which can be corrected before catastrophic failure occurs.



InsulGard Relay (PD Monitoring)

The PD sensing and monitoring system is optional. It consists of Eaton's InsulGard™ Relay and PD sensors specifically developed for application in the switchgear to work with the relay.

Partial discharges within the switchgear compartment are detected by installation of a small donut type radio frequency current transformer (RFCT) sensor over floating stress shields of the specially designed bus or line side primary bushings. Partial discharges in customer's power cables (external discharges) are detected by installation of the RFCT around ground shields of the incoming or outgoing power cables termination.

In 5/15 kV switchgear (refer to **Figure 5.2-4**), primary epoxy bushings with stress shield and RFCT sensors for measurement of internal as well as external partial discharges are all optional. InsulGard relay is also optional. When specified, one set of primary epoxy bushings (located on bus side) with stress shield and associated RFCT sensor is provided at every two vertical sections. An additional RFCT sensor for each incoming and outgoing power cable circuits can be provided as required. The RFCT output signals can be connected directly to InsulGard relay for continuous monitoring of partial discharges or can be used for periodic field measurements.

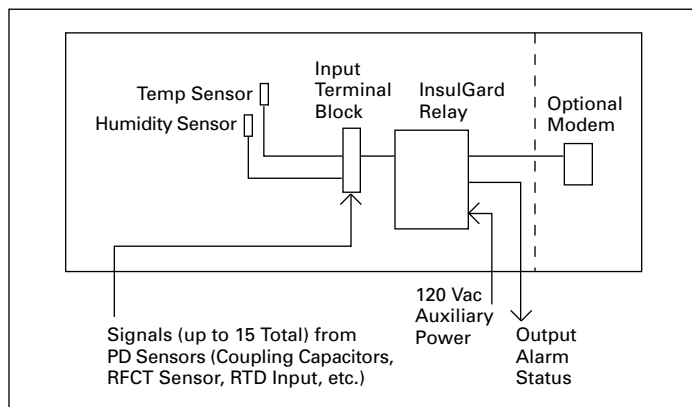

Figure 5.2-3. InsulGard Relay System

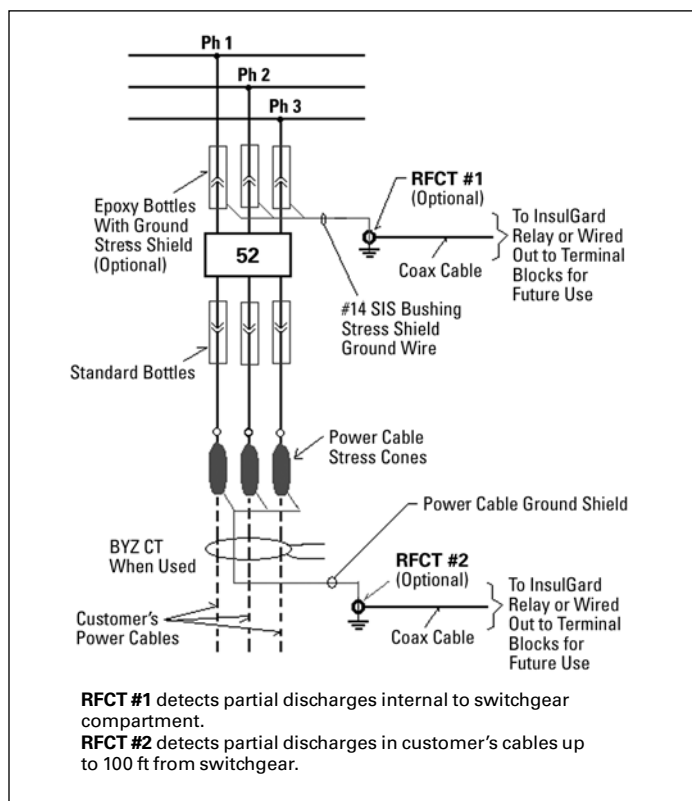

Figure 5.2-4. Typical Partial Discharge Sensor Connections (5-15 kV Switchgear)

Note: Use one set of epoxy bottles with ground stress shield on bus side (either in the top or bottom compartment) at every two vertical sections. Use standard bottles at all other locations.

Partial Discharge Sensors and Monitoring for Switchgear

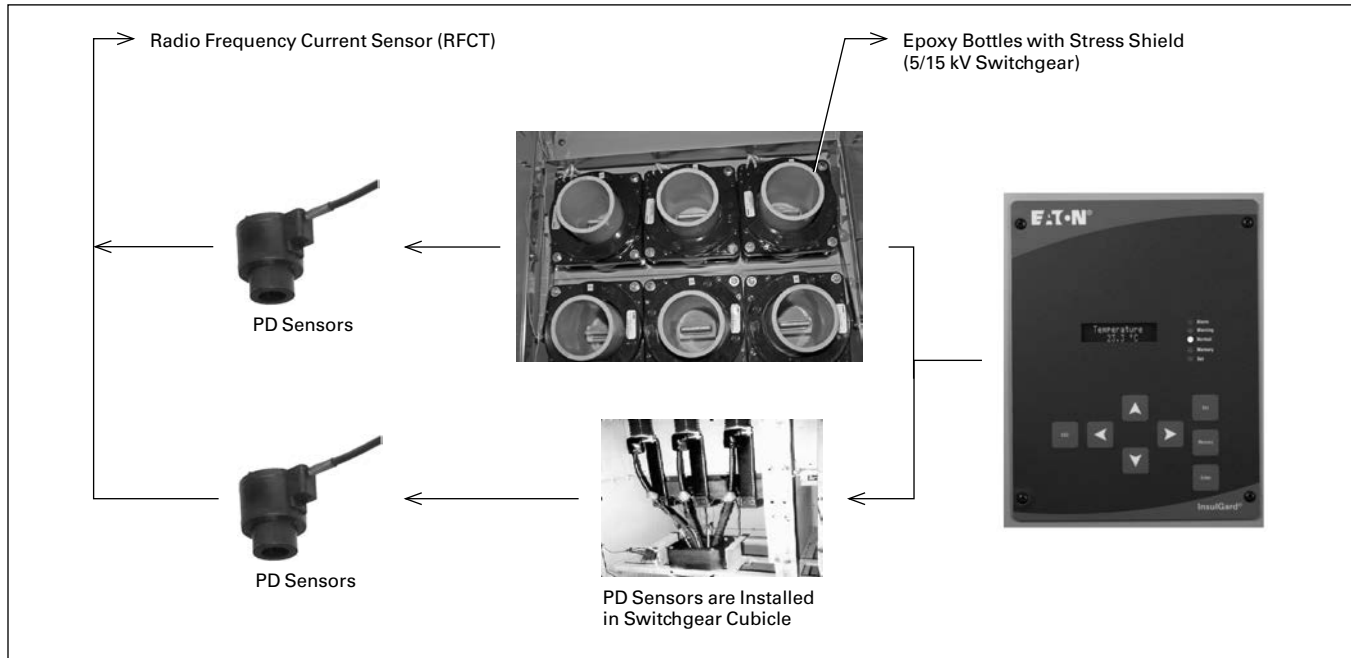

Figure 5.2-5. How the Process Works—Sensing and Data Collection

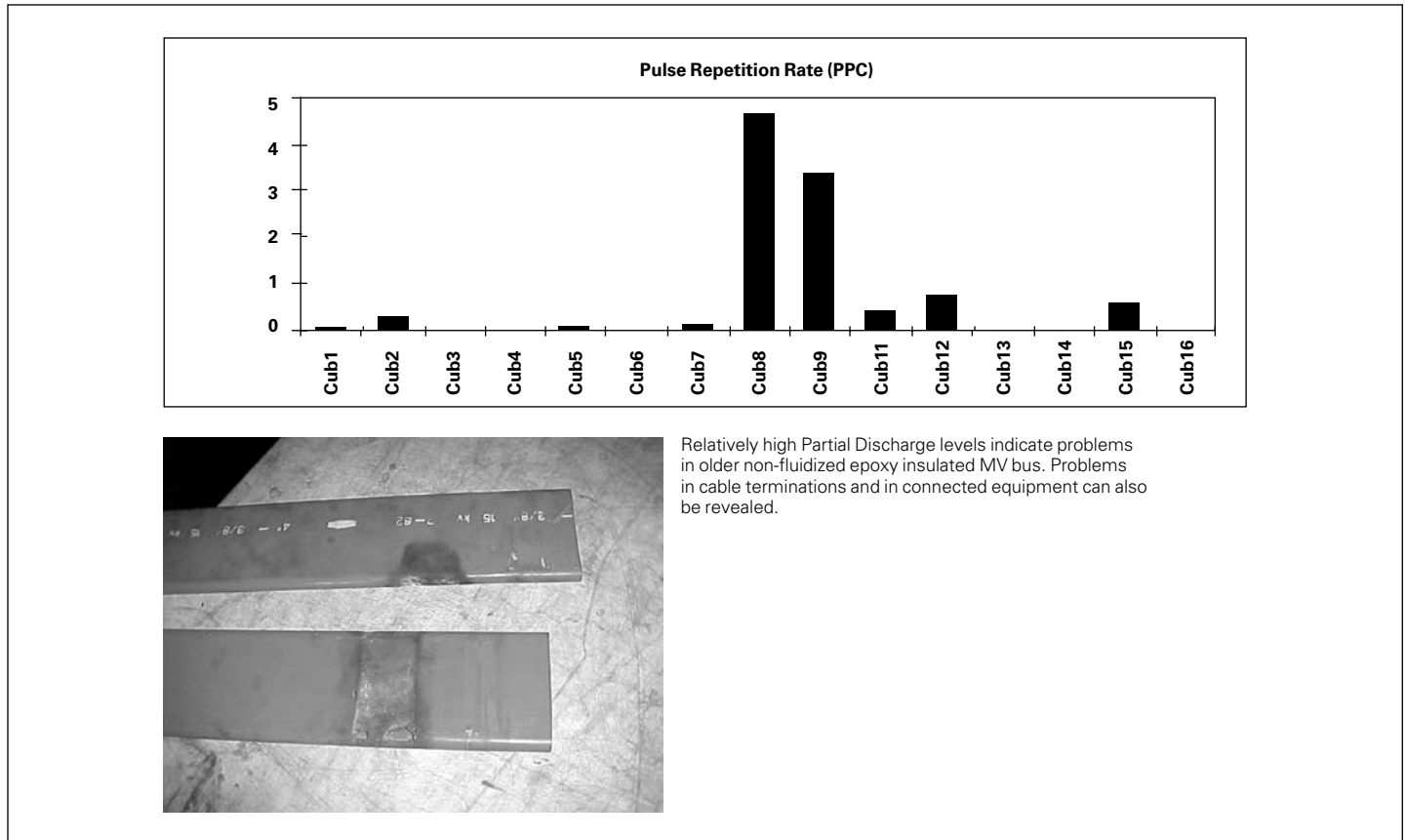

Figure 5.2-6. How the Process Works—Data Analysis and Report (Sample)

Standard Layouts

Typical Units—Indoor

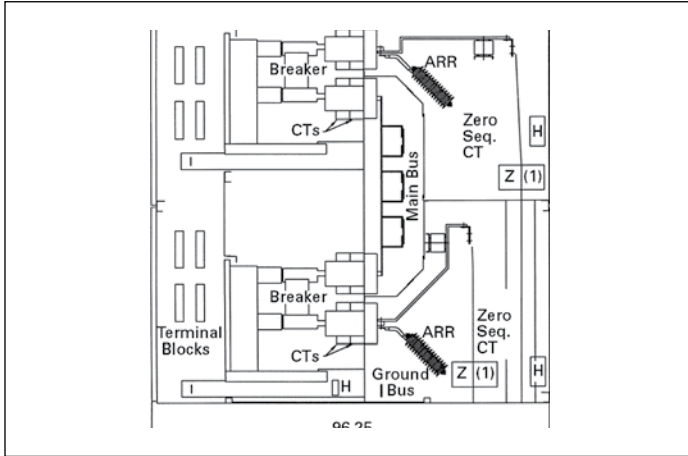

Figure 5.2-7. 26.00-Inch (660.4 mm) Wide Typical Breaker/Breaker Vertical Section—Dimensions in Inches (mm)

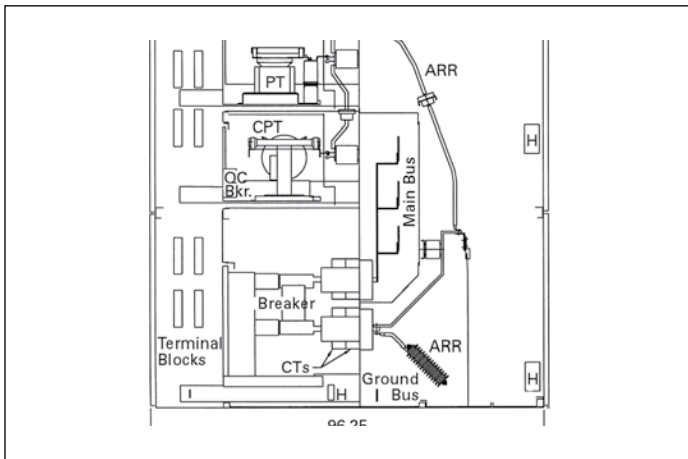

Figure 5.2-8. 26.00-Inch (660.4 mm) Wide Typical Auxiliary/Breaker Vertical Section—Dimensions in Inches (mm)

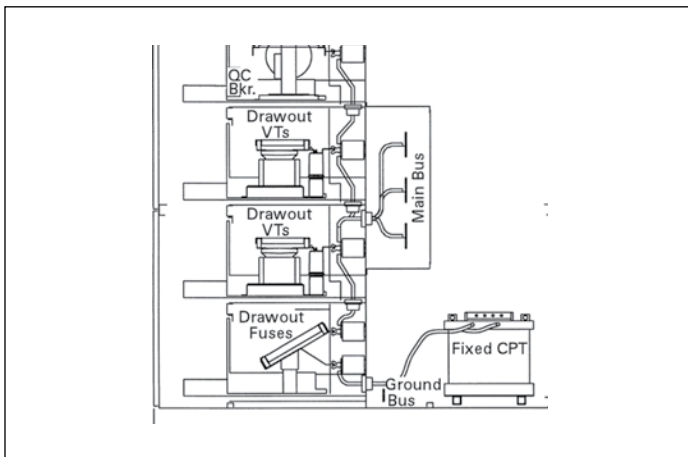

Figure 5.2-9. 26.00-Inch (660.4 mm) Wide Typical Auxiliary/Auxiliary Vertical Section—Dimensions in Inches (mm)

Tie Breaker Bus Transition Requirements

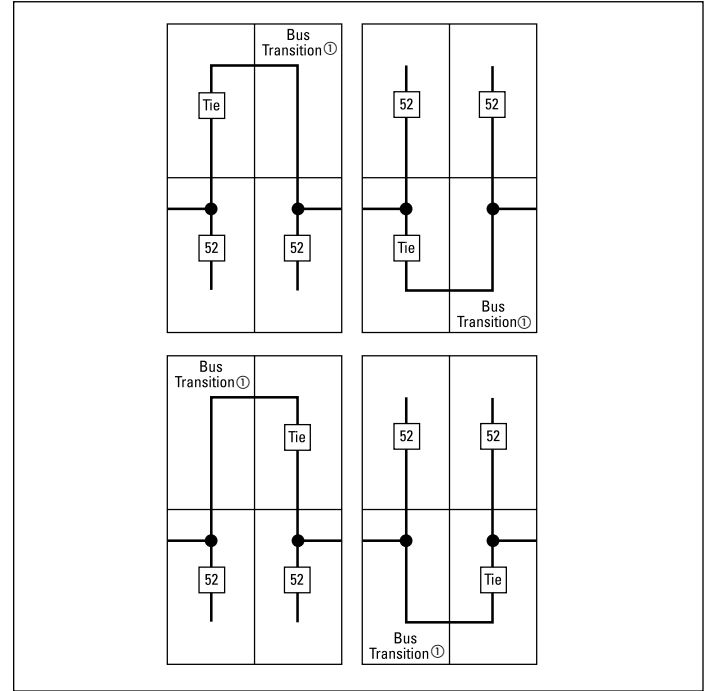

Figure 5.2-10. Tie Breaker Bus Transition Requirements

① Breakers cannot be located in bus transition compartment.

Available Configurations

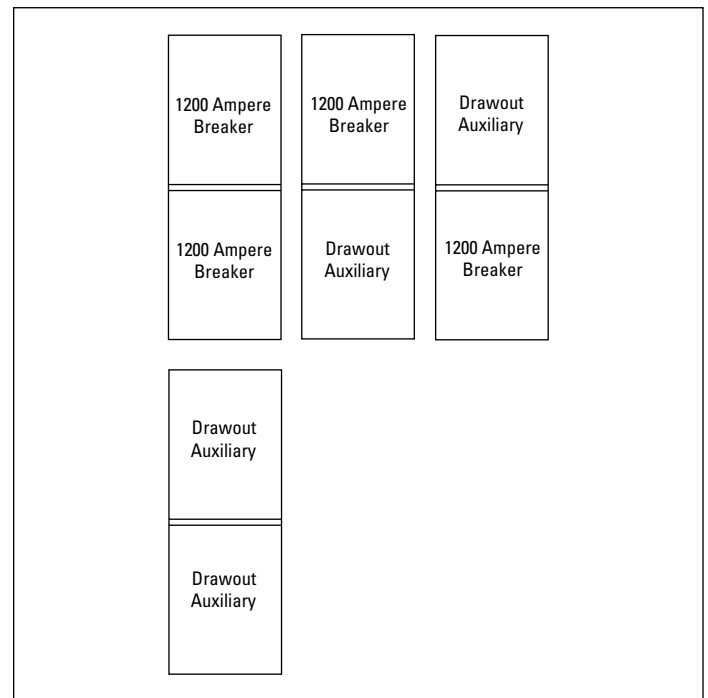

Figure 5.2-11. Available Configurations

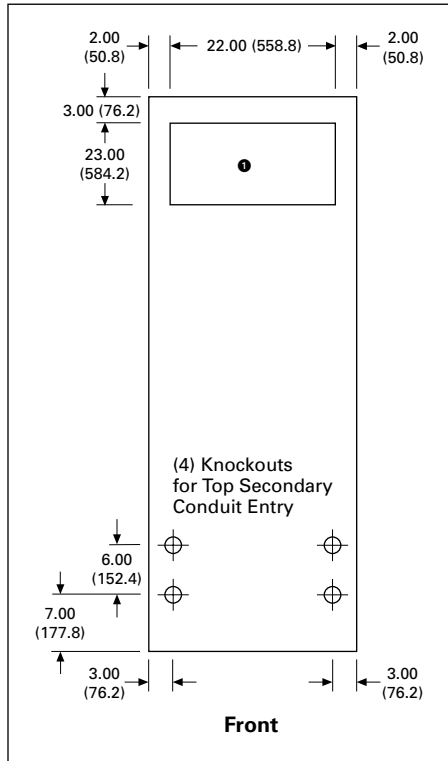

Figure 5.2-12. Top View of Typical Indoor Breaker and Auxiliary Structures—Dimensions in Inches (mm)

① Power cable entrance area. Refer to **Figure 5.2-14** for typical conduit locations. Refer to shop drawings for order specific locations.

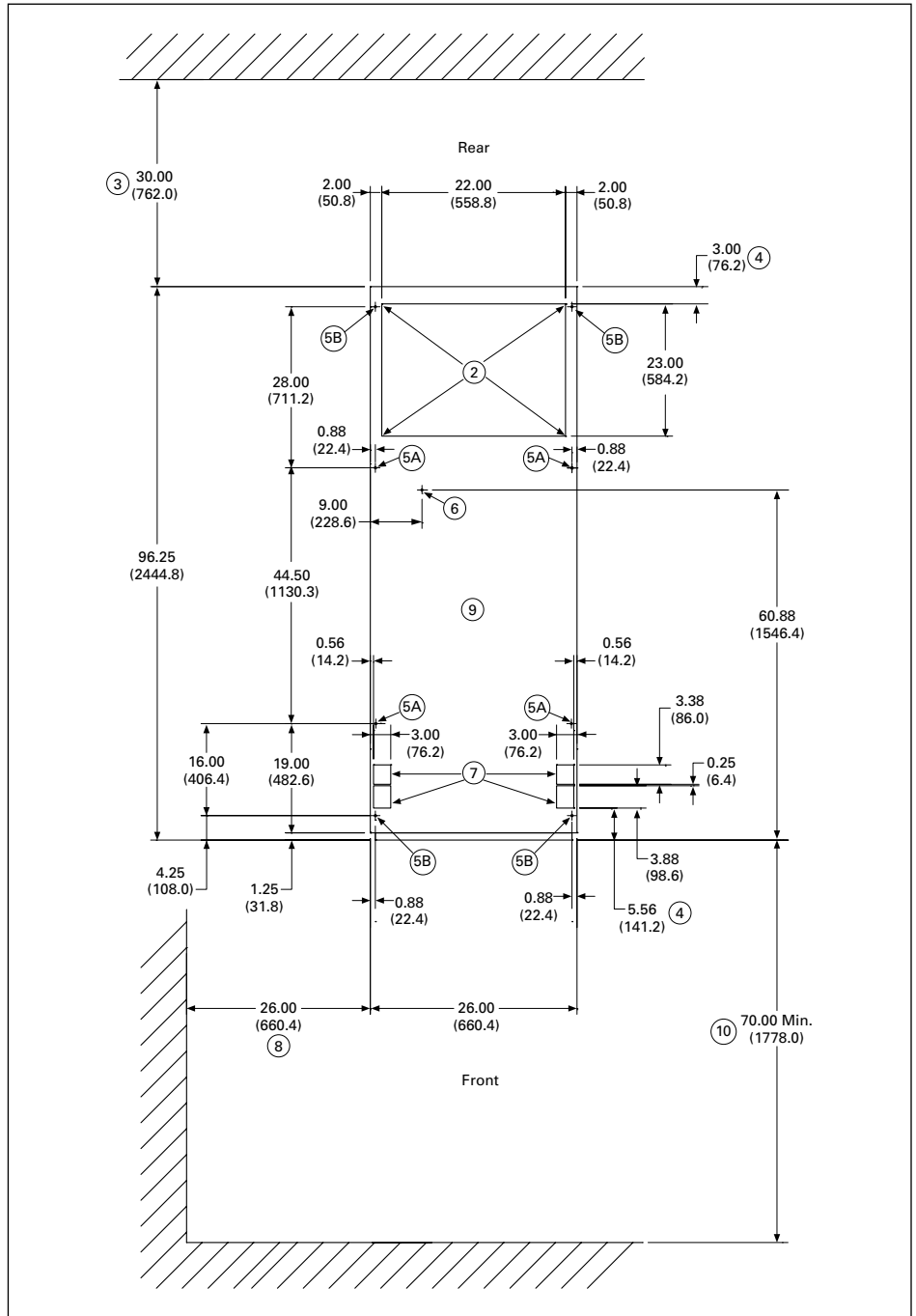

Figure 5.2-13. Base Plan of a Typical Indoor Breaker or Auxiliary Structure

- ② Power cable entrance area. Refer to **Figure 5.2-14** for typical conduit locations. Refer to shop drawings for order specific locations.
- ③ Recommended minimum clearance to rear of VacClad-W.
- ④ Floor steel, if used, must not exceed this dimension under VacClad-W.
- ⑤ Anchor locations: 5A and 5B for seismic applications, 5A only for non-seismic application. For indoor, use 0.5-inch (12.7 mm) bolts or weld.
- ⑥ Station ground connection provision.
- ⑦ Secondary conduit space: All—maximum of 1.00-inch (25.4 mm) projection.
- ⑧ Minimum clearance to LH side of VacClad-W. Minimum clearance to RH side of the switchgear: 6.00 inches (152.4 mm).
- ⑨ Finished foundation surface shall be level within 0.06-inch (1.5 mm) in 36.00 inches (914.4 mm) left-to-right, front-to-back, and diagonally, as measured by a laser level.
- ⑩ Minimum clearance to front of VacClad-W.

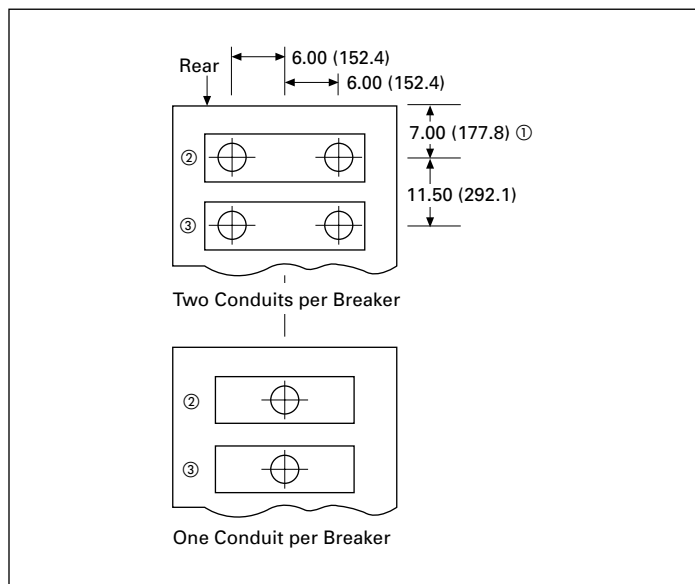

Figure 5.2-14. Primary Conduit Locations for Stacked Breakers

- ① Changes to 8.25 (209.6 mm) if optional hinged rear doors are required.
- ② When cables enter from top, they connect to the breaker located in the bottom compartment. When cables enter from bottom, they connect to the breaker in the upper compartment.
- ③ When cables enter from top, they connect to the breaker located in the upper compartment. When cables enter from bottom, they connect to the breaker in the bottom compartment.

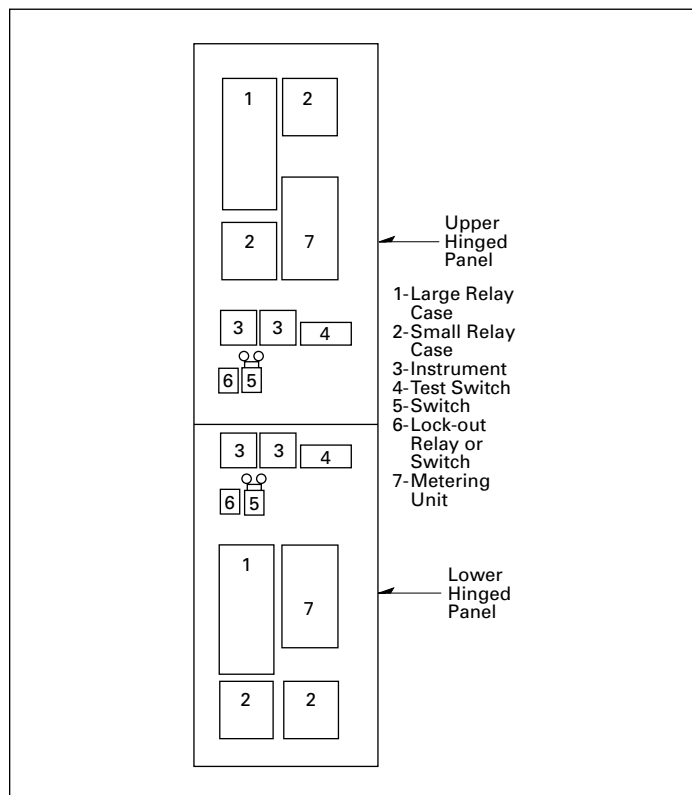

Figure 5.2-15. Maximum Hinged Panel Equipment

Note: The figure above shows that the arrangement of components differs between upper and lower panels. The figure may also be used to select custom arrangements of hinged panel components. Also, the use of multi-function relays such as Eaton's E-series relays will significantly reduce consumption of panel space.

Dimensions for estimating purposes only.

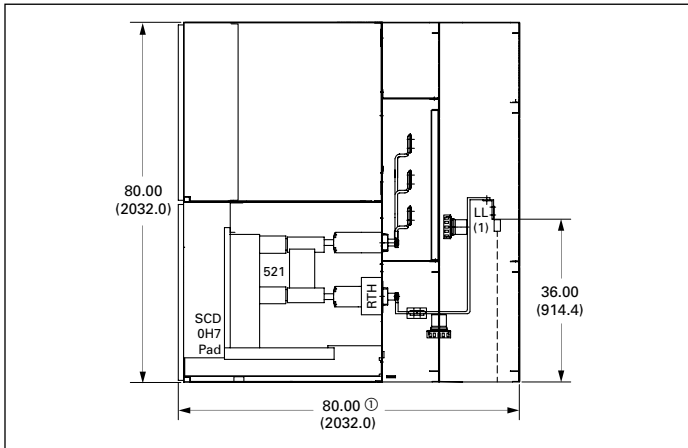

Figure 5.2-16. 5 kV, 1200A, 250 MVA VCP-W ND Low Profile 26.00-Inch (660.4 mm) Wide Indoor Unit, Blank/Breaker—Dimensions in Inches (mm)

① Depth can be reduced to 72.00 inches (1828.8 mm) if power cables enter from top.

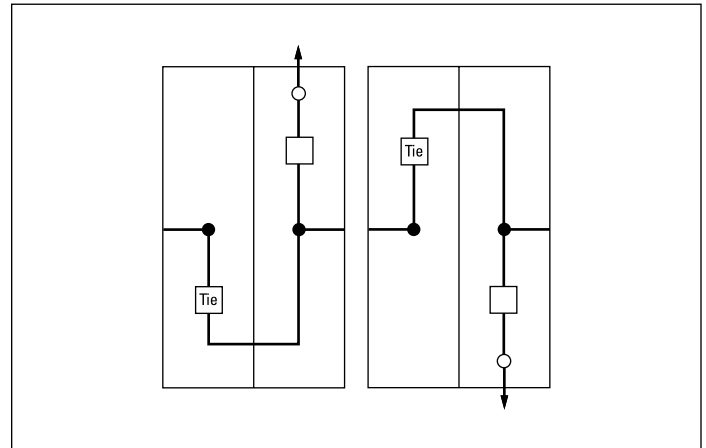

Figure 5.2-19. Tie Breaker Bus Transition Requirements

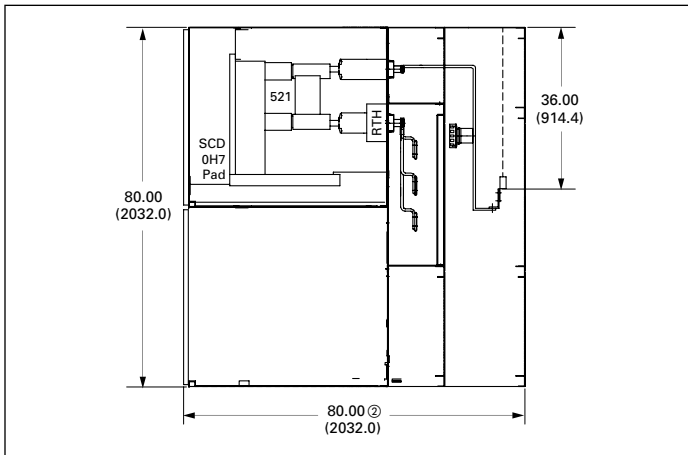

Figure 5.2-17. 5 kV, 1200A, 250 MVA VCP-W ND Low Profile 26.00-Inch (660.4 mm) Wide Indoor Unit, Breaker/Blank—Dimensions in Inches (mm)

② Depth can be reduced to 72.00 inches (1828.8 mm) if power cables enter from below.

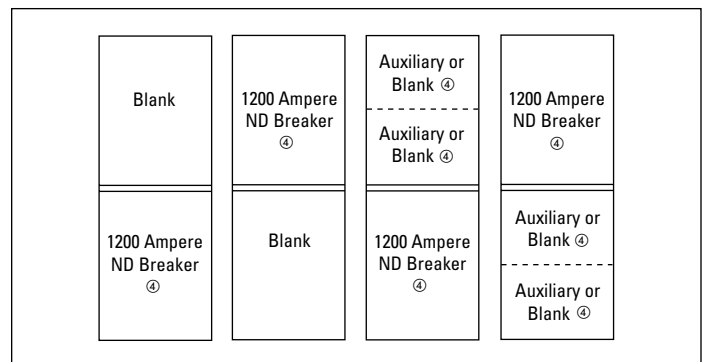

Figure 5.2-20. Available Configurations (Front View)

④ Relays or control devices cannot be mounted on the circuit breaker or auxiliary compartment door.

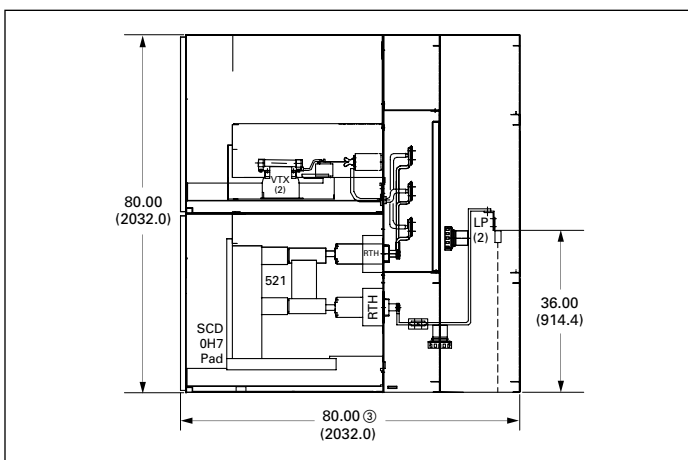

Figure 5.2-18. 5 kV, 1200A, 250 MVA VCP-W ND Low Profile 26.00-Inch (660.4 mm) Wide Indoor Unit, Auxiliary/Breaker—Dimensions in Inches (mm)

③ Depth can be reduced to 72.00 inch (1831.7 mm) if power cables enter from top.

Weights

Table 5.2-8. Switchgear Assembly (Less Breaker)

Type of Vertical Section	Main Bus Rating, Amperes	Weight Lb (kg)
B/B	1200	2000 (908)
	2000	2200 (999)
B/A or A/B	1200	1500 (682) 1700 (772)
	2000	1700 (772) 1900 (863)
A/A	1200	1400 (636) 1600 (726)
	2000	1600 (726) 1800 (817)

Table 5.2-9. Circuit Breaker ①

Type of Circuit Breaker	Current Rating, Amperes	Weight Lb (kg) (Static)
50 VCPW-ND-250	1200	345 (157)

① Breaker impact weight = 1.5 x static weight.

Control Power

Table 5.2-10. VCP-W Breaker Stored Energy Mechanism Control Power Requirements

Rated Control Voltage	Spring Charging Motor			Close or Trip Amperes	UV Trip mA Maximum	Voltage Range		Indicating Light Amperes
	Inrush Amperes	Run Amperes	Average Run Time, Sec.			Close	Trip	
48 Vdc	36.0	9	6	16	200	38–56	28–56	0.02
125 Vdc	16.0	4	6	7	80	100–140	70–140	0.02
250 Vdc	9.2	2	6	4	40	200–280	140–280	0.02
120 Vac	16.0	4	6	6	—	104–127	104–127	0.02
240 Vac	9.2	2	6	3	—	208–254	208–254	0.02

Table 5.2-11. Control Power Transformers—Single-Phase, 60 Hz ②

Rated Primary Voltage, Volt	Rated Secondary Voltage, Volt	kVA	kV Class
2400	240–120	5, 10, 15	5
4160	240–120	5, 10, 15	5
4800	240–120	5, 10, 15	5
7200	240–120	5, 10, 15	15
8400	240–120	5, 10, 15	15
12470	240–120	5, 10, 15	15
13200	240–120	5, 10, 15	15
13800	240–120	5, 10, 15	15
23000	240–120	5, 10, 15	27
34500	240–120	15, 25	38 ③

② Line-to-line connection only available. Refer to Eaton for other voltages and kVA ratings.

③ 150 kV BIL.

Operations

Table 5.2-12. Breaker Operations Information

Circuit Breaker Ratings			Maximum Number of Operations ①			
Rated Maximum Voltage kV rms	Rated Continuous Current Amperes	Rated Short-Circuit Current kA rms, sym.	Between Servicing	No-Load Mechanical	Rated Continuous Current Switching	Inrush Current Switching
4.76, 8.25, 15	1200, 2000	33 kA and below	2000	10,000	10,000	750

① Each operation is comprised of one closing plus one opening.

Heat Loss

Table 5.2-13. Heat Loss in Watts at Full Rating, at 60 Hz

Type of Switchgear Assembly	Breaker Rating	1200 A	2000 A	2500 A	3000 A	4000 A Fan Cooled
VCP-W	5, 15, and 27 kV	600 W	1400 W	—	2100 W	3700 W
VCP-W	38 kV	850 W	1700 W	2300 W	3800 W	—

Other Components

Each CT, standard accuracy	50 W
Each CT, high accuracy	100 W
Each VT	60 W
CPT single-phase, 25 kVA	450 W
CPT single-phase, 45 kVA	892 W
Space heater — each	250 W

Typical Schematics

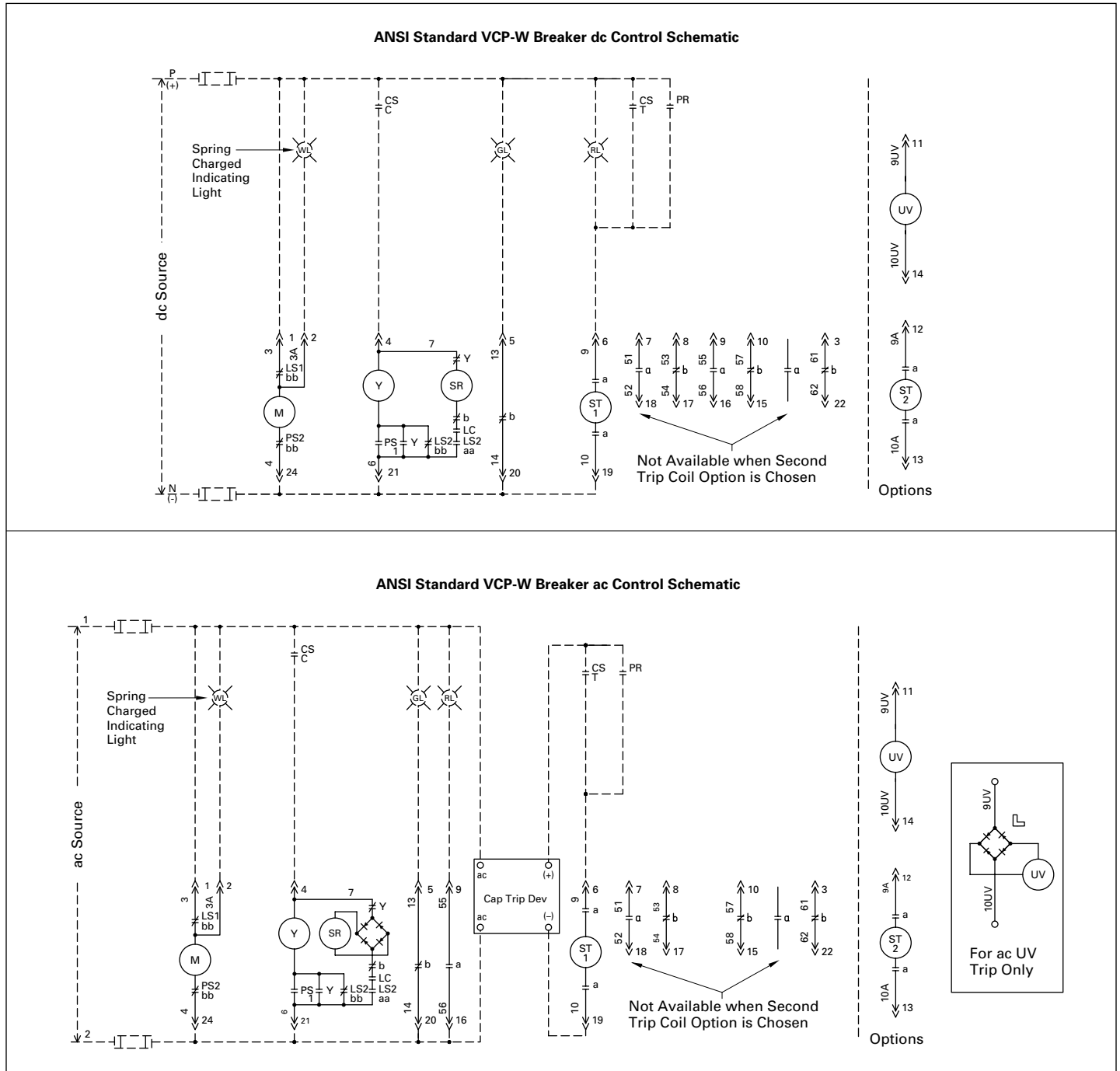

Figure 5.2-21. Typical 5/15/27 kV VCP-W "dc" and "ac" Control Schematics

Note: **CS** = Breaker Control Switch–Close
C = Breaker Control Switch–Trip
Y = Anti Pump Relay
SR = Spring Release Coil (Coil)
M = Spring Charge Motor
ST = Shunt Trip
PR = Protective Relay
 \wedge = Secondary Disconnect

Note: **LS1** = Closed until springs are fully charged.
bb = Closed until springs are fully charged.
LS2 = Open until springs are fully charged.
aa = Open until springs are fully charged.
LS2 = Closed until springs are fully charged.
bb = Closed until mechanism is reset.
LC = Open until mechanism is reset.
PS1 = Open in all except between "Test" and "Connected" positions.
PS2 = Closed in all except between "Test" and "Connected" positions.

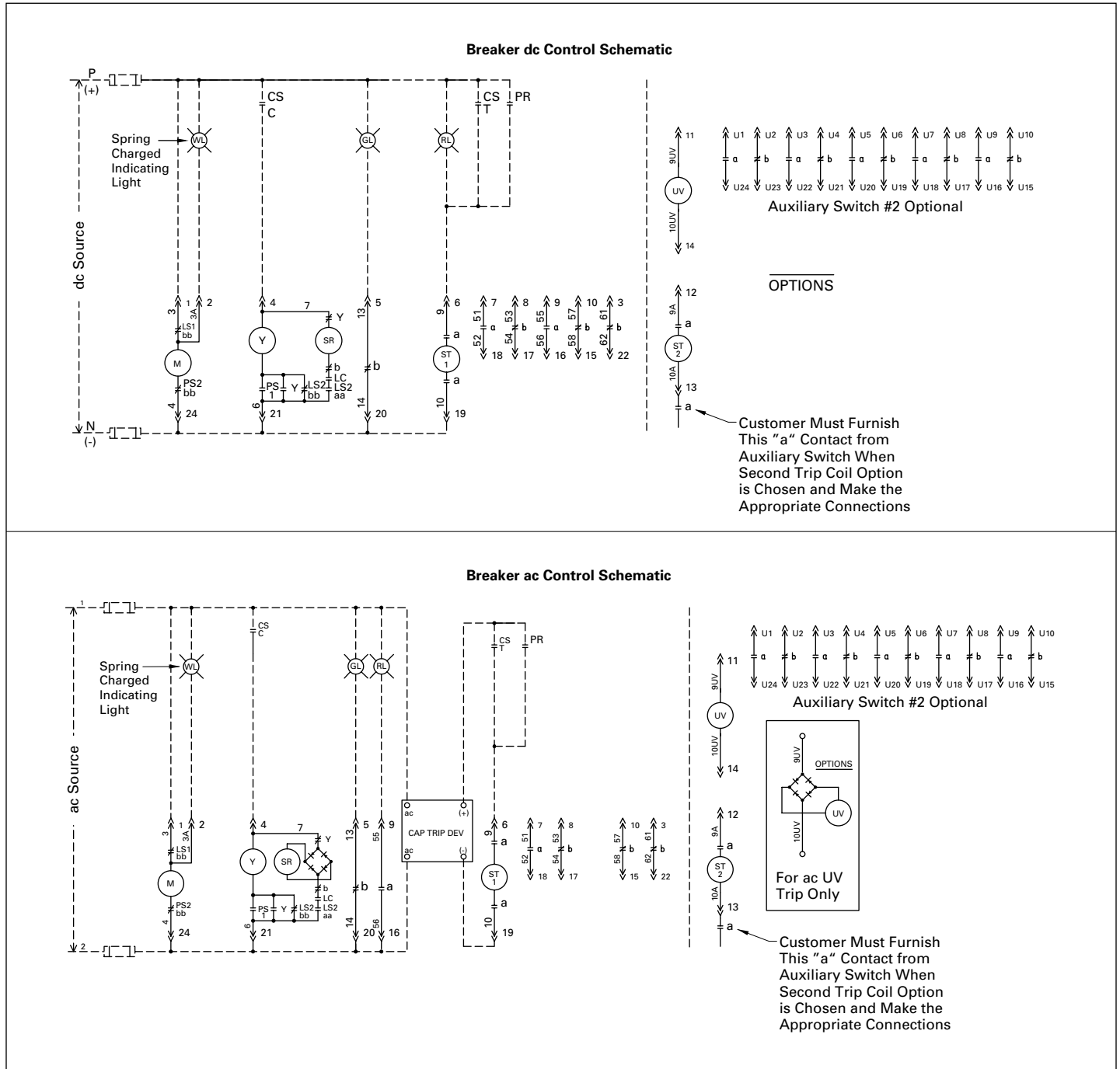

Figure 5.2-22. Typical 38 kV VCP-W "dc" and "ac" Control Schematics

Note: **CS** = Breaker Control Switch—Close
C = Breaker Control Switch—Close
CS = Breaker Control Switch—Trip
T = Breaker Control Switch—Trip
Y = Anti Pump Relay
SR = Spring Release Coil (Coil)
M = Spring Charge Motor
ST = Shunt Trip
PR = Protective Relay
^ = Secondary Disconnect

Note: **LS1** = Closed until springs are fully charged.
bb = Closed until springs are fully charged.
LS2 = Open until springs are fully charged.
aa = Open until springs are fully charged.
LS2 = Closed until springs are fully charged.
bb = Open until mechanism is reset.
PS1 = Open in all except between "Test" and "Connected" positions.
PS2 = Closed in all except between "Test" and "Connected" positions.

Eaton
1000 Eaton Boulevard
Cleveland, OH 44122
United States
Eaton.com

© 2019 Eaton
All Rights Reserved
Printed in USA
Publication No. CA022014EN / Z22944
June 2019



Eaton is a registered trademark.
All other trademarks are property
of their respective owners.