

Medium-voltage power distribution and control systems > Switchgear >

VacClad-W 38 kV, metal-clad medium-voltage switchgear

Contents

General Description	5.6-2
Standard Metal-Clad Switchgear Assembly Ratings .	5.6-8
Unusual and Usual Service Conditions	5.6-9
Devices	5.6-10
Circuit Breakers	5.6-10
Protection Relays and Metering	5.6-14
Instrument Transformers	5.6-14
Dummy Element	5.6-15
Integral Motorized Remote Racking Option (VC-W MR2)	5.6-16
Accessories	5.6-20
System Options	5.6-21
Layouts and Dimensions	5.6-24
Standard	5.6-24
Application Data	5.6-27
Heat Loss	5.6-27
Weights	5.6-27
Control Power	5.6-27
Typical Schematics	5.6-28

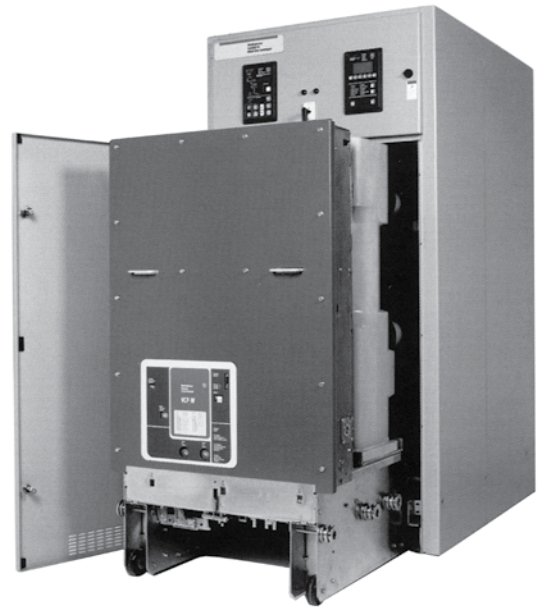

EATON

Powering Business Worldwide



More about this product
[Eaton.com/mva](https://www.eaton.com/mva)



Complete library of design guides
[Eaton.com/designguides](https://www.eaton.com/designguides)

General Description

38 kV Metal-Clad Switchgear

Eaton's VacClad switchgear family is designed for use in applications with distribution voltages up to 38 kV maximum. Typical applications include not only new construction but also replacement for older air-break, minimum oil or SF6 switchgear. The circuit breaker and switchgear will meet industry requirements for greater safety, quality, superior reliability and minimal maintenance while providing higher insulation levels in less space than other breaker types, thus reducing overall switchgear size for significant space savings.

Ratings

- Maximum rated voltage: 38 kV rms
- BIL withstand: 150 kV peak
- Maximum symmetrical interrupting with K = 1: 16 kA, 25 kA, 31.5 kA, 40 kA rms, and 35 kA rms (21 kA rating with K = 1.65)
- Continuous current:
 Circuit breakers—up to 2500 A
 Switchgear main bus—up to 3000 A

Features—38 kV Vacuum Circuit Breaker

- Corona-free design increases circuit breaker reliability and in-service life by maintaining insulation integrity
- Superior cycloaliphatic epoxy insulation—a void-free insulating material with outstanding electrical and mechanical characteristics, such as track resistance, dielectric strength, and fungus resistance, even in harsh industrial environment—is used throughout the circuit breaker as primary phase-to-phase and phase-to-ground insulation
- Axial-magnetic, copper-chrome contacts are used in 38 kV vacuum interrupters to provide superior dielectric strength, better performance characteristics, and lower chop current
- High power laboratory tests prove VCP-W breakers are capable of 50 to 200 full fault current interruptions
- V-Flex (stiff-flexible) current transfer from the vacuum interrupter moving stem to the breaker primary disconnecting contact is a non-sliding/non-rolling design, which eliminates maintenance required with the sliding/rolling type transfer arrangements. The V-Flex system provides excellent electrical and thermal transfer, and long vacuum interrupter life
- Easy inspection and accessibility is afforded by front mounted stored energy operating mechanism. The same basic mechanism is used on all ratings, which requires a minimum investment in spare parts
- All 38 kV circuit breakers are horizontal drawout design, which provide connect, test and disconnect position. A latch secures the breaker in the connected and disconnected/test position. The circuit breaker is designed to roll directly on the floor

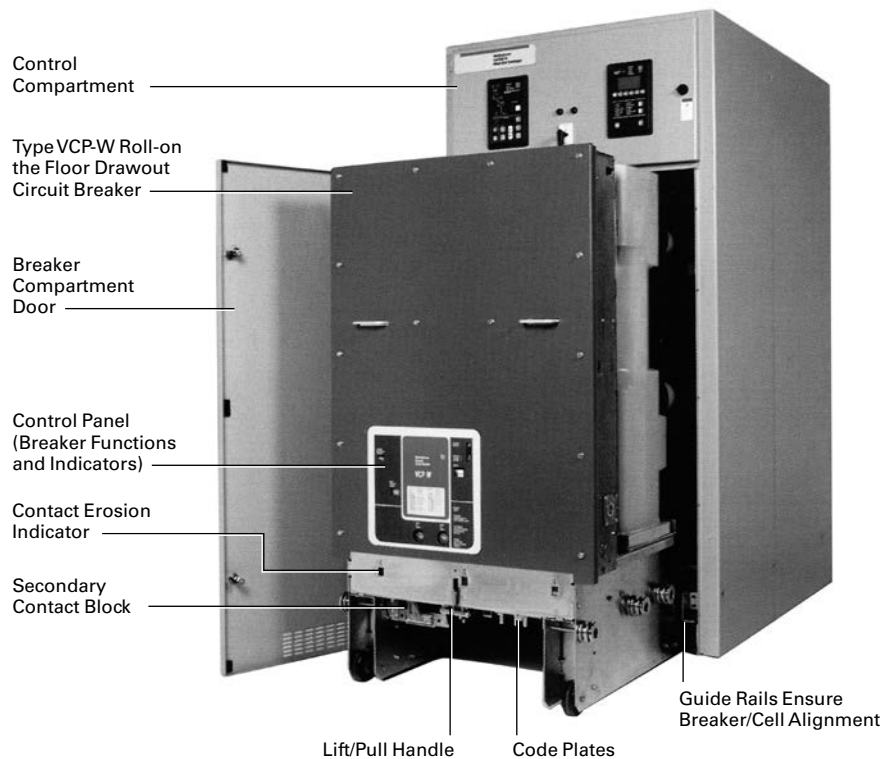

38 kV Breaker—Fully Withdrawn

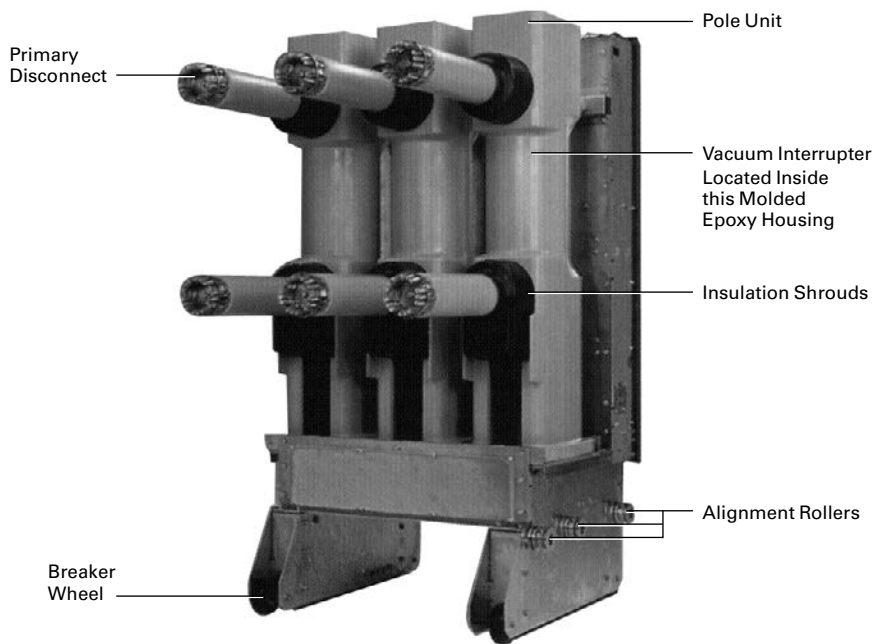

38 kV Breaker—Rear View



38 kV Switchgear—Circuit Breaker Compartment

- All breaker controls and indicators are functionally grouped on the front control panel and include: main contact status, closing spring status, port for manual spring charging, close and trip button, and mechanical operations counter
- Clearly visible contact erosion indicator on the front of the breaker
- Trip-free interlocks prevent moving a closed circuit breaker into or out of the connected position
- Breaker cannot be electrically or mechanically closed when in the intermediate position
- Closing springs automatically discharge before moving the circuit breaker into or out of the enclosure
- Breaker frame remains grounded during levering and in the connected position
- Coding plates are provided to ensure only correct breaker rating can be installed in cell
- Quality Assurance Certificate is included with each circuit breaker

Features— 38 kV Switchgear Assembly

Like the circuit breaker described above, the 38 kV switchgear assembly is a corona-free metal-clad design. It incorporates many features and advantages of 5, 15 and 27 kV VacClad design, with additional modifications required for 38 kV application.

- Industry-leading cycloaliphatic epoxy supports are used for primary phase-to-phase and phase-to-ground insulation throughout, providing 150 kV BIL and 80 kV (1 minute) power frequency withstand capability
- All primary bus conductors are insulated for full 38 kV by fluidized epoxy coating. All buses are fabricated from 100% conductivity copper. Bus joints are silver- or tin-plated as required, and covered with Eaton’s pre-formed insulating boots to maintain metal-clad integrity
- Circuit breaker compartment is designed to interface with Type VCP-W 38 kV circuit breaker. It includes floor-mounted breaker pan assembly (levering assembly) with all safety interlocks required by the metal-clad design. Cell mounted guide rails accurately guide the breaker into the cell during levering, and ensure correct alignment of the circuit breaker primary disconnects with the cell primary contacts when breaker reaches connected position

- Coding plates are provided to ensure only correct breaker rating can be installed in the cell
- Automatic steel shutters cover cell primary contacts when circuit breaker is withdrawn from its connected position, to prevent persons from accidentally touching the stationary primary cell contacts. Each shutter can be padlocked in the closed or open position. It can also be manually latched open as required for maintenance
- A separate control compartment is provided for installation of protection, metering and control devices. No devices are located on circuit breaker compartment door
- Rear of the switchgear is divided in main bus and cable compartments, isolated from each other by grounded metal barriers. Sufficient space is available for customer’s top or bottom entry power cables. Bus duct terminations can also be supplied. A bare copper ground bus is provided along the entire lineup, with an extension in each cable compartment for termination of power cable shields
- Each 38 kV 150 kV BIL indoor structure is 42.00 inches (1066.8 mm) wide x 95.00 inches (2413 mm) high x 124.36 inches (3158.8 mm) deep. Also available are outdoor aisleless and outdoor sheltered aisle structures

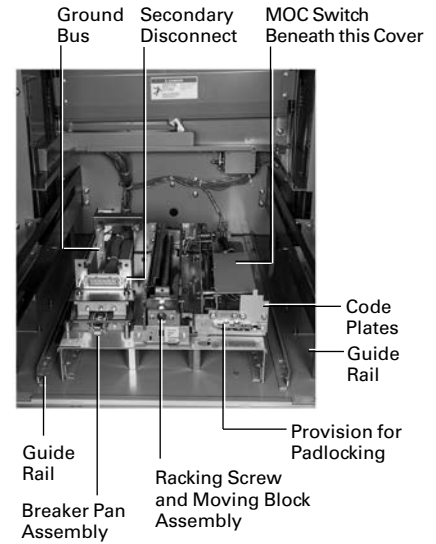

Breaker Levering Pan Assembly

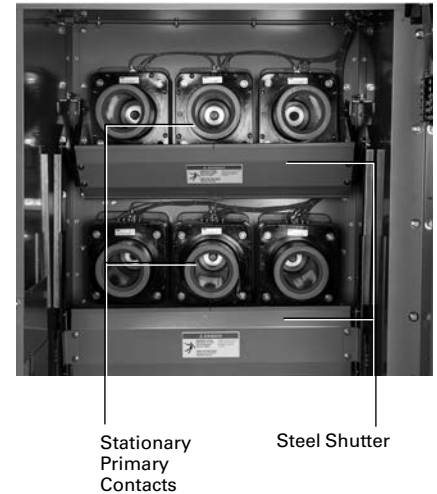

Breaker Compartment (Shutter Shown Open for Illustration)

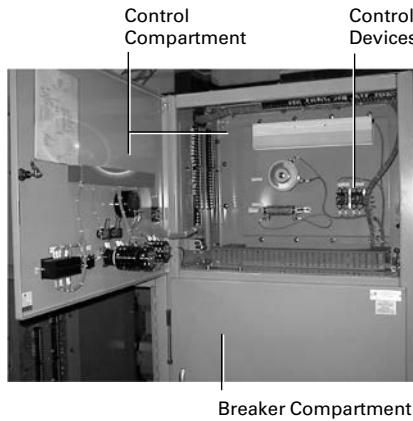

38 kV Switchgear—Control Compartment

- Voltage transformers are equipped with integral top-mounted primary fuses and installed in an auxiliary compartment. Two auxiliary compartments can be provided in one vertical section. Each auxiliary compartment can be supplied with 1, 2 or 3 VTs, and can be connected to bus or line, as required for a given application. The VTs assembly is located behind a fixed bolted panel, and provided with mechanism for moving it between connected and disconnected position. The VT assembly is interlocked with the fixed bolted panel such that the panel cannot be removed unless the VTs are withdrawn to disconnected position. A shutter assembly covers the primary stabs when VTs are withdrawn to disconnected position. A mechanism is also provided to automatically discharge VT primary fuses as the VTs are withdrawn from connected to disconnected position

- Ring type current transformers are installed over bus or line side primary insulating bushings, located behind the steel shutters, in the breaker compartment. In this design, the CTs are easily accessible from the front, after removal of the circuit breaker. The front accessibility permits adding or changing the CTs when the equipment is de-energized, but without removal of high-voltage joints or primary insulation. The design allows installations of two sets of standard or one set of high accuracy CTs on each side of the circuit breaker

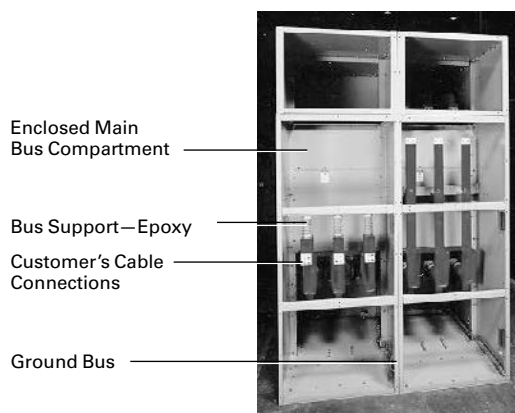

38 kV Switchgear Assembly—Rear View

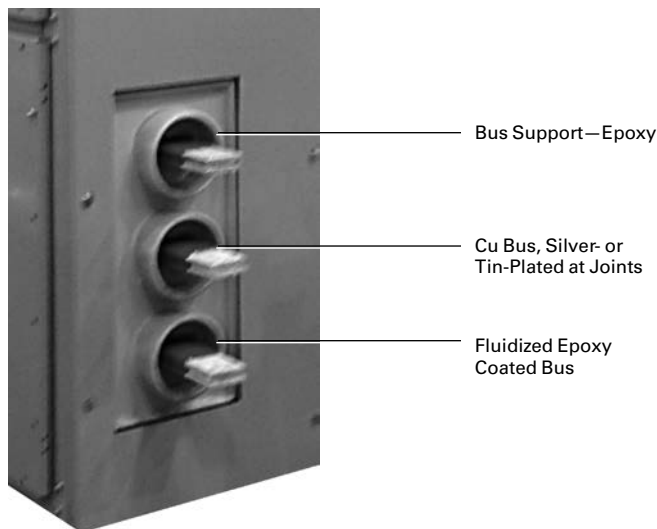

Main Bus

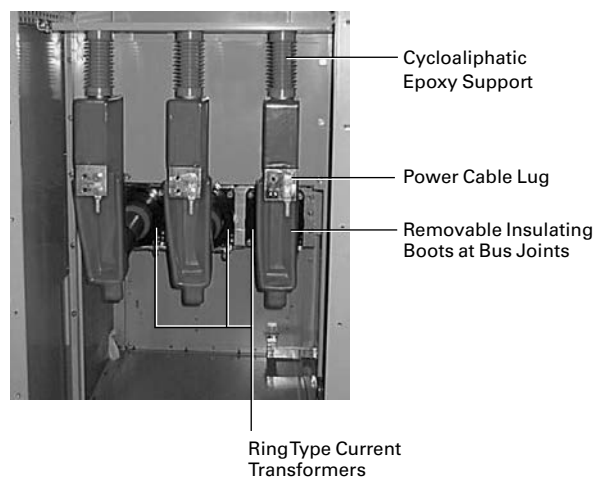

Rear Compartment (Partial)

38 kV, 150 kV BIL Design—Available Enclosures (42-Inch, 48-Inch and 60-Inch Wide Structures are Available)



Indoor Unit—Direct Roll-on-the-Floor Breaker

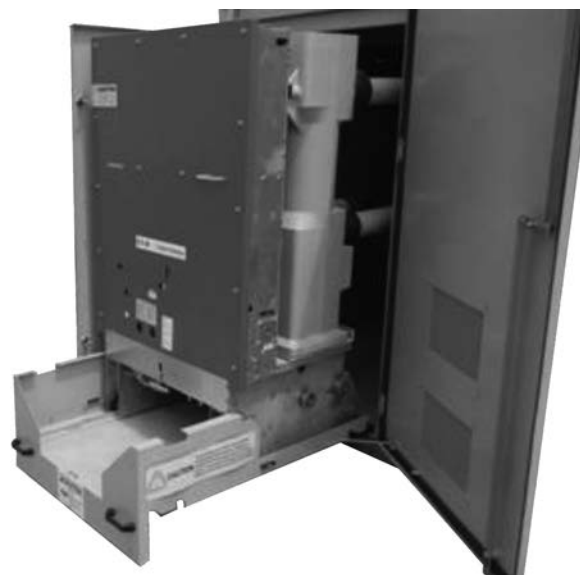

Breaker Removal Platform for Outdoor Aisleless



Non-Walk-In (OD Aisleless)



Walk-In (OD Sheltered Aisle)

Advantages

Eaton has been manufacturing metal-clad switchgear for over 60 years, and vacuum circuit breakers for more than 40 years. Tens of thousands of Eaton vacuum circuit breakers, used in a wide variety of applications, have been setting industry performance standards for years.

With reliability as a fundamental goal, Eaton engineers have simplified the VacClad-W switchgear design to minimize problems and gain trouble-free performance. Special attention was given to material quality and maximum possible use was made of components proven over the years in Eaton switchgear.

Maintenance requirements are minimized by the use of enclosed long-life vacuum interrupters. When maintenance or inspection is required, the component arrangements and drawers allow easy access. The light weight of the VacClad-W simplifies handling and relocation of the breakers.

Standards

Eaton's VacClad-W switchgear meets or exceeds ANSI/ IEEE C37.20.2 and NEMA® SG-5 as they apply to metal-clad switchgear. The assemblies also conform to Canadian standard CSA®-C22.2 No. 31-04, and EEMAC G8-3.2. Type VCP-W vacuum circuit breakers meet or exceed all ANSI and IEEE standards applicable to ac high-voltage circuit breakers rated on symmetrical current basis.

Metal-Clad Switchgear Compartmentalization

Medium-voltage metal-clad switchgear equipment conforming to C37.20.2 is a compartmentalized design, wherein primary conductors are fully insulated for the rated maximum voltage of the assembly, and all major primary circuit components are isolated from each other by grounded metal barriers. This type of construction minimizes the likelihood of arcing faults within the equipment and propagation of fault between the compartments containing major primary circuits.

The C37.20.2 metal-clad switchgear equipment is designed to withstand the effects of short-circuit current in a bolted fault occurring immediately downstream from the load terminals of the switchgear. The bolted fault capability is verified by short-time and momentary short-circuit withstand current testing on complete switchgear, as well as by fault making (close and latch) testing on the switching devices as shown in **Figure 5.6-1**.

The short-time current withstand tests demonstrate electrical adequacy of busses and connections against physical damage while carrying the short-circuit current for a given duration. The momentary current withstand tests demonstrate the mechanical adequacy of the structure, busses and connections to withstand electro-magnetic forces with no breakage of insulation. It should be noted that design testing of standard metal-clad switchgear does not involve any internal arcing faults.

VacClad is Corona Free

Corona emissions within the standard VacClad switchgear assemblies have been eliminated or reduced to very low levels by special fabrication and assembly techniques, such as rounding and buffing of all sharp copper edges at the joints, employing star washers for bolting metal barriers, and using specially crafted standoff insulators for primary bus supports. By making switchgear assemblies corona-free, Eaton has made its standard switchgear more reliable.

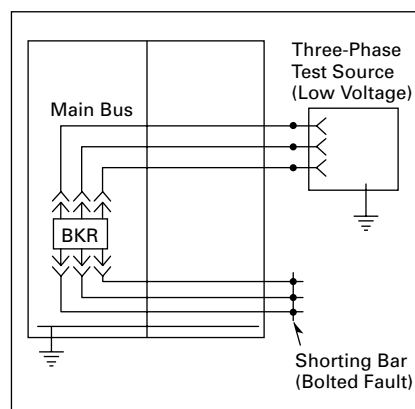

Figure 5.6-1. Metal-Clad Switchgear Short-Circuit and Momentary Withstand Tests

Standard Metal-Clad Switchgear Assembly Ratings

VacClad-W metal-clad switchgear is available for application at voltages up to 38 kV, 50 or 60 Hz. Refer to the table below for complete list of available ratings.

Table 5.6-1. Standard VCP-W (Non-Arc-Resistant) Metal-Clad Switchgear Ratings Per IEEE C37.20.2-2015 ①②

Rated Maximum Voltage	(Ref.) Rated Voltage Range Factor K	(Ref.) Rated Short-Circuit Current I	Insulation Level		Rated Main Bus Continuous Current ③④	Rated Short-Time Short-Circuit Current Withstand (2-Second) K*I ⑤	Rated Momentary Short-Circuit Current Withstand (10-Cycle) (167 ms)	
			Power Frequency Withstand Voltage, 60 Hz, 1 Minute kV rms	Lightning Impulse Withstand Voltage [LIWV] (BIL) kV Peak			2.7 *K*I ⑥	1.6 *K* I ⑦ (Ref. only) kA rms Asym.
4.76	1	25	19	60	1200, 2000, 3000, 4000	25	68	40
	1.24	29			1200, 2000, 3000, 4000	36	97	58
	1	40			1200, 2000, 3000, 4000	40	108	64
	1.19	41			1200, 2000, 3000, 4000	49	132	78
	1	50			1200, 2000, 3000, 4000	50	135	80
	1	63			1200, 2000, 3000, 4000	63	170	101
8.25	1.25	33	36	95	1200, 2000, 3000, 4000	41	111	66
	1	50			1200, 2000, 3000, 4000	50	135	80
15	1.3	18	36	95	1200, 2000, 3000, 4000	23	62	37
	1	25			1200, 2000, 3000, 4000	25	68	40
	1.3	28			1200, 2000, 3000, 4000	36	97	58
	1	40			1200, 2000, 3000, 4000	40	108	64
	1.3	37			1200, 2000, 3000, 4000	48	130	77
	1	50			1200, 2000, 3000, 4000	50	135	80
	1	63			1200, 2000, 3000, 4000	63	170	101
27	1	16	60	125	1200, 2000, 2500, 2700	16	43	26
	1	22			1200, 2000, 2500, 2700	22	60	35
	1	25			1200, 2000, 2500, 2700	25	68	40
	1	31.5			1200, 2000, 2500, 2700	31.5	85	51
	1	40			1200, 2000, 2500, 2700	40	108	64
38	1	16	80	150 ⑧	1200, 2000, 2500	16	43	26
	1	25			1200, 2000, 2500	25	68	40
	1	31.5			1200, 2000, 2500	31.5	85	51
	1.65	23			1200, 2000, 2500	35	95	56
	1	40			1200, 2000, 2500	40	108	64

① The switchgear assembly is designed for use with type VCP-W, VCP-WC and VCP-WG circuit breakers. However, please note that certain VCP-WC circuit breakers may have higher capabilities than required by ANSI standards. In such cases, switchgear assembly ratings as given in this table will apply.

② Switchgear assemblies can be supplied with UL/CSA label. Contact Eaton for availability.

③ Circuit breaker requires forced air cooling to carry 4000 A at 4.76, 8.25 and 15 kV, and 3000 A at 38 kV.

④ 27 kV 2500 A and 2700 A main bus ratings are available in two-high design configurations only.

⑤ Please note that use of certain current transformers (for example, bar type CTs) and protective devices may limit the duration to a value less than 2 seconds.

⑥ These values exceed 2.6*K*I required by IEEE C37.20.2-2015.

⑦ These values exceed 1.55*K*I required by IEEE C37.20.2-2015.

⑧ This is a standard IEEE C37.20.2 rating for 38 kV Class of switchgear.

Unusual and Usual Service Conditions

Unusual Service Conditions

Applications of metal-clad switchgear at other than usual altitude or temperature, or where solar radiation is significant, require special consideration. Other unusual service conditions that may affect design and application include:

- Exposure to salt air, hot or humid climate, excessive dust, dripping water, falling dirt, or other similar conditions
- Unusual transportation or storage conditions
- Switchgear assemblies when used as the service disconnecting means
- Installations accessible to the general public
- Exposure to seismic shock
- Exposure to nuclear radiation

Usual Service Conditions

Usual service conditions for operation of metal-clad switchgear are as follows:

- Altitude does not exceed 3300 feet (1000 m)
- Ambient temperature within the limits of -30 °C and +40 °C (-22 °F and +104 °F)
- The effect of solar radiation is not significant

Applications Above 3300 Feet (1006 m)

Equipment utilizing sealed interrupting devices (such as vacuum interrupters) does not require derating of rated maximum voltage. The rated one-minute power frequency withstand voltage, the impulse withstand voltage and the continuous current rating must be multiplied by the appropriate correction factor in **Table 5.6-4** to obtain modified ratings that must equal or exceed the application requirements.

Note: Intermediate values may be obtained by interpolation.

Applications Above or Below 40 °C Ambient

Refer to ANSI C37.20.2, Section 8.4 for load current-carrying capabilities under various conditions of ambient temperature and load.

Applications at Frequencies Less Than 60 Hz

Rated Short-Circuit Current

Based on series of actual tests performed on Type VCP-W circuit breakers and analysis of these test data and physics of vacuum interrupters, it has been found that the current interruption limit for Type VCP-W circuit breakers is proportional to the square root of the frequency. **Table 5.6-2** provides derating factors, which must be applied to breaker interrupting current at various frequencies.

Table 5.6-2. Derating Factors

Interrupting Current Derating Factors				
50 Hz	25 Hz	16 Hz	12 Hz	
None	0.65	0.52	0.45	

Rated Short-Time and Close and Latch Currents

No derating is required for short time and close and latch current at lower frequency.

Rated Continuous Current

Because the effective resistance of circuit conductors is less at lower frequency, continuous current through the circuit can be increased somewhat. **Table 5.6-3** provides nominal current rating for VCP-W breakers when operated at frequencies below 60 Hz.

Table 5.6-3. Current Ratings

Rated Continuous Current at 60 Hz	Nominal Current at Frequency Below 60 Hz			
	50 Hz	25 Hz	16 Hz	12 Hz
1200 A	1243	1410	1519	1589
2000 A	2075	2374	2573	2703
3000 A	3119	3597	3923	4139

Power Frequency and Impulse Withstand Voltage Ratings

No derating is required for lower frequency.

CTs, VTs, Relays and Instruments

Application at frequency other than rated frequency must be verified for each device on an individual basis.

Table 5.6-4. Altitude Derating Factors

Altitude Above Sea Level in Feet (m)	Altitude Correction Factor to be Applied to:	
	Voltage	Rated Continuous Current
3300 (1006) (and Below)	1.0	1.0
4000 (1219)	0.98	0.995
5000 (1524)	0.95	0.991
6000 (1829)	0.92	0.987
6600 (2012)	0.91	0.985
7000 (2137)	0.89	0.98
8000 (2438)	0.86	0.97
9000 (2743)	0.83	0.965
10,000 (3048)	0.80	0.96
12,000 (3658)	0.75	0.95
13,200 (4023)	0.72	0.94
14,000 (4267)	0.70	0.935
16,000 (4877)	0.65	0.925
16,400 (5000)	0.64	0.92
18,000 (5486)	0.61	0.91
20,000 (6096)	0.56	0.90

Load Current Switching

Table 5.6-6 showing number of operations is a guide to normal maintenance for circuit breakers operated under usual service conditions for most repetitive duty applications including isolated capacitor bank switching and shunt reactor switching, but not for arc furnace switching. The numbers in the table are equal to or in excess of those required by ANSI C37.06.

Circuit Breakers

Table 5.6-5. Available 38 kV VCP-W Vacuum Circuit Breaker Types Rated on Symmetrical Current Rating Basis, Per ANSI Standards ①②③

Identification			Rated Values											Related Required Capabilities						Asymmetry Factor for VCP-W Breakers
Circuit Breaker Type	Nominal Voltage Class	Nominal 3-Phase MVA Class	Voltage		Insulation Level		Current		Rated Transient Recovery Voltage			Rated Interrupting Time	Rated Permissible Tripping Delay	Rated Reclosing Time	Rated Maximum Voltage Divided by K	Current Values				
			Rated Maximum Voltage	Rated Voltage Range Factor	Power Frequency Withstand Voltage (1 min.)	Lightning Impulse Withstand Voltage (1.2 x 50 μs)	Rated Continuous Current at 60 Hz	Rated Short-Circuit Current (at Rated Maximum kV)	Rated Crest Voltage	Rated Time to Crest	Rate of Rise of Recovery Voltage ⑥					Maximum Sym. Interrupting Capability	3-Second Short-Time Current Carrying Capability	Closing and Latching Capability (Momentary) ⑧		
	kV Class	MVA Class	V kV rms	K ④	kV rms	kV Crest ⑤	Amp	I ④ kA rms	E2 kV Crest	T2 μs	kV/μs	⑦ Cycles	Y ⑧ Sec.	⑨ ms	V/K kV rms	KI kA rms	KI kA rms	2.7 K Times Rated Short-Circuit Current	1.6 K Times Rated Short-Circuit Current	
380VCP-W 16	34.5	—	38	1.0	80	170 ⑩	1200 2000	16	71	125	0.64	5	2	300	38	16	16	43	26	1.2
380VCP-W 21	34.5	—	38	1.65	80	170 ⑩	1200 2000	21	71	125	0.64	5	2	300	23	35	35	95	56	1.2
380VCP-W 25	34.5	—	38	1.0	80	170 ⑩	1200 2000	25	71	125	0.64	5	2	300	38	25	25	68	40	1.2
380VCP-W 32	34.5	—	38	1.0	80	170 ⑩	1200 2000 2500	31.5	71	125	0.64	5	2	300	38	31.5	31.5	85	51	1.2
380VCP-W 40	34.5	—	38	1.0	80	170 ⑩	1200 2000 2500	40	71	125	0.64	5	2	⑪	38	40	40	108	64	1.2

① For capacitor switching, refer to Table 5.6-7.

② 38 kV breakers are not UL listed.

③ Circuit breakers shown in this table were tested in accordance with IEEE standard C37.09-1979.

④ For three-phase and line-to-line faults, the symmetrical interrupting capability at an operating voltage

$$I_{sc} = \frac{V}{V_o} \text{ (Rated Short-Circuit Current)}$$

But not to exceed KI.

Single line-to-ground fault capability at an operating voltage

$$I_{sc} = 1.15 \frac{V}{V_o} \text{ (Rated Short-Circuit Current)}$$

But not to exceed KI.

The above apply on predominately inductive or resistive three-phase circuits with normal-frequency line-to-line recovery voltage equal to the operating voltage.

⑤ 3000 A continuous rating is available for 38 kV. Contact Eaton for details.

$$\textcircled{6} \text{ RRRV} = 1.137 \frac{E_2}{T_2}$$

⑦ 3-cycle rating available, refer to Table 5.6-7.

⑧ Tripping may be delayed beyond the rated permissible tripping delay at lower values of current in accordance with the following formula:

$$T \text{ (seconds)} = Y \left(\frac{K \text{ Times Rated Short-Circuit Current}}{\text{Short-Circuit Current Through Breaker}} \right)^2$$

The aggregate tripping delay on all operations within any 30-minute period must not exceed the time obtained from the above formula.

⑨ For reclosing service, there is **No derating** necessary for Eaton's VCP-W family of circuit breakers. **R = 100%**. Type VCP-W breaker can perform the O-C-O per ANSI C37.09; O-0.3s-CO-15s-CO per IEC 56; and some VCP-Ws have performed O-0.3s-CO-15s-CO-15s-CO; **all with no derating**. Contact Eaton for special reclosing requirements.

⑩ For higher close and latch ratings, refer to Table 5.6-7.

⑪ Included for reference only.

⑫ Asymmetrical interrupting capability = "S" times symmetrical interrupting capability, both at specified operating voltage.

⑬ ANSI standard requires 150 kV BIL. All 38 kV ratings are tested to 170 kV BIL.

⑭ Type 380VCP-W 40 circuit breaker is not rated for rapid reclosing.

Industry Leader VCP-WC

Introducing the VCP-WC extra capability medium-voltage drawout circuit breaker. Designed to provide all the industry-leading features expected of the VCP-W, plus extra capabilities for those application requirements that go beyond what is usually experienced. The performance enhancement features of the VCP-WC make it an ideal choice for capacitor switching duty, high altitude applications, transformer secondary fault protection, locations with concentrations of rotating machinery or high operating endurance requirements, just to mention a few. Consider these capability enhancements:

- Definite purpose capacitor switching
- Higher close and latch
- Faster rate of rise of recovery voltage
- Higher short-circuit current
- Higher mechanical endurance
- Higher insulation level
- Higher voltage ratings with K=1
- 3-cycle interrupting time
- Higher switching life
- Designed and tested to ANSI standards and higher
- WR fixed retrofit configuration available

Vacuum Circuit Breaker Design Leadership

Eaton is a world leader in vacuum interrupter and vacuum circuit breaker technology, offering VCP-WC with extra capabilities without sacrificing the proven features already standard with other VCP-W circuit breakers. Features such as:

- Vacuum interrupters with copper-chrome contacts
- V-Flex non-sliding current transfer system
- Visible contact erosion indicators
- Visible contact wipe indicators
- Front, functionally grouped controls and indicators
- Epoxy insulation (27/38 kV)
- Front, vertically mounted stored energy mechanism
- Drawout on extension rails
- Integrally mounted wheels
- Quality Assurance Certificate

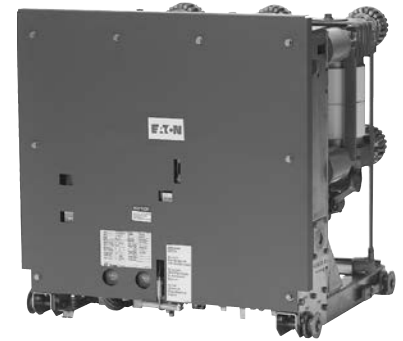

The Type VCP-WC Breakers are not Interchangeable with Standard VCP-W Breakers. They are Equipped with Different Code Plates and Taller Front Panels.

Load Current Switching

Table 5.6-6 showing number of operations is a guide to normal maintenance for circuit breakers operated under usual service conditions for most repetitive duty applications including isolated capacitor bank switching and shunt reactor switching, but not for arc furnace switching. The numbers in the table are equal to or in excess of those required by ANSI C37.06.

Table 5.6-6. Breaker Operations Information

Circuit Breaker Ratings			Maximum Number of Operations ①			
Rated Maximum Voltage kV rms	Rated Continuous Current Amperes	Rated Short-Circuit Current kA rms, sym.	Between Servicing	No-Load Mechanical	Rated Continuous Current Switching	Inrush Current Switching
4.76, 8.25, 15	1200, 2000	33 kA and below	2000	10,000	10,000	750
4.76, 8.25, 15	3000	All	1000	5000	5000	400
4.76, 15	All	37 kA and above	1000	5000	5000	400
27	All	All	500	2500	2500	100
38	All	All	250	1500	1500	100

① Each operation is comprised of one closing plus one opening.

Table 5.6-7. VCP-WC Ratings (Symmetrical Current Basis), Rated K = 1

Identification Circuit Breaker Type	Rated Values													Capacitor Switching Ratings					Mechanical Endurance No-Load Operations
	Voltage		Insulation Level		Continuous Current at 60 Hz	Current					Maximum Permissible Tripping Delay	Rate of Rise of Recovery Voltage (RRRV) ④	General Purpose		Definite Purpose				
	Maximum Voltage (V) kV rms	Voltage Range Factor K	Power Frequency Withstand Voltage (1 min.) kV rms	Lightning Impulse Withstand Voltage (1.2 x 50 μs) kV Peak		Sym. Interrupting at Voltage (Isc) kA rms Total	% dc Component (Idc)	Asym. Interrupting (It) kA rms	Closing and Latching Capability kA Peak	Short-Time Current for 3 Seconds ② kA rms			Interrupting Time ③ ms	Cable Charging Current A rms	Isolated Shunt Capacitor Bank Current A rms	Back-to-Back Capacitor Switching			
																Capacitor Bank Current A rms	Inrush Current kA Peak	Inrush Frequency kHz	
380VCP-W 16C	38	1	80	170	1200 2000	16	75	23.3	50	16	50	2.0	0.7 1.3	50 50	250 250 & 1000	250 250 & 1000	20 20 & 20	4.4 5 & 5	10,000
380VCP-W 25C	38	1	80	170	1200 2000	25	65	34.0	75	25	50	2.0	0.7 1.3	50 50	250 250 & 1000	250 250 & 1000	20 20 & 20	4.4 5 & 5	10,000
380VCP-W 32C	38	1	80	170	1200 2000 2500 3000FC ⑤	33.1	57	42.5	91	31.5	50	2.0	0.7 1.3 0.7 1.3	50 50 50 50	250 250 & 1000 —	250 250 & 1000 —	20 20 & 20 —	4.4 5 & 5 —	10,000
380VCP-W 40C	38	1	80	170	1200 2000 2500 3000FC ⑥	40	63	53.5	107	40	50	2.0	0.7	50 50 50 50	⑦	⑦	⑦	⑦	10,000

② Except as noted.

③ 3 cycles.

④ Contact Eaton for higher RRRV or for more information.

⑤ 2000 A FC to 3000 A.

⑥ 2500 A FC to 3000 A.

⑦ Tested at 27 kV, 350 A isolated or back-to-back capacitor bank, inrush current 4.6 kA, inrush frequency 1.2 kHz.

Note: 38 kV, 2500 A and 3000 AWC breakers are not rated for rapid reclosing.

Type VCP-W Circuit Breaker Operating Times

The closing time (initiation of close signal to contact make) and opening time (initiation of the trip signal to contact break) are shown in **Table 5.6-8**. **Figure 5.6-2** shows the sequence of events in the course of circuit interruption, along with applicable VCP-W circuit breaker timings.

Table 5.6-8. Closing Time and Opening Time

Rated Control Voltage	Breaker Rating	Closing Time Milliseconds	Opening Time Milliseconds	
			Standard 5-Cycle Breaker	Optional 3-Cycle Breaker
48V, 125V, 250Vdc	All	45–60	30–45	30–38
120V, 240 Vac	All	45–60	—	—
120V or 240 Vac capacitor trip	All	—	26–41	26–38
Optional—undervoltage trip release 48V, 125V, 250Vdc	All	—	30–45	30–45

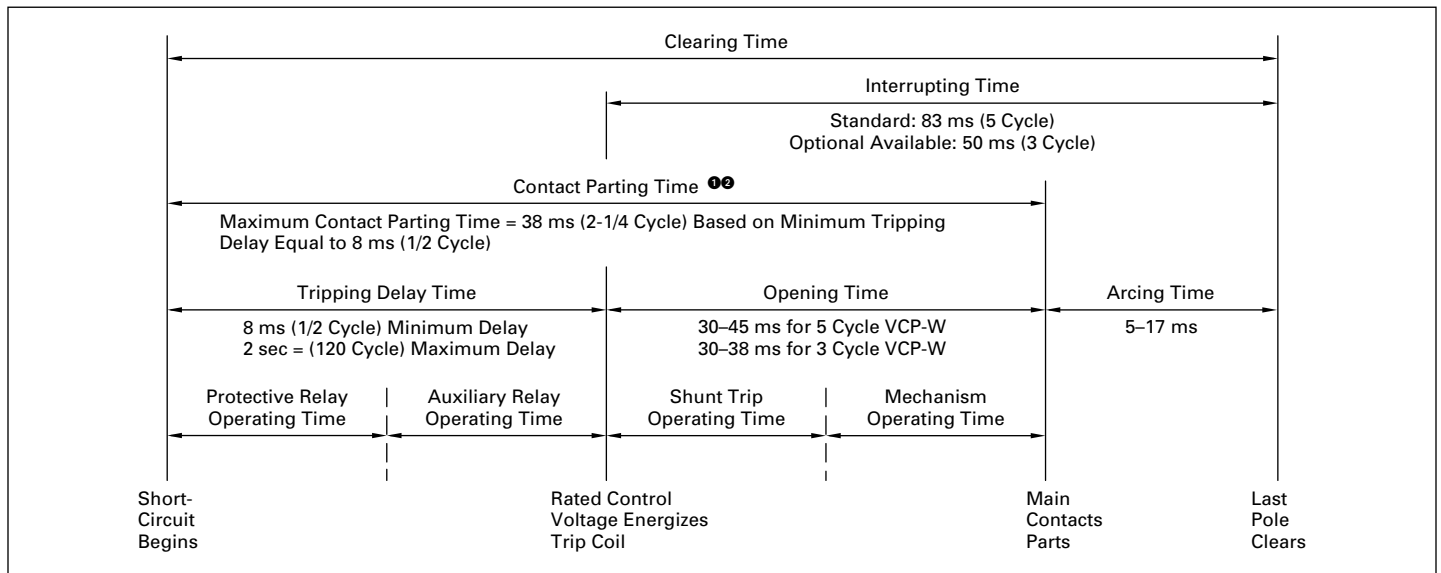

Figure 5.6-2. Sequence of Events and Circuit Breaker Operating Times

- ① Times shown are based on 60 Hz.
- ② % dc component capability (and asymmetry factor S) depend on the minimum contact parting time.
The % dc component capability is M 50% (S factor M 1.2) for all VCP-W circuit breakers.

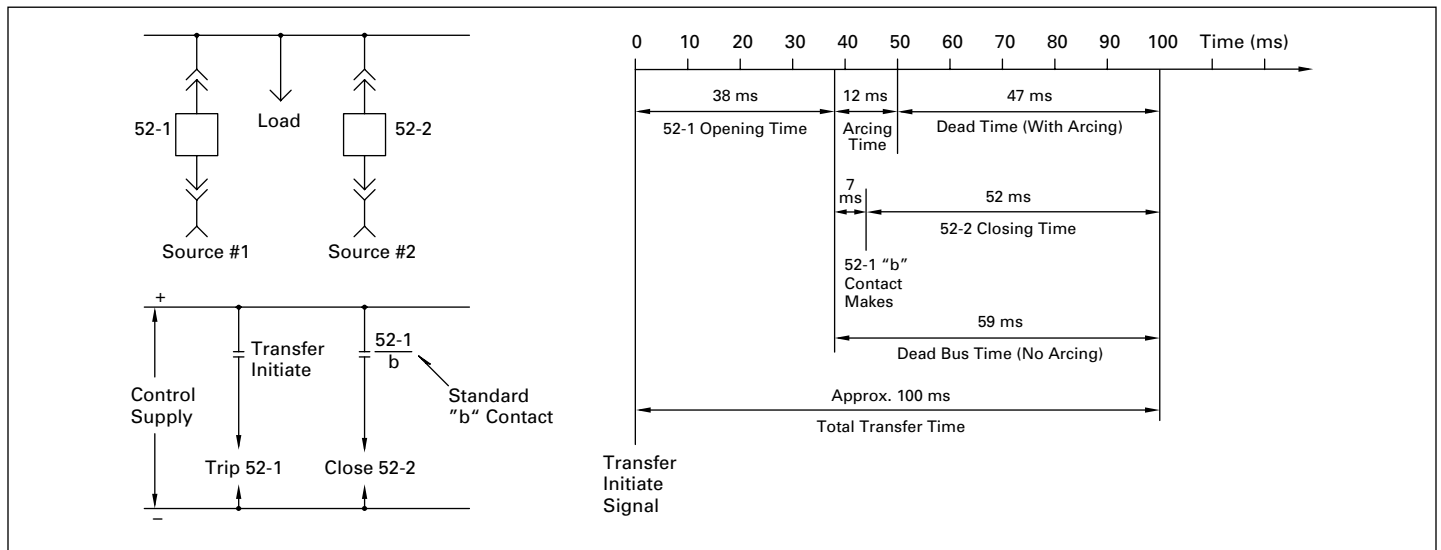

Figure 5.6-3. Typical Transfer Times—Fast Sequential Transfer

- ③ Times shown are based on 60 Hz.

Protection Relays and Metering

A full scope of protective relays designed to meet all application requirements is available to provide the utmost in system and component protection.

Instrument Transformers

Instrument transformers are used to protect personnel and secondary devices from high voltage, and permit use of reasonable insulation levels for relays, meters and instruments. The secondaries of standard instrument transformers are rated at 5 A and/or 120 V, 60 Hz.

Voltage Transformers

Selection of the ratio for voltage transformers is seldom a question since the primary rating should be equal to or higher than the system line-to-line voltage. The number of potential transformers per set and their connection is determined by the type of system and the relaying and metering required.

When two VTs are used, they are typically connected L-L, and provide phase-to-phase voltages, (Vab, Vbc, Vca) for metering and relaying.

When three VTs are used, they are connected line-to-ground, and provide phase-to-phase (Vab, Vbc, Vca), as well as phase-to-ground (Va, Vb, Vc) voltages for metering and relaying.

If metering or relaying application requires phase-to-ground voltages, use three VTs, each connected L-G. If not, use of two VTs connected L-L is sufficient.

For ground detection, three VTs connected in Line-to-ground/broken-delta are used.

A single VT, when used, can be connected line-to-line (it will provide line-to-line output, for example Vab or Vbc or Vca), or line-to-ground (it will provide line-to-ground output, for example Va or Vb or Vc). Generally, a single VT is used to derive voltage signal for synchronizing or Overvoltage/Undervoltage function.

Current Transformers

The current transformer ratio is generally selected so that the maximum load current will read about 70% full scale on a standard 5 A coil ammeter. Therefore, the current transformer primary rating should be 140–150% of the maximum load current.

Maximum system fault current can sometimes influence the current transformer ratio selection because the connected secondary devices have published one-second ratings.

The zero-sequence current transformer is used for sensitive ground fault relaying or self-balancing primary current type machine differential protection.

The zero-sequence current transformer is available with a nominal ratio of 50/5 or 100/5 and available opening size for power cables of 7.25 inches (184.2 mm). Special zero-sequence transformers with larger windows are also available.

The minimum number of current transformers for circuit relaying and instruments is three current transformers, one for each phase or two-phase connected current transformers and one zero-sequence current transformer. Separate sets of current transformers are required for differential relays.

The minimum pickup of a ground relay in the residual of three-phase connected current transformers is primarily determined by the current transformer ratio. The relay pickup can be reduced by adding one residual connected auxiliary current transformer. This connection is very desirable on main incoming and tie circuits of low resistance grounded circuits.

Standard accuracy current transformers are normally more than adequate for most standard applications of micro-processor-based protective relays and meters. See **Table 5.6-11** for CT accuracy information.

Table 5.6-9. Standard Voltage Transformer Ratio Information

Rating-Volts	2400	4200	4800	7200	8400	10800	12000	14400	15600	18000	21000	24000	27000	36000
Ratio	20-1	35-1	40-1	60-1	70-1	90-1	100-1	120-1	130-1	150-1	175-1	200-1	225-1	300-1

Table 5.6-10. Standard Voltage Transformer, 60 Hz Accuracy Information

Switchgear		Voltage Transformer—ANSI Accuracy												
kV Class	kV BIL	Maximum Number Per Set and Connection	Standard Ratios	Burdens at 120Volts				Burdens at 69.3Volts				Thermal Rating 55°C Connection	Volt-Ampere	
				W, X, Y	Z	M	ZZ	W, X	Y	M	Z			
38	170	2LL or 3LG	175, 300	0.3	0.3	0.3	0.3	0.3	0.3	0.3	0.3	0.3	LL LG LG ①	1000 550 1000

① For solidly grounded system only.

Note: LL = Line-to-line connection. LG = Line-to-ground connection.

Table 5.6-11. Current Transformers, 55 °C Ambient

CT Ratio (MR = Multi-Ratio)	Metering Accuracy Classification			Relaying Accuracy Classification		
	At 60 Hz Standard Burden B 0.1	At 60 Hz Standard Burden B 0.5	At 60 Hz Standard Burden B 1.8	Minimum Accuracy Required per IEEE C37.20.2	Standard Accuracy Supplied in VCP-W Switchgear	Optional High Accuracy Available in VCP-W Switchgear
50:5 75:5 100:5	1.2 1.2 1.2	— 2.4 2.4	— — —	C10 C10 C10	— C10 C10	C10 C20 C20
150:5 200:5 250:5	0.6 0.6 0.6	2.4 2.4 2.4	— — —	C20 C20 ②	C20 C20 C20	C50 C50 C50
300:5 400:5 500:5	0.6 0.3 0.3	2.4 1.2 0.3	2.4 2.4 2.4	C20 C50 ②	C20 C50 C50	C100 C100 C100
600:5 800:5 1000:5	0.3 0.3 0.3	0.3 0.3 0.3	2.4 1.2 0.3	C50 C50 ②	C100 C100 C100	C200 C200 C200
1200:5 1500:5 2000:5	0.3 0.3 0.3	0.3 0.3 0.3	0.3 0.3 0.3	C100 C100 C100	C200 C200 C200	C400 C400 C400
2500:5 3000:5 4000:5	0.3 0.3 0.3	0.3 0.3 0.3	0.3 0.3 0.3	② C100 C100	C200 C200 C200	C400 C400 C400
600:5 MR 1200:5 MR 2000:5 MR 3000:5 MR	0.3 0.3 0.3 0.3	0.3 0.3 0.3 0.3	2.4 0.3 0.3 0.3	② ② ② ②	C100 C200 C200 C200	C200 C400 C400 C400
50:5 zero sequence 100:5 zero sequence	— —	— —	— —	— —	C10 C20	— —

② Not listed in C37.20.2.

Note: Maximum number of CTs— Two sets of standard accuracy or one set of high accuracy CTs can be installed in the breaker compartment on each side of the circuit breaker.

Dummy Element

Dummy element is a drawout element with primary disconnects similar to a drawout circuit breaker, but consists of solid copper conductors in place of vacuum interrupters, and is designed for manual racking. It is typically used as drawout disconnect link in the primary system for circuit isolation or bypass. The device is insulated to suit the voltage rating of the switchgear and will carry required levels of short-circuit current, but it is not rated for any current interruption. It must be key interlocked with all source devices such that it can only be inserted into or removed from its connected position only after the primary circuit in which it is to be applied is completely de-energized.

Before using a dummy element, it is recommended that each user develop detailed operating procedure consistent with safe operating practices. Only qualified personnel should be authorized to use the dummy element.

Integral Motorized Remote Racking Option (VC-W MR2)

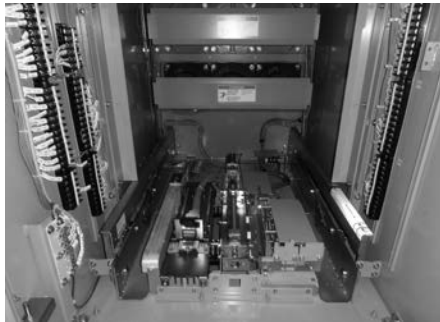

Breaker Levering Pan Assembly with Test Position – VC-W MR2 Integral Racking Device

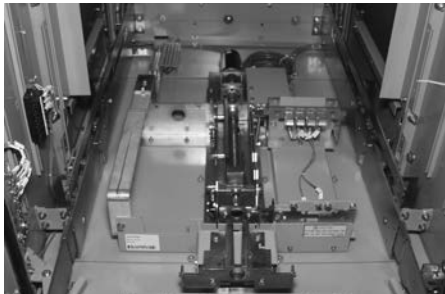

Type VC-W Arc-Resistant Switchgear Auxiliary Drawer with Type MR2 Integral Racking



Type VC-W Standard Switchgear Auxiliary Drawer with Type MR2 Integral Racking



MR2 Hand-Held Pendant

VC-W MR2 is an optional motorized racking device accessory installed inside a circuit breaker or auxiliary compartment. It is available for application in circuit breaker compartments of 5/15/27/38 kV Type VC-W arc and non-arc, and 5 kV VC-W ND metal-clad switchgear. It is also available for application in auxiliary compartments of 5/15 kV Type VC-W arc-resistant and standard switchgear. This optional accessory allows a user to safely move a circuit breaker between Connected, Test and Disconnected positions and auxiliary drawer (VT, CPT, primary fuse) between Connected and Disconnected positions within their respective compartments from a safe distance away from the switchgear. The MR2 controller also allows a user to electrically open and close the circuit breaker from a safe distance away from the switchgear. For switchgear designs/ratings not included above, contact Eaton for availability of MR2 accessory.

A microprocessor-based controller card, located below the drive motor, interfaces with an external hand-held pendant (standard), discrete external I/O (optional) or external Modbus communication (optional) and controls the breaker/auxiliary drawer movement via the drive motor. The system is also designed such that it allows manual racking of the breaker/auxiliary using the levering crank accessory if needed. The VC-W MR2 controller interface is shown in **Figure 5.6-4**. The crank safety switch disables the motor whenever a breaker/auxiliary is being manually racked in or out. The connect, test and disconnect limit switches provide breaker/auxiliary position inputs to the controller card. In addition to the standard permissive switch, two terminals are provided for connection of the customer's external interlocking/permissive contact(s). Note that a single-phase 120 Vac control supply is required for proper operation of the VC-W MR2 controller and the drive motor.

When VC-W MR2 integral racking is supplied, its controller card is wired to the CAT 6 jack installed in the associated breaker/auxiliary compartment door, and each switchgear lineup is shipped with one hand-held pendant with 30 feet of CAT 6 cable (lengths up to 100 ft available). The pendant interfaces with the MR2 controller card via the CAT 6 cable through a CAT 6 jack located on the breaker/auxiliary compartment door. It allows the operator to move away from the switchgear up to 30 feet. The pendant includes Enable pushbutton for additional security. It must be pressed in order to activate the pendant functions. By pressing Enable pushbutton and an appropriate function pushbutton together momentarily, the operator can rack the breaker between Connected, Test and Disconnected positions or open or close the breaker or rack the auxiliary drawer between Connected and Disconnected positions. Breaker or auxiliary drawer positions (Connect, Test, Disconnect) and breaker opened/closed status are indicated by appropriate LED lights on the pendant. A blinking light indicates that the breaker/auxiliary is in motion through the selected position.

A solid (non-blinking) light indicates that the breaker/auxiliary has reached and stopped in the selected position. In case normal operation fails, the appropriate error code is displayed in a separate two-character LED display window on the pendant. A list of various error codes and their descriptions along with suggested corrective actions are printed on the back side of the pendant. Examples of error states: motor overcurrent, motor overtemperature, motor timed out, breaker position unknown, open permissive, communication error and no breaker/auxiliary.

In addition to pendant, three optional I/O interfaces can be supplied as follows:

1. I/O interface to allow racking of breaker (connect, test, disconnect) or auxiliary drawer (connect, disconnect) by external hardwired dry contacts and 24 Vdc output for corresponding remote position indicating LEDs.
2. I/O board that provided dry contacts for remote indication of breaker (connect, intermediate, test, disconnect)/auxiliary drawer (connect, test) position within its compartment.
3. I/O interface to allow breaker open/close functions via external hardwired dry contacts and 24 Vdc output for corresponding remote open/close status LEDs.

The remote LED lights are not included with MR2. If the customer needs to operate the MR2 with the hand-held pendant, the pendant becomes the master and will override the customer's remote control signals.

The VC-W MR2 controller is also equipped with terminal blocks to allow the customer to interface with the controller via their SCADA system using a Modbus interface. Please note that only one of the two options, discrete I/O interface or Modbus interface, can be used, but not both.

Figure 5.6-5 shows an illustration of a typical Modbus control example. Additional components shown outside the MR2 controller in **Figure 5.6-5** are not included with the MR2. System-level controls can be optionally supplied by Eaton's Engineering Services & Systems. If the customer needs to operate the MR2 with the hand-held pendant, the pendant becomes the master and will override the Modbus interface. Error codes are displayed on Modbus devices when controlling the MR2 with Modbus and on the pendant when controlling with the pendant.

Technical Data

Control Supply Ratings

- Nominal control voltage—120 Vac, 50 or 60 Hz, single-phase
- Control voltage range—100 to 140 Vac, 50 or 60 Hz
- Time to travel from connect to disconnect, or disconnect to connect—50 seconds maximum
- Current draw during the travel—15 A maximum for about 3 seconds and 3.6 A for about 24 seconds
- Optional dry output contacts when included for position indications are rated for 125 Vac, 2 A
- External permissive contacts, when used, must be rated for 24 Vdc, 50 mA

Requirements for External Contacts and LEDs when Interfacing with MR2

- External contacts should be rated for minimum open circuit voltage of 24 Vdc, and be able to close and carry 5 mA at 24 Vdc
- When remote LEDs are used, use 24 Vdc rated LEDs, current up to 20 mA
- Optional dry output contacts when included for position indications are rated for 125 Vac, 2 A
- External permissive contacts, when used, must be rated for 24 Vdc, 50 mA

It is the customer's responsibility to provide single-phase 120 V, 50 or 60 Hz nominal supply for the MR2 controller. It can be derived from within the switchgear if an appropriate control power transformer is available within the switchgear.

Type VC-W MR2 motorized racking accessory has been endurance tested and guaranteed for 500 operations as required by IEEE C37.20.2.

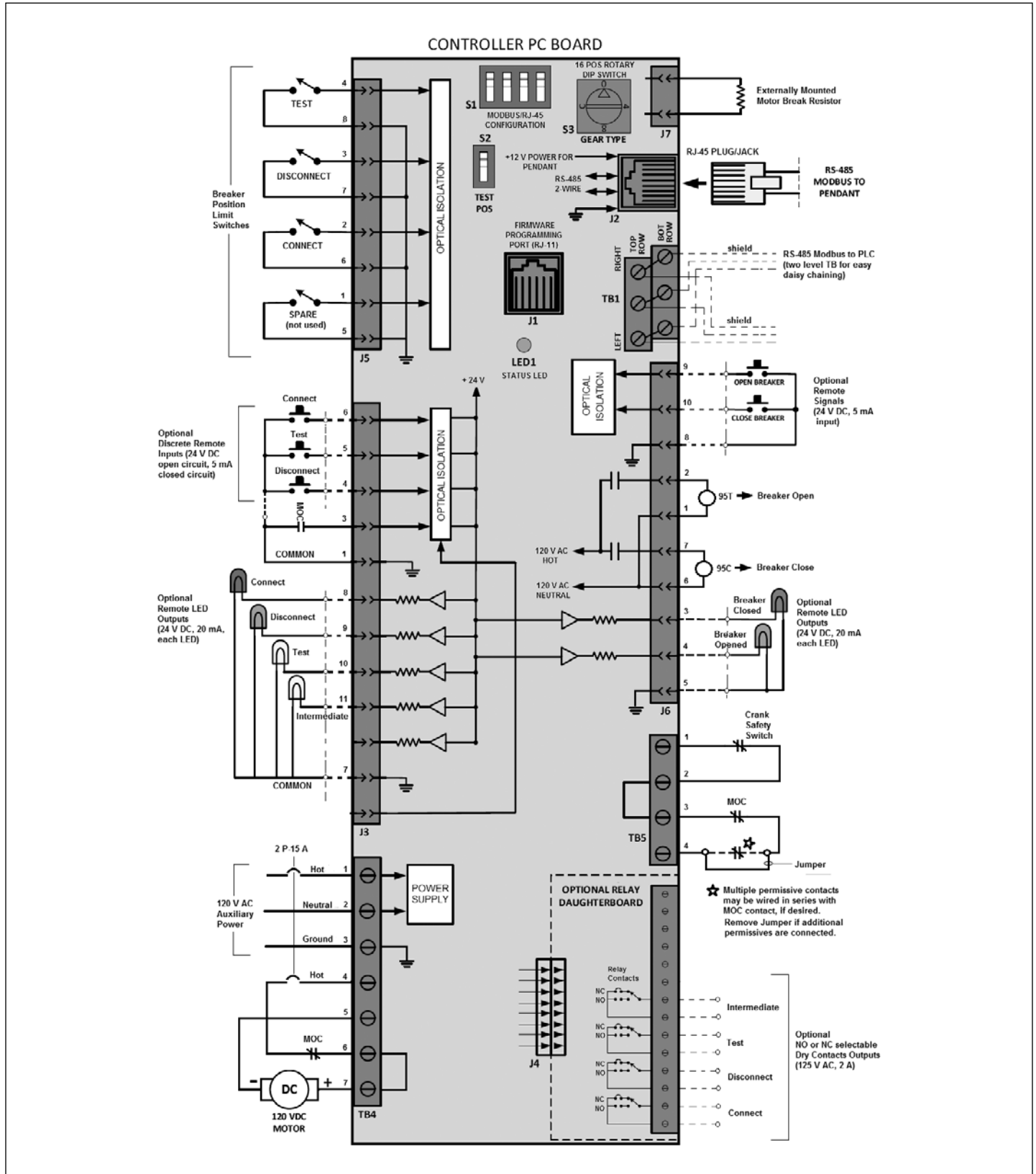

Figure 5.6-4. VC-W MR2 Controller Interface for a VCB with Distinct Test Position and Open/Close Functions

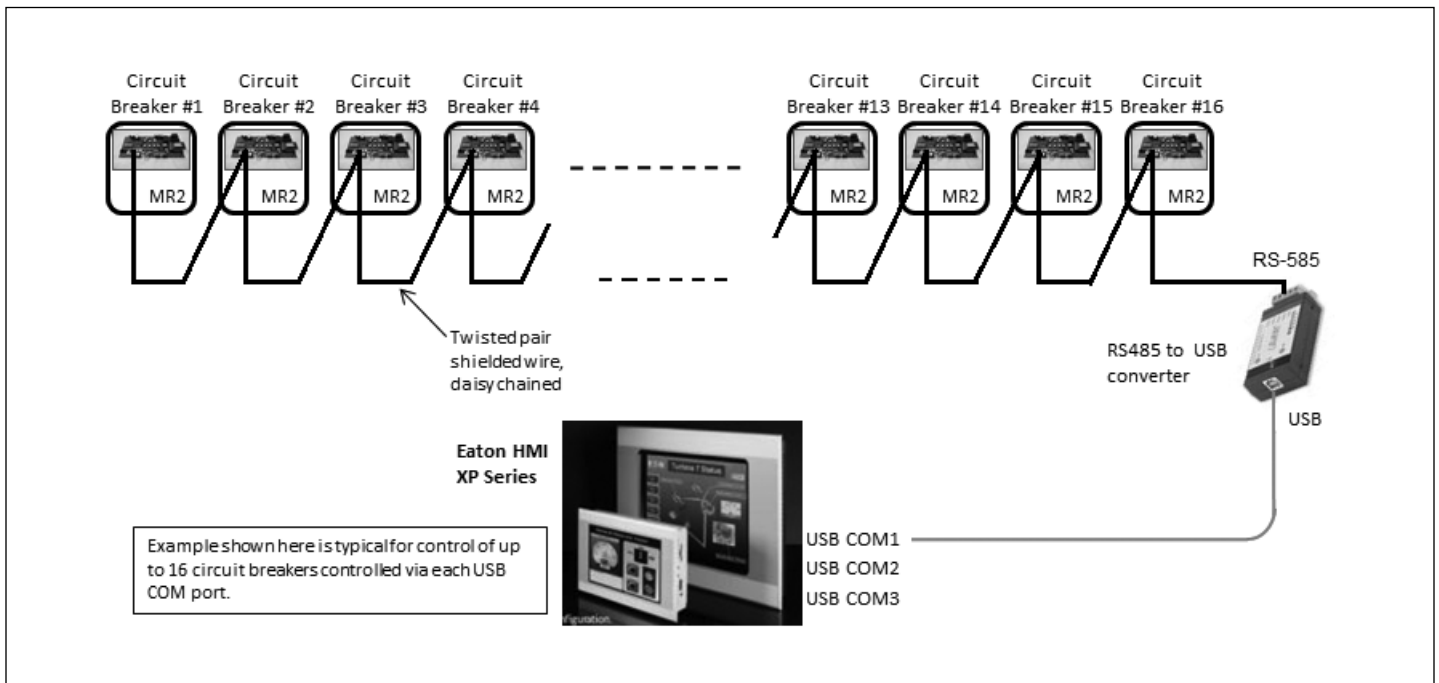

Figure 5.6-5. VC-W MR2 Typical Modbus Control Example

Accessories

Ground and Test Device

The ground and test device is a drawout element that may be inserted into a metal-clad switchgear housing in place of a circuit breaker to provide access to the primary circuits to permit the temporary connection of grounds or testing equipment to the high-voltage circuits. High potential testing of cable or phase checking of circuits are typical tests which may be performed. The devices are insulated to suit the voltage rating of the switchgear and will carry required level of short-circuit current.

Before using ground and test devices, it is recommended that each user develop detailed operating procedures consistent with safe operating practices. Only qualified personnel should be authorized to use ground and test devices.

Manual and electrical ground and test devices are available. These devices include six studs for connection to primary circuits. On the manual device, selection and grounding is accomplished by cable or bus bars connection. On electrical-type devices, grounding is accomplished by an electrically operated grounding switch.

Standard Accessories

- One test jumper
- One levering crank
- One maintenance tool
- One lifting yoke (5–27 kV)
- One sets of rails (5–27 kV)
- One turning handle (5th wheel, 38 kV)

Optional Accessories

- Transport dolly (5–27 kV), (5–15 kV arc-resistant)
- Portable lifter (5–27 kV)
- Test cabinet
- Electrical levering device (5–38 kV)
- Ramp for lower breaker (5–27 kV), (5–15 kV arc-resistant)
- Manual or electrical ground and test device
- Hi-pot tester
- Integral motorized remote racking (VC-W MR2) for circuit breaker
- Integral motorized remote racking (VC-W MR2) for auxiliary drawer

System Options

Partial Discharge Sensing and Monitoring for Switchgear



InsulGard Relay



RFCT Sensor

Partial Discharge Equipment

Partial Discharge in Switchgear

Partial discharge is a common name for various forms of electrical discharges such as corona, surface tracking, and discharges internal to the insulation. It partially bridges the insulation between the conductors. These discharges are essentially small arcs occurring in or on the surface of the insulation system when voltage stress exceeds a critical value. With time, airborne particles, contaminants and humidity lead to conditions that result in partial discharges. Partial discharges start at a low level and increase as more insulation becomes deteriorated. Examples of partial discharge in switchgear are surface tracking across bus insulation, or discharges in the air gap between the bus and a support, such as where a bus passes through an insulating window between the sections of the switchgear. If partial discharge process is not detected and corrected, it can develop into a full-scale insulation failure followed by an electrical fault. Most switchgear flashover and bus failures are a result of insulation degradation caused by various forms of partial discharges.

Sensing and Monitoring

Eaton's Type VCP-W metal-clad switchgear (2.4–38 kV) is corona-free by design. Corona emissions within the standard VacClad switchgear assemblies have been eliminated or reduced to very low levels by special fabrication and assembly techniques, such as rounding and buffing of all sharp copper edges at the joints, employing star washers for bolting metal barriers, and using specially crafted standoff insulators for primary bus supports. By making switchgear assemblies corona-free, Eaton has made its standard switchgear more reliable. However, as indicated above, with time, airborne particles, contaminants and humidity lead to conditions that cause partial discharges to develop in switchgear operating at voltages 4000 V and above. Type VC-W switchgear can be equipped with factory-installed partial discharge sensors and partial discharge sensing relay for continuous monitoring of the partial discharges under normal operation. Timely detection of insulation degradation through increasing partial discharges can identify potential problems so that corrective actions can be planned and implemented long before permanent deterioration develops. Partial discharge detection can be the foundation of an effective predictive maintenance program. Trending of partial discharge data over time allows prediction of failures, which can be corrected before catastrophic failure occurs.



InsulGard Relay (PD Monitoring)

The PD sensing and monitoring system is optional. It consists of Eaton's InsulGard™ Relay and PD sensors specifically developed for application in the switchgear to work with the relay.

Partial discharges within the switchgear compartment are detected by installation of a small donut type radio frequency current transformer (RFCT) sensor over floating stress shields of the specially designed bus or line side primary bushings. Partial discharges in customer's power cables (external discharges) are detected by installation of the RFCT around ground shields of the incoming or outgoing power cables termination.

In 27/38 kV switchgear (refer to **Figure 5.6-8**), when specified, a set of coupling capacitor sensors is installed in the rear compartment and connected to the primary circuit at every two vertical sections for measurement of discharges internal to the switchgear compartment. The sensor's output is wired to terminal blocks in control compartment for easy access for periodic field measurements. The sensor can also be connected directly to optional InsulGard relay for continuous monitoring of partial discharges. An additional RFCT sensor for each incoming and outgoing power cable circuits can be provided for measurement of external discharges.

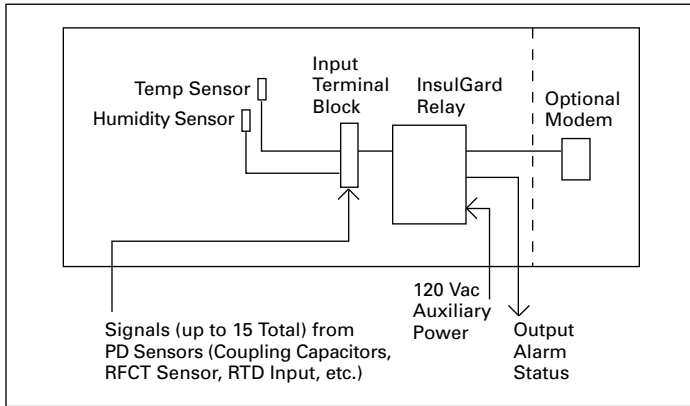
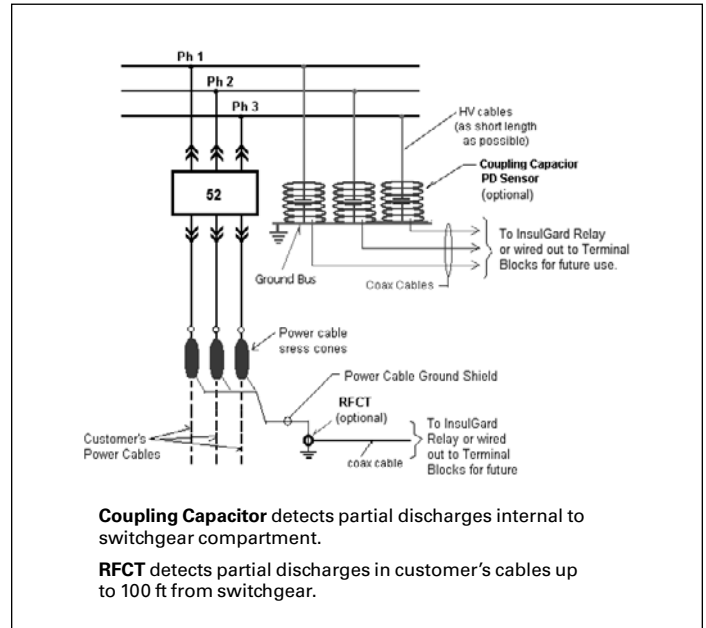

Figure 5.6-6. InsulGard Relay System



Coupling Capacitor detects partial discharges internal to switchgear compartment.

RFCT detects partial discharges in customer's cables up to 100 ft from switchgear.

Figure 5.6-8. Typical Partial Discharge Sensor Connections (27/38 kV Switchgear)

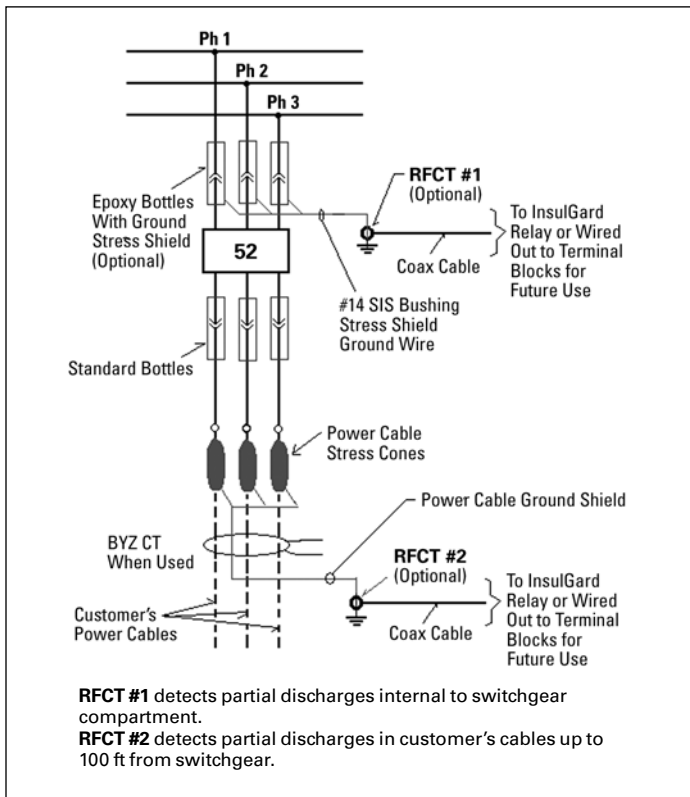

RFCT #1 detects partial discharges internal to switchgear compartment.

RFCT #2 detects partial discharges in customer's cables up to 100 ft from switchgear.

Figure 5.6-7. Typical Partial Discharge Sensor Connections (5-15 kV Switchgear)

Note: Use one set of epoxy bottles with ground stress shield on bus side (either in the top or bottom compartment) at every two vertical sections. Use standard bottles at all other locations.

Partial Discharge Sensors and Monitoring for Switchgear

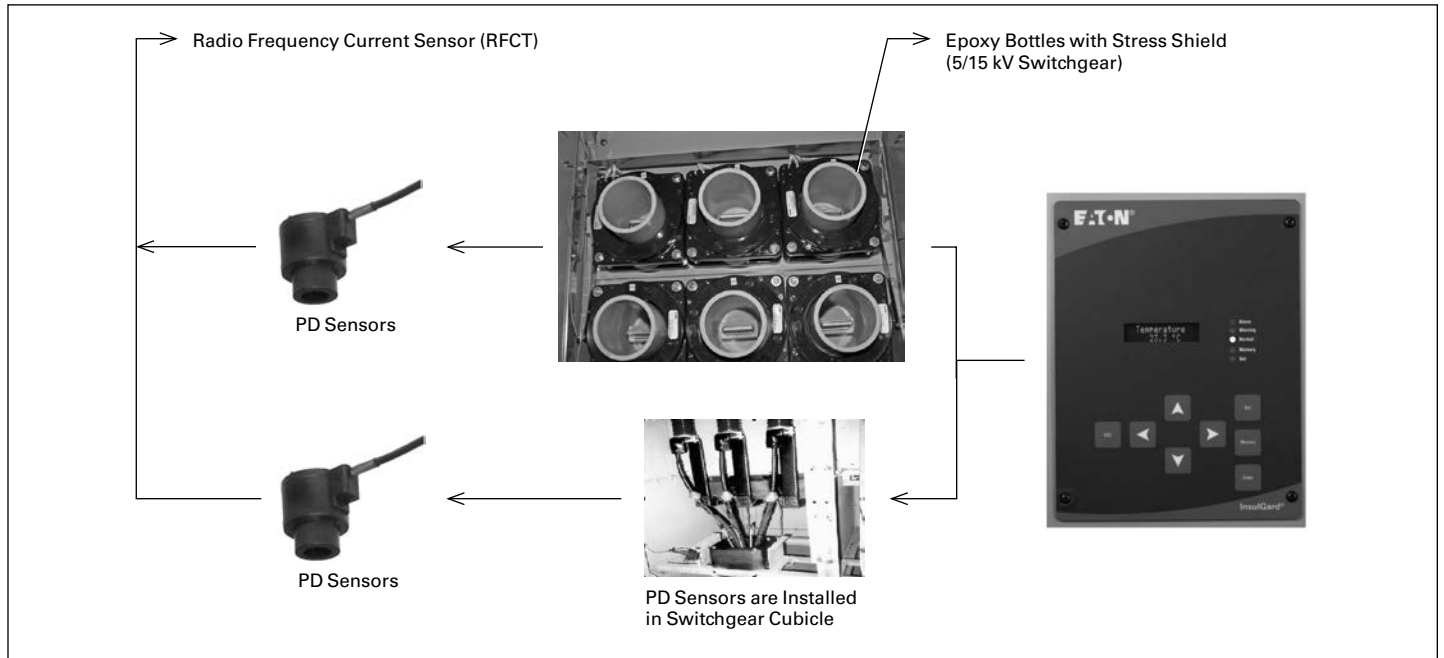

Figure 5.6-9. How the Process Works—Sensing and Data Collection

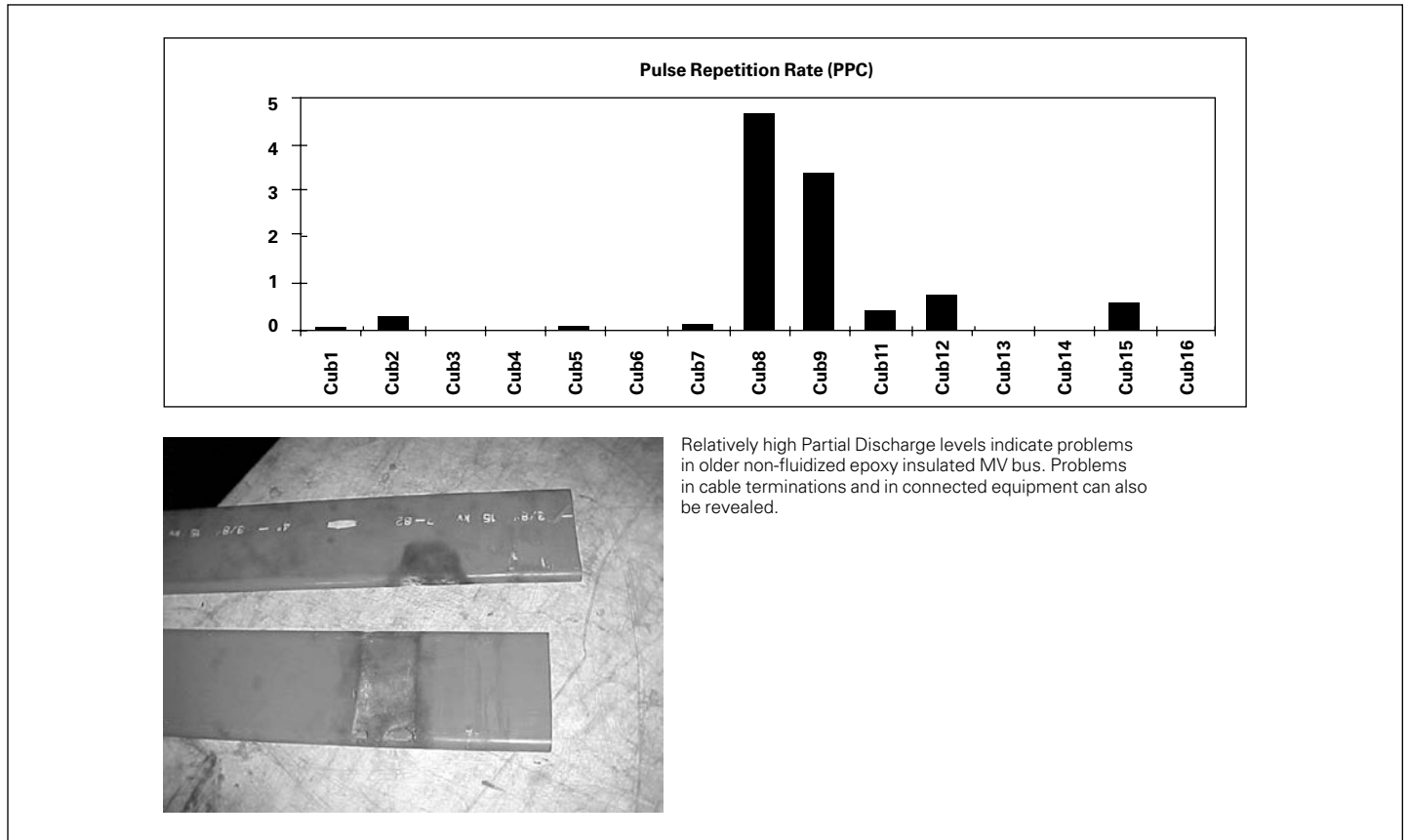

Figure 5.6-10. How the Process Works—Data Analysis and Report (Sample)

Standard

38 kV, 150 kV BIL Design

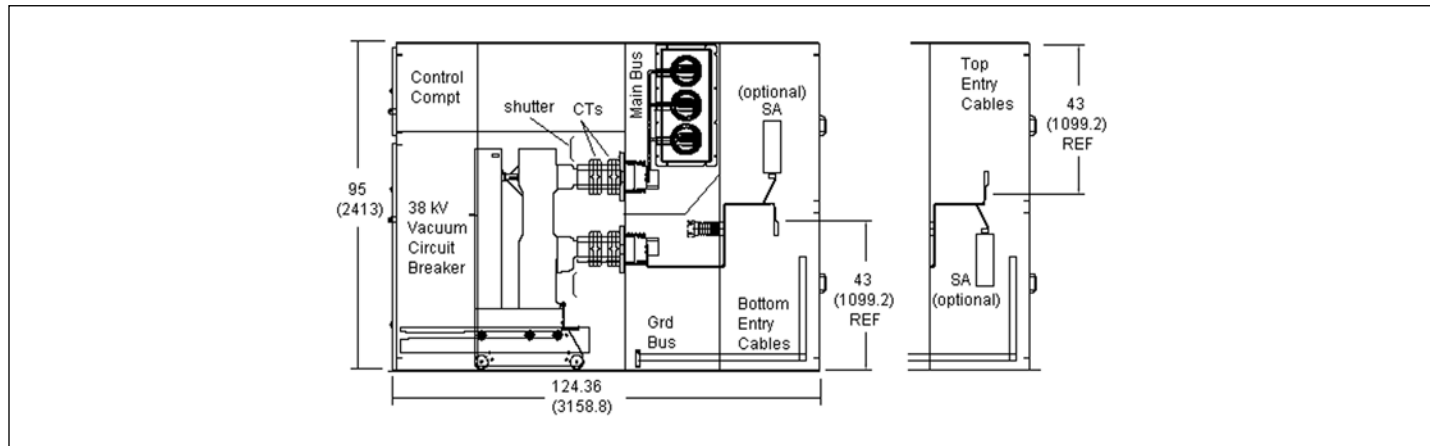

Figure 5.6-11. Indoor—Typical Breaker, Main or Feeder—Dimensions in Inches (mm)

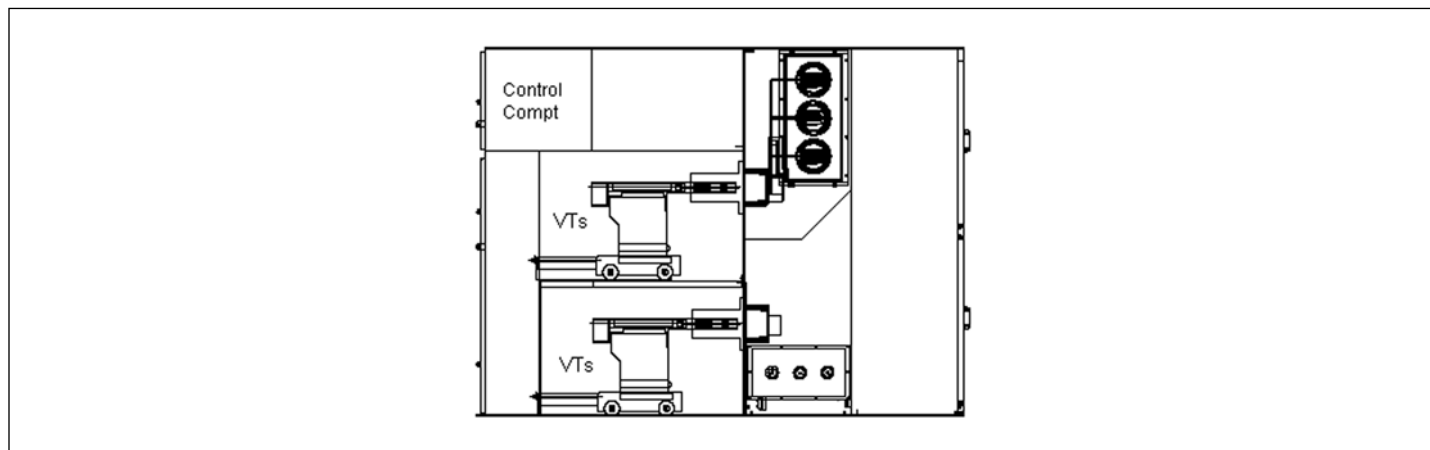

Figure 5.6-12. Indoor—Typical Auxiliary-Over-Auxiliary—Dimensions in Inches (mm)

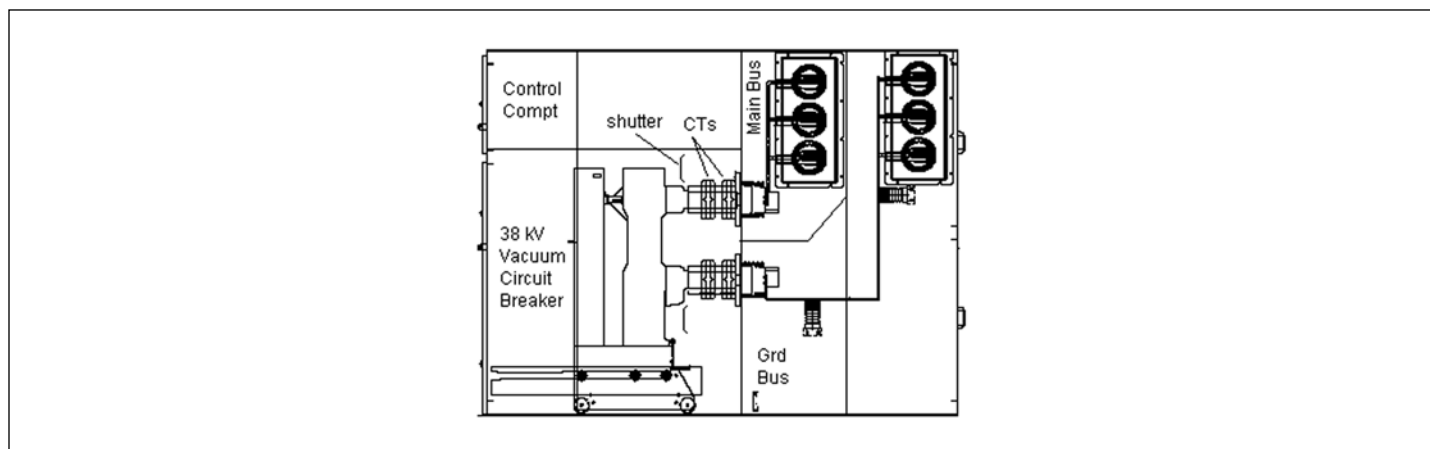

Figure 5.6-13. Indoor—Typical Bus Tie Breaker—Dimensions in Inches (mm)

Outdoor Enclosures (48-Inch and 60-Inch Wide Structures are Available)

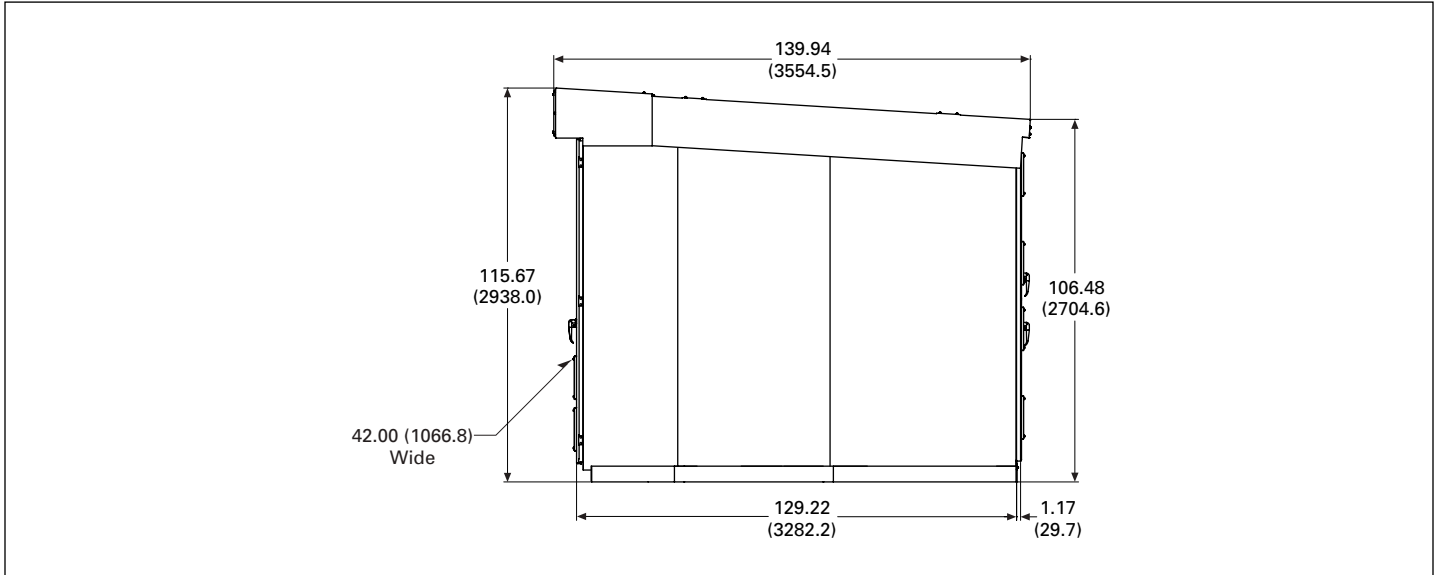

Figure 5.6-14. Outdoor Aisleless (42.00 Inches [1066.8 mm] Wide)—Dimensions in Inches (mm)

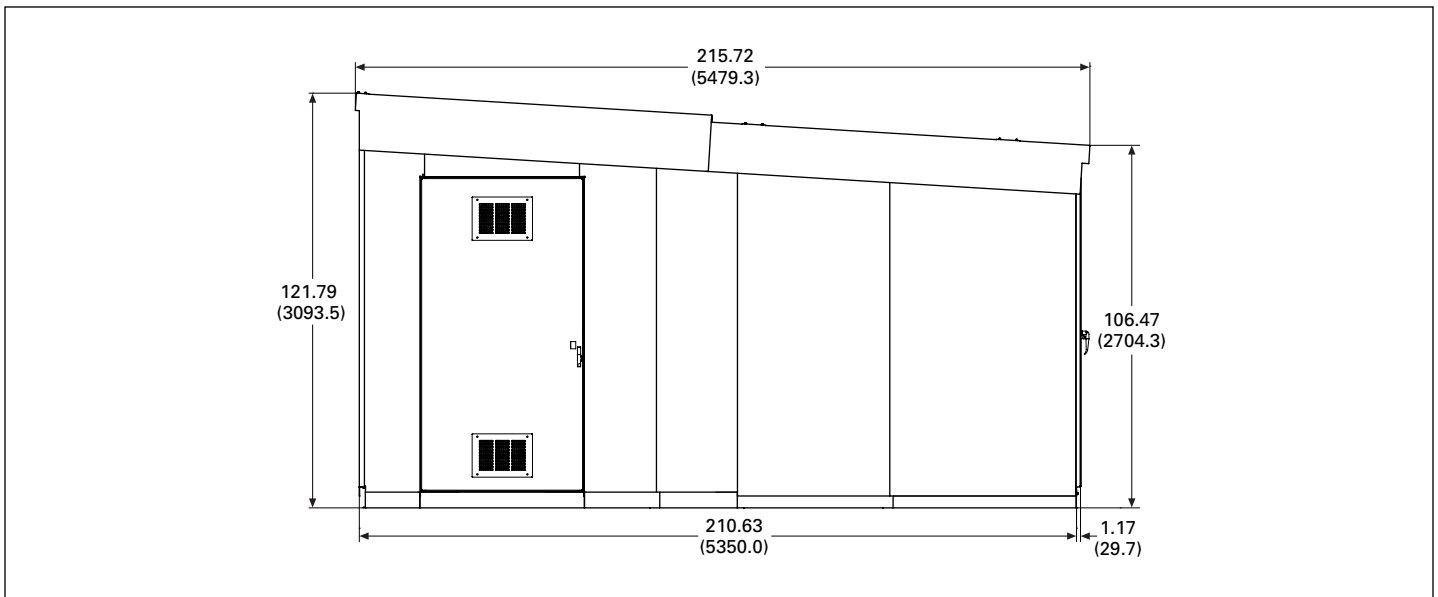
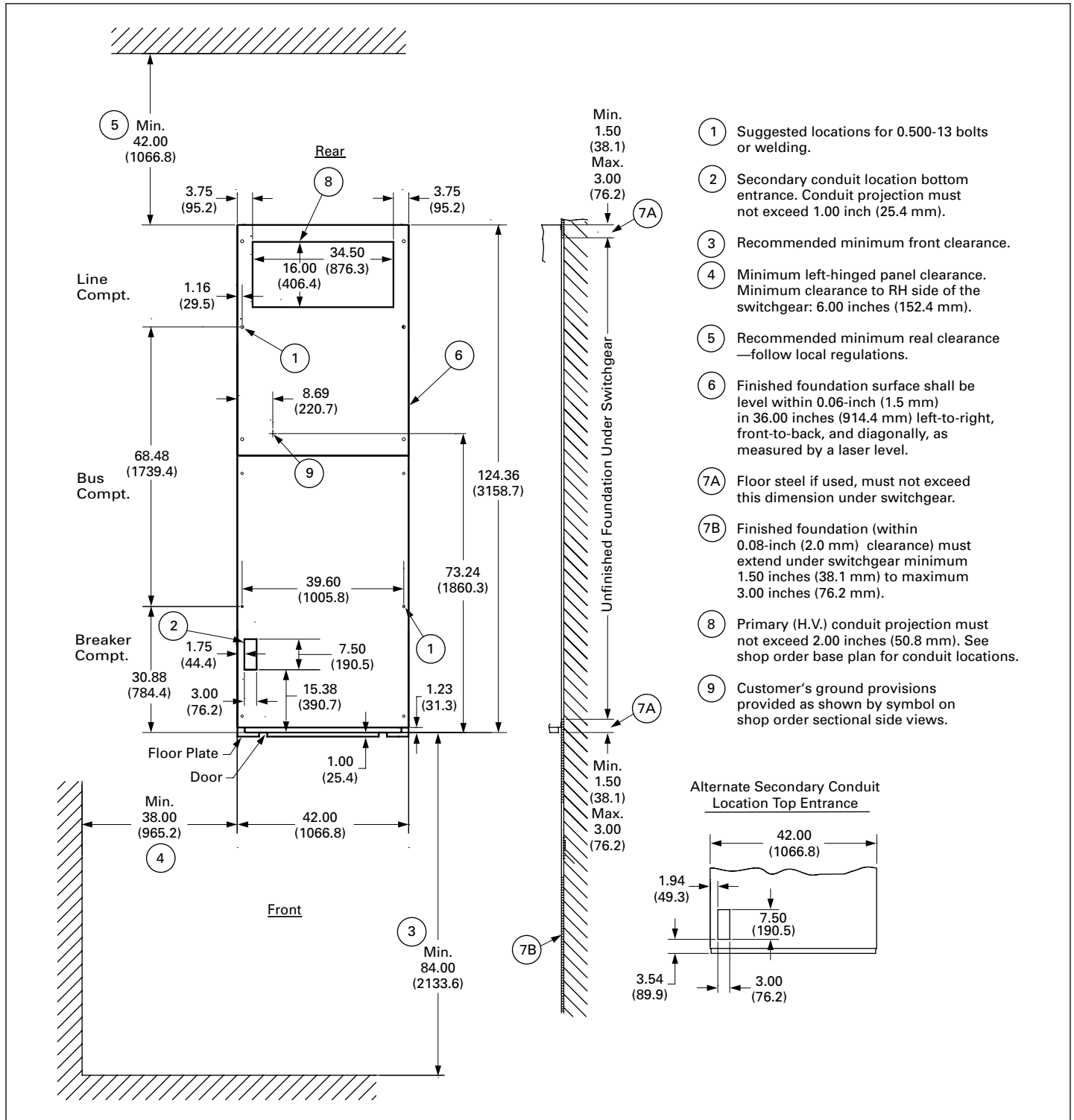

Figure 5.6-15. Outdoor Sheltered Aisle (42.00 Inches [1066.8 mm] Wide)—Dimensions in Inches (mm)

Typical Layout



- ① Suggested locations for 0.500-13 bolts or welding.
- ② Secondary conduit location bottom entrance. Conduit projection must not exceed 1.00 inch (25.4 mm).
- ③ Recommended minimum front clearance.
- ④ Minimum left-hinged panel clearance. Minimum clearance to RH side of the switchgear: 6.00 inches (152.4 mm).
- ⑤ Recommended minimum real clearance—follow local regulations.
- ⑥ Finished foundation surface shall be level within 0.06-inch (1.5 mm) in 36.00 inches (914.4 mm) left-to-right, front-to-back, and diagonally, as measured by a laser level.
- ⑦A Floor steel if used, must not exceed this dimension under switchgear.
- ⑦B Finished foundation (within 0.08-inch (2.0 mm) clearance) must extend under switchgear minimum 1.50 inches (38.1 mm) to maximum 3.00 inches (76.2 mm).
- ⑧ Primary (H.V.) conduit projection must not exceed 2.00 inches (50.8 mm). See shop order base plan for conduit locations.
- ⑨ Customer's ground provisions provided as shown by symbol on shop order sectional side views.

Alternate Secondary Conduit Location Top Entrance

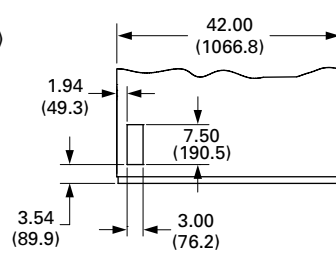

Heat Loss

Table 5.6-12. Heat Loss in Watts at Full Rating, at 60 Hz

Type of Switchgear Assembly	Breaker Rating	1200 A	2000 A	2500 A	3000 A	4000 A Fan Cooled
VCP-W	5, 15, and 27 kV	600W	1400W	—	2100W	3700W
VCP-W	38 kV	850W	1700W	2300W	3800W	—

Other Components

Each CT, standard accuracy	50W
Each CT, high accuracy	100W
Each VT	60W
CPT single-phase, 25 kVA	450W
CPT single-phase, 45 kVA	892W
Space heater—each	250W

Weights

Table 5.6-13. Assemblies (Less Breakers) ①

Type of Vertical Section	Main Bus Rating Amperes	Indoor
Breaker	1200	3100 (1409)
	2000	3200 (1455)
	2500	3355 (1525)
Auxiliary	1200	3000 (1364)
	2000	3100 (1409)
	2500	3355 (1525)

① Refer to **Table 5.6-14** for breaker weights.

Table 5.6-14. Breaker Weights in Lb (kg)

Type of Breaker	Current Rating, Amperes	
	1200	2000
380VCP-W-16, 16C	1080 (490)	1140 (518)
380VCP-W-25, 25C	1080 (490)	1140 (518)
380VCP-W-32, 32C	1080 (490)	1140 (518)
380VCP-W-21	1080 (490)	1140 (518)
380VCP-W-40, 40C	1080 (490)	1140 (518)
	1080 (490)	1140 (518)

Control Power

Table 5.6-15. VCP-W Breaker Stored Energy Mechanism Control Power Requirements

Rated Control Voltage	Spring Charging Motor			Close or Trip Amperes	UV Trip mA Maximum	Voltage Range		Indicating Light Amperes
	Inrush Amperes	Run Amperes	Average Run Time, Sec.			Close	Trip	
48Vdc	36.0	9	6	16	200	38–56	28–56	0.02
125Vdc	16.0	4	6	7	80	100–140	70–140	0.02
250Vdc	9.2	2	6	4	40	200–280	140–280	0.02
120Vac	16.0	4	6	6	—	104–127	104–127	0.02
240Vac	9.2	2	6	3	—	208–254	208–254	0.02

Table 5.6-16. Control Power Transformers—Single-Phase, 60 Hz ②

Rated Primary Voltage, Volt	Rated Secondary Voltage, Volt	kVA	kV Class
2400	240–120	5, 10, 15	5
4160	240–120	5, 10, 15	5
4800	240–120	5, 10, 15	5
7200	240–120	5, 10, 15	15
8400	240–120	5, 10, 15	15
12470	240–120	5, 10, 15	15
13200	240–120	5, 10, 15	15
13800	240–120	5, 10, 15	15
23000	240–120	5, 10, 15	27
34500	240–120	15, 25	38 ③

② Line-to-line connection only available. Refer to Eaton for other voltages and kVA ratings.

③ 150 kV BIL.

Typical Schematics

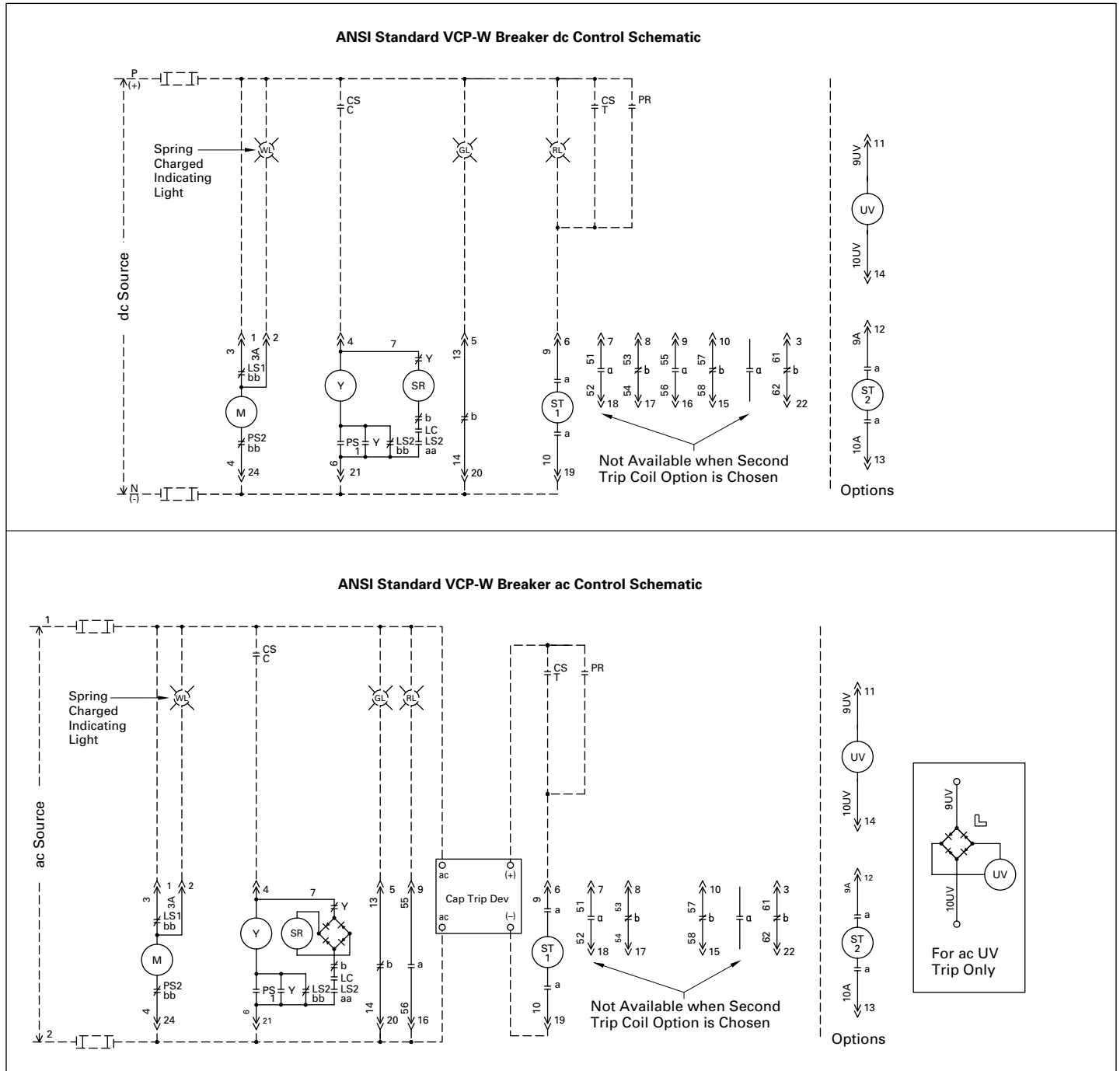

Figure 5.1-17. Typical 5/15/27 kV VCP-W “dc” and “ac” Control Schematics

Note: **CS** = Breaker Control Switch–Close
C = Breaker Control Switch–Trip
Y = Anti Pump Relay
SR = Spring Release Coil (Coil)
M = Spring Charge Motor
ST = Shunt Trip
PR = Protective Relay
Λ = Secondary Disconnect

Note: **LS1** = Closed until springs are fully charged.
LS2 = Open until springs are fully charged.
aa = Closed until springs are fully charged.
bb = Open until mechanism is reset.
LC = Open until mechanism is reset.
PS1 = Open in all except between “Test” and “Connected” positions.
PS2 = Closed in all except between “Test” and “Connected” positions.

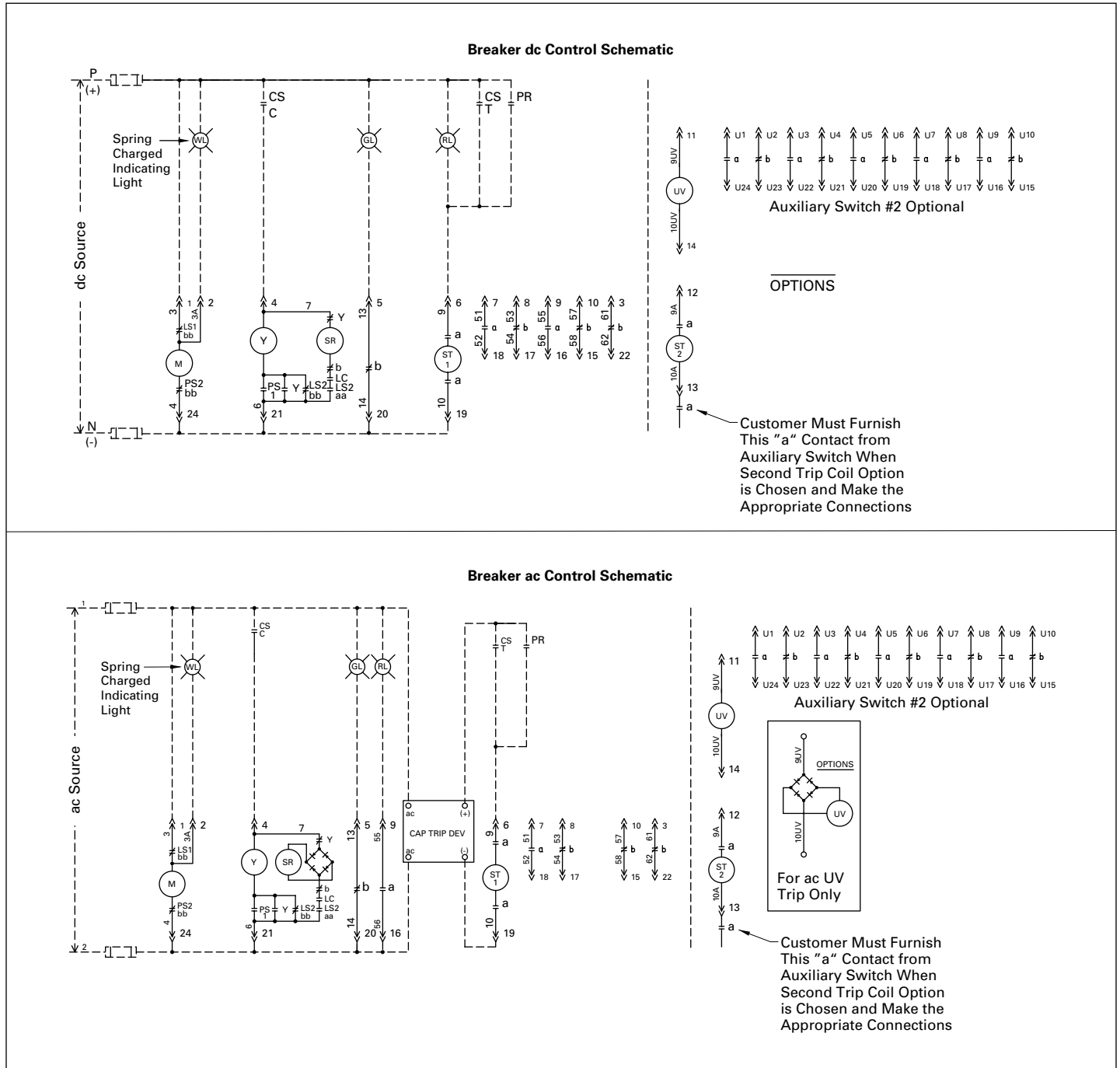

Figure 5.1-18. Typical 38 kV VCP-W "dc" and "ac" Control Schematics

Note: CS = Breaker Control Switch—Close
 C = Breaker Control Switch—Trip
 Y = Anti Pump Relay
 SR = Spring Release Coil (Coil)
 M = Spring Charge Motor
 ST = Shunt Trip
 PR = Protective Relay
 ^ = Secondary Disconnect

Note: LS1 = Closed until springs are fully charged.
 bb = Open until springs are fully charged.
 LS2 = Closed until springs are fully charged.
 bb = Open until mechanism is reset.
 PS1 = Open in all except between "Test" and "Connected" positions.
 PS2 = Closed in all except between "Test" and "Connected" positions.

Eaton
1000 Eaton Boulevard
Cleveland, OH 44122
United States
Eaton.com

© 2020 Eaton
All Rights Reserved
Printed in USA
Publication No. DG022007EN / Z23483
February 2020



Eaton is a registered trademark.
All other trademarks are property
of their respective owners.