

Medium-voltage power distribution and control systems > Motor control >

SC9000 EP variable frequency drive— medium voltage

Contents

General Description	10.4-2
General Description	10.4-2
Isolated Low-Voltage Control	10.4-4
Pre-Charge Circuit	10.4-5
Standard Ratings	10.4-6
Devices	10.4-7
Inverters	10.4-7
Isolation Switch	10.4-8
Contactors	10.4-9
Current Limiting Fuses	10.4-9
Accessories	10.4-10
Layouts and Dimensions	10.4-11
SC9000 EP Fully Integrated Frame A VFD	10.4-11
SC9000 EP Fully Integrated Frame B VFD	10.4-13
SC9000 EP Fully Integrated Frame C VFD	10.4-15
SC9000 EP Fully Integrated Frame D VFD	10.4-17
SC9000 EP Fully Integrated Frame E VFD (Single Inverter)	10.4-19
Layout Dimensions—Frame E VFD (Parallel Inverters)	10.4-21
Layout Dimensions—Integrated Ampgard Main Breaker for EP Only (Metal-Enclosed)	10.4-22
Layout Dimensions—Optional 15 kV Input Voltage Compartment	10.4-23
Layout Dimensions—SC9000 EP VFDs Output Filters	10.4-24
Layout Dimensions—SC9000 EP VFDs	10.4-25
Synchronous Transfer Control with SC9000 EP	10.4-26
Application Details	10.4-29
Typical Schematic	10.4-29



Powering Business Worldwide

General Description



SC9000 EP

SC9000 EP Variable Frequency Drive, SC9000 with Encapsulated Powerpole

Eaton's SC9000™ Encapsulated Powerpole (EP) medium-voltage adjustable frequency drive (VFD) family provides precise motor control and protection of medium-voltage equipment rated to 2400 V, 3300 V, and 4160 V nominal.

Application Description

The SC9000 EPVFD has a complete offering:

- Precise medium-voltage motor control up to 6000 hp
- Fully integrated drive including an isolation switch, main contactor, 24-pulse isolation transformer, rectifier, and inverter
- Fully compatible with Eaton's entire medium-voltage product family as integrated control gear
- Compliance with IEEE 519 (Recommended Practice and Requirements for Harmonic Control in Electric Power Systems)

Features, Benefits and Functions

Personnel safety: Positive mechanical isolating switch with visible disconnect completely grounds and isolates the VFD from the line power with a mechanically driven isolating shutter, leaving no exposed high voltage. Medium-voltage door is mechanically key locked closed with the isolation switch; low-voltage section has a separate door and is segregated from the medium-voltage section

Ease of installation: Current limiting fuse, contactor, inverter, and isolation switch assemblies can be easily removed from the enclosure. Line and load terminals are completely accessible from the front.

Ease of maintenance: All components are front accessible to aid routine inspection and/or part replacement, reducing downtime and operational expense. The low Mean Time to Repair (MTTR) equates to time and cost savings.

Smallest industry footprint: The SC9000 EP's specialized design and high density packaging make it one of the smallest footprints per hp in the industry as a fully integrated drive. This size benefit ensures installations in space limited electrical rooms, eliminates the need for additional cable and conduit installations, and in some cases, eliminates the need for additional feeders required by our competitors.

Safety in mind: Mechanical (key) doors interlocked with main disconnect. Bus discharge resistors (dc) reduce capacitors to 50 Vdc in 5 minutes or less.

Auxiliary power: Auxiliary power internally derived for control and cooling power.

Designed, built and tested with reliability in mind: Designed for reliability with serviceability in mind, Eaton's encapsulated powerpole design sets the industry standard. The innovative design utilizes conformal coating on control boards and mechanical barriers to prevent damage to adjacent components in the event of a fault. Three-level neutral point clamped (NPC) inverter topology reduces part count, improves reliability, and contributes to the SC9000 EPVFD's low lifecycle costs. Assembled and stored in a cleanroom, inverter Mean Time to Failure (MTTF) is 12.7 years. All active components are burned in and tested at a rated load for functionality up to 8 hours in a temperature controlled test bay (up to 50 °C).

Easy Ampgard integration: The SC9000 EPVFD can be supplied as a stand-alone VFD or directly connected with other Ampgard products via a common bus. Known as integrated control gear, this fully integrated solution could align the VFD with a host of other motor control products such as motor starters, load break switches, and main breakers.

Protection through technology: Eaton's encapsulated roll-in/roll-out powerpole inverter reduces potential for environmental contamination of the six separate power poles mounted to the heat pipe assembly. These individually replaceable power poles provide modularity and in field serviceability as an alternative to complete inverter replacement.

Personnel Safety Features

Interlocks

Interlocking on SC9000 EP standard and arc-resistant model (VFDs) includes:

- Isolating switch mechanism locks the medium-voltage door closed when the switch is in the ON position
- Standard key interlocks on all medium-voltage doors
- When door is open, interlock prevents operating handle from being moved inadvertently to ON position
- When contactor is energized, isolating switch cannot be opened or closed

Additional Safety Features

- Provision for a padlock on the isolating switch handle in OFF position
- Shutter barrier between line terminals and isolation switch stabs is mechanically driven
- Distinctive marking on back of switch assembly appears when shutter barrier is in position and starter is completely isolated from the line
- Grounding clips provide a positive grounding of the SC9000 EP (and model) VFD and main fuses when the isolating switch is opened
- High- and low-voltage circuits are compartmentalized and isolated from each other
- The drawout isolation switch is easily removed by loosening two bolts in the back of the switch. The shutter remains in place when the switch is withdrawn
- Grounding device is provided for shorting the dc bus to ground before entering the medium-voltage

See **Page 10.4-8** for details on the Mechanical Non-Loadbreak Isolating Switch.

Standards and Certifications

UL and CSA Certification

All SC9000 EP models are designed, assembled and tested to meet all applicable standards: NEMA ICS6, NEMA ICS7, IEEE 519, IEEE 1100, UL 347A and CSA C22.2. The major components (contactor, isolating switch, fuses, transformer and inverter active devices) are UL recognized.

UL or CSA labeling of a specific VFD requires review to ensure that all requested modifications and auxiliary devices meet the appropriate standards. Refer to factory when specified.

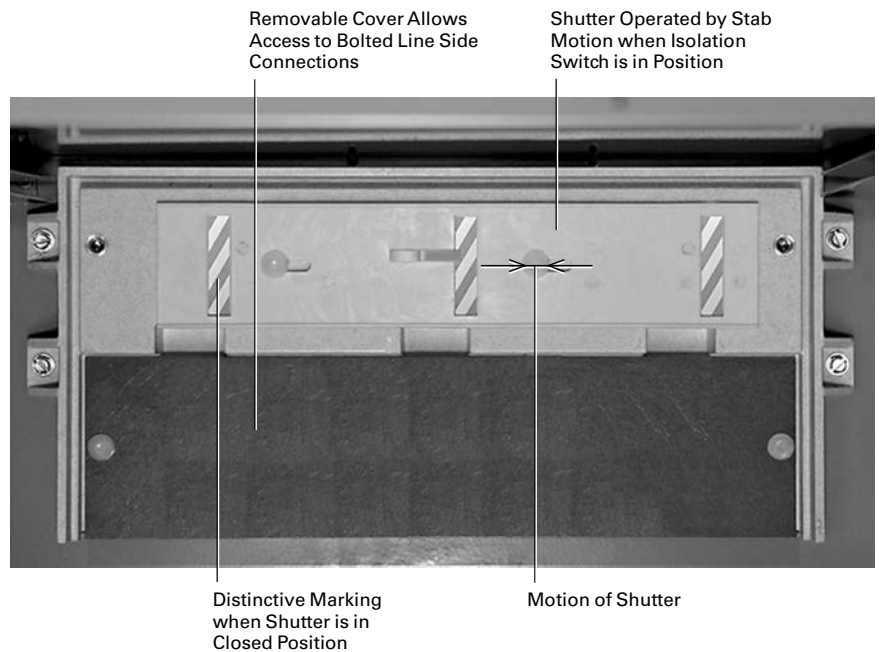
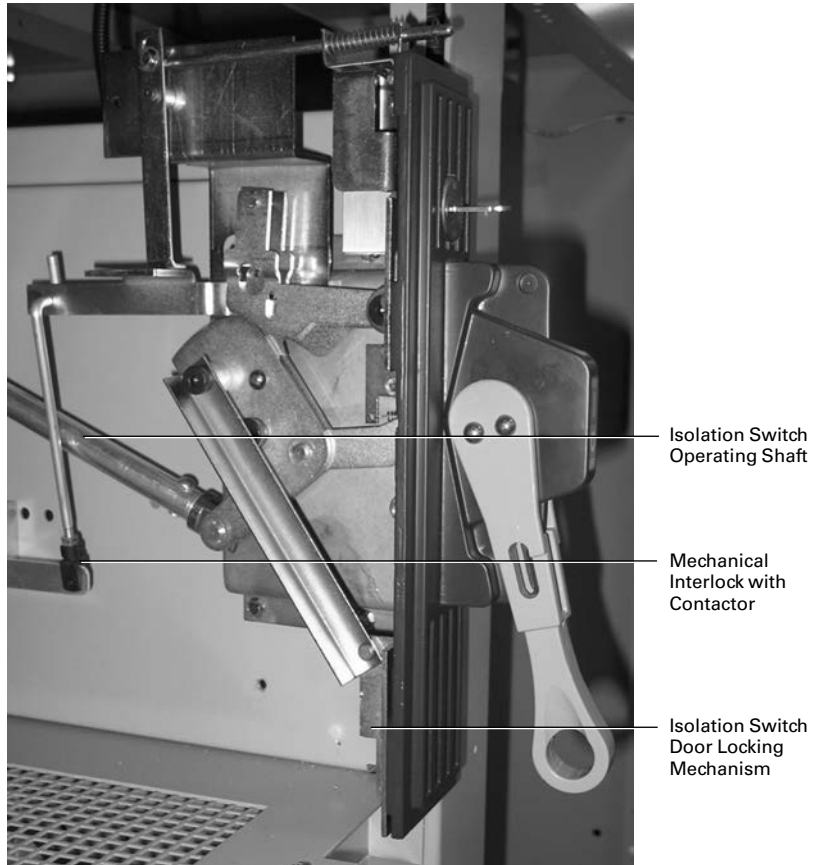

Shutter Mechanism and Finger Barrier Isolation of Incoming Line Bus (Shown with Removable Portion of Isolation Switch Removed)

Isolated Low-Voltage Control

The low-voltage door has four cutouts as standard.

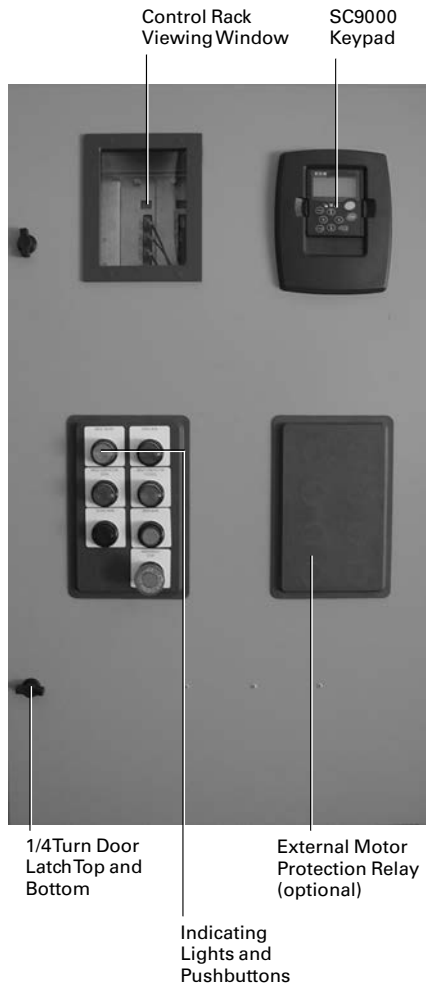

SC9000 EP VFD Low-Voltage Door Closed

The device panel and optional Eaton motor protection relays fit in the low-voltage door. The standard SC9000 EP keypad can be removed for plug-in of a laptop via a serial connection. A standard viewing window allows visual verification of the SC9000 EPVFD status. The low-voltage control panel is behind the low-voltage door and is completely isolated from the medium-voltage compartment. The medium-voltage door is locked closed and interlocked with the isolation switch.

Pre-Charge Circuit

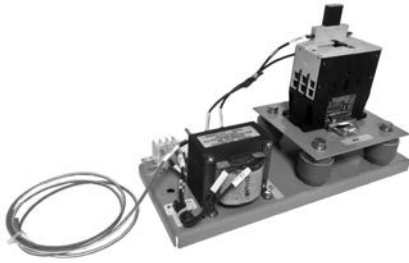

SC9000 EP Pre-Charge Circuit

The SC9000 EP utilizes two innovative pre-charging methods to protect the transformer and other sensitive components from the damaging effects of high in-rush currents.

The pre-charge circuit design uses the control power circuit for dc link capacitor charging to increase the life of affected components.

The SC9000 EP utilizes a “Soft-Mag” pre-charge system. The isolation transformer is magnetized and the DC bus capacitors are charged at the same time. An integral three-phase step-down control power transformer is tied into the secondary windings of the isolation transformer. The soft-mag impedance limits the current and magnetizes the isolation transformer from the secondary side in-phase with the line voltage. When the main medium-voltage input contactor is closed, there is zero inrush current on the line side of the VFD.

SC9000 EP Options

Integrated Control Gear Under One Main Bus Options

- Ampgard main/feeder breaker
- Incoming line section
- Load break switches
- Output contactor
- Full voltage non-reversing starter bypass
- Reduced voltage solid-state bypass
- Reduced voltage auto-transformer bypass
- Reduced voltage primary reactor bypass
- Full voltage non-reversing additional starters
- Reduced voltage solid-state additional starters
- Reduced voltage auto-transformer additional starters
- Synchronous starters
- Classic Ampgard transition

Enclosure Options

NEMA 1 Gasketed is standard and the only enclosure option at this time. If an outdoor installation is required, Eaton can supply the VFDs and other electrical equipment in a modular building called an Integrated Power Assembly.

Monitoring and Protection Options

- Powerware UPS control power backup
- Eaton Power Xpert meters
- Eaton EMR-4000 motor protection relays with RTDs
- Eaton EMR-5000 motor protection relays with RTDs
- Redundant fans with automatic switchover
- Motor RTD protective device

Standard Protection

- Electronic overload (49)
- Instantaneous overcurrent (50)
- ac time overcurrent (51)
- Underload (37)
- Current imbalance (46)
- Line/load phase loss (46)
- Line/dc bus overvoltage (59)
- Line/dc bus undervoltage (27)
- Line phase rotation (47)
- Lockout/start inhibit (86)
- Load ground fault (50N/59G)

Standard Monitoring

- Frequency reference
 - Output frequency
 - dc bus voltage
 - Motor voltage
 - Motor current
 - Motor power %
 - Total kWh
 - Run time
 - Unit temperature
- (See IB020002EN for more details)

Communications Options

- Johnson Controls N2
- ModbusTCP
- Modbus
- PROFIBUS® DP
- DeviceNet
- BACnet
- CANopen
- LonWorks®
- EtherNet/IP

Output Filters All Models

Drive output filters are recommended for longer cable lengths between the drive and motor.

Table 10.4-1. Recommended Output Filter Application

Motor Type	Motor Lead Length (ft)	
	dv/dt Filter	Sine Filter
2400V Output		
Non-inverter duty rated	>60	>175
Inverter duty rated	>150	>750
4160V Output		
Non-inverter duty rated	>120	>500
Inverter duty rated	>300	>1250

Standard Ratings

Table 10.4-2. Design Specifications

Description	NEMA	IEC
	EP	EP
Power rating	300–6000hp (150–4474 kW)	223–4474 kW
Motor type	Induction and synchronous	Induction and synchronous
Input voltage rating	2400–13800 V	2 400–15,000 V
Input voltage tolerance	+/-10% of nominal	+/-10% of nominal
Power loss ride-through	5 cycles (std.)	5 cycles (std.)
Input protection	Metal oxide varistor	Metal oxide varistor
Input frequency	50/60 Hz, +/-5%	50/60 Hz, +/-5%
Input power circuit protection	Contactors/fuses	Contractor/fuses
Input impedance device	Isolation transformer	Isolation transformer
Output voltage	0–2400 V 0–3300 V 0–4160 V	0–2 400 V 0–3 300 V 0–4 160 V
Inverter design	PWM	PWM
Inverter switch	IGBT	IGBT
Enclosure	NEMA 1, gasketed and filtered	IP20
Ambient temperature (without derating)	+32 °F to +104 °F	0 °C to +40 °C
Storage and transport temperature	-40 °F to +170 °F	-40 °C to +76 °C
Relative humidity	95% noncondensing	95% noncondensing
Altitude (without derating)	0–3300 ft	0–1000 m
Seismic	2006 IBC	2006 IBC
Standards	NEMA, cUL, UL, ANSI, IEEE	IEC
Cooling	Air-cooling advanced heat pipe technology	Air-cooling advanced heat pipe technology
Average watts loss ①	23 watts/hp	23 watts/hp
Input power factor	>0.98	>0.98
Number of inverter IGBTs	IGBTs	IGBTs
2400 V	12	12
3300 V	12	12
4160 V	12 ②	12
IGBT PIV rating	PIV	PIV
2400 V	3300 V	3300 V
3300 V	6500 V	6500 V
4160 V	6500 V	6500 V
Rectifier designs	24-pulse	24-pulse
Rectifier switch	Diode	Diode
Rectifier switch failure mode	Non-rupture, non-arc	Non-rupture, non-arc
Rectifier switch cooling	Air-cooled	Air-cooled
Output waveform to motor	Sinusoidal current/voltage	Sinusoidal current/voltage
Speed regulation	0.1% without tach feedback	0.1% without tach feedback
Output frequency range	1–120 Hz	1–120 Hz
Service duty rating	Standard	Standard
Typical efficiency	97%	97%
Flying start capability	Yes	Yes

① Reflects conservative estimate. Actual amounts may vary.

② 24 IGBTs are required for motors above 5000 hp.

Inverters

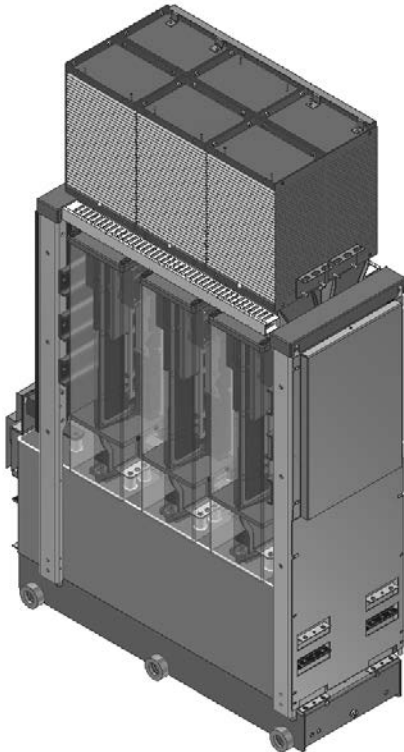

Six-Pack, Roll-In/Roll-Out Inverter (Side Sheets Not Shown). Up to 5000 hp on Single Inverter

Modular Roll-in/Roll-out Stab-in Three-Phase Inverter

The roll-in/roll-out three-phase inverter module employs an insulation and buswork system to obtain the highest power density rating in the market. Heat pipe technology is used to cool active power components in the inverter.

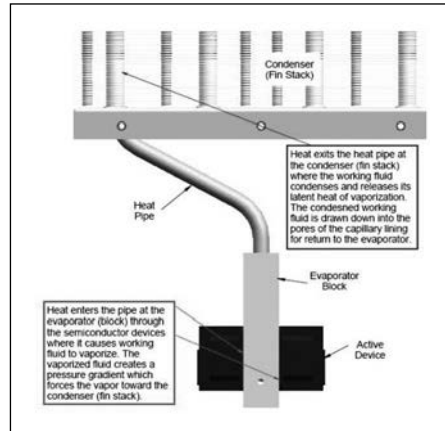

Figure 10.4-1. Heat Pipe Thermal Management System

This method of heat removal from the inverter is up to 10 times more efficient than traditional air-cooling methods, resulting in less required airflow for quieter and more efficient operation. The thermal management system has been subjected to temperatures of -50 °C to model cold weather transport without the rupture of any heat pipes. It is also important to note that thermal management performance was unaffected by the extreme cold storage.

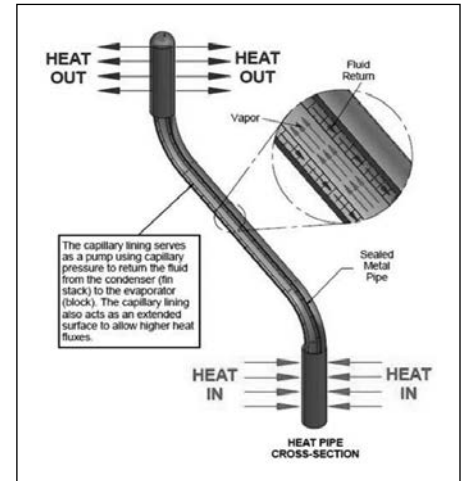

Figure 10.4-2. Heat Pipe Construction

Eaton’s cooling methodology and encapsulation of medium-voltage components produce a harsh environment inverter that protects active power devices from environmental conditions and airborne contaminants thereby eliminating potential causes of failures.

In the event of a failure, the modular roll-in/roll-out inverter design minimizes downtime. The inverter can partially withdraw from the structure for repairs without ever having to fully remove the inverter. For even faster return to service, the inverter can be fully withdrawn from the structure. A spare inverter can then be quickly reinstalled. The drive is then ready to restart the motor with minimal downtime.

Isolation Switch

Mechanical Non-Loadbreak Isolating Switch

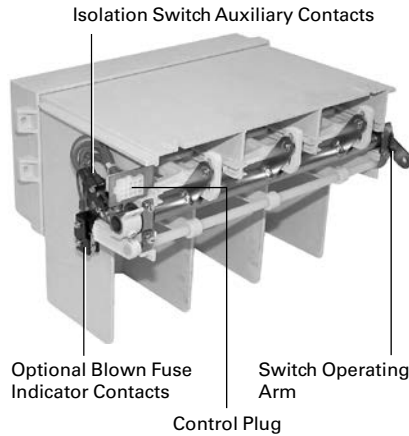

**JMT-400/800 A Isolation Switch
Front View**

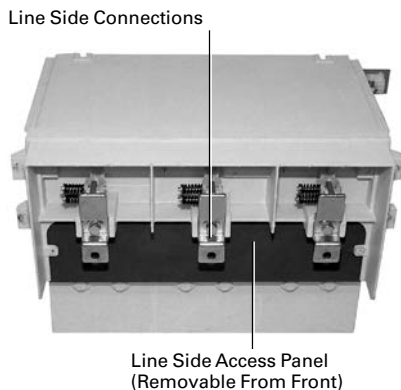

**JMT-400/800 A Isolation Switch
Rear View**

General Description

Eaton’s Type JMT-4/8 is a drawout, lightweight, three-pole, manually operated isolating switch mounted in the top of the starter enclosure. They may be easily removed by loosening two bolts in the rear of the switch. The JMT-4 is rated 400 A continuous while the JMT-8 is rated 720 A continuous. All isolation switches have a mechanical life rating of 10,000 operations.

The component-to-component circuitry concept includes the mountings for the current limiting fuses as part of the isolating switch.

Features

A positive mechanical interlock between the isolating switch handle mechanism and contactor prevents the isolating switch from being opened when the contactor is closed or from being closed if the contactor is closed.

An operating lever in the isolating switch handle mechanism is designed to shear off if the operator uses too much force in trying to open the non-loadbreak isolating switch when the contactor is closed. This feature ensures that the operator cannot open the switch with the main contactor closed, even if excessive force is used on the operating handle.

To operate the isolating switch, the operating handle is moved through a 180° vertical swing from the ON to the OFF position. In the ON position, a plunger on the back of the handle housing extends through a bracket on the rear of the starter high-voltage door, preventing the door from being opened with the switch closed. When the high-voltage door is open, a door interlock prevents the handle from being inadvertently returned to the ON position.

When the operating handle is moved from ON to OFF, copper stabs are withdrawn from incoming line fingers. As the stabs withdraw, they are visible above the top of the fuses when viewed from the front, and simultaneously grounded. As the fingers are withdrawn, a spring-driven isolating shutter moves across the back barrier to prevent front access to the line connections. As the shutter slides into position, distinctive markings appear on the back barrier, making it easier to check the position of the shutter.

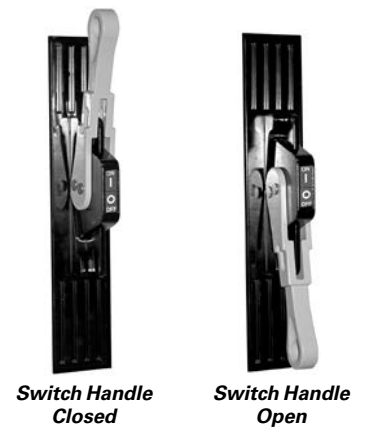

**Switch Handle
Closed**

**Switch Handle
Open**

Contactors

Type SL Vacuum Contactor Stab-in with Wheels, Fuses, and Line and Load Fingers

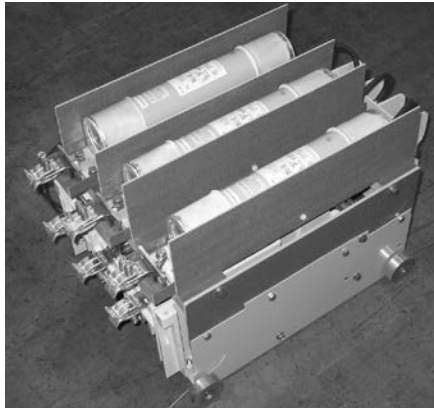

400 A Stab-In Contactor and Fuse Assembly

400 A Vacuum Contactors

The standard stab-in SL contactor is mounted on wheels and rolls into the SC9000 EP standard and arc-resistant model (VFDs) structure. Contactor line and load fingers engage cell-mounted stabs as the contactor is inserted into the SC9000 EP standard and arc-resistant model (VFDs) incoming cell. The contactor is held in position by a bolt and bracket combination. It can be easily withdrawn from the SC9000 EP standard and arc-resistant model (VFDs) incoming cell by removing the bolt holding the contactor against the bracket and disconnecting the isolation switch interlock. The contactor can be removed from the SC9000 EP standard and arc-resistant model (VFDs) after disconnecting the medium-voltage cables going to the control transformer.

800 A Vacuum Contactors

The 800 A SL Contactor is available in the SC9000 EP standard and arc-resistant model (VFDs) Frames D and E and is rated at 720 A enclosed.

The 800 A contactor is mounted on wheels and has similar features to the stab-in 400 A contactor.

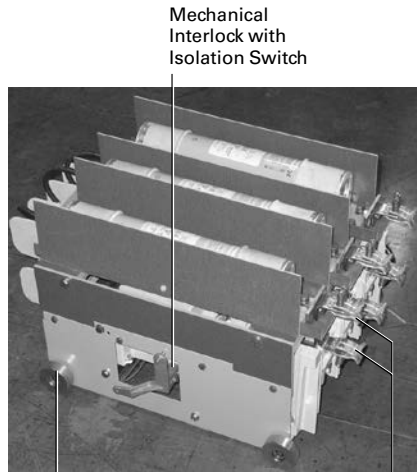

Roll-Out Wheels

Self-Aligning Contactor Line and Load Fingers

400 A Stab-In Contactor Mechanical Interlock and Fingers



800 A Stacked

Current Limiting Fuses

SC9000 EP standard and arc-resistant model (VFDs) use Eaton's Type HLE power fuses with special time/current characteristics. The fuse is coordinated with the contactor to provide maximum motor/transformer utilization and protection. The standard mounting method for power fuses is bolted onto the contactor assembly.

Interruption is accomplished without expulsion of gases, noise or moving parts. Type HLE fuses are mounted in a horizontal position. When a fault has been cleared, an indicator in the front of the fuse, normally depressed, pops up to give visible blown fuse indication.

The control circuit primary fuses are also current limiting.

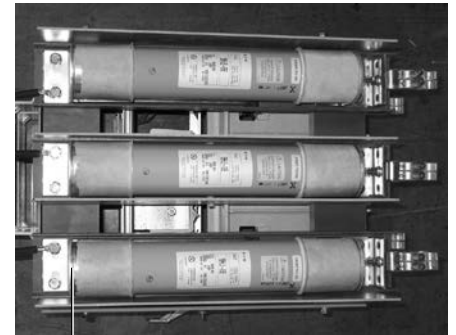

Fuse Fault Indicator

Blown Fuse Indicating Device

Accessories

Inverter Replacement System

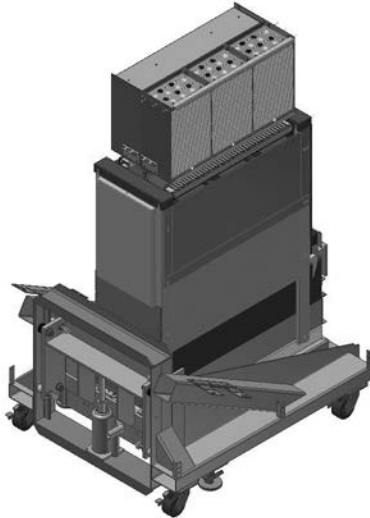

Inverter Replacement System

Optional inverter extraction tool is available for removal of inverter for maintenance or repair of inverter.

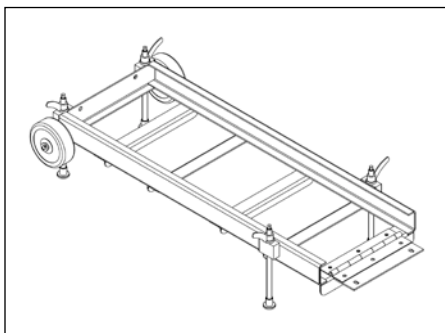

Figure 10.4-3. Optional Inverter Extraction Tool

Remote Operator

A remote operator for the starter isolation switch is an available option. The Ampgard Remote Operator (ARO) enables users to open or close the switch through the use of a pushbutton station operated up to 30 feet away from the starter. Users can mount the ARO on the front of the starter, plug it into any available 120 Vac source, then easily operate the isolation switch from outside the starter arc flash boundary.



Ampgard Remote Operator

**SC9000 EP Fully Integrated Frame A VFD
(300–1150 hp at 4160 V) (300–700 hp at 3300 V) (300–600 hp at 2400 V)**

Horsepower ratings based on 1800 RPM motors, variable torque, standard temperature and elevation.

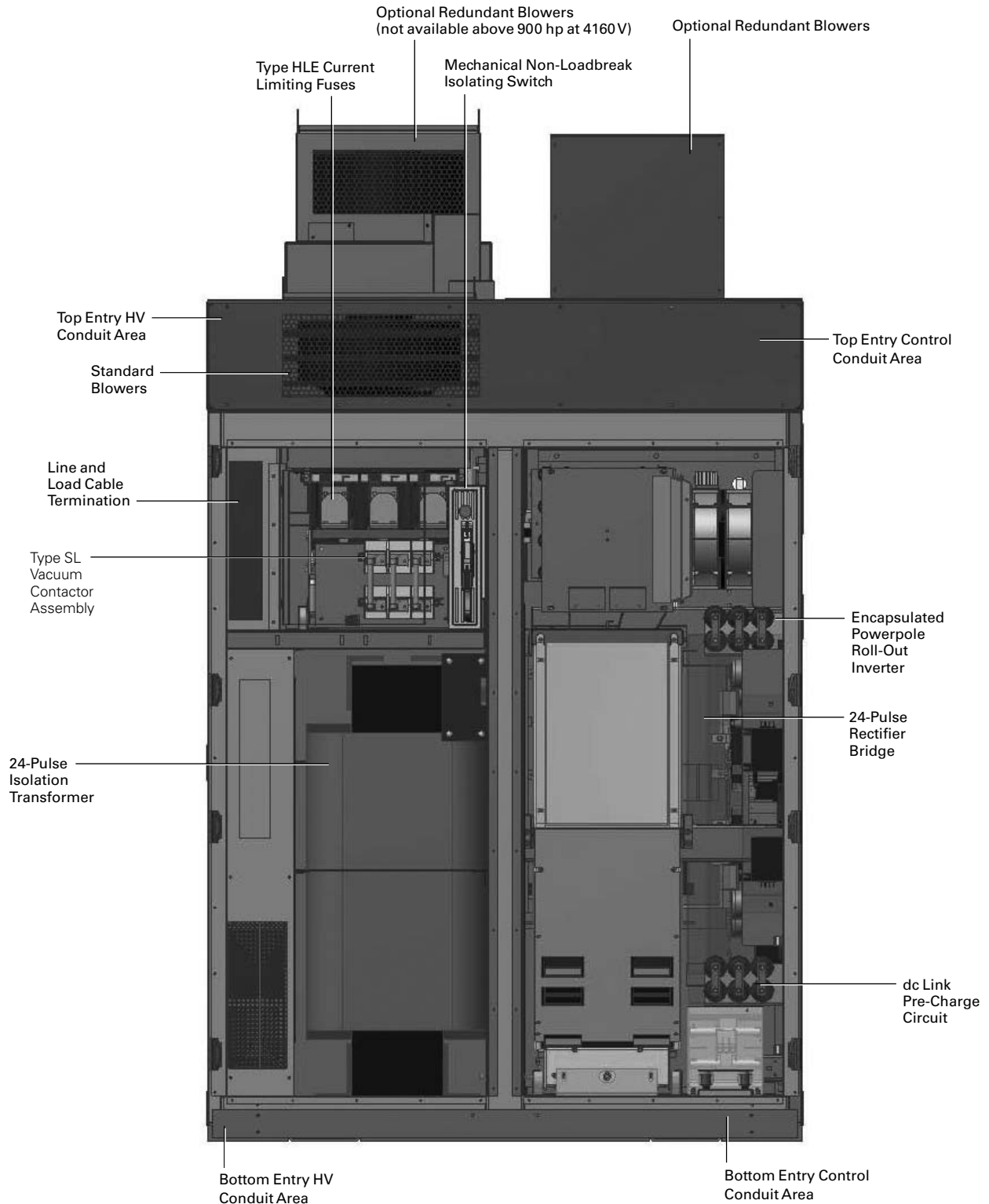

**Layout Dimensions—Frame A VFD
(300–1150 hp at 4160 V) (300–600 hp at 2400 V)**

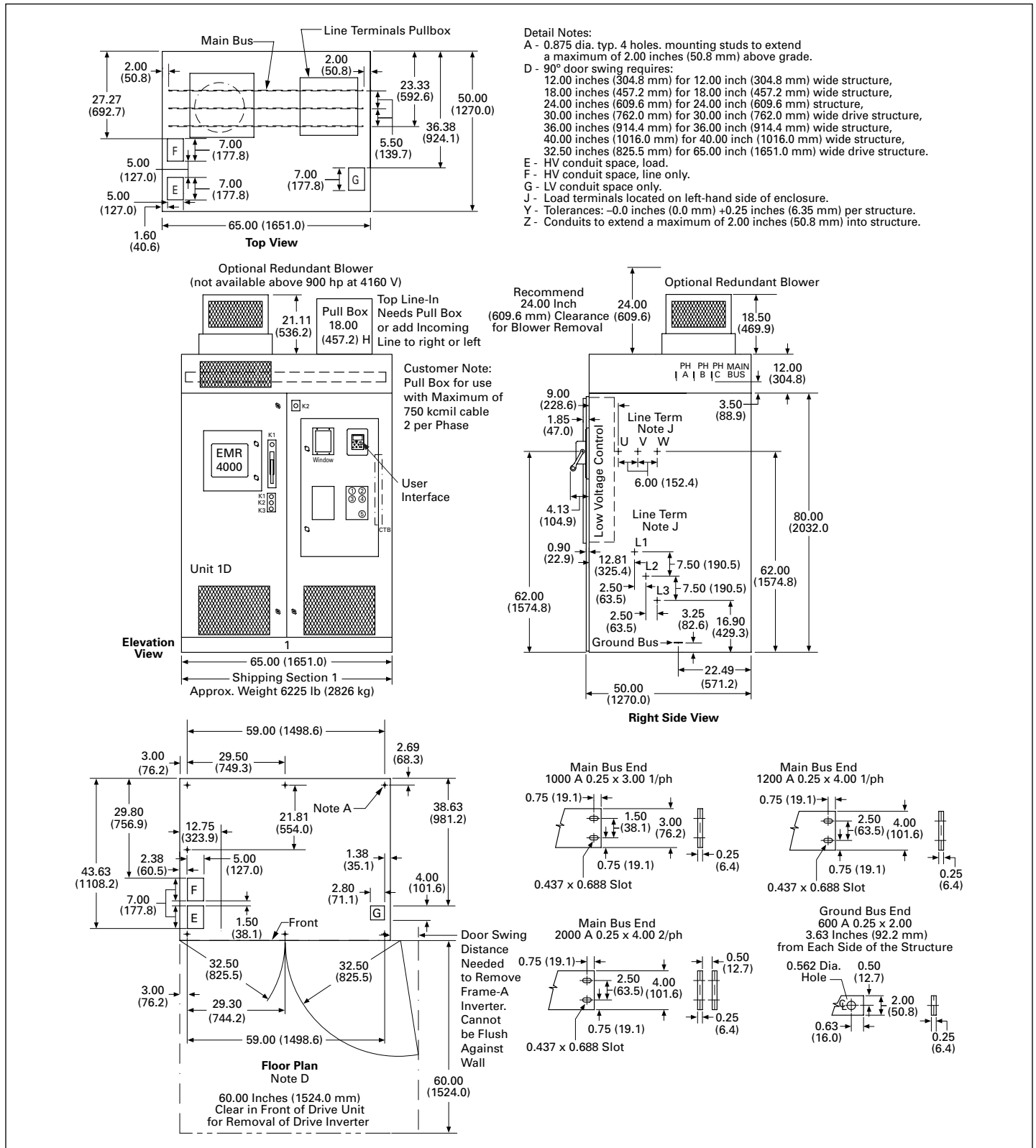
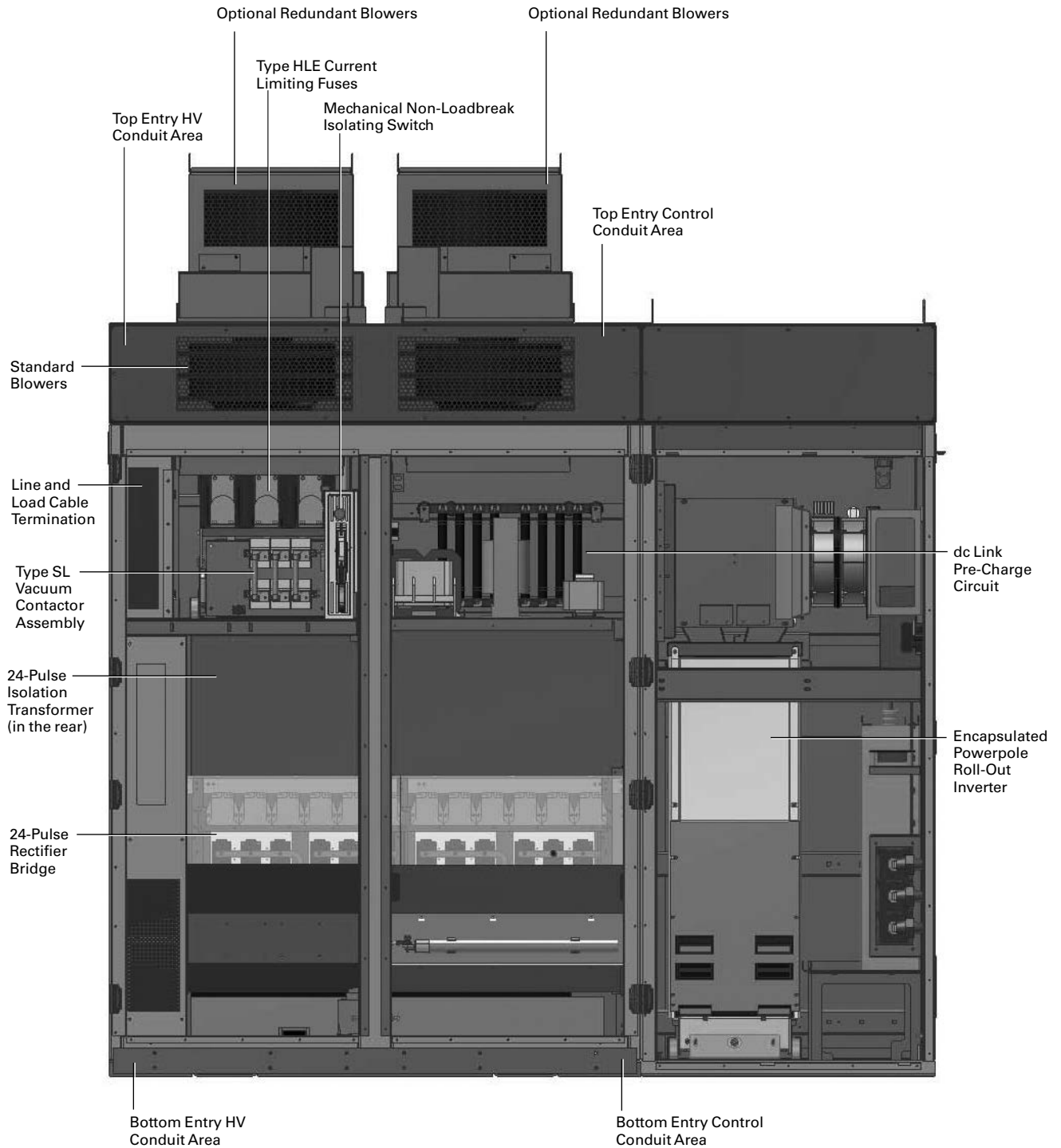

Figure 10.4-4. SC9000 EP VFD Frame A Maximum Dimensions and Incoming Line Layouts—Dimensions in Inches (mm)

**SC9000 EP Fully Integrated Frame B VFD
(1000–2000 hp at 4160 V) (600–1150 hp at 2400 V)**

Horsepower ratings based on 1800 RPM motors, variable torque, standard temperature and elevation.



**Layout Dimensions—Frame B VFD
(1000–2000 hp at 4160 V) (600–1150 hp at 2400 V)**

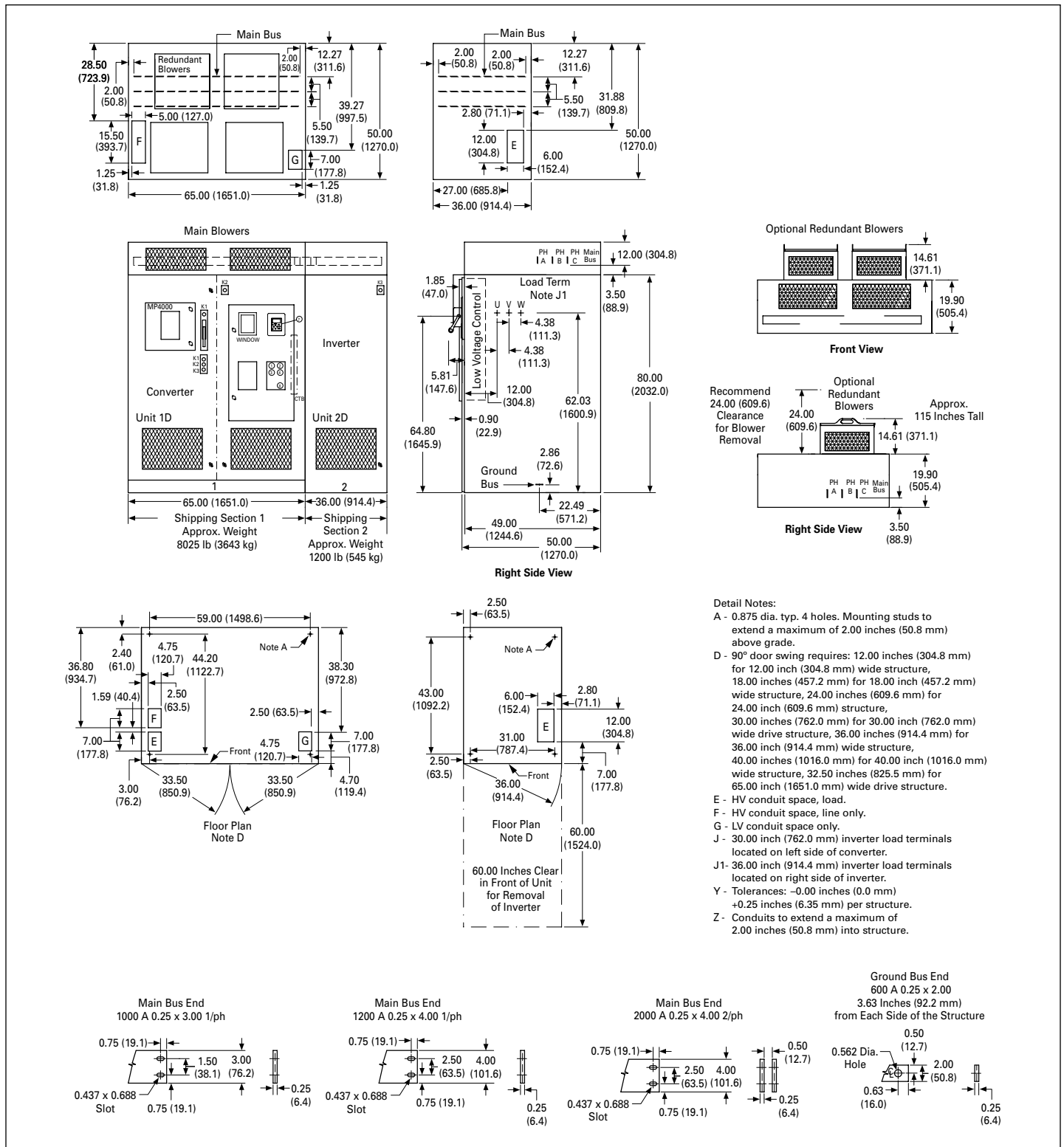
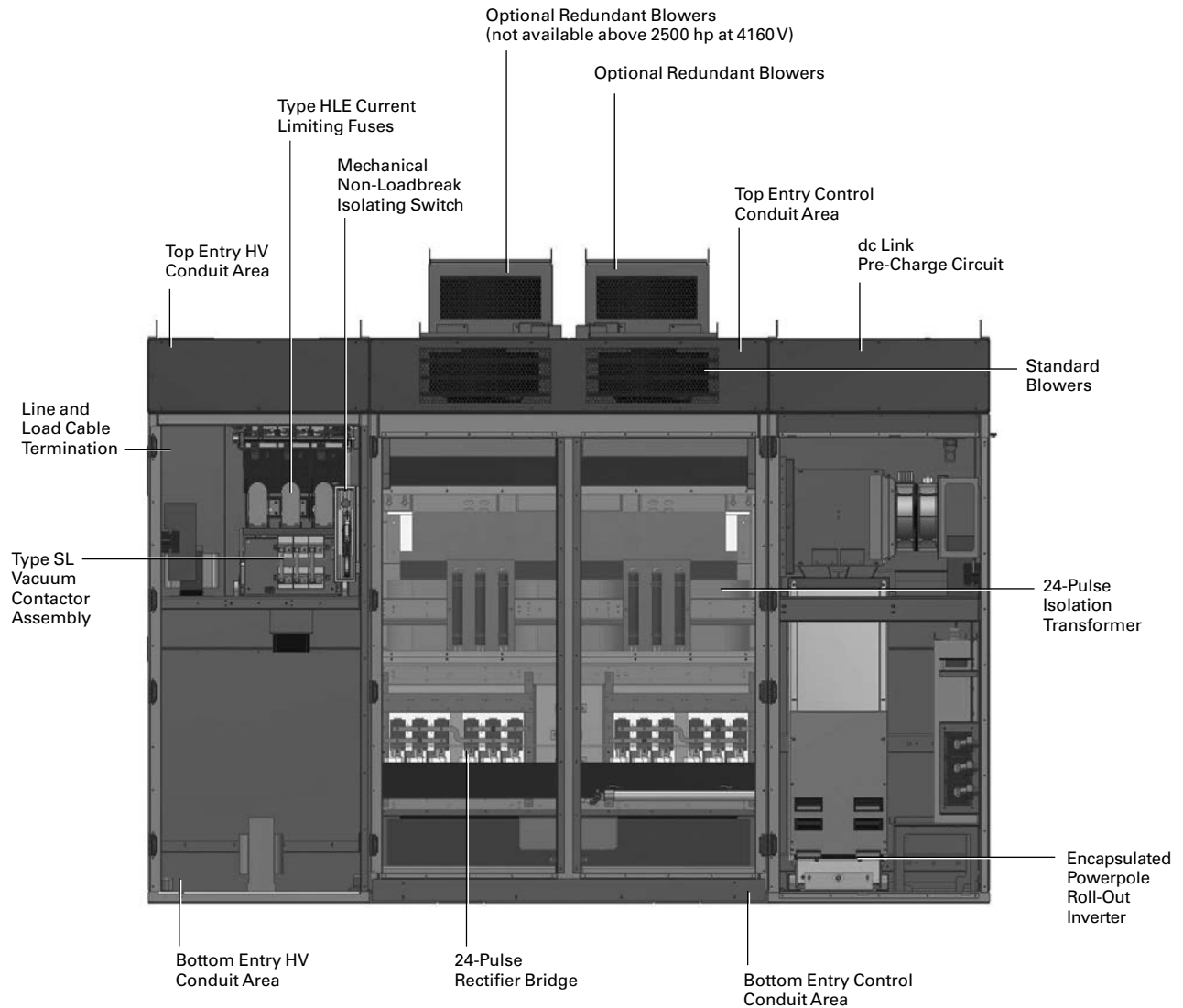

Figure 10.4-5. SC9000 EP VFD Frame B Maximum Dimensions and Incoming Line Layouts—Dimensions in Inches (mm)

**SC9000 EP Fully Integrated Frame C VFD
(2250–3000 hp at 4160 V) (1250–1750 hp at 2400 V)**

Horsepower ratings based on 1800 RPM motors, variable torque, standard temperature and elevation.



Note: See Page 10.4-16 for dimensional details.

**Layout Dimensions—Frame C VFD
(2250–3000 hp at 4160 V) (1250–1750 hp at 2400 V)**

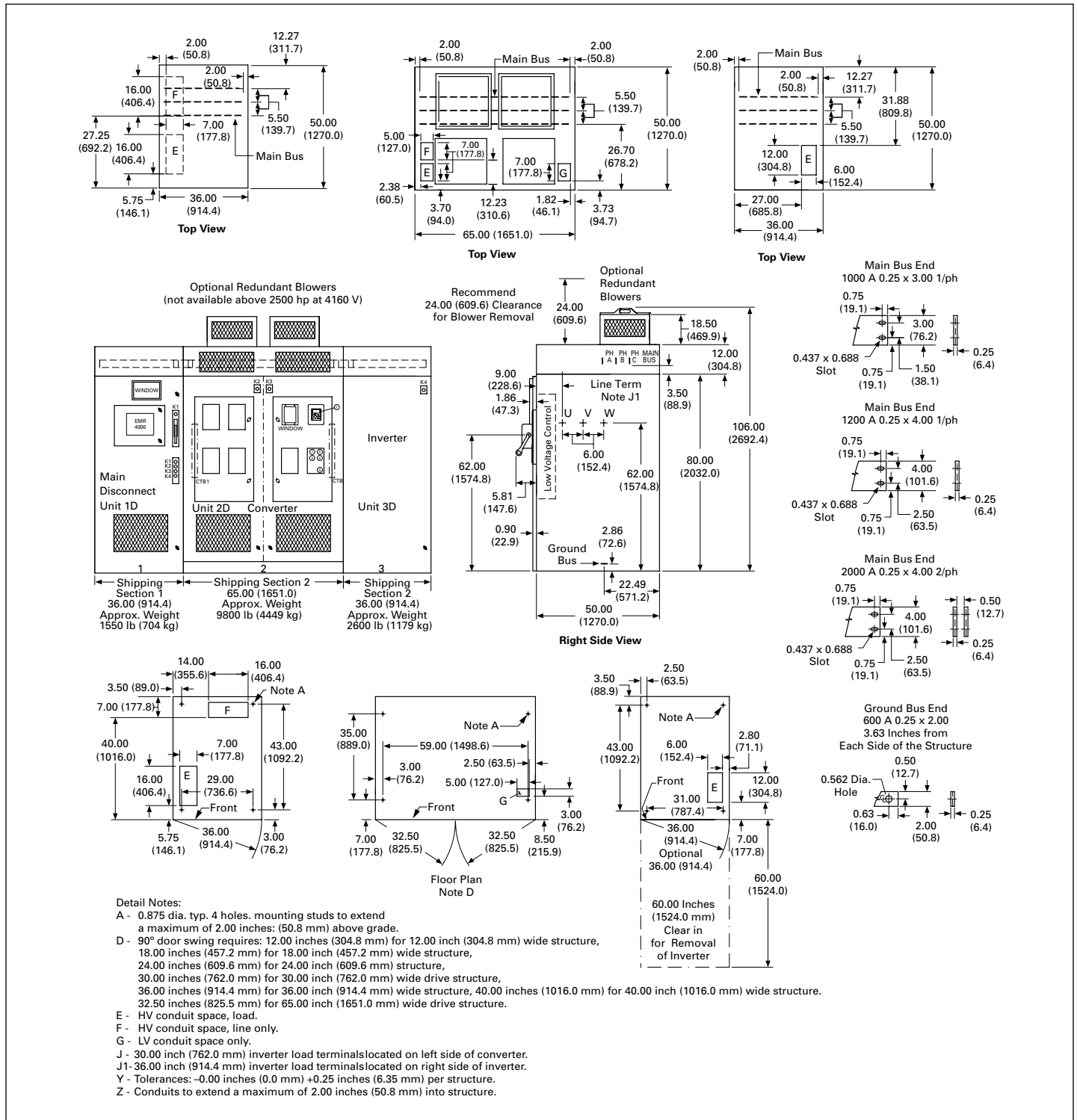
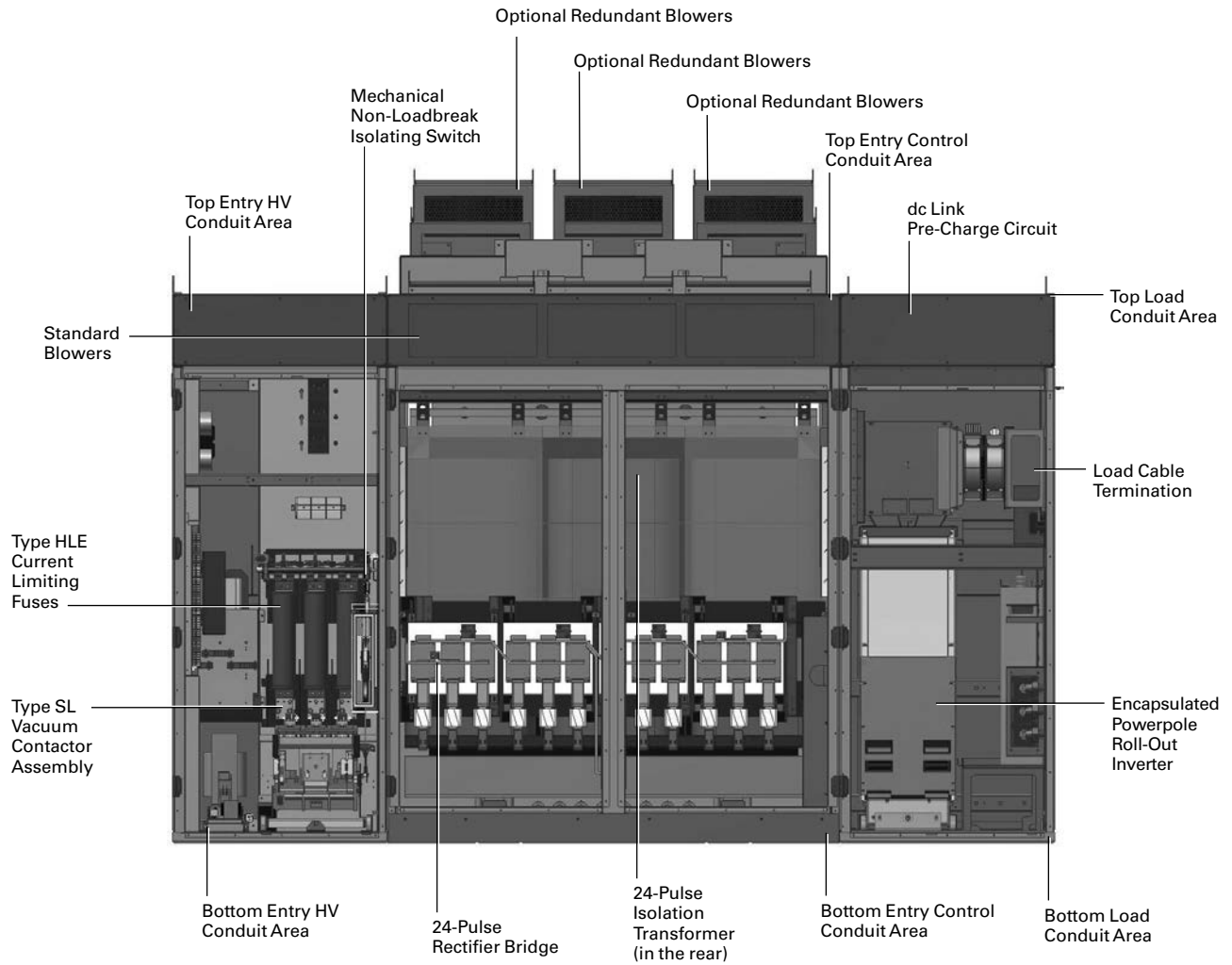

Figure 10.4-6. SC9000 EP VFD Frame C Maximum Dimensions and Incoming Line Layouts—Dimensions in Inches (mm)

**SC9000 EP Fully Integrated Frame D VFD
(3000–4500 hp at 4160 V) (2000–2500 hp at 2400 V)**

Horsepower ratings based on 1800 RPM motors, variable torque, standard temperature and elevation.



Layout Dimensions—Frame D VFD
(3000–4500 hp at 4160 V) (2000–2500 hp at 2400 V)

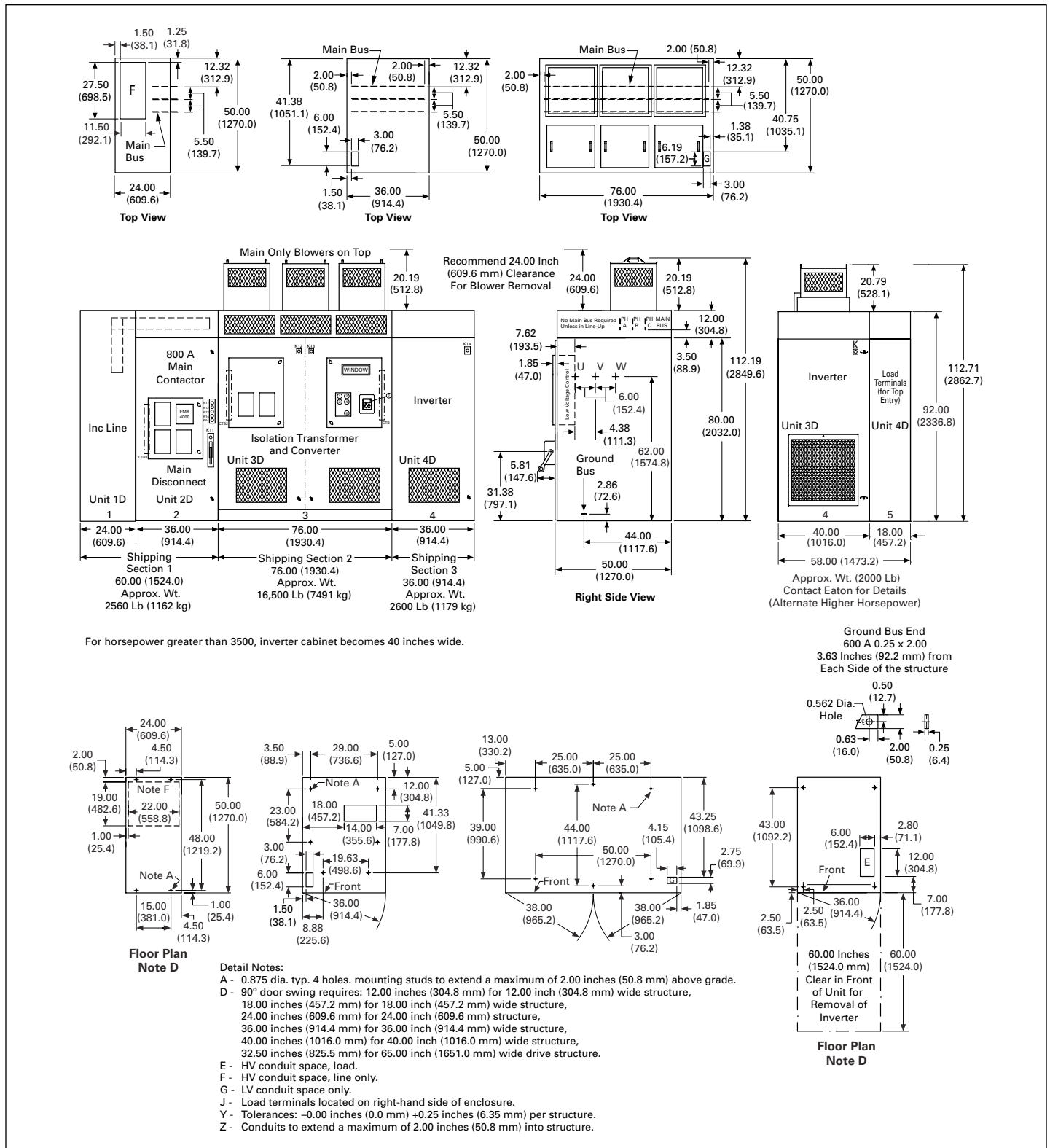
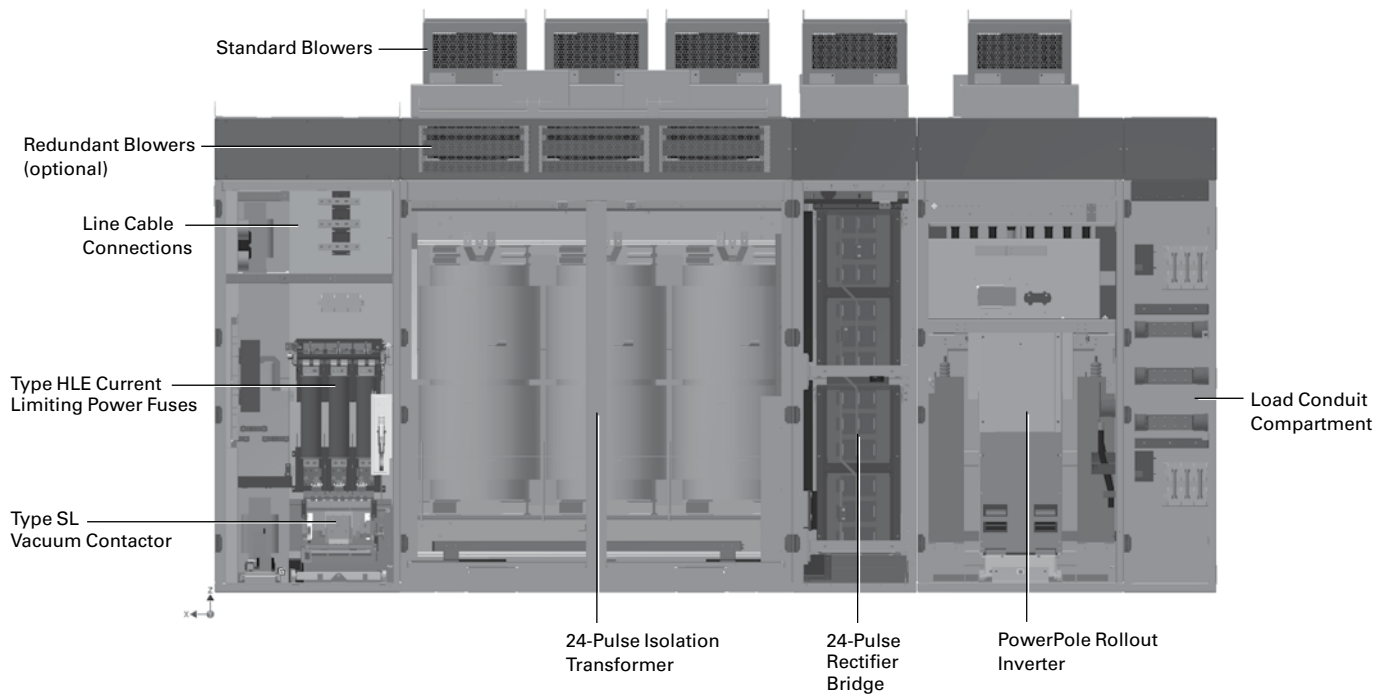

Figure 10.4-7. SC9000 EP VFD Frame D (Single Inverter) Maximum Dimensions and Incoming Line Layouts—Dimensions in Inches (mm)

SC9000 EP Fully Integrated Frame E VFD (Single Inverter)
(4750–5000 hp at 4160 V)

Horsepower ratings based on 1800 RPM motors, variable torque, standard temperature and elevation.



Layouts and Dimensions

Layout Dimensions—Frame E VFD (Single Inverter)
(4750–5000 hp at 4160 V)

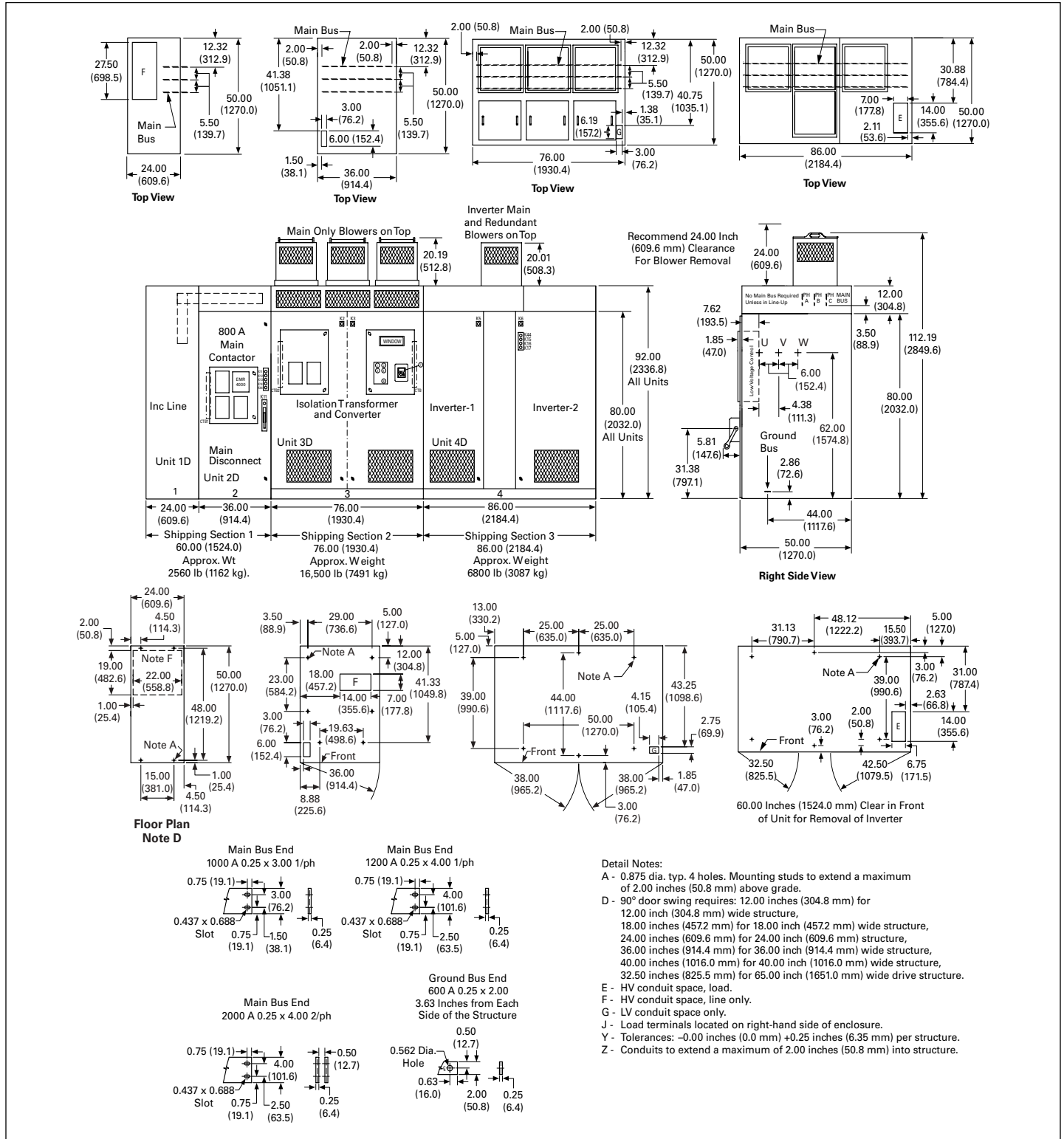

Figure 10.4-8. SC9000 EP VFD Frame D (Parallel Inverters) Maximum Dimensions and Incoming Line Layouts—Dimensions in Inches (mm)

**Layout Dimensions—Frame E VFD (Parallel Inverters)
(5250–6000 hp at 4160 V)**

Horsepower ratings based on 1800 RPM motors, variable torque, standard temperature and elevation.

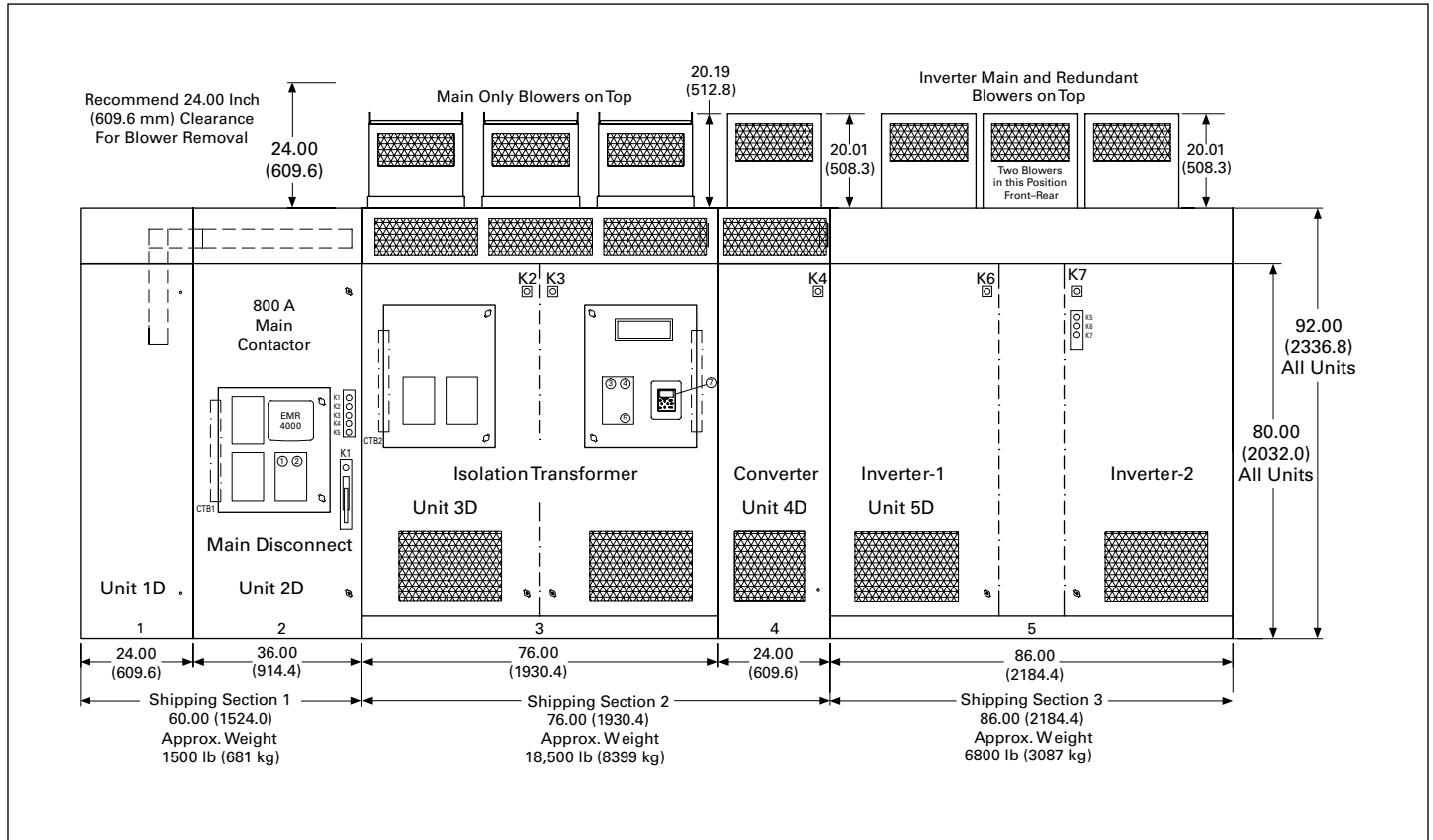

Figure 10.4-9. SC9000 EP Frame E—Dimensions in Inches (mm)

Table 10.4-3. SC9000 EP Frame E—Dimensions in Inches (mm)

Output Voltage	Motor		Cabinet Size			Redundant Blower
	FLA	hp	Width	Height	Depth	Height
3300 ①	520–640	3250–4000	222.00 (5638.8)	92.00 (2336.8)	50.00 (1270.0)	12.10 (307.3)
4160	620–713	5000–6000	222.00 (5638.8)	92.00 (2336.8)	50.00 (1270.0)	12.10 (307.3)

① 3300 V, 50 Hz.

Layout Dimensions—Integrated Ampgard Main Breaker for EP Only (Metal-Enclosed)

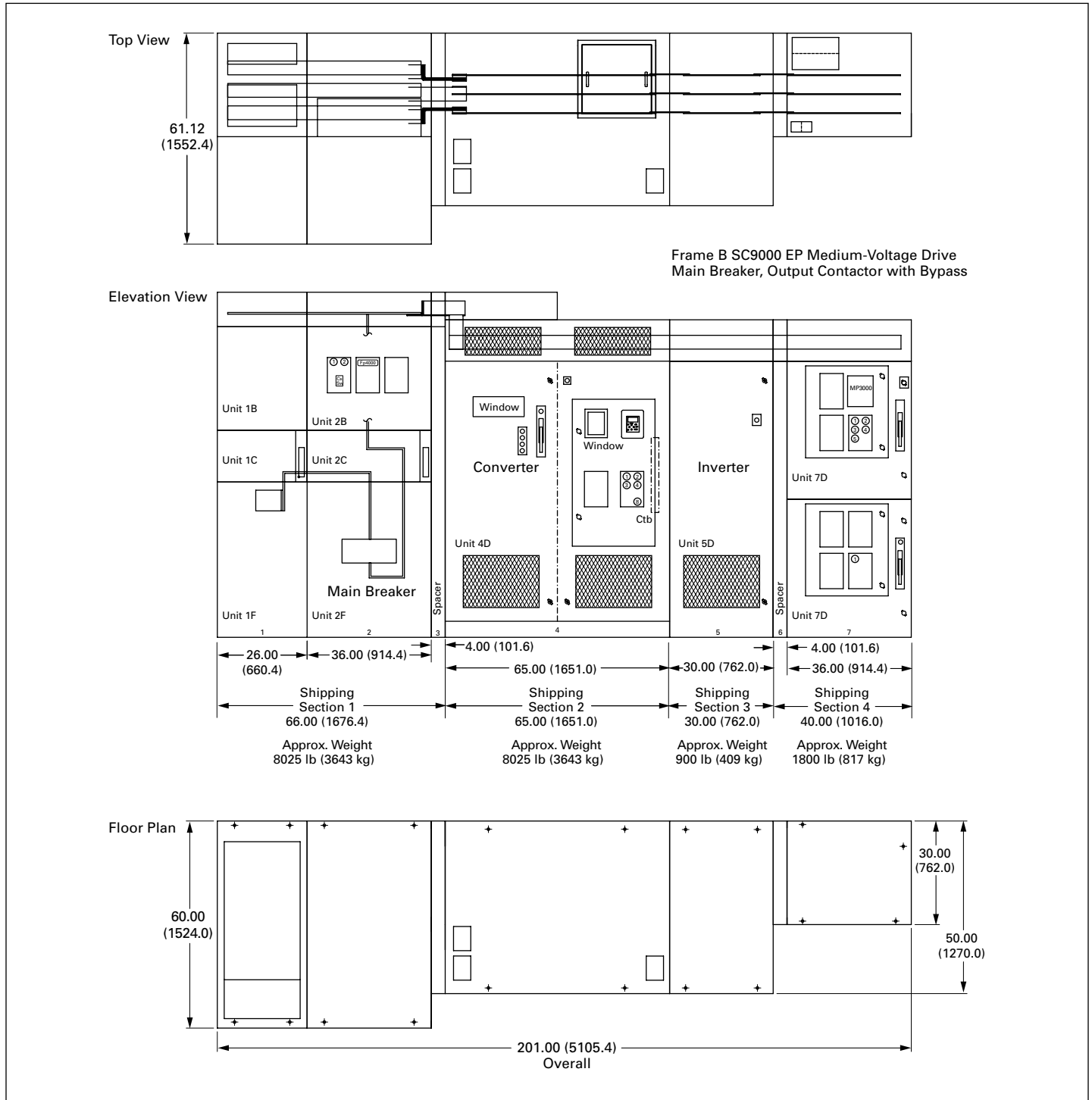

Figure 10.4-10. Eaton Medium-Voltage Integrated Control Gear with Main Breaker Dimensions—(See on Page 10.1-5 for information on main bus. Refer to Eaton for larger hp layouts and detailed assembly dimensions.)

Layout Dimensions—Optional 15 kV Input Voltage Compartment

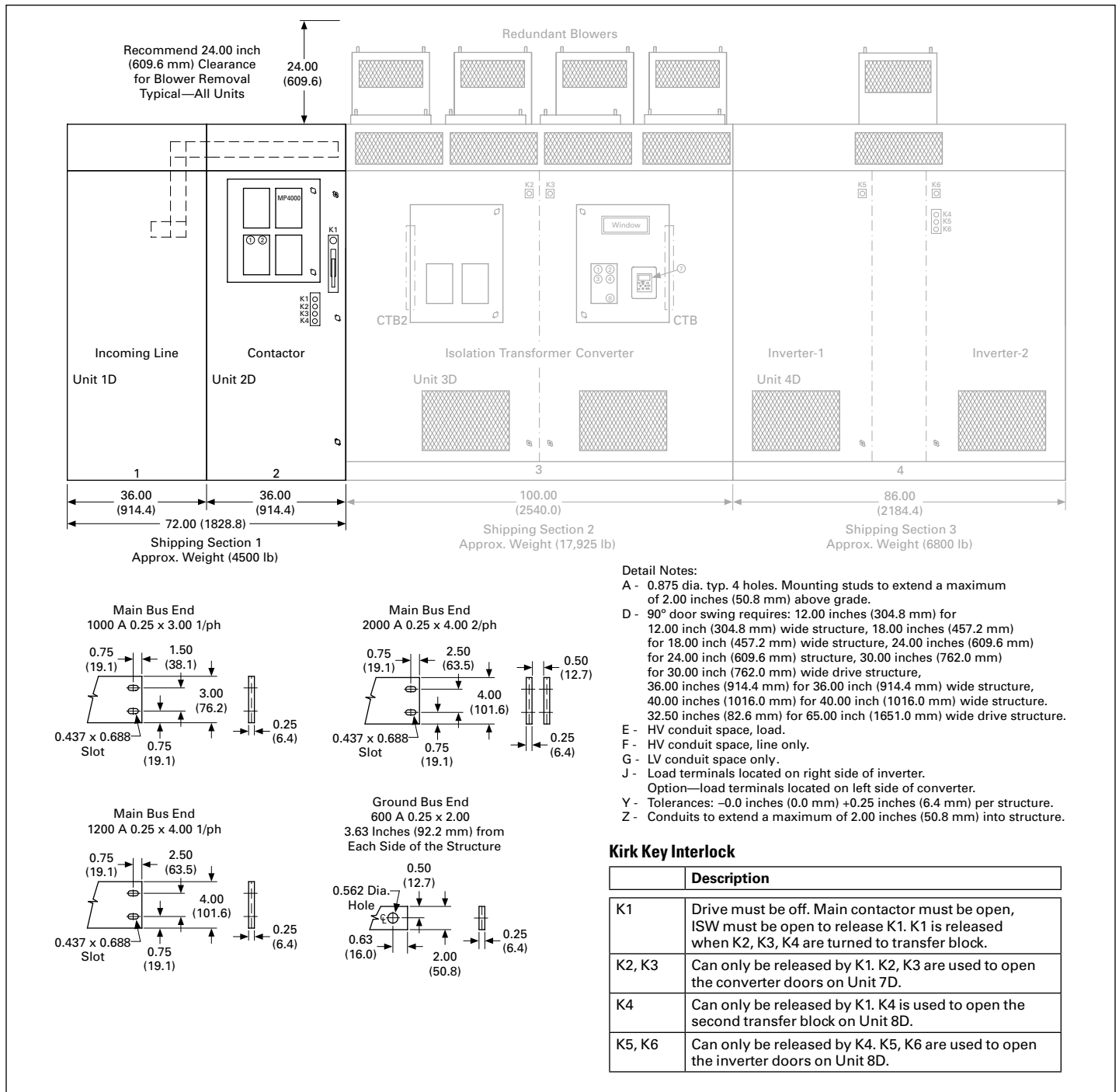

Figure 10.4-11. SC9000 EP Frame D (4500 hp) 4160 V with High-Voltage Input (for Reference Only, Available in All Frame Sizes)

Adjustable Frequency Drives With High-Voltage Input

The fully integrated SC9000 EP can be designed to receive input voltages from 2.4 to 13.8 kV, with output voltages of 2400 V, 3300 V and 4160 V, with 50 or 60 Hz available. The high-voltage input option eliminates the need of a separate distribution transformer, reduces overall footprint and simplifies overall installation. Please consult the factory for drive dimensions and incoming line section requirements.

Layout Dimensions —SC9000 EP VFDs Output Filters

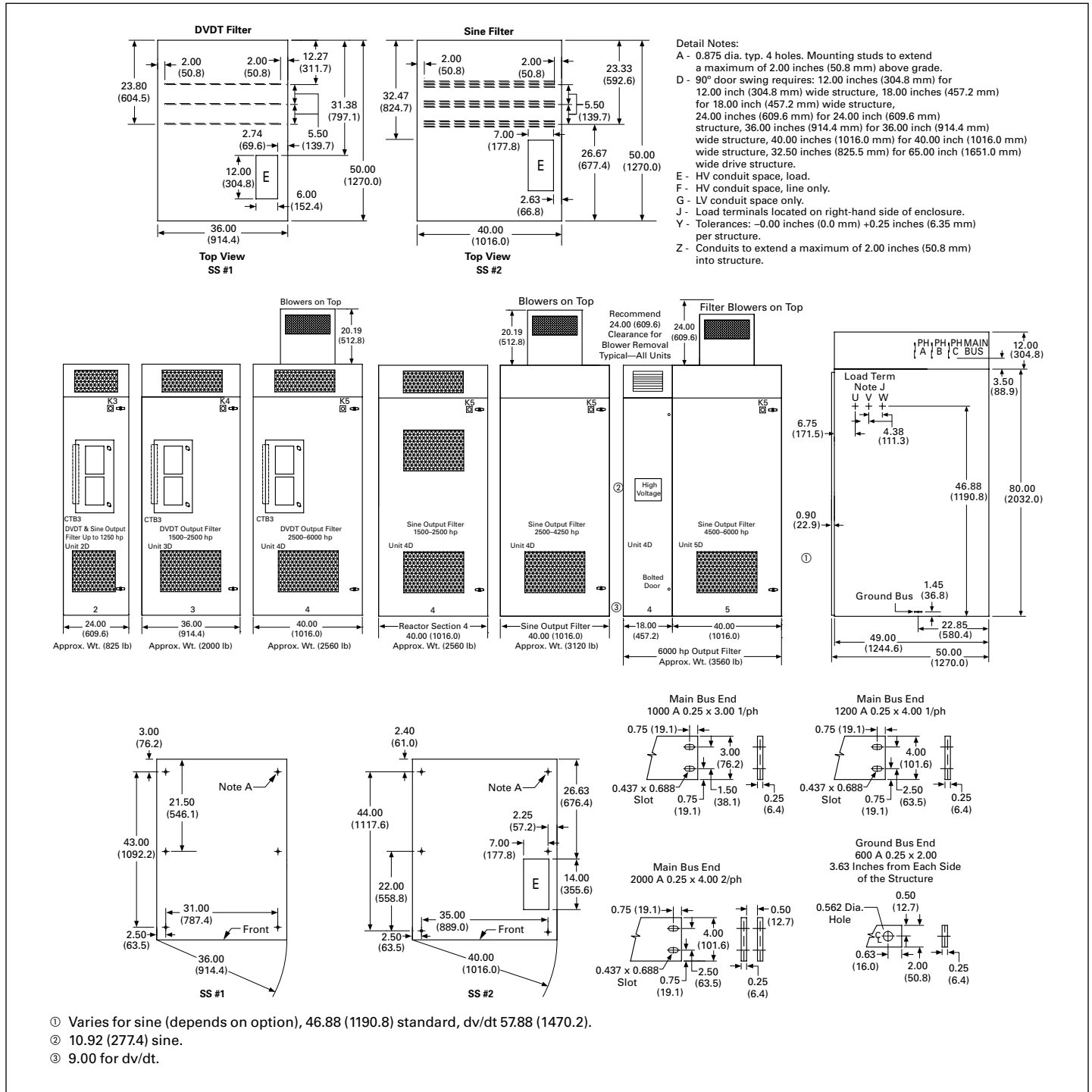

Figure 10.4-12. SC9000 EP VFD Output Filter Maximum Dimensions and Incoming Line Layouts—Dimensions in Inches (mm)

Layout Dimensions—SC9000 EP VFDs
Synchronous Transfer Systems

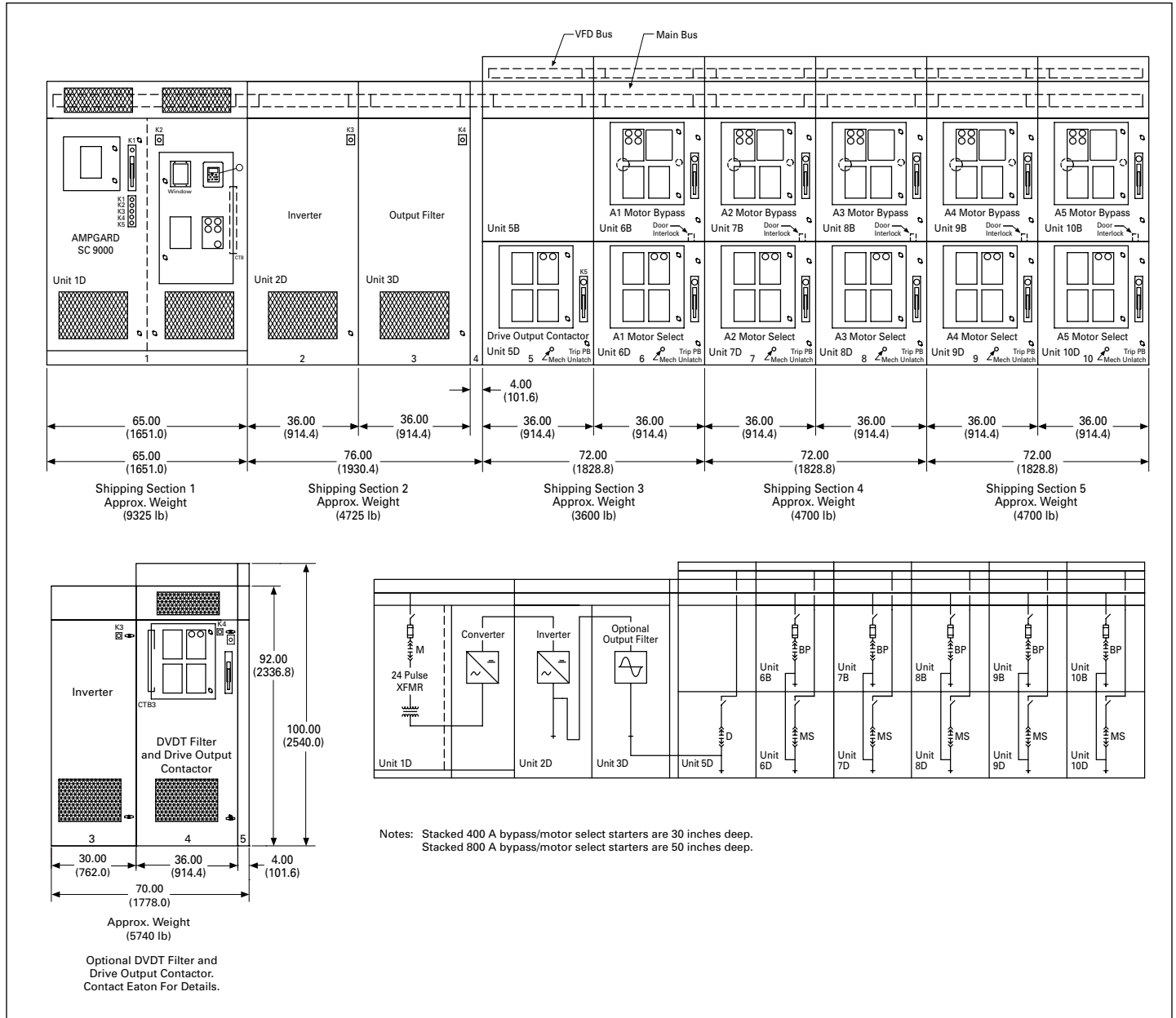

Figure 10.4-13. SC9000 EP Synchronous Transfer System with Five MV Starters (For Reference Only)

Synchronous Transfer Control with SC9000 EP



Synchronous Transfer Control System

General Description

Synchronous transfer systems help maximize capital efficiency by controlling multiple motors with one adjustable frequency drive.

Most manufacturers’ synchronous transfer control systems have multiple drive output and motor select contactors that are (typically) interconnected via cables to allow the VFD to manage multiple motors.

With the SC9000 EP and Eaton’s integrated medium-voltage control gear design; the double bus design, drive output, and motor select contactors are all close-coupled under a common bus with no cables, providing a more compact design and superior performance. Both 400 A and 800 A bypass/motor select starters can be provided in a 2-high stacked configuration.

Closed Transition Transfer Control Operation

Operation of Eaton’s Closed Transition Transfer Control System is described and illustrated below. Figure 10.4-14 shows the elements that make up an SC9000 EP Synchronous Transfer system.

Control Elements, Colors, and Symbols

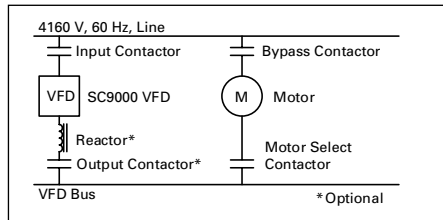
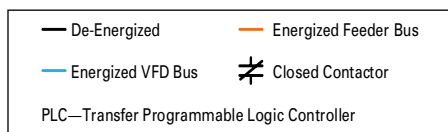

Figure 10.4-14. Closed Transition Synchronous Transfer Elements

Sequence of Operation

Start and sync-up sequence

- Customer sends start signal to PLC
- PLC closes the motor select contactor
- PLC sends run command to VFD
- VFD closes output contactor and pre-charges
- VFD closes input contactor (Figure 10.4-15)
- VFD ramps motor to reference frequency

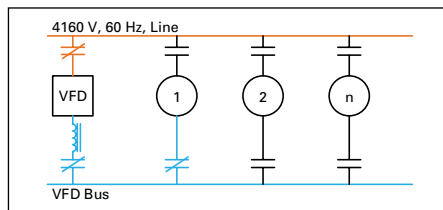

Figure 10.4-15. VFD Starts Motor #1

- Customer sends sync up signal to PLC
- PLC sends sync up command to VFD
- VFD locks output to match line voltage
- VFD sends sync acknowledgement to PLC
- PLC closes bypass contactor
- PLC opens motor select contactor (Figure 10.4-16)

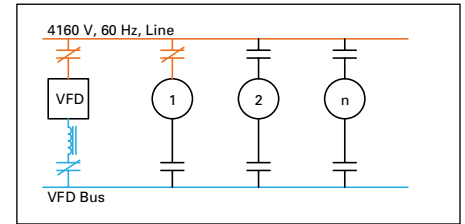

Figure 10.4-16. VFD Transfers Motor #1

- VFD stops inverter
- VFD opens drive output contactor (Figure 10.4-17)
- PLC removes sync up and run command from VFD

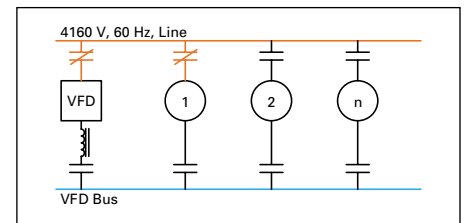

Figure 10.4-17. Motor #1 on Bypass

Sync Down Sequence

- Customer sends signal to PLC to sync down motor
- VFD closes main input contactor
- VFD locks to line voltage
- VFD closes drive output contactor
- VFD sends sync acknowledgment to the PLC

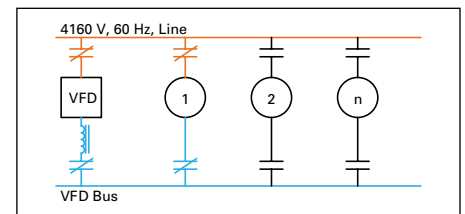

Figure 10.4-18. VFD Synced to Input

- PLC closes motor select (Figure 10.4-18)
- PLC sends command to VFD to turn on inverter
- PLC opens bypass contactor (Figure 10.4-19)
- VFD ramps motor to reference frequency

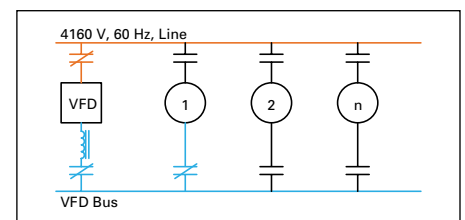

Figure 10.4-19. VFD Running Motor #1

Frame Size VT/CT Reference Chart

Table 10.4-4. SC9000 EP Frame A

See Figure 10.4-4.

2400/60 Hz VT		3300/50 Hz VT		4160/60 Hz VT	
FLA	hp	FLA	hp	FLA	hp
69	300	48	300	38	300
80	350	56	350	44	350
91	400	64	400	51	400
103	450	72	450	57	450
114	500	80	500	63	500
—	—	96	600	76	600
—	—	112	700	89	700
—	—	—	—	101	800
—	—	—	—	114	900
—	—	—	—	124	1000 ①
—	—	—	—	132	1150 ①

2400/60 Hz CT		3300/50 Hz CT		4160/60 Hz CT	
FLA	hp	FLA	hp	FLA	hp
69	300	48	300	38	300
80	350	56	350	44	350
—	—	64	400	51	400
—	—	72	450	57	450
—	—	80	500	63	500
—	—	—	—	76	600

① Requires second blower configuration. Redundant blowers not available.

Table 10.4-5. SC9000 EP Frame B

See Figure 10.4-5.

2400/60 Hz VT		3300/50 Hz VT		4160/60 Hz VT	
FLA	hp	FLA	hp	FLA	hp
134	600	128	800	124	1000
156	700	144	900	155	1250
178	800	160	1000	186	1500
201	900	200	1250	217	1750
223	1000	240	1500	248	2000

2400/60 Hz CT		3300/50 Hz CT		4160/60 Hz CT	
FLA	hp	FLA	hp	FLA	hp
91	400	96	600	89	700
103	450	112	700	101	800
114	500	128	800	114	900
134	600	144	900	124	1000
156	700	160	1000	155	1250

Table 10.4-6. SC9000 EP Frame C

See Figure 10.4-6.

2400/60 Hz VT		3300/50 Hz VT		4160/60 Hz VT	
FLA	hp	FLA	hp	FLA	hp
279	1250	280	1750	279	2250
335	1500	320	2000	310	2500
390	1750	—	—	341	2750 ②
—	—	—	—	372	3000 ②

2400/60 Hz CT		3300/50 Hz CT		4160/60 Hz CT	
FLA	hp	FLA	hp	FLA	hp
178	800	200	1250	186	1500
201	900	—	—	217	1750
223	1000	—	—	248	2000
279	1250	—	—	—	—

② Requires second blower configuration. Redundant blowers not available.

Table 10.4-7. SC9000 EP Frame D

See Figure 10.4-7 and Figure 10.4-8.

2400/60 Hz VT		3300/50 Hz VT		4160/60 Hz VT	
FLA	hp	FLA	hp	FLA	hp
448	2000	360	2250	403	3250
504	2250	400	2500	434	3500
561	2500	440	2750	461	3750
—	—	480	3000	493	4000
—	—	—	—	527	4250
—	—	—	—	558	4500

2400/60 Hz CT		3300/50 Hz CT		4160/60 Hz CT	
FLA	hp	FLA	hp	FLA	hp
335	1500	240	1500	279	2250
390	1750	280	1750	310	2500
448	2000	320	2000	341	2750
—	—	—	—	372	3000
—	—	—	—	403	3250

Table 10.4-8. SC9000 EP Frame E

See Figure 10.4-9.

2400/60 Hz VT		3300/50 Hz VT		4160/60 Hz VT	
FLA	hp	FLA	hp	FLA	hp
—	—	—	—	589	4750 ③
—	—	—	—	620	5000 ③
—	—	—	—	651	5250
—	—	—	—	682	5500
—	—	—	—	713	5750
—	—	—	—	744	6000

2400/60 Hz CT		3300/50 Hz CT		4160/60 Hz CT	
FLA	hp	FLA	hp	FLA	hp
—	—	360	2250	434	3500
—	—	400	2500	461	3750
—	—	—	—	493	4000

③ Single inverter configuration.

VT = Variable Torque (110% overload for 1 minute every 10 minutes)

CT = Constant Torque (150% overload for 1 minute every 10 minutes)

Table 10.4-9. SC9000 EP Adjustable Frequency Drive Efficiency, Power Factor and Harmonics Typical Data

Description	Load (%)		
	50	75	100
Speed: 50%			
Input PF (1)	0.96	0.98	0.98
InputTHD (V)	3.13	3.64	3.43
InputTHD (I)	7.59	6.40	6.73
Efficiency (%)	0.943	0.959	0.962
Speed: 75%			
Input PF (1)	0.98	0.99	0.99
InputTHD (V)	1.34	2.32	3.15
InputTHD (I)	6.76	4.44	3.85
Efficiency (%)	0.965	0.970	0.971
Speed: 100%			
Input PF (1)	0.98	0.99	0.99
InputTHD (V)	2.16	2.20	2.30
InputTHD (I)	5.95	4.38	3.13
Efficiency (%)	0.971	0.972	0.974

Table 10.4-10. SC9000 EP Adjustable Frequency Drive Heat Loss Data ①

Horsepower	Watts Loss as Heat	Horsepower	Watts Loss as Heat	Horsepower	Watts Loss as Heat
200	4600	900	20,700	3000	69,000
300	6900	1000	23,000	3500	80,500
350	8050	1250	28,750	3700	85,100
400	9200	1500	34,500	3750	86,250
450	10,350	1750	40,250	4000	92,000
500	11,500	2000	46,000	4500	103,500
600	13,800	2250	51,750	5500	126,500
700	16,100	2500	57,500	6000	138,000
800	18,400	2750	63,250	—	—

① Estimate additional 2 watt/hp heat loss for DVDT or sine filter (see IB20002EN for more details).

Typical Schematic

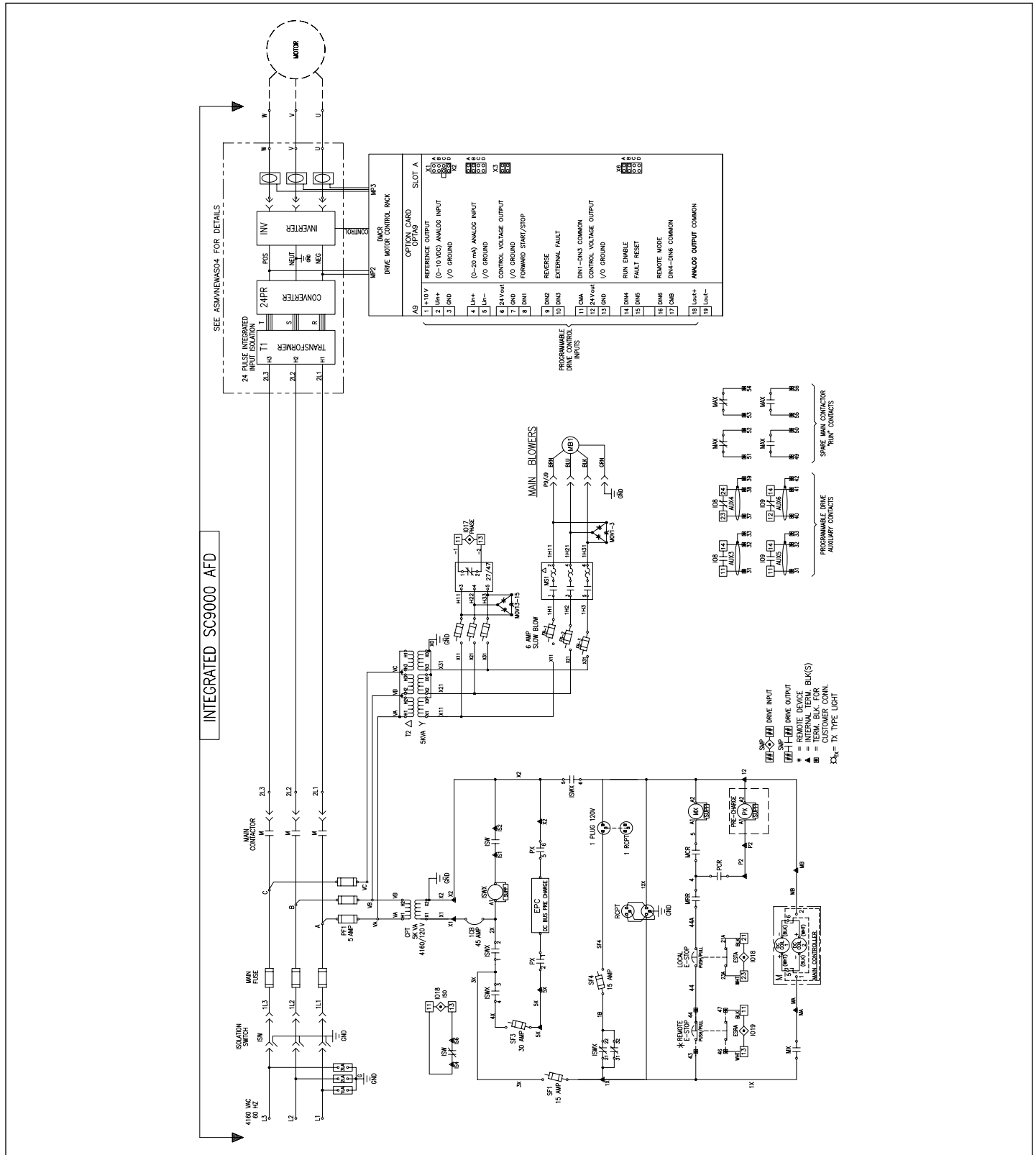

Figure 10.4-20. Typical Schematic for SC9000 EP VFD

