

Low-voltage power distribution and control systems > Pow-R-Command lighting control >

Lighting control systems — Pow-R-Command

Contents

Lighting Control Systems—Pow-R-Command	23.1-2	Connecting Field Wiring Control Devices	23.1-21
General Description	23.1-2	Digital Inputs	23.1-21
Controller Features	23.1-2	Analog Inputs	23.1-22
Panelboard Options	23.1-2	Analog Outputs	23.1-22
System Options	23.1-2	Analog I/O Expansion Module	23.1-23
Pow-R-Command Panelboard Electronics and Controllable Circuit Breakers	23.1-3	PRC Advanced Controllers	23.1-26
Controllers	23.1-3	PRC5000E Master Controller	23.1-26
Controller Selection	23.1-4	Applications	23.1-27
External Mounted Controllers	23.1-6	Typical Electric Room Layout	23.1-27
Breaker Control Bus	23.1-7	Multi-Story Building	23.1-28
Controllable Circuit Breakers	23.1-7	Manual Occupant Light Level Dimming Control	23.1-29
Master and Expansion Panelboards	23.1-9	Automatic Daylight Harvesting Dimming Control	23.1-30
Master Panelboard	23.1-9	Remote Mounted Analog Expansion Module	23.1-31
Expansion Panelboard	23.1-10	Emergency Lighting Control	23.1-32
Powered Expansion Panelboard	23.1-11	Remote Relay Unit (RRU-1)	23.1-33
Master Panelboard to Expansion Panelboard SLAN Sub-Net Network	23.1-12	Emergency Power Control (CEPC-1)	23.1-34
Networks	23.1-13	UL 924 Uninterruptible Power Supply	23.1-35
Ethernet Networks	23.1-13	Receptacle Control	23.1-36
MLAN Networks	23.1-14	Integrated Metering	23.1-37
Digital Switches and Low-Voltage Switches	23.1-15	PXBCM Branch Circuit Monitor	23.1-38
Digital Network Switches	23.1-15	Building Management System Integration	23.1-39
Digital Switch Network (DSN)	23.1-17	Third-Party Modbus Master Control Connection	23.1-40
Low-Voltage Switches (PRCLS)	23.1-19	Panelboard Pow-R-Command Retrofits	23.1-41
Switch Wallplates (PRCSWP)	23.1-20		



Powering Business Worldwide



More about this product
Eaton.com/lightingcontrol



Complete library of design guides
Eaton.com/designguides

General Description



Pow-R-Command™ is a lighting control and energy management system that integrates branch circuit protection, control (switching and dimming) and metering into a single panelboard enclosure. The integrated design simplifies electrical distribution and control system design, and eliminates separate equipment enclosures and associated wiring. Other benefits include smaller equipment wall space requirement, reduced installation labor and lower total installed cost.

Pow-R-Command systems are designed to meet or exceed ASHRAE, IECC and LEED® requirements. Pow-R-Command Intelligent Panelboards use Eaton Pow-R-Line® 1a and 2a lighting panelboard platforms to mount Pow-R-Command electronics and solenoid-operated controllable circuit breakers.

Controller Features

Pow-R-Command controllers are available in two different models (PRC750E and PRC2000E). Controller features depend on the model number. Available features include:

- 365-day time clock
- Astronomical time clock with sunrise and sunset offsets
- Holiday and daylight savings time schedules
- Low-voltage inputs for occupancy-based and occupant override control
- Digital Switch Network (DSN) for connecting Pow-R-Command Digital Switches
- Analog inputs for connecting light level sensors
- Analog outputs provides manual dimming and automatic daylight harvesting control
- Backlit LCD touchscreen and Ethernet Maintenance Port for front panel programming, monitoring and override control
- Safe and easy access to low-voltage field wiring by loosening two captive screws and folding display down
- Ethernet and RS-485 network communications
- Peer-to-peer controller communications protocol
- Master/Expansion panelboard sub-network (SLAN) communications
- Preconfigured web pages access from Maintenance Port and ethernet network for system programming, monitoring and override control
- BACnet/IP communications protocol for integrating with building management systems
- Email notification of system alarms
- ModbusTCP pass-through mode for providing metering information
- Demand response logic
- Configurable source logic (OR, AND, XOR, NAND, LAST EVENT)
- Downloadable firmware for updating controller features
- System events logging
- Compatible with previous generation PRC systems

See **Table 23.1-1** for controller selection chart.

Panelboard Options

Pow-R-Command panelboards are assembled using Eaton Pow-R-Line 1a and 2a lighting panelboards. Pow-R-Command panelboard options include:

- NEMA® 1, 12, 3R and 4X enclosures
- Surface and flush mounting
- Column-width and Integrated
- Facility System (IFS) construction
- Main lug and main circuit breaker 100 A, 225 A and 400 A panelboard interiors
 - Interior sizes include 18-, 30-, 42- and 84-circuit configurations
- Service entrance label
- Retrofits into existing panelboard enclosures (consult factory)
- GHQRD single- and two-pole, 15 A, 20 A and 30 A controllable circuit breakers suitable for 480Y/277 Vac loads
- GHQRDEL 15 A and 20 A emergency lighting controllable circuit breakers
- BABRSP single-pole 15 A, 20 A and 30 A and two-pole 15 A, 20 A, 30 A, 40 A and 50 A controllable circuit breakers suitable for 208/120 Vac and 120/240 Vac loads
- Branch circuits series ratings
- Surge suppression devices
- PXM350 panelboard meter and PXBCM Branch Circuit Monitor

System Options

Pow-R-Command lighting control systems are used for a wide range of applications. The following system options are commonly used to meet control sequence, remote access and system maintenance requirements:

- Digital network wall switches
- Low-voltage momentary wall switches
- Photosensors (outdoor, indoor, skylight and atrium)
- Analog expansion modules
- (PRCEAEM) designed for dimming control
- Low-voltage input and analog I/O expansion modules
- PRC5000E Master Controller with optional custom building graphics

Consult factory for system options not listed above.

Controllers

Pow-R-Command 5th generation “E” Series controller family includes PRC2000E and PRC750E models. Specifiers select the controller to meet specific control and communication requirements. Controllers are shipped in two basic mounting configurations: integrated into Pow-R-Line 1a and 2a lighting panelboard or externally mounted in a controller cabinet.



PRC-E Controller

Controller standard features include:

- Color backlit high resolution LCD touchscreen for front panelboard programming, monitoring and override control
- Schedule, occupancy and override control logic low-voltage digital inputs to connect switches and occupancy sensors
- Local controller programming using ethernet connection
- Maintenance Port to access controller web pages or use Lighting Optimization Software (PRCLOS)
- Master panelboard to Expansion Panelboard SLAN sub-net network communications port
- Control and monitor up to 168 solenoid-operated circuit breaker poles

Controller optional features include:

- Analog I/O to provide 0–10 Vdc dimming and daylight harvesting control
- Digital Switch Network (DSN)
- RS-485 serial network communications (CNET)
- Ethernet network communications
- Powerful peer-to-peer communications protocol to provide global commands
- BACnet/IP protocol for straight-forward integration with building management systems
- Remote access to onboard web pages over ethernet network connection

Controller low-voltage compartment is located behind the LCD touchscreen display. Access is achieved by loosening the top two captive screws located at the top of each side of the display.

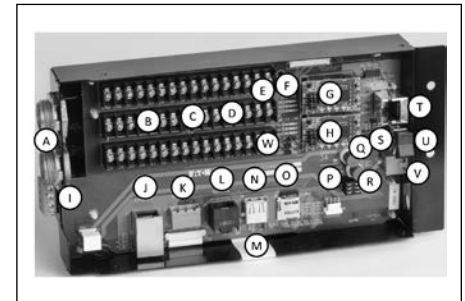

Figure 23.1-1. Controller Low-Voltage Compartment

- A. Low-voltage cables entry
- B. Digital inputs
- C. Universal inputs (digital or analog)
- D. Analog outputs
- E. External power source (12 Vdc and PWR)
- F. BCB status LEDs
- G. Digital Switch Network auxiliary board (DSN)
- H. RS-485 controller network auxiliary board (CNET)
- I. SLAN connector
- J. Ethernet network connector
- K. RS-485 controller network connector (CNET)
- L. Digital Switch Network connector (DSN)
- M. LCD touchscreen display connector
- N. USB connector
- O. SD card connector
- P. Service connector “factory use only”
- Q. External power 1.0 A fuse (Littelfuse Part #37211000411)
- R. Internal power 1.0 A fuse (Littelfuse Part #37211000411)
- S. Status LEDs
- T. Maintenance Port (Ethernet)
- U. ON/OFF power switch
- V. Controller power connection (Vin)
- W. MLAN communications for connecting Analog Expansion Modules (PRCEAEM) and Modbus RTU compatible metering devices



Controller Selection

Table 23.1-1 can be used to select the controller that includes features needed to meet application requirements. Table 23.1-2 provides additional details to aid in controller selection.

Table 23.1-1. Controller Selection

Features	PRC2000E Master Panelboard	PRC750E Master Panelboard	Expansion Panelboard
Schedule-based control Occupant override control Master/Expansion SLAN	■	■	
Dimming/daylight harvesting control Digital Switch Network RS-485 network communications MLAN device expansion network	■		
Ethernet communications BACnet/IP protocol	■		
Email notification ModbusTCP ethernet pass-through	■		
Access to controller web server	Maintenance Port Ethernet Network	Maintenance Port Only	
Modbus RTU communications			■

Table 23.1-2. PRC-E Controller Features

	PRCEP	 PRC750E	 PRC2000E
Inputs			
Dry-contact inputs	—	16	8
Universal inputs, configurable dry-contact or analog 0–10Vdc	—	—	8
Outputs			
Maximum number of controllable circuit breakers	—	168	168
Analog outputs, 0–10Vdc, 80 mA sink or 40 mA source current ①	—	—	8
Power supply to power external devices, 100 mA at 12Vdc/30Vac	—	■	■
Power supply to power integrated Breaker Control Bus and SLANV+ and V–	PRCEPP	■	■
Inputs and Outputs Accessory Modules			
Analog Expansion Module (PRCEAEM) w/ 8 universal inputs configurable as maintained dry-contact or analog 0–10Vdc, 8 analog outputs 0–10Vdc at 80 mA sink or source current ①②④	—	—	8 UI/8 AO
Switch Override Controller (PRCSOC) w/ 60 maintained dry-contact inputs, optional card includes 32 two-wire 24Vdc outputs for status LEDs ③⑤	—	—	60 I/ 32 O
Control Logic			
Panelboard configurations include 18, 30, 42, 60, 72 and 84 circuits	—	■	■
Maximum number of control groups, 17–250 groups require PRCLOS software configuration	—	16	250
365-day time clock	—	■	■
Astronomical time clock with sunrise and sunset offsets	—	■	■
Schedules	—	250	250
Holidays	—	32	32
Automatic daylight savings time	—	■	■
Circuit breaker blink notice	—	■	■
Override time switches	—	■	■
Manual dimming and automatic daylight harvesting	—	—	■
Configurable source logic (OR, AND, XOR, XNOR, NAND and LAST EVENT)	—	—	■
Communications			
Expansion panelboard SLAN	■	■	■
Maximum Breaker Control Bus (BCB) per SLAN	—	8	8
Ethernet network	—	—	■
BACnet/IP protocol	—	—	■
Email notification, user configurable alarms	—	—	■
Pow-R-Command RS-485 (CNET)	—	—	■
Digital Switch Network (DSN)	—	—	■
MLAN communications to Analog Expansion Module (PRCEAEM) ②	—	—	■
MLAN communications to metering devices with Modbus RTU communications ⑥	—	—	■
ModbusTCP pass-through metering mode	—	—	■
Modbus RTU, Breaker Control Bus addresses 1–16	■	—	—
Local Programming			
4.3-inch backlit color LCD touchscreen	—	■	■
Front Maintenance Port (ethernet) access to web server ⑦	—	■	■
PRC Lighting Optimization Software (PRCLOS), Maintenance Port (ethernet) access ⑦	—	■	■
Password protection	—	■	■
Remote Programming			
Remote access to controller web server via ethernet connection	—	—	■
Password protection	—	■	■
Memory			
SD card for logs and programming database (GB)	—	4	4
Onboard capacitor to power clock chip during power outage (days)	—	10	10

① Refer to driver/ballast manufacturer specs to calculate maximum connected load.

② Connects to controller MLAN network.

③ Requires PRCLOS configuration software.

④ Maximum of seven PRCEAEM (PRC1000E maximum one PRCEAEM) connected to MLAN network.

⑤ Connects to controller RS-485 CNET network.

⑥ Maximum of eight meters with Modbus RTU communications.

⑦ Requires industry standard ethernet patch cable.

External Mounted Controllers



External Mounted Controller

External mounted controllers are available for retrofit and renovation projects when existing panelboards do not have required controller mounting space. External mounted controllers include controller and control power transformer mounted in a NEMA 1 enclosure. Eaton Pow-R-Line 1a and 2a lighting panelboards can be converted to Pow-R-Command Expansion Panelboards (PRCEP) in the field by mounting Breaker Control Bus (BCB) and controllable circuit breakers directly to the interior. External mounted controllers are connected to the retrofitted PRCEP panelboard using the SLAN sub-net network communications.

Table 23.1-3. External Mounted Controllers

Controller Type	Connected System Voltage	Catalog Number
PRC750E with display	120 Vac	PRC750EECD-120
PRC750E with display	277 Vac	PRC750EECD-277
PRC2000E with display	120 Vac	PRC2000EECD-120
PRC2000E with display	277 Vac	PRC2000EECD-277

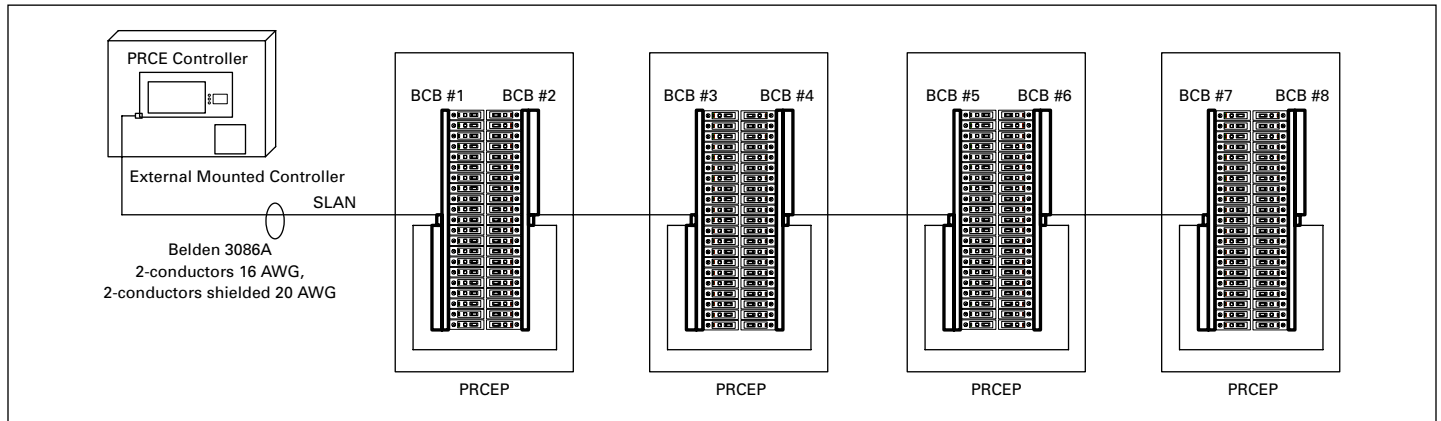

Figure 23.1-2. External Mounted Controller SLAN Connection to Expansion Panelboards

Note: For PRCE-SLAN-External Cabinet standard drawing references, visit Eaton.com/lightingcontrol.

Breaker Control Bus



Breaker Control Bus

Breaker Control Bus (BCB) provides the electronic interface and power switching signal between the controller and solenoid-operated controllable circuit breaker. Each controller can be connected to a maximum of eight BCBs. Each BCB is connected to the controller by connecting SLAN sub-net network. BCB are installed and tested at the factory. Length of BCB is selected by the factory to fit the size of lighting panelboard being used.

- Available in 9-, 15- and 21-circuit lengths to match lighting panelboard configuration
- DIP switches to configure device SLAN sub-net network address between 1 and 8
- RUN, SLAN and PWR LEDs indicated operating status
- Factory mounted to panelboard interior rails and tested
- Breaker Control Bus (BCB) mounted
 - Dual side
 - Left side only or right side only
 - Requires controlled loads to be located on the same side as BCB
 - Reduces cost of installed equipment
- Field installs into existing Pow-R-Line 1a and 2a lighting panelboards

Table 23.1-4. Breaker Control Bus

Description	Controlled Circuits	Catalog Number
9-circuit breaker control bus	9	PRCBCB9R
15-circuit breaker control bus	15	PRCBCB15R
21-circuit breaker control bus	21	PRCBCB21R

Controllable Circuit Breakers

Single- and two-pole solenoid operated controllable circuit breakers provide branch circuit protection and control of connected loads. Controllable circuit breakers are for electrical distribution systems up to 480Y/277 Vac. Controllable circuit breakers include status flag and temporary mechanical override.

GHQRD Controllable Circuit Breakers



Table 23.1-5. GHQRD Controllable Circuit Breakers ①

Number of Poles	Ampere Rating	Interrupting Capacity (Symmetrical Amperes) Vac (50/60 Hz)				Catalog Number
		120	120/240	277	277/480	
1	15	65,000	65,000	14,000	—	GHQRD1015
	20	65,000	65,000	14,000	—	GHQRD1020
	30	65,000	65,000	14,000	—	GHQRD1030
2	15	65,000	65,000	—	14,000	GHQRD2015
	20	65,000	65,000	—	14,000	GHQRD2020
	30	65,000	65,000	—	14,000	GHQRD2030

① Not recommended for existing PRC25, PRC100, PRC750, PRC1000 and PRC2000 systems. GHQRSP controllable circuit breakers are compatible with these systems.

GHORDEL Emergency Controllable Circuit Breakers

GHORDEL controllable circuit breakers are designed to meet NEC 700.12(F) for sources of power in unit equipment used for emergency lighting applications.

Pow-R-Command GHORDEL emergency lighting controllable circuit breaker is a simple low-cost device used to switch emergency lighting off when the space is unoccupied while maintaining power to the emergency detection circuit. This two-pole controllable circuit breaker includes a solenoid operated controllable pole and manually operated pole. Circuit breaker features also include handle-tie for common disconnect and internal common trip mechanism. GHORDEL includes one phase connection to comply with the 2010 National Electrical Code; Section 700.12(F) for Sources of Power utilized in emergency lighting applications.



Emergency Circuit Breaker

Table 23.1-6. GHORDEL Emergency Circuit Breaker ①

Number of Poles	Ampere Rating	Interrupting Capacity (Symmetrical Amperes) Vac (50/60 Hz)		Catalog Number
		277	277/480	
2	15	14,000	—	GHORDEL2015 GHORDEL2020
	20	14,000	—	

① Refer to **Page 23.1-27** for typical field wiring drawing.

BABRSP Controllable Circuit Breakers



Single-Pole

Two-Pole

Table 23.1-7. BABRSP

Number of Poles	Ampere Rating	Interrupting Capacity (Symmetrical Amperes) Vac (50/60 Hz)		Catalog Number
		120	120/240	
1	15	10,000	—	BABRSP1015 BABRSP1020 BABRSP1030
	20	10,000	—	
	30	10,000	—	
2	15	—	10,000	BABRSP2015 BABRSP2020 BABRSP2030 BABRSP2040 BABRSP2050
	20	—	10,000	
	30	—	10,000	
	40	—	10,000	
	50	—	10,000	

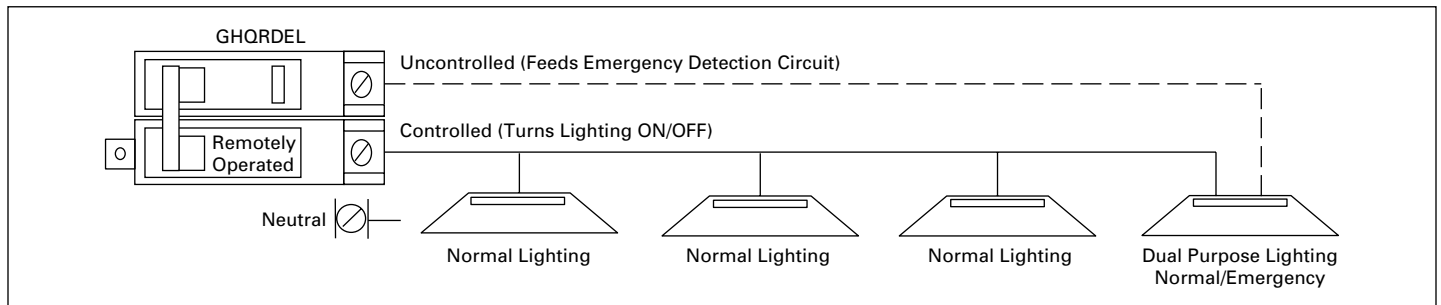

Figure 23.1-3. Emergency Lighting Control Using GHORDEL Emergency Controllable Circuit Breaker

Master Panelboard

Pow-R-Command Intelligent Panelboards are assembled in two basic configurations: Master Panelboard and Expansion Panelboard. Pow-R-Command systems are scalable using both Master and Expansion Panelboards to provide the right amount of control with reduced installed cost and system complexity.

Master Panelboards are designed for standalone and networked systems. Master Panelboard components include:

- PRC-E controller
- Low-voltage power supply
- Breaker Control Bus (BCB) mounted
 - Dual side
 - Left side only or right side only
 - Requires controlled loads to be located on the same side as BCB
 - Reduces installed equipment cost
- Factory-installed SLAN cables
- Solenoid-operated controllable circuit breakers
- Option to add standard circuit breakers
- Option to add commonly used panelboard accessories, i.e., metering and surge protection devices

Note: For PRCE-SLAN standard drawing references, visit Eaton.com/lightingcontrol.

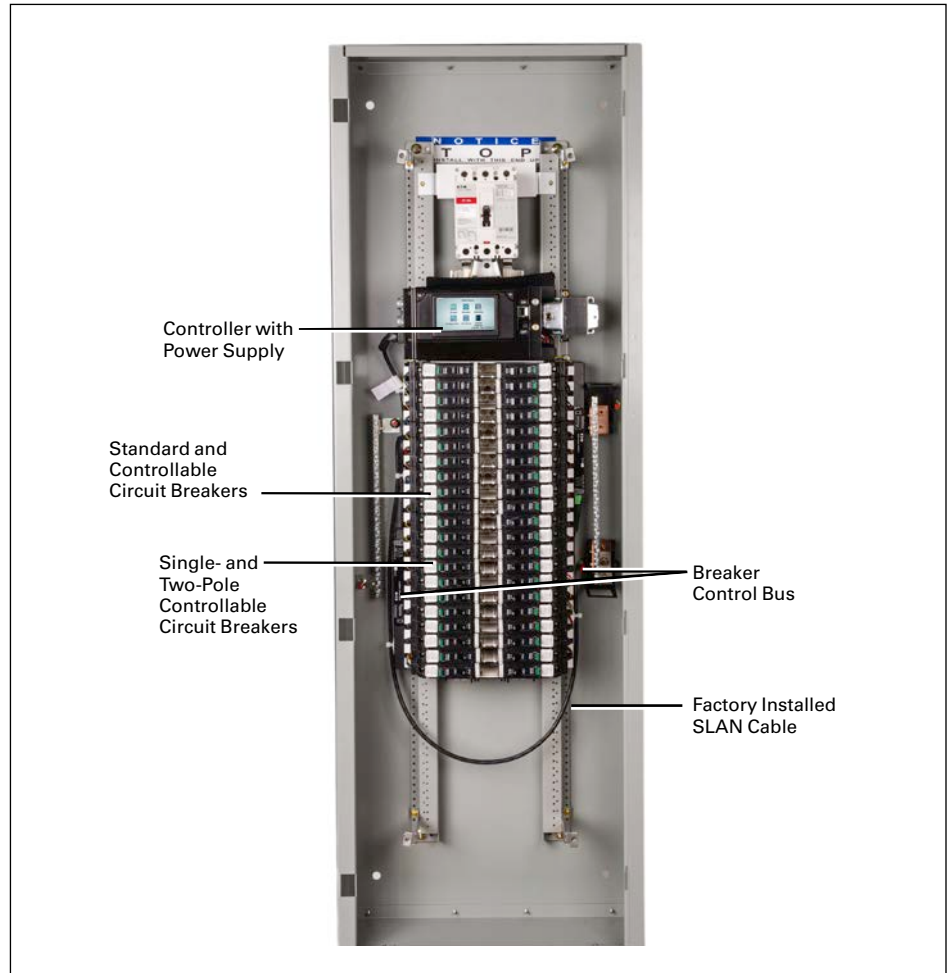

Figure 23.1-4. Master Panelboard

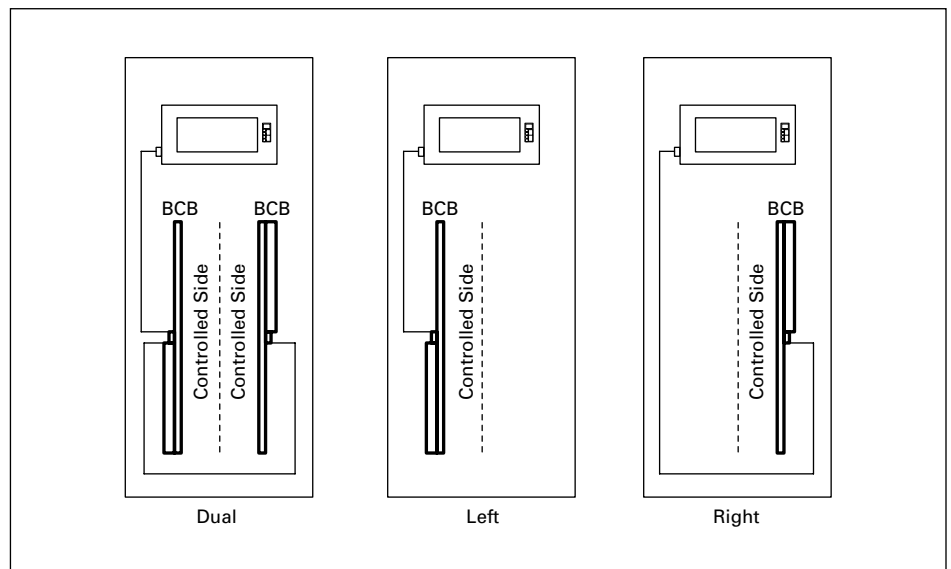

Figure 23.1-5. Master Panelboard BCB Configurations

Expansion Panelboard

Expansion Panelboards (PRCEP) are designed to directly connect to Master Panelboard via controller SLAN sub-net network. Expansion Panelboard components include:

- Breaker Control Bus (BCB)
 - Dual side
 - Left side only or right side only
 - Requires controlled loads to be located on the same side as BCB
 - Reduces cost of installed equipment
- Factory-installed SLAN cables
- Solenoid-operated controllable circuit breakers
- Option to add standard circuit breakers
- Option to add commonly used panelboard accessories, i.e., metering and surge protection devices

Note: For PRCE-SLAN standard drawing references, visit Eaton.com/lightingcontrol.

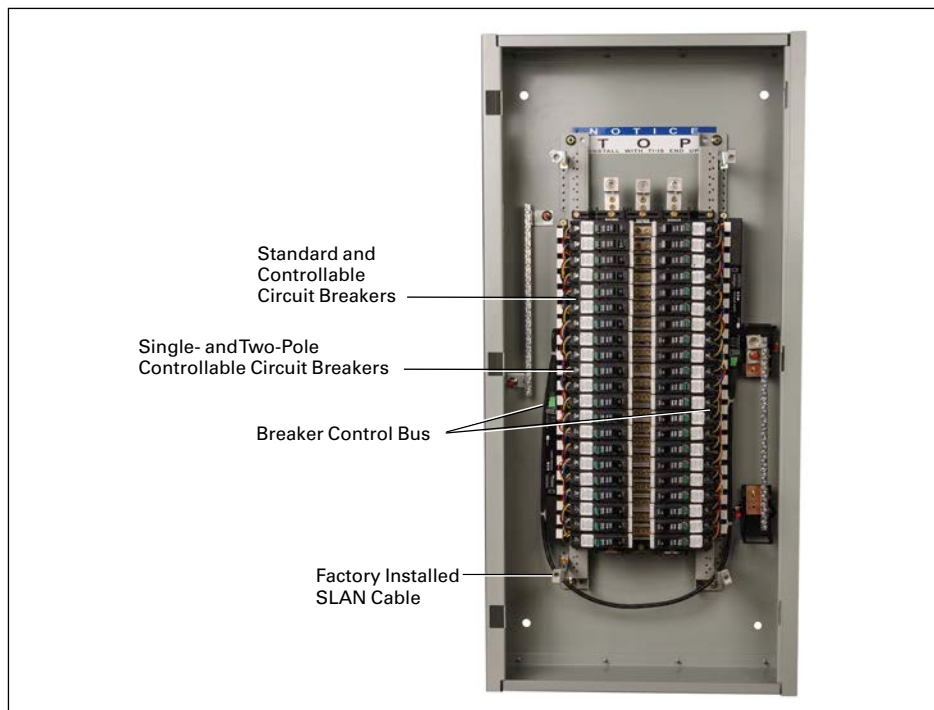

Figure 23.1-6. Expansion Panelboard

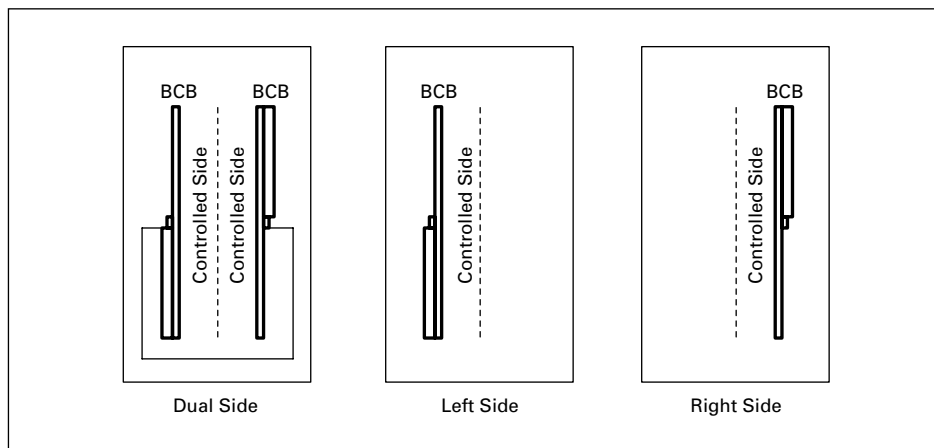

Figure 23.1-7. Expansion Panelboard BCB Configurations

Powered Expansion Panelboard

Powered Expansion Panelboards (PRCEPP) are designed to directly connect to Master Panelboard via controller SLAN sub-net network when the distance between the Master Panelboard and Expansion Panelboard exceeds 150 ft. Powered Expansion Panelboard components include:

- Low-voltage power supply
- Breaker Control Bus (BCB)
 - Dual side
 - Requires controlled loads to be located on the same side as BCB
 - Reduces cost of installed equipment
- Factory-installed SLAN cables
- Use Belden 3105A shielded twisted pair cable to connect controller to Powered Expansion Panelboard BCB
- Solenoid-operated controllable circuit breakers
- Option to add standard circuit breakers
- Option to add commonly used panelboard accessories, i.e., metering and surge protection devices

Powered Expansion Panelboards can be field converted to a Master Panelboard by installing the controller.

Note: For PRCE-SLAN standard drawing references, visit Eaton.com/lightingcontrol.

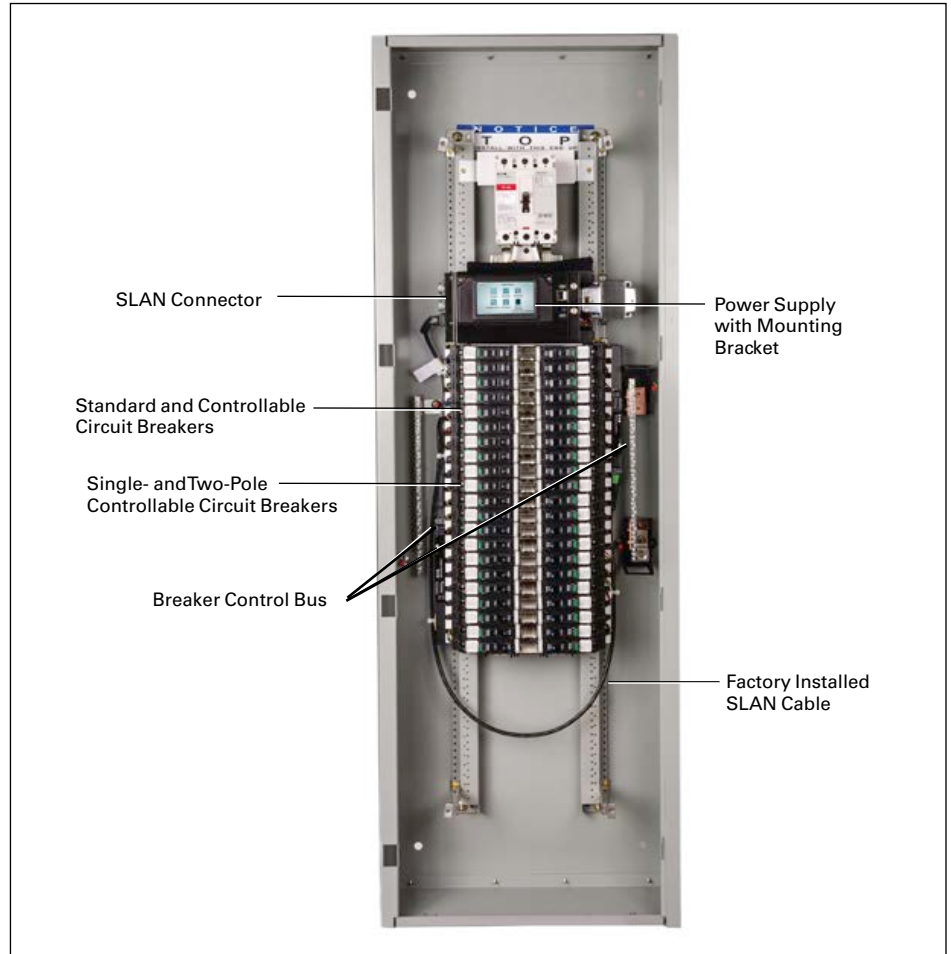

Figure 23.1-8. Powered Expansion Panelboard

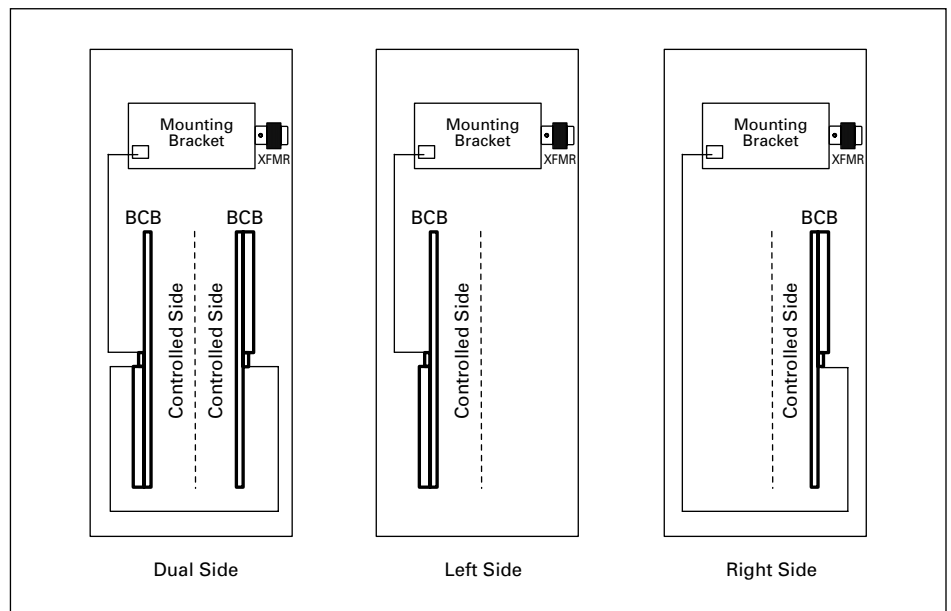

Figure 23.1-9. Powered Expansion Panelboard BCB Configurations

Master Panelboard to Expansion Panelboard SLAN Sub-Net Network

SLAN sub-net network is used to connect a single PRC-E controller to a maximum of eight Breaker Control Buses (BCB). The SLAN carries command signals from the controller to the appropriate BCB, which in turn, switches the solenoid-operated circuit breaker. Through the SLAN, the controller also polls BCB for status of the solenoid-operated circuit breakers. In addition to providing the communications path to the BCB, the SLAN wiring also provides a 30Vac from the control power transformer for powering the BCB and providing power to switch the solenoid-operated circuit breakers.

- SLAN connections
 - SLAN+ and SLAN- communications connections
 - Power and Common power connections
- SLAN cable is specified ALPHA 1064, 600 V, 16 AWG, 4 conductors
- Panelboard internal SLAN cables are factory installed
- Fiber-optic cable is recommended for outdoor, underground or between-structure applications



Figure 23.1-10. Controller SLAN Connector

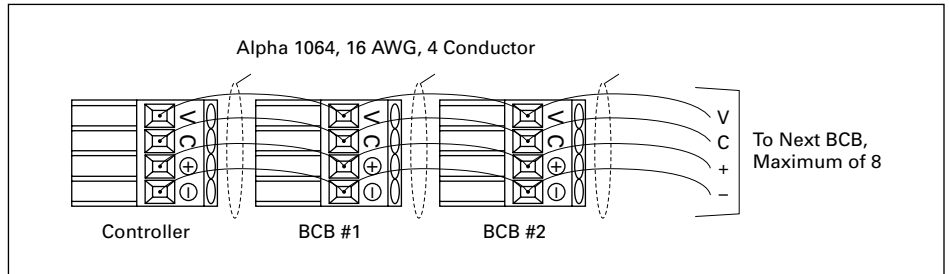

Figure 23.1-11. Breaker Control Bus-to-Breaker Control Bus Wiring



Figure 23.1-12. Breaker Control Bus SLAN Connector

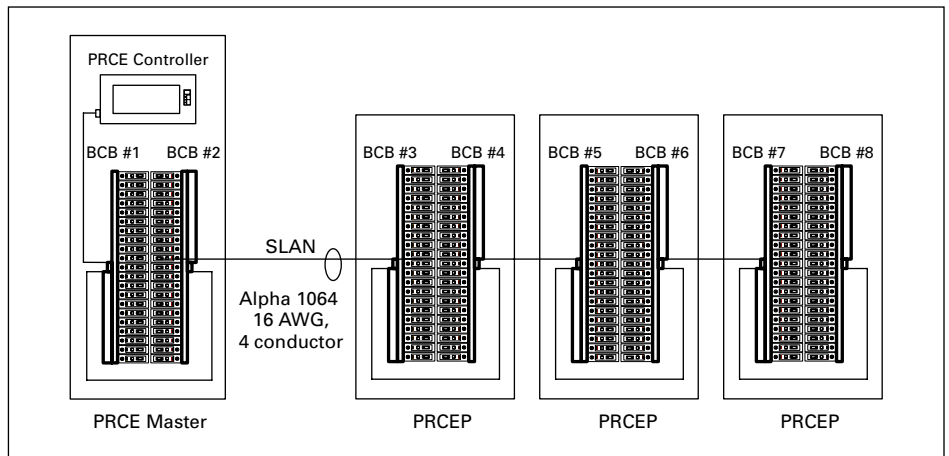

Figure 23.1-13. PRC Master/Expansion Panelboards SLAN

Note: For PRC-SLAN standard drawing references, visit Eaton.com/lightingcontrol.

Ethernet Networks

PRC2000E controllers include ethernet network communications capabilities providing remote programming, monitoring and override functions. Using the Pow-R-Command peer-to-peer communications protocol, each controller connected to the ethernet network can transmit and receive messages among the connected controllers. PRC750E controller is intended for standalone control and does not include Ethernet communications.

- PRC2000E controller provides remote access to preconfigured web pages to program, monitor and override the system over ethernet network connection
- Fiber-optic cable is recommended for outdoor, underground or between-structure applications

Note: For PRCE-ethernet standard drawing references, visit Eaton.com/lightingcontrol.

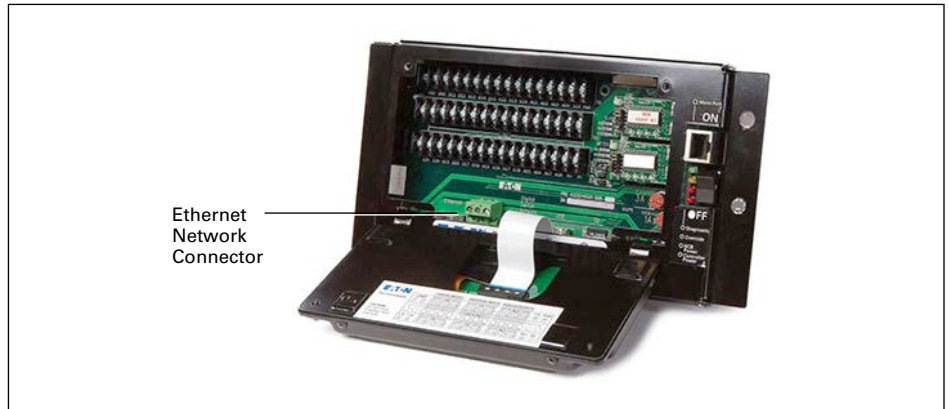

Figure 23.1-14. Controller Ethernet Network Connection

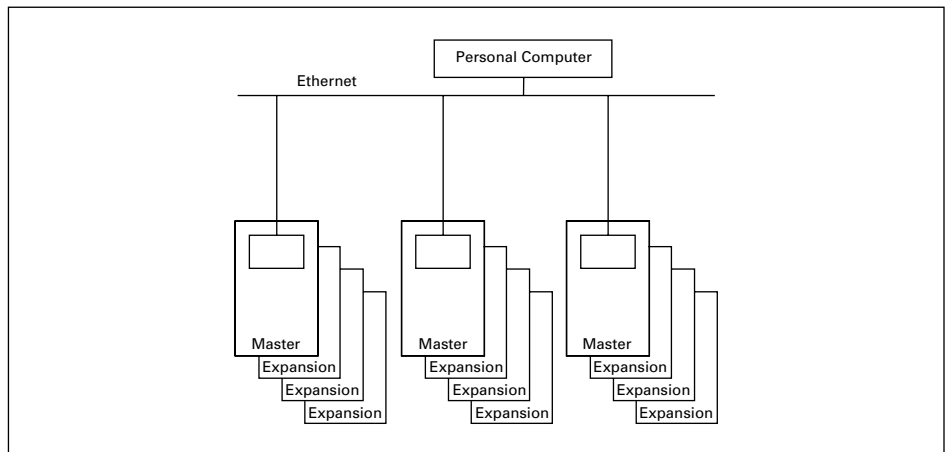

Figure 23.1-15. Remote Communications Over Ethernet Network

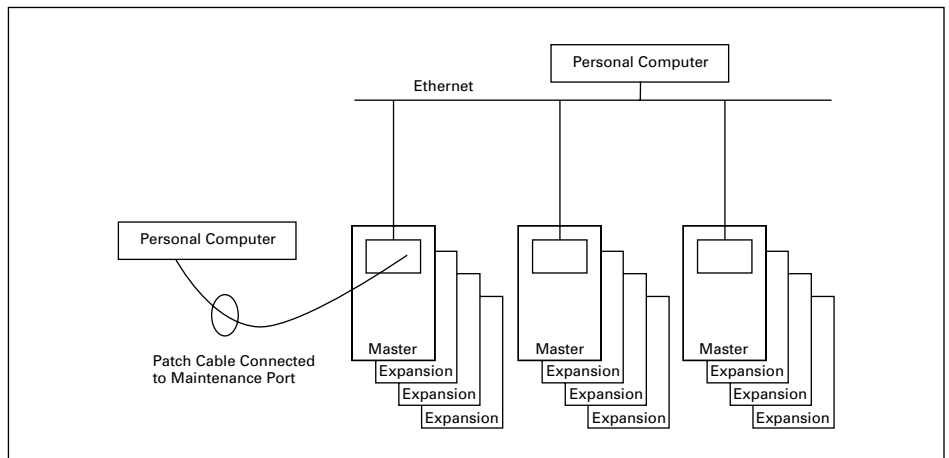

Figure 23.1-16. Front Panel Connection to Ethernet Network

MLAN Networks

PRC2000E controllers include MLAN RS-485 communications network for connecting a maximum of seven Analog Expansion Modules (PRCEAEM). Additionally, a maximum of eight meters equipped with Modbus RTU communications can be connected. MLAN is not available in PRC750E controllers.

- Connect maximum of seven Analog Expansion Modules
- PRC750E is not equipped with MLAN
- Connect maximum of eight metering devices equipped with Modbus RTU communications (PRC2000E only), ModbusTCP pass-through mode implemented for providing metering information upon request from metering and monitoring systems
- Requires daisy-chain network architecture
- Requires Belden 3105A shielded twisted pair communications cable
- Maximum 4000 ft network length
- Network status available through controller web pages
- Refer to **Page 23.1-23** for Analog Expansion Module information
- Refer to **Page 23.1-37** and **Page 23.1-38** for mains and branch circuit metering information

Note: For MLAN network typical drawing references, visit Eaton.com/lightingcontrol.



Figure 23.1-17. Controller MLAN RS-485 Network Connection

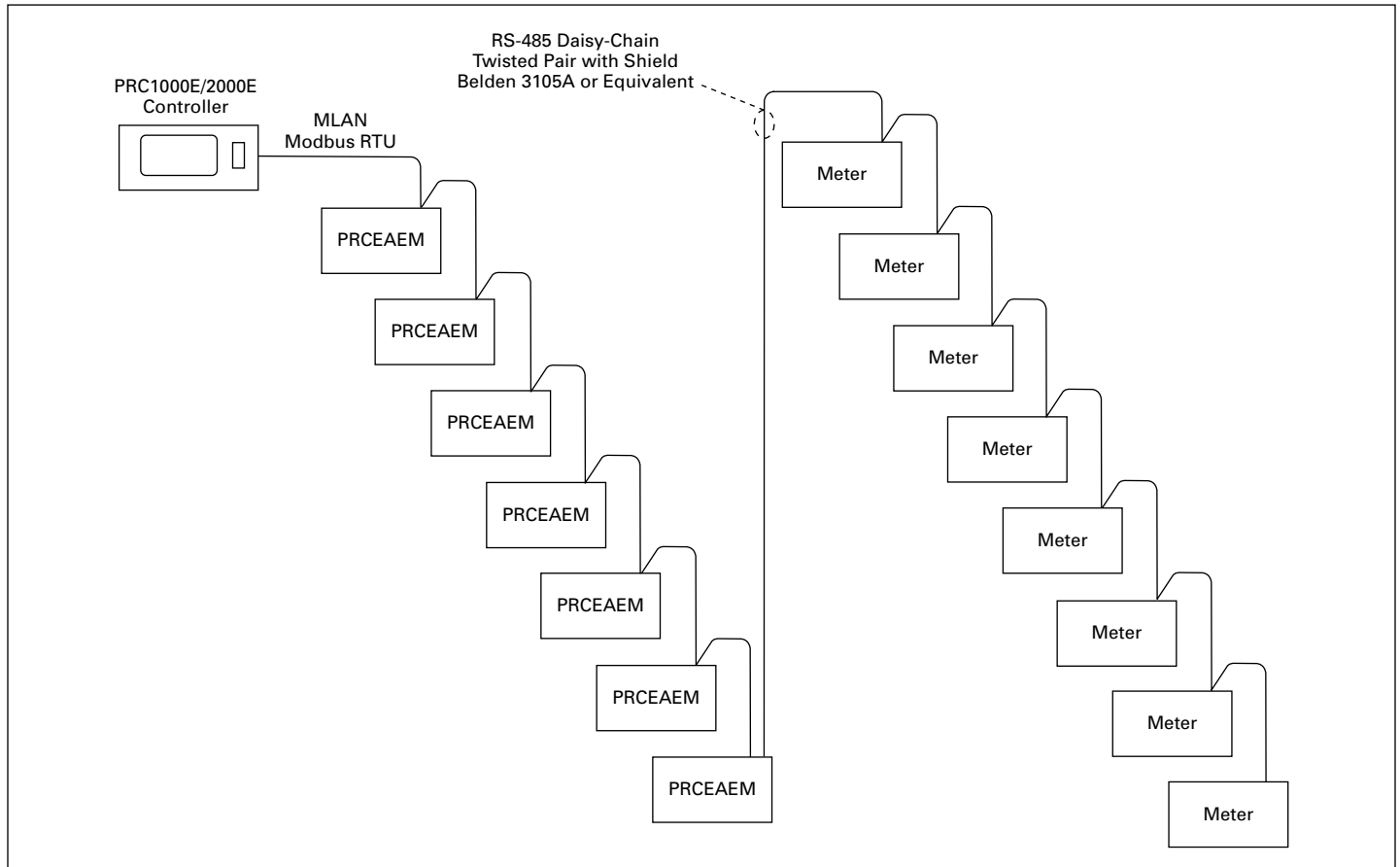

Figure 23.1-18. Controller MLAN RS-485 Network

Digital Network Switches



Digital Switches

General Description

Pow-R-Command Digital Switches (PRCDS) and Low-Voltage Switches (PRCLS) provide local occupant override and light level scene control. Switches are available in 2-, 4- and 6-button configurations in white, black, almond and ivory colors. Switches are compatible with decorator-type wall plates and comply with NEMA WD-1 standards and sized to fit minimum NEMA wall box width dimension.

Digital Switches (PRCDS)

Pow-R-Command Digital Switches are used for occupant override and light level control. These devices are connected to the controller Digital Switch Network (DSN). PRC2000E controllers include the DSN feature. PRCDS switches are not compatible with the PRC750E controller.

Digital Switch comes standard with onboard memory to store all configuration and programming. This allows for the DSN to have distributed intelligence. This keeps the DSN from having a centralized break point. If one Digital Switch were to fail, the integrity of the network would not be compromised, and the remaining Digital Switches would still function properly.

- Connect to controller Digital Switch Network (DSN) using CAT6 23 AWG cable
- Each PRCDS includes two RJ-45 connectors for connecting the PRCDS switch DSN using a daisy-chain network architecture
- Up to 99 Digital Switches can be connected to a controller DSN
- Onboard rotary switches allow addresses (01–99) to be set in the field
- LED backlit buttons provide real-time breakers and/or groups status
- Onboard digital and analog I/O
- Onboard 12 Vdc external power source
- 2-, 4- and 6-button configurations
- Black, white, almond and ivory colors
- Matching wallplates in single and multi-gang configurations

PRCDS switches include onboard digital and analog I/O plus an external device power source. Field wired devices like occupancy sensors and photosensors can be directly wired to the PRCDS switch to eliminate the need for running field wiring to the electric closet.

This feature saves installation time and provides lower installed system cost. Lighting equipped with 0–10 Vdc analog dimming control circuitry is also directly wired to the PRCDS switch. All ON/OFF and dimming control logic resides in the PRCDS switch.

- Analog input (AI) accepts 0–10 Vdc signal and is typically used to connect photosensor
- Digital input (DI) is typically used to connect occupancy sensor or other dry-contact input

Note: Not available on 6-button Digital Switch.

- Analog output (AO) is used to directly control lighting equipped with 0–10 Vdc dimming circuitry

Note: Maximum 10 mA current sink.

- 12 Vdc/20 mA output (VOUT) power devices, i.e., occupancy sensors and photosensors

Note: Higher than 20 mA current will disable operation of device.



Engraved Digital Switch
(6-button shown)

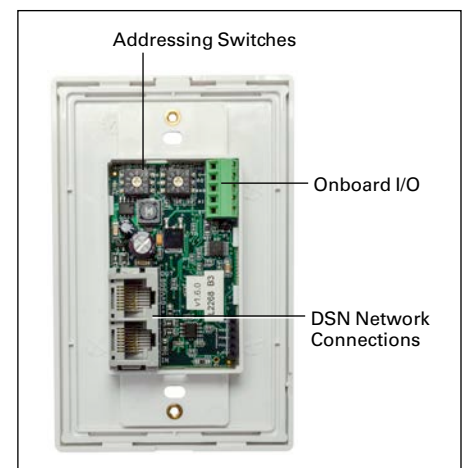

Figure 23.1-19. Digital Switch Hardware Overview

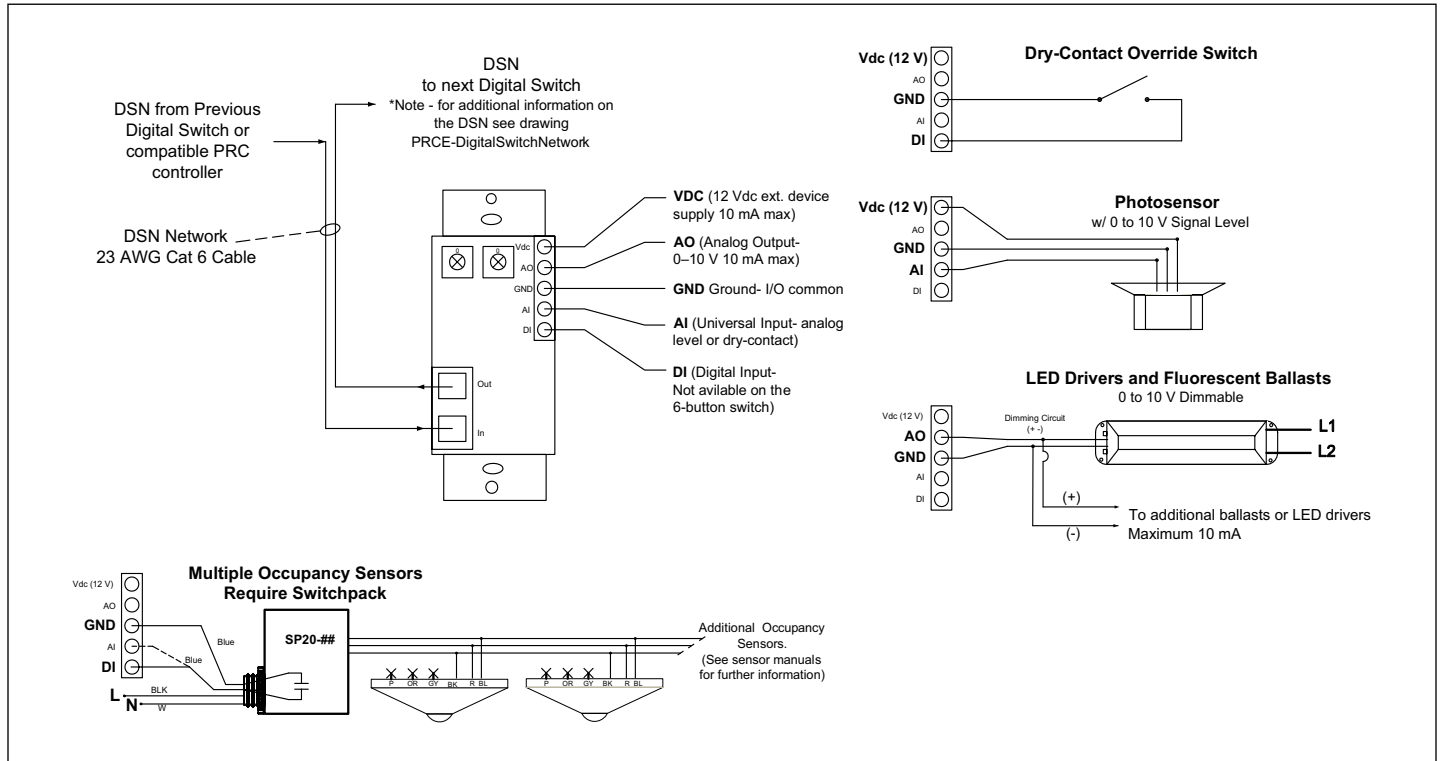

Figure 23.1-20. Digital Switch Analog and Digital I/O Typical Wiring

Table 23.1-8. Digital Switch Selection ①

Number of Buttons	Color	Catalog Number
2	Black	PRCDS2B
4	Black	PRCDS4B
6	Black	PRCDS6B
2	White	PRCDS2W
4	White	PRCDS4W
6	White	PRCDS6W
2	Almond	PRCDS2A
4	Almond	PRCDS4A
6	Almond	PRCDS6A
2	Ivory	PRCDS2V
4	Ivory	PRCDS4V
6	Ivory	PRCDS6V

① Consult factory for custom labeling.

Note: For Switch Wallplates, refer to Table 23.1-11.

Table 23.1-9. Digital Switch I/O Configuration

Pushbutton Configuration	Analog Input 0-10 Vdc	Digital Input 2-Wire Dry Contact	Analog Output 0-10 Vdc 10 mA Maximum	12 Vdc Output 10 mA Maximum
Two-button	■	■	■	■
Four-button	■	■	■	■
Six-button	■	—	■	■

Note: For PRCE-DigitalSwitch-IO standard drawing references, visit Eaton.com/lightingcontrol.

Digital Switch Network (DSN)

PRC2000E controllers include the Digital Switch Network (DSN) feature. Digital Switches (PRCDS) are connected to the DSN using the designated RJ-45 connector located in the controller low-voltage compartment using CAT6 23 AWG cable. All CAT6 connections are made using T-568B wiring standard to power the Digital Switch and establish communications with the controller.

Digital Switch Network requires adding a PRC Power Injector (PRCDSNPI) when more than 15 Digital Switches are connected or total DSN cable length exceeds 500 feet. Digital Switch Network Splitter (PRCDSNS) is required when more than 50 Digital Switches are connected to the DSN. PRCDSNS splitter can also be used to reduce DSN field wiring.

- Maximum of 99 digital switches are connected to controller DSN
- DSN daisy-chain network architecture is configured using CAT6 23 AWG
- Digital Switch Network Power Injector (PRCDSPI) is required when more than 15 devices are connected to the DSN or maximum network length exceeds 500 feet
- Digital Switch Network Splitter is required when more than 50 digital switches are connected or when network flexibility is needed

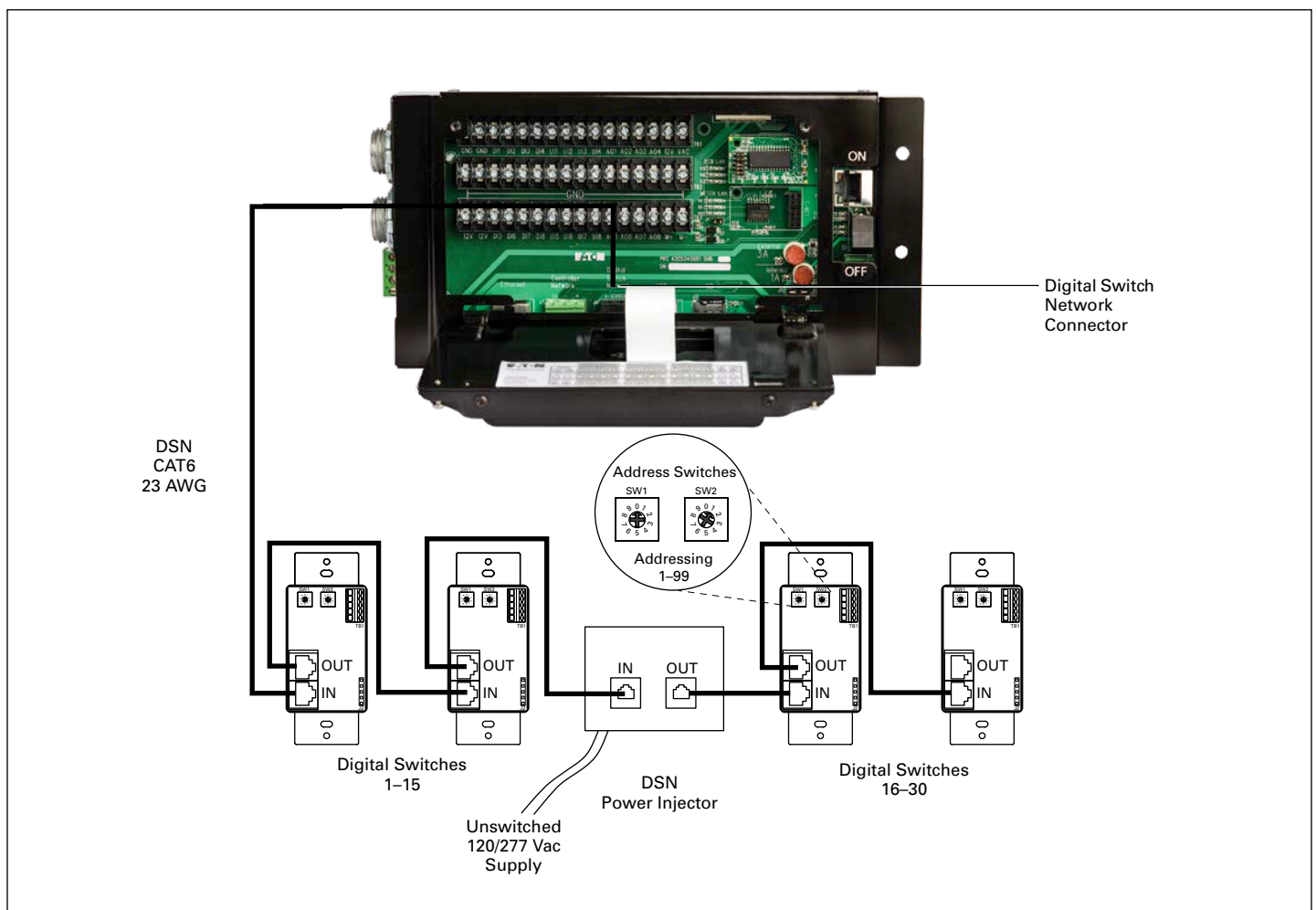

Figure 23.1-21. Typical Digital Switch Network (DSN)

Note: For PRCE-DigitalSwitchNetwork typical drawing references, visit Eaton.com/lightingcontrol.

Digital Switch Network Power Injector (PRCDSNPI) may be required due to the current draw requirements of each Digital Switch and connected field devices like occupancy/photo sensors and dimmable lighting equipped with 0–10 Vdc control circuitry, to operate correctly. The PRCDSNPI is required after each 15 PRCDS switches or when the DSN length exceeds 500 feet. DSN connections to the power injector are done in the exact same fashion as each Digital Switch. The PRCDSNPI includes a separate dual voltage 120/277 Vac power supply connection. Make sure to connect to an un-switched branch circuit.

- Used to boost low-voltage power on the DSN
- Required after each 15 digital switches are connected or when DSN exceeds 500 ft
- Includes 120/277 Vac power supply for connecting to un-switched branch circuit



Digital Switch Network Power Injector (PRCDSNPI)

Digital Switch Network Splitter (PRCDSNSP) is used as a convenient way to split the DSN into two legs to span in two directions. If there are more than 50 Digital Switches connected to a controller, a splitter is recommended. Consult factory for applications that may require this device.

- Used to split DSN into two directions
- May reduce the overall length of CAT6 23 AWG cable and installed cost
- Required for DSN with 50 or more digital switches

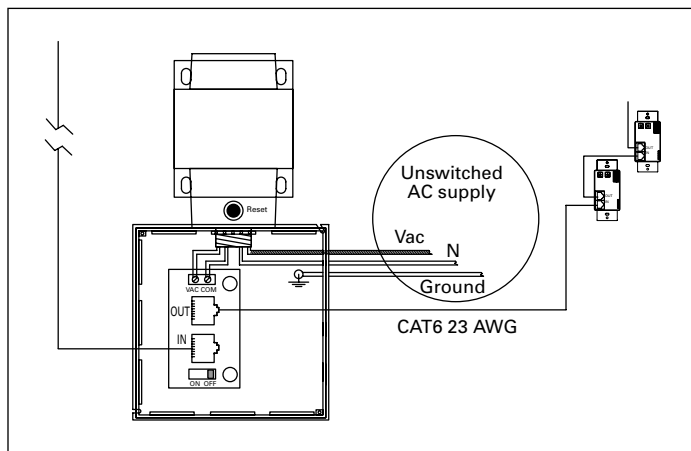

Figure 23.1-22. Digital Switch Network Power Injector Wiring



Digital Switch Network Splitter (PRCDSNSP)

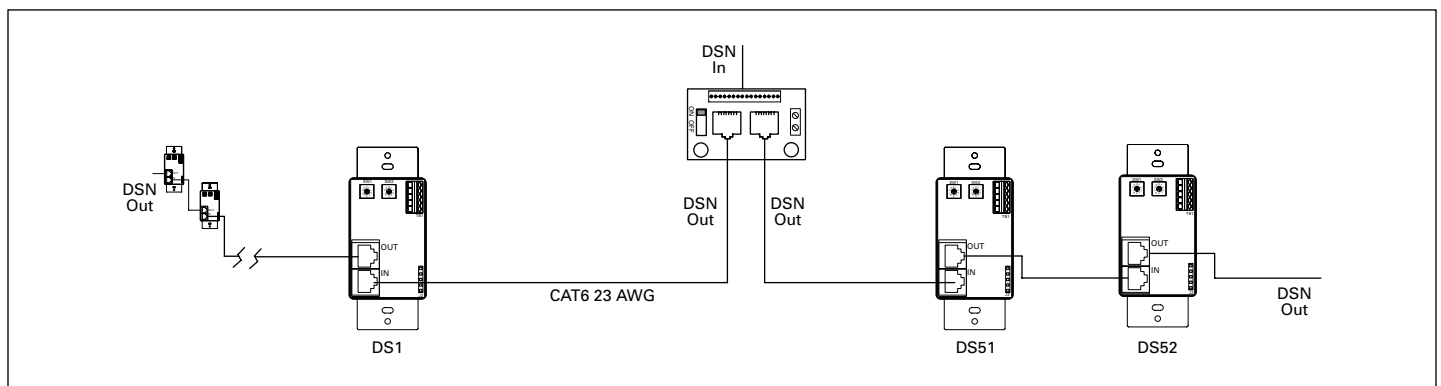

Figure 23.1-23. Digital Switch Network Splitter Wiring

Note: For PRCE-DigitalSwitchNetwork typical drawing references, visit Eaton.com/lightingcontrol.

Low-Voltage Switches (PRCLS)

Pow-R-Command low-voltage switches (PRCLS) are used for occupant override control. PRCLS switches are equipped with momentary dry-contact pushbuttons. These devices are connected to the controller digital inputs (DI1–DI8) and universal inputs (UI1–UI8). Pushbuttons do not include backlit feature. It is recommended that Digital Switches (PRCDS) be used for applications requiring backlit pushbuttons. Refer to Digital Switch information found on **Page 23.1-13**.

- Connect to controller digital inputs DI1–DI8 and universal inputs UI1–UI8 (PRC750E DI1–DI16) using 18 AWG wire, maximum of 500 ft
- 2-, 4- and 6-button configurations
- Black, white, almond and ivory colors
- Matching wallplates in single and multi-gang configurations



Low-Voltage Switch



Low-Voltage Switch Termination Board

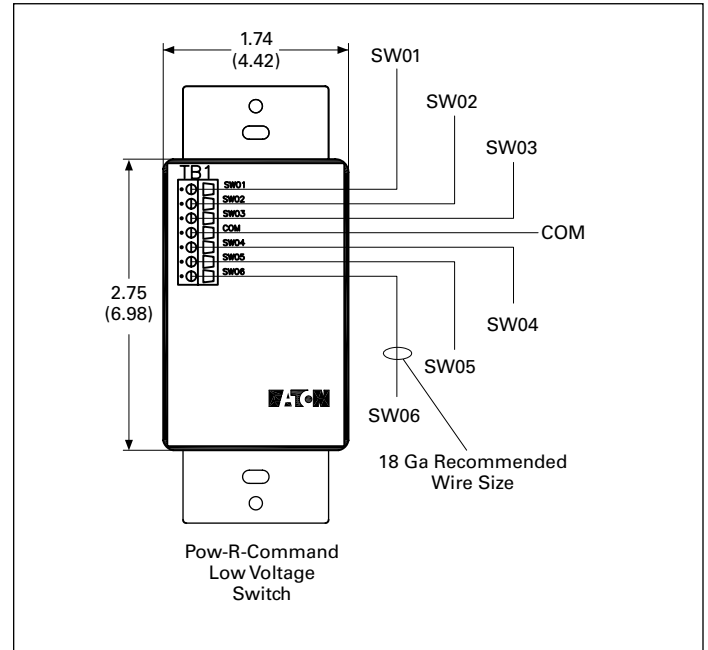

Figure 23.1-24. Low-Voltage Switch Connections

Table 23.1-10. Low-Voltage Switch Selection ①

Color	Number of Buttons	Catalog Number
Black	2	PRCLS2B
	4	PRCLS4B
	6	PRCLS6B
White	2	PRCLS2W
	4	PRCLS4W
	6	PRCLS6W
Almond	2	PRCLS2A
	4	PRCLS4A
	6	PRCLS6A
Ivory	2	PRCLS2V
	4	PRCLS4V
	6	PRCLS6V

① Consult factory for custom labeling.

Note: For Switch Wallplates, refer to **Table 23.1-11**.

Note: For PRCE-Input/Output standard typical references, visit Eaton.com/lightingcontrol.

Switch Wallplates (PRCSWP)

Pow-R-Command Switch Wallplates fit Digital Switch (PRCDS) and Low-Voltage Switch (PRCLS) devices. Screwless design provides easy installation. Available in black, white, almond and ivory for single and multi-gang designs.



Switch Wallplate

Table 23.1-11. Switch Wallplate Selection

Color	Number of Switches	Catalog Number
Black	1	PRCSWP1B
	2	PRCSWP2B
	3	PRCSWP3B
White	1	PRCSWP1W
	2	PRCSWP2W
	3	PRCSWP3W
Almond	1	PRCSWP1A
	2	PRCSWP2A
	3	PRCSWP3A
Ivory	1	PRCSWP1V
	2	PRCSWP2V
	3	PRCSWP3V

Field control devices are connected to the controller digital inputs, analog inputs and analog outputs located in the low-voltage compartment found behind the display. Easy access to these connections is accomplished by loosening the two captive screws found on each of the display top corners. Once screws are loosened, the display can be folded down using the hinge connection.

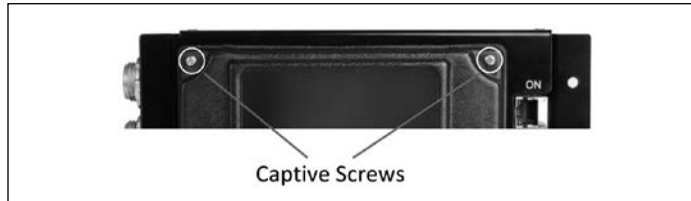

Figure 23.1-25. Controller Class 2 Low-Voltage Compartment Access

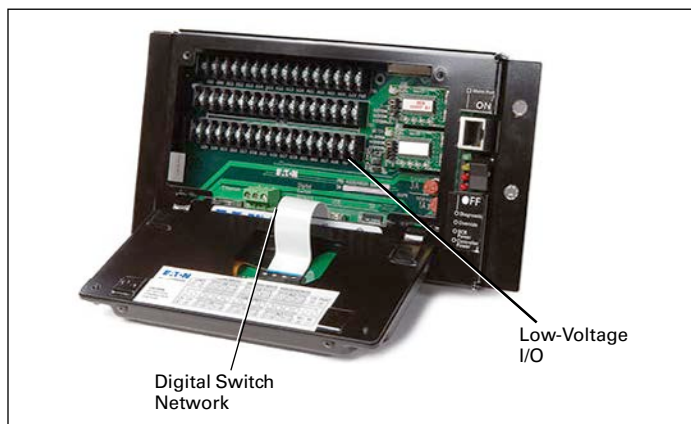

Figure 23.1-26. Controller Class 2 Low-Voltage Compartment

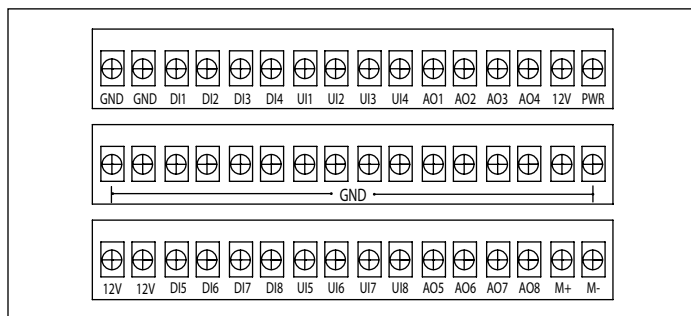

Figure 23.1-27. Low-Voltage Wiring Connections

Digital Inputs

PRC2000E controllers are equipped with eight digital inputs (DI1–DI8) and eight universal inputs (UI1–UI8). Universal inputs are configured as digital inputs when more than eight digital switch groups are required.

Note: PRC750E controller includes 16 digital inputs DI1–DI16, no universal inputs.

Digital inputs are designed for connecting low-voltage momentary or maintained inputs and other devices equipped with dry-contact outputs, i.e., photo controllers, building management systems and security systems.

- Eight digital inputs (DI1–DI8)
- Eight universal inputs (UI1–UI8) configurable to digital inputs when more than eight digital switch groups are required
- Digital inputs are connected using 18 AWG wire
- Maximum distance 500 feet between controller and input device
- 12 Vac external power source used to power low-voltage devices, i.e., occupancy sensors
- PRC750E controller includes 16 digital inputs only (UI1–UI8 factory set to digital input configuration)

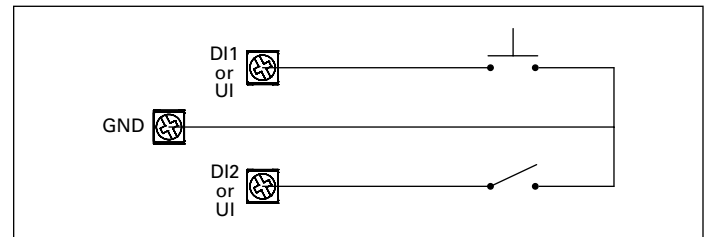

Figure 23.1-28. Maintained or Momentary Dry-Contact Input Connection

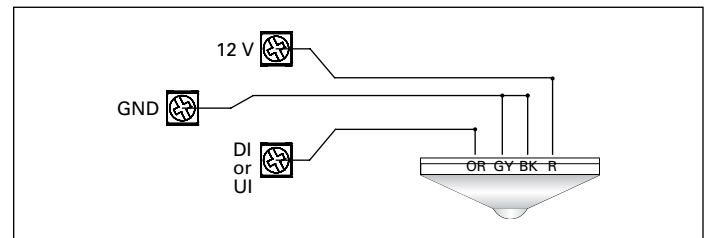

Figure 23.1-29. Low-Voltage Occupancy Sensor

Note: For PRCE-InputOutput standard drawing references, visit Eaton.com/lightingcontrol.

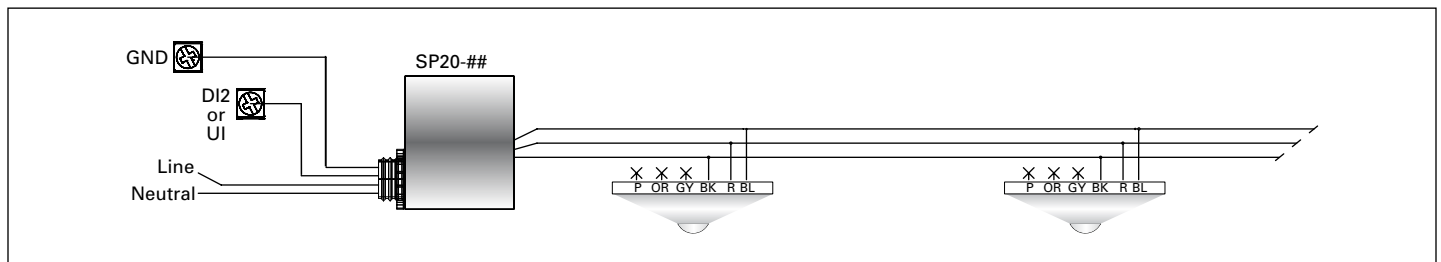

Figure 23.1-30. Multiple Low-Voltage Occupancy Sensors with Switchpack

Analog Inputs

PRC2000E controllers are equipped with eight universal inputs (UI1–UI8). Universal inputs are configured as 0–10 Vdc when analog light level sensors are used.

Note: PRC750E controller does not include universal inputs feature.

- Eight universal inputs configurable to 0–10 Vdc analog inputs (UI1–UI8)
- Universal inputs are connected using 18 AWG wire
- Maximum distance 500 ft between controller and input device
- 12 Vac external power source used to power low-voltage devices, i.e., photosensors
- It is recommended to use photosensors found in **Table 23.1-12**

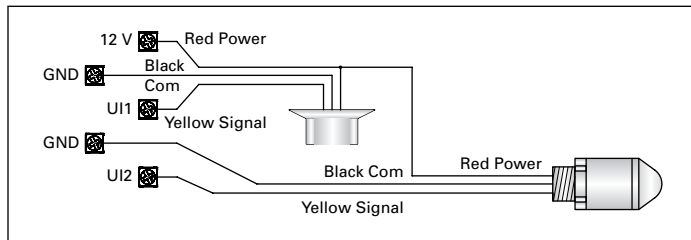

Figure 23.1-31. Photosensor Connection

Table 23.1-12. Photosensors

Description	Part Number
Indoor sensor— 12V input, 0–10V output, 70–750 fc	42C3977G01
Outdoor sensor— 12V input, 0–10V output, 50–750 fc	42C3977G02
Atrium sensor— 12V input, 0–10V output, 200–2500 fc	42C3977G03
Skylight sensor— 12V input, 0–10V output, 1000–7500 fc	42C3977G07

Analog Outputs

PRC2000E controllers are equipped with eight analog outputs (AO1–AO8). Analog outputs provide 0–10 Vdc connection and control of lighting equipped with 0–10 Vdc dimming control circuitry.

Note: PRC750E controller does not include analog outputs.

- Eight 0–10 Vdc analog outputs (AO1–AO8)
- Analog outputs are connected using 18 AWG wire
- Maximum of 80 mA sink or 40 mA source
- Maximum distance 1000 feet between controller and luminaire

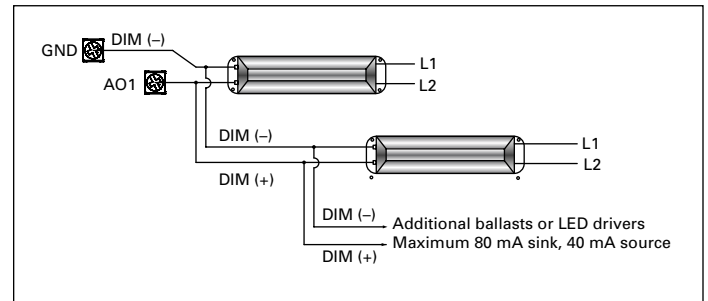

Figure 23.1-32. Analog Output Connection

Note: For PRCE-Input/Output standard drawing references, visit Eaton.com/lightingcontrol.

Analog I/O Expansion Module



Analog Expansion Module (PRCEAEM)

General Description

PRCE Analog Expansion Module (PRCEAEM) is used when the quantity of either analog inputs or analog outputs exceeds the controller maximum number of eight. Compatible with PRC2000E controller MLAN network. Not compatible with PRC750E controller. Each PRCEAEM includes eight 0–10 Vdc universal inputs and eight 0–10 Vdc analog outputs. Universal inputs can also be configured as maintained two-wire dry contact inputs for connecting external control devices. Analog outputs are used to connect LED and fluorescent lighting equipped with 0–10 Vdc dimming control circuitry. Maximum of 80 mA sink or source per analog output channel. PRCEAEM is connected to the controller MLAN network M+ and M– connections in a daisy-chain network architecture using Belden 3105A shielded twisted pair cable. It can be mounted near the controller or remotely to reduce field wiring. Maximum distance from the controller is 4000 ft. Maximum of seven PRCEAEMs can be connected to the controller MLAN network.

PRCEAEM is configured using Lighting Optimization Software (PRCLOS). Online status and I/O status is available through preconfigured web pages. Outputs can be overridden and taken out-of-service using preconfigured web pages. Device requires 12 Vdc regulated power source. Factory assembled with NEMA 1 enclosure controller, termination board and 120 Vac voltage power supply.

- Eight configurable universal inputs
 - Connect photosensors when configured as 0–10 Vdc analog inputs
 - Connect control devices equipped with maintained two-wire dry contact outputs
- Eight 0–10 Vdc analog outputs used to connect LED and fluorescent lighting equipped with 0–10 Vdc dimming circuitry
 - Maximum 80 mA sink or source
 - Maximum 1000 ft distance using 18 AWG cable
- 2-wire maintained inputs
- Maximum of seven PRCEAEM can be connected to the PRCE controller
 - Connect to controller MLAN network M+ and M– connections using a daisy-chain network architecture
 - Belden 3105A twisted pair with shield
 - Maximum 4000 ft distance from controller
- Configured using Lighting Optimization Software (PRCLOS)
- Online status and I/O status available through controller preconfigured web pages
- Requires 12 Vdc regulated power source
- Available in open style or in NEMA 1 enclosure (includes 120 Vac control power transformer)
- Not compatible with PRC750E controller

Table 23.1-13. PRCE Analog Expansion Module (PRCEAEM) Selection ①

Description	Catalog Number
Analog expansion module (open style)	PRCEAEM
One analog expansion module, NEMA 1 enclosure with 120 Vac power supply	PRCEAEM1E
Two analog expansion modules, NEMA 1 enclosure with 120 Vac power supply	PRCEAEM2E
Three analog expansion modules, NEMA 1 enclosure with 120 Vac power supply	PRCEAEM3E
Four analog expansion module, NEMA 1 enclosure with 120 Vac power supply	PRCEAEM4E

① Consult factory for non-standard configurations and enclosures.

Note: For PRCEAEM I/O connections and controller MLAN network connection typical drawing references, visit Eaton.com/lightingcontrol.

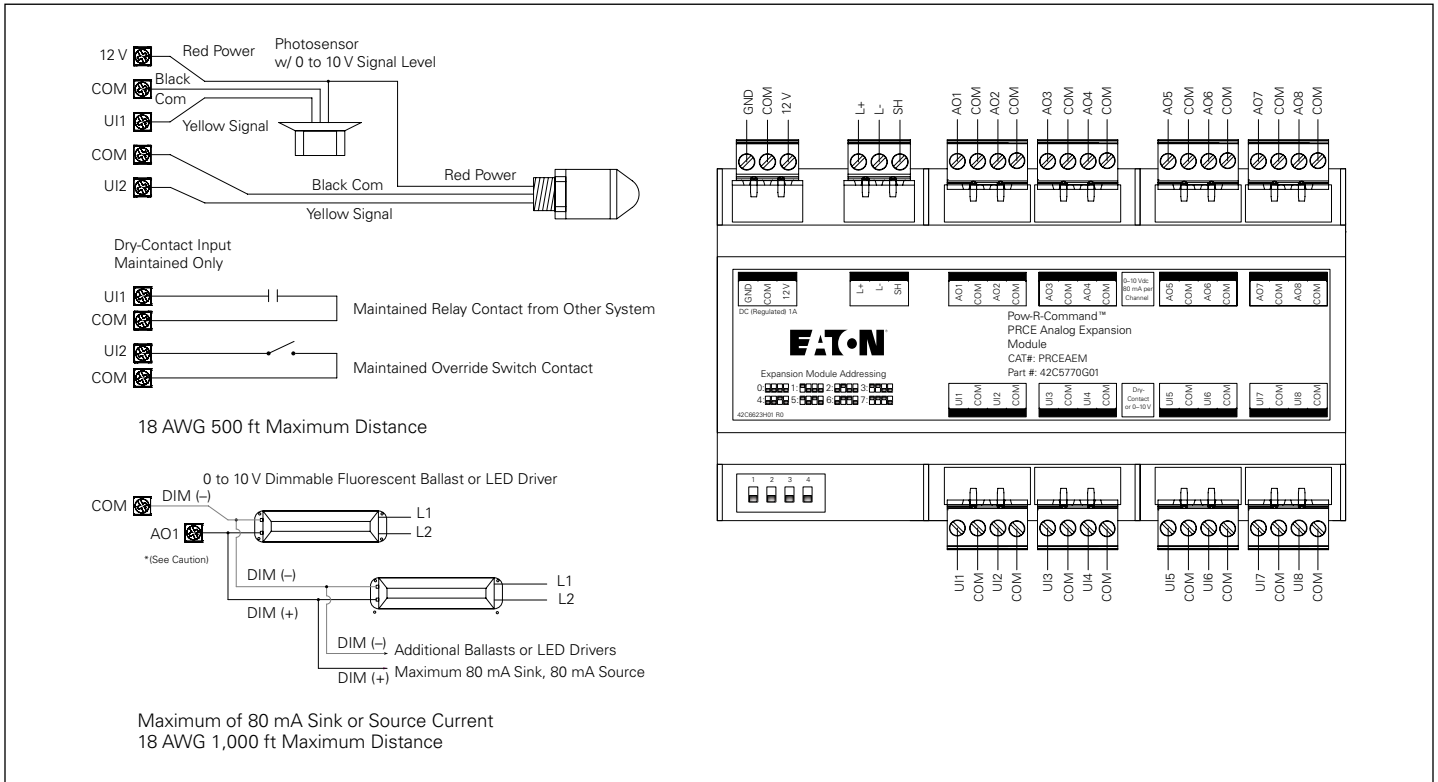

Figure 23.1-33. PRCE Analog Expansion Module I/O Connections

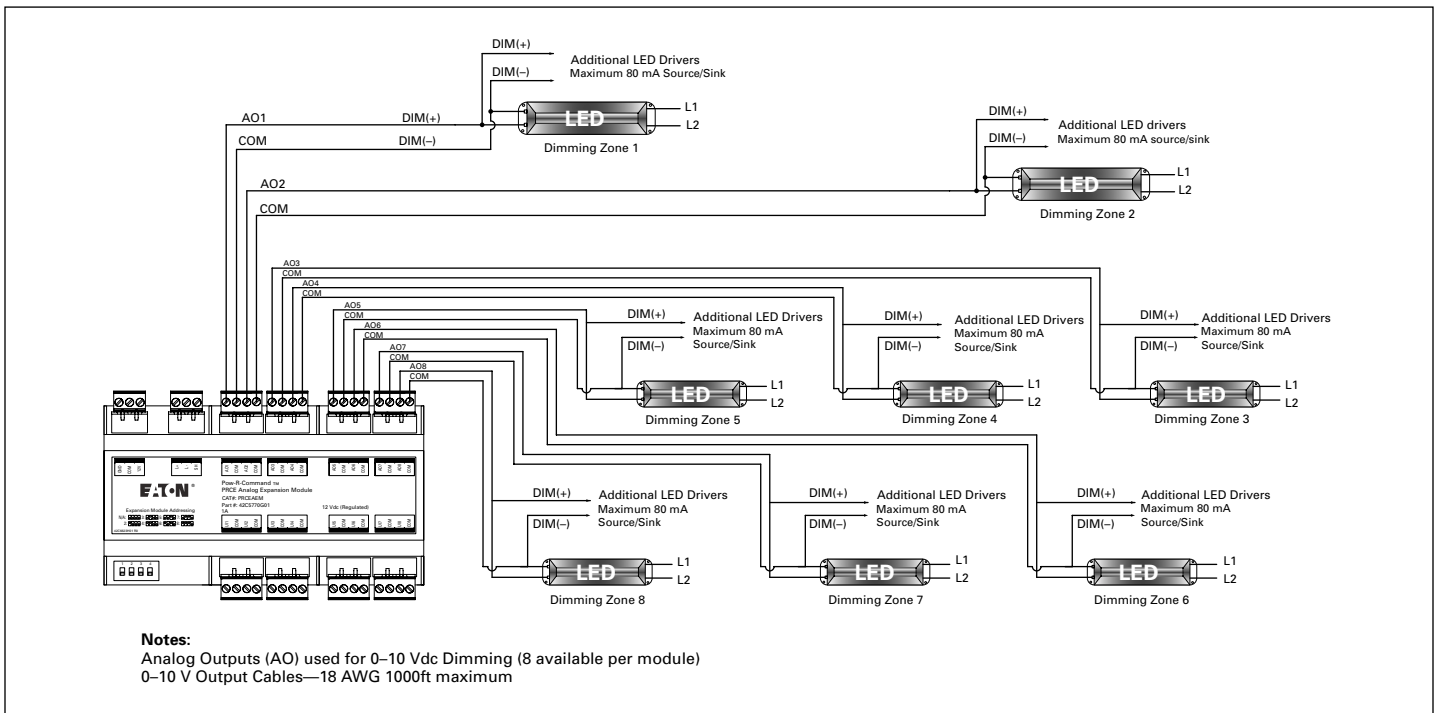

Figure 23.1-34. PRCE Analog Expansion Module 0–10 Vdc Dimming Outputs

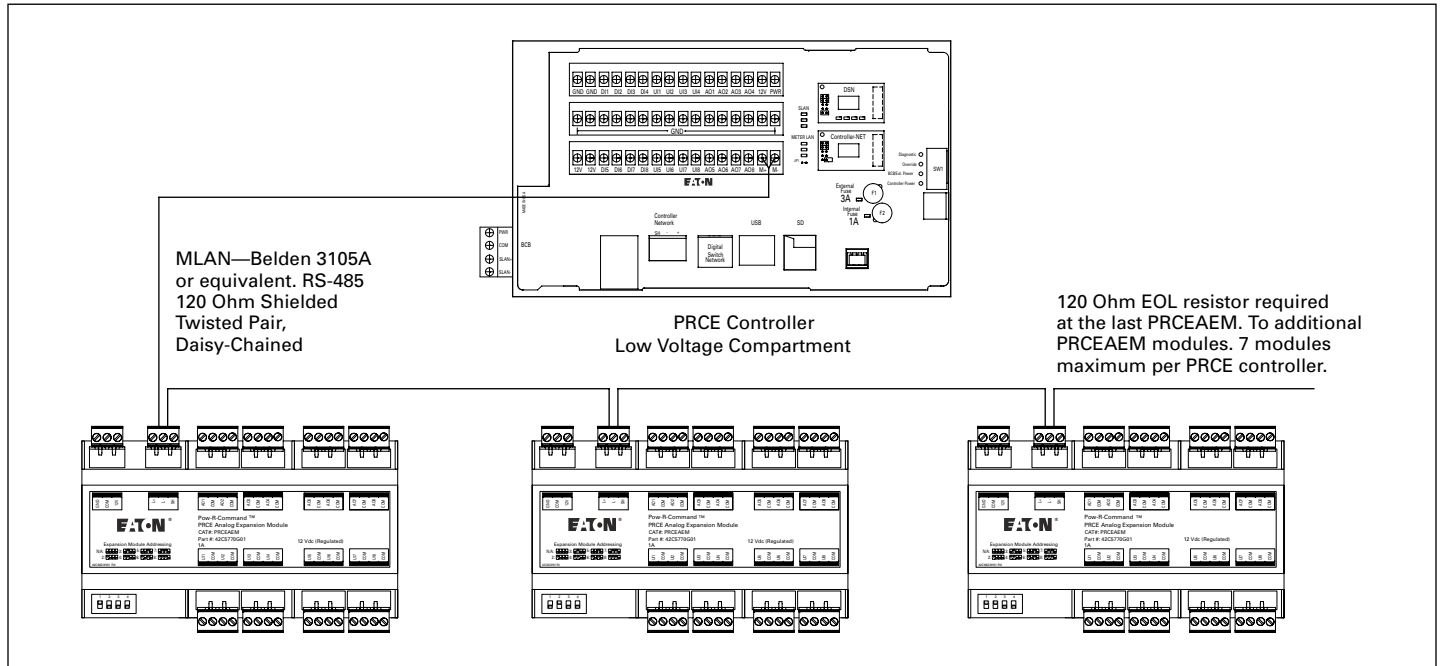

Figure 23.1-35. PRCE Analog Expansion Module Network, MLAN Network Connection

PRC5000E Master Controller



Enclosed PRC5000E Master Controller

Pow-R-Command 5000E controller (PRC5000E) is a microprocessor-based lighting and energy management controller. It is capable of communicating with other Pow-R-Command system devices for providing master scheduling control, load shedding and demand response, reporting, trend logging and implementing other control strategies.

PRC5000E controller is commonly used to serve facility custom graphics via web pages. Authorized users can log into the device using a standard web browser for viewing custom graphics. System schedule changes and override controls can be made at the click of a button.

Up to 15 individual local area networks (RS-485 serial network/CNET) can be coordinated through a single PRC5000E. Of these 15 networks, only one may be wired directly to the PRC5000E RS-485 CNET connector; the rest are connected via the facility's ethernet network. Each of these CNET networks can accommodate up to 120 Pow-R-Command devices.

- Master scheduler (250 schedules)
- Load shedding and demand response logic control
- System alarms
- Email notification
- Custom reports
- Controls up to 15 local area networks, each with maximum of 120 Pow-R-Command devices
- Two RS-485 local area network connections
- Ethernet port for remote access to local area networks
- Option to serve custom building graphics web pages
- Optional I/O includes: 7 digital inputs, 4 analog outputs, 4 digital outputs, 8 universal inputs
- Optional BACnet/IP communications
- Supplied in NEMA 1 enclosure with 120 Vac convenience outlet

Table 23.1-14. PRCE5000E Selection

Description	Catalog Number
Small Building Controller (web graphics) up to 20 CNET devices in enclosure	PRC5000ESE
Small Building Controller (web graphics) up to 20 CNET devices with I/O (7DO, 4AO, 4DI, 8UI) in enclosure	PRC5000ESIE
Small Building Controller (web graphics) up to 20 CNET devices with BACnet/IP in enclosure	PRC5000ESBE
Small Building Controller (web graphics) up to 20 CNET devices with I/O (7DO, 4AO, 4DI, 8UI) with BACnet/IP in enclosure	PRC5000ESIBE
Building Controller (web graphics) more than 20 CNET devices in enclosure	PRC5000EE
Building Controller (web graphics) more than 20 CNET devices with I/O (7DO, 4AO, 4DI, 8UI) in enclosure	PRC5000EIE
Building Controller (web graphics) more than 20 CNET devices with BACnet/IP in enclosure	PRC5000EBE
Building Controller (web graphics) more than 20 CNET devices with I/O (7DO, 4AO, 4DI, 8UI) with BACnet/IP in enclosure	PRC5000EIBE

Suffix	Feature
S	Small Building less than 20 devices
B	BACnet/IP
I	I/O (7DO, 4AO, 4DI, 8UI)
E	Enclosure

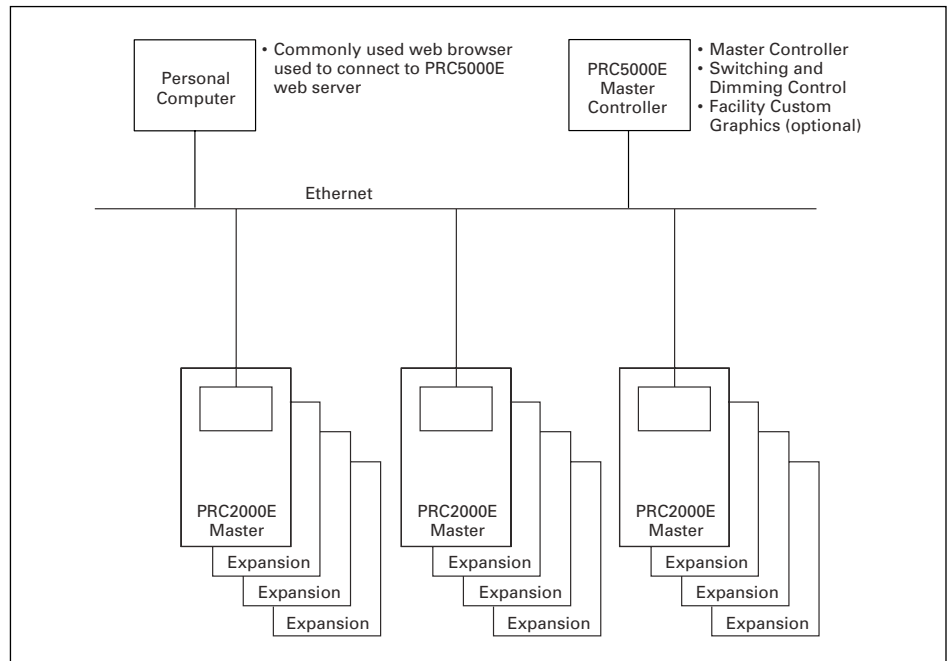

Figure 23.1-36. PRC5000E Master Controller

Note: For PRCE-Ethernet typical drawing references, visit Eaton.com/lightingcontrol.

Typical Electric Room Layout

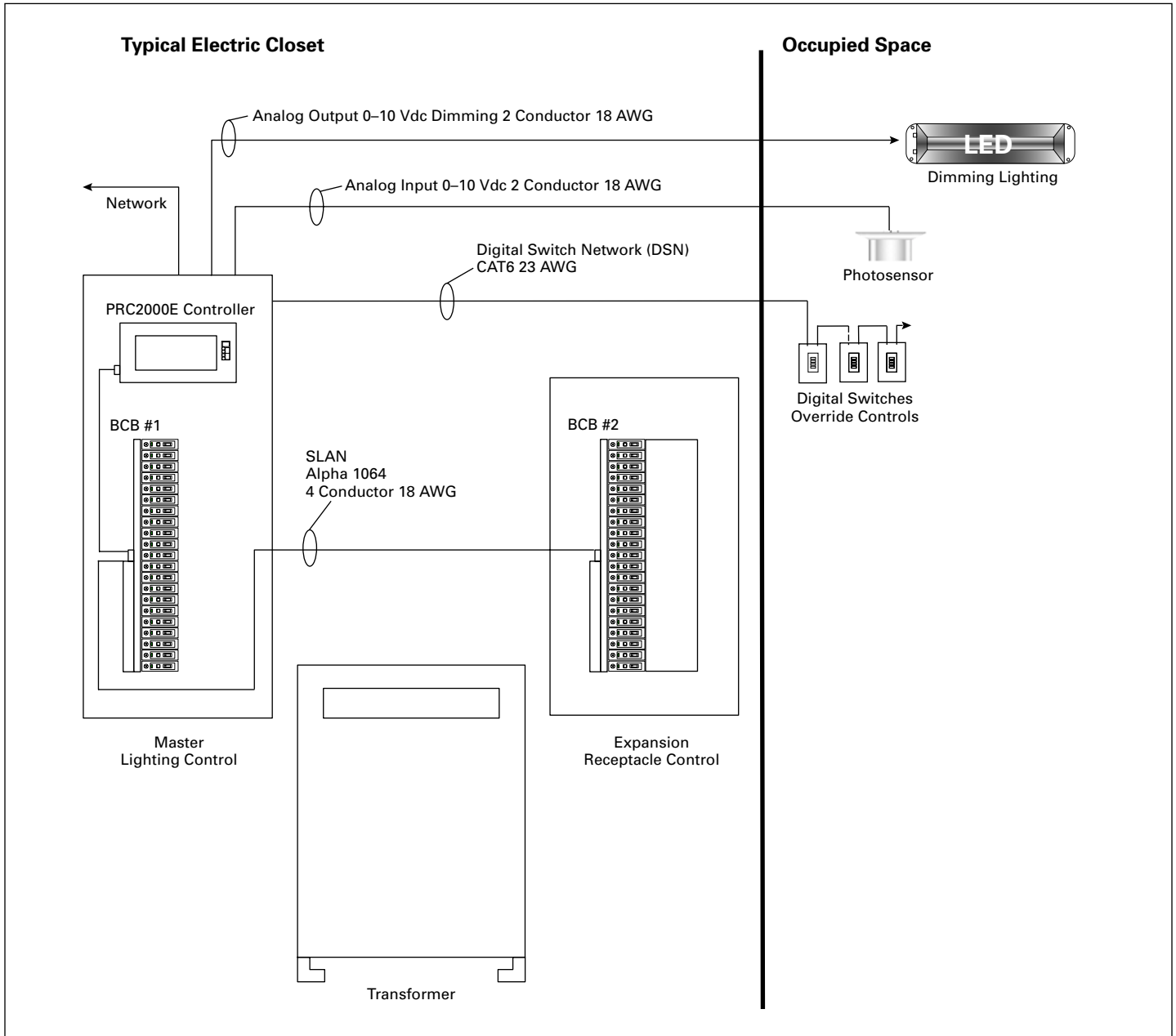

Figure 23.1-37. Typical Electric Room Layout

Multi-Story Building

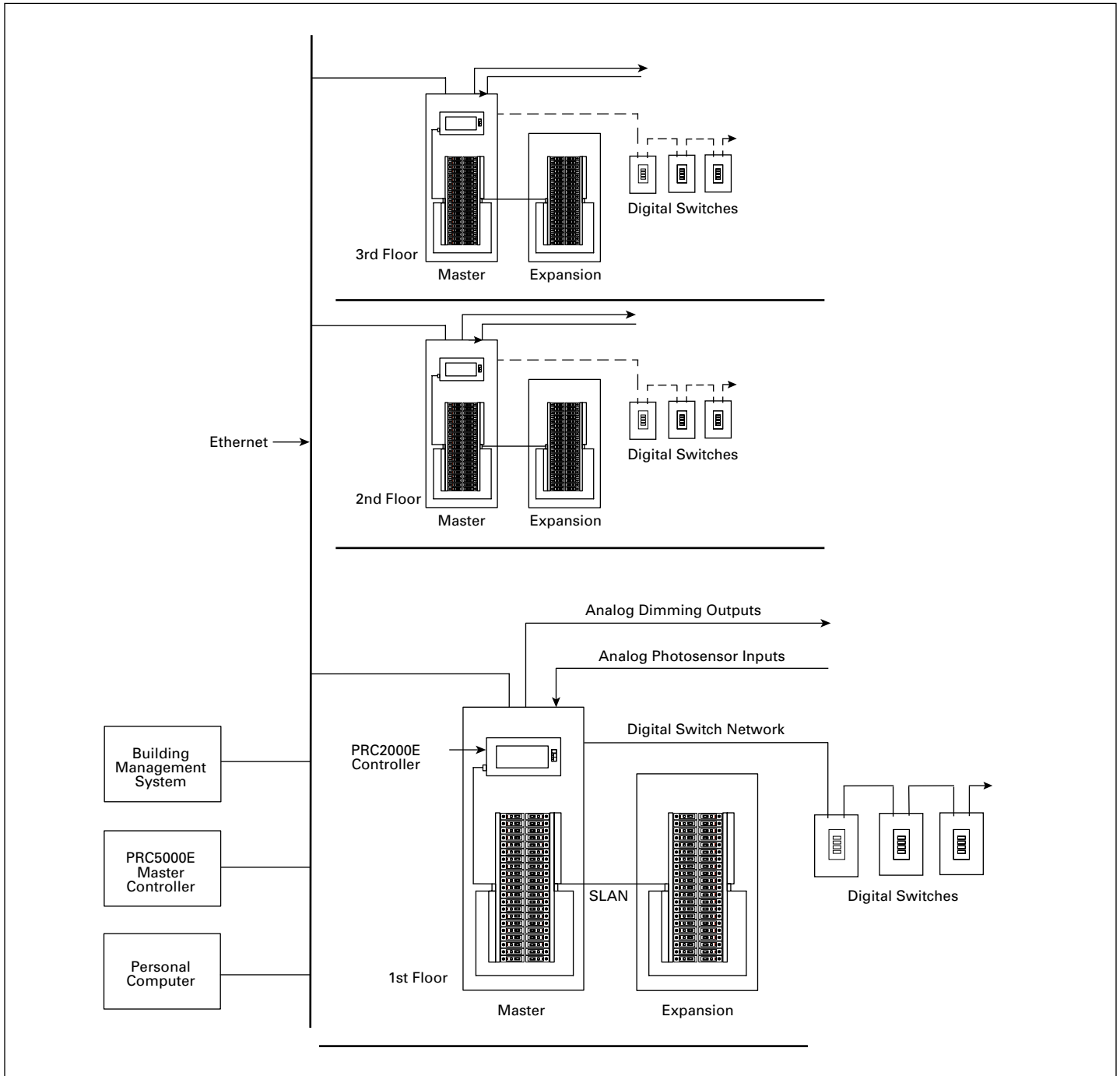

Figure 23.1-38. Multi-Story Building Layout

Note: For PRCE-Ethernet typical drawing references, visit Eaton.com/lightingcontrol.

Manual Occupant Light Level Dimming Control

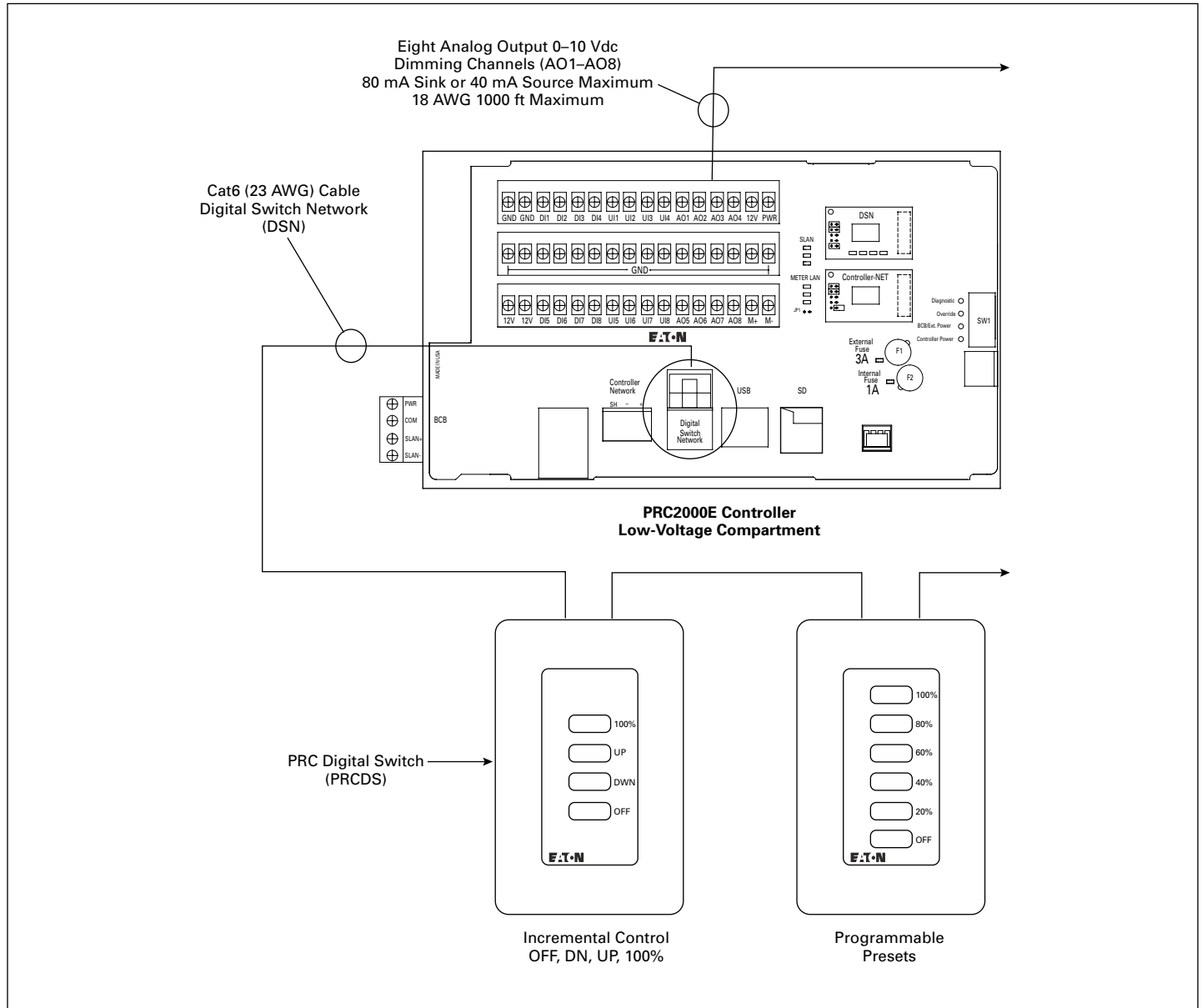

Figure 23.1-39. Manual Occupant Light Level Control

Note: For PRCE-Input/Output and PRCE-DigitalSwitch typical drawing references, visit Eaton.com/lightingcontrol.

Automatic Daylight Harvesting Dimming Control

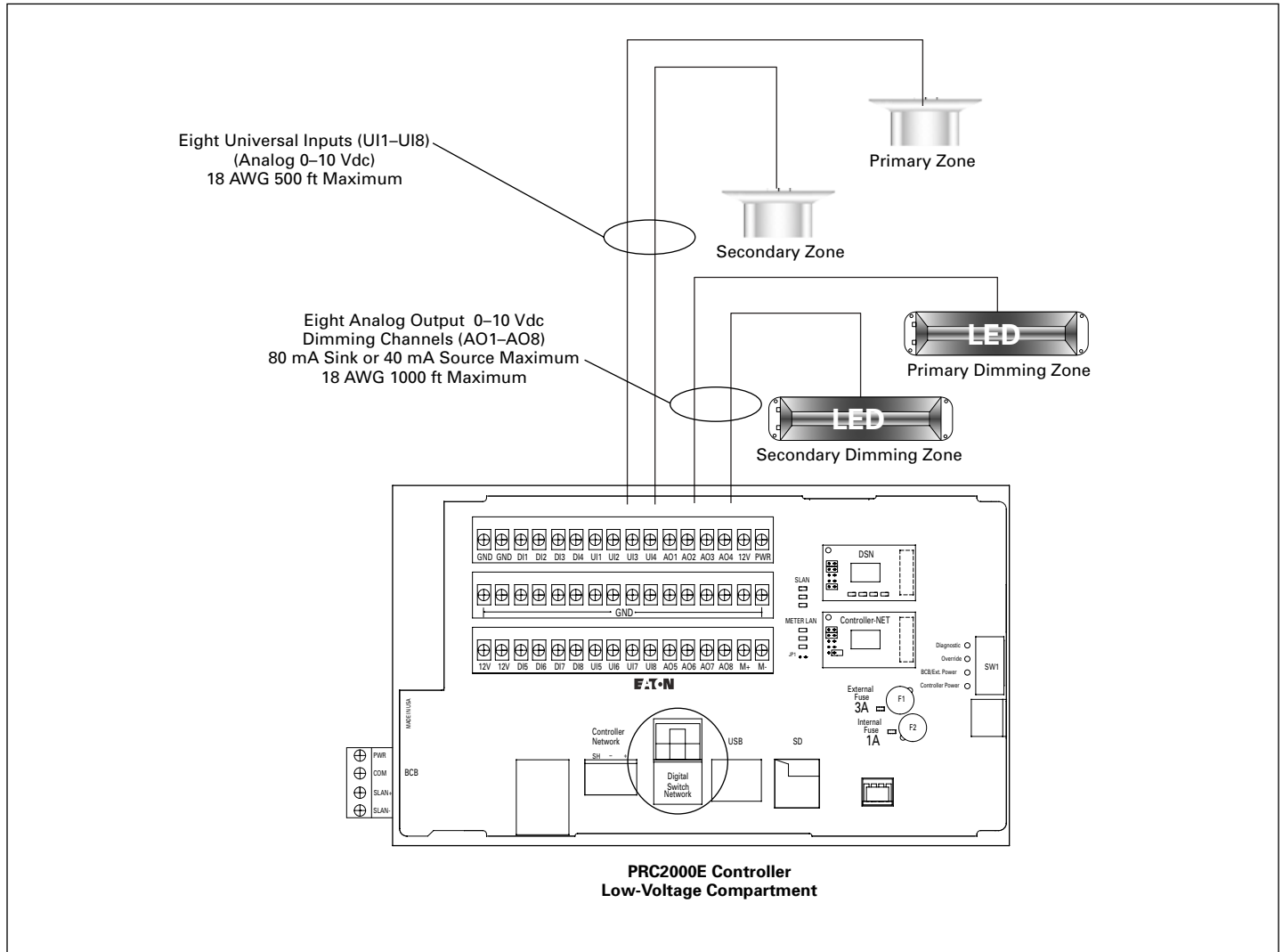

Figure 23.1-40. Automatic Daylight Harvesting Control

Note: For PRCE-Input/Output typical drawing references, visit Eaton.com/lightingcontrol. Analog Expansion Module (PRCEAEM) available when controller analog output 0–10 Vdc channels are exceeded. See **Page 23.1-23**.

Remote Mounted Analog Expansion Module

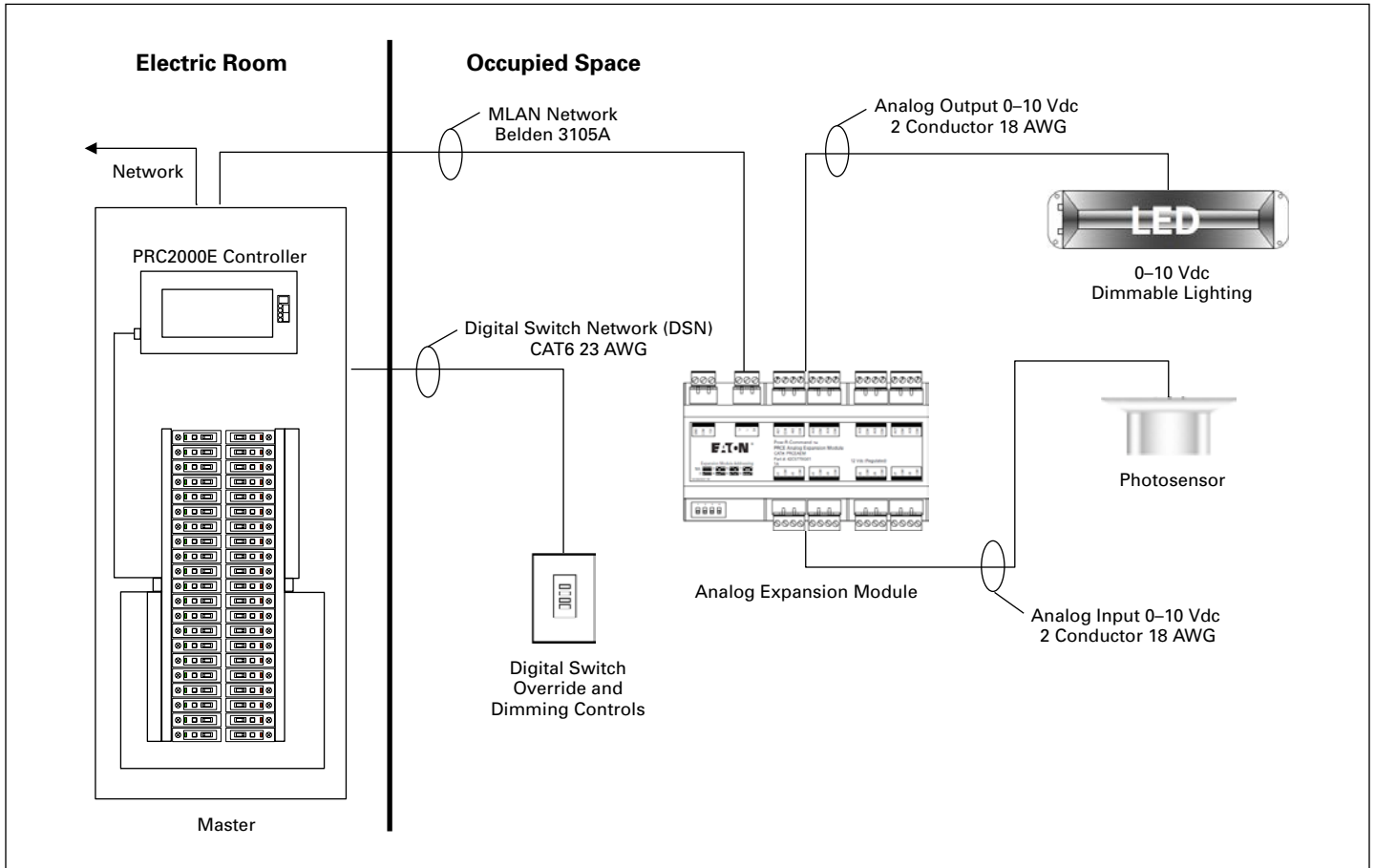

Figure 23.1-41. Remote Mounted Analog Expansion Module

Emergency Lighting Control



GHQRDEL Emergency Lighting Controllable Circuit Breaker

General Description

Emergency lighting control can be achieved by multiple methods. Commonly used methods include using an emergency lighting controllable circuit breaker, UL® 924 relay and UL 924 Uninterruptible Power Supply (UPS).

Pow-R-Command GHQRDEL emergency lighting controllable circuit breaker is a simple low cost device used to switch emergency lighting off when the space is unoccupied while maintaining power to the emergency detection circuit. This two-pole controllable circuit breaker includes a solenoid operated controllable pole and manually operated pole. Circuit breaker features also include handle-tie for common disconnect and internal common trip mechanism. GHQRDEL includes one phase connection to comply with the 2010 National Electrical Code; Section 700.12(F) for Sources of Power utilized in emergency lighting applications.

Features

GHQRDEL emergency lighting controllable circuit breaker features:

- Two-pole device with one phase connection to meet 2010 NEC Section 700(F) single source of power requirement
- Solenoid operated pole for switching lighting off when the space is unoccupied
- Manually operated pole to provide continuous power to emergency detection circuit
- Handle-tie provides common disconnecting means
- Internal common trip mechanism

Table 23.1-15. GHQRDEL Controllable Circuit Breakers ①

Number of Poles	Ampere Rating	Interrupting Capacity (Symmetrical Amperes) Vac (50/50 Hz)		Catalog Number
		120	277	
2	15	65,000	14,000	GHQRDEL2015 GHQRDEL2020
2	20	65,000	14,000	

① Not recommended for existing PRC25, PRC100, PRC750, PRC1000, PRC2000 systems. GHQRSPEL controllable circuit breakers are compatible with these systems.

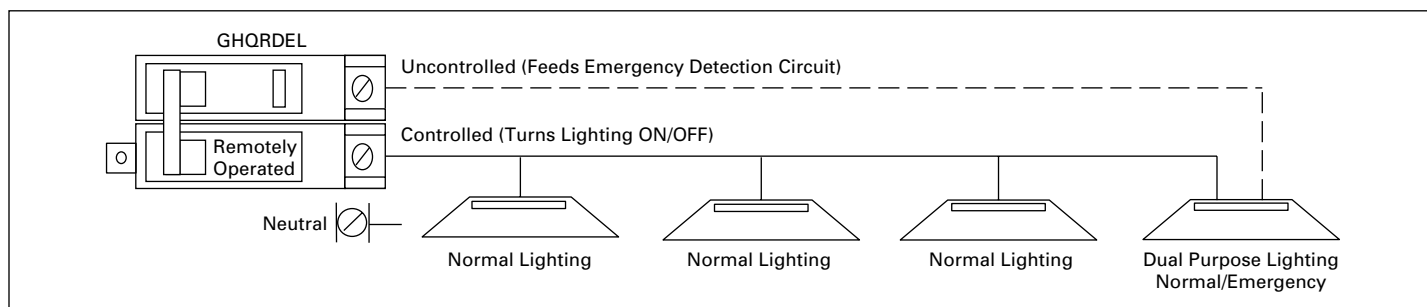

Figure 23.1-42. Emergency Lighting Control Using GHQRDEL Emergency Controllable Circuit Breaker

Remote Relay Unit (RRU-1)



Remote Relay Unit (RRU-1)

The Remote Relay Unit (RRU-1) is available in 120, 277 Vac input voltage configurations. The RRU-1 can be used to force all outputs in the Pow-R-Command panelboard to predetermined scene regardless of the controller programmed output status. This allows the override of outputs during loss of normal (grid) power to allow an alternate power source to drive the lighting loads. Once the RRU-1 senses the normal power returning, Pow-R-Command panelboard will return to the normal programmed operating mode.

The RRU-1 provides a dry contact closure to a Pow-R-Command controller digital input when normal (grid) power is lost. When this digital input is programmed as priority override, this contact closure forces all controllable circuit breakers in the panelboard to the ON state. This priority override condition takes priority and will remain in effect until the contact closure from the RRU-1 is opened. Controller can also be programmed to force all dimmed loads equipped with 0–10 Vdc dimming circuitry to full ON.

For emergency applications, Pow-R-Command Master Panelboard must be fed from an emergency power source.

Table 23.1-16. Remote Relay Unit (RRU-1)

Description	Catalog Number
UL 924 remote relay unit 120 Vac	RRU-1-120V
UL 924 remote relay unit 277 Vac	RRU-1-277V

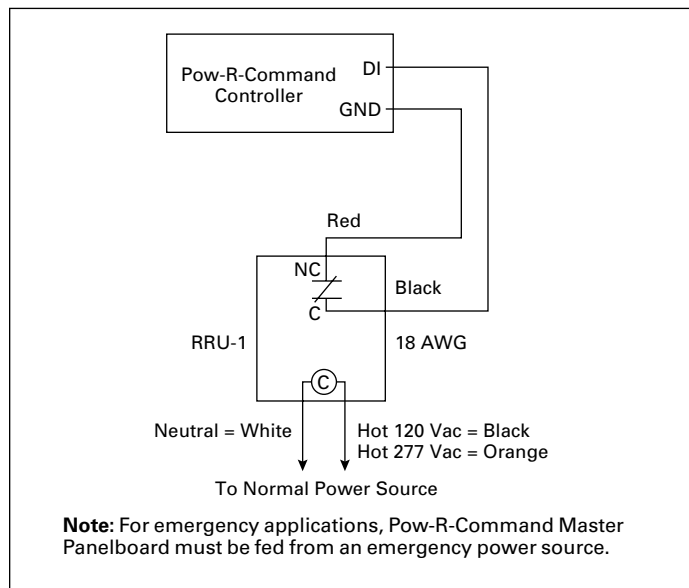

Figure 23.1-43. RRU-1 Wiring to Pow-R-Command Controller

Emergency Power Control (CEPC-1)



Emergency Power Control (CEPC-1)

The Emergency Power Control (CEPC) device allows the control of emergency lighting fed from a Pow-R-Command panelboard. The CEPC senses a local, single normal power circuit. The CEPC-1 is available in 120 Vac and 277 Vac input voltage configurations. As long as normal power is present, the CEPC permits normal and emergency switching of the lighting load from Pow-R-Command intelligent panelboards. If normal power is lost for any reason, the CEPC will force the connected emergency fixtures ON. This device includes a test switch for verifying proper functionality.

Features

- Eliminates energy waste by allowing emergency lighting to be switched
- Fail safe operation
- Visible emergency power LED
- Visible regular power LED
- Integral test switch
- Automatic diagnostic test feature
- Senses local circuit power loss
- Available in 120 Vac or 277 Vac
- UL 924 listed, meets NEC, OSHA and NFPA safety codes

Table 23.1-17. Emergency Power Control (CEPC-1)

Description	Ratings	Catalog Number
Emergency control power non-dimmed loads	120/277 Vac	CEPC-1
Emergency control power 0–10 Vdc loads	120/277 Vac	CEPC-1-D

Note: Consult factory for additional information.

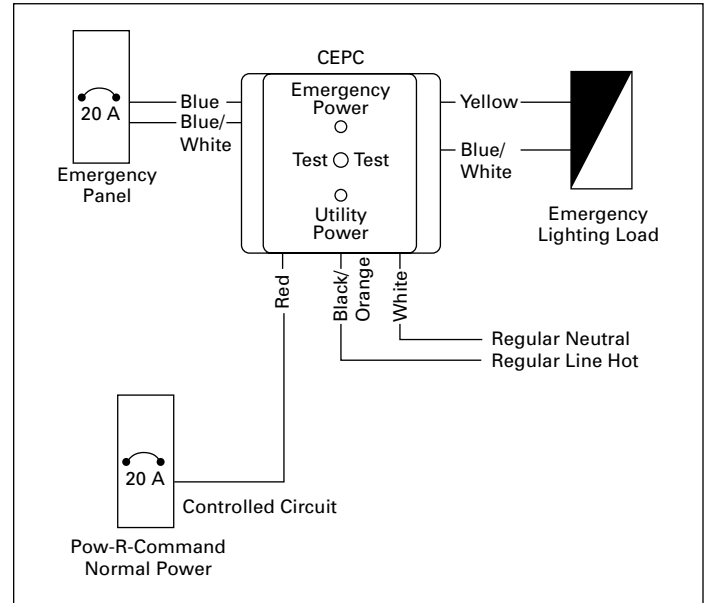

Figure 23.1-44. CEPC-1 Wiring Diagram for Non-Dimming Loads

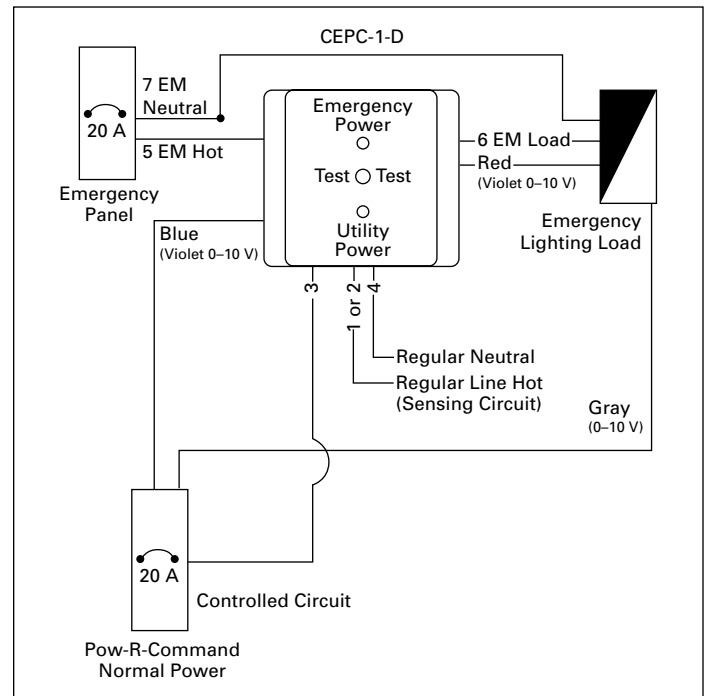

Figure 23.1-45. CEPC-1-D Wiring Diagram for 0–10 Vdc Dimming Loads

UL 924 Uninterruptible Power Supply



UL 924 Uninterruptible Power Supply

UL 924 Uninterruptible Power Supply (UPS) can be used to provide 90 minutes of backup power for egress lighting loads when normal power is lost. Eaton's emergency lighting UPSs are UL 924 tested and certified, providing the industry's highest capacity and smallest footprint solution.

Features

- Configured with external line and match battery cabinets to provide 90 minutes of backup time to meet UL 924 standard
- Manually operated test switch for conducting mandated equipment tests
- Protected test switch and interface protected from accidental operation and non-authorized users
- Enhanced communication capabilities for network connectivity and remote management applications

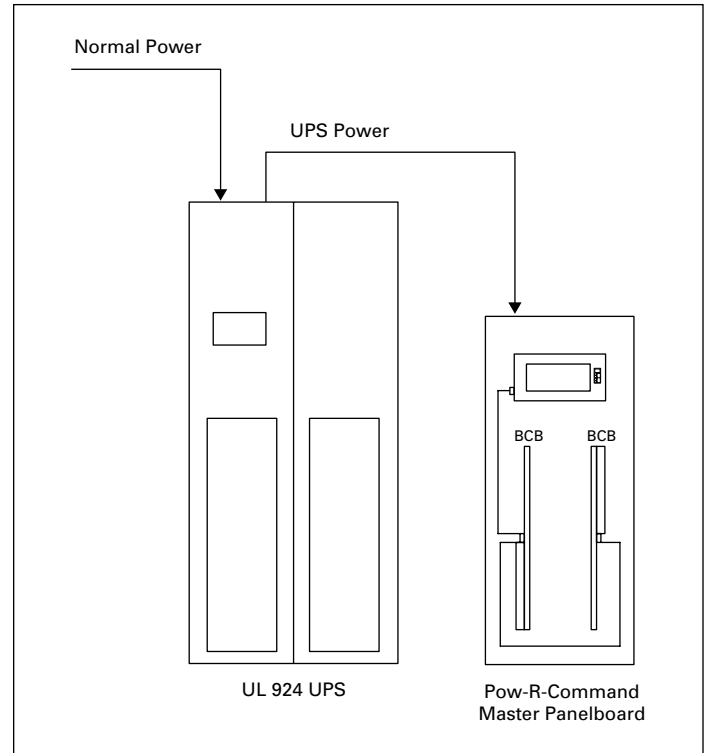

Figure 23.1-46. UL 924 UPS Connection to Pow-R-Command

Note: For UL 924 UPS information, visit Eaton.com/UL924UPS.

Receptacle Control

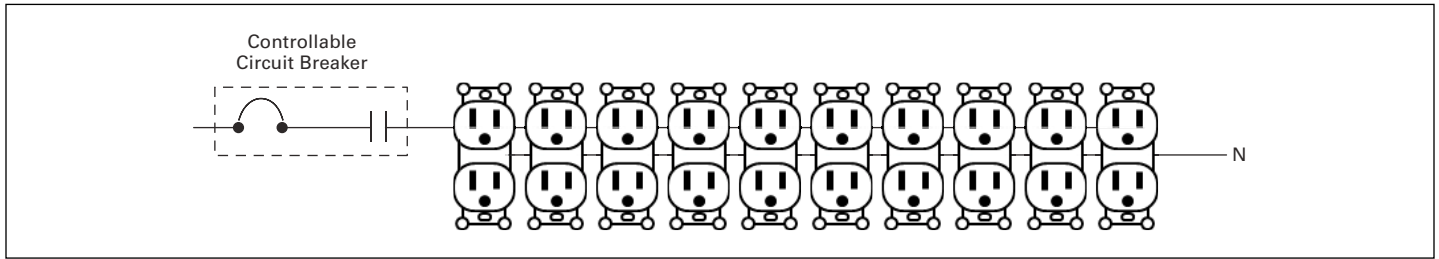

Figure 23.1-47. Plug Load Controllable Circuit Breaker (BABRSP)

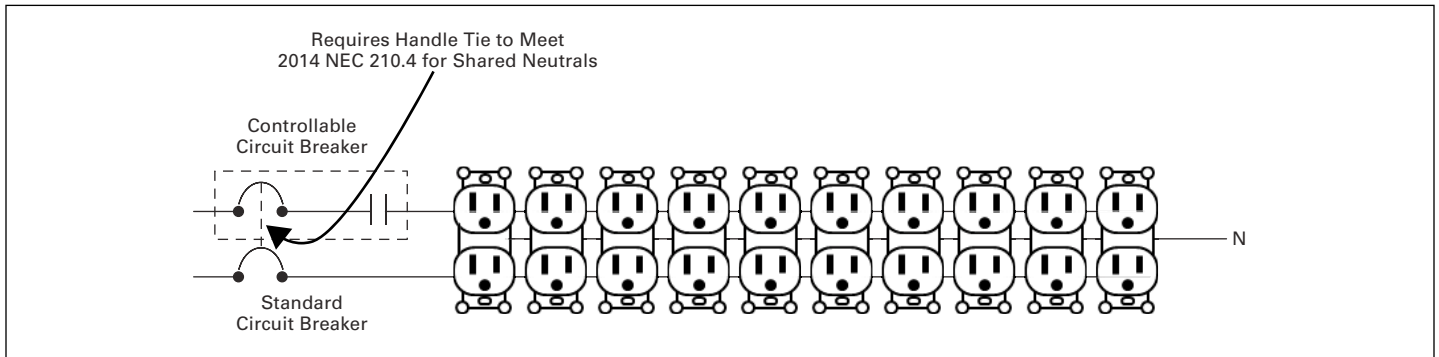

Figure 23.1-48. Split Receptacle Control Using Controllable Circuit Breaker (BABRSP) and Standard Circuit Breaker



Figure 23.1-49. Split Receptacle with Permanent Marking on Controlled Connection

Integrated Metering

General Description

Pow-R-Command intelligent panelboards can be configured to include PXM350 mains meter or PXBCM branch circuit monitor. PXM350 meter is used for metering mains only and includes meter, PTs and CTs with disconnect, and factory wiring. PXBCM branch circuit monitor can meter a maximum of 84 branch circuits in either single-section or two-section panelboard configurations.

PXM350 Mains Meter



PXM350 Panelboard Mains Meter

PXM350 is a compact, affordable energy meter that combines exceptional performance and easy installation to deliver a cost-effective solution for energy and power monitoring applications, as well as submetering applications.

Because of its compact size, the PXM350 is an ideal solution for panelboard applications to monitor the main power coming into the panelboard. Use the PXM350 for applications in lighting appliance and small power distribution panelboards up to 400 A.

With the rapidly changing emphasis on LEED designs, the PXM350 helps you to meet the Measurement and Verification points required by LEED and the U.S. Green Building Council.

All models include pulse output and phase loss alarms for maximum versatility. The Modbus output option offers added flexibility for configuration, communication and data analysis.

PXM350 allows you to:

- Verify energy bills
- Make informed load shifting and shedding decisions
- Fairly and accurately allocate energy costs to users
- Identify wasteful practices
- Decrease unnecessary usage
- Produce an energy profile
- Secure the optimum utility rate structure

Typical Applications

- Commercial submetering
- Energy management
- Industrial monitoring
- Cost allocation

Features

- Economical and compact wathour meter with demand
- Backlit LCD display for local reading
- Compatible with PRC2000E controller MLAN network, metering information is available over an ethernet connection when using controller ModbusTCP pass-through mode; refer to MLAN networks on **Page 23.1-14**
- Compatible with the Power Xpert Gateway for remote monitoring
- Monitors: voltage, current, power factor, frequency
- Power: real, reactive and apparent
- Energy: real, reactive and apparent
- Optional data logging capability
- Optional serial communications (Modbus RTU)
- Revenue grade, ANSI C12.20 0.5% accuracy, IEC 62053-22 Class 0.5S
- User-enabled password protection
- On-board diagnostics



Figure 23.1-50. Eaton Pow-R-Command Intelligent Panelboard

PXBCM Branch Circuit Monitor

PXBCM branch circuit monitor provides a means to monitor the main power coming into the panelboard and up to four additional three-phase meters. The PXBCM can be used in lighting appliance, small power distribution panelboards up to 400 A with branch breakers rated 100 A or below. The PXBCM can be used to meet the measurement and verification requirements. Requires 28-inch wide enclosure when integrated in a Pow-R-Command intelligent panelboard.

With Modbus RS-485 and TCP output standard, the PXBCM offers flexibility for onboard configuration, as well as communication and data analysis through an integrated web server or a number of building automation sources, including Eaton's Power Xpert and Foreseer® products.

Two basic panelboard configuration options:

- Main and branch devices
- Branch devices only

PXBCM allows you to:

- Make informed load shifting and load shedding decisions
- Fairly and accurately allocate energy costs to users
- Identify wasteful practices
- Decrease unnecessary usage
- Produce an energy profile

Typical Applications

- Energy management
- Industrial monitoring
- Cost allocation
- Data center management
- Light commercial
- Industrial
- Institutions

Features

- Power and energy readings at the branch circuit level
- Integrated web server for remote monitoring and configuration
- Optional remote color touchscreen display for local reading
- Compatible with PRC2000E controller MLAN network, metering information is available over an ethernet connection when using controller ModbusTCP pass-through mode; refer to MLAN networks on **Page 23.1-14**
- Compatible with the Power Xpert gateway for remote monitoring

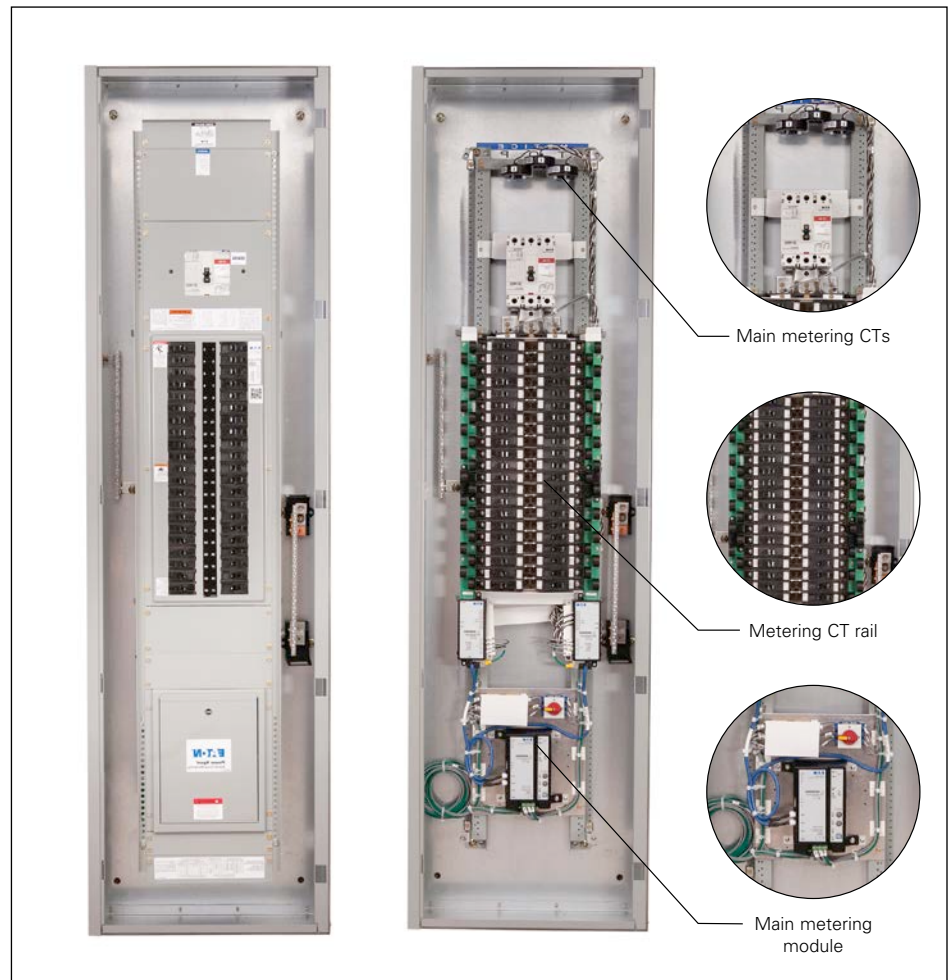

Figure 23.1-51. PXBCM Branch Circuit Monitor ①

① Requires 28-inch wide enclosure when integrated in a Pow-R-Command intelligent panelboard.

Building Management System Integration

General Description

Pow-R-Command lighting and plug load control systems are often connected to building management systems. There are two main methods of connecting to building management systems:

- Systems integration is where two systems are connected using communications. Systems that are integrated generally share more information and provide more control options, i.e., control and status
- Systems interfacing is where two systems are connected using dry-contacts. Systems that are interfaced may not provide status feedback between the systems

PRC2000E controllers provide a BACnet/IP communications protocol integration path to the building automation system. Controller status and control points are automatically mapped as BACnet objects. Both PRC-E controller and building management system need to be connected to the same subnet to establish communications between the two systems. Once connected, the building management system can auto discover the controller BACnet objects.

BACnet objects include:

- Controllable circuit breaker group
- Individual controllable circuit breaker
- Digital inputs
- Analog inputs
- Analog outputs

Refer to PRC-E Series Installation Manual MN014003EN, Appendix C, BACnet Integration for more technical information.

Integrated PXM350 mains meter or PXBCM branch circuit monitor metering information is available via single ethernet connection when using PRC2000E controller ModbusTCP pass-through mode. Refer to MLAN networks on **Page 23.1-14**.

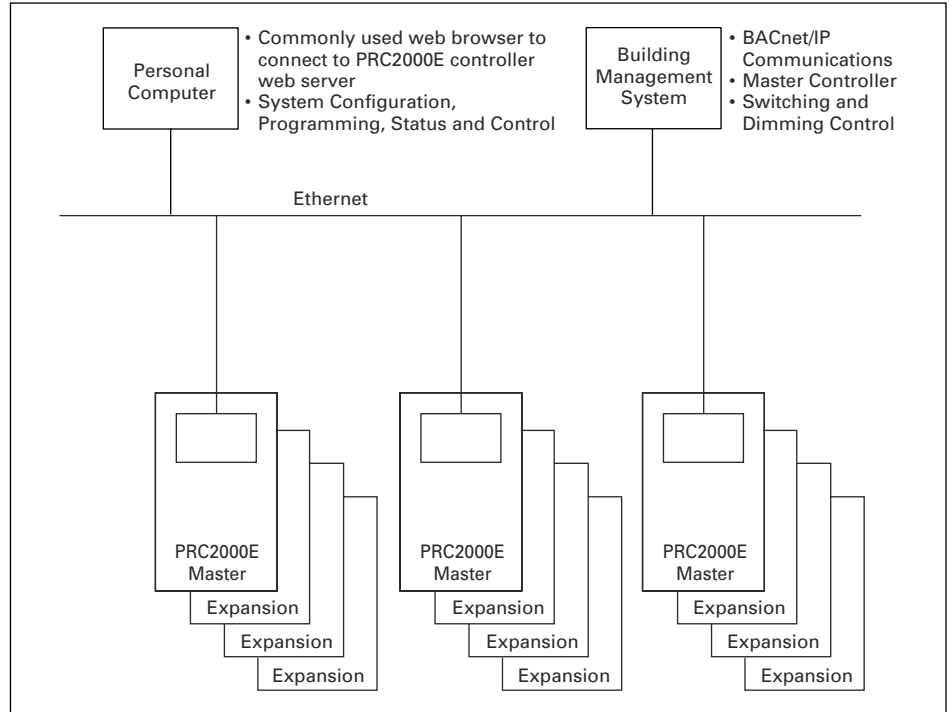

Figure 23.1-52. Typical Integration Network Architecture

Third-Party Modbus Master Control Connection

General Description

Pow-R-Command Expansion Panelboards can be directly connected to a Modbus Master Controller using an RS-485 RTU network. This network functions the same as the Pow-R-Command SLAN sub-network. Controllable circuit breaker status and control is achieved by sending standard Modbus commands from the Modbus Master Controller to the Breaker Control Bus (BCB).

A maximum of 16 Breaker Control Bus can be connected to the network. Each BCB is assigned a unique address between BCB1 and BCB16 using onboard DIP switches. It is recommended that the first Pow-R-Command panelboard connected to the Modbus Master be configured as a Powered Expansion Panelboard (PRCEPP). This configuration includes a control power supply designed to provide power to Breaker Control Bus addressed between BCB1 and BCB8 and switch controllable circuit breakers.

Another Powered Expansion Panelboard would be needed to power Breaker Control Bus between BCB9 and BCB16.

Refer to Third Party Modbus-SLAN drawing. Consult factory for Breaker Control Bus integration documentation.

Note: For Third-Party Modbus-SLAN standard drawing references, visit Eaton.com/lightingcontrol.

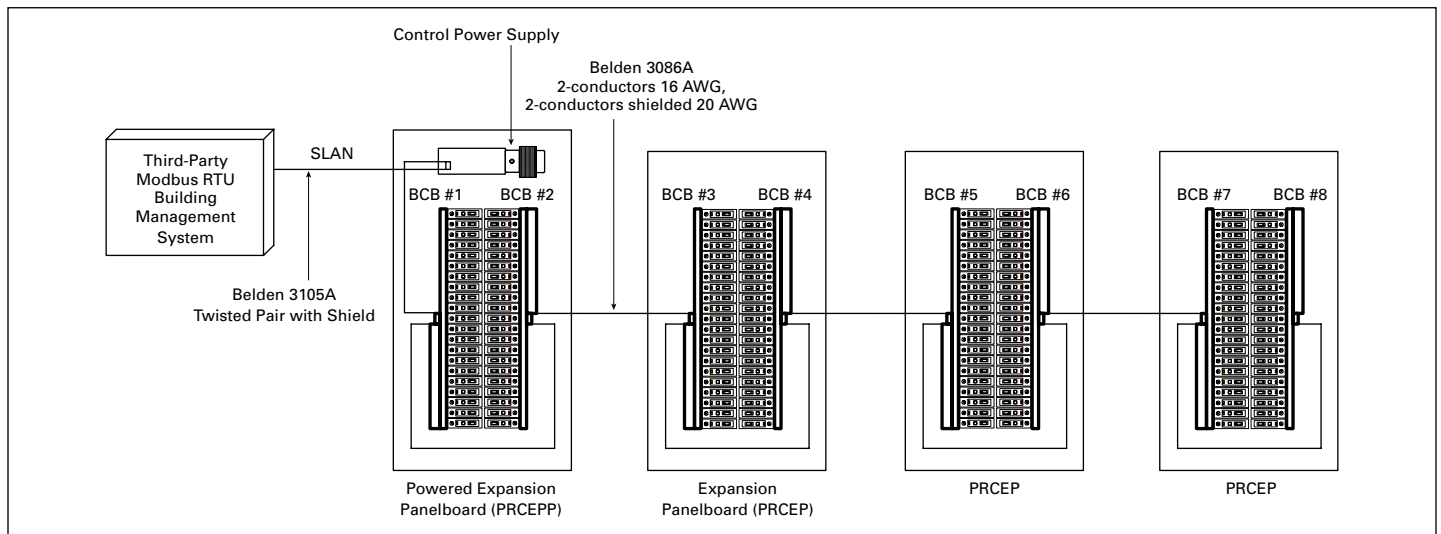

Figure 23.1-53. Third-Party Modbus Master Control Connection

Note: For PRCE-Third-Party Master typical drawing references, visit Eaton.com/lightingcontrol.

Panelboard Pow-R-Command Retrofits

Eaton PRL1a and PRL2a lighting panelboards can be retrofitted with Pow-R-Command electronics and controllable circuit breakers to provide lighting and plug load control.

Breaker Control Bus (BCB) switching electronics are mounted to the existing panelboard interior rails using the single screw mounting tab found on both ends of the device. Only standard circuit breakers connected to loads designated to be controlled need to be replaced with controllable circuit breakers. When the panelboard is configured with BCB on each side, a factory-assembled BCB-to-BCB SLAN cable is used to interconnect the BCBs. With BCBs and controllable circuit breakers installed, the panelboard is now configured as a PRC Expansion Panelboard (PRCEP). Refer to Expansion Panelboard on **Page 23.1-10** to learn more about PRCEP panelboard configurations.

Typically existing panelboards do not have the box height required to add the controller in the panelboard. External mounted controllers with control power supply are provided in NEMA 1 enclosure and mounted near the Expansion Panelboards. Refer to External Mounted Controllers on **Page 23.1-6** to learn more about these devices.

Retrofitted Expansion Panelboards and External Mounted Controllers are connected using the Master/Expansion SLAN sub-net network by installing Alpha 1064 cable with 16 AWG, four conductors between the devices. Refer to Master Panelboard to Expansion Panelboard SLAN Sub-net Network on **Page 23.1-12**.

- Pow-R-Command retrofits into existing Eaton PRL1a and 2a lighting panelboards
- Panelboards are converted to Pow-R-Command Expansion Panelboards (PRCEP) by installing Breaker Control Bus and controllable circuit breakers
- External Mounted Controller is mounted near the retrofitted PRCEP panelboard
- Factory-assembled BCB-to-BCB cables are used for panelboard interconnections between BCBs
- Controller and PRCEP are connected using SLAN sub-net network
- SLAN requires Alpha 1064 cable with 16 AWG, four conductors



Breaker Control Bus Retrofit Kit

Table 23.1-18. Breaker Control Bus Retrofit Kit Selection

Description	Catalog Number
Breaker control bus (BCB)—21 circuits—retrofit kit	PRCBCB21R
Breaker control bus (BCB)—15 circuits—retrofit kit	PRCBCB15R
Breaker control bus (BCB)—9 circuits—retrofit kit	PRCBCB9R



BCB-to-BCB SLAN Cables

Table 23.1-19. BCB-to-BCB Selection

Description	Catalog Number
BCB-to-BCB / 42-circuit panelboard	PRCSLAN42B
BCB-to-BCB / 30-circuit panelboard	PRCSLAN30B
BCB-to-BCB / 18-circuit panelboard	PRCSLAN18B

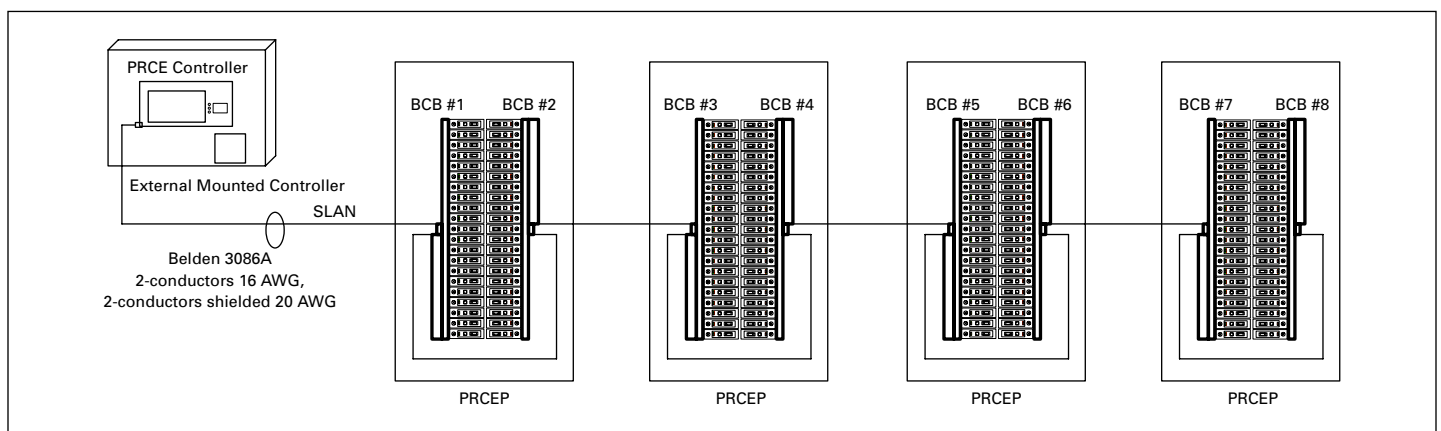

Figure 23.1-54. External Mounted Controller SLAN Connection to Retrofitted Expansion Panelboards

Note: For PRCE-SLAN-External Cabinet typical drawing references, visit Eaton.com/lightingcontrol.

Industry standard lighting panelboards not manufactured by Eaton can be retrofitted with Pow-R-Command lighting and plug load controls. Eaton supplies standard panelboard interior with Breaker Control Bus (BCB) switching electronics and controllable circuit breakers. Interior is configured with required mains device and standard circuit breakers if required to power non-switched loads. Using customer supplied panelboard box dimensions a custom cover is supplied. Contractor simply bolts interior and cover to the box. Consult factory for retrofit panelboard take-off sheet.

Typically existing panelboards do not have the box height required to add the controller in the panelboard. External mounted controllers with control power supply are provided in NEMA 1 enclosure and mounted near the Expansion Panelboards. Refer to External Mounted Controllers on **Page 23.1-6** to learn more about these devices.

Retrofitted Expansion Panelboards and External Mounted Controllers are connected using the Master/Expansion SLAN sub-net network by installing Alpha 1064 cable with 16 AWG, four conductors between the devices. Refer to Master Panelboard to Expansion Panelboard SLAN Sub-net Network on **Page 23.1-12**.

- Pow-R-Command panelboard interiors retrofit into non-Eaton panelboard boxes
- Panelboard interiors generally assemble as Expansion Panelboard (PRCEP)
- PRCEP includes Breaker Control Bus switching electronics, controllable and non-controlled branch circuit breakers and mains device
- External Mounted Controller is mounted near the retrofitted PRCEP panelboard
- Controller and PRCEP are connected using SLAN sub-net network
- SLAN requires Alpha 1064 cable with 16 AWG, four conductors
- Consult factory for retrofit panelboard take-off sheet

Page ____ of ____

Panelboard Take-off Worksheet

Job Name _____ Panelboard Designation _____

Panel Specifications

W _____ H _____ D _____

a _____ b _____ c _____ d _____

e _____ f _____ g _____ h _____

Existing Pnlb Manufacturer _____

Model/Series Number _____

Main Device (MCB/MLO) _____

Voltage (208Y/120V, 480Y/277V) _____

Ampacity Rating _____

Short Circuit Rating _____

Bus Material (AL/CU) _____

Cable Entry (Top/Bottom) _____

Panel Mount (Surface/Flush) _____

Taken-off by _____

Telephone Number _____

Date _____

Dimensions (inches)

H _____ W _____ D _____

a _____ b _____ c _____ d _____

e _____ f _____ g _____ h _____

Valid Control Groups: A thru P Note: Submit Panelboard Pictures (JPEG) with and without Cover

Panel Schedule		Load Designation		Smart C/B (Y/N)		Load Designation		Panel Schedule	
Group	Ckt #	Load Designation	Amps	# of Poles	Smart C/B (Y/N)	Load Designation	Amps	# of Poles	Group
	1								2
	3								4
	5								6
	7								8
	9								10
	11								12
	13								14
	15								16
	17								18
	19								20
	21								22
	23								24
	25								26
	27								28
	29								30
	31								32
	33								34
	35								36
	37								38
	39								40
	41								42

Technical Support: 888-252-6286 Option 3
lightingcontrol@eaton.com

EATON
Powering Business Worldwide

Take-off kit 7/15/2011

Comments / Specials: _____

Figure 23.1-55. Panelboard Retrofit Take-Off Sheet (Consult Factory for Document)