

Low-voltage power distribution and control systems > Motor control centers >

Motor control centers— low voltage

Contents

General Description	29.1-2
General Description	29.1-2
Freedom	29.1-3
Freedom Arc-Resistant	29.1-3
Freedom FlashGard	29.1-3
FlashGard Arc-Resistant	29.1-3
Structure and Bus Options	29.1-4
Standard Structures and Structure Options	29.1-8
Devices	29.1-10
Main Devices	29.1-10
Surge Protective Devices	29.1-13
Metering and Bus Protection	29.1-14
Power Factor Correction Capacitors	29.1-14
Feeder Tap Units	29.1-15
Automatic Transfer Switches	29.1-17
Panelboards	29.1-18
Units	29.1-18
Solid-State Reduced Voltage Starters (SSRV)	29.1-33
Adjustable Frequency Drives	29.1-35
Harmonic Correction Units	29.1-40
Application Data	29.1-41
Dimensions	29.1-41
Weights	29.1-49
Heat Loss	29.1-49



EATON

Powering Business Worldwide



More about this product
Eaton.com/mcc



Complete library of design guides
Eaton.com/designguides

General Description



Freedom Motor Control Center



Freedom Arc-Resistant Motor Control Center



Freedom FlashGard Motor Control Center



Freedom FlashGard Arc-Resistant Motor Control Center

Overview

Eaton's motor control centers (MCCs) provide a convenient method for grouping motor control, as well as associated distribution equipment. MCCs may be applied on electrical systems up to 600V, 50 or 60 Hz, having available fault currents of up to 100,000 A rms. Enclosure designs include NEMA® 1 Gasketed as well as NEMA 2, 12, 3R and 3R walk-in. All controllers are assembled with Eaton components of proven safety, quality and reliability. All components are wired in accordance with NEC® and UL® standards. An ongoing temperature and short-circuit design test program, as required by UL 845, ensures a quality product that meets the latest safety codes. Freedom DC motor control centers are available up to 250Vdc, having available fault currents up to 22,000 A rms. A comprehensive range of communications options are also available, including EtherNet/IP, Modbus® TCP, Modbus RTU, PROFIBUS and DeviceNet™.

MCCs provide the best method for grouping motor control as well as associated distribution equipment. Eaton's MCCs are specially designed to operate machinery, industrial processes and commercial building systems. The MCC enclosure consists of a strong and rigid self-supporting steel channel framework assembled into standardized vertical sections and bolted together to form a complete shipping section of up to 80.00 inches (2032.0 mm) maximum, four structures each. Structures include horizontal and vertical bus, insulation and isolation barriers, horizontal and vertical isolated wiring troughs, cable entrance areas, and space for inserting starter and control equipment.

All control units, removable or fixed mounted, are assembled with Eaton components of proven safety, quality and reliability. Specifically designed bus stabs, insertion guides, handle mechanisms and safety interlocks are added to form a standardized plug-in unit that meets the highest safety standards.

Market Segments

Eaton's MCCs have been designed to meet the specific needs of several industries including:

- Automotive
- Chemical
- Commercial construction
- Food and beverage
- Industrial construction
- Mining, metals and minerals
- Oil and gas (upstream, midstream and downstream)
- Pulp and paper
- Utility
- Water treatment and wastewater

Standards and Certifications

- UL 845 Listed
- NEMA ICS 18
- NEC section 430 Part H
- Seismic compliance to IBC 2009 and CBC 2010
- ABS certified for non-propulsion loads
- CSA 22.2 No. 0.22-11 Arc-Resistant
- Tested to C37.20.7 guidelines

Ratings

- 600 Vac / 250 Vdc
- Maximum 3200 A horizontal bus
- Maximum 1200 A vertical bus
- 42 kA, 65 kA and 100 kA short circuit withstand
- Operating temperature 0 °C (32 °F) to 40 °C (104 °F)
- Storage temperature -40 °C (-40 °F) to 65 °C (149 °F)

Key MCC Features

- Molded case and air circuit breaker mains
- Bimetallic and solid-state overloads
- Adjustable frequency drives (6-pulse) up to 400 hp VT
- IEEE 519 clean power drives (18-pulse) up to 500 hp VT
- Reduced voltage soft starts (RVSS) up to 1000 A
- Panelboards/transformers/ATS
- Metering/SPDs/feeder breakers
- MCPs/fused switch disconnects
- 16- and 21-inch deep enclosures
- 21-inch deep front-and-rear (common bus) design
- 1A to 2C wiring capability
- 120V / 240V or 480V coil options as well as 24Vdc
- Drawout NEMA Size 1 to 5
- Fixed NEMA 6 and higher

Table 29.1-1. Feature Comparison Key

Family	480V and Lower	600V	Compact Units	Arc Rating	Smart
Freedom	Yes	Yes	Yes	N/A	Yes
Freedom FlashGard	Yes	Yes	N/A	Preventive	Yes
Freedom Arc-Resistant	Yes	Yes	Yes	Type 2	Yes
FlashGard Arc-Resistant	Yes	Yes	N/A	Preventive and Type 2	Yes

Freedom

Eaton’s Freedom motor control center has been in production since 1994 employing the Freedom NEMA contactor in combination with multiple motor overload styles and either a fused switch or a molded case breaker disconnect. The Freedom motor control center meets all the above listed standards, ratings and features.

Freedom Arc-Resistant

Eaton’s Freedom Arc-Resistant is the first motor control center to be tested to a North American guideline specifically written for low-voltage motor control centers, unlike C37.20.7 that is a guideline for testing metal-enclosed switchgear up to 38 kV. Eaton’s Freedom Arc-Resistant motor control center is tested in accordance with CSA C22.2 No. 0.22-11 titled “Evaluation methods for arc resistant ratings of enclosed electrical equipment”. To meet the CSA guideline (and also the future C37.20.7 guideline) the following must be met.

- **Criterion 1: Deformation—**
Doors, covers and other items must not open. Distortion and bowing of these items is permitted but must not extend to the indicators placed around the enclosure for testing.
- **Criterion 2: Fragmentation—**
Fragmentation of the enclosure must not occur. Small items/parts are permitted to eject as long as their mass is 60 grams or less.
- **Criterion 3: Burn-through—**
Burn-through that causes holes in the enclosure must not occur in the freely accessible enclosure. Based on the results of this test, an Accessibility Type is achieved (Accessibility Type 1 or Type 2).
- **Criterion 4: Indicators—**
Indicators placed around the enclosure for testing must not ignite as a result of escaping gases or particles.
- **Criterion 5: Grounding—**
All grounding connections must remain effective.

Eaton’s Freedom Arc-Resistant motor control center is a Type 2, 50 ms device limited Arc offering. Device limited means that specific combinations of devices (units and assemblies) are tested so that an arc rating can be achieved. The combination of devices includes all the standard Freedom devices less a handful, which are covered under the Features section.

The Freedom Arc-Resistant motor control center is constructed out of 12-gauge sheet steel instead of the standard 14-gauge including the doors, side and back sheets and the top panels.

The width of the MCC is 8.00 inches (203.2 mm) wider than a standard Freedom MCC with 4.00 inches (101.6 mm) added to the left and to the right of the lineup to allow for gas to expand if an arc occurs. The depth of the Freedom Arc-Resistant motor control center is 21.00 inches (533.4 mm) deep and is front mount only. The Freedom Arc-Resistant motor control center is 90.00 inches (2286.0 mm) in height and does not come in reduced height. The Freedom Arc-Resistant does not need any venting or plenums to vent the gas, allowing the MCC to be mounted up against a wall or a ceiling to be brought down to the top of the MCC.

Freedom FlashGard

Eaton’s Freedom FlashGard motor control centers are an industry first in addressing the dangers associated with an arc flash event by minimizing the risk of arc flash exposure. Freedom FlashGard offers features to help prevent injury from electric shock, arc-flash burn and arc-blast impacts and is the first Arc Preventative MCC.

The Freedom FlashGard motor control center uses a “retractable stab” mechanism called RotoTract™ that allows the electrical worker to connect and disconnect line power to the unit from behind a dead front (closed door). Visual indication of the stab position is provided on the unit door on the “Connected” and “Disconnected” positions of RotoTract. Visual indication on the position of the shutters that enclose the stabs is also provided (open shutters indicates that stabs are extended and closed shutters indicate that the stabs are withdrawn). In addition, a number of safety interlocks prevents scenarios where removal or insertion of FlashGard bucket could compromise arc flash safety.

A motorized tool, such as an electric screwdriver with a 3/8-inch (9.5 mm) square bit or standard 3/8-inch (9.5 mm) drive ratchet is required to operate RotoTract’s “retractable stab” mechanism. An optional 120 V remote racking accessory with a pendant station is available as to enable the operator to operate the RotoTract from safely behind the arc flash boundary as prescribed by the National Fire Protection Agency (NFPA).

FlashGard Arc-Resistant

Eaton’s FlashGard Arc-Resistant motor control centers combine the arc containment features of Freedom Arc-Resistant motor control centers and the arc mitigating features of Freedom FlashGard motor control centers to provide the safest available option in the industry.

Structure and Bus Options

NEMA Classifications (ICS 18)

Class I Control Centers

A mechanical grouping of combination motor control, feeder tap and/or other units arranged in a convenient assembly. Connections from the common horizontal power bus to the units are included. Interwiring or interlocking between units or to remotely mounted devices is not included. Only diagrams of the individual units are supplied.

When master terminal blocks are specified, a sketch showing general location of terminals is provided.

Class II Control Centers

The same as Class I, but designed to form a complete control system. They include the necessary electrical interlocking and interwiring between units and interlocking provisions to remotely mounted devices. A suitable diagram illustrating operation of the control associated with the motor control center will be provided.

When master terminal blocks are specified, the terminal arrangement and required wiring connections are shown on the diagram.

NEMA Types of Wiring

Type A includes no unit terminal blocks and no unit-to-unit wiring. Combination line starters power wiring are factory wired and assembled in the structure in the most efficient arrangement. Auxiliary devices can be supplied, wired or unwired as specified. All feeder circuit breaker or fusible disconnect units are in this classification.

Type B duplicates Type A except that all control wires terminate at terminal blocks on the side or near the bottom of each unit. Removable terminal blocks are standard for all control wiring.

Type C-S all factory-supplied control terminals are brought to a master terminal block located in the structure.

Type C-M all factory-supplied control terminals are brought to a master terminal block located in a separate marshaling structure.

Structures

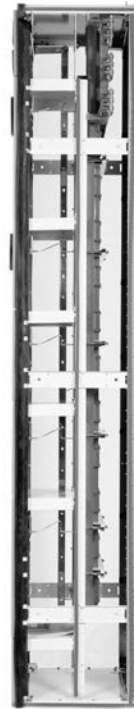

Standard Structure—Side View

Construction

The standard vertical structure is 90.00 inches (2286.0 mm) high and 20.00 inches (508.0 mm) wide. Front-mounted-only structures can be either 16.00 inches (406.4 mm) or 21.00 inches (533.4 mm) deep. Front-to-back unit mounting is 21.00 inches (533.4 mm) deep. Bolted back-to-back can be in 16.00-inch (406.4 mm) or 21.00-inch (533.4 mm) deep structures.

The free-standing structure framework is made of 12-gauge formed steel channels. The subframes for the front and rear of each structure are welded. These subframes are then bolted to longitudinal members to form the complete frame, which is rigid and self-supporting. Side, back and roof covers of 14-gauge steel (except where noted) are mounted with screw fasteners for quick and easy removal. All doors are 14-gauge steel (except where noted) with a 0.50-inch (12.7 mm) flange to provide a rigid, secure closure for all openings. Doors mounted on removable pin hinges are provided on all unit compartments. Vertical wireways, top horizontal wireways and bottom horizontal wireways are standard.

The unit pan forms the top barrier of each unit space. In conjunction with the unit wrapper, this provides isolation between adjacent units and wireways. The guide rails are an integral part of this pan and provide precise alignment of the unit stabs on the vertical bus.

Standard Structure Arrangements

Standard structural height is 90.00 inches (2286.0 mm) with 9.00-inch (228.6 mm) horizontal wireways available at top and bottom for wiring. The balance of vertical compartments, 72.00 inches (1828.8 mm), is available for mounting of control units. This space can provide up to 12 6.00-inch (152.4 mm) high (X spaces) or any combination thereof.

Note: In the rear of common vertical bus front-to-back structures, the top horizontal wireway is 15.00 inches (381.0 mm) high and the bottom wireway is 9.00 inches (228.6 mm). This means that front-to-back structures have only 66.00 inches (1676.4 mm) 11X of usable space in the rear. 72.00-inch (1828.8 mm) 12X of mounting space is available with a 3.00-inch (76.2 mm) bottom wireway. Two front-mounted only structures can be supplied in a front-to-back configuration, allowing 12X rear usable space (depth dimension will increase).

Special Structures

In addition to the standard 20.00-inch (508.0 mm) wide structure, extra wide structures are available in 4.00-inch (101.6 mm) increments up to 40.00 inches (1016.0) wide.

Reduced height structures, in increments of 6.00 inches (152.4 mm) 1X from 90.00 to 54.00 inches (2286.0 to 1371.6 mm), are available for applications with limited access.

Another special structure is a transition section between Type W and the Freedom Series. This structure is 10.00 inches (254.0 mm) wide to provide for horizontal bus splicing.

Paint

All enclosure parts are thoroughly cleaned and given a phosphatizing treatment to inhibit rust and to prime the metal for the finish coating. A 2 mil thick electrostatic powder paint coat is applied to all surfaces. The paint type and process meets UL 1332 for electrical equipment steel enclosures. All exterior enclosure covers and doors are painted ANSI 61 gray (Munsell No. 8.3G/6.10/0.54). For improved interior visibility, the interior of the enclosure and plug-in units are painted white (Munsell No. N9.43/0.21B, 0.23).

Enclosures

The standard enclosure type is NEMA Type 1 Gasketed General Purpose—Indoor. This enclosure is appropriate for installations with normal atmospheric conditions.

The NEMA Type 2 Dripproof—Indoor employs a special roof panel with a drip shield and water channels. This prevents liquid from dripping onto the front of the control center.

The NEMA Type 3R Rainproof and Sleet Resistant—Outdoor consists of a NEMA 1 gasketed enclosure mounted on a special base with an outdoor house erected around and over it. Non-walk-in, walk-in aisle and tunnel types are available.

The NEMA Type 12 Dust-tight and Driptight—Indoor has gasketed material around all doors, door cutouts, cover plates, side, top and back sheets. A gasketed bottom plate is provided with this enclosure. This construction provides maximum protection against airborne matter and dripping liquids.

Indoor enclosures comply with NEC UL 845's "Two Meter Rule" when the bottom of the MCC is at the same level as the operator's platform. MCCs elevated on a raised pad or installed on unembedded channel sills may require operator handle extensions for the uppermost operators. Handle extensions are optionally available and may be installed on-site.

Vertical Wireway

A vertical wireway is provided in each structure. Located on the right side, it extends the full 90.00-inch (2286.0 mm) height of the structure. The width of the wireway is 4-5/8 inches (117.5 mm) at the rear of the vertical frame members. Overall depth of the wireway is 8.00 inches (203.2 mm) providing a cross-sectional area of nearly 35 square inches (889 square mm) to easily accommodate control and load wiring. Supports are provided at suitable intervals to secure all wiring and cables.

The doors swing open 115° and opposite to the unit doors for maximum accessibility. The doors are mounted on concealed removable pin hinges for quick detachment and are secured in the closed position by spring-loaded quarter-turn indicating type fastener.



4-Inch Vertical Wireway



8-Inch Vertical Wireway

Horizontal Wireways

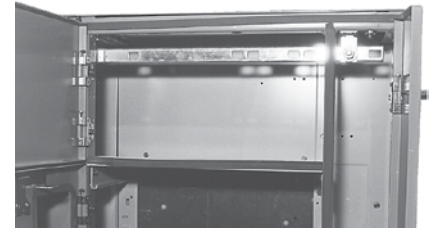

Top Horizontal Wireway



Bottom Horizontal Wireway

The top front horizontal wireway is 9.00 inches (228.6 mm) high and 8.00 inches (203.2 mm) deep in front-mounted only structures and in the front of back-to-back mounted structures. It extends the full width of each structure and is totally isolated from the main horizontal bus. The bottom horizontal wireway is 9.00 inches (228.6 mm) high and extends the full depth of the structure. The entire floor area under the control center is open for unrestricted conduit entry. For top entry, the top wireway can be increased to 15.00 inches (381.0 mm) high, reducing the bottom wireway height to 3.00 inches (76.2 mm).

For back-to-back unit mounted, the rear top horizontal wireway is 15.00 inches (381.0 mm) high and 5.00 inches (127.0 mm) deep.

All horizontal wireway openings are covered by doors for increased accessibility. Each door is mounted with removable pin hinges to allow quick detachment.

General Description

Bus System

The bus system is designed to efficiently distribute power throughout the MCC and provides inherent mechanical strength in the event of faults.

Vertical Bus



Vertical Bus Configuration

The vertical bus provides three-phase power distribution from the main horizontal bus into the vertical compartments. The bus is a unique angular configuration with a “Z” shape for front-mounted structures and for back-to-back. These shapes have the inherent mechanical strength to withstand fault stresses. They also provide a smooth stabbing surface for unit connection.

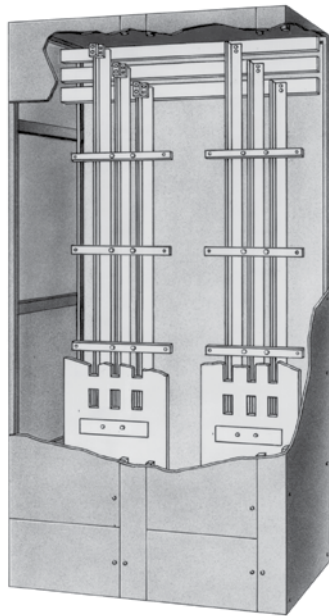

MCC Bus Layout

Due to the high-strength capability of the bus bars, bus bracing at 65,000 rms symmetrical amperes is standard. Optional bracing is available at 42,000 and 100,000 A rms. Bus braces are molded from a glass-reinforced polyester material, which is non-tracking and impervious to moisture and other adverse atmospheric operating conditions.

The vertical bus is available in ratings of 600, 800 and 1200 A for front-mounted only, and 600, 800 and 1200 A for back-to-back mounted. **Vertical bus bars are tin-plated copper only.** In addition to tin plating having environmental superiority over silver, its mechanical strength is better able to withstand the stresses of unit insertion and removal on and off the bus. Vertical bus of the incoming section will match the horizontal bus when applicable.

Isolation of the Freedom vertical bus compartment from the unit compartment is accomplished by a full height isolation barrier, which is a single sheet of glass-reinforced polyester with cutouts to allow the unit stabs to engage the vertical bus. Snap-in covers are available for the cutout openings to provide total isolation during maintenance procedures.

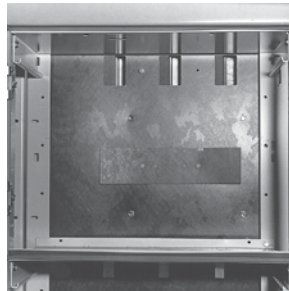

Standard Isolation Barrier

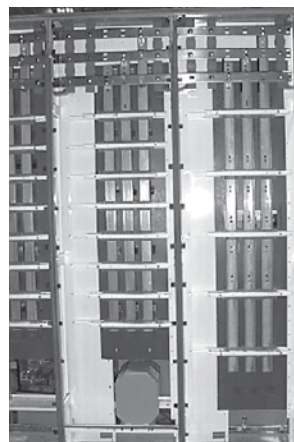

Standard Isolation Barrier Rear View

When insulation and isolation of the vertical bus is required, a **labyrinth design barrier**, as shown below, as an option for Freedom and as a standard for Freedom Arc-Resistant and Freedom FlashGard. This barrier is molded glass-reinforced polyester and forms a labyrinth around the bus bars to prevent fault propagation. This design provides maximum protection against phase-to-phase insulation breakdown. Thermal efficiency is maintained by a close tolerance fit between the bus bars and the barrier, which minimizes air pockets.

An automatic shutter mechanism is standard with the labyrinth barrier to provide complete isolation of the vertical bus. The shutter moves automatically to cover the stab openings when a unit is removed. This provides maintenance personnel with maximum protection because the vertical bus is never exposed. As the unit is reinserted in the compartment, the shutter moves sideways to uncover the stab openings in the barrier.

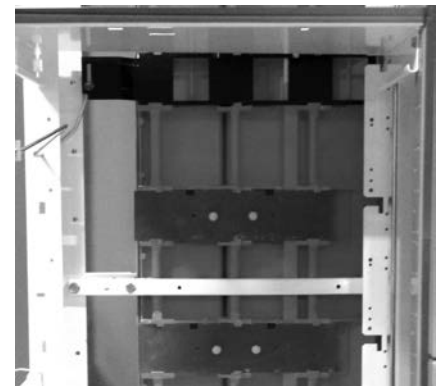

Labyrinth Barrier with Automatic Shutter Mechanism



Labyrinth Showing Phase Isolation

Horizontal Bus

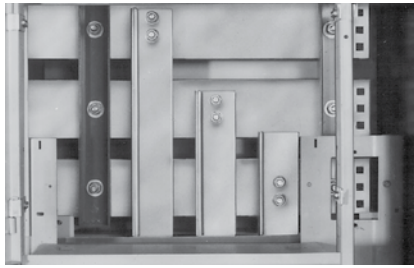

Horizontal Bus

The main horizontal bus provides three-phase power distribution from the incoming line or primary disconnect device to each vertical structure in the motor control center. The bus bars are mounted in a vertical plane, edge to edge. This mounting produces an exceptionally strong assembly, able to withstand high fault current stresses.

The main horizontal bus is rated at 600 A as standard with ratings of 800, 1200, 1600, 2000, 2500 and 3200 A optionally available. Tin-plated copper horizontal bus bars are supplied as standard. Silver-plated copper horizontal bus bars are an option.

Note: 3200 A horizontal bus available in NEMA 1A enclosure only and 65 °C rise above 40 °C ambient only.

The horizontal main bus is isolated from the top horizontal wireway compartment by a metal isolation barrier. This two-piece steel barrier extends to the full width of each vertical structure. The two-piece design allows access to bus connections without the removal of the entire barrier, for added maintenance convenience. The bus bar layout permits front access to all bus connections. This allows maintenance personnel to make splices and check splice bolt torques from the front of the structure.

Neutral Assemblies

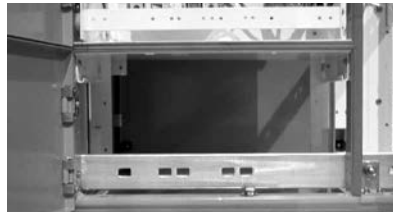

Neutral Bus (Bottom)

For three-phase, four-wire applications, a neutral landing pad is provided as standard. This is a 100% rated neutral. As an option, half or fully rated neutral bus can be supplied in the bottom of the entire MCC.

Ground Bus

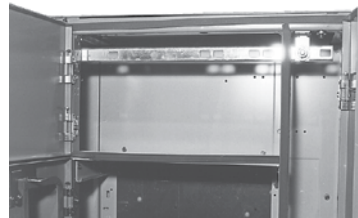

Ground Bus (Top)

Copper ground bus, rated 300 A 0.25-inch by 1.00-inch (6.4 mm by 25.4 mm) is supplied as standard. Mounting is across the top of each vertical structure in the horizontal wireway. The bus can also be mounted across the bottom when the bottom 9.00 inches (228.6 mm) are not occupied by units or master terminal blocks. A 0.25-inch by 2.00-inch (6.4 mm by 50.8 mm) optional copper ground bus rated 600 or 800 A is also available.

An optional 300 A vertical tin-plated only copper ground bus is available. Located in the vertical wireway, it provides direct starter unit grounding.

Standard Structures and Structure Options

The standard Freedom, Freedom Arc and Freedom FlashGard structure is NEMA 1, gasketed, 90.00 inches (2286.0 mm) high, 20.00 inches (508.0 mm) wide with a depth as shown in **Figure 29.1-1**. Each standard structure has a 9.00-inch (228.6 mm) high horizontal wireway at the top and at the bottom and a 4.00-inch (101.6 mm) wide full height vertical

wireway at the right. All wireway doors are hinged and secured with 1/4-turn latches. The standard busing is 600 A, UL rated, copper horizontal bus and 300 A, UL rated, copper vertical bus braced for 65,000 symmetrical amperes. Many other bus sizes and types are available. Also included as standard is a vertical bus isolation barrier.

Table 29.1-2. Standard Structures and Structure Options—Dimensions in Inches (mm)

Description	
Standard Structures	
16.00 (406.4) deep structure ①	Structure 1
21.00 (533.4) deep structure	Structure 2
Front mounting only	Structure 3
Front and rear mounting ①	
4.00 (101.6) of additional structure width, 32.00 (812.8) maximum ①	
8.00 (203.2) vertical wireway in lieu of standard 4.00-inch (101.6)	
Special Structures	
Single corner section for "L" configuration of MCC	
Transition section ①	
Series 2100 to Type W	
10.00 (254.0) wide—front aligned	
Plug-in blank relay mounting space, per 6-inch	Any 6.00 (152.4) height
Fixed-mounted relay back pan, full depth of structure	
20.00 (508.0) structure with wireway	13.00 (330.2) with usable panel
24.00 (609.6) structure with wireway	17.00 (431.8) with usable panel
28.00 (711.2) structure with wireway	21.00 (533.4) with usable panel
20.00 (508.0) structure without wireway	17.00 (431.8) with usable panel
24.00 (609.6) structure without wireway	21.00 (533.4) with usable panel
28.00 (711.2) structure without wireway	25.00 (635.0) with usable panel
32.00 (812.8) with double door ①	
36.00 (914.4) with double door ①	
40.00 (1016.0) with double door ①	
Relay Structures	
(per complete structure with full fixed mounting back pan)	
20.00 (508.0) structure with wireway	Complete section
24.00 (609.6) structure with wireway	Complete section
28.00 (711.2) structure with wireway	Complete section
20.00 (508.0) structure without wireway	Complete section
24.00 (609.6) structure without wireway	Complete section
28.00 (711.2) structure without wireway	Complete section
Plexiglass see-through door insert for PLC structure	6.00 (152.4) increments
19.00 (482.6) instrumentation mounting racks installed in relay structure	Consult Eaton

① Not available in Freedom Arc-Resistant.

Table 29.1-3. Structure Modifications—Dimensions in Inches (mm)

Channel floor sills: 11-gauge, 1.00 x 3.00 (25.4 x 76.2)
NEMA 12 dust-proof, includes bottom plate ②
Bottom plate for NEMA 1 gasketed enclosure
Enclosure space heaters
Thermostat for space heater control
Pullbox kit for cable and wiring to be field mounted on top structure ②
12.00 (304.8) high
18.00 (457.2) high
24.00 (609.6) high
Rear hinged structure door, 72.00 (1828.8) high ②
NEMA 2 drip shield on top of MCC ②
NEMA 3R non-walk-in—front-mounted, back-to-back ②
NEMA 3R walk-in aisle-front mounted ②
NEMA 3R walk-in tunnel type ②
NEMA 4X—consult factory ②
Special reduced height structures ②
Seismic certification (earthquake qualification)
UL handle extension ③

② Not available in Freedom Arc-Resistant.

③ Structures are designed to comply with the UL 2-meter requirement. Disconnect operating handle is not more than 2 meters [78.00 inches (1981.2 mm)] above the bottom of the MCC. Motor control centers elevated on a raised pad no taller than 4 inches or installed on embedded channel sills require operator handle extensions for the uppermost operators. UL handle extension optionally available when required.

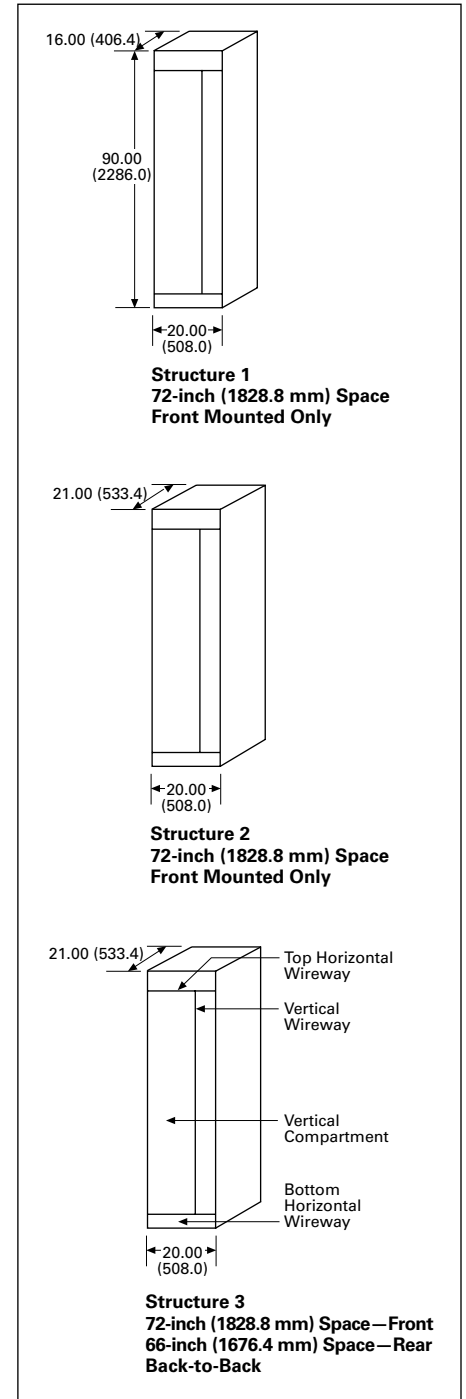

Figure 29.1-1. Structure—Dimensions in Inches (mm)

Table 29.1-4. Bus Modifications—Dimensions in Inches (mm)

Eaton’s Freedom Series MCCs bear the UL label. Service entrance labeling is available.

Description			
Main Bus, Per Vertical Structure			Cu—Tin-Plated (Standard)
Copper Horizontal Bus Ratings Tin-Plated	50 °C	65 °C (Standard)	
600 A Size	0.25 x 2.00 (6.4 x 50.8)—Bars/Phase 1	0.25 x 2.00 (6.4 x 50.8)—Bars/Phase 1	—
800 A Size	0.25 x 3.00 (6.4 x 76.2)—Bars/Phase 1	0.25 x 2.00 (6.4 x 50.8)—Bars/Phase 1	—
1200 A Size	0.25 x 2.50 (6.4 x 63.5)—Bars/Phase 2	0.25 x 3.00 (6.4 x 76.2)—Bars/Phase 1	—
1600 A Size	0.25 x 3.00 (6.4 x 76.2)—Bars/Phase 4	0.25 x 3.00 (6.4 x 76.2)—Bars/Phase 2	21.00 (533.4) deep ②
2000 A Size	0.25 x 2.50 (6.4 x 63.5)—Bars/Phase 6	0.25 x 2.50 (6.4 x 63.5)—Bars/Phase 4	21.00 (533.4) deep ②
2500 A Size	0.25 x 3.00 (6.4 x 76.2)—Bars/Phase 8 ①	0.25 x 3.00 (6.4 x 76.2)—Bars/Phase 6	21.00 (533.4) deep ③
3200 A Size ①	N/A	0.25 x 3.00 (6.4 x 76.2)—Bars/Phase 8	21.00 (533.4) deep ③④
Silver-plated bus main horizontal bus			Optional
Insulated main horizontal bus, per vertical structure (taping)			Optional
Vertical bus, per vertical structure: 300 A—copper (tin-plated)			Standard ⑤
Increased bus capacity: rated at 600 A (front-mounted only)			Cu only
Rated at 600 A (back-to-back)—copper			Standard
Rated at 800 A (back-to-back and front)			Cu only
Rated at 1200 A			Cu only
Increased mechanical bus bracing, per vertical structure:			
42,000 A rms symmetrical short-circuit current			Optional
65,000 A rms symmetrical short-circuit current			Standard
100,000 A rms symmetrical short-circuit current ①			Optional
Vertical bus isolation barrier, per vertical structure			Standard
Labyrinth design insulation-isolation vertical bus barrier			Optional Freedom
Ground bus, 300 A standard, per vertical structure			Standard Cu
Increased capacity ground bus only, 600 A, 1/4- x 2.00-inch (6.4 x 50.8 mm), per vertical structure			Standard Cu
Neutral bus, ungrounded for three-phase, four-wire power, per vertical structure ⑥			Cu
Splice plates			—

- ① Not available in Freedom Arc-Resistant.
- ② Requires 21.00-inch (533.4 mm) deep structure.
- ③ Requires 21.00-inch (533.4 mm) deep structure. Not available in front-and-rear structure.
- ④ Contact Eaton for 3200 A dimensions.
- ⑤ Vertical bus and unit stabs are tin-plated copper only.
- ⑥ Neutral is half-rating of horizontal bus.

Bus Duct Entry: Pow-R-Way III (Sandwich Type) to Horizontal Bus or Main Disconnect—Pull Box

Pull box and pre-fabricated bus connectors are supplied to match the sandwich type bus duct end flange. Bus duct is assumed to enter the top. Bus duct type and orientation to the MCC must be provided.

Table 29.1-5. Bus Duct Entry to Horizontal Bus or Main Disconnect—Pull Box—Dimensions in Inches (mm) ⑦

Horizontal Bus Rating (Amperes)	Pull Box Height
600–1600	18.00 (457.2)
2000–2500 ⑧	24.00 (609.6)

- ⑦ Not available in Freedom Arc-Resistant.
- ⑧ Contact Eaton for 3200 A dimensions.

Note: Consult factory for non-segregated bus requirements.

Main Devices

Incoming Line

Incoming line cables entering the MCC from either the top or bottom can be easily terminated onto main lugs or connected to a main disconnect. All incoming line sections comply with NEC wiring bending requirements as adopted by UL.

Table 29.1-6. Main Lug Only and Sub-Feed Lug Compartments (Three-Phase, Three- or Four-Wire)—Dimensions in Inches (mm)

Provisions for terminating incoming line cables directly onto the MCC bus system. Up to 1200 A, all lug landings are bolted to a fully rated vertical bus in that section. MLO sections must be put at the top for top entry cables and at the bottom for bottom entry cables. For smaller cable sizes, cable lugs may also be extended into an optional top hat. Consult factory for this option.

Maximum Cable Size (kcmil)	Maximum Cables per Phase	Cable Entry (Top or Bottom)	Lug Type	Unit Height ①	X Space ①	Unit Height with Meter CTs ①	X-Space with Meter CTs ①	Enclosure Width
350	2	Either	Screw Crimp	12.00 (304.8)	2X	24.00 (609.6)	4X	② 20 (508.0)
				18.00 (457.2)	3X	30.00 (762.0)	5X	
	4	Top	Screw Crimp	18.00 (457.2)	3X	36.00 (914.4)	6X	
Bottom		Screw Crimp	36.00 (914.4)	6X	54.00 (1371.6)	9X		
600	2	Either	Screw Crimp	18.00 (457.2)	3X	30.00 (762.0)	5X	
				24.00 (609.6)	4X	36.00 (914.4)	6X	
	4	Top	Screw Crimp	24.00 (609.6)	4X	42.00 (1066.8)	7X	
Bottom		Screw Crimp	36.00 (914.4)	6X	54.00 (1371.6)	9X		
750	2	Either	Screw Crimp	24.00 (609.6)	4X	42.00 (1066.8)	7X	
				36.00 (914.4)	6X	54.00 (1371.6)	9X	
	4	Either	Screw Crimp	36.00 (914.4)	6X	54.00 (1371.6)	9X	
72.00 (1828.8)				12X ③	72.00 (1828.8)	12X ③		
8	Either	Screw Crimp	72.00 (1828.8)	12X ③	72.00 (1828.8)	12X ③		
			72.00 (1828.8)	12X ③	72.00 (1828.8)	12X ③		
1000	2	Either	Screw Crimp	30.00 (762.0)	5X	54.00 (1371.6)	9X	
				36.00 (914.4)	6X	72.00 (1828.8)	12X ③	
	8	Either	Screw Crimp	72.00 (1828.8)	12X ③	72.00 (1828.8)	12X ③	
72.00 (1828.8)				12X ③	72.00 (1828.8)	12X ③		

① For 1600 A and above bus, all lug compartments are 72.00 (1828.8), 12X

② 3200 A bus requires 24.00 (609.6) wide enclosure.

③ Lug landings require the complete vertical section. The rear is unusable.

Table 29.1-7. Main Circuit Breakers—Molded Case Circuit Breakers—Dimensions in Inches (mm) ①②

Frames reflect standard circuit breakers. Unit spacings shown include sufficient space to terminate cables on any standard breaker lug. If cable sizes exceed those listed, lug adapters are available and require extra spacing. Consult factory.

Frame Size (Amperes)	Circuit Breaker Frame	Interrupting Capacity (kAIC)			Unit Height	X Space	Unit Height with Meter CTs	X-Space with Meter CTs	Standard Lugs Supplied ③
		240V	480V	600V					
125	E125H	65	65	65	6.00 (152.4)	1X	18.00 (457.2)	3X	#3/0 AWG
150	HFD	65	65	25	12.00 (304.8)	2X	24.00 (609.6)	4X	#1/0 AWG
	FDC	100	100	35 ④	12.00 (304.8)	2X	24.00 (609.6)	4X	#1/0 AWG
225	HFD	65 ④	65 ④	25 ④	18.00 (457.2)	3X	30.00 (762.0)	5X	300 kcmil
	FDC	100	100	35	18.00 (457.2)	3X	30.00 (762.0)	5X	300 kcmil
250	J250H	65	65	—	6.00 (152.4)	1X	18.00 (457.2)	3X	350 kcmil
	HJD	65	65	25	30.00 (762.0)	5X	42.00 (1066.8)	7X	350 kcmil
	JDC	100	100	35	30.00 (762.0)	5X	42.00 (1066.8)	7X	350 kcmil
400	HKD	65	65	35	30.00 (762.0)	5X	42.00 (1066.8)	7X	2–250 kcmil
	CHKD ⑤	65	65	35	30.00 (762.0)	5X	42.00 (1066.8)	7X	2–250 kcmil
	KDC	100	100	50	30.00 (762.0)	5X	42.00 (1066.8)	7X	2–250 kcmil
600	HLD	65	65	35	30.00 (762.0) ⑥	5X ⑥	42.00 (1066.8) ⑦	7X ⑦	2–500 kcmil
	CHLD ⑤	65	65	35	30.00 (762.0) ⑥	5X ⑥	42.00 (1066.8) ⑦	7X ⑦	2–500 kcmil
	LGH	65	65	—	30.00 (762.0)	5X	42.00 (1066.8)	7X	2–500 kcmil
	LDC	100	100	50	30.00 (762.0) ⑥	5X ⑥	42.00 (1066.8) ⑦	7X ⑦	2–500 kcmil
	CLDC ⑤	100	100	50	30.00 (762.0) ⑥	5X ⑥	42.00 (1066.8) ⑦	7X ⑦	2–500 kcmil
800	HMDL	65	65	35	30.00 (762.0)	5X	48.00 (1219.2)	8X	2–750 kcmil
	CHMDL	65	65	35	48.00 (1219.2)	8X	66.00 (1676.4)	11X	2–750 kcmil
1200	NGH	65	65	35	42.00 (1066.8)	7X	60.00 (1524.0)	10X	4–500 kcmil
	NGH-C ⑤	65	65	35	72.00 (1828.8)	12X	72.00 (1828.8)	12X	4–500 kcmil
	NGC	100	100	50	42.00 (1066.8)	7X	60.00 (1524.0)	10X	4–500 kcmil
	NGC-C ⑤	100	100	50	72.00 (1828.8)	12X	72.00 (1828.8)	12X	4–500 kcmil
2000	RGH	65	65	50	72.00 (1828.8)	12X	72.00 (1828.8)	12X	6–600 kcmil
	RGH-C ⑤	65	65	50	72.00 (1828.8)	12X	72.00 (1828.8)	12X	6–600 kcmil
	RGC	65	65	50	72.00 (1828.8)	12X	72.00 (1828.8)	12X	6–600 kcmil
	RGC-C ⑤	65	65	50	72.00 (1828.8)	12X	72.00 (1828.8)	12X	6–600 kcmil
2500 ⑧	RGH	65	65	50	72.00 (1828.8)	12X	72.00 (1828.8)	12X	6–600 kcmil
	RGC	65	65	50	72.00 (1828.8)	12X	72.00 (1828.8)	12X	6–600 kcmil

- ① RotoTract not available on main devices.
- ② Refer to breaker literature for available trip unit and accessory options.
- ③ See circuit breaker terminal data for variations.
- ④ 100 kAIC with current limiter attachment.
- ⑤ 100% rated breaker. Not available in Arc Resistant or NEMA 12.
- ⑥ Bottom-entry requires 24.00 (609.6), 4X.
- ⑦ Bottom-entry requires 36.00 (914.4), 6X.
- ⑧ Requires a 24.00 (609.6) wide section.

Table 29.1-8. Main Circuit Breakers—Magnum DS Air Circuit Breakers Manually or Electrically Operated—Fixed Mounted—Dimensions in Inches (mm)

Frame Size Amperes	Circuit Breaker Type	Interrupting Capacity (kAIC)			Unit Size	Enclosure Width	Enclosure Depth
		240V	480V	575V			
800	MDS-608	65	65	65	72.00 (1828.8)	24.00 (609.6)	21.00 (533.4)
	MDS-C08	100	100	100	72.00 (1828.8)	24.00 (609.6)	21.00 (533.4)
1600	MDS-616	65	65	65	72.00 (1828.8)	24.00 (609.6)	21.00 (533.4)
	MDS-C16	100	100	100	72.00 (1828.8)	24.00 (609.6)	21.00 (533.4)
2000	MDS-620	65	65	65	72.00 (1828.8)	24.00 (609.6)	21.00 (533.4)
	MDS-C20	100	100	100	72.00 (1828.8)	24.00 (609.6)	21.00 (533.4)

Note: Refer to breaker literature for available trip unit and accessory options.

Table 29.1-9. Main Circuit Breakers—Magnum DS Air Circuit Breakers, Manually or Electrically Operated—Drawout Mounted—Dimensions in Inches (mm) ①

Frame Size (Amperes)	Circuit Breaker Type	Interrupting Capacity (kAIC)			Unit Size	Enclosure Width	Enclosure Depth
		240 V	480 V	575 V			
800	MDS-608	65	65	65	72.00 (1828.8)	24.00 (609.6) ②	42.00 (1066.8) ③
	MDS-C08	100	100	100	72.00 (1828.8)	24.00 (609.6) ②	42.00 (1066.8) ③
1600	MDS-616	65	65	65	72.00 (1828.8)	24.00 (609.6) ②	42.00 (1066.8) ③
	MDS-C16	100	100	100	72.00 (1828.8)	24.00 (609.6) ②	42.00 (1066.8) ③
2000	MDS-620	65	65	65	72.00 (1828.8)	24.00 (609.6) ②	42.00 (1066.8) ③
	MDS-C20	100	100	100	72.00 (1828.8)	24.00 (609.6) ②	42.00 (1066.8) ③
3200	MDS-632	65	65	65	72.00 (1828.8)	24.00 (609.6) ②	42.00 (1066.8) ③
	MDS-C32	100	100	100	72.00 (1828.8)	24.00 (609.6) ②	42.00 (1066.8) ③

① Not available in Freedom Arc-Resistant .

② A 4.00-inch (101.6 mm) filler section must be added between the main and the rest of the MCC to allow for door opening.

③ Structure is rear aligned.

Note: Refer to breaker literature for available trip unit and accessory options.

Table 29.1-10. Main Incoming Fusible Switches—Dimensions in Inches (mm) ④⑤

Three-pole—250 V or 600 Vac. Fuses not included.

Switch Rating (Amperes)	Switch Type	Fuse Clip Size (Amperes)	Available Fuse Types	Unit Height	X Space	Unit Height with Meter CTs	X Space with Meter CTs
100	K-SW	100	R, J	18.00 (457.2)	3X	30.00 (762.0)	5X
200	K-SW	200	R, J	30.00 (762.0)	5X	42.00 (1066.8)	7X
400	K-SW	400	R, J	48.00 (1219.2)	8X	60.00 (1524.0)	10X
600	K-SW	600	R, J	54.00 (1371.6)	9X ⑥	72.00 (1828.8)	12X
800	K-SW	800	L	54.00 (1371.6)	9X ⑥	72.00 (1828.8)	12X
1200	Hi-Mag MCS ⑦	1200	L	60.00 (1524.0)	10X	72.00 (1828.8)	12X

④ All fusible mains have a 100 kAIC interrupting capacity.

⑤ Not available in Freedom Arc-Resistant.

⑥ Bottom-entry requires 60.00 (1524.0), 10X.

⑦ Fuse block supplied in series with molded case switch to obtain UL short-circuit rating

Surge Protective Devices

SPD Series

Eaton’s SPD Series surge protective devices are the latest and most advanced UL 1449 3rd Edition certified surge protectors. Application of SPD Series units throughout a facility will ensure that equipment is protected with the safest and most reliable surge protective devices available.

SPD Series units are available in all common voltages and configurations, and also in a variety of surge current capacity ratings from 50 kA through 400 kA. Three feature package options are also available to choose from.



Table 29.1-11. SPD (Surge Protective Device) with Circuit Breaker Disconnect
Three feature packages are available:

- Basic—includes dual-colored protection status indicators for each phase.
- Standard—includes the features of basic, plus an audible alarm with silence button, one Form C relay contact and up to 50 dB of noise attenuation from 10 kHz to 100 MHz.
- Standard with surge counter—includes all of the features of basic plus a surge counter with reset button.

Description	Unit Space ①	
	Inches (mm)	X Space
Surge Current Per Phase		
100 kA SPD-100	18.00 (457.2)	3X
120 kA SPD-120 (recommended branch unit)	18.00 (457.2)	3X
160 kA SPD-160	18.00 (457.2)	3X
200 kA SPD-200	18.00 (457.2)	3X
250 kA SPD-250 (recommended service entrance)	18.00 (457.2)	3X
300 kA SPD-300	18.00 (457.2)	3X
400 kA SPD-400	18.00 (457.2)	3X

① Also available in 12.00-inch (304.8 mm) unit (2X) without circuit breaker disconnect.

Metering and Bus Protection



Table 29.1-12. Metering and Bus Protection—Dimensions in Inches (mm) ①②
Power Xpert 4000/6000/8000 meters are available with communication features for power management and system software integration in addition to a Web interface. Customers and facility personnel can view the metering data using a standard PC Web browser. The new platform offers advanced functionality like transient capture, high sampling rate, open communications, Web server gateway, field-upgradable firmware, expandable memory and optional I/O.

Type	Description	Unit Height	X Space
Analog meters	Ammeter	12.00 (304.8)	2X
	Ammeter with switch	12.00 (304.8)	2X
	Voltmeter	12.00 (304.8)	2X
	Voltmeter with switch	12.00 (304.8)	2X
	Ammeter/Voltmeter	12.00 (304.8)	2X
	Ammeter/Voltmeter with switch	12.00 (304.8)	2X
Digital meters	PXM1000	12.00 (304.8)	2X
	PXM3000	12.00 (304.8)	2X
	PXM4000 ③	24.00 (609.6)	4X
	PXM6000 ③	24.00 (609.6)	4X
	PXM8000 ③	24.00 (609.6)	4X

Voltage Protection

SPD (See Table 29.1-11)	18.00 (457.2)	3X
Ground detection lights—three-phase ungrounded system	6.00 (152.4)	1X
System voltage monitor—D65VAKPA3	6.00 (152.4)	1X

High Resistance Ground System

Current sensing	Requires 21.00 (533.4) deep, 20.00 (508.0) wide structure	72.00 (1828.8)	12X
Voltage sensing	without a vertical wireway	72.00 (1828.8)	12X

- ① Metering CTs will require additional unit space in the main incoming sections. Refer to Table 29.1-6, Table 29.1-7 and Table 29.1-10 for more information.
- ② UL listed third-party meters can also be installed in Eaton MCCs. Consult factory for details.
- ③ Supplied with door-mounted display as standard.

Power Factor Correction Capacitors

Table 29.1-13. Power Factor Correction Capacitors

PF capacitors are electrolytic type and are optionally available with external line fuses and blown fuse indicators. Capacitors' sizes must be specified by the customer.

Caution: Capacitors on the main bus of the MCC may affect solid-state equipment. Please consult factory.

kvar Rating	208V Unit Space		240V Unit Space		600V Unit Space	
	Inches (mm)	X Space	Inches (mm)	X Space	Inches (mm)	X Space
2	12.00 (304.8)	2X	12.00 (304.8)	2X	12.00 (304.8)	2X
3	12.00 (304.8)	2X	12.00 (304.8)	2X	12.00 (304.8)	2X
4	12.00 (304.8)	2X	12.00 (304.8)	2X	12.00 (304.8)	2X
5	12.00 (304.8)	2X	12.00 (304.8)	2X	12.00 (304.8)	2X
7.5	12.00 (304.8)	2X	12.00 (304.8)	2X	12.00 (304.8)	2X
10	12.00 (304.8)	2X	12.00 (304.8)	2X	12.00 (304.8)	2X
15	12.00 (304.8)	2X	12.00 (304.8)	2X	12.00 (304.8)	2X
20	24.00 (609.6)	4X	12.00 (304.8)	2X	12.00 (304.8)	2X
22.5	24.00 (609.6)	4X	12.00 (304.8)	2X	12.00 (304.8)	2X
25	—	—	24.00 (609.6)	4X	12.00 (304.8)	2X
30	—	—	24.00 (609.6)	4X	12.00 (304.8)	2X
40	—	—	—	—	12.00 (304.8)	2X
50	—	—	—	—	24.00 (609.6)	4X
60	—	—	—	—	24.00 (609.6)	4X
75	—	—	—	—	24.00 (609.6)	4X
90	—	—	—	—	24.00 (609.6)	4X
100	—	—	—	—	36.00 (914.4)	6X
120	—	—	—	—	36.00 (914.4)	6X

Feeder Tap Units



Freedom Dual Feeder Tap Unit

Feeder tap units are available with either molded case circuit breakers, Magnum DS power circuit breakers or fusible switches.

Molded case circuit breaker units are available as drawout up to 400 A, with dual-mounting available up to 150 A. Molded case circuit breaker units above 400 A and up to 2500 A are fixed mounted.

Magnum DS circuit breaker units are available as either fixed mounted up to 2000 A or drawout up to 3200 A.

Fusible feeder tap units use Eaton’s Type K visible blade disconnect switch. Fused switches are mounted in drawout units through 400 A with 30 A and 60 A ratings available in dual mountings. Fixed-mounted switch ratings of 600 A and 800 A are also available. All switches are supplied with fuse clips for use with current limiting or dual-element rejection type. Types of fuses include Class J, R or L, which are supplied by “others.”

Table 29.1-14. Feeder Tap Units—Molded Case Circuit Breakers—Dimensions in Inches (mm) ①

Frames reflect standard circuit breakers. Unit spacings shown include sufficient space to terminate cables on any standard breaker lug. If cable sizes exceed those listed, lug adapters are available and require extra spacing. Consult factory.

Frame Size (Amperes)	Circuit Breaker Frame	Interrupting Capacity (kAIC)			Unit Height	X Space	Unit Height with RotoTract	X Space with RotoTract	Standard Lugs Supplied ②
		240V	480V	600V					
125	E125H	65	65	65	6.00 (152.4)	1X	12.00 (304.8)	2X	#3/0 AWG
150	HFD	65	65	25	12.00 (304.8)	2X	12.00 (304.8)	2X	#1/0 AWG
	HFDE (80AF)	65	65	25	12.00 (304.8)	2X	12.00 (304.8)	2X	#1/0 AWG
	FDC	100	100	35 ③	12.00 (304.8)	2X	12.00 (304.8)	2X	#1/0 AWG
150 (dual-mounted)	HFD	65	65	25	12.00 (304.8)	2X	—	—	#1/0 AWG
	HFDE (80AF)	65	65	25	12.00 (304.8)	2X	—	—	#1/0 AWG
	FDC	100	100	35 ③	12.00 (304.8)	2X	—	—	#1/0 AWG
225	HFD	65 ③	65 ③	25 ③	18.00 (457.2)	3X	12.00 (304.8)	2X	300 kcmil
	HFDE	65	65	25	18.00 (457.2)	3X	12.00 (304.8)	2X	301 kcmil
	FDC	100	100	35	18.00 (457.2)	3X	12.00 (304.8)	2X	300 kcmil
250	J250H	65	65	—	6.00 (152.4)	1X	12.00 (304.8)	2X	350 kcmil
	HJD	65	65	25	18.00 (457.2)	3X	—	—	350 kcmil
	JDC	100	100	35	18.00 (457.2)	3X	—	—	350 kcmil
400	HKD	65	65	35	24.00 (609.6)	4X	30.00 (762.0)	5X	2–250 kcmil
	CHKD ④	65	65	35	24.00 (609.6)	4X	30.00 (762.0)	5X	2–250 kcmil
	KDC	100	100	50	24.00 (609.6)	4X	30.00 (762.0)	5X	2–250 kcmil
600	HLD	65	65	35	30.00 (762.0) ⑤	5X ⑤	—	—	2–500 kcmil
	CHLD ④	65	65	35	30.00 (762.0) ⑤	5X ⑤	—	—	2–500 kcmil
	LGH	65	65	—	30.00 (762.0)	5X	—	—	2–500 kcmil
	LDC	100	100	50	30.00 (762.0) ⑤	5X ⑤	—	—	2–500 kcmil
	CLDC ④	100	100	50	30.00 (762.0) ⑤	5X ⑤	—	—	2–500 kcmil
800	HMDL	65	65	35	30.00 (762.0)	5X	—	—	2–750 kcmil
	CHMDL	65	65	35	48.00 (1219.2)	8X	—	—	2–750 kcmil
1200	NGH	65	65	35	42.00 (1066.8)	7X	—	—	4–500 kcmil
	NGH-C ④	65	65	35	72.00 (1828.8)	12X	—	—	4–500 kcmil
	NGC	100	100	50	42.00 (1066.8)	7X	—	—	4–500 kcmil
	NGC-C ④	100	100	50	72.00 (1828.8)	12X	—	—	4–500 kcmil
2000	RGH	65	65	50	72.00 (1828.8)	12X	—	—	6–600 kcmil
	RGH-C ④	65	65	50	72.00 (1828.8)	12X	—	—	6–600 kcmil
	RGC	65	65	50	72.00 (1828.8)	12X	—	—	6–600 kcmil
	RGC-C ④	65	65	50	72.00 (1828.8)	12X	—	—	6–600 kcmil
2500 ⑥	RGH	65	65	50	72.00 (1828.8)	12X	—	—	6–600 kcmil
	RGC	65	65	50	72.00 (1828.8)	12X	—	—	6–600 kcmil

① Refer to breaker literature for available trip unit and accessory options.

② See circuit breaker terminal data for variations.

③ 100 kAIC with current limiter attachment.

④ 100% rated breaker. Not available in Arc-Resistant or NEMA 12.

⑤ Bottom-entry requires 24.00 (609.6), 4X.

⑥ Requires a 24.00 (609.6) wide section.

Table 29.1-15. Feeder Tap Units—Magnum DS Air Circuit Breakers Manually or Electrically Operated—Fixed Mounted—Dimensions in Inches (mm)

Frame Size (Amperes)	Circuit Breaker Type	Interrupting Capacity (kAIC)			Unit Size	Enclosure Width	Enclosure Depth
		240 V	480 V	575 V			
800	MDS-608	65	65	65	72.00 (1828.8)	24.00 (609.6)	21.00 (533.4)
	MDS-C08	100	100	100	72.00 (1828.8)	24.00 (609.6)	21.00 (533.4)
1600	MDS-616	65	65	65	72.00 (1828.8)	24.00 (609.6)	21.00 (533.4)
	MDS-C16	100	100	100	72.00 (1828.8)	24.00 (609.6)	21.00 (533.4)
2000	MDS-620	65	65	65	72.00 (1828.8)	24.00 (609.6)	21.00 (533.4)
	MDS-C20	100	100	100	72.00 (1828.8)	24.00 (609.6)	21.00 (533.4)

Table 29.1-16. Feeder Tap Units—Magnum DS Air Circuit Breakers Manually or Electrically Operated—Drawout Mounted—Dimensions in Inches (mm) ①

Frame Size (Amperes)	Circuit Breaker Type	Interrupting Capacity (kAIC)			Unit Size	Enclosure Width	Enclosure Depth
		240 V	480 V	575 V			
800	MDS-608	65	65	65	72.00 (1828.8)	24.00 (609.6) ②	42.00 (1066.8) ③
	MDS-C08	100	100	100	72.00 (1828.8)	24.00 (609.6) ②	42.00 (1066.8) ③
1600	MDS-616	65	65	65	72.00 (1828.8)	24.00 (609.6) ②	42.00 (1066.8) ③
	MDS-C16	100	100	100	72.00 (1828.8)	24.00 (609.6) ②	42.00 (1066.8) ③
2000	MDS-620	65	65	65	72.00 (1828.8)	24.00 (609.6) ②	42.00 (1066.8) ③
	MDS-C20	100	100	100	72.00 (1828.8)	24.00 (609.6) ②	42.00 (1066.8) ③
3200	MDS-632	65	65	65	72.00 (1828.8)	24.00 (609.6) ②	42.00 (1066.8) ③
	MDS-C32	100	100	100	72.00 (1828.8)	24.00 (609.6) ②	42.00 (1066.8) ③

① Not available in Arc-Resistant.

② A 4.00 (101.6) wide filler section must be added between the section and the rest of the MCC to allow for door opening.

③ Structure is rear aligned.

Table 29.1-17. Feeder Tap Units—Fusible Switches—Dimensions in Inches (mm) ④⑤

Three-pole—250 V or 600 Vac. Fuses not included.

Switch Rating (Amperes)	Switch Type	Fuse Clip Size (Amperes)	Available Fuse Types	Unit Height	X Space	Unit Height with RotoTract	X Space with RotoTract
30	K-SW	30	R, J	12.00 (304.8)	2X	18.00 (457.2)	3X
60	K-SW	60	R, J	12.00 (304.8)	2X	18.00 (457.2)	3X
100	K-SW	100	R, J	18.00 (457.2)	3X	24.00 (609.6)	4X
200	K-SW	200	R, J	30.00 (762.0)	5X	36.00 (914.4)	6X
400	K-SW	400	R, J	42.00 (1066.8)	7X	42.00 (1066.8)	7X
600	K-SW	600	R, J	48.00 (1219.2)	8X	—	—
800	K-SW	800	L	54.00 (1371.6)	9X ⑥	—	—
1200	Hi-Mag MCS ⑦	1200	L	60.00 (1524.0)	10X	—	—

④ All fusible feeders have a 100 kAIC interrupting capacity.

⑤ Not available in Freedom Arc-Resistant.

⑥ Bottom-entry requires 48.00 (1219.2), 8X.

⑦ Fuse block supplied in series with molded case switch to obtain UL short-circuit rating.

Automatic Transfer Switches



Table 29.1-18. Automatic Transfer Switches—Dimensions in Inches (mm)

Ampere Rating	Switch Type	Interrupting Rating (kA)	Unit Height	X Space	Enclosure Width
100	Eaton ATH9 ①	65	48.00 (1219.2)	8X	20.00 (508.0)
150	Eaton ATH9 ①	65	48.00 (1219.2)	8X	20.00 (508.0)
225	Eaton ATV9 ①	65	48.00 (1219.2)	8X	20.00 (508.0)
300	Eaton ATV9 ①	65	48.00 (1219.2)	8X	20.00 (508.0)
400	Eaton ATV9 ①	65	72.00 (1828.8)	12X	20.00 (508.0)
600	Eaton ATV9 ①	65	72.00 (1828.8)	12X	24.00 (609.6)
800	Eaton ATV9 ①	50	72.00 (1828.8)	12X	24.00 (609.6)
1000	Eaton ATV9 ①	50	72.00 (1828.8)	12X	24.00 (609.6)
100	ASCO 7000 ②	65	36.00 (914.4)	6X	20.00 (508.0)
150	ASCO 7000 ②	65	36.00 (914.4)	6X	20.00 (508.0)
250	ASCO 7000 ②	65	54.00 (1371.6)	9X	24.00 (609.6)
400	ASCO 7000 ②	35	54.00 (1371.6)	9X	24.00 (609.6)
600	ASCO 7000 ②	35	72.00 (1828.8)	12X	24.00 (609.6)
800	ASCO 7000 ②	50	72.00 (1828.8)	12X	36.00 (914.4)
1000	ASCO 7000 ②	50	72.00 (1828.8)	12X	36.00 (914.4)
1200	ASCO 7000 ②	100	72.00 (1828.8)	12X	40.00 (1016.0)

- ① Includes ATC-900 controller as standard. ATC-300 controller available as an option.
- ② Requires 42.00-inch (1066.8 mm) deep structure.

Dry-Type Transformers

Table 29.1-19. Dry-Type Distribution Transformers

- Transformer 1.0–2.0 kVA will include a circuit breaker and fuses in a standard 2X unit
- Transformers 3.0 kVA and above have taps and electrostatic shields as standard
- Transformers 3.0 kVA and above will include the primary and secondary circuit breakers housed behind a single door

kVA Rating	Unit Space	Primary Breaker (Included in Space Factor)		Secondary Breaker ③ (Included in Space Factor)
		230V	480V	

Single-Phase

0.5	2X	15	15	—
0.75	2X	15	15	—
1	2X	15	15	—
1.5	2X	15	15	—
2	2X	15	15	—
3	4X	15	15	20
5	4X	15	15	30
7.5	4X	20	20	40
10	4X	25	30	60
15	5X	40	40	90
20	5X	50	60	125
25	5X	60	70	150
30	6X	70	80	175
45	7X	100	125	250

Three-Phase

9	5X	15	15	40
15	5X	20	25	60
25	6X	40	40	90
30	6X	40	50	125
45	6X	60	70	175

- ③ Transformers feeding an MCC mounted panelboard require a secondary breaker.

Panelboards



Panelboards

Table 29.1-20. Lighting Panelboards 120/240 V or 120/208 V Lighting Panelboards Type—PRL1A

Fixed mounted, main lug only panelboards can be either 120/240 V, single-phase, three-wire; 208Y/120 V, three-phase, four-wire.

Number of Circuits	Chassis Rating (Amperes)		Unit Space Inches (mm)	
	Single-Phase Three-Wire	Three-Phase Four-Wire	Single-Phase Three-Wire	Three-Phase Four-Wire
18	100	100	24.00 (609.6) or 4X	24.00 (609.6) or 4X
30	225	100	30.00 (762.0) or 5X	30.00 (762.0) or 5X
42	225	225	36.00 (914.4) or 6X	36.00 (914.4) or 6X

Note: For MCB, back-feed panelboard branch circuit breaker, or select separate feeder unit. Bolt-on single-, two-, three-pole breakers only.

Table 29.1-21. 277/480 V or 480/600 V Lighting Panelboards Type—PRL3A

Fixed mounted, main lug only panelboards can be either 480 or 600 V, three-phase, three-wire or 480Y/277 V, three-phase, four-wire. Mounted in bottom portion of structure.

Number of Circuits	Chassis Rating (Amperes)	Unit Space Inches (mm)	
		Three-Phase Three-Wire	Three-Phase Four-Wire
14	100	—	36.00 (914.4) or 6X
18	250	36.00 (914.4) or 6X	—
24	100	36.00 (914.4) or 6X	—
26	250	—	48.00 (1219.2) or 8X
32	100	—	48.00 (1219.2) or 8X
36	250	48.00 (1219.2) or 8X	—
42	100	48.00 (1219.2) or 8X	60.00 (1524.0) or 10X
42	250	60.00 (1524.0) or 10X	60.00 (1524.0) or 10X
12	400/600	36.00 (914.4) or 6X	—
14	400/600	—	48.00 (1219.2) or 8X
30	400/600	48.00 (1219.2) or 8X	60.00 (1524.0) or 10X
42	400/600	60.00 (1524.0) or 10X	72.00 (1828.8) or 12X

Note: For MCB, back-feed panelboard branch circuit breaker, or select separate feeder unit.

Note: Either plug-in or bolt-on single-, two-, three-pole breakers only.

Table 29.1-22. Lighting Panelboard Circuit Breakers

Eaton’s circuit breakers can be either plug-in or bolt-on, single-, two- or three-pole through 240 V. 600 V maximum single-, two- or three-pole circuit breakers are bolt-on.

Poles	Maximum Voltage	Plug-in	Bolt-on	Ampere Interrupting Capacity
1/2/3	240	HQP	BAB	10,000
1/2/3	240	QPHW	QBHW	22,000
1/2/3	600	—	EHD	14,000
1/2/3	600	—	HFD	65,000

Units

General

Motor starter units are combination type employing a linestarter and a disconnect device of proven capability. The disconnect device can be a High interrupting Motor Circuit Protector (HMCP), Thermal-Magnetic (TM) breaker or fusible switch. Eaton’s Type HMCP and HMCPE motor circuit protectors are furnished as standard.

All starters and soft starters through NEMA Size 5 are a drawout design except Size 5 electromechanical reduced voltage. Size 5 optionally can be bolt-in if requested.

All feeder breakers through 400 A are a drawout design.

All dimensions and ratings in the following tables are based on NEMA Design B, 1800 RPM motors.

The HMCP/HMCPE and starter combination has a 65,000 rms symmetrical ampere short-circuit current rating as standard at 480 V. Starter units are available with optional 100,000 A short-circuit current rating. Series C® thermal-magnetic circuit breakers (65 kAIC, or optional 100 kAIC) for starter units are also available.

All starters meet or exceed IEC 947-4 Type II testing with HMCP, or R and J fuses (Freedom Arc-Resistant is HMCP only).

The fusible switch disconnect device is the Type K. It is a quick-make, quick-break, visible blade switch with fuse clips for use with current-limiting or dual element, rejection type, NEMA Class J or R fuses. Rejection fuse clips for Class RK-5 fuses are standard. Fuses are not included as standard.

Both breaker and fuse selection must take into consideration the total short-circuit capacity of the system to which the control center is connected. For a fused switch and starter combination, a 100 kA SCCR at 600 V can be achieved.

Typical starter units available include the following:

- Full voltage, non-reversing
- Full voltage, reversing
- Two-speed, single winding and two winding
- Reduced voltage, autotransformer, closed transition
- Reduced voltage, wye delta, open or closed transition
- Reduced voltage, part winding
- Reduced voltage, solid-state (RVSS)
- Adjustable frequency drives (AFD)

Each starter includes a stainless steel corrosion-resistant safety ground clip that makes connection before the power stabs engage the vertical bus.

Units—Freedom and Freedom Arc-Resistant

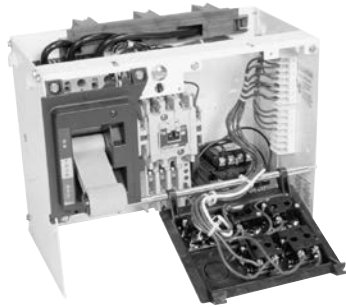

Freedom FVNR Starter

Freedom and Freedom Arc-Resistant starter units are equipped with Eaton's Freedom starters and contactors NEMA Sizes 1 through 5. Size 6 and 7 starters are A200 type. These contactors have been successfully applied in thousands of the most demanding industrial applications. Overload protection is provided by a three-pole adjustable ambient compensated, bi-metallic thermal overload relay. The overload relay also provides single-phase sensitivity and isolated alarm contact. As an option, the overload relay can be upgraded to a standard solid-state overload or an advanced solid-state overload as described on **Page 29.1-40**. An insulated hand reset button extends through the compartment door. Additionally, motor running data and starter status/control are available through one of the many industrial standard communication protocols. Freedom Arc-Resistant adds line and load shields to the disconnect.

Freedom and Freedom Arc Resistant Stab Assembly

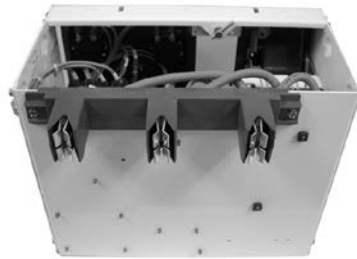

Freedom Plug-in Unit Bus Stabs

A tin-plated copper alloy stab incorporates the ultimate in mechanical simplicity to provide precise control of contact pressure on the bus.

This ensures a positive connection yet permits easy unit insertion and withdrawal.

Self-aligning stabs are mounted in a glass-reinforced plastic insulation block that totally shrouds each stab and absolutely ensures positive alignment of the stabs with the vertical bus. The insulation block is also an integral part of the phase-to-phase isolation system. Power wiring is welded to the stabs and is totally contained within the unit enclosure. This means the vertical bus compartment is completely free of wiring for maximum safety and reliability.

Stab assemblies are accurately matched to the electrical requirements of each individual unit and are provided in 60, 150, 300 or 400 A ratings (plug-in through Size 5).

Freedom and Freedom Arc-Resistant Handle Mechanism



Circuit Breaker Handle Mechanism

The handle mechanism is designed to provide a high mechanical leverage so that little effort is required to operate any device.

The standard handle mechanism is a vertical motion type device with four positions: ON, OFF, TRIPPED and RESET. Only circuit breaker types have tripped and reset positions. It is securely mounted to the front of the unit and mechanically connected to the breaker or fusible switch, eliminating alignment problems. It provides a positive indication of the breaker or switch position, even with the door open.

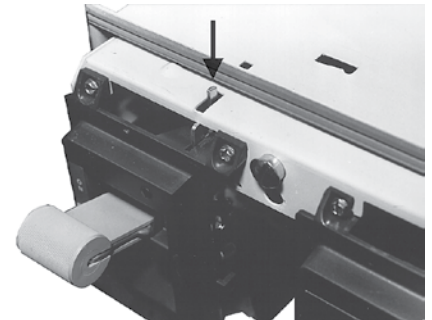

Unit Insertion Interlock

The handle and exterior front panel are molded from the same plastic material as the device panel. A textured surface preserves the appearance. The ON position indicator is at the top and is a bright red. The OFF/RESET position is at the bottom and is bright green. The TRIP position, a bright yellow, is in the middle, between the ON and OFF position. All position indicator colors contrast with the black background and are highly visible even at considerable distances. The operating handle is designed for rugged duty and solid operator feel.



Padlocking Bar

The handle mechanism provides several safety features:

- In the ON position, an interlock prevents the unit door from being opened. A door interlock defeater screw located above the handle is provided to enable authorized maintenance personnel access to the units when required
- With the unit door open and the operating handle in the ON position, an interlock slides into a slot in the divider pan above and prevents removal of the unit. This same interlock prevents insertion of the unit unless the handle mechanism is in the OFF position. The interlock also prevents the operating handle from being turned on with the unit door open
- To ensure that units are not energized accidentally or by unauthorized personnel, the handle mechanism can be padlocked in the OFF position. Sufficient space is available for a maximum of three padlocks. Where critical processes are involved and to prevent unauthorized shutdown, the handle mechanism can be modified to enable padlocking in the ON position

Freedom and Freedom Arc-Resistant Device Panel



Standard Device Panel

The device panel can accommodate up to six 1-3/16-inch (30.2 mm) Eaton's 10250T type pilot devices such as oiltight pushbuttons, indicating lights, selector switches and miniature meters.

Molded into the panel is a knockout for each device location. This facilitates the future addition of devices to the panel.

The device panel is hinged on a horizontal pivot tube extending across the front of the unit. With the unit door open, loosening two captive retaining screws at the top of the panel and sliding it 0.50-inch (12.7 mm) left, permits it to swing down. This provides ready access to the rear of the panel and increased accessibility to the unit interior.

Nameplates

Unit nameplates are 1.00 x 2.50 inches (25.4 x 63.5 mm) and engraved with 3/16-inch (4.8 mm) high white lettering on a black background (black lettering on a white background optional). They are heat- and crack-resistant to eliminate the need for replacement. Nameplates are mounted with stainless steel self-tapping screws.

Freedom and Freedom Arc-Resistant Unit Wrapper

The unit wrapper is equipped with a quarter-turn side wrapper latch that securely holds the unit in the compartment. The latch can only be engaged when the stabs are fully mated with the vertical bus. Upon release of the latch, the unit can be partially withdrawn such that the stabs disengage from the vertical bus. In this position, the latch can be re-engaged to prevent the unit from being returned to the fully stabbed position or from being removed from the structure. The latch can be padlocked in this position to ensure that the stabs remain disengaged during maintenance.

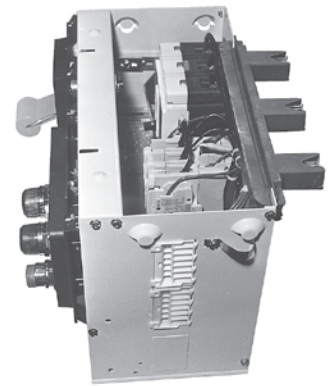

Freedom Plug-in Unit Wrapper

Units—DC Starters



DC Starter Unit

UL listed DC MCCs use combination circuit breaker DC starters suitable for motor starting duty only. Using Eaton’s Type ME DC definite purpose contactors, all DC starters are suitable for up to 250 Vdc and have a 22 kA withstand rating. Class 135 starting resistors for reduced voltage starters are sized for 200% starting current. Typical applications include emergency lube oil pumps, emergency seal oil pumps and emergency turning gear motors.

Units—Freedom FlashGard

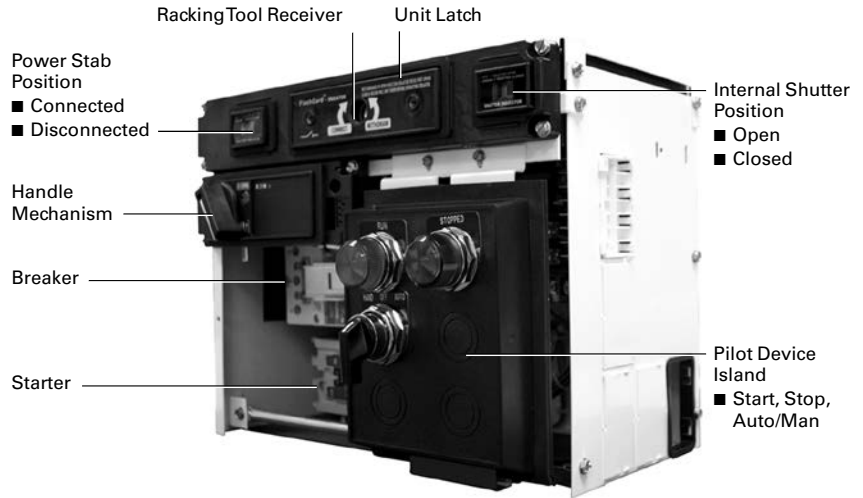

Freedom FlashGard FVNR Starter

The Freedom FlashGard units are equipped with a “retractable stab” mechanism called RotoTract, that allows the electrical worker to connect and disconnect power to the bucket with the **unit door closed**, thereby minimizing exposure to arc flash. A visual indication is provided on the unit door on the “Connected” and “Disconnected” positions of RotoTract. A visual indication on the position of the shutters that enclose the stabs is also provided (open shutters indicate that stabs are extended and closed shutters indicate that the stabs are withdrawn). A motorized tool such as an electric screwdriver, drill with a 3/8-inch square drill bit or standard 3/8-inch drive ratchet is used to operate RotoTract through its racking tool receiver.

Additional safety features of a FlashGard unit include:

- **Unit Latch**—When the RotoTract is in “Connected” position, this latch is mechanically interlocked to hook the bucket to the divider pan that separates the bucket from the unit above, thereby preventing physical removal of the bucket when it is connected to 480V and/or control power. The unit latch also prevents insertion of a bucket with the stabs extended
- **RotoTract racking tool receiver shutter**—When the breaker is in the “On” position, the shutter for the access hole in the RotoTract (access hole is needed for the motorized tool to retract the stabs) is closed, thereby not allowing the stabs to be retracted when the breaker is energized

Freedom FlashGard starters are equipped with electromechanical starters and contactors NEMA size 1–5.

Freedom FlashGuard Stab Assembly

Stabs Extended



Stabs Withdrawn



Freedom FlashGuard Plug-in Unit Bus Stabs

The Freedom FlashGuard MCC uses a “retractable stab” mechanism, called RotoTract, that allows the electrician to connect and disconnect power to the bucket with the unit door closed. A visual indication is provided on the unit door on the “Connected” and “Disconnected” positions of RotoTract. A visual indication on the position of the shutters that enclose the stabs is also provided (open shutters indicate that stabs are extended and closed shutters indicate that the stabs are withdrawn). A motorized tool or standard 3/8-inch (9.5 mm) drive ratchet is used to operate RotoTract’s “retractable stab” mechanism. A wired remote racking accessory is also available for operating RotoTract with a pendant station safely beyond the NFPA-prescribed flash protection boundaries.

The stabs are constructed from a tin-plated copper alloy, incorporating the ultimate in mechanical simplicity to provide precise control of contact pressure on the bus. This ensures a positive connection, yet permits easy unit insertion and withdrawal. The stabs are self-aligning and are mounted in a glass-reinforced plastic insulation block, which totally shrouds each stab and ensures positive alignment of the stabs with the vertical bus. The insulation block is also an integral part of the phase-phase isolation system. Power wiring is welded to the stabs and is totally contained within the unit enclosure. The wire is designed for a high level of flexibility to be suitable for RotoTract’s retractable stab mechanism.

Stab assemblies are accurately matched to the electrical requirements of each individual unit and are provided in 60 A, 150 A, 300 A or 400 A ratings (plug-in through Size 5).

Freedom FlashGuard Handle Mechanism



Circuit Breaker Handle Mechanism

The handle mechanism is designed to provide a high mechanical leverage, so that little effort is required to operate any device.

The standard handle mechanism is a vertical motion type device with four positions: ON, OFF, TRIPPED and RESET. Only circuit breaker types have tripped and reset positions. It is securely mounted to the front of the unit and mechanically connected to the breaker or fusible switch, eliminating alignment problems. It provides a positive indication of the breaker or switch position, even with the door open.

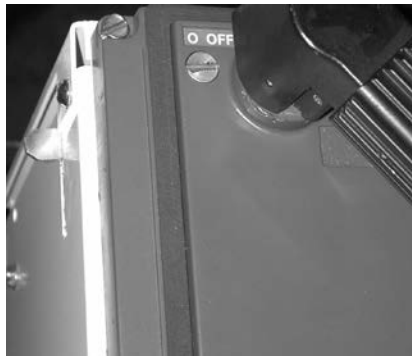

Unit Insertion Interlock

The handle and exterior front panel are molded from the same plastic material as the device panel. A textured surface preserves the appearance. The ON position indicator is at the top and is a bright red. The OFF/RESET position is at the bottom and is bright green.



Padlocking Bar

The handle mechanism for Freedom FlashGuard provides several safety features:

- In the ON position, an interlock prevents the unit door from being opened. A door interlock defeater screw located to the right of the handle is provided to enable authorized maintenance personnel access to the units when required
- The unit insertion interlock is located to the left of the operating handle. The interlock must be in the locked position in order to turn the disconnect on. When the interlock is in the locked position, the unit cannot be withdrawn or inserted
- To ensure that units are not energized accidentally or by unauthorized personnel, the handle mechanism can be padlocked in the OFF position. Sufficient space is available for a maximum of three padlocks. Where critical processes are involved and to prevent unauthorized shutdown, the handle mechanism can be modified to enable padlocking in the ON position

Each unit has a safe lock position. This interlock will lock the unit in a position off the 480 V bus and ensure the unit cannot be inserted or withdrawn.



Freedom FlashGuard Unit Wrapper Side Latch

Freedom FlashGard Unit Wrapper

The unit wrapper is fabricated of 14-gauge steel. After fabrication, it is cleaned and given a rust inhibiting phosphating treatment. The finish on a unit wrapper is a baked Munsell No. N9.43/0.21B, 0.23 white. This is highly durable finish, gloss-white in color to increase visibility within the unit and to facilitate wiring and maintenance procedures.

The unit wrapper consists of a three-sided rugged steel shell including the mounting base for the unit components. The smallest unit measures 13-3/4 inches (349.3 mm) wide, 8.00 inches (203.2 mm) deep and 6.00 inches (152.4 mm) high. Units increase in 6.00-inch (152.4 mm) increments to a maximum height of 72.00 inches (1828.8 mm).

The unit wrapper is designed to provide ample space for cable entry from the wireway to the unit.

The unit wrapper has four mounting points, two on each side, which support the unit in the structure. They engage guide rails located near the top of each unit space. This mounting point guide rail system produces minimum friction and allows units to be inserted and withdrawn easily. The guide rails also give precise alignment to the unit for accurate stabbing on the vertical bus.



Freedom FlashGard Plug-in Unit Wrapper

FlashGard Padlock Accessory



FlashGard Padlock Accessory

- Locks out RotoTract operation during maintenance
- Allows operation of FlashGard units by authorized personnel only
- Provided as standard on NEMA 12 FlashGard MCCs (prevents dust entry into RotoTract access port)
- Heavy-gauge steel construction

FlashGard Remote Racking Accessory



Remote Racking Accessory

- Performs RotoTract racking safely behind NFPA Arc Flash boundaries
- 120 Vac motor driven
- Mounts to RotoTract mechanism
- Wired pendant station for “rack-in”/“rack-out” operation
- Momentary jog
- Mounting offset bracket to clear device panel

Voltage Presence Indicator (VoltageVision™)

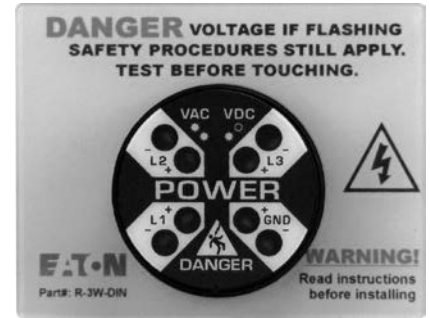

Voltage Presence Indicator (VoltageVision)

- Hardwired voltage detector connected to load side of disconnect
- Enables operator to “pre-verify” voltage presence with unit door closed
- Installable in a 30 mm pilot device knockout
- Dual redundant circuitry for reliability
- Phase insensitive

Panduit® Absence of Voltage Testers (AVTs)

- VeriSafe AVTs can be added as an engineered option
- Enables end users to improve lockout/tagout procedures
 - Ex. Ensuring isolation at motors enables de-energization at line side of mains (high incident energy areas)
- Installable in a 30 mm pilot device knockout
- Application expertise for a variety of locations in MCCs



Panduit Absence of Voltage Tester

Unit Maintenance

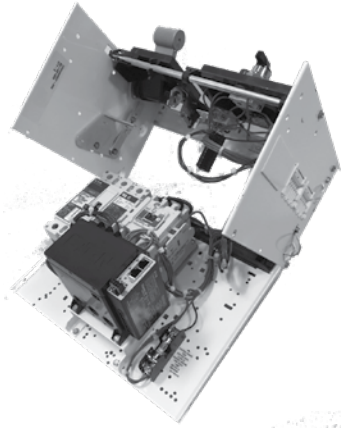

Plug-in Unit Maintenance

The Freedom three-piece (clam shell) unit wrapper design facilitates easy work bench maintenance. When removed from the MCC, the unit top/side barrier assembly can easily be swiveled up and back for complete access to components and wiring.

Terminal Blocks

A side-mounted, seven-circuit, latching pull-apart terminal block is standard on units with NEMA Type B or C wiring. This industrial-grade Eaton MCC terminal block provides solid electrical connections while conserving space and making installation and maintenance easier.

Terminal blocks are mounted in knockouts on the vertical wireway side of the unit housing affording greater access to the unit compartment and interior components. The two-piece terminal block snap-locks together to ensure permanent circuit continuity. To aid installation and wiring checks, the terminal marking strips for both sides of the terminal block are fully visible from the front of the starter compartment.



Side Mounted—Latched Pull-Apart Terminal Block

Heavy-duty saddle wire terminals are of the resilient collar design, which eliminates loose connections caused by expansion and contracting of the conductor as the current is switched on and off. This unique design maintains constant pressure as the wire expands and contracts. This 600 V, 30 A rated terminal block will accept 12 awg stripped wires, as well as 14 AWG ring or spade wire lugs. All terminal block conductors are fully shielded for added safety and cleanliness.

A 12.00-inch (304.8 mm) high (2X space) starter unit accommodates up to three side-mounted terminal blocks providing a maximum of 21 points. Larger units accommodate two additional 7-point terminal blocks for every additional 6.00 inches (152.4 mm) 1X space of unit height. The 6.00-inch (152.4 mm) compact starter unit uses a 9-point pull-apart terminal block, which is installed along the top front of the starter unit.



Side-Mounted Terminal Blocks

Control wiring within each starter compartment consists of 16 awg control wire for Freedom FlashGard MCCs and 2100 Series MCCs. Rated 105 °C, the flame-retardant, thermoplastic insulated wire is red. Power wiring is black and sized to carry the maximum full load current of the starter unit.

Front-Rail-Mounted Terminal Blocks

For special applications, other types of rail-mounted terminal blocks are also available. They are installed horizontally at the bottom front of the starter unit. Refer to Eaton for terminal block types available and space restrictions.

Devices

Unit Doors

Unit doors are formed of 14-gauge steel with a 0.50-inch (12.7 mm) flange on all four sides. The flange adds rigidity to the door and provides a surface to contain door gasketing. Cutouts are made in the door as required to accommodate the operating handle and device panel. The doors are cleaned, phosphatized and given a finish of gray, baked-on enamel ANSI 61 (Munsell No. N9.43/0.21B, 0.23).

The doors will open 115° opposite to the wireway doors permitting optimum access to the unit compartment. The doors are mounted on removable concealed pin hinges. This permits quick removal of any door in a vertical structure without disturbing adjacent doors.

Doors 2X and larger are held closed with a minimum of two quarter-turn indicating-type fasteners. They securely hold the door in the closed position, yet allow quick and easy access to the unit when required. The fasteners provide a visual indication of the latched position. The head slot of the fastener is designed to prevent screwdriver slippage.



Freedom 12.00-Inch (304.8 mm) Unit Door



Freedom FlashGard 12.00-Inch (304.8 mm) Unit Door



Spring-Loaded Unit Door Quarter-Turn Latch

Solid-State Motor Protection



C440/XT Electronic Overload Relay

Eaton's C400 series solid-state overload relay offers improved motor protection due to high repeat accuracy and fast reaction times to phase failures. The state-of-the-art microelectronics design permits the choice of relays with different trip classes (Class 5, 10, 20, 30) to accommodate motors with a variety of application needs.

The C440 solid-state overloads are available on all Freedom starter sizes. (Size 5 and up use CTs with the overload relay.) Key features include:

- Phase loss
- Phase imbalance
- Wide adjustment range
- Low energy usage
- Reduced heat

With the simple addition of a communication module, the C440 is capable of communicating to one of the following industrial field buses: DeviceNet, Modbus RTU, PROFIBUS, EtherNet/IP or ModbusTCP.



C441 Overload Relays

The C441 Motor Insight® is a microprocessor-based solid-state overload relay providing superior motor protection, communications and motor monitoring features. This overload provides the standard set of protections that includes I²t, jam, stall and phase protections. The C441 also provides ground fault, phase reversal, voltage unbalance, programmable trip class, trip history, thermal capacity, power factor and voltage, current and power monitoring. With the simple addition of a communication module, the C441 is capable of communicating to one of the following industrial field busses: DeviceNet, Modbus RTU, PROFIBUS, EtherNet/IP or Modbus TCP.

Key features of C441 Motor Insight communicating overloads include:

- DeviceNet, Modbus, PROFIBUS and Ethernet communication options
- Three-phase voltage monitoring
- Three-phase current monitoring
- kWh usage indication
- Motor power factor indication
- Last four faults history
- Optional remote mounted display
- I/O communication adapter with four inputs and two outputs
- Programmable set points, including:
 - Low-voltage set point
 - High-voltage set point
 - Voltage unbalance set point
 - CT multiplier/ratio settings
 - Overcurrent set point
 - Current unbalance trip point
 - Trip Class (5, 10, 15, 20, 30, and/or Jam)
 - Rapid cycle timer
 - Restart delay timer
 - Underload restart delay timer
 - Number of restarts after faults (Manual/Auto)
 - Undercurrent trip delay
 - Ground fault trip set point



C445 Motor Management Relays

The Power Xpert C445 motor management relay provides the highest level of monitoring accuracy and protection for the entire power system—from the incoming power source feeding the motor to the individual pump or load. With the built-in user-defined logic and ground fault detection/monitoring, the C445 provides customers with the highest level of motor protection and versatility while maximizing uptime.

Key features of C445 Motor Management Relays include:

- 0.3–800 A current range
- 690 Vac, 4160 Vac with potential transformers (PTs)
- 20–80 Hz operation
- Selectable trip class (5–40)
- 120/240 Vac or 24 Vdc control power options
- On-board I/O
 - 4 digital inputs: 120 Vac or 24 Vdc
 - 3 relay outputs: 2NO, 1NO/NC
- Optional external expansion I/O
 - Digital I/O 64 in and 64 out
 - Up to 8 analog I/O cards (RTD and thermocouple input cards)
- Logic engine allows for programming local logic with function block programming
- On-board communication options:
 - EtherNet/IP
 - Modbus® TCP
 - Modbus RTU
 - Web pages
 - PROFIBUS®
 - USB
- Real-time clock (RTC), backup non-volatile memory and positive temperature coefficient (PTC) options
- Flexible user interface options
- Power Xpert inControl configuration and monitoring software tool
- Ground fault detection
 - Residual
 - Pulse detection
 - Zero sequencing
 - High resistance ground
- Reliability
 - Advanced diagnostics allow for quick and accurate identification of the root cause of a fault in line, load and motor conditions
 - Voltage loss restart functionality allows for automatic recovery in the event of undervoltage conditions without the need for user intervention
 - Pre-programmed operation modes support fast, easy, error-free installation for the majority of applications
- Flexibility
 - Modular pass-through design with scalable options for current, voltage, power, energy protections and monitoring
 - Fully programmable trip and alarm thresholds and time delays

Motor Protection

In line with 2005 NEC 430.6(A) circuit breaker, HMCP and fuse rating selections are based on full load currents for induction motors running at speeds normal for belted motors and motors with normal torque characteristics using data taken from NECTable 130.250 (three-phase). Actual motor nameplate ratings shall be used for selecting motor running overload protection. Motors built special for low speeds, high torque characteristics, special starting conditions and applications will require other considerations as defined in the application section of the NEC.

These additional considerations may require the use of a higher rated HMCP, or at least one with higher magnetic pickup settings.

Circuit breaker, HMCP and fuse ampere rating selections are in line with maximum rules given in NEC 430.52 and Table 430.250. Based on known characteristics of Eaton type breakers, specific units are recommended. The current ratings are no more than the maximum limits set by the NEC rules for motors with code letters F to V or without code letters. Motors with lower code letters will require further considerations.

In general, these selections were based on:

1. Ambient—Outside enclosure not more than 40 °C (104 °F).
2. Motor starting—Infrequent starting, stopping or reversing.
3. Motor accelerating time—10 seconds or less.
4. Locked rotor—Maximum 6 times motor FLA.

Type HMCP motor circuit protector may not set at more than 1300% of the motor full-load current to comply with NEC 430.52. (Except for NEMA Design B energy high-efficiency motors which can be set up to 1700%.)

Circuit breaker selections are based on types with standard interrupting ratings. Higher interrupting rating types may be required to satisfy specific system application requirements.

For motor full load currents of 208 and 200 volts, increase the corresponding 230-volt motor values by 10 and 15% respectively.

Table 29.1-23. Motor Circuit Protector (MCP), Circuit Breaker and Fusible Switch Selection Guide

Horsepower	Full Load Amperes (NEC) FLA	Fuse Size NEC 430.52 Maximum Amperes		Circuit Breaker			
		Time Delay	Non-Time Delay	Circuit Breaker		Motor Circuit Protector Type HMCP	
				Amperes	Type	Amperes	Adj. Range
230 Volts, Three-Phase							
1	3.6	10	15	15	HFD	7	21-70
1-1/2	5.2	10	20	15	HFD	15	45-150
2	6.8	15	25	15	HFD	15	45-150
3	9.6	20	30	20	HFD	30	90-300
5	15.2	30	50	30	HFD	30	90-300
7-1/2	22	40	70	50	HFD	50	150-500
10	28	50	90	60	HFD	50	150-500
15	42	80	150	90	HFD	100	300-1000
20	54	100	175	100	HFD	100	300-1000
25	68	125	225	125	HFD	150	450-1500
30	80	150	250	150	HFD	150	450-1500
40	104	200	350	150	HFD	150	750-2500
50	130	250	400	200	HFD	150	750-2500
60	154	300	500	225	HFD	250	1250-2500
75	192	350	600	300	HKD	400	2000-4000
100	248	450	800	400	HKD	400	2000-4000
125	312	600	1000	500	HLD	600	1800-6000
150	360	700	1200	600	HLD	600	1800-6000
200	480	1000	1600	700	HND	600	1800-6000
460 Volts, Three-Phase							
1	1.8	6	6	15	HFD	7	21-70
1-1/2	2.6	6	10	15	HFD	7	21-70
2	3.4	6	15	15	HFD	7	21-70
3	4.8	10	15	15	HFD	15	45-150
15	7.6	15	25	15	HFD	15	45-150
7-1/2	11	20	35	25	HFD	30	90-300
10	14	25	45	35	HFD	30	90-300
15	21	40	70	45	HFD	50	150-500
20	27	50	90	50	HFD	50	150-500
25	34	60	110	70	HFD	70	210-700
30	40	70	125	70	HFD	100	300-1000
40	52	100	175	100	HFD	100	300-1000
50	65	125	200	110	HFD	150	450-1500
60	77	150	150	125	HFD	150	750-2500
75	96	175	300	150	HJD	150	750-2500
100	124	225	400	175	HJD	150	750-2500
125	156	300	500	225	HKD	400	2000-4000
150	180	350	600	250	HJD	400	2000-4000
200	240	450	800	350	L600	600	1800-6000
575 Volts, Three-Phase							
1	1.4	3	6	15	HFD	3	9-30
1-1/2	2.1	6	10	15	HFD	7	21-70
2	2.7	6	10	15	HFD	7	21-70
3	3.9	10	15	15	HFD	7	21-70
15	6.1	15	20	15	HFD	15	45-150
7-1/2	9	20	30	20	HFD	30	90-300
10	11	20	35	25	HFD	30	90-300
15	17	30	60	40	HFD	30	90-300
20	22	40	70	50	HFD	50	150-500
25	27	50	90	60	HFD	50	150-500
30	32	60	100	60	HFD	70	210-500
40	41	80	125	80	HFD	100	300-1000
50	52	100	175	100	HFD	100	300-1000
60	62	110	200	125	HFD	150	750-2500
75	77	150	250	150	HFD	150	750-2500
100	99	175	300	175	HJD	150	750-2500
125	125	225	400	200	HJD	250	1250-2500
150	144	300	450	225	HJD	250	1250-2500
200	192	350	600	300	HKD	400	2000-4000

Table 29.1-24. Short-Circuit Ratings for Motor Control

Unit Type		Unit Size	Unit Short-Circuit Rating (kA)											
			240 V				480 V				600 V			
			HMCP	MCCB	High-Interrupting MCCB	Fusible Switch	HMCP	MCCB	High-Interrupting MCCB	Fusible Switch	HMCP	MCCB	High-Interrupting MCCB	Fusible Switch
Freedom combination starters	FVNR FVR 2S1W 2S2W RVAT	1	100	65	100	100	100	65	100	100	25 ①	25 ①	35	100
		2	100	65	100	100	100	65	100	100	25 ①	25 ①	35	100
		3	100	65	100	100	100	65	100	100	25 ①	25 ①	35	100
		4	100	65	100	100	100	65	100	100	25 ①	25 ①	35	100
		5	100	65	100	100	100	65	100	100	25	25 ②	50	100
		6	65	65	65	65	65 ③	65 ④	65 ④	65	—	—	—	—
		7	65	65	65	—	65	65	65	—	—	—	—	—
	RVPW RVYD	1	100	65	100	100	100	65	100	100	25 ①	25 ①	35	100
		2	100	65	100	100	100	65	100	100	25 ①	25 ①	35	100
		3	100	65	100	100	100	65	100	100	25 ①	25 ①	35	100
		4	100	65	100	100	100	65	100	100	25	25	50	100
		5	100	65	100	100	100	65	100	100	—	35	—	100
		6	65	65	65	65	65 ③	65 ④	65 ④	65	—	—	—	—
		7	65	65	65	—	65	65	65	—	—	—	—	—
	Vacuum starters	4	—	—	—	—	65 ①	65	100	100	25 ①	25	—	100
		5	—	—	—	—	100	65	100	100	18	25	35	100
		6	—	—	—	—	65	65	—	100	25	35	—	100
	S811+ soft starters	65MM	100	100	—	—	100	65	—	100	10	10	—	100
		110MM	100	100	—	—	100	65	—	100	10	10	—	100
		200MM	100	100	—	—	100	65	—	100	18	18	—	100
		290MM	100	100	—	—	100 ⑤	65	—	100	35 ③	35 ③	—	100
Variable frequency drives	DG1	FR0	100	100	100	100	65	65	100	100	—	—	—	—
		FR1	100	100	100	100	65	65	100	100	—	—	—	—
		FR2	100	100	100	100	65	65	100	100	—	—	—	—
		FR3	100	100	100	100	65	65	100	100	—	—	—	—
		FR4	100	100	100	100	65	65	100	100	—	—	—	—
		FR5	100	100	100	100	65	65	100	100	—	—	—	—
		FR6	—	—	—	100	65	65	65	100	—	—	—	—
	SVX9000	FR4	100	100	100	100	65	65	100	100	—	—	—	—
		FR5	100	100	100	100	65	65	100	100	—	—	—	—
		FR6	100	100	100	100	65	65	100	100	—	—	—	—
		FR7	100	100	100	100	65	65	100	100	—	—	—	—
		FR8	100	100	100	100	65	65	100	100	—	—	—	—
		FR9	65	100	200	100	65	65	100	100	—	—	—	—
		FR10	—	—	—	100	65	65	100	100	—	—	—	—
		FR11	—	—	—	100	65	65	100	100	—	—	—	—
		CPX	—	—	—	—	65	65	100	100	—	—	—	—

① 100 kA is available with the addition of a current limiter attachment.

② 50 kA is available with 400 A LGH breaker.

③ 42 kA is available with 1200 A frame HMCP or RGH.

④ Only rated 42 kA with 1200 A disconnect.

⑤ Only rated 65 kA above 420 A.

Table 29.1-25. Combination Starters with Motor Circuit Protectors or Molded Case Breakers—Dimensions in Inches (mm)

Motor circuit protector ratings are suitable for both NEMA Design B and NEMA Design E (high efficiency) motors. Per NEC, the motor circuit protectors may be adjusted to 17X motor FLA.

NEMA Size	Maximum Horsepower					HMCP Frame	MCCB Frame	Standard Unit Size	
	208V	240V	380V	480V	600V			Inches (mm)	X Space
Full Voltage Non-Reversing (F206)									
1	7.5	7.5	10	10	10	125	EG	6.00 (152.4) ①	1X ①
	7.5	7.5	10	10	10	150	HFD/FDC	12.00 (304.8) ①	2X ①
2	10	15	25	25	25	125	EG	6.00 (152.4) ①	1X ①
	10	15	25	25	25	150	HFD/FDC	12.00 (304.8) ①	2X ①
3	25	30	50	50	50	125	EG	12.00 (304.8) ①	2X ①
	25	30	50	50	50	150	HFD/FDC	18.00 (457.2) ①	3X ①
4	40	50	75	100	100	250	JG	12.00 (304.8) ①	2X ①
	40	50	75	100	100	150	—	24.00 (609.6) ①	4X ①
	40	50	75	100	100	—	HJD/JDC	30.00 (762.0) ①	5X ①
5	50	60	100	125	150	250	HJD/JDC	36.00 (914.4) ①	6X ①
	75	100	150	200	200	400	HKD/KDC	36.00 (914.4) ①	6X ①
6	150	200	300	400	—	600	HLD/LDC	48.00 (1219.2)	8X
7	200	300	—	600	—	1200	NG	72.00 (1828.8) ②	12X ②
Full Voltage Reversing (F216)									
1	7.5	7.5	10	10	10	125	EG	12.00 (304.8) ①	2X ①
	7.5	7.5	10	10	10	150	HFD/FDC	18.00 (457.2) ①	3X ①
2	10	15	25	25	25	125	EG	12.00 (304.8) ①	2X ①
	10	15	25	25	25	150	HFD/FDC	18.00 (457.2) ①	3X ①
3	25	30	50	50	50	125	EG	18.00 (457.2) ①	3X ①
	25	30	50	50	50	150	HFD/FDC	24.00 (609.6) ①	4X ①
4	40	50	75	100	100	250	JG	18.00 (457.2) ①	3X ①
	40	50	75	100	100	250	HJD/JDC	30.00 (762.0) ①	5X ①
5	50	60	100	125	150	250	HJD/JDC	60.00 (1524.0) ①	10X ①
	75	100	150	200	200	400	HKD/KDC	60.00 (1524.0) ①	10X ①
6	150	200	300	400	—	600	HLD/LDC	54.00 (1371.6) ②	9X ②
Two-Speed One Winding (F946)									
1	7.5	7.5	10	10	10	150	HFD/FDC	24.00 (609.6) ①	4X ①
2	10	15	25	25	25	150	HFD/FDC	24.00 (609.6) ①	4X ①
3	25	30	50	50	50	150	HFD/FDC	36.00 (914.4) ①	6X ①
4	40	50	75	100	100	250	HJD/JDC	54.00 (1371.6) ①	9X ①
5	50	60	100	125	150	250	HJD/JDC	72.00 (1828.8) ②	12X ②
	75	100	150	200	200	400	HKD/KDC	72.00 (1828.8) ②	12X ②
Two-Speed Two Winding (F956)									
1	7.5	7.5	10	10	10	150	HFD/FDC	24.00 (609.6) ①	4X ①
2	10	15	25	25	25	150	HFD/FDC	24.00 (609.6) ①	4X ①
3	25	30	50	50	50	150	HFD/FDC	36.00 (914.4) ①	6X ①
4	40	50	75	100	100	250	HJD/JDC	54.00 (1371.6) ①	9X ①
5	50	60	100	125	150	250	HJD/JDC	72.00 (1828.8) ②	12X ②
	75	100	150	200	200	400	HKD/KDC	72.00 (1828.8) ②	12X ②
Reduced Voltage Autotransformer (F606)									
2	10	15	25	25	25	150	HFD/FDC	36.00 (914.4) ①	6X ①
3	25	30	50	50	50	150	HFD/FDC	48.00 (1219.2) ①	8X ①
4	30	50	75	100	100	250	HJD/JDC	60.00 (1524.0) ①	10X ①
5	50	60	100	125	150	250	HJD/JDC	72.00 (1828.8) ③	12X ③
	75	100	150	200	200	400	HKD/KDC	72.00 (1828.8) ③	12X ③
6	150	200	300	400	400	600	HLD/LDC	72.00 (1828.8) ②	12X ②

① For FlashGard units, add 6.00-inch (152.4 mm) / 1X.

② Requires 28.00-inch (711.2 mm) wide structure.

③ Requires 24.00-inch (609.6 mm) wide structure.

Table 29.1-25. Combination Starters with Motor Circuit Protectors or Molded Case Breakers—Dimensions in Inches (mm) (Continued)

Motor circuit protector ratings are suitable for both NEMA Design B and NEMA Design E (high efficiency) motors. Per NEC, the motor circuit protectors may be adjusted to 17X motor FLA.

NEMA Size	Maximum Horsepower					HMCP Frame	MCCB Frame	Standard Unit Size	
	208V	240V	380V	480V	600V			Inches (mm)	X Space
Reduced Voltage Part Winding (F706)									
1	7.5	7.5	10	10	10	150	HFD/FDC	24.00 (609.6) ①	4X ①
2	10	15	25	25	25	150	HFD/FDC	24.00 (609.6) ①	4X ①
3	25	30	50	50	50	150	HFD/FDC	30.00 (762.0) ①	5X ①
4	—	—	—	100	125	150	HFD/FDC	54.00 (1371.6) ①	9X ①
	60	60	125	150	150	250	HJD/JDC	72.00 (1828.8) ①	12X ①
	75	75	150	—	—	400	HKD/KDC	72.00 (1828.8) ①	12X ①
5	100	125	—	250	300	400	HKD/KDC	72.00 (1828.8) ②	12X ②
	150	150	250	350	350	600	HLD/LDC	72.00 (1828.8) ②	12X ②
Reduced Voltage Wye Delta Open Transition (F806)									
2	20	25	40	40	40	150	HFD/FDC	30.00 (762.0) ①	5X ①
3	30	40	75	75	75	150	HFD/FDC	42.00 (1066.8) ①	7X ①
	40	50	—	—	—	250	HJD/JDC	42.00 (1066.8) ①	7X ①
4	60	75	125	150	150	250	HJD/JDC	60.00 (1524.0) ①	10X ①
	—	—	150	—	—	400	HKD/KDC	60.00 (1524.0) ①	10X ①
5	100	125	200	250	300	400	HKD/KDC	72.00 (1828.8) ②	12X ②
	150	150	250	300	—	600	HLD/LDC	72.00 (1828.8) ②	12X ②
Reduced Voltage Wye Delta Closed Transition (F896)									
2	20	25	40	40	40	150	HFD/FDC	42.00 (1066.8) ①	7X ①
3	30	40	75	75	75	150	HFD/FDC	54.00 (1371.6) ①	9X ①
	40	50	—	—	—	250	HJD/JDC	54.00 (1371.6) ①	9X ①
4	60	75	125	150	150	250	HJD/JDC	72.00 (1828.8)	12X
	—	—	150	—	—	400	HKD/KDC	72.00 (1828.8)	12X
5	100	125	200	250	300	400	HKD/KDC	72.00 (1828.8) ②	12X ②
	150	150	250	300	—	600	HLD/LDC	72.00 (1828.8) ②	12X ②

① For FlashGard units, add 6.00-inch (152.4 mm) / 1X.

② Requires 28.00-inch (711.2 mm) wide structure.

Table 29.1-26. Combination Starters with Fusible Switches—Dimensions in Inches (mm) ①

All of Eaton’s combination starters are available with Class R or J fuse clips for all voltages. If 100 kA SCR is required at 575 V and 600 V, fuses must be used where current limiting options are not available in combination with breakers. When selecting fuse switches, the fuses are not supplied by default. Fuses may be selected as follows:

- RK5: 1.25x FLC
- RK1: 1.3x FLC
- Class J: 1.5x FLC

NEMA Size	Maximum Horsepower					Switch Rating	Standard Unit Size	
	208V	240V	380V	480V	600V		Inches (mm)	X Space
Full Voltage Non—Reversing (F204)								
1	7.5	7.5	10	10	10	30	12.00 (304.8) ②	2X ②
2	10	15	25	25	25	60	12.00 (304.8) ②	2X ②
3	25	30	50	50	50	60/100	24.00 (609.6) ②	4X ②
4	40	50	75	100	100	100/200	36.00 (914.4) ②	6X ②
5	75	100	150	200	200	400	60.00 (1524.0) ②	10X ②
6	150	200	300	400	400	600	72.00 (1828.8) ③	12X ③
Full Voltage Reversing (F214)								
1	7.5	7.5	10	10	10	30	12.00 (304.8) ②	4X ②
2	10	15	25	25	25	60	12.00 (304.8) ②	4X ②
3	25	30	50	50	50	60/100	18.00 (457.2) ②	5X ②
4	40	50	75	100	100	100/200	18.00 (457.2) ②	10X ②
5	75	100	150	200	200	400	60.00 (1524.0) ②	12X ②
6	150	200	300	400	400	600	72.00 (1828.8) ④	12X ④
Two—Speed One Winding (F944)								
1	7.5	7.5	10	10	10	30	24.00 (609.6) ②	4X ②
2	10	15	25	25	25	60	24.00 (609.6) ②	4X ②
3	25	30	—	30	50	60	36.00 (914.4) ②	6X ②
	25	30	50	50	50	100	36.00 (914.4) ②	6X ②
4	—	—	—	—	60	100	60.00 (1524.0) ②	10X ②
	40	50	75	100	100	200	60.00 (1524.0) ②	10X ②
5	75	100	150	200	200	400	72.00 (1828.8) ⑤	12X ⑤
Two—Speed Two Winding (F954)								
1	7.5	7.5	10	10	10	30	24.00 (609.6) ②	4X ②
2	10	15	25	25	25	60	24.00 (609.6) ②	4X ②
3	—	—	—	—	30	60	30.00 (762.0) ②	5X ②
	25	30	50	50	50	100	30.00 (762.0) ②	5X ②
4	—	—	—	—	60	100	54.00 (1371.6) ②	9X ②
	40	50	75	100	100	200	54.00 (1371.6) ②	9X ②
5	75	100	150	200	200	400	72.00 (1828.8) ⑤	12X ⑤
Reduced Voltage Autotransformer (F604)								
2	10	15	25	25	25	60	36.00 (914.4) ②	6X ②
3	25	30	50	50	50	100	54.00 (1371.6) ②	9X ②
4	40	50	75	100	100	200	72.00 (1828.8)	12X
5	75	100	150	200	200	400	72.00 (1828.8) ⑤	12X ⑤
6	150	200	300	400	400	600	72.00 (1828.8) ⑤	12X ⑤
Reduced Voltage Part Winding (F704)								
1	10	10	15	15	15	60	24.00 (609.6) ②	4X ②
2	—	15	25	30	40	60	24.00 (609.6) ②	4X ②
	20	25	40	40	—	100	24.00 (609.6) ②	4X ②
3	—	—	—	50	60	100	48.00 (1219.2) ②	8X ②
	40	50	75	75	75	200	48.00 (1219.2) ②	8X ②
4	50	—	100	100	150	200	72.00 (1828.8)	12X
	75	75	150	150	—	400	72.00 (1828.8)	12X
5	100	100	200	250	300	400	72.00 (1828.8) ⑤	12X ⑤
	150	150	250	350	350	600	72.00 (1828.8) ⑤	12X ⑤

① Not available in Freedom Arc-Resistant.

② For FlashGard units, add 6.00-inch (152.4 mm) / 1X.

③ For top exit, 32.00-inch (812.8 mm) wide structure required.

④ For bottom exit, 28.00-inch (711.2 mm) wide structure required. For top exit, 36.00-inch (914.4 mm) wide structure required.

⑤ Requires 28.00-inch (711.2 mm) wide structure.

Table 29.1-26. Combination Starters with Fusible Switches—Dimensions in Inches (mm) ① (Continued)

NEMA Size	Maximum Horsepower					Switch Rating	Standard Unit Size	
	208V	240V	380V	480V	600V		Inches (mm)	X Space
Reduced Voltage Wye Delta Open Transition (F804)								
2	15	15	30	40	40	60	30.00 (762.0) ②	5X ②
	20	25	40	—	—	100	30.00 (762.0) ②	5X ②
3	25	30	50	60	75	100	48.00 (1219.2) ②	8X ②
	40	50	75	75	—	200	48.00 (1219.2) ②	8X ②
4	50	60	100	125	150	200	72.00 (1828.8)	12X
	60	75	150	150	—	400	72.00 (1828.8)	12X
5	100	125	200	250	300	400	72.00 (1828.8)	12X
	150	150	250	300	—	600	72.00 (1828.8)	12X
6	—	—	—	—	350	400	72.00 (1828.8) ③	12X ③
	—	200	350	400	500	600	72.00 (1828.8) ③	12X ③
	250	250	400	500	700	800	72.00 (1828.8) ③	12X ③
	300	350	500	700	700	1200	72.00 (1828.8) ③	12X ③
	—	—	—	—	—	—	—	—
Reduced Voltage Wye Delta Closed Transition (F894)								
2	15	15	30	40	40	60	30.00 (762.0) ②	5X ②
	20	25	40	—	—	100	30.00 (762.0) ②	5X ②
3	25	30	50	60	75	100	66.00 (1676.4) ②	11X ②
	40	50	75	75	—	200	66.00 (1676.4) ②	11X ②
4	50	60	100	125	150	200	72.00 (1828.8) ③	12X ③
	60	75	150	150	—	400	72.00 (1828.8) ③	12X ③
5	100	125	200	250	300	400	72.00 (1828.8) ③	12X ③
	150	150	250	300	—	600	72.00 (1828.8) ③	12X ③
6	—	—	—	—	350	400	72.00 (1828.8) ③	12X ③
	—	200	350	400	500	600	72.00 (1828.8) ③	12X ③
	250	250	400	500	700	800	72.00 (1828.8) ③	12X ③
	300	350	500	700	700	1200	72.00 (1828.8) ③	12X ③
	—	—	—	—	—	—	—	—

① Not available in Freedom Arc Resistant.

② For FlashGard units, add 6.00-inch (152.4 mm) / 1X.

③ Requires 28.00-inch (711.2 mm) wide structure.

Solid-State Reduced Voltage Starters (SSRV)



S811+ SSRV

S811+ Solid-State Reduced Voltage (SSRV) starters are designed to reduce the inrush current to a motor during starting and to limit the amount of available starting torque, thus reducing mechanical wear and utility demand requirements. The amount of starting current is field adjustable to match the specific requirements of all applications.

Eaton’s S811+ SSRV controllers are available with a wide variety of standard features: kick start, soft stop, phase loss and stall protection. S811+ SSRV starters are 30–70% smaller than competitive designs and contain an integral fully rated bypass relay that almost eliminates heat generation when the motor is at speed.

Typical applications include conveyors, compressors, machine tools, pumps and fans.

S811+ Solid-State Reduced Voltage Starter

Eaton’s S811+ solid-state reduced voltage starter uses SCRs when starting and a low impedance run circuit during operation. The S811+ solid-state starter has five 24Vdc inputs and two relay outputs. S811+ soft start units include a disconnect, starter, 24 Vdc power supply and 100 VA CPT.

Motor Service Factor (SF) Effect on S811+ Starter Selection

- A 1.0 service factor motor may draw up to 1.00 x full load amperes
- A 1.15 service factor motor may draw up to 1.15 x full load amperes (15% more current). This chart is based off of a 1.15 SF motor selection
- S811+ starters are current rated devices. In some cases, a larger S811+ SSRV starter must be supplied for 1.15 SF motors. See Table 29.1-27 for maximum horsepower.

Table 29.1-27. S811+ Reduced Voltage Soft Starters with Motor Circuit Protectors or Molded Case Breakers—Dimensions in Inches (mm)

Frame Size	Current Rating (A)	Maximum Horsepower ①②					Standard Unit Size ③	
		208V	240V	380V	480V	600V	Inches (mm)	X Space
Standard Duty								
N (65 mm)	37	10	10	15	20	30	18.00 (457.2) ④	3X ④
	66	15	20	30	40	50	18.00 (457.2) ④	3X ④
R (110 mm)	105	30	30	45	60	75	18.00 (457.2) ④	3X ④
	135	40	40	55	75	100	24.00 (609.6) ④	4X ④
T (200 mm)	180	50	60	75	125	150	36.00 (914.4) ④	6X ④
	240	60	75	110	150	200	36.00 (914.4) ④	6X ④
	304	75	100	132	200	250	36.00 (914.4) ④	6X ④
V (290 mm)	360	100	125	160	250	300	54.00 (1371.6) ④	9X ④
	420	125	—	200	300	350	54.00 (1371.6) ④	9X ④
	500	—	150	250	350	450	54.00 (1371.6) ④	9X ④
	650	200	200	315	450	600	72.00 (1828.8)	12X
	720	—	250	—	500	—	72.00 (1828.8)	12X
	850	—	300	375	600	700	72.00 (1828.8)	12X
	1000	—	350	500	700	900	72.00 (1828.8) ⑤	12X ⑤
	Severe Duty							
N (65 mm)	22	5	5	7.5	10	15	18.00 (457.2) ④	3X ④
	42	10	10	18.5	25	30	18.00 (457.2) ④	3X ④
R (110 mm)	65	15	20	22	40	50	18.00 (457.2) ④	3X ④
	80	20	25	37	50	60	18.00 (457.2) ④	3X ④
T (200 mm)	115	30	30	55	75	100	36.00 (914.4) ④	6X ④
	150	40	50	—	100	125	36.00 (914.4) ④	6X ④
	192	50	60	90	125	150	36.00 (914.4) ④	6X ④
V (290 mm)	240	60	—	110	150	—	54.00 (1371.6) ④	9X ④
	305	75	100	132	200	250	54.00 (1371.6) ④	9X ④
	365	100	125	160	250	300	72.00 (1828.8)	12X
	420	125	—	200	300	350	72.00 (1828.8)	12X
	480	—	150	220	350	450	72.00 (1828.8)	12X

① Maximum hp values assume a service factor of 1.15.
 ② 380V values are listed in kW, not hp.
 ③ Unit sizing may vary, based on configured options. Consult factory.
 ④ For FlashGard units, add 6.00-inch (152.4 mm) / 1X.
 ⑤ Requires 28.00-inch (711.2 mm) wide structure.

Table 29.1-28. S811+ Reduced Voltage Soft Starters with Fusible Switch—Dimensions in Inches (mm) ①

Frame Size	Current Rating (A)	Maximum Horsepower ②③					Standard Unit Size ④	
		208V	240V	380V	480V	600V	Inches (mm)	X Space
Standard Duty								
N (65 mm)	37	10	10	15	20	30	18.00 (457.2) ⑤	3X ⑥
	66	15	20	30	40	50	18.00 (457.2) ⑤	3X ⑥
R (110 mm)	105	30	30	45	60	75	30.00 (762.0) ⑤	5X ⑥
	135	40	40	55	75	100	30.00 (762.0) ⑤	5X ⑥
T (200 mm)	180	50	60	75	125	150	60.00 (1524.0) ⑤	10X ⑥
	240	60	75	110	150	200	60.00 (1524.0) ⑤	10X ⑥
	304	75	100	132	200	250	60.00 (1524.0) ⑤	10X ⑥
V (290 mm)	360	100	125	160	250	300	72.00 (1828.8)	12X
	420	125	—	200	300	350	72.00 (1828.8)	12X
	500	—	150	250	350	450	72.00 (1828.8)	12X
	650	200	200	315	450	600	72.00 (1828.8) ⑥	12X ⑥
	720	—	250	—	500	—	72.00 (1828.8) ⑥	12X ⑥
	850	—	300	375	600	700	72.00 (1828.8) ⑥	12X ⑥
	1000	—	350	500	700	900	72.00 (1828.8) ⑥	12X ⑥
Severe Duty								
N (65 mm)	22	5	5	7.5	10	15	18.00 (457.2) ⑤	3X ⑥
	42	10	10	18.5	25	30	18.00 (457.2) ⑤	3X ⑥
R (110 mm)	65	15	20	22	40	50	30.00 (762.0) ⑤	5X ⑥
	80	20	25	37	50	60	30.00 (762.0) ⑤	5X ⑥
T (200 mm)	115	30	30	55	75	100	60.00 (1524.0) ⑤	10X ⑥
	150	40	50	—	100	125	60.00 (1524.0) ⑤	10X ⑥
	192	50	60	90	125	150	60.00 (1524.0) ⑤	10X ⑥
V (290 mm)	240	60	—	110	150	—	72.00 (1828.8)	12X
	305	75	100	132	200	250	72.00 (1828.8)	12X
	365	100	125	160	250	300	72.00 (1828.8)	12X
	420	125	—	200	300	350	72.00 (1828.8)	12X
	480	—	150	220	350	450	72.00 (1828.8)	12X

- ① Not available in Freedom Arc-Resistant.
- ② Maximum hp values assume a service factor of 1.15.
- ③ 380V values are listed in kW, not hp.
- ④ Unit sizing may vary, based on configured options. Consult factory.
- ⑤ For FlashGard units, add 6.00-inch (152.4 mm) / 1X.
- ⑥ Requires 36.00-inch (914.4 mm) wide structure.

Table 29.1-29. Control Options

Extra 50 VA Control Power Transformer ⑦
24Vdc Control ⑦
Line or Load MOV Protection ⑦
Pump Control Option ⑦

⑦ Option fits in standard unit space.

Table 29.1-30. Option Sizing for Isolating Contactor and Bypass Starter ⑧

S811+ Width (mm)	Fused Switch Type (Amperes)	Starter Size	Option Unit Size Inches (mm)	FlashGard Unit Size Inches (mm)	Structure Width Inches (mm)
65	30/60/100	1, 2, 3	36.00 (914.4)	36.00 (914.4)	20.00 (508.0)
110	100	3	42.00 (1066.8)	42.00 (1066.8)	20.00 (508.0)
110	200	4	54.00 (1371.6)	54.00 (1371.6)	20.00 (508.0)
200	400/800	5, 6	72.00 (1828.8)	72.00 (1828.8)	32.00 (812.8)
290	600/800	6	72.00 (1828.8)	72.00 (1828.8)	36.00 (914.4)
290	800/1200	7	72.00 (1828.8)	72.00 (1828.8)	64.00 (1625.6)

⑧ Not available in Freedom Arc-Resistant.

Table 29.1-31. FLA Ratings

Ramp Current % of FLA	Ramp Time	Starts Per Hour	Similar to Starting Method
Standard Duty			
300%	30 seconds	3	Soft start
500%	10 seconds	3	Full voltage
350%	20 seconds	3	Wye delta
480%	20 seconds	2	80% RVAT
390%	20 seconds	3	65% RVAT
300%	20 seconds	4	50% RVAT
Severe Duty			
450%	30 seconds	4	Soft start
500%	10 seconds	10	Full voltage
350%	65 seconds	3	Wye delta
480%	25 seconds	4	80% RVAT
390%	40 seconds	4	65% RVAT
300%	60 seconds	4	50% RVAT

Adjustable Frequency Drives

Adjustable Frequency Drives are available for control of standard AC motors in processes that benefit from the ability to change motor speed. Use of Inverter Duty motors is recommended.

Controllers are available to handle constant torque applications, such as conveyors and crushers, and variable torque applications, such as fans and pumps. Control schemes are available for volts/Hz, open loop vector and closed loop vector models. All drive structures are bus connected, which allows for expansion of the MCC on both sides of the structure. A wide range of AFD features and options are available to meet the requirements of most applications including IEEE 519 compliant applications. AFDs are available in NEMA 1A gasketed enclosures. AFDs are available in NEMA 3R MCC enclosures from 1 to 200 hp, constant torque.

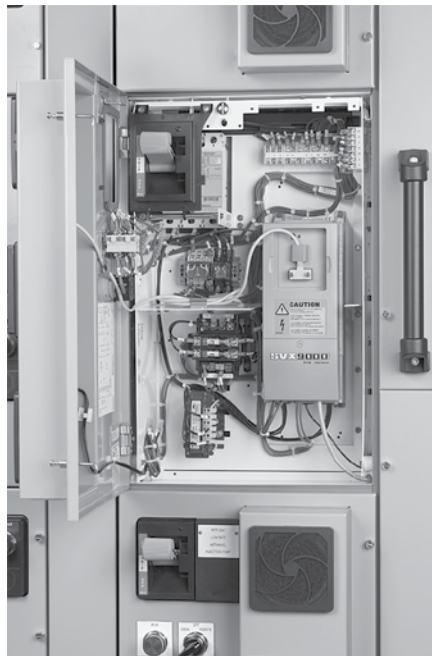

SVX9000 Adjustable Frequency Drive

SVX9000 drive units are available in MCCs for loads up to 600 hp. Units include, as standard: integral 3% line reactor, 3% output reactor and door-mounted keypad. Available options include: Dv/Dt filter, line fuses, line and/or isolation contactors, 3-contactor bypass and more. Refer to **Table 29.1-32** thru **Table 29.1-38** for more information.

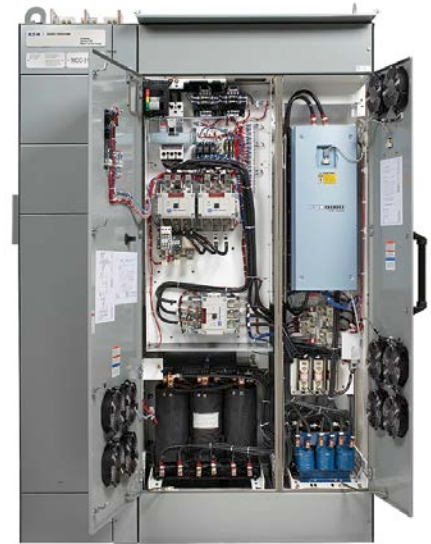

CPX9000 Adjustable Frequency Drive

CPX9000 drive units are available in MCCs for loads up to 500 hp. Units are 18-pulse and meet IEEE 519 requirements without the need for additional filtering. Refer to **Table 29.1-39** and **Table 29.1-40** for more information.



DG1 Adjustable Frequency Drive

DG1 drive units are available in MCCs for loads up to 250 hp. Units include, as standard: 5% DC link choke, 3% output reactor and door-mounted keypad. Available options include: Dv/Dt filter, line fuses, line and/or isolation contactors, 3-contactor bypass and more. Refer to **Table 29.1-32** thru **Table 29.1-38** for more information.

Table 29.1-32. SVX9000 Adjustable Frequency Drives with Motor Circuit Protectors or Molded Case Breakers—Dimensions in Inches (mm)

Frame Size	Current Rating (A)	Maximum hp		Standard Unit Size ①	
		VT	CT	Inches (mm)	X Space
208–240V					
FR4	3.7	1	0.75	18.00 (457.2) ②	3X ③
	4.8	v1.5	1	18.00 (457.2) ②	3X ③
	6.6	2	1.5	18.00 (457.2) ②	3X ③
	7.8	3	2	18.00 (457.2) ②	3X ③
	11	—	3	18.00 (457.2) ②	3X ③
FR5	12.5	5	—	24.00 (609.6) ②	4X ④
	17.5	7.5	5	24.00 (609.6) ②	4X ④
	25	10	7.5	24.00 (609.6) ②	4X ④
FR6	31	15	10	42.00 (1066.8) ②	7X ⑤
	48	20	15	42.00 (1066.8) ②	7X ⑤
FR7	61	25	20	54.00 (1371.6) ②	9X ⑥
	75	30	25	54.00 (1371.6) ②	9X ⑥
	88	40	30	54.00 (1371.6) ②	9X ⑥
FR8	114	50	40	72.00 (1828.8)	12X
	140	60	50	72.00 (1828.8)	12X
	170	75	60	72.00 (1828.8)	12X
FR9	205	100	75	72.00 (1828.8) ③	12X ③
	261	125	100	72.00 (1828.8) ③	12X ③

380–500V

FR4	2.2	—	1	18.00 (457.2) ②	3X ③
	3.3	1.5	1.5	18.00 (457.2) ②	3X ③
	4.3	2	2	18.00 (457.2) ②	3X ③
	5.6	3	3	18.00 (457.2) ②	3X ③
	7.6	5	5	18.00 (457.2) ②	3X ③
12	7.5	—	18.00 (457.2) ②	3X ③	
FR5	12	—	7.5	24.00 (609.6) ②	4X ④
	16	10	10	24.00 (609.6) ②	4X ④
	23	15	15	24.00 (609.6) ②	4X ④
	31	20	—	24.00 (609.6) ②	4X ④
FR6	31	—	20	42.00 (1066.8) ②	7X ⑤
	38	25	25	42.00 (1066.8) ②	7X ⑤
	46	30	30	42.00 (1066.8) ②	7X ⑤
	61	40	—	42.00 (1066.8) ②	7X ⑤
FR7	61	—	40	54.00 (1371.6) ②	9X ⑥
	72	50	50	54.00 (1371.6) ②	9X ⑥
	87	60	60	54.00 (1371.6) ②	9X ⑥
	105	75	—	54.00 (1371.6) ②	9X ⑥
FR8	105	—	75	72.00 (1828.8)	12X
	140	100	100	72.00 (1828.8)	12X
	170	125	125	72.00 (1828.8)	12X
	205	150	—	72.00 (1828.8)	12X
FR9	205	—	150	72.00 (1828.8) ③	12X ③
	245	—	200	72.00 (1828.8) ③	12X ③
	261	200	—	72.00 (1828.8) ③	12X ③
FR10	330	250	250	72.00 (1828.8) ④	12X ④
	385	300	300	72.00 (1828.8) ④	12X ④
	460	350	350	72.00 (1828.8) ④	12X ④
	520	400	—	72.00 (1828.8) ④	12X ④

① Unit sizing may vary, based on configured options. Consult factory.

② For FlashGard units, add 6.00-inch (152.4 mm) / 1X.

③ Requires 28.00-inch (711.2 mm) wide structure.

④ Requires 64.00-inch (1625.6 mm) wide structure.

Table 29.1-33. DG1 Adjustable Frequency Drives with Motor Circuit Protectors or Molded Case Breakers—Dimensions in Inches (mm)

Frame Size	Current Rating (A)	Maximum hp		Standard Unit Size ⑤	
		VT	CT	Inches (mm)	X Space
208–240V					
FR0/FR1	3.7	—	0.75	18.00 (457.2) ⑥	3X ③
	4.8	1	1	18.00 (457.2) ⑥	3X ③
	6.6	1.5	1.5	18.00 (457.2) ⑥	3X ③
FR1	7.8	2	2	18.00 (457.2) ⑥	3X ③
	11	3	3	18.00 (457.2) ⑥	3X ③
FR2	17.5	5	5	24.00 (609.6) ⑥	4X ④
	25	7.5	7.5	24.00 (609.6) ⑥	4X ④
	31	10	—	24.00 (609.6) ⑥	4X ④
FR3	31	—	10	36.00 (914.4) ⑥	6X ⑥
	48	15	15	36.00 (914.4) ⑥	6X ⑥
	61	20	—	36.00 (914.4) ⑥	6X ⑥
FR4	61	—	20	54.00 (1371.6) ⑥	9X ⑥
	75	25	25	54.00 (1371.6) ⑥	9X ⑥
	88	30	30	54.00 (1371.6) ⑥	9X ⑥
	114	40	—	54.00 (1371.6) ⑥	9X ⑥
FR5	114	—	40	72.00 (1828.8)	12X
	143	50	50	72.00 (1828.8)	12X
	170	60	60	72.00 (1828.8)	12X
	211	75	—	72.00 (1828.8)	12X

380–500V

FR0/FR1	2.2	—	1	18.00 (457.2) ⑥	3X ③
	3.3	1.5	1.5	18.00 (457.2) ⑥	3X ③
	4.3	2	2	18.00 (457.2) ⑥	3X ③
	5.6	3	3	18.00 (457.2) ⑥	3X ③
	7.6	5	—	18.00 (457.2) ⑥	3X ③
FR1	12	7.5	—	18.00 (457.2) ⑥	3X ③
FR2	12	—	7.5	24.00 (609.6) ⑥	4X ④
	16	10	10	24.00 (609.6) ⑥	4X ④
	23	15	15	24.00 (609.6) ⑥	4X ④
	31	20	—	24.00 (609.6) ⑥	4X ④
FR3	31	—	20	36.00 (914.4) ⑥	6X ⑥
	38	25	25	36.00 (914.4) ⑥	6X ⑥
	46	30	30	36.00 (914.4) ⑥	6X ⑥
	61	40	—	36.00 (914.4) ⑥	6X ⑥
FR4	61	—	40	54.00 (1371.6) ⑥	9X ⑥
	72	50	50	54.00 (1371.6) ⑥	9X ⑥
	87	60	60	54.00 (1371.6) ⑥	9X ⑥
	105	75	—	54.00 (1371.6) ⑥	9X ⑥
FR5	105	—	75	72.00 (1828.8)	12X
	140	100	100	72.00 (1828.8)	12X
	170	125	125	72.00 (1828.8)	12X
	205	150	—	72.00 (1828.8)	12X
FR6	205	—	150	72.00 (1828.8) ⑦	12X ⑦
	245	—	200	72.00 (1828.8) ⑦	12X ⑦
	261	200	—	72.00 (1828.8) ⑦	12X ⑦
	310	250	—	72.00 (1828.8) ⑦	12X ⑦

⑤ Unit sizing may vary, based on configured options. Consult factory.

⑥ For FlashGard units, add 6.00-inch (152.4 mm) / 1X.

⑦ Requires 28.00-inch (711.2 mm) wide structure.

Table 29.1-34. SVX9000 Adjustable Frequency Drives with Fusible Switch—Dimensions in inches (mm) ①

Frame Size	Current Rating (A)	Maximum hp		Standard Unit Size ②	
		VT	CT	Inches (mm)	X Space
208–240 V					
FR4	3.7	1	0.75	30.00 (762.0) ③	5X ③
	4.8	1.5	1	30.00 (762.0) ③	5X ③
	6.6	2	1.5	30.00 (762.0) ③	5X ③
	7.8	3	2	30.00 (762.0) ③	5X ③
	11	—	3	30.00 (762.0) ③	5X ③
FR5	12.5	5	—	36.00 (914.4) ③	6X ③
	17.5	7.5	5	36.00 (914.4) ③	6X ③
	25	10	7.5	36.00 (914.4) ③	6X ③
FR6	31	15	10	48.00 (1219.2) ③	8X ③
	48	20	15	48.00 (1219.2) ③	8X ③
FR7	61	25	20	72.00 (1828.8)	12X
	75	30	25	72.00 (1828.8)	12X
	88	40	30	72.00 (1828.8)	12X
FR8	114	50	40	72.00 (1828.8) ④	12X ④
	140	60	50	72.00 (1828.8) ④	12X ④
	170	75	60	72.00 (1828.8) ④	12X ④
FR9	205	100	75	72.00 (1828.8) ⑤	12X ⑤
	261	125	100	72.00 (1828.8) ⑤	12X ⑤
380–500 V					
FR4	2.2	—	1	30.00 (762.0) ③	5X ③
	3.3	1.5	1.5	30.00 (762.0) ③	5X ③
	4.3	2	2	30.00 (762.0) ③	5X ③
	5.6	3	3	30.00 (762.0) ③	5X ③
	7.6	5	5	30.00 (762.0) ③	5X ③
	12	7.5	—	30.00 (762.0) ③	5X ③
FR5	12	—	7.5	36.00 (914.4) ③	6X ③
	16	10	10	36.00 (914.4) ③	6X ③
	23	15	15	36.00 (914.4) ③	6X ③
	31	20	—	36.00 (914.4) ③	6X ③
FR6	31	—	20	48.00 (1219.2) ③	8X ③
	38	25	25	48.00 (1219.2) ③	8X ③
	46	30	30	48.00 (1219.2) ③	8X ③
	61	40	—	48.00 (1219.2) ③	8X ③
FR7	61	—	40	72.00 (1828.8)	12X
	72	50	50	72.00 (1828.8)	12X
	87	60	60	72.00 (1828.8)	12X
	105	75	—	72.00 (1828.8)	12X
FR8	105	—	75	72.00 (1828.8) ④	12X ④
	140	100	100	72.00 (1828.8) ④	12X ④
	170	125	125	72.00 (1828.8) ④	12X ④
	205	150	—	72.00 (1828.8) ④	12X ④
FR9	205	—	150	72.00 (1828.8) ⑤	12X ⑤
	245	—	200	72.00 (1828.8) ⑤	12X ⑤
	261	200	—	72.00 (1828.8) ⑤	12X ⑤
FR10	330	250	250	72.00 (1828.8) ⑥	12X ⑥
	385	300	300	72.00 (1828.8) ⑥	12X ⑥
	460	350	350	72.00 (1828.8) ⑥	12X ⑥
	520	400	—	72.00 (1828.8) ⑥	12X ⑥

① Not available in Freedom Arc-Resistant.
 ② Unit sizing may vary, based on configured options. Consult factory.
 ③ For FlashGard units, add 6.00-inch (152.4 mm) / 1X.
 ④ Requires 32.00-inch (812.8 mm) wide structure.
 ⑤ Requires 40.00-inch (1016.0 mm) wide structure.
 ⑥ Requires 80.00-inch (2032.0 mm) wide structure.

Table 29.1-35. DG1 Adjustable Frequency Drives with Fusible Switch—Dimensions in Inches (mm) ⑦

Frame Size	Current Rating (A)	Maximum hp		Standard Unit Size ⑧	
		VT	CT	Inches (mm)	X Space
208–240 V					
FR0/FR1	3.7	—	0.75	30.00 (762.0) ⑨	5X ⑨
	4.8	1	1	30.00 (762.0) ⑨	5X ⑨
	6.6	1.5	1.5	30.00 (762.0) ⑨	5X ⑨
FR1	7.8	2	2	30.00 (762.0) ⑨	5X ⑨
	11	3	3	30.00 (762.0) ⑨	5X ⑨
FR2	17.5	5	5	36.00 (914.4) ⑨	6X ⑨
	25	7.5	7.5	36.00 (914.4) ⑨	6X ⑨
	31	10	—	36.00 (914.4) ⑨	6X ⑨
FR3	31	—	10	48.00 (1219.2) ⑨	8X ⑨
	48	15	15	48.00 (1219.2) ⑨	8X ⑨
	61	20	—	48.00 (1219.2) ⑨	8X ⑨
FR4	61	—	20	72.00 (1828.8)	12X
	75	25	25	72.00 (1828.8)	12X
	88	30	30	72.00 (1828.8)	12X
	114	40	—	72.00 (1828.8)	12X
FR5	114	—	40	72.00 (1828.8) ⑩	12X ⑩
	143	50	50	72.00 (1828.8) ⑩	12X ⑩
	170	60	60	72.00 (1828.8) ⑩	12X ⑩
	211	75	—	72.00 (1828.8) ⑩	12X ⑩

⑦ Not available in Freedom Arc-Resistant.
 ⑧ Unit sizing may vary, based on configured options. Consult factory.
 ⑨ For FlashGard units, add 6.00-inch (152.4 mm) / 1X.
 ⑩ Requires 32.00-inch (812.8 mm) wide structure.
 ⑪ Requires 40.00-inch (1016.0 mm) wide structure.

Table 29.1-36. Adjustable Frequency Drives Passive Filters Addition

Horsepower (Maximum)	SVX Drive (Amperes)	Passive Input (Amperes)	Height	Unit Space (X)
1	2.2	6	36.0 (914.4)	6X
1.5	3.3	6	36.0 (914.4)	6X
3	5.6	6	36.0 (914.4)	6X
5	7.6	8	36.0 (914.4)	6X
7.5	12	14	36.0 (914.4)	6X
10	16	21	36.0 (914.4)	6X
15	23	27	36.0 (914.4)	6X
20	31	34	36.0 (914.4)	6X
25	38	44	36.0 (914.4)	6X
30	46	52	48.0 (1219.2)	8X
40	61	66	48.0 (1219.2)	8X
50	72	83	48.0 (1219.2)	8X
60	87	103	48.0 (1219.2)	8X
75	105	128	60.0 (1524.0)	10X
100	140	165	60.0 (1524.0)	10X
125	170	208	60.0 (1524.0)	10X
150	205	208	60.0 (1524.0)	10X
200 ①	261	320	72.0 (1828.8)	12X

① Not available in Freedom Arc-Resistant.

Note: Passive filters are a separate unit located next to the connected AFD. Passive filters can reduce THD of the connected AFD to 8% or less. Passive filters are not interlocked to the AFD compartment.

Table 29.1-37. SVX9000 and DG1 Adjustable Frequency Drives in NEMA 3R MCCs—Dimensions in Inches (mm) ②

I _H Amperes	Nominal hp I _H ③	I _L Amperes	Nominal hp I _L	CB Type ④		Unit Space (Typ./Max)	
				HMCP	MCCB	Dim.	(X)
380–500 V							
2.2	1.0	3.3	1.5	7	15	30.00 (762.0)	5X
3.3	1.5	4.3	2.0	7	15	30.00 (762.0)	5X
4.3	2.0	5.6	3.0	7	15	30.00 (762.0)	5X
5.6	3.0	7.6	5.0	15	15	30.00 (762.0)	5X
7.6	5.0	12.0	7.5	15	15	30.00 (762.0)	5X
12.0	7.5	16.0	10.0	30	25	72.00 (1828.8)	12X
16.0	10.0	23.0	15.0	30	35	72.00 (1828.8)	12X
23.0	15.0	31.0	20.0	30	50	72.00 (1828.8)	12X
31.0	20.0	38.0	25.0	50	60	72.00 (1828.8)	12X
38.0	25.0	46.0	30.0	50	80	72.00 (1828.8)	12X
46.0	30.0	61.0	40.0	100	100	72.00 (1828.8)	12X

② This table is common for both Freedom and Freedom FlashGard MCC.

③ A separate CPT bucket is provided for all AFDs (1–5 hp) listed in the table.

④ For fusible disconnect, use typical option unit.

Note: Drive units fit into a standard 20.00-inch (508.0 mm) wide structure.

Table 29.1-38. Options

Plug-in Options	
Option Boards ⑤	
I/O Expander	⑥
Encoder Expander	⑥
Interbus S Communications	⑥
Modbus Communications	⑥
PROFIBUS DP Communications	⑥
LonWorks Communications	⑥
Can Open (Slave) Communications	⑥
DeviceNet Communications	⑦
Johnson Controls N2 Communications	⑥
PROFIBUS DP (D9 Connector)	⑥
EtherNet/IP Communications	⑥
ModbusTCP Communications	⑥
Modbus (D9 Connector)	⑥
Plug-in Control Relays	
One relay	⑧
Two relays	⑧
Three relays	⑨
Other Options	
Automatic bypass circuit	⑩
Bypass drive test switch	⑩
Seven relay 120V control with CPT	⑧
Isolated signal processor	⑥
3–15 PSIG interface	⑥
Dynamic breaking resistors	⑪
Graphics keypad	⑦
Line fuses	⑥⑧
RFI filter	⑦
Deduct to remove output filter	⑪
V1K 2000 ft (610m) Dv/Dt filter	⑨
Output contactor	⑥
Dual overloads	⑥⑨
Three contactor bypass	⑥⑨

⑤ Up to five option boards may be selected.

⑥ All options will fit in typical and maximum option unit.

⑦ This option will fit in all units.

⑧ One of these options will fit in 5–30 hp CT at 480 V frame standard units, 1–30 hp CT at 480 V typical and maximum option units.

⑨ All options will fit in maximum option unit.

⑩ Use with bypass option.

⑪ DB resistors are to be mounted by the customer external to the MCC.

Note: Output reactor or Dv/Dt filter not required for motor lead lengths shorter than 100 feet (30.4 m)—30 feet (9.1 m) for 2 hp and below).

Note: Maximum motor lead length is 160 feet (48.8 m) for 1.5 hp and below, 330 feet (100.6 m) for 2 hp and 400 feet (121.9 m) for 3 hp and larger when using a standard output reactor.

Note: Motor lead lengths up to 2000 feet (609.6 m) can be achieved by using a Dv/Dt filter.

CPX9000 Clean Power Drives 1–500 hp at 480 V

Eaton’s CPX9000 Clean Power Drives use advanced 18-pulse, clean-power technology that significantly reduces line harmonics at the drive input terminals, resulting in one of the purest sinusoidal waveforms.

I_H (CT): High overload drives are capable of producing 200% starting torque for 10 seconds and are rated 150% overload for one minute. Essentially a constant torque drive.

I_L (VT): Low overload drives are capable of producing 200% starting torque for 10 seconds and are rated 110% overload for one minute. Essentially a variable torque drive.

Table 29.1-39. CPX9000 Low Overload Clean Power Drives, Thermal-Magnetic Breaker and Motor Circuit Protector (MCP) Disconnect ①
—Dimensions in Inches (mm)

Low Overload Drive ②		High Overload Drive ②		CB Type ③		Standard Unit Space Dimensions Inches (mm) ④			
I _L Amperes	Nominal hp I _L	I _H Amperes	Nominal hp I _H	HMCP	MCCB	Width	Height	Depth	X Space
38	25 ⑤	31	20 ⑤	50	80	40.00 (1016.0)	90.00 (2286.0)	21.00 (533.4)	12X
46	30 ⑤	38	25 ⑤	100	100	40.00 (1016.0)	90.00 (2286.0)	21.00 (533.4)	12X
61	40 ⑤	46	30 ⑤	100	125	40.00 (1016.0)	90.00 (2286.0)	21.00 (533.4)	12X
72	50 ⑤	61	40 ⑤	100	150	40.00 (1016.0)	90.00 (2286.0)	21.00 (533.4)	12X
87	60 ⑤	72	50 ⑤	100	175	40.00 (1016.0)	90.00 (2286.0)	21.00 (533.4)	12X
105	75 ⑤	87	60 ⑤	150	225	40.00 (1016.0)	90.00 (2286.0)	21.00 (533.4)	12X
140	100 ⑤	105	75 ⑤	150	300	40.00 (1016.0)	90.00 (2286.0)	21.00 (533.4)	12X
170	125 ⑤	140	100 ⑤	250	400	40.00 (1016.0)	90.00 (2286.0)	21.00 (533.4)	12X
205	150 ⑤	170	125 ⑤	400	400	40.00 (1016.0)	90.00 (2286.0)	21.00 (533.4)	12X
261	200	205	150	600	600	60.00 (1524.0)	90.00 (2286.0)	21.00 (533.4)	12X
330	250	261	200	600	600	60.00 (1524.0)	90.00 (2286.0)	21.00 (533.4)	12X
385	300 ⑥	330	250 ⑥	600	600	68.00 (1727.2)	90.00 (2286.0)	28.00 (711.2)	12X
460	350 ⑥	385	300 ⑥	600	600	68.00 (1727.2)	90.00 (2286.0)	28.00 (711.2)	12X
520	400 ⑥	460	350 ⑥	600	600	68.00 (1727.2)	90.00 (2286.0)	28.00 (711.2)	12X
590	500 ⑥	520	400 ⑥	1200	1200	106.00 (2692.4)	90.00 (2286.0)	28.00 (711.2)	12X

① Not available in Freedom Arc-Resistant.

② The CPX9000 drive uses the term Low Overload (I_L) in place of the term “Variable Torque” and High Overload (I_H) in place of the term “Constant Torque.”

③ CPX9000 Drives in MCCs are available in thermal-magnetic breaker, motor circuit protector and fused disconnect configurations.

④ A minimum clearance of 4.00 inches (101.6 mm) should be provided at the back of CPX9000 Drive MCC section for ventilation.

⑤ Add 32.00 inches (812.8 mm) of width for bypass.

⑥ Required transformer section is 28.00 (711.2) deep. CPX and bypass is 21.00 (533.4) deep.

Table 29.1-40. CPX9000 Low Overload Clean Power Drives, Fusible Switch Disconnect—Dimensions in Inches (mm) ⑦

Low Overload Drive ⑧		High Overload Drive ⑧		Fuse Switch		Standard Unit Space Dimensions Inches (mm) ④			
I _L Amperes	Nominal hp I _L	I _H Amperes	Nominal hp I _H	Fuse	Switch	Width	Height	Depth	X Space
38	25 ⑨	31	20 ⑨	50	60	40.00 (1016.0)	90.00 (2286.0)	21.00 (533.4)	12X
46	30 ⑨	38	25 ⑨	60	60	40.00 (1016.0)	90.00 (2286.0)	21.00 (533.4)	12X
61	40 ⑨	46	30 ⑨	80	100	40.00 (1016.0)	90.00 (2286.0)	21.00 (533.4)	12X
72	50 ⑨	61	40 ⑨	100	100	40.00 (1016.0)	90.00 (2286.0)	21.00 (533.4)	12X
87	60 ⑨	72	50 ⑨	100	100	40.00 (1016.0)	90.00 (2286.0)	21.00 (533.4)	12X
105	75 ⑨	87	60 ⑨	100	100	40.00 (1016.0)	90.00 (2286.0)	21.00 (533.4)	12X
140	100 ⑨	105	75 ⑨	175	200	40.00 (1016.0)	90.00 (2286.0)	21.00 (533.4)	12X
170	125 ⑨	140	100 ⑨	200	200	40.00 (1016.0)	90.00 (2286.0)	21.00 (533.4)	12X
205	150 ⑨	170	125 ⑨	250	400	40.00 (1016.0)	90.00 (2286.0)	21.00 (533.4)	12X
261	200	205	150	350	600	60.00 (1524.0)	90.00 (2286.0)	21.00 (533.4)	12X
330	250	261	200	450	600	60.00 (1524.0)	90.00 (2286.0)	21.00 (533.4)	12X
385	300 ⑩	330	250 ⑩	600	600	68.00 (1727.2)	90.00 (2286.0)	28.00 (711.2)	12X
460	350 ⑩	385	300 ⑩	600	600	68.00 (1727.2)	90.00 (2286.0)	28.00 (711.2)	12X
520	400 ⑩	460	350 ⑩	600	600	68.00 (1727.2)	90.00 (2286.0)	28.00 (711.2)	12X
590	500 ⑩	520	400 ⑩	800	1200	106.00 (2692.4)	90.00 (2286.0)	28.00 (711.2)	12X

⑦ Not available in Freedom Arc-Resistant.

⑧ The CPX9000 product uses the term Low Overload (I_L) in place of the term “Variable Torque” and High Overload (I_H) in place of the term “Constant Torque.”

④ A minimum clearance of 4.00 inches (101.6 mm) should be provided at the back of CPX9000 Drive MCC section for ventilation.

⑨ Add 32.00 inches (812.8 mm) of width for bypass.

⑩ Required transformer section is 28.00 (711.2) deep. CPX and bypass is 21.00 (533.4) deep.

Harmonic Correction Units

Clean Control Center with Active Harmonic Control— Typical Layout

The layout to the right is a typical arrangement for Eaton’s Clean Control Center including harmonic correction units for nonlinear loads such as AC Variable Frequency Drives. The horizontal bus of the Clean Control Center is virtually free of harmonic current content at the point where the harmonic correction unit connects to the bus. From this point to the connection at the utility bus, the Clean Control Center complies with the most stringent requirements of IEEE 519 and provides a clean waveform to the upstream distribution system. Harmonic correction may be applied to loads fed directly from the MCC (e.g., MCC mounted AC drives) or loads fed indirectly from the MCC (e.g., MCC mounted circuit breakers feeding remote drives). Multiple correction units may be used to achieve the level of harmonic correction as required by the amount of nonlinear loads within the MCC lineup.

Harmonic Correction

The Clean Control Center uses a harmonic correction unit to provide harmonic cancellation directly on the motor control center horizontal bus. The harmonic correction unit senses the load current and injects into the AC lines a synthesized waveform that is inverted compared to the remaining signal. The result is a clean waveform as seen by the upstream electrical system. Single or multiple harmonic correction units may be applied within a Clean Control Center providing an economical solution to excessive harmonics due to AC drives or other nonlinear loads. Use of the Clean Control Center will provide compliance to the most stringent 5% Total Demand Distortion (TDD) requirements of IEEE 519. Clean Control Center assemblies include a 24.00-inch (609.6 mm) wide MCC structure, active harmonic correction unit, current transformers and a door-mounted digital interface panel.

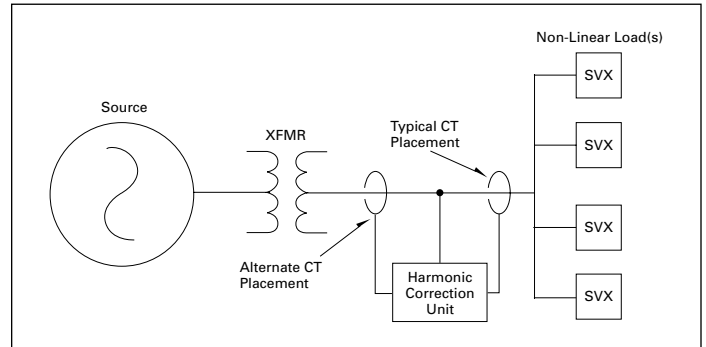

Figure 29.1-3. Clean Control Center Installation Diagram

Table 29.1-41. Clean Control Center ①

Eaton’s Clean Control Center is an integrated power correction system that provides harmonic correction directly on the MCC horizontal bus. The harmonic correction unit senses the load current and dynamically injects into the horizontal bus a synthesized waveform that cancels harmonic content from nonlinear loads such as AC drives. The result is a clean waveform. Clean Control Centers are UL 845 listed.

Harmonic Current (Amperes)	Input Voltage	Disconnect Type	Standard Unit Space ② Inches (mm)	Standard Unit Space (X)
50 A active harmonic filter ③	Up to 480 V	Molded case switch	72.00 H x 20.00 W (1828.8 H x 508.0 W)	12X
100 A active harmonic filter ③	Up to 480 V	Molded case switch	72.00 H x 20.00 W (1828.8 H x 508.0 W)	12X

- ① This table is common for Freedom, Freedom Arc-Resistant and Freedom FlashGard MCCs.
- ② Clean Control Center model includes 24.00-inch (609.6 mm) wide MCE structure, current transformers and door-mounted digital interface panel.
- ③ Multiple units can be applied in parallel for additional harmonic correction.

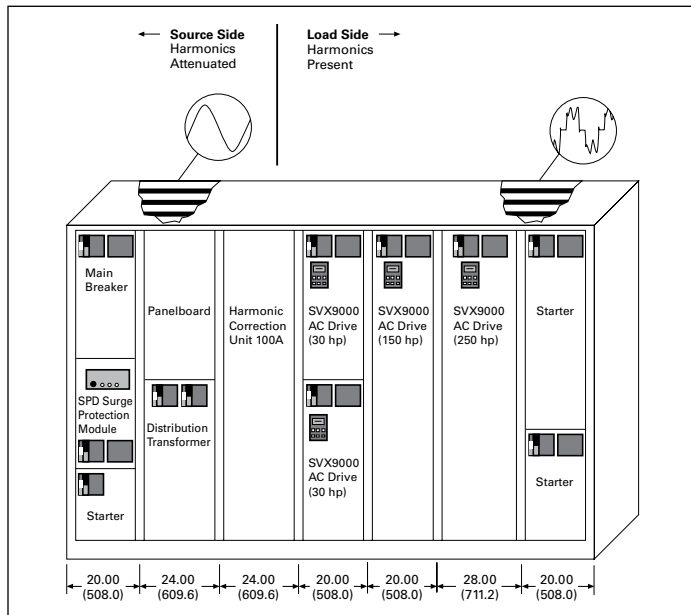

Figure 29.1-2. Clean Control Center with Active Harmonic Control—
Dimensions in Inches (mm)

Note: As seen by the upstream electrical system—compliance to the most stringent standards of IEEE 519 is ensured.

Dimensions

Not to be used for construction purposes unless approved.

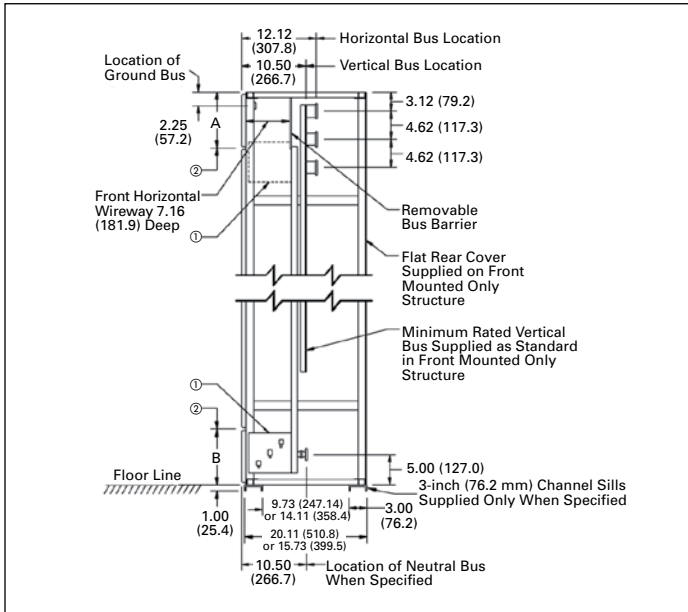

Figure 29.1-4. Side View A—Front Mounted Only—Dimensions in Inches (mm)

- ① Master terminal block assembly furnished for Type C wiring only. When location not specified, MTB supplied at the bottom.
- ② Standard structure arrangement in front
Without MTB; A and B = 9.00 inches (228.6 mm)
With MTB at bottom; A and B = 9.00 inches (228.6 mm)
With MTB at top; A = 15.00 inches (381.0 mm),
B = 3.00 inches (76.2 mm)

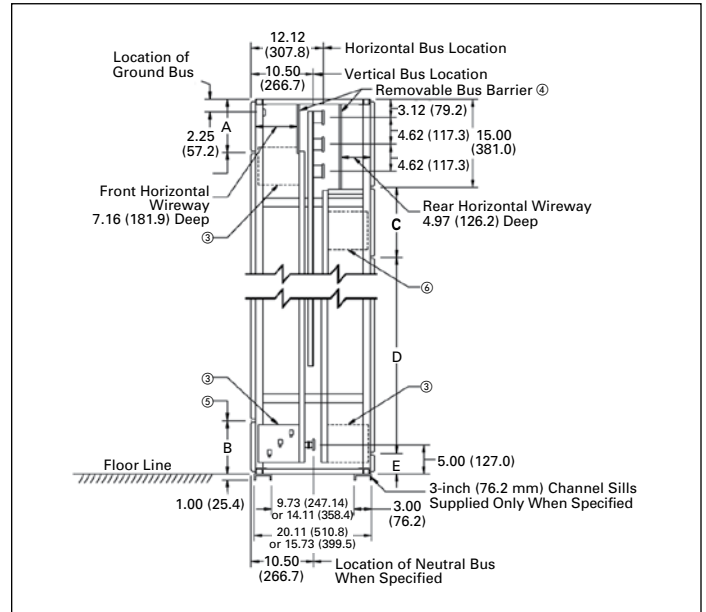

Figure 29.1-5. Side View B—Front and Rear Mounted—Dimensions in Inches (mm)

- ③ Master terminal block assembly furnished for Type C wiring only. When location not specified, MTB supplied at the bottom.
- ④ Rear horizontal bus barrier not supplied with front mounted only structure.
- ⑤ Standard structure arrangement in front
Without MTB; A and B = 9.00 inches (228.6 mm)
With MTB at bottom; A and B = 9.00 inches (228.6 mm)
With MTB at top; A = 15.00 inches (381.0 mm), B = 3.00 inches (76.2 mm)
- ⑥ Standard structure arrangement in rear
Without MTB; C = 9.00 inches (228.6 mm),
D = 72.00 inches (1828.8 mm), E = 3.00 inches (76.2 mm)
With MTB at bottom; C = 0, D = 66.00 inches (1676.4 mm),
E = 9.00 inches (228.6 mm)
With MTB at top; C = 12.00 inches (304.8 mm),

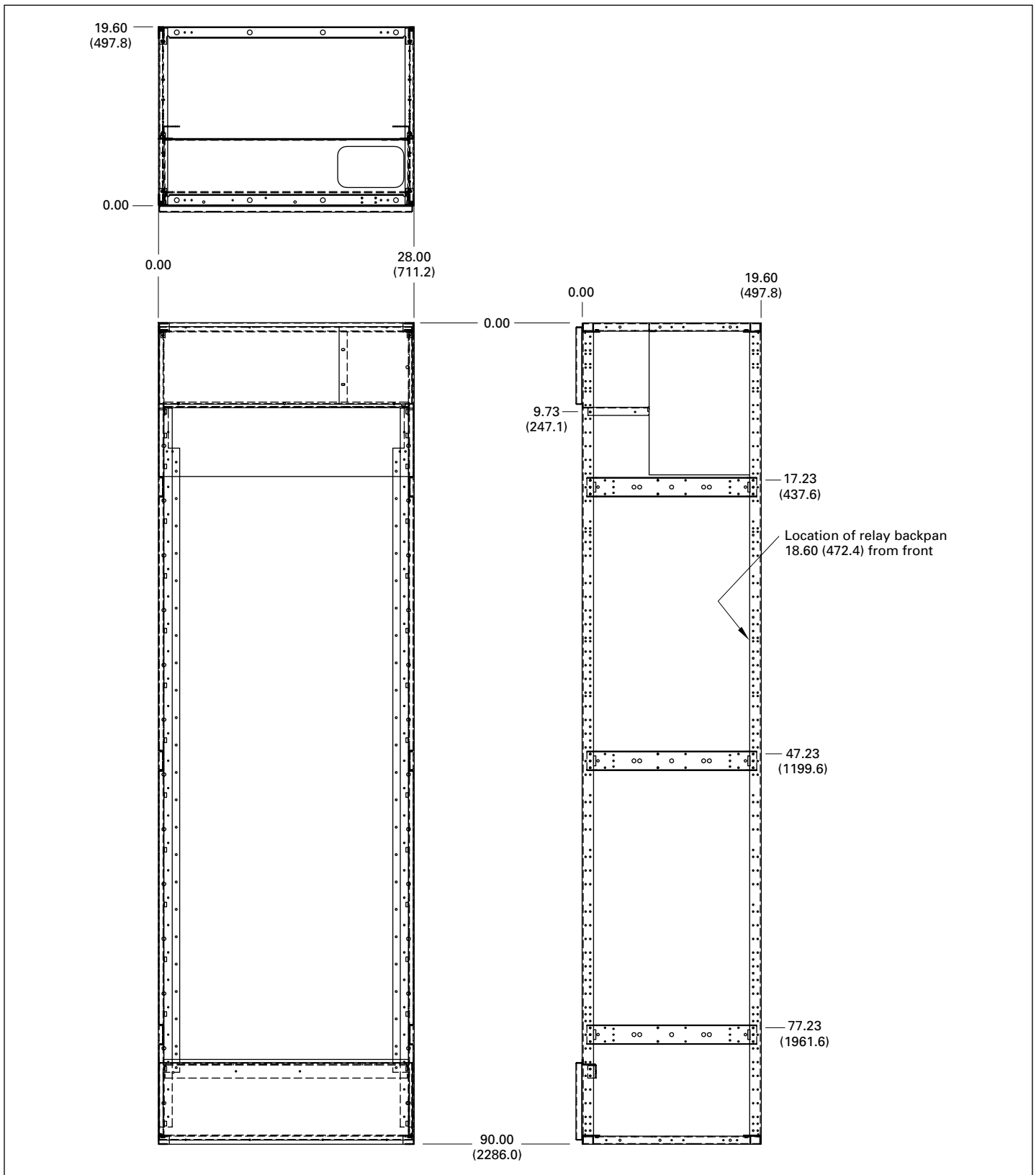
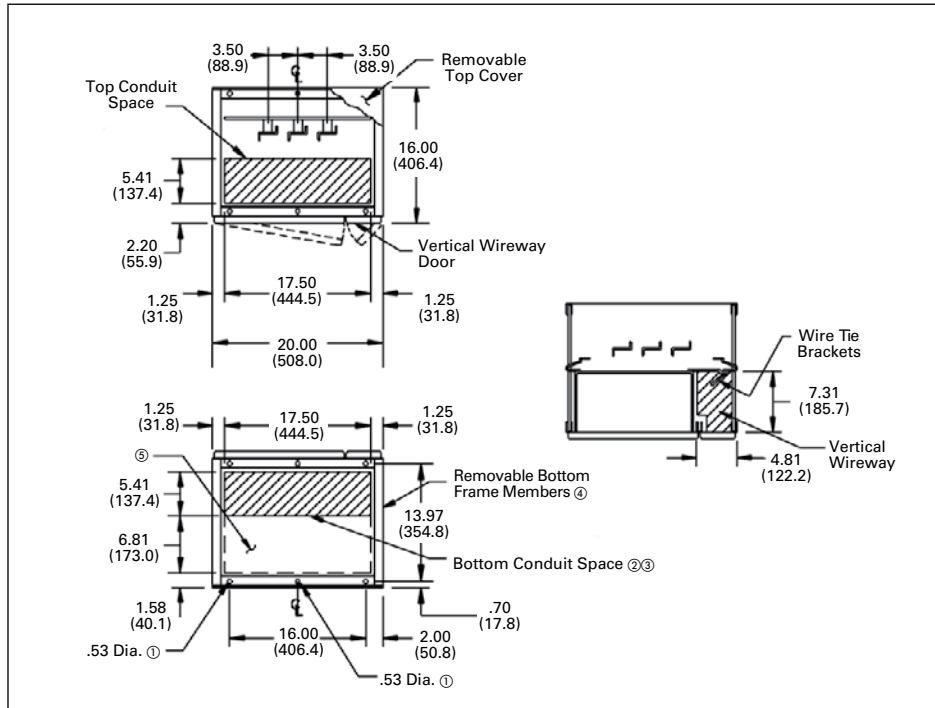

Figure 29.1-6. Relay Structure (28.00 inches [711.2 mm] wide and 20.00 inches [508.0 mm] deep shown)



- ① Minimum length of anchor bolt
2.00 inches (50.8 mm) 0.36 inches (9.1 mm)—16 recommended.
- ② Recommended maximum conduit height above floor line 3.50 inches (88.9 mm).
- ③ Maximum conduit space with channel sills
17.50 x 9.73 inches (444.5 x 247.1 mm).
- ④ For multiple structure assemblies. Either one or both of these members are removed to provide maximum unrestricted conduit space at bottom. Not to be removed for seismic.
- ⑤ This conduit space not recommended when neutral bus required. Otherwise available.
- ⑥ Top rear conduit space not recommended for conduit entry in FMO structure.

See Side View A Page 29.1-41 for vertical dimensions.

Figure 29.1-7. 20.00 Inches (508.0 mm) Wide, 16.00 Inches (406.4 mm)—Deep-Front Mounted Only (FMO)—Dimensions in Inches (mm)

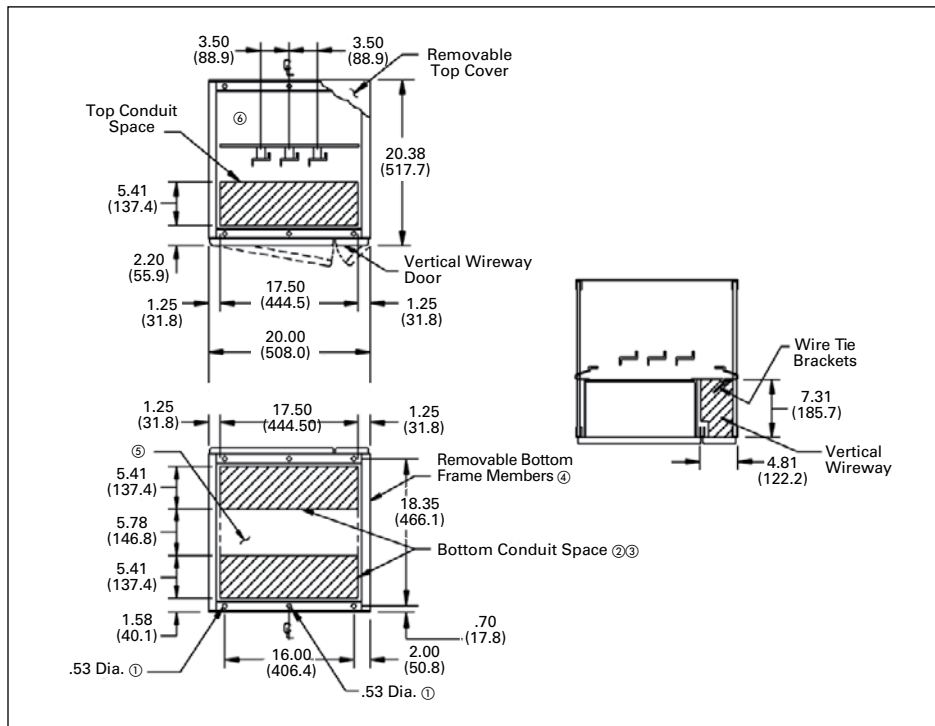
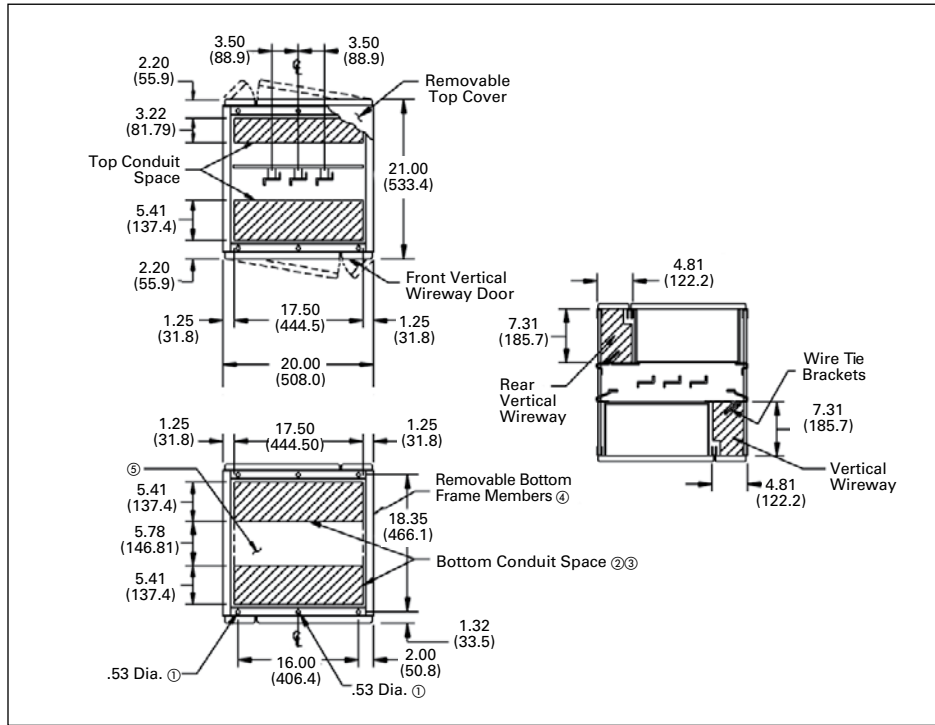

Figure 29.1-8. 20.00 Inches (508.0 mm) Wide, 21.00 Inches (533.4 mm)—Deep-Front Mounted Only (FMO)—Dimensions in Inches (mm)

Not to be used for construction purposes unless approved.



- ① Minimum length of anchor bolt
2.00 inches (50.8 mm) 0.36 inches (9.1 mm)—16 recommended.
- ② Recommended maximum conduit height above floor line 3.50 inches (88.9 mm).
- ③ Maximum conduit space with channel sills
17.50 x 14.11 (444.5 x 358.4) in 21.00-inch (533.4 mm) deep structure.
7.50 x 9.73 inches (190.5 x 247.1 mm) in 16.00-inch (406.4 mm) deep structure.
- ④ For multiple structure assemblies. Either one or both of these members are removed to provide maximum unrestricted conduit space at bottom. Not to be removed for Seismic.
- ⑤ This conduit space not recommended when neutral bus required. Otherwise available.
- ⑥ Channel sills supplied only when specified. For seismic loads, channel sills if required must be embedded so top of channel sill is still at floor level.

See Side View B Page 29.1-41 for vertical dimensions.

Figure 29.1-9. 20.00 Inches (508.0 mm) Wide, 21.00 Inches (533.4 mm) Deep—Front- and Rear-Mounted—Dimensions in Inches (mm)

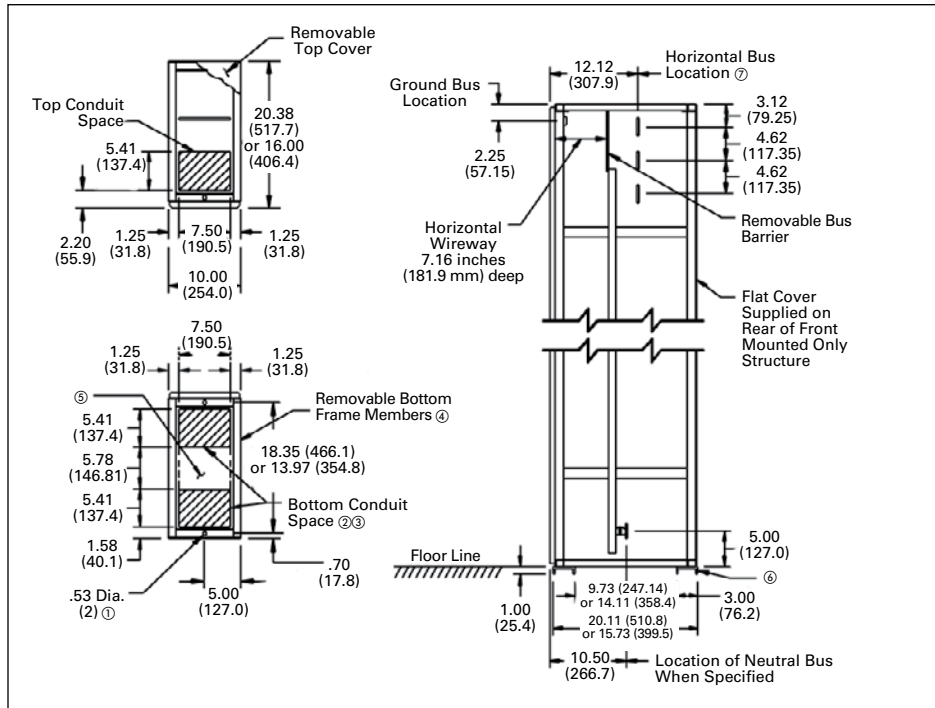

Figure 29.1-10. 10.00 Inches (254.0 mm) Wide, 16.00 or 21.00 Inches (406.4 or 533.4 mm) Deep—Transition Structure—Dimensions in Inches (mm)

Not to be used for construction purposes unless approved.

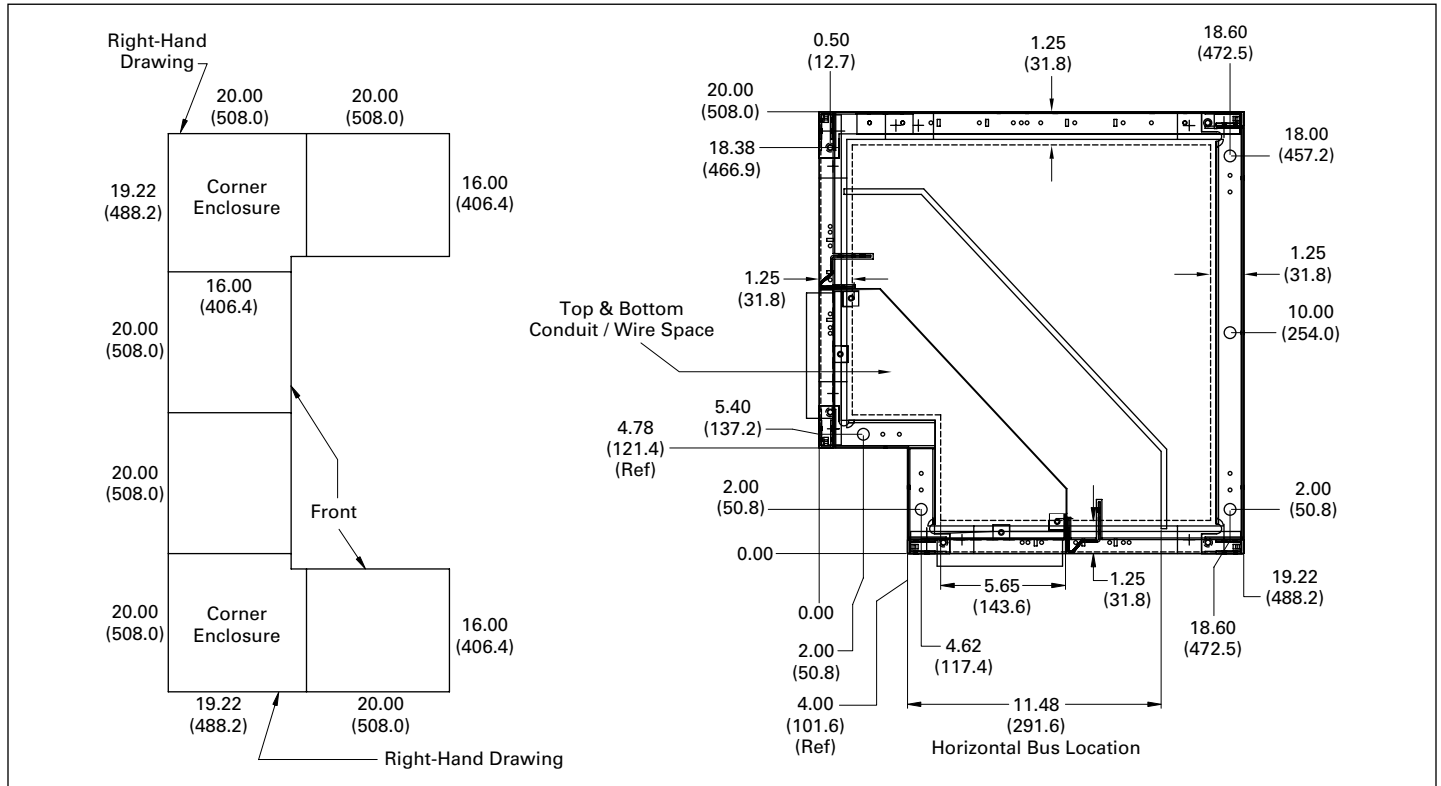

Figure 29.1-11. 16.00-Inch (406.4 mm) Deep—Front-Mounted Corner Structure (inside corner shown; consult factory for outside corner option)

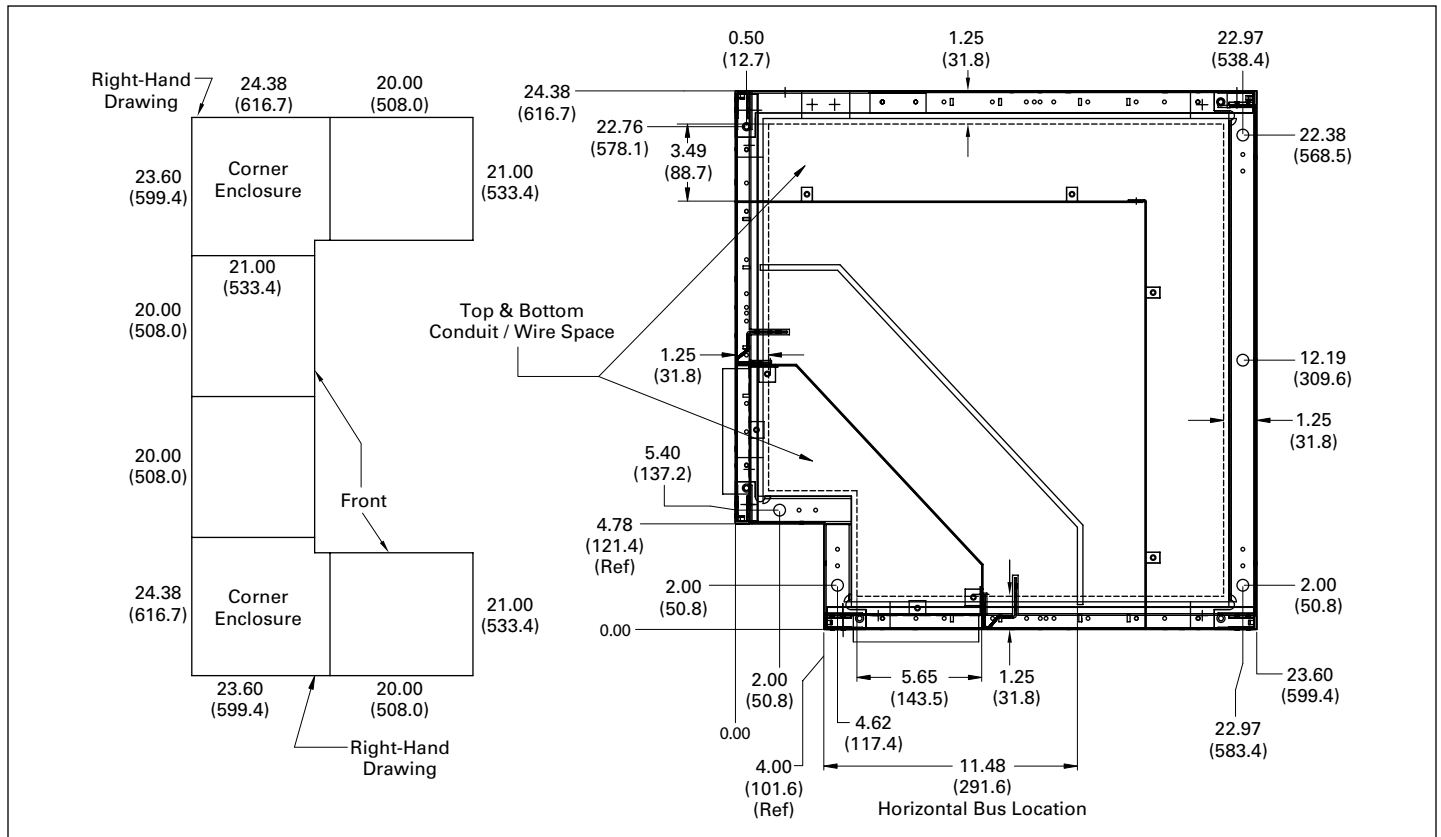

Figure 29.1-12. 21.00-Inch (533.4 mm) Deep—Front- and Rear-Mounted Corner Structure

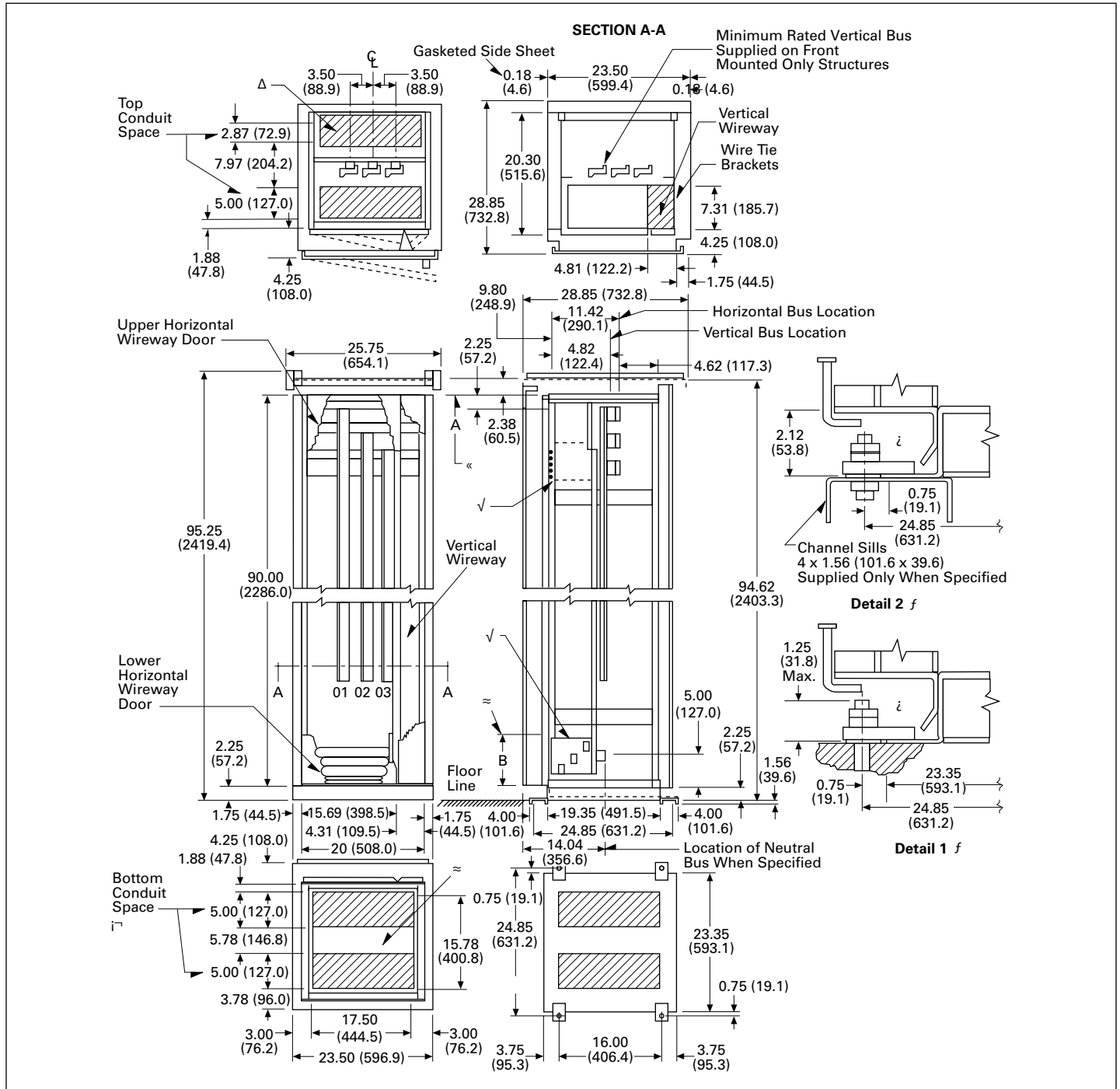

Figure 29.1-13. Freedom and Freedom FlashGuard Motor Control Center Outline and Floor Plan NEMA 3R 28.85-Inch (732.8 mm) Deep Structure—Dimensions in Inches (mm)

- ① Minimum length of anchor bolt 2.00 inches (50.8 mm). 38.00 (9.7 mm)—16 recommended.
- ② Recommended maximum conduit height above floor line 3.50 inches (88.9 mm).
- ③ Maximum conduit space with channel sills 15.78 x 16.6 inches (400.8 x 421.6 mm).
- ④ Master terminal block assembly furnished for type “C” wiring only. When location not specified MTB supplied at the bottom.
- ⑤ Recommended standard anchor bolting for Detail 1. When channel sills are used, see Detail 2.
- ⑥ This conduit space is not recommended when neutral bus is required. Otherwise available.
- ⑦ Top rear conduit space is not recommended for conduit entry in front mounted only structure.
- ⑧ Standard structure arrangement (in front) without master terminal block, A and B—9.00 inches (228.6 mm). With master terminal block at bottom, A and B—9.00 inches (228.6 mm). With master terminal block at top: A—15.00 inches (381.0 mm), B—3.00 inches (76.2 mm).

Note: Rear horizontal bus barrier is not supplied with front-mounted only structure.

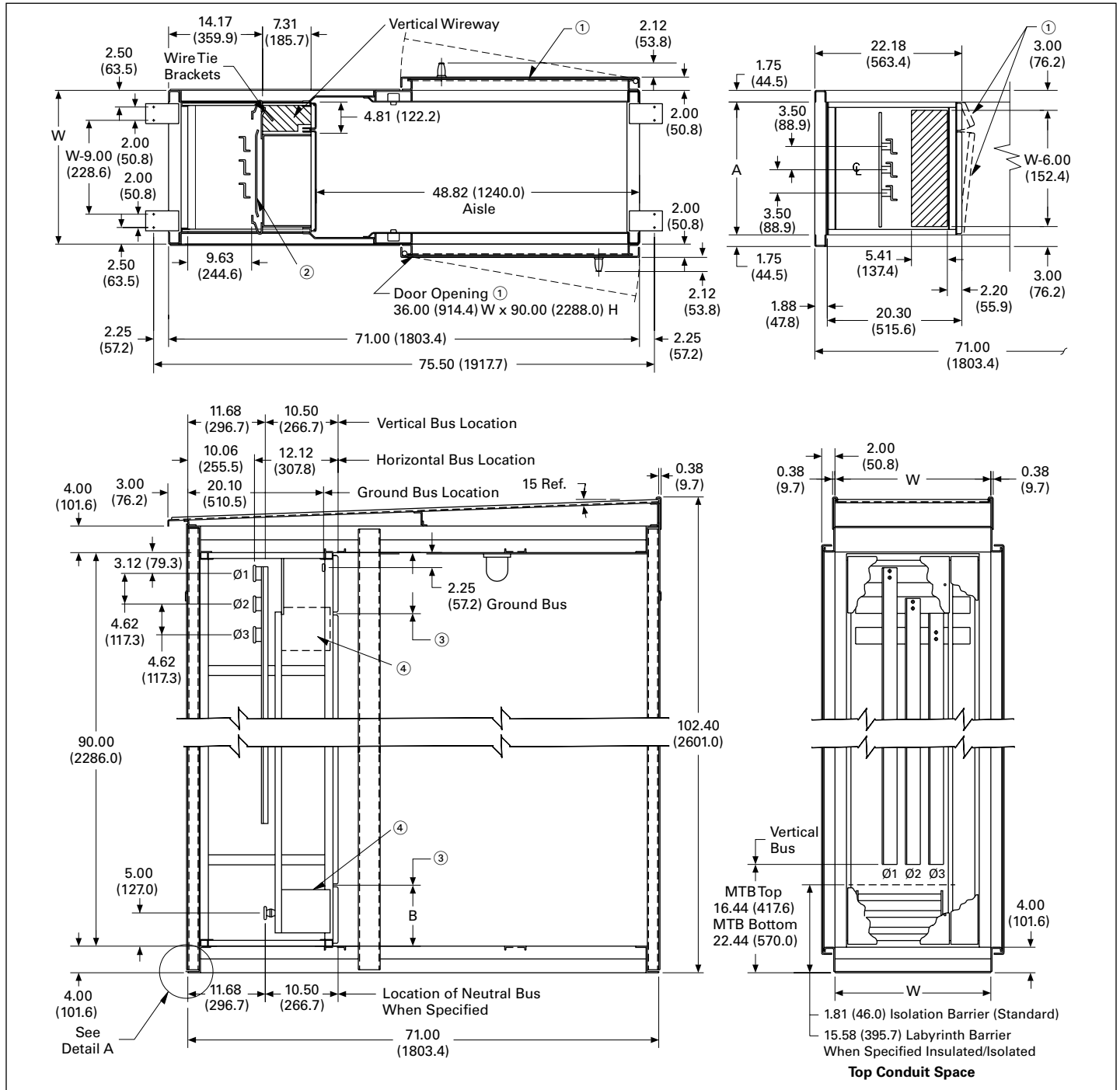

Figure 29.1-14. Freedom and Freedom FlashGard NEMA 3R Walk-In Aisle Structures—Dimensions in Inches (mm)

- ① All doors open minimum of 105°.
- ② Rear vertical bus barrier not supplied with front-mounted only structure.
- ③ Standard structure arrangement (in front) without master terminal block, A and B—9.00 inches (228.6 mm). With master terminal block at bottom, A and B—9.00 inches (228.6 mm). With master terminal block at top: A—15.00 inches (381.0 mm), B—3.00 inches (76.2 mm).
- ④ Master terminal block assembly furnished for type “C” wiring only. When location is not specified MTB is supplied at the bottom.

Note: Minimum rated vertical bus supplied as standard. Rear conduit space not recommended for conduit entry in front mounted only structure. Top rear conduit space not recommended for conduit entry in front mounted only structure.

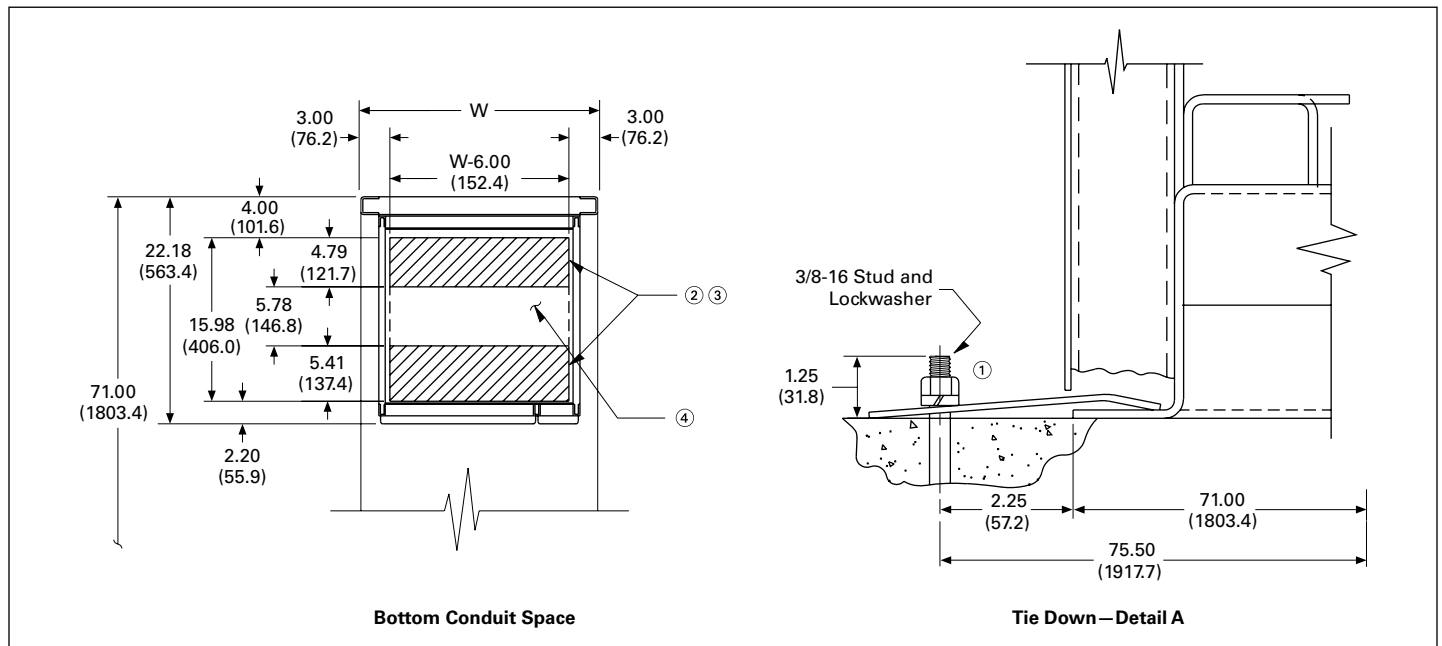

Figure 29.1-15. Freedom and Freedom FlashGard NEMA 3R Walk-In Aisle Structures—Dimensions in Inches (mm)

- ① Minimum length of anchor bolt above grade 1.25 (31.75) (0.38-16 grade 5 torqued at 31 lb ft (43.4 Nm).
- ② Recommended maximum conduit height above floor line 5.50 inches (139.7 mm).
- ③ Maximum conduit space B.
- ④ This conduit space not recommended when a neutral bus is required. The space is otherwise available.

Table 29.1-42. Dimensions in Inches (mm)

Outdoor Structure Width (W)	Indoor Structure Width (A)	Maximum Conduit Space (B)
23.50 (596.9)	20.00 (508.0)	17.50 x 15.98 (444.5 x 405.9)
27.50 (698.5)	24.00 (609.6)	21.50 x 15.98 (546.1 x 405.9)
31.50 (800.1)	28.00 (711.2)	25.50 x 15.98 (647.7 x 405.9)
35.50 (901.7)	32.00 (812.8)	29.50 x 15.98 (749.3 x 405.9)

Weights

Table 29.1-43. Typical Weights in lb (kg) ⑤

Description	Weight
16.00-inch (406.4 mm) deep x 20.00-inch (508.0 mm) wide structure ⑥	200 (91)
21.00-inch (533.4 mm) deep x 20.00-inch (508.0 mm) wide structure ⑥	260 (118)

Adder for Horizontal Bus

800 A	10 (5)
1000 A	15 (7)
1200 A	18 (8)
1600 A	24 (11)
2000 A	30 (14)
2500 A	38 (17)
3200 A	49 (22)

Adder for Vertical Bus

600 A	30 (14)
800 A	40 (18)
1200 A	60 (27)

Adder for Units Freedom—Inches (mm)

12.00 (304.8)	25 (11.4)
18.00 (457.2)	40 (18)
24.00 (609.6)	63 (29)
30.00 (762.0)	77 (35)
36.00 (914.4)	100 (45)

⑤ Example: 21.00 inches deep NEMA 1, 2000 A horizontal bus, 600 A vertical bus, two Size 1 starters, one Size 3 starter.
 $260 + 30 + 30 + (2 \times 25) + 40 = 410$ lbs

⑥ Weight for NEMA 1 structure with 600 A horizontal and 300 A vertical bus.

Heat Loss

Table 29.1-44. Typical Heat Loss Data ①

Description	Current (A)	Loss (W)
Vertical Sections	600	200
Horizontal Bus	800	300
and Ampacity	1200	500
	1600	700
	2000	1000
	2500	1400
	3200	2050

Space Heaters	Loss (W)
Space heaters	500

Starters	Loss (W)	
	C306	C440/C441/C445
FVNR size 1	40	30
FVNR size 2	60	50
FVNR size 3	100	90
FVNR size 4	130	120
FVNR size 5	230	220
FVNR size 6	400	390

AFDs			
SVX	DG1	hp (VT)	Loss (W)
FR4	FR1	7.5	140
FR5	FR2	20	400
FR6	FR3	40	800
FR7	FR4	75	1400
FR8	FR4	150	2800
FR9	FR5	250	4000
FR10	—	400	6250

Power Breakers	Amps	Loss (W)
MDN-608 (Fixed)	800	45
MDN-612 (Fixed)	1200	110
MDN-616 (Fixed)	1600	180
MDS-C08 (Drawout)	800	60
MDS-C16 (Drawout)	1600	240
MDS-C20 (Drawout)	2000	380
MDS-C32 (Drawout)	3200	800

Series C Molded Case Breakers	Amps	Loss (W)
FD	150	60
KD	400	175
LD	600	225
ND	800	87
ND	1200	210
RK	1600	220
RD	2000	270
RD	2500	400

Series G Molded Case Breakers	Amps	Loss (W)
EG	125	50
JG	250	75
LG	600	225
NG	800	87
NG	1200	210
RG	1600	220
RG	2000	270
RG	2500	400

① The starters are using the C306 bi-metal overload relay.

Eaton
 1000 Eaton Boulevard
 Cleveland, OH 44122
 United States
 Eaton.com

© 2020 Eaton
 All Rights Reserved
 Printed in USA
 Publication No. DG043001EN / Z23483
 February 2020



Eaton is a registered trademark.

All other trademarks are property of their respective owners.