

Low-voltage power distribution and control systems > Automatic transfer switches >

# Molded case type transfer switches

## Contents

<b>General Description</b> . . . . .	<b>25.2-2</b>
Product Configuration . . . . .	25.2-2
Design Highlights . . . . .	25.2-2
Standard Features (ATS) . . . . .	25.2-2
Optional Features (ATS) . . . . .	25.2-3
Assembly Ratings . . . . .	25.2-3
Enclosure Structure . . . . .	25.2-5
NEMA Enclosure Types . . . . .	25.2-5
Power Connections . . . . .	25.2-5
Cable Ingress and Access . . . . .	25.2-5
<b>Devices</b> . . . . .	<b>25.2-6</b>
Molded Case Switch/Circuit Breaker . . . . .	25.2-6
ATC-900 Automatic Controller . . . . .	25.2-8
ATC-300+ Automatic Controller . . . . .	25.2-12
HMi Remote Annunciator Controller . . . . .	25.2-13
Communication . . . . .	25.2-13
Advanced Metering . . . . .	25.2-14
Surge Protection . . . . .	25.2-14
Control Power Transformer . . . . .	25.2-14
Thermographic Imaging . . . . .	25.2-14
<b>Layouts and Dimensions</b> . . . . .	<b>25.2-15</b>
Standard Layout . . . . .	25.2-15
Dimensions and Weights . . . . .	25.2-16
<b>Application Data</b> . . . . .	<b>25.2-17</b>
Usual Environmental Conditions . . . . .	25.2-17
Unusual Environmental Conditions . . . . .	25.2-17
Heat Loss . . . . .	25.2-17
<b>Application Fundamentals</b> . . . . .	<b>25.2-18</b>
Transfer Switches . . . . .	25.2-18
UL 1008 Standard . . . . .	25.2-25
NFPA 70 System Installation Types . . . . .	25.2-27



# EATON

Powering Business Worldwide



More about this product  
[Eaton.com/ats](https://Eaton.com/ats)



Complete library of design guides  
[Eaton.com/designguides](https://Eaton.com/designguides)

## General Description



**Service Entrance Rated Molded Case Type  
Automatic Transfer Switch (ATS)**

Eaton's molded case type automatic transfer switch, with self-protecting main contacts, is designed to provide unmatched withstand close-on performance for use in emergency, legally required, optional standby, and critical operation power systems requiring open transition.

Transfer switches can be configured with overcurrent protection and a service entrance rating.

Standard and custom configurations are available.

## Product Configuration

- Automatic, non-automatic, and manual operation
- Open transition
- Two-, three- and four-pole
- 30–1000 A
- Single- and three-phase
- Up to 600 Vac, 3- or 4-wire
- 50/60 Hz
- NEMA® 1, 3R, 4X, 12 and open frame
- Fixed mounting
- Service entrance rated

## Design Highlights

- High short-circuit withstand closing current rating
- Overcurrent protection with thermal magnetic trip for normal and/or emergency power source
- Self-protecting main contacts
- Service entrance design marked for use at 100% of amperage rating and fully UL® 1008 Listed
- Integrated circuit breaker distribution panel
- Automatic transfer control
- UL 1008 and CSA® Listed
- Electrical and manual operation
- Quick make / quick break
- Manual transfer under load with permanently affixed handle
- Front accessible
- Field selectable, multi-tap control power transformer
- Switched (fully rated) or solid neutral
- Electrical and mechanical interlocks
- Top/bottom/side cable entry
- Internal deadfront cover
- Wall-mount enclosure types

## Standard Features (ATS)

- ATC-900 controller (ATC-300+, ATC-100 configurations available)
- Color liquid crystal display (LCD)
- Keypad navigation
- Mimic bus with LED indication
  - Source available
  - Source connected
  - Preferred source
- Source sensing
  - Undervoltage/overvoltage
  - Underfrequency/overfrequency
  - Phase sequence
  - Voltage unbalance/phase loss
  - Negative sequence voltage detection
- Dual automatic plant exercisers
  - Load/no load engine test
  - Daily, 7, 14, 28-day
  - Calendar date
  - Engine runtime
- Load sensing
  - Residual voltage decay
- Programmable time delays
  - Engine start
  - Normal to emergency
  - Emergency to normal
  - Engine cool-down
  - Emergency engine fail
  - Pre-/post-transfer
  - Source disconnect/reconnect
  - Neutral position
- Source available relay outputs
- Auxiliary position contacts
- Engine start contacts
- Programmable I/O
  - Control inputs (multipurpose)
  - Relay outputs (multipurpose)
- System diagnostics and help
- Serial communication (Modbus®)
- USB port
  - Power quality data and setpoint download/upload
  - Firmware field update
- Password protection
- Silver-plated bus
- Mechanical lug terminals

## Optional Features (ATS)

- Dedicated operator control (selector switch/pushbutton)
- Load metering (integral to controller)
  - Current
  - Power (kW, kVA, kvar)
  - Power factor
- Temperature-controlled heater element
- Surge protection device
- Advanced power quality metering
- Ethernet communication
- Programmable I/O (up to 20 control inputs and 20 relay outputs)
- 24 Vdc or 120 Vac control supply power provision
- HMI remote annunciator controller
- Compression lug terminals

## Assembly Ratings

- Continuous current (amperes)— 100% rated:  
30, 70, 100, 150, 200, 225, 300, 400, 600, 800, 1000
- System voltage (ac): 120, 208, 220, 240, 380, 415, 480, 600
- Operating frequency (Hz): 50, 60
- UL 1008 withstand closing current (when protected by fuse):  
200 kA short circuit ① (600V)
- UL 1008 withstand closing current rating (when protected by circuit breaker):
  - 100 kA short circuit ① (240 V)
  - 65 kA short circuit ① (480V)
  - 35 kA short circuit ① (600V)
- Certifications:
  - UL 1008 Listed
  - CSA 22.2, No. 178 Listed
  - Seismic—OSHPD, IBC, CBC, UBC zone 4
  - NEMA 1, 3R, 4X, 12

① Applicable for select product configurations.

**Table 25.2-1. UL 1008 Withstand and Closing Current Ratings (Molded Case Type ATS)**

Transfer Switch Rating (A)	Frame	Short-Circuit Withstand Closing Current Rating (kA)			When Protected by a Specific Fuse Manufacturing and Type Based		
		240 Vac Max. (kA)	480 Vac Max. (kA)	600 Vac Max. (kA)	600 Vac Max. (kA)	Fuse Class	Max. Fuse Size (A)
30–100	HFD	100	65	25	200	J,T	200
150–225	HFD	100	65	25	200	J,T	400
150–400 ②	HKD	100	65	35	200	J,T	400
					100	R	400
						J,T	600
400–600	HLD	100	65	35	200	J	600
						T	800
					100	R	600
600–800	HMD	100	65	35	100	L	800
						L	1200 ③
600–1000	HNB	65	50	25	200	L	1600

② HKD with 400 A rating only available for single-phase, two-pole, 240/120V or 208/120V configurations with ATC-300+ controller logic.

③ 480V maximum.

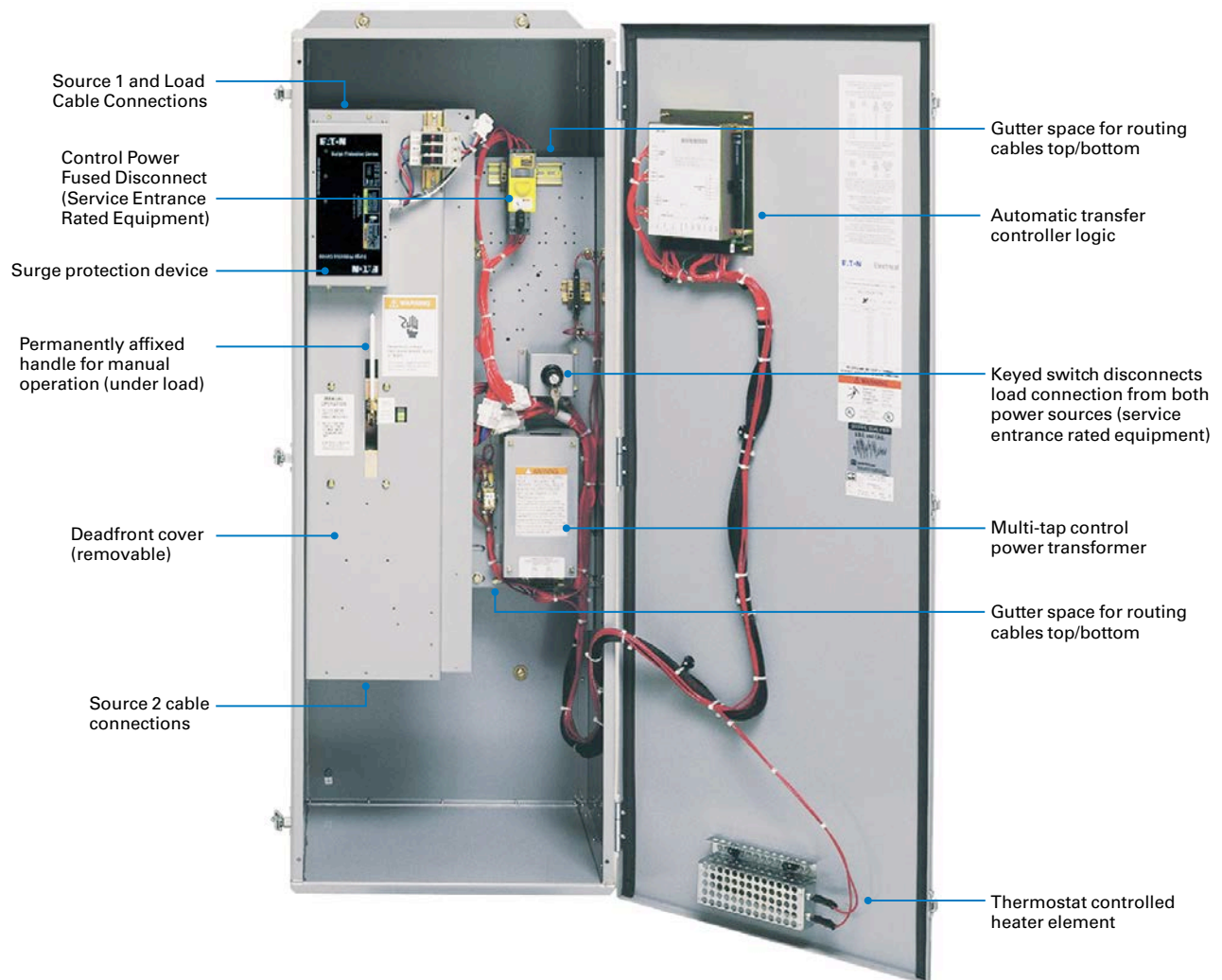

***Service Entrance Rated Molded Case Type Automatic Transfer Switch (ATS)***

## Enclosure Structure

### Standard Finish

Gray finish (ANSI 61) is applied to interior and exterior surfaces using an automated electrostatic powder coat system that includes spray de-grease and clean, spray rinse, iron phosphate spray coating spray rinse, non-chemical seal, oven drying, electrostatic powder spray paint coating and oven cure.

### Frame

A rugged frame, constructed of 12-gauge steel, provides structure rigidity.

### Door

The enclosure front door, constructed of 12-gauge steel is hinged and attached to the enclosure frame. The door is secured using a handle (or latch) with padlock provision. The automatic controller (when configured) and device option panel(s) are mounted within the front door. When the door is open, service personnel have access to the molded case switches/circuit breakers, terminal blocks, control wiring, electrical components and other accessories. Door swing is a minimum of 90 degrees.

### Mounting Points

The transfer switch assembly includes mounting points at the enclosure apex and base for attachment to a vertical surface (wall), and for larger enclosure sizes, anchoring to the floor.

## NEMA Enclosure Types

Molded case type transfer switch enclosures are available as NEMA 1, 3R, 12 or 4X.

Standard construction is steel with a gray finish (ANSI 61) applied to all interior and exterior surfaces. Alternatively, 304 or 316 grade stainless steel, with a mill or painted finish, can be provided for corrosive environments.

### Open frame type

For integration or retrofit applications, an open frame transfer switch provides a molded case switch/circuit breaker assembly with mechanical lugs mounted on a robust steel panel. A second steel panel includes a control power transformer, neutral assembly and related system components (relays). An automatic controller is mounted on a small device panel. System wire harnesses are included, and an optional 96-inch wire extension is available when integrating into larger spaces.

## Power Connections

UL listed screw-type mechanical lug terminals (Cu/Al) are the standard connection method for power cables. Lugs include an anti-rotation feature and are mounted directly on the power bus (load) and within the molded case switch/circuit breaker (normal/emergency). Alternatively, provisions can be provided for connection via two-hole compression lug terminals.

## Cable Ingress and Access

Molded case type transfer switches are designed to accommodate cable entry at the top/bottom/side of the enclosure.

Normal/load power connections are located closer to the top and emergency power connections are closer to the bottom. Gutter space is provided internally for routing cables between top and bottom.

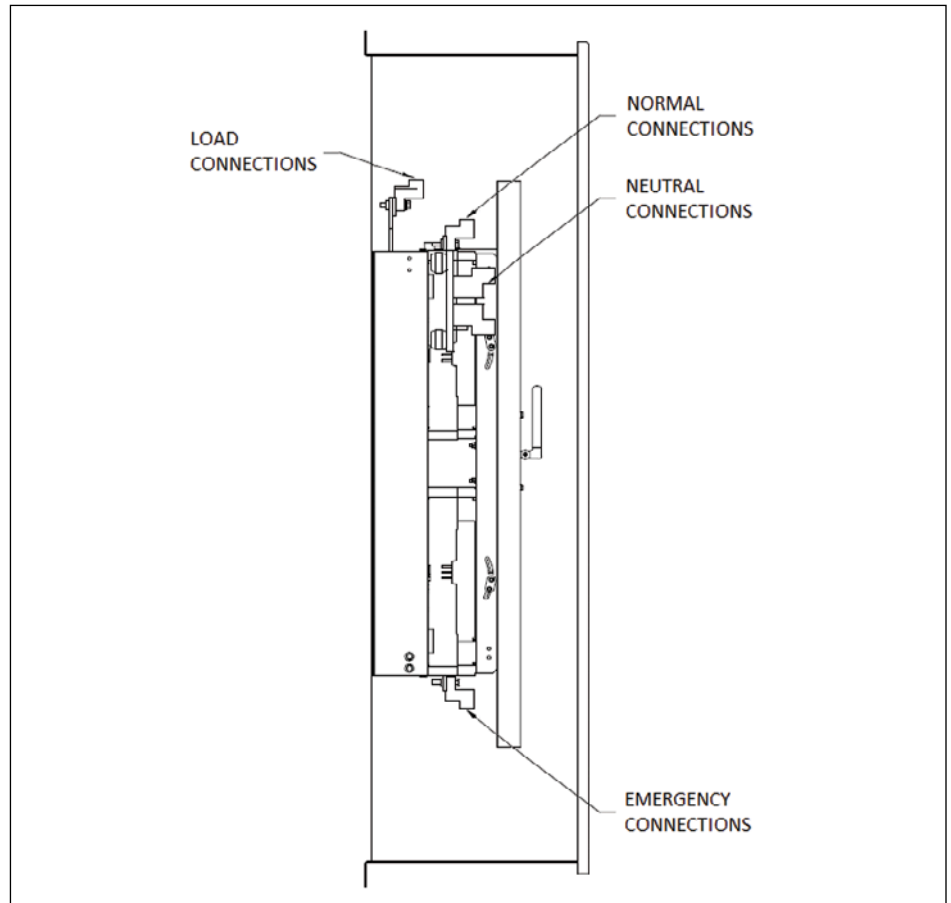

Table 25.2-2. Transfer Switch NEMA 1 Enclosure (Left Side View)



## Molded Case Switch/Circuit Breaker



Molded Case Switch (MCS)



Molded Case Circuit Breaker (MCCB)

Eaton molded case switches (MCS) are UL 489 devices that have a self-protecting high-magnetic trip element but do not provide thermal overcurrent protection. The magnetic trip is fixed, and factory preset to interrupt high short-circuit fault currents instantaneously at or above a preset level.

Molded case circuit breakers (MCCB) are UL 489 devices that include thermal overcurrent protection and a self-protecting high-magnetic trip setting. Thermal magnetic MCCBs provide both overload and short-circuit protection.

Internally, an MCS/MCCB is comprised of three main functional components:

- Trip element (magnetic or thermal-magnetic)
- Operating mechanism
- Arc extinguishers

### Trip Elements

Magnetic trip action is achieved with an electromagnet in series with the load current. This provides an instantaneous override tripping action when the current reaches a predetermined value.

Thermal trip action is achieved with a bimetal; heated by the load current. On a sustained overload, the bimetal will deflect, causing the operating mechanism to trip. Because bimetals are responsive to the heat emitted by the current flow, they allow a long-time delay on light overloads, yet they have a fast response on heavier overloads.

### Operating Mechanism

The function of the MCS/MCCB operating mechanism is to provide a means of opening and closing the main contacts. All mechanisms are of the quick-make, quick-break type and are “trip free.” “Trip free” mechanisms are designed so that the contacts cannot be held closed against an abnormal circuit condition and are sometimes referred to as an “over-center toggle mechanism.” The MCS/MCCB operating mechanism is driven by the permanently affixed handle.

### Arc Extinguishers

The function of the arc extinguisher is to confine, divide and extinguish the arc drawn between the opening contacts. It consists of specially shaped steel grids isolated from each other and supported by an insulating housing.

When the contacts are opened, the arc drawn induces a magnetic field in the grids, which in turn draws the arc from the contacts and into the grids. The arc is thus split into a series of smaller arcs and the heat generated is quickly dissipated through the metal. These two actions result in a rapid removal of ions from the arc, which hastens dielectric buildup between the contacts and results in rapid extinction of the arc.

### Rigid Housing

All the components of an MCS/MCCB are encased in a rigid housing constructed of durable high-strength insulating material with excellent dielectric characteristics able to withstand high-dynamic and thermal stresses. The physical frame size is a function of the MCS/MCCB amperage rating.

### Internal Accessories

Factory-installed plug-in accessories commonly used with molded case transfer switches include the following:

- Auxiliary switch contacts
- Bell alarm/lockout switch contacts

The auxiliary switch contacts provide position status of the main contacts and consist of one or two single-pole, double-throw (SPDT) switches assembled to a plug-in module. Each SPDT switch has one “A” and one “B” contact. When the MCS/MCCB main contacts are open, the “A” contact is open and the “B” contact is closed.

The alarm/lockout switch contacts provide trip status and consist of one or two single-pole, double-throw (SPDT) switches assembled to a plug-in module. Each SPDT switch has one “A” and one “B” contact. When there is a trip condition, the “A” contact closes and the “B” contact opens.

### Interrupt Rating

The interrupting capacity rating of an MCS/MCCB is the maximum amount of fault current it can safely interrupt without damage. An interrupting rating is provided in thousands of amperes (kA) and is typically referenced by the acronym kAIC.

It is important to note that the interrupt rating is specific to the MCS/MCCB component and it should never be confused with the UL 1008 withstand closing current rating of the transfer switch assembly. When applying a transfer switch in an electrical system, the withstand closing current rating must be equal to or greater than the available fault current calculated at the location of the transfer switch in the electrical circuit. Reference the section entitled ‘Withstand Closing Current Ratings’ later in this document for a more detailed discussion.



Thermal-Magnetic Trip Unit

**Mounting**

Molded case type transfer switches are constructed with a pair of molded case switches/circuit breakers fix mounted in a horizontal or vertical arrangement to a robust steel panel.

The normal power source feeds the line side of one MCS/MCCB and the emergency power source feeds the line side of the other MCS/MCCB. The MCS/MCCB load sides are electrically joined using silver-plated copper bus that feeds the load connection.

**Electric Operator**

For automatic and nonautomatic transfer switches, a unidirectional gear motor mechanism electrically operates a mechanical linkage that is directly coupled to the handle of each MCS/MCCB. Control power for electrical operation is derived from the power source to which the load is being transferred.

For automatic, non-automatic and manual transfer switches, a permanent handle is provided to manually drive the linkage as a backup means of operation (under load). An indicator wheel provides positional status information.

**Mechanical Interlocks**

The mechanical linkage, driven by the motor/handle, serves as a mechanical interlock and will not allow both MCS/MCCB devices to be closed simultaneously.

As a fail-safe, a second mechanical interlock is rear mounted to each of the MCS/MCCBs to prevent power source paralleling.



*Rear-Mounted Mechanical Interlock*

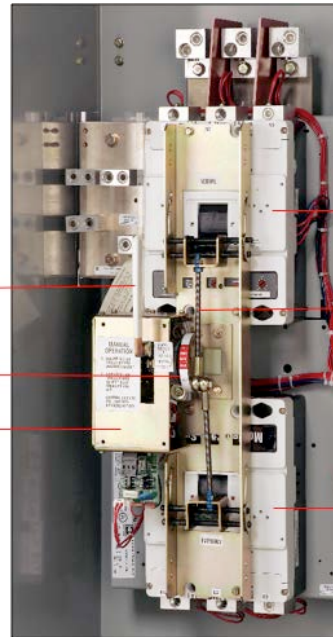

*MCS/MCCB Power Panel Assembly (Vertical Arrangement)*

**Integral Overcurrent Protection Advantages**

The utilization of a molded case circuit breaker, with an integral thermal-magnetic trip element, in an automatic transfer switch assembly has several advantages.

The first is the ability to eliminate an external circuit breaker on the incoming side of either power source or both. Without an integral trip element, should a fault occur on the load side of the transfer switch ahead of the load side protective device, the circuit breaker upstream of the source side of the transfer switch would perform its intended function and trip. The transfer switch controller logic would sense a loss of normal voltage on its line side, initiate an engine-generator start signal, and transfer the faulted load connection to the generator source, resulting in a trip of the generator circuit breaker.

A feature referred to as a “bell alarm” provides a secondary advantage to an integral trip element. This feature consists of a switch that changes state when the molded case circuit breaker automatically trips because of an overcurrent or fault condition.

When a molded case circuit breaker with integral trip element is utilized, the integral trip would trip under the load side fault condition, and the bell alarm contact will immediately initiate a lockout condition blocking the generator start signal, thus eliminating the application of a fault on the generator source.

**Endurance**

When molded case switches or circuit breakers are utilized in a transfer switch assembly, they are subject to thousands of cycles of operation per the rigorous testing outlined in the UL 1008 standard. For a more detailed discussion, reference the section “Life Expectancy” on **Page 25.2-26.**

## ATC-900 Automatic Controller

Eaton's ATC-900 brings intelligence, adaptability, enhanced supervisory and programming capabilities to Eaton's entire transfer switch product family.

The simple yet powerful user interface includes many intuitive features. The color display and mimic bus with LED indication provide enhanced operator visibility of transfer switch status and metering data. Front arrow keys allow for quick screen navigation, removal of codes and abbreviations avoid potential confusion, and refined data screens provide for ease of viewing and programming.

00 / 00 / 00		Main Menu			00 : 00 : 00	
	Source 1	Source 2	Load	Currents		
Vab	482 V	483 V	482 V	Ia	1002 A	
Vbc	479 V	482 V	479 V	Ib	1008 A	
Vca	480 V	478 V	480 V	Ic	997 A	
Freq	60.0 Hz	60.0 Hz	Hz			
Status	Good	Good				

**ATC-900 Main Menu Screen**

## Primary Features

- Monitor voltage and frequency of normal source, emergency source and load
- Self-acting load transfer between power sources
- Display of real-time and historical information
- Programmable setpoints
- User-configurable control inputs and relay outputs
- Dual engine start/shutdown signaling
- Dual programmable plant exercisers
- Integral load metering
- Detailed and time-stamped event log and history
- Advanced diagnostics and troubleshooting with pre-/post-event data capture
- Download of setpoints, event log and metering data via USB flash drive
- Upload of setpoints and firmware updates via USB flash drive
- Industry standard serial communication
- Symmetrical component calculation
- Record test data to comply with The Joint Commission, NFPA 99 and NEC (700, 701, 708) requirements
- Generator start contacts (Form C) provide means to comply with 695.14(F) and 700.10(D)(3) of the NEC (2017 and 2020)

**LED mimic diagram**  
Color-coded LEDs provide status indication. Source 1 Available (white) and Connected (green), Source 2 Available (amber) and Connected (red), Preferred Source (green).

**Display and main menu**  
Provides status at a glance. Source 1, Source 2, and Load status and metering data are displayed. Additional screens are easily accessed using navigation keys.

**Arrow key navigation**  
Right and left arrow keys are used to navigate menu options and up and down arrow keys are used to scroll screens and change setpoint values.

**USB port**  
Download/upload setpoints, events, statistics, meter data, and firmware.

**Unit status**  
LED (green) blinks, indicating that the ATC-900 is operating normally. If the LED is not lit or is on continuously, then a problem condition is indicated.

**Help**  
Displays controller firmware version and user tips.

**Lamp test**  
Pressing the Lamp Test pushbutton lights all LEDs and then displays ATC-900 information.

**Engine test**  
Performs an engine test using the programmed engine run and cool-down times. This is a password-protected feature.

**Bypass time delays**  
Pressing the Enter and Help pushbuttons simultaneously reduces the active programmed time delay to zero.



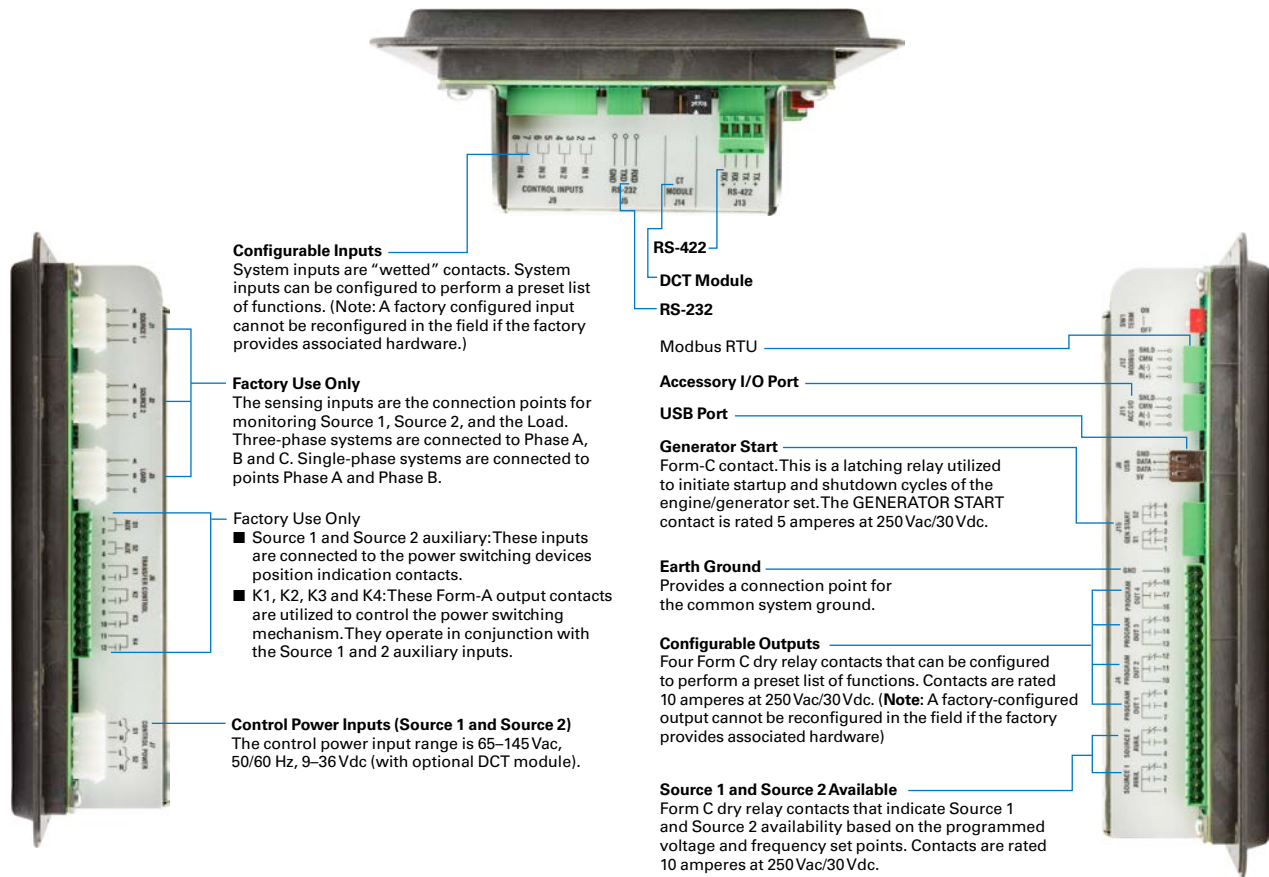

### Accessory Modules

The ATC-900 utilizes supporting hardware accessory modules to expand its functionality.

### Integral Metering and DC Supply Voltage

An optional DCT module mounts directly to the rear of the ATC-900 and supports the connection of three current transformers via shunting block termination to provide integral power metering (amps, kW, kVA, kvar, PF) complementing standard ATC-900 voltage and frequency monitoring.

24 Vdc can be supplied externally to keep the ATC-900 continuously powered and communicating when the normal and emergency sources are not available.



Load Metering					
Vab	482 V	Ia	1002 A	kW	789
Vbc	479 V	Ib	1008 A	kVAR	261
Vca	480 V	Ic	997 A	kVA	831
Freq	60.0 Hz			PF	.95

### Programmable Inputs/Outputs

The ATC-900 standard offering of four programmable inputs and four programmable outputs is expandable by adding I/O modules.

Each I/O module provides an additional four inputs (wetted, 24 Vdc at 10 mA) and four outputs (Form C rated 10 A at 250 Vac/30 Vdc). A maximum of four I/O modules can be daisy-chained for a total of 20 inputs and 20 outputs.



Setpoints - Programmable Inputs	
Input 1	Go To Emergency
Input 2	Emergency Inhibit
Input 3	Preferred Source
Input 4	Bypass Timers
Accessory I/O Modules 0	

**Programmable Input Functions**

- Monitor mode
- Bypass timer
- Lockout
- Manual retransfer
- Enable manual retransfer
- Slave
- Remote engine test
- Preferred source selection
- Go to emergency
- Emergency inhibit/load shed
- ATS on bypass
- Go to neutral position
- Closed transition disable
- Disabled

**Programmable Output Functions**

- Source 1 available
- Source 2 available
- Source 1 connected
- Source 2 connected
- ATS not in automatic mode
- General alarm
- ATS in test status
- Engine test aborted
- Engine cool-down in process
- Engine 1 start status
- Engine 2 start status
- Emergency inhibit on
- ATS on bypass
- Load sequence
- Selective load shed
- Load bank control
- Pre-/post-transfer
- Pre-transfer
- Post-transfer
- User remote control
- Health
- Waiting for source sync
- Disabled

**Fixed Output Functions**

- Source 1 available
- Source 2 available
- Engine start 1
- Engine start 2

**Symmetrical Components**

The ATC-900 calculates both positive and negative sequence components for voltage and current to determine when abnormal conditions exist that might otherwise go undetected.

An example is a single-phase loss (e.g., open feeder fuse) at the normal source, which would typically cause a transfer to the alternate source.

Once the normal source is unloaded, a condition can develop whereby the single-phase loss is masked due to an induced or “phantom” voltage. If undetected, this could result in a retransfer back to the normal source. Once the normal source is loaded again, the cycle can repeat itself, resulting in continuous power interruptions until the phase loss condition is corrected.

Through the calculation of symmetrical components, the ATC-900 is capable of detecting this abnormal condition and preventing transfer cycling. To protect mechanical loads from potential damage, the ATC-900 can disconnect the load from the normal source (immediately or after a time delay) until the alternate source becomes available.

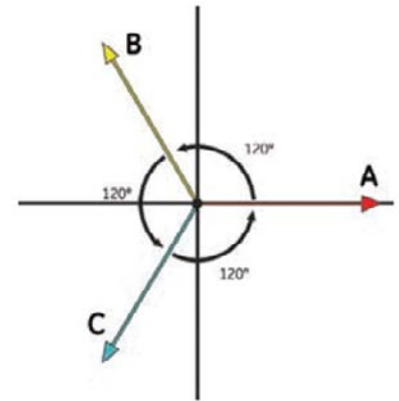

***ATC-900 Uses Negative Sequence Components to Detect Abnormal Conditions***

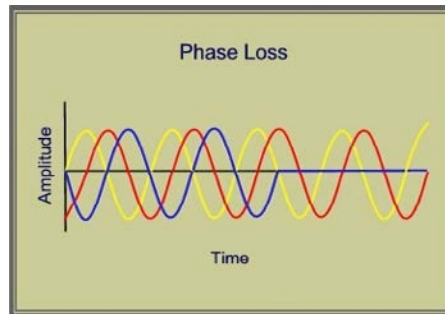

### Three Source Arrangement with Master-Slave

The master/slave functionality provides the ability to configure two independent automatic transfer switches in a three-source arrangement consisting of a utility and two generator sources (permanent or portable).

In this configuration, the engine start signal from the master ATS is wired directly to a programmed control input at the slave ATS. The engine start 1 and engine start 2 signals at the slave ATS are wired to the generators. The ATC-900 at the slave ATS requires a DCT module (fed by an external 24 Vdc supply) to keep the controller powered.

In the event of a utility power failure, the master ATS engine start relay closes signaling the slave ATS to start either a preferred generator (if designated) or both generators. Generator start and stop is managed by the slave ATS. Upon restoration of utility power, the master ATS engine start relay will open, signaling the slave ATS to begin generator shutdown.

### Load Management

The ATC-900 includes several features, enhancing a user's ability to manage load.

- **Integral load metering:** Monitor load power utilization and compare to baseline measurements
- **Selective load shed:** Drop and pickup non-essential loads when programmed kW threshold levels are reached
- **Emergency inhibit/load shed:** Inhibit or disconnect the load connection to emergency source
- **Pre-/post-transfer:** Control select loads during the transfer process
- **Load bank control:** Disengage a load bank connection from the emergency source upon loss of the normal source
- **Normal source disconnect/reconnect:** When an abnormal power condition is present at the normal source, disconnect the load to prevent potential damage
- **Emergency source disconnect/reconnect:** When an abnormal power condition is present at the emergency source, disconnect the load to prevent potential damage

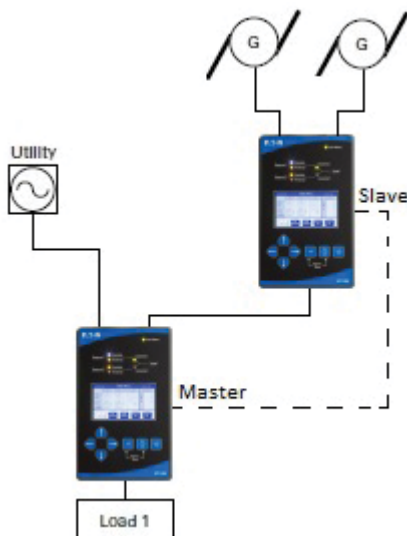

Master-Slave Configuration with ATC-900

**ATC-300+ Automatic Controller**

Eaton’s ATC-300+ is a comprehensive, multi-function, microprocessor-based automatic transfer switch (ATS) controller.

It is equipped with a two-line LCD menu and integrated keypad for displaying monitored parameters, programming setpoints, viewing messages and accessing help prompts in an easy to read format.

**Primary Features**

- Monitor voltage and frequency of normal source and emergency source
- Self-acting load transfer between power sources
- Display of real-time and historical information
- Programmable setpoints
- Control inputs and relay outputs
- Engine start/shutdown signaling (Form C contacts)
- Programmable plant exerciser
- Detailed and time-stamped event log and history
- Diagnostics and troubleshooting with pre-/post-event data capture
- Industry standard serial communication
- Generator start contacts (Form C) provide means to comply with 695.14(F) and 700.10(D)(3) of the NEC (2017 and 2020)

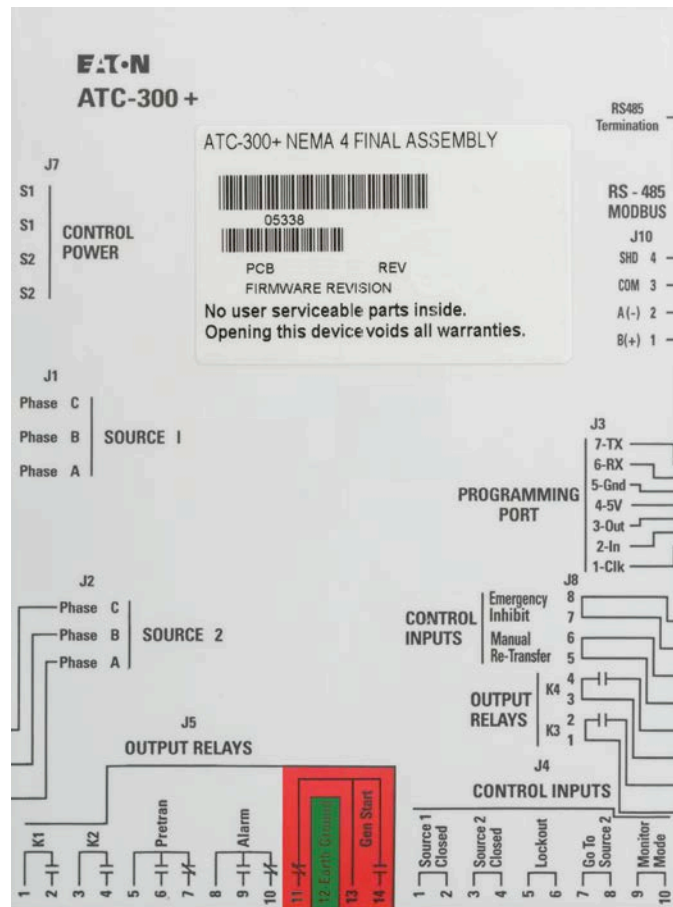

*ATC-300+ Controller (Rear View)*

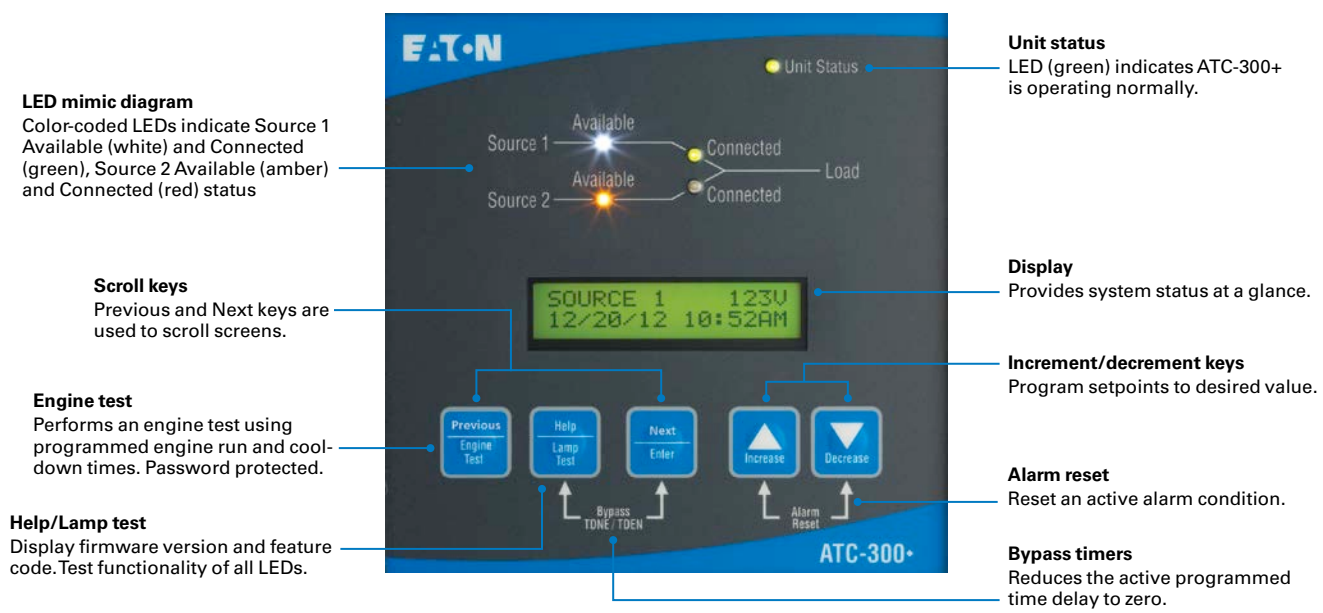



## HMi Remote Annunciator Controller

Tightening arc flash regulations and requirements for personal protective equipment are driving more and more end users toward the use of remote monitoring and control devices.

Eaton's HMi Remote Annunciator Controller offers a simple and cost-effective means of monitoring and controlling up to eight automatic transfer switches via serial or ethernet communication.

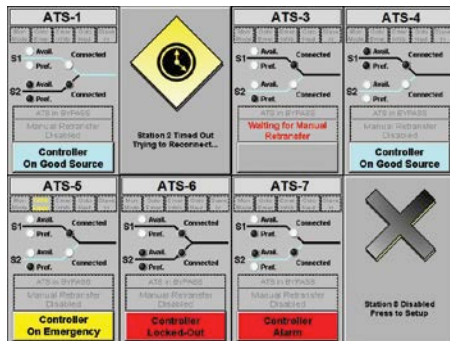

Using one intuitive touch screen interface, users can:

- Monitor source vitals and health
- Analyze metering and trend data of sources and load
- View and program transfer switch controller setpoints, control inputs and relay outputs
- Start and stop a generator engine test
- Initiate a transfer to the alternate source
- Bypass a time delay countdown
- Initiate a manual retransfer
- View and silence alarms
- Perform basic troubleshooting
- Monitor source synchronization during in-phase or closed transition
- View event history
- View the status of up to eight transfer switches on a single overview screen

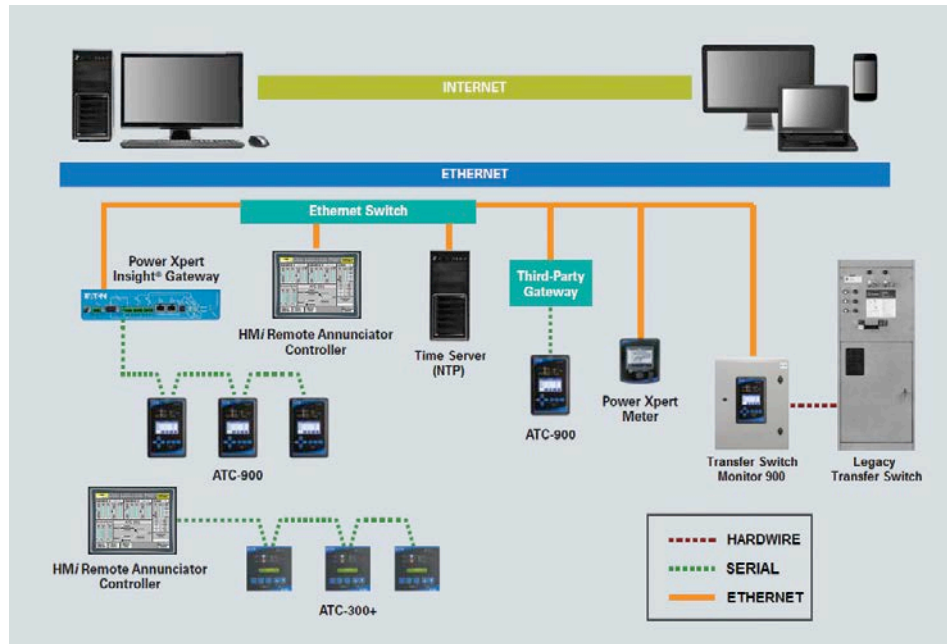
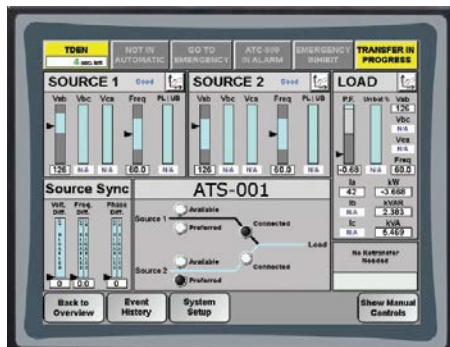

System Architecture

## Communication

Eaton transfer switch controllers include native support for serial communication and a Modbus register map is available for interfacing with a building management or power management system. When ethernet communication is desired, there are several modular options available. Modules are typically DIN rail mounted within the enclosure assembly but can be shipped loose.

The Power Xpert PXG 900 is a full-featured gateway and includes an embedded web server. See Eaton technical document TD152008EN for details.



Network protocols:

- ModbusTCP/IP
- HTTP and HTTPS
- DHCP
- BACnet/IP

The ELC-CAENET module is a basic serial to ethernet adapter and supports a variety of protocols. See Eaton document MN05002003E for details.



Network protocols:

- ModbusTCP/IP
- HTTP
- DHCP
- EtherNet/IP (Rockwell/A-B)

## Advanced Metering

Power Xpert power and energy meters, and Power Xpert Dashboard products allow owners and operators to interface with their equipment at varying levels of sophistication.

To learn more about Power Xpert Metering products that can be integrated into an Eaton transfer switch, see publication BR140001EN or visit [www.eaton.com/meters](http://www.eaton.com/meters).

## Surge Protection

Surge protection devices can easily be integrated within a transfer switch at the normal (utility) and/or the emergency (generator) power source connection(s).

The purpose of an SPD is to protect electrical and electronic equipment, such as the automatic controller, from damage and degradation due to short duration, high-energy transients. IEEE C62.41.2 describes a number of transient waveforms, with a duration in microseconds or milliseconds, that might be found in an electrical system.

While SPDs do an excellent job of mitigating voltage transients, they are not designed to provide continuous sinusoidal voltage regulation. When an SPD is subjected to a sustained overvoltage, there is a very real danger of the SPD being permanently damaged.

While power obtained from an electric utility typically has very good voltage regulation, a standby or emergency generator may not due to generator undersizing or use of a low-cost voltage regulator.

When specifying an SPD for use on the emergency (generator) side of a transfer switch, the following is an abbreviated list of recommendations. A more detailed discussion can be found in Eaton application paper AP01001003E.

- Utilize an SPD with a delta (3-wire + ground) voltage code for three-phase electrical equipment to improve reliability of the emergency power system
- Specify an SPD with a surge current capacity rating (kA) per the location categories outlined in the latest IEEE C62.41.1 standard. By example, a service entrance transfer switch is considered category C
- Specify a minimum nominal discharge current rating of 20 kA

SPDs are typically equipped with an audible alarm and a Form C relay contact for remote annunciation of status. Some models offer an optional surge counter with nonvolatile storage and reset button.

## Control Power Transformer

Transfer switches can easily be field configured for operation with different system voltages via a multi-tap control power transformer (CPT) with keyed quick-disconnect plugs.

Supported three-phase system voltages are 208, 240, 480, 600 Vac (domestic type) and 220, 230, 380, 415 Vac (international type). Either CPT type is available as 60 Hz or 50/60 Hz rated.

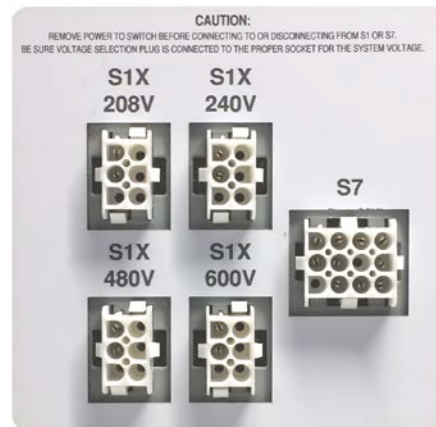

Multi-Tap Control Power Transformer  
(Domestic)

## Thermographic Imaging

Routine inspection of energized conductor terminations in electrical distribution equipment is commonly performed to ensure system reliability and uptime.

Over time, bus joints and cable terminations are often subject to recurring thermal expansion and contraction, which can eventually cause loosened connections resulting in excessive heat. If left unchecked, these "hotspots" can ultimately create an electrical hazard for personnel and/or lead to equipment failure.

One method for periodically verifying the integrity of conductor terminations is to conduct a thermographic scan using an infrared (IR) camera. Line-of-sight is needed between the IR camera and the target termination(s) being scanned, which often requires the equipment enclosure to be fitted with an IR window(s).

IR windows come in various shapes and sizes to accommodate differing target distances and IR camera equipment. A protective cover is typically provided to guard against impact. Based on application needs, power frame transfer switches can optionally be fitted with one or more IR windows as specified by the engineer.



IR Windows

In scenarios where the use of an IR camera is not plausible because of physical limitations, safety concerns or the inability to frequently perform inspections, alternative thermal surveillance technologies can be considered.

Thermal sensors (wired or wireless) are now available commercially and can be positioned within electrical equipment to provide unmanned, 24/7 monitoring of bus and cable connections. Although the idea of real-time monitoring is appealing, replacing a failed thermal sensor could prove challenging, especially in critical operation facilities.

## Standard Layout

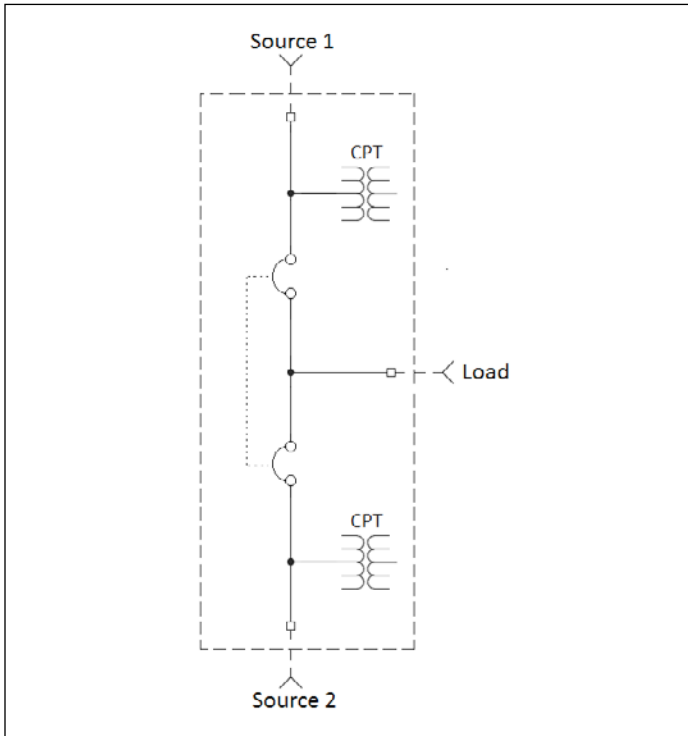

**Figure 25.1-1. Molded Case Type Transfer Switch**

## Dimensions and Weights

Table 25.2-3. Automatic Molded Case Transfer Switches ① (NEMA 1, 3R, 12 ②)—Dimensions and Shipping Weight

Switch Rating Amperes	Switch Type	Enclosure in Inches (mm)			Gutter Space in Inches (mm)		Bolt Patterns in Inches (mm)		Standard Terminals ③			Weight in Lb (kg)
		A Height	B Width	C Depth	D Width	E Depth	G Horizontal	H Vertical	Line	Load	Neutral	
30–100	HFD ④	47.74 (1213.0)	20.81 (528.6)	15.22 (386.6)	8.00 (203.2)	4.00 (101.6)	10.75 (273.0)	46.44 (1180.0)	(1) #14–1/0	(1) #14–1/0	(3) #14–1/0	232 (105)
	HFD ④	35.61 (904.0)	20.06 (509.5)	11.34 (288.0)	8.00 (203.2)	4.00 (101.6)	10.75 (273.0)	34.31 (904.0)	(1) #14–1/0	(1) #14–1/0	(3) #14–1/0	150 (68)
150	HFD ④	47.74 (1213.0)	20.81 (528.6)	15.22 (386.6)	8.00 (203.2)	4.00 (101.6)	10.75 (273.0)	46.44 (1180.0)	(1) #6–300	(1) #6–300	(3) #4–300	232 (105)
150–225	HFD ④	35.61 (904.0)	20.06 (509.5)	11.34 (288.0)	8.00 (203.2)	4.00 (101.6)	10.75 (273.0)	34.31 (904.0)	(1) #6–300	(1) #6–300	(3) #4–300	150 (68)
	HKD ④	48.00 (1219.2)	20.81 (528.6)	16.65 (422.9)	8.00 (203.2)	4.00 (101.6)	11.00 (279.4)	45.50 (1155.7)	(1) 3/0–350	(1) #6–350	(3) #4–350	305 (134)
300	HKD ④	56.00 (1422.4)	20.81 (528.6)	16.65 (422.9)	8.00 (203.2)	4.00 (101.6)	11.00 (279.4)	53.50 (1358.9)	(1) 3/0–350	(1) #6–350	(3) #4–350	295 (134)
400	HKD ④	64.00 (1525.6)	25.81 (655.6)	16.65 (422.9)	8.00 (203.2)	4.00 (101.6)	16.00 (406.4)	61.48 (1561.6)	(2) #1–500	(2) #1–500	(6) 250–500	340 (150)
	HLD ④	64.00 (1525.6)	25.81 (655.6)	16.65 (422.9)	8.00 (203.2)	4.00 (101.6)	16.00 (406.4)	61.48 (1561.6)	(2) 4/0–600	(2) #1–500	(6) 250–350	425 (193)
	HLD ④	53.00 (1346.0)	25.81 (655.6)	16.65 (422.9)	8.00 (203.2)	4.00 (101.6)	16.00 (406.4)	51.50 (1308.0)	(2) 3/0–350	(2) #1–500	(6) 250–350	425 (193)
600	HLD ④	64.00 (1525.6)	25.81 (655.6)	16.65 (422.9)	8.00 (203.2)	4.00 (101.6)	16.00 (406.4)	62.50 (1588.0)	(2) 3/0–350	(2) #1–500	(6) 250–350	475 (214)
	HMDL ④	76.74 (1949.2)	25.81 (655.6)	17.75 (450.8)	8.00 (203.2)	4.00 (101.6)	16.00 (406.4)	75.15 (1908.8)	(2) #1–500	(2) #1–500	(6) 4/0–500	480 (218)
800	HMDL ④	76.74 (1949.2)	25.81 (655.6)	17.75 (450.8)	8.00 (203.2)	4.00 (101.6)	16.00 (406.4)	75.15 (1908.8)	(3) 3/0–400	(3) 3/0–400	(12) 4/0–500	510 (232)
800–1000	HNB ④	76.74 (1949.2)	25.81 (655.6)	17.75 (450.8)	8.00 (203.2)	4.00 (101.6)	16.00 (406.4)	75.15 (1908.8)	(4) 4/0–500	(4) 4/0–500	(12) 4/0–500	570 (259)

① Information provided is for three-pole configurations and subject to change. Alternate lug terminal sizes are available for some configurations—consult with factory. Please reference product outline drawings for the latest detailed information.

② Consult factory for NEMA 4X.

③ Suitable for copper only.

④ Applies to all voltage configurations except three-phase (208/120) and single-phase (240/120 or 208/120).

⑤ Applies to three-phase (240/120 or 208/120) voltage configurations with ATC-100 or ATC-300+ controller only.

⑥ Applies to two-pole, single-phase (240/120 or 208/120) voltage configurations with ATC-300+ controller only.

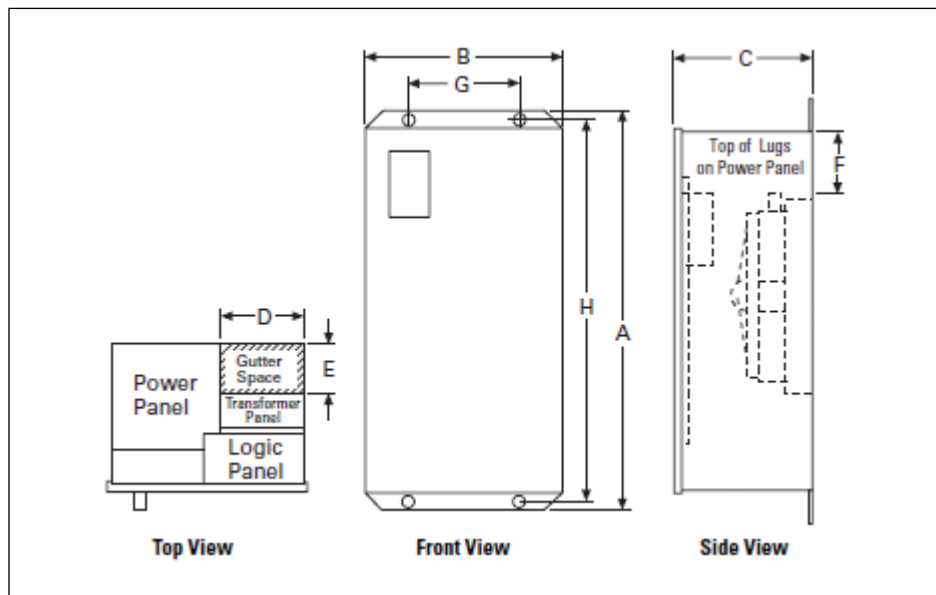



## Usual Environmental Conditions

### Ambient Temperature

- Operation: -20 °C to +40 °C (-4 °F to +104 °F)
- Storage: -30 °C to +80 °C (-22 °F to +176 °F)

### Relative Humidity

- Operation: up to 90% (noncondensing)
- Altitude: Product voltage and current ratings are applicable up to a maximum altitude of 2000 m (6562 ft) above sea level

## Unusual Environmental Conditions

Special attention should be given to applications subject to the following conditions:

### 1. Excessive dust or flyings

It is generally recommended that the transfer switch be installed in a clean, dry room with filtered and/or pressurized clean air. Air filters and gasketing material can be added to ventilated enclosures upon request.

### 2. Excessive moisture

Depending upon conditions, an internal thermostat-controlled heater may be indicated to mitigate condensation. Additionally, stainless-steel enclosure designs are available.

### 3. Excessive altitude

When a transfer switch installation exceeds 2000 m (6562 ft) in altitude, voltage and current ratings are subject to the following derating factors based on ANSI C37.20.1

Table 25.2-4. Altitude Derating

Meters	Feet	Voltage	Current
2000	6562	1.0	1.0
2134	7000	0.989	0.998
2286	7500	0.976	0.995
2438	8000	0.963	0.993
2591	8500	0.950	0.990
2743	9000	0.933	0.987
2896	9500	0.917	0.983
3048	10,000	0.900	0.980
3200	10,500	0.883	0.977
3353	11,000	0.867	0.973
3505	11,500	0.850	0.970
3658	12,000	0.833	0.967
3810	12,500	0.817	0.963
3962	13,000	0.800	0.960

**Note:** Values for intermediate altitudes may be derived by linear interpolation.

### 4. Excessive high or low temperatures

For ambient temperatures exceeding 40 °C, and based on a standard temperature rise of 65 °C, the continuous current rating of the transfer switch is subject to the following thermal derating based on ANSI C37.20.1:

$$I_a = I_r \sqrt{\frac{105^\circ\text{C} - \text{Special Ambient, }^\circ\text{C}}{65^\circ\text{C}}}$$

where:

$I_a$  is the derated continuous current (amperes) at the special ambient temperature

$I_r$  is the rated continuous current (amperes), on the basis of 40 °C ambient temperature

### 5. Damaging or hazardous vapors

For installations in corrosive environments where standard silver-plated bus is subject to “whiskering” in the presence of hydrogen sulfide (e.g., wastewater treatment facilities), tin-plated bus can be provided to mitigate whisker length to a few millimeters.

## Heat Loss

Estimated heat loss of the transfer switch (fixed and drawout mount) is based on operation at 100% of the continuous current rating.

Table 25.2-5. Estimated Heat Loss

Current Rating (Amperes)	Fixed Mount (Watts)
30	20
70	28
100	38
150	30
200	39
225	44
300	54
400	82
600	106
800	174
1000	243

## Transfer Switches



**Automatic Transfer Switch Family**

### General Description

Eaton's low-voltage automatic transfer switch assemblies provide a reliable means of transferring essential load connections between primary and alternate sources of electrical power.

Data centers, hospitals, factories and a wide range of other facility types that require continuous or near continuous uptime typically utilize an emergency (alternate) power source, such as a generator or a backup utility feed, when their normal (primary) power source becomes unavailable.

When the normal power source fails, the transfer switch quickly and safely transitions the load connections to the emergency power source, allowing critical loads to continue running with minimal or no interruption. All electrical power consumed by the circuit, equipment or system connected to the transfer switch output is defined as the load.

A typical transfer sequence includes these steps:

1. The normal utility power source fails.
2. When power from the generator or backup utility feed is stable and within prescribed voltage and frequency tolerances, the transfer switch shifts the load to the emergency power source. Depending on a facility's needs and preferences, the transfer process is self-acting or manually initiated.
3. When utility power is restored, the transfer switch returns the load from the emergency power source to the normal power source. The retransfer process is self-acting or manually initiated.

### Arrangements

#### Two Power Sources

##### Utility—Generator

The standard transfer switch use case includes an electric utility service and an engine-generator set (generator) providing the normal and emergency power sources. This system arrangement is typically referred to as an emergency standby generator system. The single generator shown may be several engine-generator sets operating in parallel.

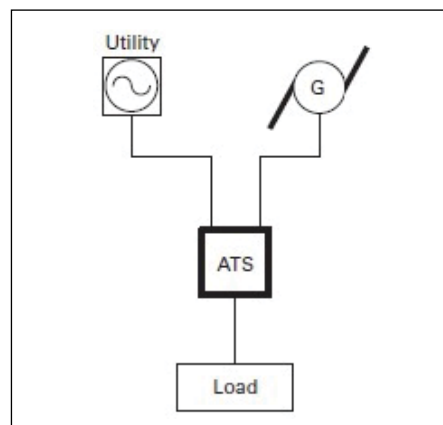
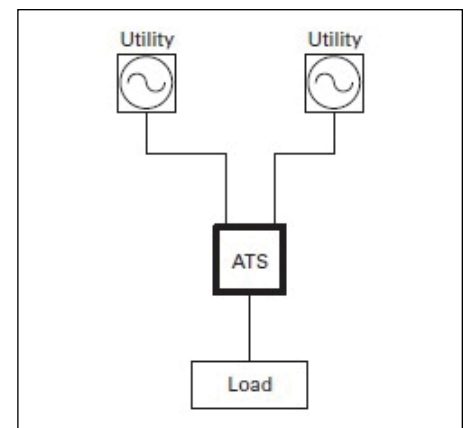

**Figure 25.2-2. Utility—Generator**

##### Utility—Utility

This use case employs two utility sources providing some level of redundancy in the distribution system and allows for quick restoration of service to the load if an upstream equipment failure occurs.

The two sources can be independent of each other, requiring the public utility company to provide dual electric services, or they can originate from a single electric service that is distributed through redundant paths within the facility.



**Figure 25.2-3. Utility—Utility**

##### Generator—Generator

Transfer switches are sometimes applied between two generator sets for prime power use, often at remote installations. In such cases, the generator may be required to provide continuous power 24/7. As a means to equally share run-time, source power is periodically alternated between the generator sets.

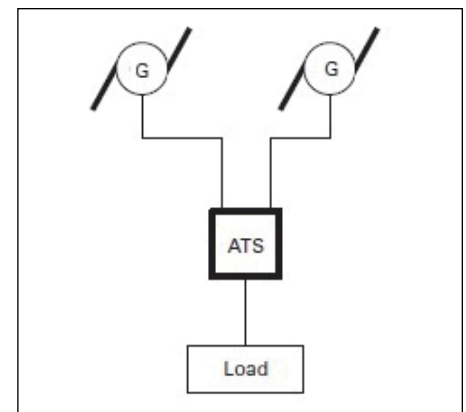

**Figure 25.2-4. Generator—Generator**

### Three Power Sources

#### Utility—Generator—Generator

Critical facilities with an emergency standby generator system will often include provisions for a second generator connection to serve as a redundant emergency backup that can be used during periods of inclement weather or when scheduled maintenance is being performed on the first generator.

In some cases, the first generator is permanently installed on-site whereas the second generator will be a portable roll-up type that is deployed when needed. Two variations of this arrangement are shown. When configured as shown in the first example, the generator start circuits must be managed to prevent unnecessary running when the utility source is available.

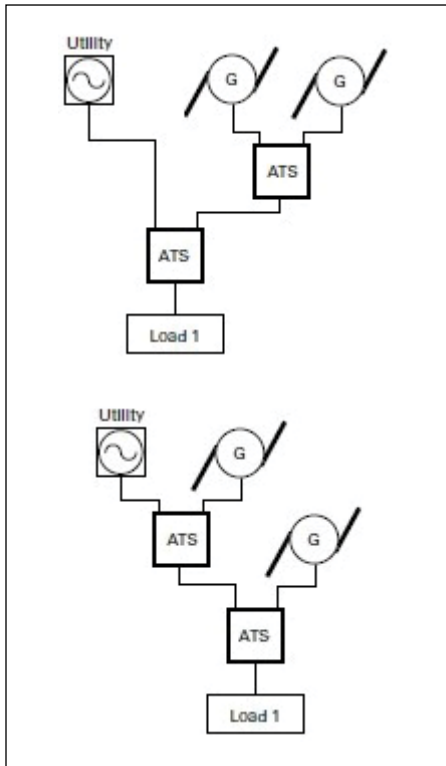

Figure 25.2-5. Utility—Generator—Generator

### Three Power Sources

#### Utility—Utility—Generator

This use case expands on the redundancy provided by dual utility arrangement and includes an emergency standby generator source. The generator can be dedicated for use by a single transfer switch or shared among multiple transfer switches employing a priority control scheme. Two variations of this arrangement are shown.

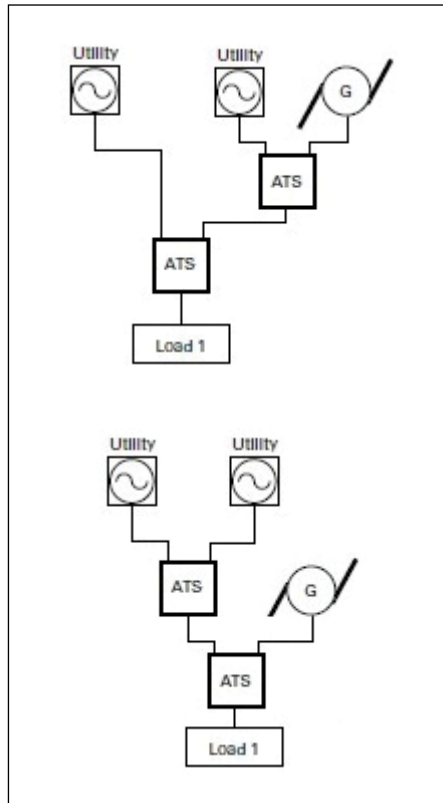

Figure 25.2-6. Utility—Utility—Generator

### Transition Types

Transfer switches can transition loads between normal and emergency power sources in two basic ways: open or closed.

The specific functions performed by a given load and the importance of those functions to safety or security play an important role in determining which kind of transition is required.

### Open Transition

An open transition is a “break before make” transfer. That is, the transfer switch breaks its connection to one power source before making a connection to the other. For some period of time between disconnection and connection, neither the normal power source nor the emergency source is providing electricity to downstream loads. There are two kinds of open transition: open delayed and open in-phase.

#### Open Delayed Transition

For an open delayed transition, the transfer switch pauses in-between disconnecting the load from one power source and connecting it to the other power source. The delay typically lasts either a pre-set amount of time (fixed or programmed time delay) or however long it takes the load voltage to decay below a pre-specified level (programmed threshold). The load voltage decay approach is more precise.

#### Open In-Phase Transition

With open in-phase transition, an automatic controller uses built-in intelligence to execute an open transition at the precise moment it expects the normal and emergency power sources to be synchronized in phase, voltage and frequency.

In-phase transitions are typically completed in 150 milliseconds or less to ensure that inrush current is equal to or less than the normal starting current of any inductive load(s).

If synchronization doesn’t occur within this time span, the transfer switch may have the ability to default automatically to a delayed transition that serves as a failsafe.

### Closed Transition

A closed transition is a “make before break” transfer, in that the transfer switch makes a connection to a second power source before breaking its connection with the first power source. As there’s no gap between disconnection and connection, downstream loads receive continuous power throughout the transfer process.

Switches configured for closed transition transfer power automatically as soon as both power sources are closely synchronized in phase, voltage and frequency. The overlap period during which both sources are simultaneously connected, or “paralleled,” usually lasts no more than 100 milliseconds to comply with local utility interconnect requirements.

## Modes of Operation

Power transfers involve two processes: initiation and operation. Initiation is what starts the transfer. Operation is what completes it. Most transfer switches can support multiple operation modes through the addition of configurable options.

### Manual Mode

In manual mode, both initiation and operation are performed manually, typically by pushing a button or moving a handle. Initiation occurs locally.

### Non-Automatic Mode

In non-automatic mode, the operator manually initiates a transfer by pressing a button or rotating a switch that causes an internal electromechanical device to electrically operate the switching mechanism. Initiation can occur locally or remotely.

### Automatic Mode

In automatic mode, the transfer switch controller is self-acting and completely manages both initiation and operation. Initiation is triggered when the automatic controller senses an unavailability or loss of source power followed by operation of the switching mechanism.

## Switching Mechanism

The switching mechanism is the part of a transfer switch that is physically responsible for carrying the rated electrical current and shifting the load connection from one power source to another.

Low-voltage switching mechanism technology comes in two basic varieties, commonly referred to as “contactor type” and “circuit breaker type”. Circuit breaker switching mechanisms can be further divided into two sub-types: molded case and power frame.

## Contactor Type

This is the most common and typically most economical switching mechanism type. Contactors are constructed as an electrically controlled, double-throw switch where a single operator opens one set of power contacts while closing a second set. In an open transition design, a mechanical interlock is often employed to prevent simultaneous closure of both contact sets. In a closed transition design, the mechanical interlock is absent. Unlike a circuit breaker, a contactor is not designed to provide overcurrent protection or interrupt short-circuit fault current.

Contactor switching mechanisms are fast and flexible, but do not offer overcurrent protection.



*Contactor switching mechanisms*

## Molded Case Type

Routinely used for closing and interrupting a circuit between separable contacts under both normal and abnormal conditions, molded case switches feature simple designs and are capable of supporting either a mechanically operated, over-center toggle or a motor operator. They are typically assembled in an enclosed housing constructed of insulating material.

When configured for use in a transfer switch, a pair of molded case switches are operated via a common, interlocking mechanical linkage. The linkage can be driven manually or automatically. When overcurrent protection is needed, molded case circuit breakers equipped with a thermal-magnetic or electronic trip element are used.

Molded case switching mechanisms provide a compact, cost-effective and service entrance-rated solution, as they eliminate the need for additional upstream protective devices. Each molded case mechanism individually complies with industry standard UL 489, which covers low-voltage molded case switches and circuit breakers.

Molded case switching mechanisms are ideal for applications that require integral overcurrent protection.



*Molded case switching mechanisms*



### Power Frame Type

Power frame switches are larger, faster and more powerful than molded case switches and are capable of handling up to 5000 A.

A two-step stored energy technology is utilized, which permits manual and electrical operation under load.

When an application requires integral overcurrent protection, power circuit breakers are configured with an electronic trip unit that facilitates selective coordination.

Power frame switching mechanisms are a good fit for applications vulnerable to large fault currents.

Each power frame switch or circuit breaker individually complies with industry standard UL 1066, which covers low-voltage power circuit breakers.

**Note:** For more detail, reference Eaton Publication WP140001EN.



**Power Frame Switching Mechanisms are Available up to 5000 A and Utilize Stored Energy Technology**

### Mounting

#### Drawout

The use of drawout construction permits the switching mechanism to be levered into three different positions (connected, disconnected, withdrawn) within a cassette or cell structure facilitating safety, testing and serviceability. Drawout is typically achieved using rail slides or rollers.

When in the disconnected position, the switching mechanism is isolated from the main power bus or cabling. Some designs may allow the switching mechanism to be manually or electrically (via control power) exercised to satisfy preventive maintenance requirements. Placing the switching mechanism in the disconnected position can also be used during a lockout/tagout procedure.

Removing the switching mechanism from the transfer switch allows for bench testing or replacement.

Drawout construction is often employed in bypass isolation type transfer switches used in mission-critical applications.



**Drawout Mounting**

#### Fixed

Switching mechanisms with a fixed mounting configuration are simple and economical because there are no drawout system components.

The switching mechanism bolts directly to the main power bus or cable conductors and may result in a reduced enclosure depth when compared to drawout.

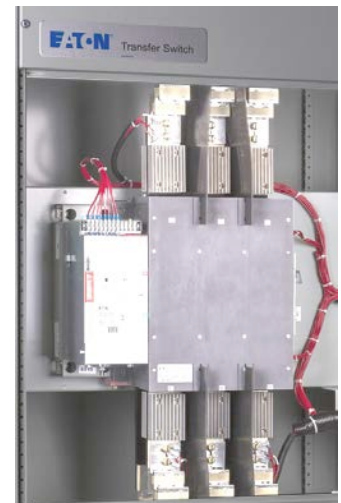

**Fixed Mounting**

### Power Poles

Every transfer switch includes a specific number of power poles. Two- and three-pole designs are commonly employed in locations fed by single-phase power whereas three- and four-pole designs are utilized in places supplied with three-phase power.

Each power pole is constructed with two sets of main contacts (momentary and stationary components) that are interconnected to form a three-terminal, single-pole switch. This arrangement allows the load terminal to be connected with one or both power source terminals.

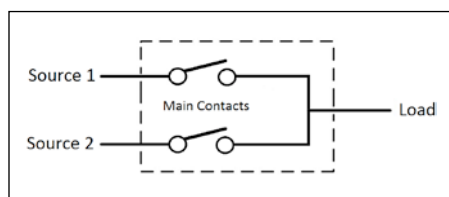

**Figure 25.2-7. Power Pole**

Power poles are used to switch individual phase conductors of the power source and where required, the neutral conductor.

When multiple power poles are combined with an operator device(s), a switching mechanism is formed.

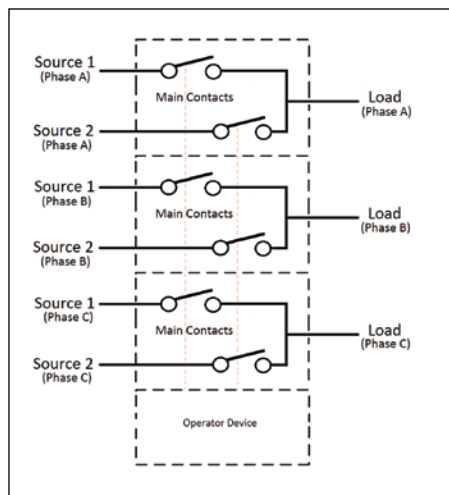

**Figure 25.2-8. Switching Mechanism**

For simplicity, multiple power poles are eliminated from the common transfer switch symbol used in one-line drawings.

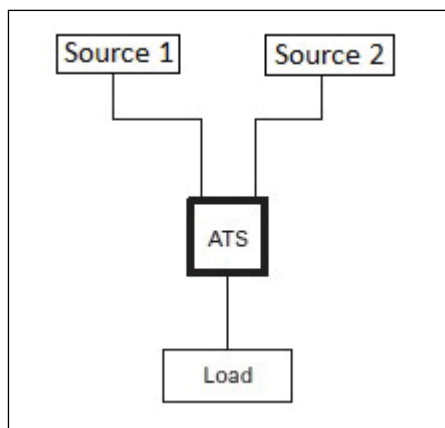

**Figure 25.2-9. Transfer Switch Schematic Drawing**

In open transition transfer switches, the main contacts are mechanically interlocked, preventing both sets from being closed at the same time. This action prevents the inadvertent electrical paralleling of the two power sources that can differ in voltage, frequency and phase.

Closed transition designs do not include a mechanical interlock and will permit simultaneous paralleling of the power sources when they are electrically synchronized, however, an electrical interlock is used to limit the paralleling time (typically 100 ms) to comply with public utility interconnect specifications.

Power poles also include features to mitigate arcing and erosion of the main contacts such as arcing contacts, arc runners and arc chutes.

### Arc Chutes

Switching mechanisms include arc chutes, housed within an arc chamber constructed of high-dielectric high-strength material, that are mounted over each set of main contacts. Arc chutes are constructed of metal plates designed to extinguish an electrical arc and protect the main contacts.



**Arc Chutes**

### Operator Device

The operator device drives the power pole main contacts open or closed. Depending on the switching mechanism type, this is accomplished using an electric solenoid, electric motor or a spring stored energy mechanism.

Some operator device designs allow the source 1 main contacts to be driven independently of the source 2 main contacts. This permits the load to remain disconnected from either of the power sources for a programmed time delay or until the residual load voltage decays below a programmed threshold. When the load is disconnected in this manner, the transfer switch is said to be in a center-off or "neutral-position".

Contact type switching mechanisms that provide a "neutral-position" are referred to as 3-position, otherwise, they are termed 2-position. All molded case and power frame type switching mechanisms provide a "neutral-position".

Applications (e.g., inductive loads) specifying open-delayed transition will require a transfer switch with a "neutral-position".

### Switched Neutral

For three-phase power applications requiring that the neutral conductor be switched, transfer switches can be configured with a fully rated fourth pole that performs identical to the individual phase (A, B, C) power poles. For single-phase applications, a fully rated third pole can be configured.

A switched neutral is commonly used when the transfer switch is fed by separately derived power sources. The benefits of using a switched neutral include the following:

- Inhibits circulating ground current from flowing between power sources on the neutral conductor that can cause nuisance tripping of the ground fault relay at the de-energized or unconnected source
- Prevents de-sensitizing the ground fault relay at the energized or connected source
- Eliminates the need for complex ground fault sense wiring

**Note:** For more detail, reference Eaton White Paper IA08700002E.

For closed transition transfer switches, the switched neutral pole operates as “make-before-break” and simultaneous closure or overlapping of the neutral contacts is limited to 100 ms.

For open transition transfer switches, the switched neutral pole operates in a “break-before-make” fashion and eliminates potential problems that can occur with a three-pole solid neutral or three-pole overlapping neutral (not offered by Eaton) configuration.

The likelihood of a ground fault occurring during the time period that neutral contacts are simultaneously closed or overlapped is just as likely as any other time but perhaps slightly more. When transferring between power sources, dynamic changes are introduced into the system such as moving contacts, vibration and energizing previously de-energized conductors that may push and pull equipment and cables in different directions.

Configuration	Advantages	Disadvantages
Three-pole	Lower cost	Nuisance tripping of ground fault (GF) relay on de-energized or unconnected source. De-sensitizing the ground fault relay at the energized or connected source. Added complexity to implement ground fault relay circuit to prevent nuisance tripping of ground fault relay at de-energized or unconnected source.
Four-pole (switched neutral)	No circulating ground current (eliminates nuisance tripping of ground fault relay at de-energized or unconnected source and desensitizing ground fault relay at energized or connected source).	Higher cost
Three-pole (overlapping neutral)	May be less expensive than four-pole if overlapping neutral is not fully rated.	During the time when both neutrals are connected, the same disadvantages as a three-pole switch exists.

### Bypass Isolation Automatic Transfer Switches

For simplified maintenance and improved uptime, bypass isolation automatic transfer switches provide dual switching functionality and redundancy for critical applications. The primary switching mechanism (automatic transfer switch) handles the day-to-day distribution of electrical power to the load, while the secondary switching mechanism (bypass switch) serves as a backup or redundant device. During repair or maintenance procedures, service personnel can bypass power around the automatic transfer switch through the bypass to ensure that critical loads remain powered without interruption.

In some bypass isolation transfer switch designs, the bypass switch is fully automatic and self-acting, providing increased redundancy. When in the automatic bypass mode of operation, the control logic continues to monitor the normal power source and will automatically initiate a transfer to the alternate source should the normal source fail.

A bypass isolation transfer switch is frequently selected for use in healthcare, as well as in other critical applications, because it allows the automatic transfer switch (ATS), and in some cases the bypass switch, to be drawn out and isolated from the power source(s) to facilitate regular maintenance, inspection and testing as prescribed by code (NFPA 110).

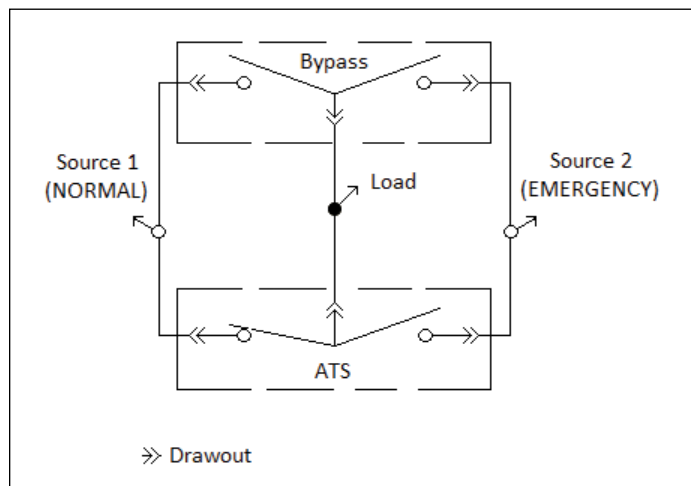
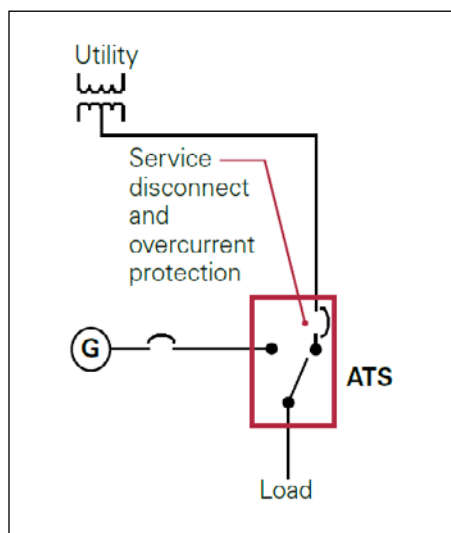

Figure 25.2-10. Bypass Isolation ATS Schematic Drawing

### Service Entrance Transfer Switches

Facilities with a single utility connection and a single emergency power source will often have an automatic transfer switch located at the service entrance to ensure that critical loads can quickly and safely shift to emergency power (generator) if utility power is interrupted. Non-critical loads are often inhibited or shed from connection to the emergency power source to avoid capacity overload.

Service entrance rated transfer switches include integral overcurrent protection and a disconnect means allowing them to be installed directly at the point of service entrance, which eliminates the need for separate upstream device(s), including additional power connections. As required, they can also include ground fault protection.



**Figure 25.2-11. Service Entrance Transfer Switch with Integral Overcurrent Protection Saves Space and Cost**

### Arc Flash Reduction

When required by the National Electrical Code (NEC), integral overcurrent protection can be configured with technology to reduce clearing time, such as an Arcflash Reduction Maintenance System (ARMS), resulting in lower incident energy at all downstream work locations.

A circuit breaker equipped with ARMS can improve worker safety by providing a simple and reliable method to reduce fault clearing time. For applications where the highest continuous current trip setting of the overcurrent device in a circuit breaker is rated (or can be adjusted to) 1200 A or higher, a method to reduce clearing time is required per NEC 240.87.

When the ARMS maintenance mode is enabled, an integral analog trip circuit provides an accelerated instantaneous trip. To facilitate maximum arc flash reduction while avoiding nuisance tripping, the ARMS pickup level is adjustable.

Service entrance transfer switch construction can vary in the marketplace and care should be taken by the consulting engineer to consider when the transfer equipment needs to be “fully UL 1008 Listed” and marked for use at 100% of rated current.

The phrase “fully UL 1008 listed” is used to describe the entire transfer switch enclosure assembly—including the integral circuit breaker and power bus—which has passed rigorous temperature rise performance testing required by the UL 1008 standard for transfer switch equipment.

**Table 25.2-6. Example Incident Energy Level Decreases with ARMS**

Service Entrance Transfer Switch Rating (A)	Available Fault Current (kA)	Arcing Fault Current (kA)	Without ARMS		With ARMS	
			Maximum Clearing Time (sec)	Incident Energy (cal/cm <sup>2</sup> )	Maximum Clearing Time (sec)	Incident Energy (cal/cm <sup>2</sup> )
4000	64	32	0.5	58.4	0.04	4.7
3000	51	26.4	0.5	47.3	0.04	3.8
2000	39	21	0.5	37	0.04	3.0
1600	28	15.8	0.5	27.2	0.04	2.2
1200	19	11.3	0.5	19	0.04	1.5

**Note:** Overcurrent protection device modeled is Eaton Magnum DS circuit breaker (520MC or 1150+ trip). When Eaton MCCB (310+ trip) is used as the protection device, maximum clearing time (ARMS) is 0.03 sec. Arcing fault current and incident energy values derived using SKM System Analysis software Incident energy is calculated immediately downstream of transfer switch load.



## UL 1008 Standard

The industry safety standard governing the construction and performance criteria for transfer switch equipment, having a maximum voltage rating of 1000V, is UL 1008.

To ensure a minimum level of reliability, the standard requires that all transfer switch equipment, listed to apply the UL 1008 mark, meet rigorous performance testing—regardless of the design type.

### Performance Tests

#### Undervoltage

A voltage sensing relay coil shall be capable of withstanding 95% of rated pull-in voltage without damage.

#### Overvoltage

An electromagnet coil shall be capable of withstanding 110% of rated voltage without damage.

#### Overload

The transfer switch must operate for a number of operation cycles, with a non-unity power factor, at a multiple of its rated current.

#### Dielectric

The transfer switch shall be capable of withstanding 1000 Vac, plus twice its maximum rated voltage, without breakdown.

#### Temperature Rise

While operating at 100% of its rated current, the transfer switch temperature shall not exceed a maximum value, sustain material damage or pose a fire risk.

#### Endurance

The transfer switch must operate for thousands of operation cycles without fail.

### Withstand and Closing

With the transfer switch closed into a test circuit, it must “withstand” a short-circuit current, at a specific voltage, for a specified time period or until a specific overcurrent protective device opens. The same transfer switch sample must then “close-into” a test circuit, with a short-circuit current applied, for a specified time period or until a specific overcurrent protective device opens. At the conclusion of each test, a set of operational, physical and electrical criteria must be met.

An optional short-time variant of the test can be performed at the request of the manufacturer but is not required to obtain a UL 1008 mark.

### Withstand Closing Current Ratings

When applying a transfer switch for use in a power distribution system, consideration must be given to the withstand closing current rating (WCR) to ensure system integrity and reliability.

The UL 1008 standard permits transfer switches to be marked with one or more short-circuit and/or short-time WCRs specific to an overcurrent protection (OCP) device type. Transfer switches with multiple ratings provide greater application flexibility.

The WCR represents a transfer switch's capability to ride-out a fault condition until the overcurrent protective device (a circuit breaker or fuse that is integral to the transfer switch assembly or is located externally upstream) opens and clears the fault. The WCR, applicable up to a maximum voltage, is given in thousands of amperes and must be equal to or greater than the available fault current calculated at the location of the transfer switch in the electrical circuit. In some instances, a WCR may be further qualified by a maximum time duration.

### Short-Circuit Withstand Closing Rating

Applied in electrical circuits where the overcurrent protection (OCP) device, a fuse or circuit breaker, is equipped with an instantaneous trip response capable of clearing a fault quickly without intentional delay.

Various transfer switch short-circuit WCR examples are as follows:

- When the overcurrent protection device is an external circuit breaker, of **any** type, a “time-based” short-circuit WCR can be applied. An important caveat is that the maximum clearing time of the circuit breaker's instantaneous trip response must be equal to or less than the maximum time duration of the marked short-circuit WCR.
- When the overcurrent protection device is an external circuit breaker, of a **specific** type that appears on a manufacturer's list, a “specific circuit breaker” short-circuit WCR can be applied and offers a higher current rating compared to a time-based rating.
- When the overcurrent protection device is a fuse, of a **specific** type or classification, a “fuse” short-circuit WCR can be applied and offers the highest current rating.
- When the overcurrent protection (OCP) device is integral to the transfer switch assembly, an “integral OCP” short-circuit WCR can be applied. A typical use is a service entrance transfer switch that is fed directly from the utility.

A transfer switch short-circuit withstand closing current rating (WCR) is frequently utilized in circuits where the overcurrent protective device is a UL 489 circuit breaker. A common example is a molded case circuit breaker installed in UL 891 switchboard, serving as a feeder to a transfer switch.



When applying a transfer switch short-circuit WCR, it's important to note that UL 489 Listed circuit breakers include a magnetic, built-in instantaneous override that can't be defeated or disabled. For molded case breakers, the override is fixed at approximately 10–12 times the nominal trip or frame rating. For insulated case breakers, the override is fixed at approximately 13–18 times the nominal trip or frame rating.

For many years, fuses and thermal-magnetic circuit breakers (UL 489) have successfully been used to provide overcurrent protection for short-circuit rated transfer switches. Today, circuit breakers are more commonly configured with an electronic trip unit having a short-time element (LS, LSI, LSG, LSIG), allowing the short-time pick-up/delay to be adjusted.

When a circuit breaker's short-time element adjustments are set to maximum, the protection provided can be similar to that of a fuse or thermal-magnetic circuit breaker. However, adjusting the settings to something less than maximum can provide shorter clearing times and increased protection at lower level faults when compared to a fuse (Figure 25.2-12) or a thermal-magnetic circuit breaker. As a result, UL 489 breakers equipped with a short-time element have the ability to provide "better protection" compared to a fuse or a circuit breaker without a short-time element.

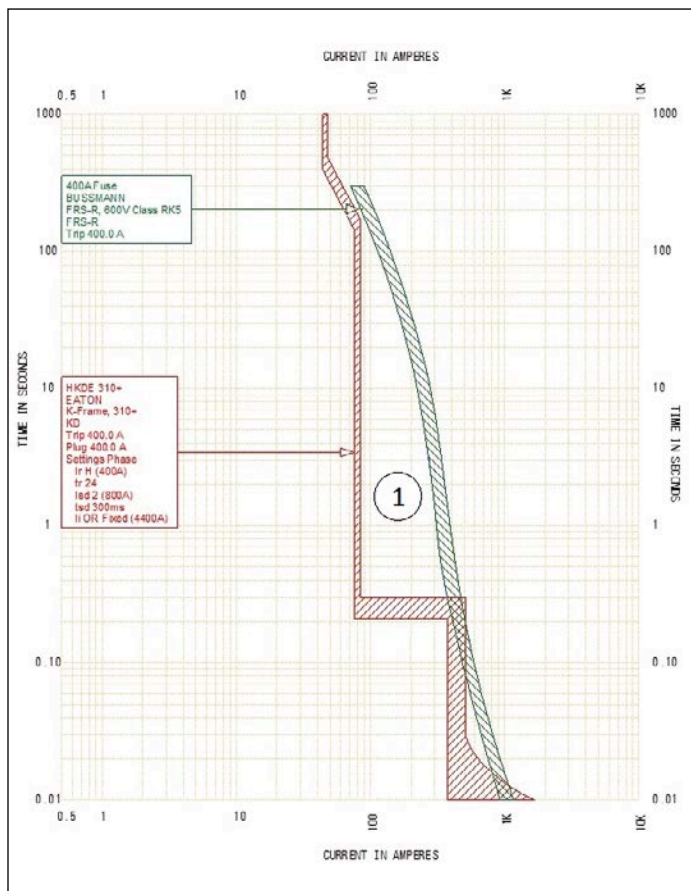

Figure 25.2-12. Time-current characteristic curve showing that a UL 489 circuit breaker with LSI trip (red curve) can clear the same level of fault current more quickly (region 1) than a fuse (green curve)

### Short-Time Withstand Closing Rating

Typically applied in critical electrical circuits where the overcurrent protection device is a circuit breaker, equipped with an adjustable electronic trip capable of providing intentional delay, that allows for selective coordination within the distribution system. In many cases, the instantaneous response of the circuit breaker is disabled.

When a transfer switch carries an optional short-time WCR, it will always be qualified by a maximum time duration. Values typically range between 0.1 and 0.5 seconds correlating with a circuit breaker's short-time response. To ensure proper protection, the circuit breaker short-time settings must be coordinated with the maximum time duration of the marked short-time WCR.

Short-time WCRs are frequently utilized in circuits where the overcurrent protective device is a UL 1066 circuit breaker, such as UL 1558 switchgear.

Transfer switches with a short-time WCR and maximum time duration of 0.5 seconds offer the greatest flexibility to the specifying engineer when designing a selectively coordinated system.

### Life Expectancy

Transfer switches are periodically exercised upon a loss of normal power or when conducting routine testing. Many designs include control logic with a plant exerciser capable of initiating a test automatically based on a programmed schedule (weekly, biweekly, monthly).

Assuming a transfer switch is exercised once a week through scheduled testing or a power outage condition, an approximation of life expectancy can be made based on UL 1008 endurance test criteria that is conducted with and without rated current.

Table 25.2-7. UL 1008 Endurance Testing

Transfer Switch Rating (Amperes)	Number of Operation Cycles		Total
	With Current	Without Current	
0–300	6000	—	6000
301–400	4000	—	4000
401–800	2000	1000	3000
801–1600	1500	1500	3000
1601 and above	1000	2000	3000

Table 25.2-8. Estimated Transfer Switch Life Expectancy

Transfer Switch Rating (Amperes)	52 Transfer/Retransfer Operations per Year		
	With Current (Years)	Without Current (Years)	Total (Years)
0–300	115	—	115
301–400	76	—	76
401–800	38	19	57
801–1600	28.5	28.5	57
1601 and above	19	38	57

## **NFPA 70 System Installation Types**

Transfer switches are employed in a variety of special conditions that typically fall into one of four categories defined by the National Electrical Code (NFPA 70): emergency systems, legally required systems, critical operations power systems and optional standby systems.

### **Emergency systems**

Emergency systems supply, automatically distribute and control electricity used by systems essential to life safety during fires and other disasters. They include fire detectors, alarms, emergency lights, elevators, fire pumps, public safety communication systems and ventilation systems, and are commonly found in hotels, theaters, sports arenas and hospitals.

Emergency systems are regulated by a municipal, state, federal or other government agency. Transfer from the normal power source to the emergency source must complete within 10 seconds and meet the requirements of Article 700 of the National Electrical Code (NFPA 70). In addition, overcurrent devices must be selectively coordinated with all supply-side overcurrent protective devices.

### **Legally Required Systems**

Legally required systems automatically supply power to a selected set of regulated loads not classified as emergency systems when normal power is unavailable. They serve critical heating, refrigeration, communication, ventilation, smoke removal, sewage disposal and lighting functions that could create hazards or hamper rescue or fire-fighting operations if denied electrical power.

As with emergency systems, legally required systems are regulated by municipal, state, federal and other governmental agencies. Transfer from the normal power source to the emergency source must complete within 60 seconds and meet the requirements of Article 701 of the National Electrical Code (NFPA 70). Overcurrent devices must be selectively coordinated with all supply-side overcurrent protective devices.

### **Critical Operations Power Systems (COPS)**

COPS supply, distribute and control electricity in designated critical areas when a normal power source fails. They include HVAC, fire alarm, security, communication, signaling and other services in facilities that a government agency has deemed important to national security, the economy or public health and safety.

All COPS must meet the requirements of Article 708 of the National Electrical Code (NFPA 70), and their overcurrent devices must be selectively coordinated with all supply-side overcurrent protective devices.

### **Optional Standby Systems**

Optional standby systems supply power to loads with no direct bearing on health or life safety and are not required to function automatically during power failures. They are typically found in commercial buildings, farms and even residences, and must meet the requirements of Article 702 of the National Electrical Code (NFPA 70).

### **Special Occupancies**

In addition to the special conditions previously discussed, transfer switches are utilized in the critical, life safety and equipment branches of an essential electrical system located within a healthcare facility and subject to Article 517 of the National Electrical Code (NFPA 70).

### **Other Standards**

Other relevant industry standards for transfer switches are NFPA 99 (Health Care Facilities Code) and NFPA 110 (Emergency and Standby Power Systems).

**Eaton**  
1000 Eaton Boulevard  
Cleveland, OH 44122  
United States  
Eaton.com

© 2020 Eaton  
All Rights Reserved  
Printed in USA  
Publication No. DG140002EN / Z23483  
February 2020