

Low-voltage power distribution and control systems > Switchgear >

Arc Quenching Magnum DS low-voltage switchgear

Contents

General Description	20.5-2
Arc Quenching Switchgear	20.5-2
Layouts and Dimensions	20.5-5
AQD Location	20.5-5
EAFR Location	20.5-14
Sample Layouts	20.5-17



EATON

Powering Business Worldwide



More about this product
[Eaton.com/lva](https://www.eaton.com/lva)



Complete library of design guides
[Eaton.com/designguides](https://www.eaton.com/designguides)

Arc Quenching Switchgear



Arc Quenching Switchgear

Product Description

When the Arc Quenching Device (AQD) receives a trigger signal from the Eaton Arc Flash Relay, it produces a lower impedance arc in a controlled micro-environment within the arc containment vessels located in the AQD. The lower impedance arc collapses the voltage and immediately extinguishes the unintended arcing fault as the current begins to flow into the AQD. This quenching operation occurs in less than 4 ms. The arcing continues safely contained inside the AQD until the upstream power circuit breaker trips. See white paper “Current limiting arc flash quenching system for improved incident energy reduction,” WP019003EN.pdf, for more information.

Arc Quenching Switchgear is available in various enclosure constructions to meet specific application requirements. Please see the following design guides for additional information.

Application Description

The Arc Quenching Device (AQD) can be located on the line- or the load-side of the main low-voltage circuit breaker in an Arc Quenching Switchgear (AQS) lineup. With the switchgear energized and the Arc Quenching System active, the entire AQS lineup will be C37.20.7 arc-resistant regardless of the location of the AQD. However, the incident energy of the lineup is affected by the location of the AQD.

Load-side Application

The standard AQS application includes the AQD mounted on the load-side of the low-voltage main circuit breaker. See Figure 20.5-1.

In this application, the lineup will carry two different incident energy levels while the Arc Quenching System is active (indicated by the illumination of the white light above the AQD). The incident energy on the line side of the low-voltage main breaker will be determined by the clearing time of the upstream overcurrent protective device. The incident energy on the load-side of the low-voltage main breaker will be determined by the arc quenching time of the Arc Quenching System. Typically, the load-side incident energy in this application will be less than 1.2 cal/cm². See Figure 20.5-2.

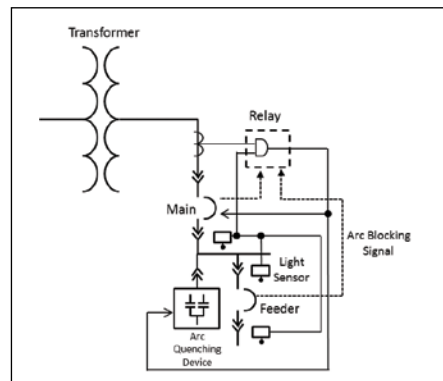

Figure 20.5-1. AQD Load-Side Application

If the Arc Quenching System is inactive (either due to a malfunction, loss of control power, disconnection of the AQD, or if the upstream LV main device is open), the white indicator light above the AQD will cease to be lit. In this case, the incident energy on the line-side of the main low-voltage breaker will remain the same (as determined by the clearing time of the upstream overcurrent protective device). Furthermore, when the main breaker is closed with the AQS inactive, the incident energy on the load-side of the low-voltage breaker will be determined by the total clearing time of the Eaton Arc Flash Relay (EAFR) tripping the low-voltage main breaker. If the main breaker is open and the Arc Quenching System is healthy, the white light will flash indicating the switchgear will be protected by the Arc Quenching System when the main breaker is closed.

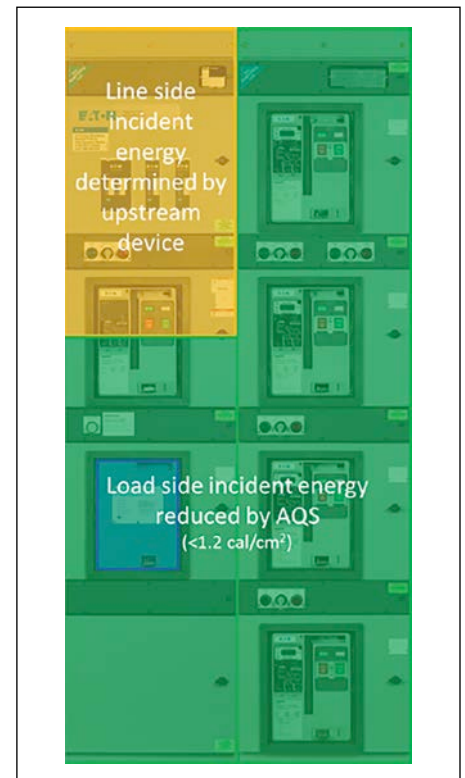

Figure 20.5-2. Standard Application Incident Energy

WARNING

EATON SHOCK & ARC FLASH HAZARD
 Location: SWGR-A
 Report #: TGS123456 Rev. 0 Issued: DEC-2017

LINE SIDE OF MAIN	13' 2"	ARC FLASH BOUNDARY
	31 cal/cm ²	CALCULATED INCIDENT ENERGY AT 1' 6" WORKING DISTANCE
		Incident Energy with Arc Quenching System DISABLED: 31 cal/cm ² at 1' 6" WORKING DISTANCE
LOAD SIDE OF MAIN	6"	ARC FLASH BOUNDARY
	0.8 cal/cm ²	CALCULATED INCIDENT ENERGY AT 1' 6" WORKING DISTANCE
		Incident Energy with Arc Quenching System DISABLED: 3.5 cal/cm ² at 1' 6" WORKING DISTANCE
	480 V Shock Hazard	Limited Approach Boundary: 3' - 6"
	Min. Glove Class: 00	Restricted Approach Boundary: 1' - 0"

AQD Load-side Application Example

AQD Line-Side Application

The substation AQS application includes the AQD mounted on the line-side of the low-voltage main circuit breaker, and must include a wired trip signal from the EAFR to the upstream medium-voltage circuit breaker with a verified clearing time of less than 100 ms. See **Figure 20.5-3**. It is not possible to shunt-trip an upstream medium-voltage switch unless the switch is rated to interrupt full available fault current within 100 ms or less.

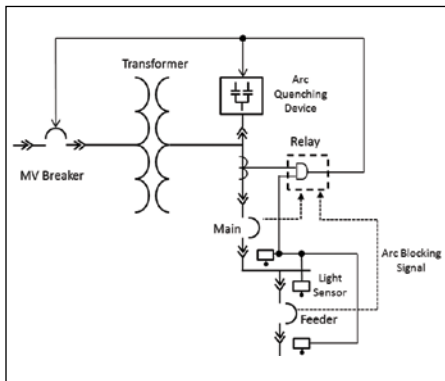

Figure 20.5-3. AQD Line-Side Application

In this application, the entire low-voltage switchgear lineup will carry a single incident energy level while the Arc Quenching System is active (indicated by the illumination of the white light above the AQD). The incident energy of the entire lineup, including the line-side of the low-voltage main breaker, will be determined by the arc quenching time of the Arc Quenching System. Typically, the incident energy of the entire low-voltage switchgear lineup in this application will be less than 1.2 cal/cm². See **Figure 20.5-4**.

If the Arc Quenching System is inactive (either due to a malfunction, loss of control power, or disconnection of the AQD), the white indicator light above the AQD will cease to be lit. In this case, the incident energy of the entire low-voltage switchgear lineup (on the line-side and load-side of the low-voltage main breaker) will be determined by the total clearing time of the Eaton EAFR tripping the upstream medium-voltage breaker.



Figure 20.5-4. Substation Application Incident Energy

Notes for Line- and Load-Side Applications

After switchgear installation, it is highly recommended to perform an arc flash study and label the switchgear with the calculated incident energy.

The Arc Quenching System is electrically interlocked with the main breaker to prevent closing the main if the health contact of either the EAFR or AQD is open, either because the device is still powering up or if there is an error.

The Arc Quenching System requires approximately 30 seconds of boot time on power-up. For applications in which the primary bus could become energized with the main breaker of the protected switchgear closed, an external control power source is recommended. Alternatively, a UPS internal to the switchgear can be specified to ensure that the Arc Quenching System is operational prior to energizing the switchgear primary bus. This will provide protection in the unlikely event that an arc occurs in the switchgear while energizing.

EAFR Zone of Protection

The zone of protection provided by the EAFR is determined by the placement of the arc light point sensors and the placement of CTs. When an arc fault is detected, the EAFR sends a trip signal to the upstream overcurrent protective device and a trigger signal to the Arc Quenching Device. The EAFR must receive both a light signal above the point sensor threshold from any point sensor inside the switchgear and a current input above the pickup setting on the EAFR from the CTs in order to activate the AQD and send a trip signal to the upstream overcurrent protective device.

The arc light point sensors are placed throughout the switchgear in tested and validated locations and are proven to be able to detect the light from an arcing fault anywhere in the Arc Quenching Switchgear (see white paper WP019004EN for more information). However, the location of the CTs is not fixed and could vary depending on how the incoming section is configured for a particular lineup of switchgear (e.g., cable incoming, bus incoming, close-coupled to a transformer, etc. could all affect where the CTs can be placed).

If an arcing fault were to occur inside the Arc Quenching Switchgear enclosure but upstream of the CTs, it would not be detected by the EAFR and therefore the Arc Quenching System would not operate to quench the fault. **As a result, it is recommended that the CTs be placed as far upstream as possible to maximize the zone of protection provided by the EAFR.** Proper placement of the CTs should be considered during the design phase of the power distribution system as it may affect the configuration of the equipment being purchased. For example, for Arc Quenching Switchgear that will be close-coupled to a transformer, the ideal placement of the CTs may be on the secondary bushings of the transformer, outside of the switchgear enclosure. Such a design would ensure that the zone of protection provided by the EAFR fully encompasses the incoming compartment. Consult the factory or an Eaton sales engineer for other CT configurations for the incoming section.

Note: These zone-of-protection considerations are not unique to Arc Quenching Switchgear. Any system that provides protection based on input from a current transformer (such as standard arc flash detection systems or bus differential relays) requires the same design considerations.

General Description

Ratings

- Short-circuit withstand rating up to 100 kA at 635 Vac
- Standard AQD short time withstand rating of 100 ms at 85 kA or 100 ms at 100 kA; Option available for 500 ms at 85 kA
- <4 ms arc quenching time
- >25% reduction in peak fault current
- >44% reduction in peak system stress
- Complete system self-supervision with health status communicated via Modbus and dry contacts
- Available in rear access and front access switchgear configurations
- Anti-nuisance trip technology

Enclosure Configurations

Arc Quenching Switchgear is available in various enclosure constructions to meet specific application requirements:

Traditional Arc-Resistant Construction

- Active arc-resistant protection and incident energy reduction under normal operating conditions
- Traditional passive arc-resistant protection if the AQD is removed and arc-resistant breaker cell provisional cover installed

NEMA 1 Construction

- Active arc-resistant protection and incident energy reduction without the need for ducts, plenums or special enclosure construction
- Reduced installation costs and reduced overhead clearance requirements compared to traditional arc-resistant switchgear

NEMA 3R Construction

- Industry-exclusive NEMA 3R arc-resistant protection
- Arc-resistant protection and incident energy reduction for outdoor switchgear

Standards and Certifications

- Tested to ANSI/IEEE C37.20.7, Type 2B test guide in NEMA 1 construction
- AQD is a UL recognized component per UL 2748
- Arc Quenching Switchgear designed to UL 1558, ANSI C37.20.1, CSA C22.2 No. 31-10, and C37.51

AQD Location

The location of the Arc Quenching Device (AQD) and the Eaton Arc Flash Relays (EAFR) is critical for proper design of a lineup of Arc Quenching Switchgear (AQS). Providing adequate instrument compartment space for the required AQS components must also be considered in the design.

The AQD is installed in a specialized Magnum cassette that typically will be located in the same structure as the low-voltage main breaker. Typically, the AQD will be installed in the cell directly above or below the main breaker.

See **Figure 20.5-5** through **Figure 20.5-13** for valid Arc Quenching Device and circuit breaker arrangements.

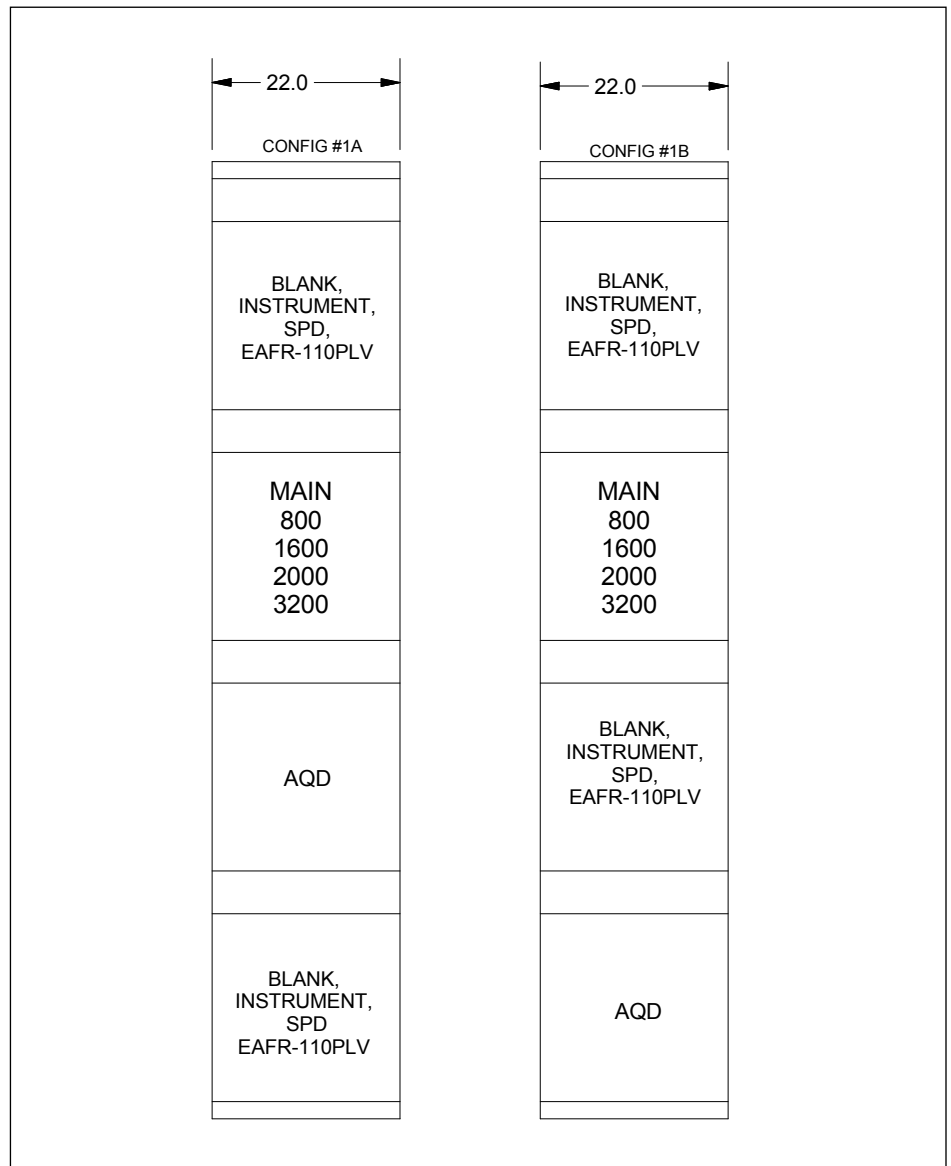

Figure 20.5-5. Breaker Arrangements—Mains (22 W and 30 W)

Note: Feeder in the same structure as the main not recommended due to service entrance requirements.

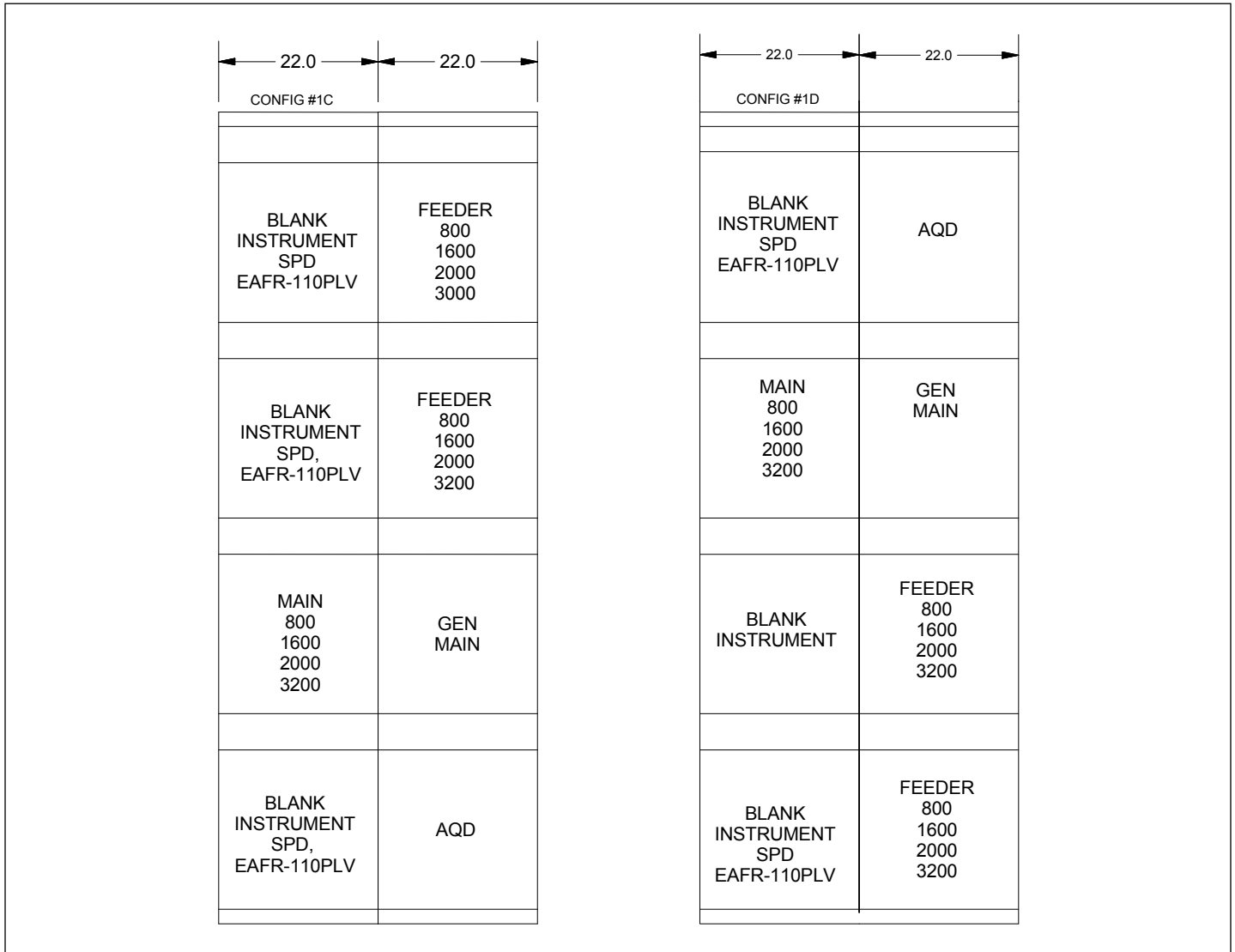

Figure 20.5-6. Breaker Arrangements—Mains (22 W and 30 W)

Note: CONFIG #1C requires bottom cross bus. CONFIG #1D requires top cross bus.
Feeder in the same structure as the main not recommended due to service entrance requirements.

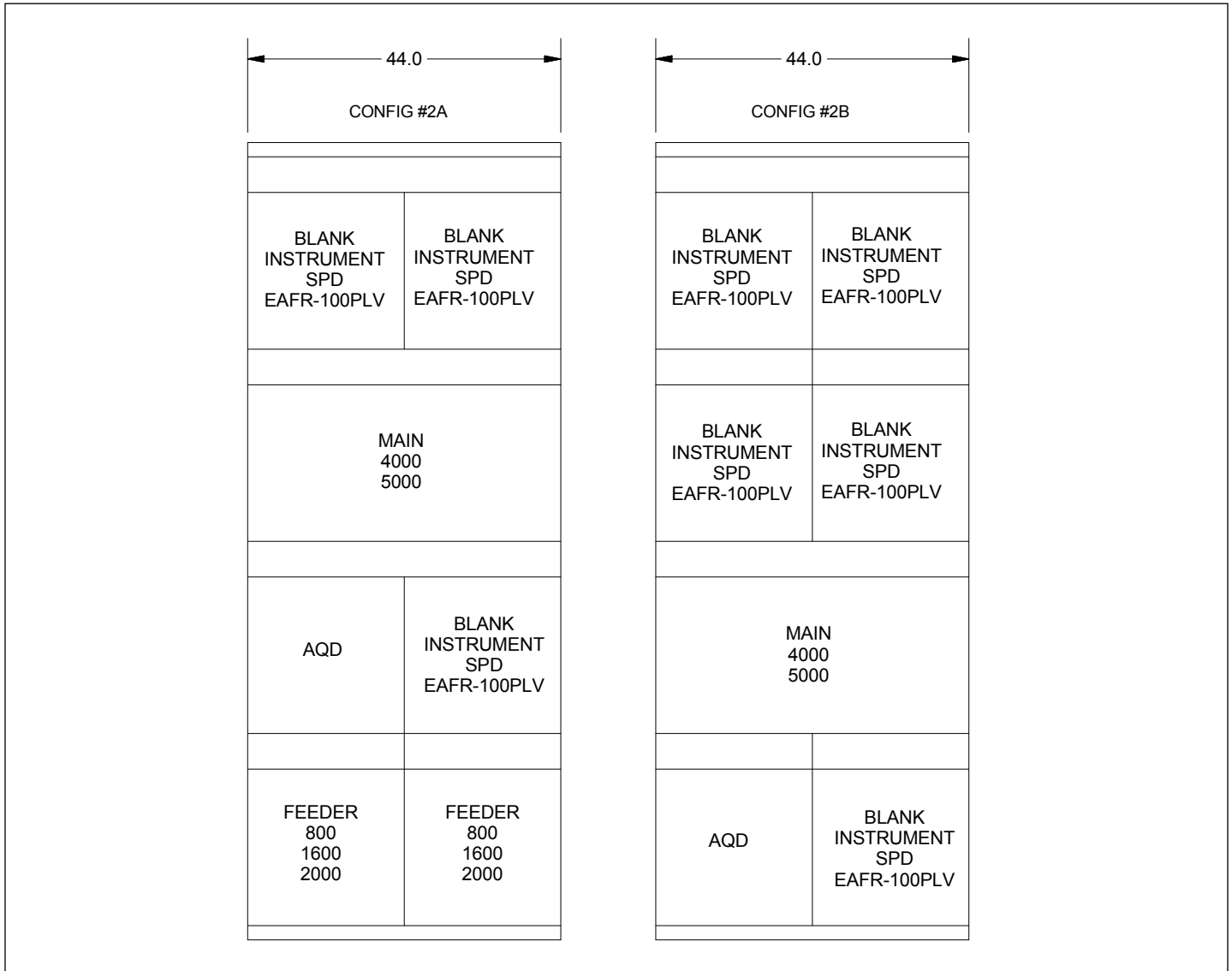

Figure 20.5-7. Breaker Arrangements—Mains

Note: Feeder in the same structure as the main not recommended due to service entrance requirements.

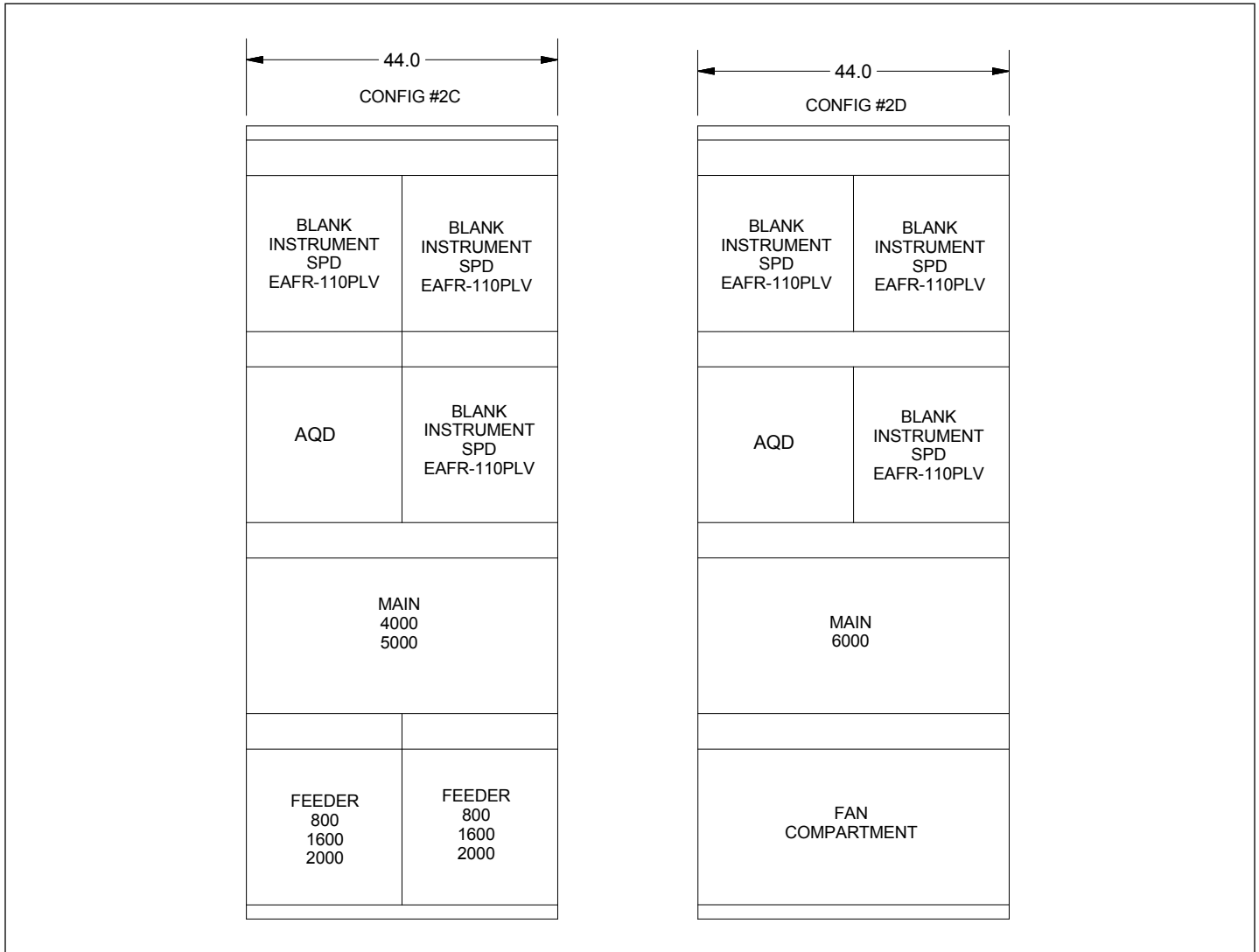

Figure 20.5-8. Breaker Arrangements—Mains

Note: AQD must be directly above a double-wide breaker on the left hand or the right hand side.

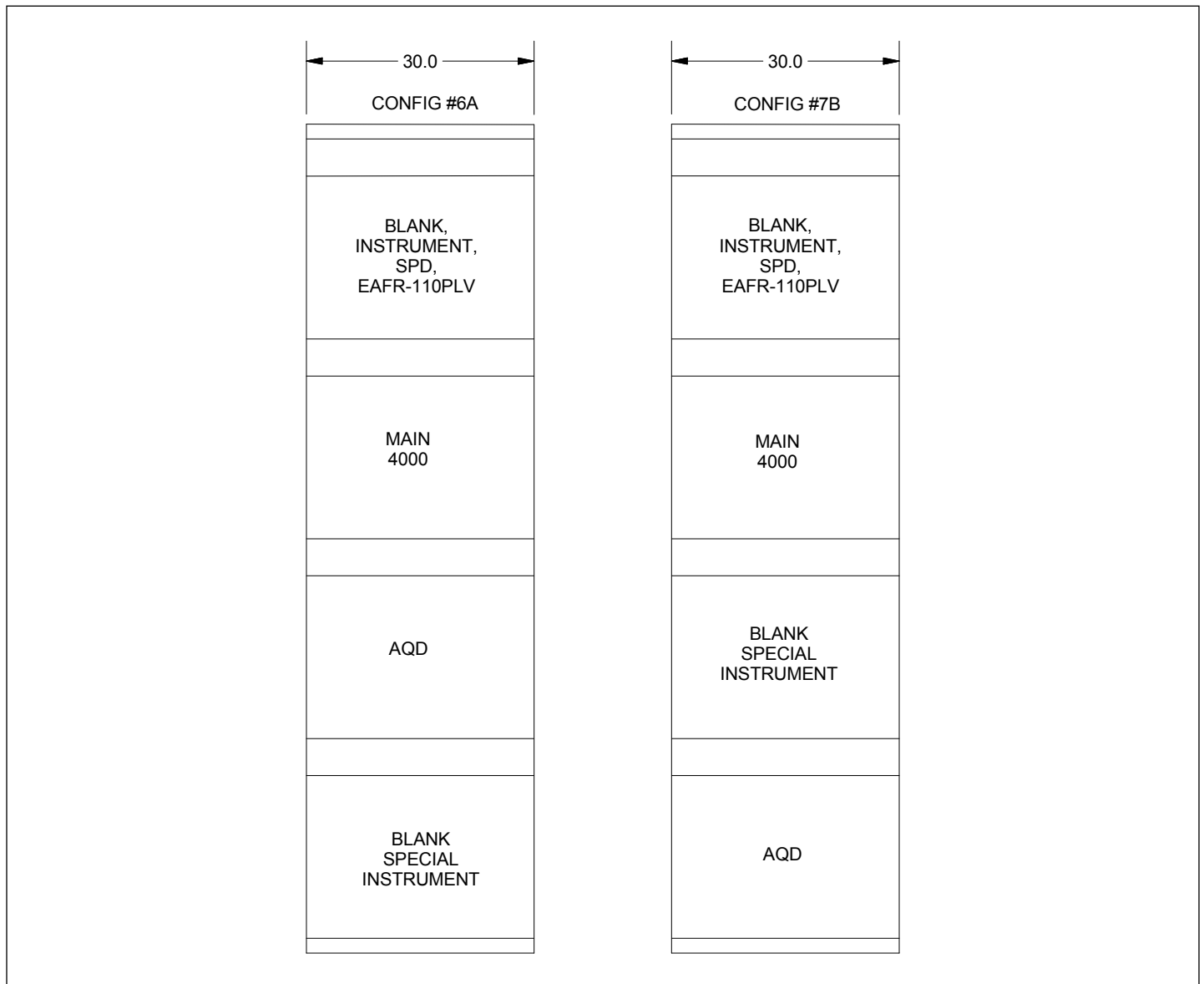

Figure 20.5-9. Breaker Arrangements—MDN4000 Mains

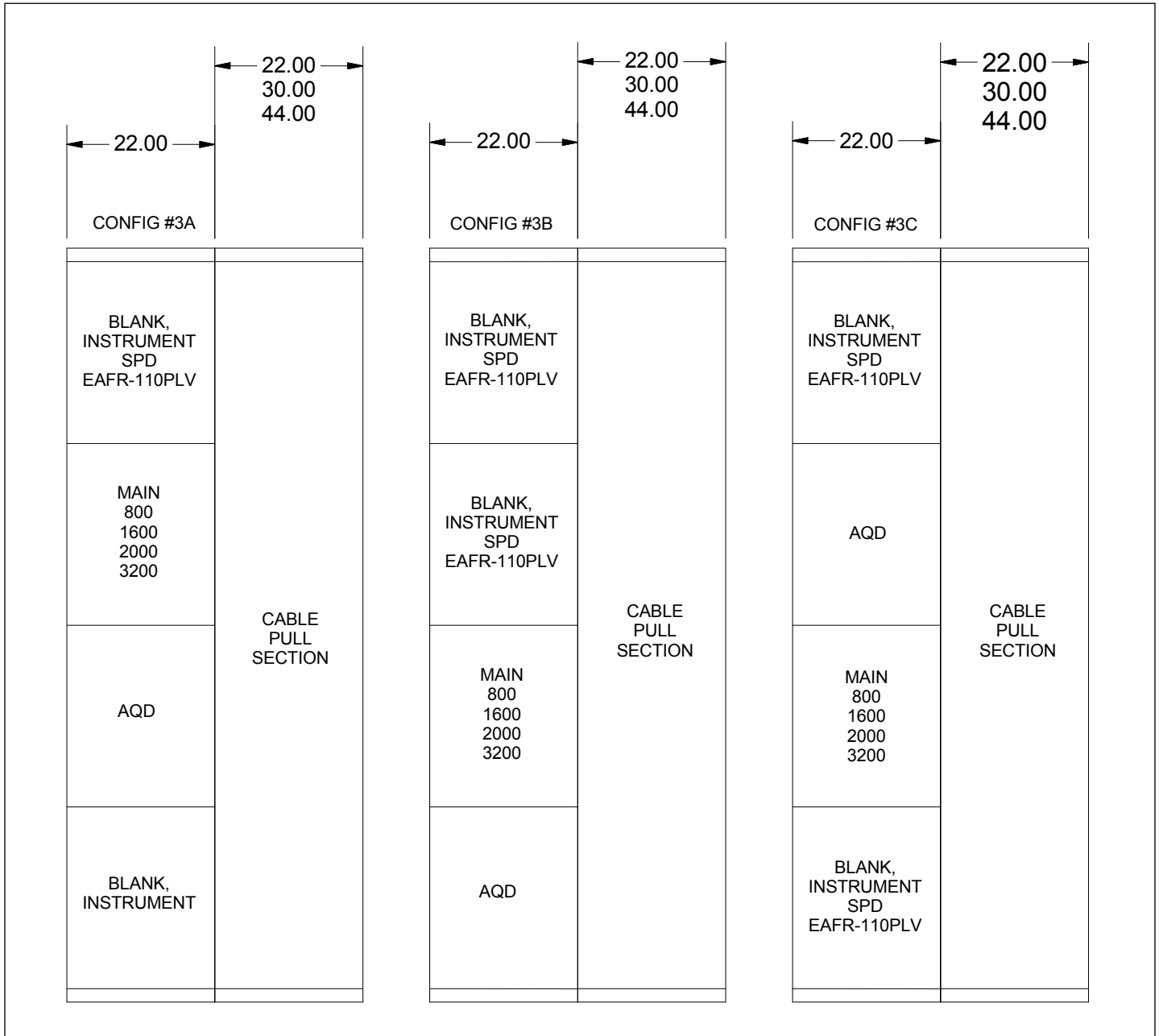

Figure 20.5-10. Breaker Arrangements—Front Access Mains

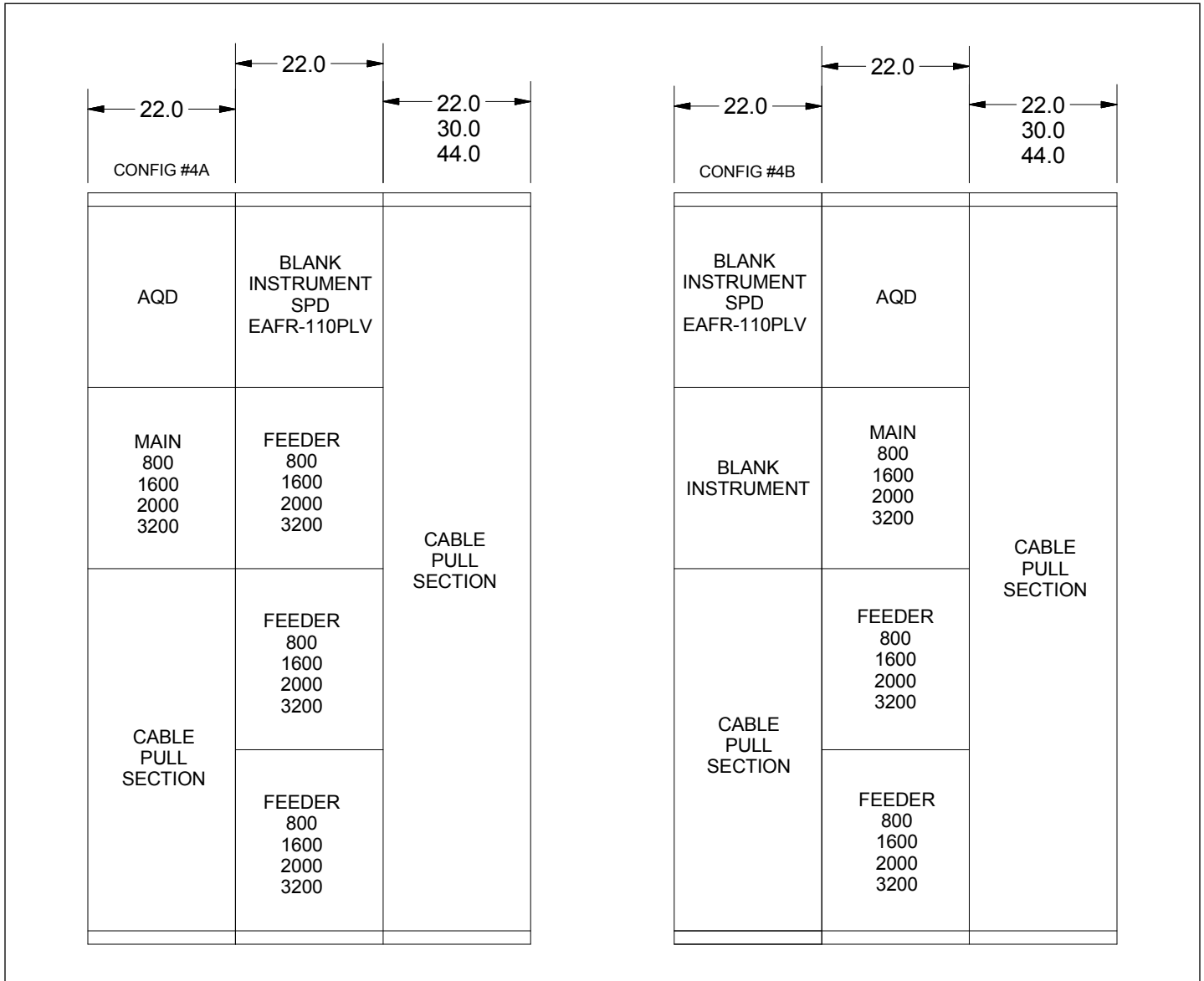

Figure 20.5-11. Breaker Arrangements—Front Access Incoming Mains

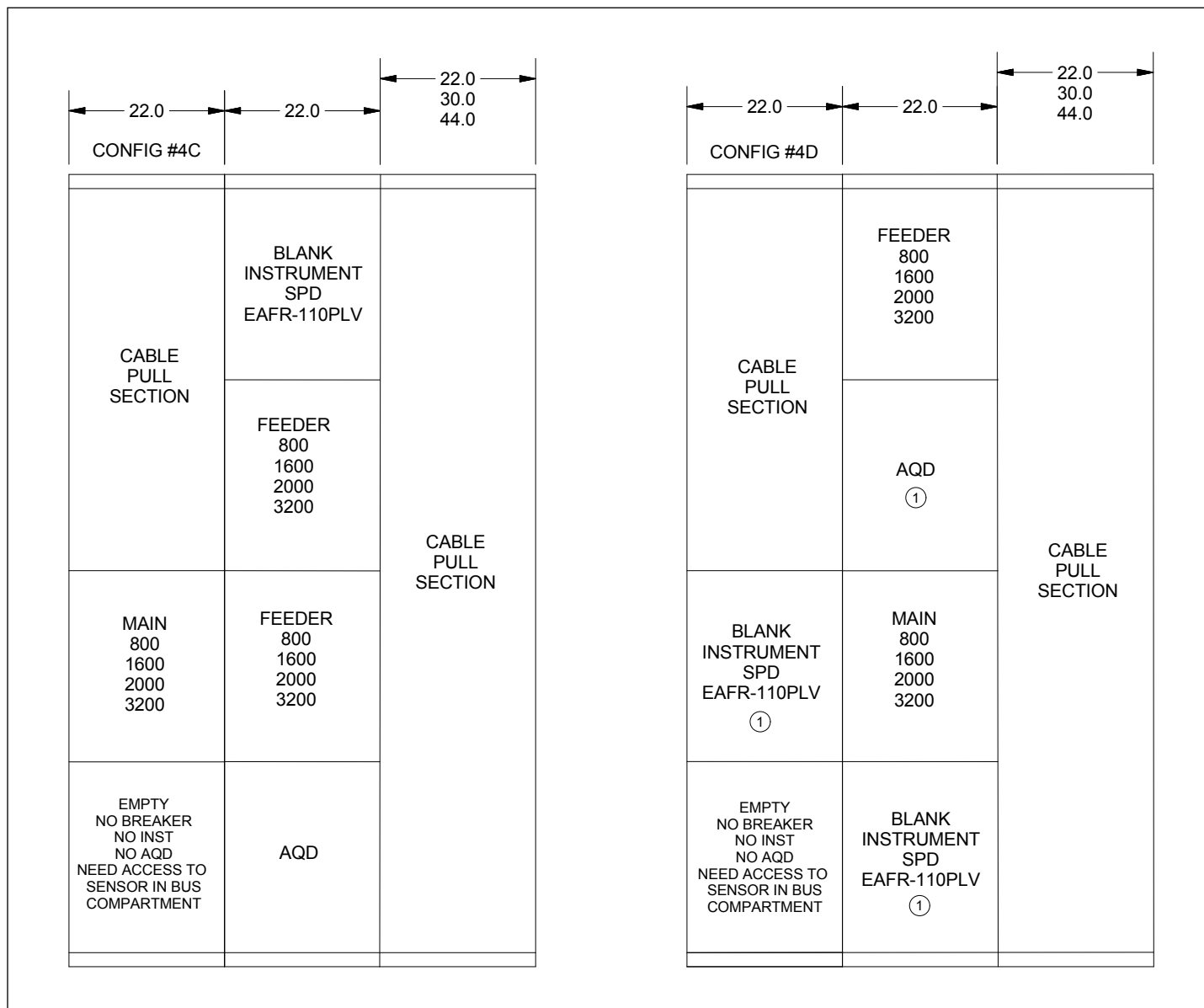

Figure 20.5-12. Breaker Arrangements—Front Access Incoming Mains

① AQD can be in any of these locations for line- or load-side applications.

Note: CONFIG #4C requires bottom cross bus.

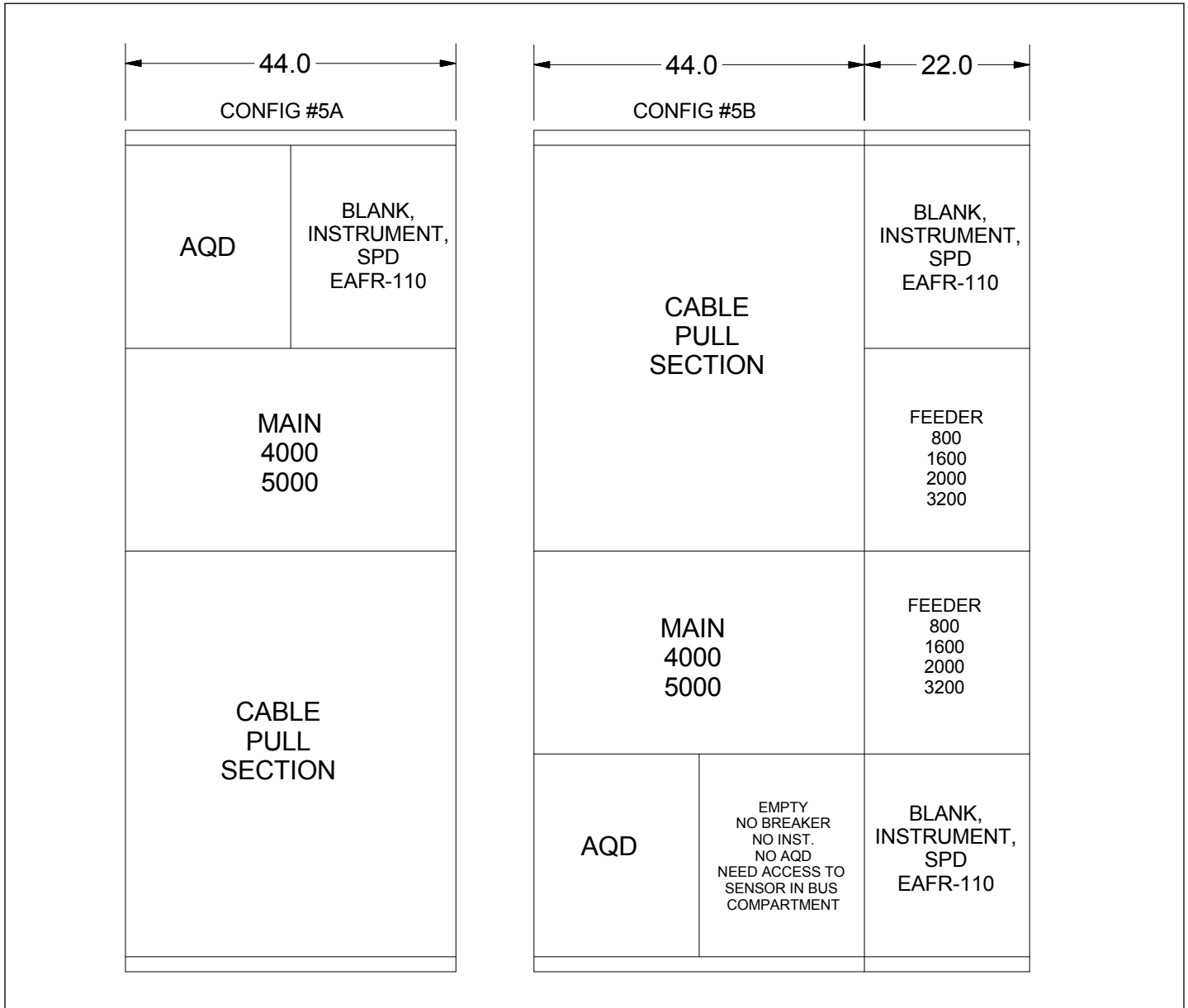

Figure 20.5-13. Breaker Arrangements—Front Access Incoming Mains

EAFR Location

The main EAFR-110PLV relay must be located in the same structure as the low-voltage main breaker and the AQD. Adequate instrument compartment door space must be allocated for this device. See **Figure 20.5-14** and **Figure 20.5-15**.

Each low-voltage main breaker requires an EAFR-101C relay. This relay may be located in the same instrument compartment as the EAFR-110PLV relay. Adequate instrument compartment door space must be allocated for this device. See **Figure 20.5-16** and **Figure 20.5-17**.

For every two feeders or tie breakers, an additional EAFR-101C relay is required. The location of these relays within the lineup is not critical; however, they should be located in the same shipping split as the feeder or tie breakers that they are associated with. Adequate instrument compartment door space must be allocated for these devices. See **Figure 20.5-16** and **Figure 20.5-17**.

- One EAFR-110PLV and up to seven EAFR-101C relays can fit on the door of a standard 22-inch wide instrument compartment
- One EAFR-110PLV and up to 11 EAFR-101C relays can fit on the door of a standard 30-inch wide instrument compartment
- Up to 10 EAFR-101C relays can fit on the door of a standard 22-inch wide instrument compartment
- Up to 14 EAFR-101C relays can fit on the door of a standard 30-inch wide instrument compartment

See **Figure 20.5-18** through **Figure 20.5-21** for door layouts.

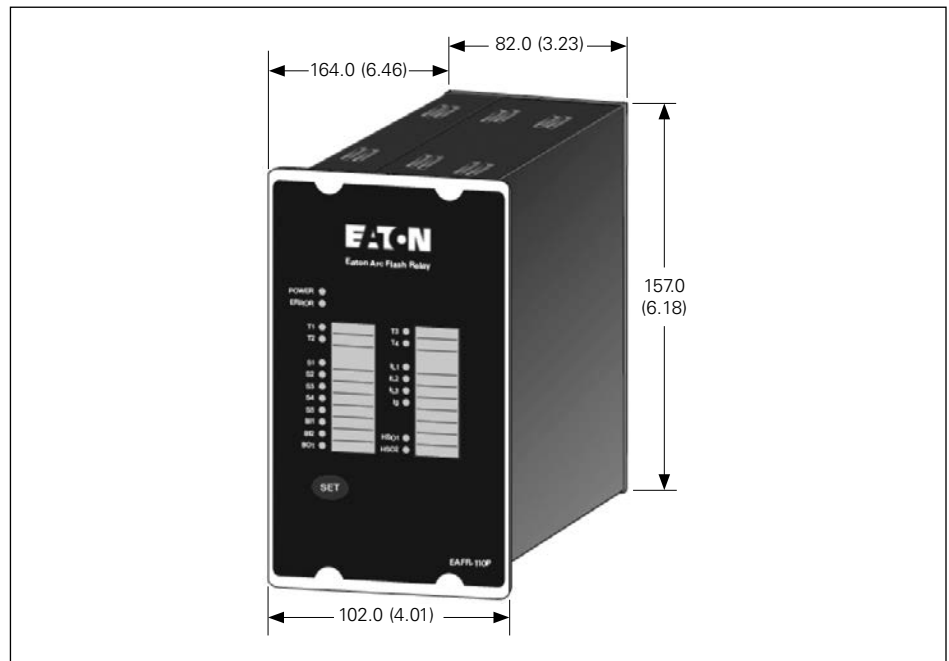

Figure 20.5-14. EAFR-110PLV Dimensions in Millimeters (Inches)

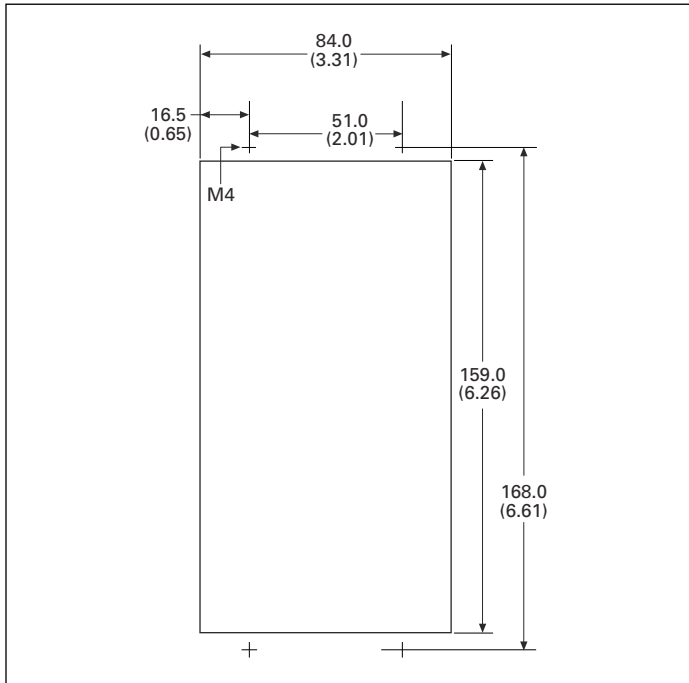

Figure 20.5-15. EAFR-110PLV Cutout for Panel Mounting in Millimeters (Inches)

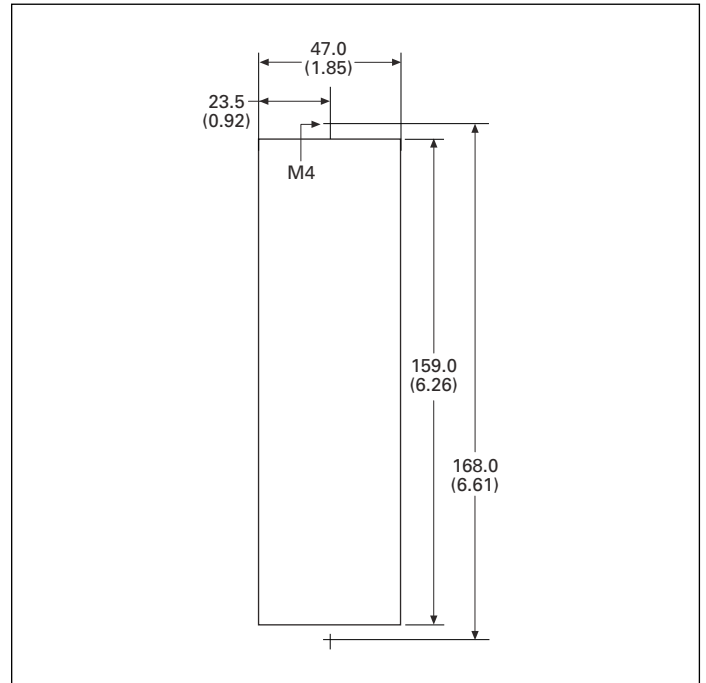

Figure 20.5-17. EAFR-101C Cutout for Panel Mounting in Millimeters (Inches)

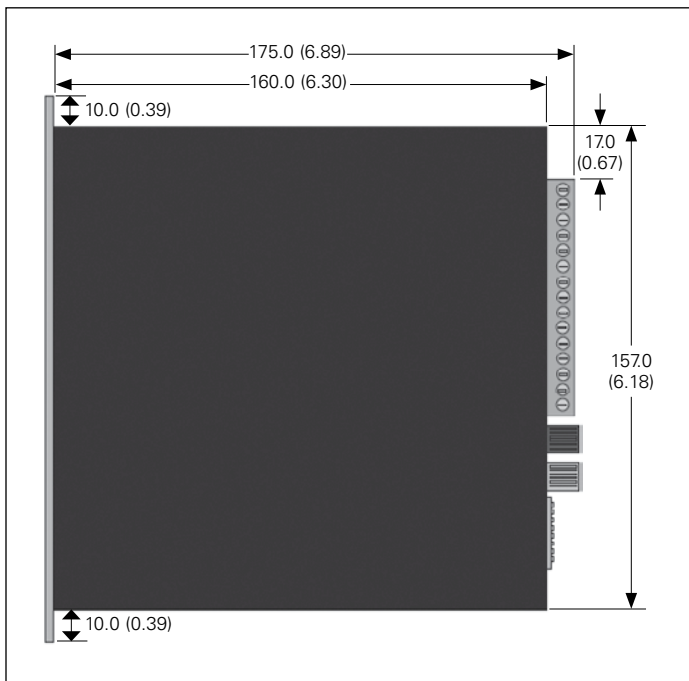

Figure 20.5-16. EAFR-101C Dimensions in Millimeters (Inches)

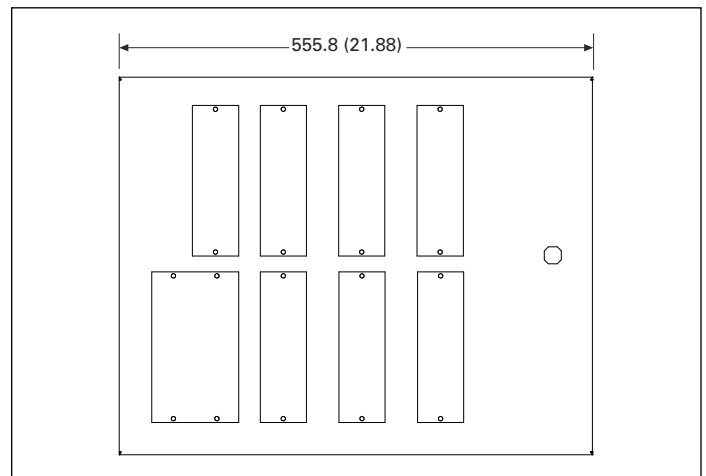

Figure 20.5-18. 22-Inch Instrument Compartment with EAFR-110PLV and EAFR-101C Relays—Dimensions in Millimeters (Inches)

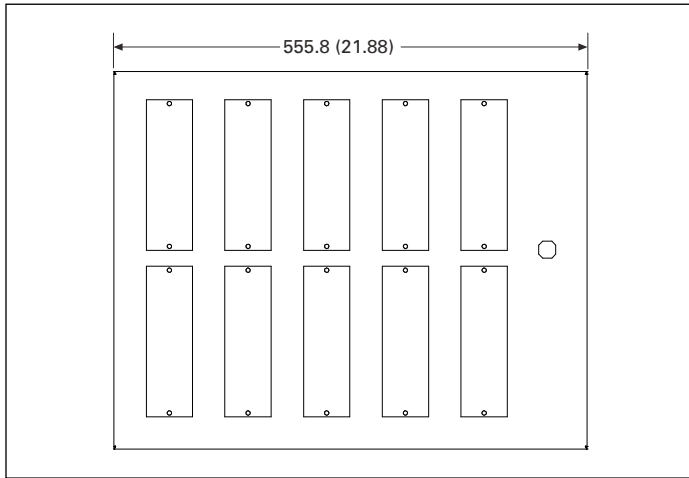

Figure 20.5-19. 22-Inch Instrument Compartment with EAFR-101C Relays—Dimensions in Millimeters (Inches)

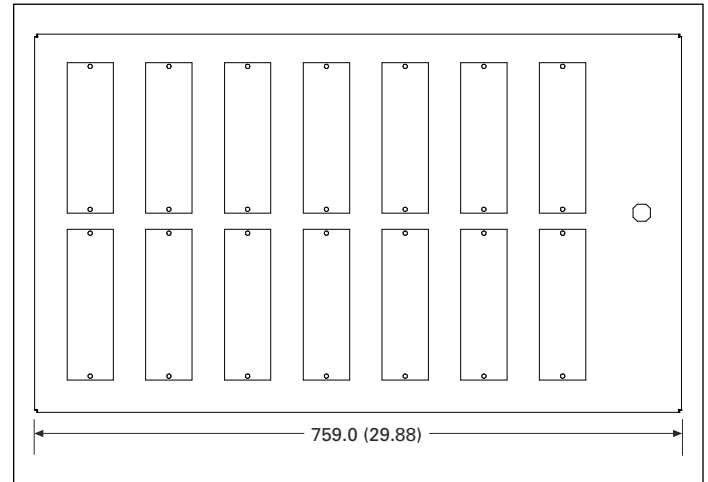

Figure 20.5-21. 30-Inch Instrument Compartment with EAFR-101C Relays—Dimensions in Millimeters (Inches)

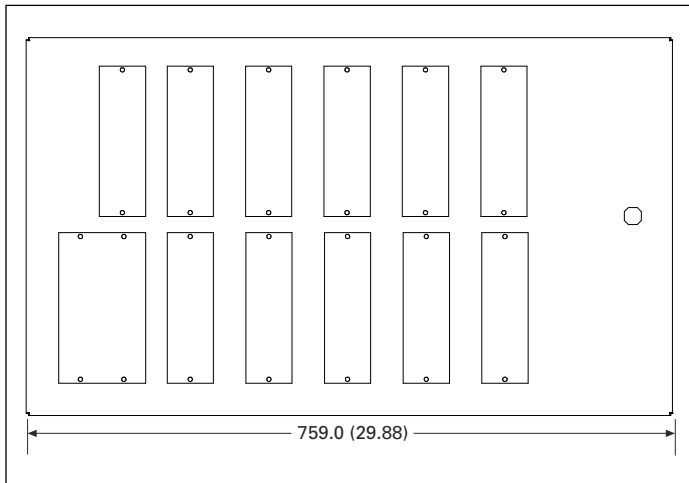

Figure 20.5-20. 30-Inch Instrument Compartment with EAFR-110PLV and EAFR-101C Relays—Dimensions in Millimeters (Inches)

Sample Layouts

Multiple Main Bus Lineups (Main-Tie-Main, Main-Main, etc.)

For Arc Quenching Switchgear lineups with multiple low-voltage main (or generator) breakers and no tie breakers, a single Arc Quenching System (one load-side AQD and all required EAFR relays) may be utilized only if the main breakers are located in immediately adjacent structures (with no structures in between). The AQD may be installed below either main breaker and the EAFR trip signal will be wired to trip both main breakers when an arc flash is detected. The location requirements for the AQD and EAFR relays are the same as described above.

For Arc Quenching Switchgear lineups with main and tie breakers, a complete Arc Quenching System (one AQD and all required EAFR relays) must be included for each main breaker. When an arc flash is detected, the EAFR will trip the source breaker and trigger the associated AQD. The AQD associated with an open main breaker will never be triggered in the event of an arc fault in a main-tie-main application. The location requirements for the AQDs and EAFR relays are the same as described above.

The AQD must be applied within the nameplate ratings of the device.

A	Main metering PXM 4000 meter	(5) EAFR-101C	Instrument	Instrument
B	Main MDN-64N 4000A-DE 1150LSIG	Feeder MDS-616 1600A-DE 1150LSIG	Feeder MDS-616 1600A-DE 1150LSIG	Feeder MDS-616 1600A-DE 1150LSIG
C	(1) EAFR-110-PLV (1) EAFR-101C	Feeder MDS-616 1600A-DE 1150LSIG	Feeder MDS-616 1600A-DE 1150LSIG	Feeder MDS-616 1600A-DE 1150LSIG
D	AQD	Feeder MDS-616 1600A-DE 1150LSIG	Feeder MDS-616 1600A-DE 1150LSIG	Feeder MDS-616 1600A-DE 1150LSIG
Structure Depth (Calc)	78 (72)	78 (78)	78 (78)	78 (78)
Width	30	22	22	22
Overall width	96.00 (2438.4)			

Figure 20.5-22. Single Main, Line- or Load-Side Application

A	Main metering PXM 4000 meter	Main metering PXM 4000 meter	Instrument	Instrument	Instrument	(5) EAFR-101C
B	Main MDS-632 3200A-DE 1150LSIG	Main MDS-632 3200A-DE 1150LSIG	Feeder MDS-616 1600A-DE 1150LSIG	Feeder MDS-616 1600A-DE 1150LSIG	Feeder MDS-616 1600A-DE 1150LSIG	Feeder MDS-616 1600A-DE 1150LSIG
C		(1) EAFR-110-PLV (2) EAFR-101C	Feeder MDS-616 1600A-DE 1150LSIG	Feeder MDS-616 1600A-DE 1150LSIG	Feeder MDS-616 1600A-DE 1150LSIG	Feeder MDS-616 1600A-DE 1150LSIG
D		AQD	Feeder MDS-616 1600A-DE 1150LSIG	Feeder MDS-616 1600A-DE 1150LSIG	Feeder MDS-616 1600A-DE 1150LSIG	Feeder MDS-616 1600A-DE 1150LSIG
Structure Depth (Calc)	78 (72)	78 (72)	78 (78)	78 (78)	78 (78)	78 (78)
Width	30/22	30/22	22	22	22	22
Overall width	148.00 (3759.2)					

Figure 20.5-23. Main-main, Load-Side Application

A	Main metering PXM 4000 meter	(4) EAFR- 101C	Instrument	Transfer scheme	Instrument	(3) EAFR- 101C	Main metering PXM 4000 meter
B	Main MDN-64N 4000A-DE 1150LSIG	Feeder MDS-616 1600A-DE 1150LSIG	Feeder MDS-616 1600A-DE 1150LSIG	Tie MDN-64N 4000A-DE 1150LSIG	Feeder MDS-616 1600A-DE 1150LSIG	Feeder MDS-616 1600A-DE 1150LSIG	Main MDN-64N 4000A-DE 1150LSIG
C	(1) EAFR- 110-PLV (1) EAFR- 101C	Feeder MDS-616 1600A-DE 1150LSIG	Feeder MDS-616 1600A-DE 1150LSIG		Feeder MDS-616 1600A-DE 1150LSIG	Feeder MDS-616 1600A-DE 1150LSIG	(1) EAFR- 110-PLV (1) EAFR- 101C
D	AQD	Feeder MDS-616 1600A-DE 1150LSIG	Feeder MDS-616 1600A-DE 1150LSIG		Feeder MDS-616 1600A-DE 1150LSIG	Feeder MDS-616 1600A-DE 1150LSIG	AQD
Structure Depth (Calc) Width	1 78 (72) 30	2 78 (78) 22	3 78 (78) 22	4 78 (72) 30	* 5 78 (78) 22	6 78 (78) 22	7 78 (72) 30
Overall width	← 178.00 (4521.2) →						

Figure 20.5-24. Main-tie-main, Line- or Load-Side Application

Note: See other product families for breaker layouts and dimensions.