



R5/A5 Series Cylinders

NFPA Interchangeable



HYDRO-LINE, INC.



An IMC Company

Table Of Contents

R5 & A5 Standard Design Options	page 2
R5 & A5 Design Features	pages 3-4
R5 & A5 Specifications.....	page 5
R5 & A5 Custom Cylinders	page 6
How to Order an A5	page 7
How to Order an R5.....	page 8
Application Data Sheet	page 9
R5 & A5 Cylinder Types.....	page 10

R5 & A5 Mounting Application Data	page 11
R5 & A5 Mounting Dimensions	pages 12-21
Technical Data.....	pages 22-25
Cylinder Mounting Accessories.....	pages 26-29
Warranty.....	page 29
Low Profile Reed & Hall Effect Switches	pages 30-31
Oversized Rods.....	page 32
Rod End Styles	page 33

R5/A5 Series Standard Design Options

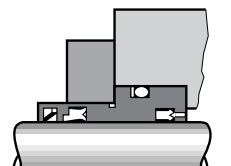

Metallic Rod Scrapers

A Metallic Rod Scraper provides increased rod seal life by removing abrasive contamination from the rod in severe applications.

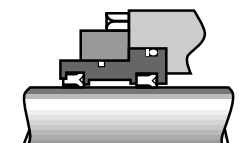

Wearbands

Wearbands fitted to the piston and/or rod cartridge eliminate metal-to-metal contact on the piston/tube I.D. and the cartridge/rod O.D. Bronze-filled Teflon wearband material reduces friction and wear in applications where side-load is present.

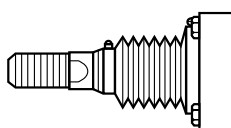

Rod Boots

A rod boot surrounds the piston rod with an external, expandable cover to protect the rod surface from external contamination. Requires additional rod length which is determined by the cylinder stroke.

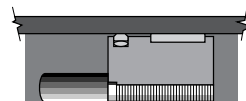

Low Breakaway Piston

A low breakaway piston reduces breakaway and running friction and eliminates metal-to-metal contact by utilizing a bronze-filled Teflon wearband and a bi-directional, o-ring energized, bronze-filled Teflon piston seal.

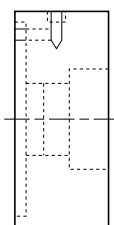

Air Bleeders

When specifying bleeders, $\frac{1}{8}$ " NPTF is standard with SAE #2 as an option. Bleeders are located in the cylinder end caps. They may be located in positions 1, 2, 3 or 4.

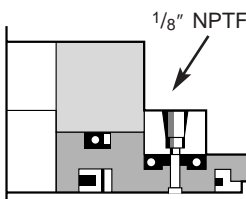

Drainback Ports

Drainback ports are used to return fluid to the tank that accumulates between the rod seal and rod wiper. Port position No. 1 is standard with alternate locations at 2, 3 and 4. $\frac{1}{16}$ " NPTF is standard on $\frac{5}{8}$ " and 1" diameter rods. $\frac{1}{8}$ " NPTF is standard on larger rod diameters.

Special Rod Ends

Modifications of standard rod ends or completely special rod end styles are available to meet unique rod end connection requirements. (See page 33 for standard rod ends.)

Special Ports

Metric, BSP, NPTF, SAE, Manifold, Flange and other porting options are available to meet specific requirements. (See page 24.)

Extra Heavy Chrome Tubes and Rods

Added wear and corrosion resistance are available by specifying Extra Heavy Chrome (.002" to .003" thick). Not available on A5 Series cylinders.

Electronic Feedback

A complete line of precision cylinder position sensing and feedback devices are available. These packaged cylinder systems can handle virtually any application requiring feedback throughout the cylinder stroke — pneumatic or hydraulic, large or small bore, long or short strokes, with or without velocity monitoring — with resolutions of ± 0.001 " or better. (See the Hydro-Line Systems Catalog.)

Plating

Electroless Nickel, Cadmium and other plating finishes are available for corrosive, washdown, pharmaceutical, and other applications.

Low Profile Reed & Hall Effect Switches

Hydro-Line Low Profile Reed and Hall Effect switches are available for all bore size A5 Series cylinders. These switches are activated by a magnetic band fitted around the cylinder piston. Signals from these switches are used as input to programmable controllers, sequencers, relays, and in some cases, to drive valve solenoids. See page 30-31 for specifications. Not Available on R5 Series cylinders.

Stainless Steel Piston Rods

Piston rods in 300 and 400 series, 17-4 PH, and others are available for those applications requiring increased corrosion resistance.

Special Coating and Painting

Cylinders can be prepared with a primer coat or epoxy, lacquer, or enamel paint finish coatings to customer specifications. Synergistic, Nitrocarburizing and other material treatments are also available for special applications.

Special Materials

Bronze rod cartridges, brass, aluminum and composite tubing, complete stainless steel cylinders or other special materials are available to meet most unique material requirements.

R5 & A5 Design Features

A Heavy Duty Rod Cartridge

- Machined from gray iron for maximum bearing support and wear resistance
- Unitized, threadless assembly is pilot fitted into the head on a precision bored diameter to assure true concentricity (See Fig. 3-1)

B Piston Seals

- Nitrile lip-type seals standard on R5, LR5, HR5, LA5 and HA5
- Step cut iron piston rings optional on HR5
- Viton lip seals available for special fluid compatibility or temperatures to 400°F
- Special seals for high speed, low friction and other requirements are available

C Piston

- Ductile iron piston on R5 for strength and durability
- Aluminum piston on A5. Magnetic ring for switch operation optional (not shown)

D Pressure Energized Rod Seal

- Nitrile rod seal standard, assures positive sealing with low drag
- Viton rod seal available for special fluid compatibility or temperatures to 400°F
- Special seals for high speed, low friction and other requirements are available.
- Polymyte backup ring is standard

E Double-Lipped Rod Wiper

- Nitrile double-lipped rod wiper removes foreign materials from the exposed rod to extend rod seal life
- The standard rod wiper is nitrile material through 5 1/2"; Viton for 7" through 10" diameter rods
- Metallic rod scraper and low friction wipers available

F Ports

- SAE ports standard on HR5 and HA5; NPTF ports available at no extra charge
- NPTF ports standard on R5, LR5, A5 and LA5; SAE ports available at no extra charge
- Metric, BSP Manifold, Flange and other porting options available

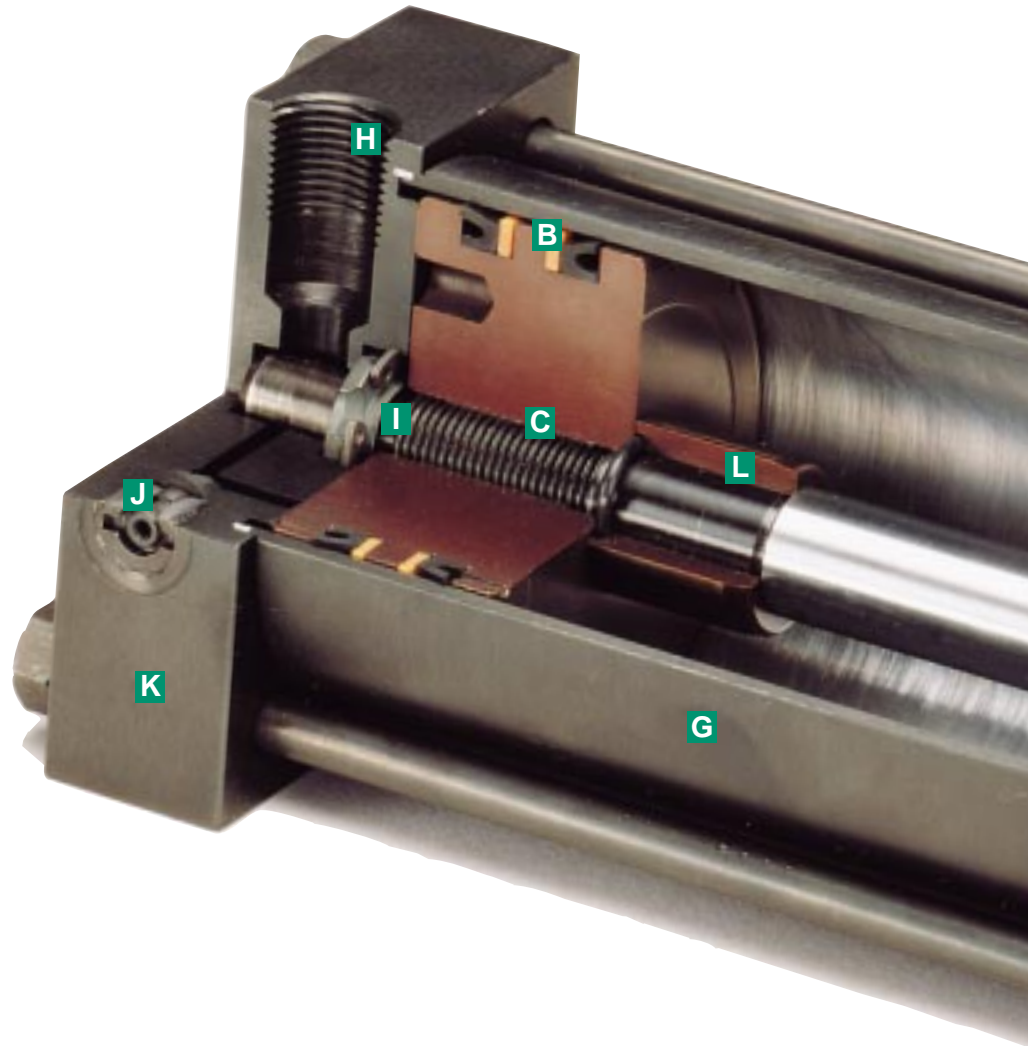

Key Features

Unitized Rod Cartridge Construction

- The unitized construction contains all cartridge seals in one assembly.
- Standard removable retainer allows cartridge removal with hex wrench without loosening the tie rods.
- See Page 5 for exceptions.

Fig. 3-1

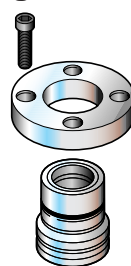

Sculptured Floating Cushions

Self-centering cushions are sculptured to allow the cylinder driving force and load to be absorbed gradually and smoothly over the entire cushion length maintaining near constant pressure.

Fig. 3-2

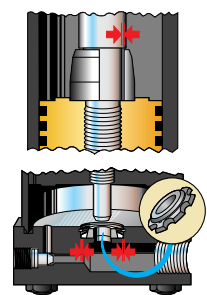

G Damage Resistant Tubing

- High strength chrome plated steel tubing is standard on R5 for dent resistance and rigidity
- Hardcoat anodized aluminum alloy tubing standard on A5 for resistance to corrosion and scoring
- Tubing I.D. finished for low frictional drag and maximum seal life on R5 and A5

H Teflon Tube Seals

- Superior design to prevent leakage
- Compatible with virtually all fluids

I Floating Cap Cushion Insert

- Floating design allows closer tolerance, yet minimum wear (See Fig. 3-2)
- Replaces ball check to provide greater flow area for fast breakaway

J Captive Cushion Adjustment

- Inner Hex allows safe cushion adjustment under pressure
- Fine threads and special tip design allows for precise adjustment over a broad range of operating conditions

K Precision Steel Heads and Caps

- Provides truly flat and parallel mounting surfaces
- Insures correct alignment of tube and rod cartridge

L Self-Centering Head Cushion

- Floating design allows closer tolerances, yet minimum wear (See Fig. 3-2)
- Sculptured shape provides constant deceleration curve
- Large size ball check provided at head end for fast breakaway

M Damage Resistant Piston Rod

- $\frac{5}{8}$ " through $4\frac{1}{2}$ " diameters use 90,000 to 100,000 minimum PSI yield steel, case hardened and hard chrome plated
- Over 5" diameter uses 41,000 to 80,000 PSI yield steel, hard chrome plated
- All rods polished to 8-14 micro inch finish for long seal life
- 17-4 PH stainless steel and other materials also available

N Studded Piston Rod End

- Roll threaded 125,000 minimum PSI yield steel
- Greater strength and fatigue resistance
- Standard on $\frac{1}{2}$ ", $\frac{5}{8}$ ", 1" and $1\frac{3}{8}$ " diameter rods in styles 1, 1X, 2 and 2X
- Available on $1\frac{3}{4}$ ", 2" and $2\frac{1}{2}$ " rods in styles 1, 1X, 2 and 2X upon request

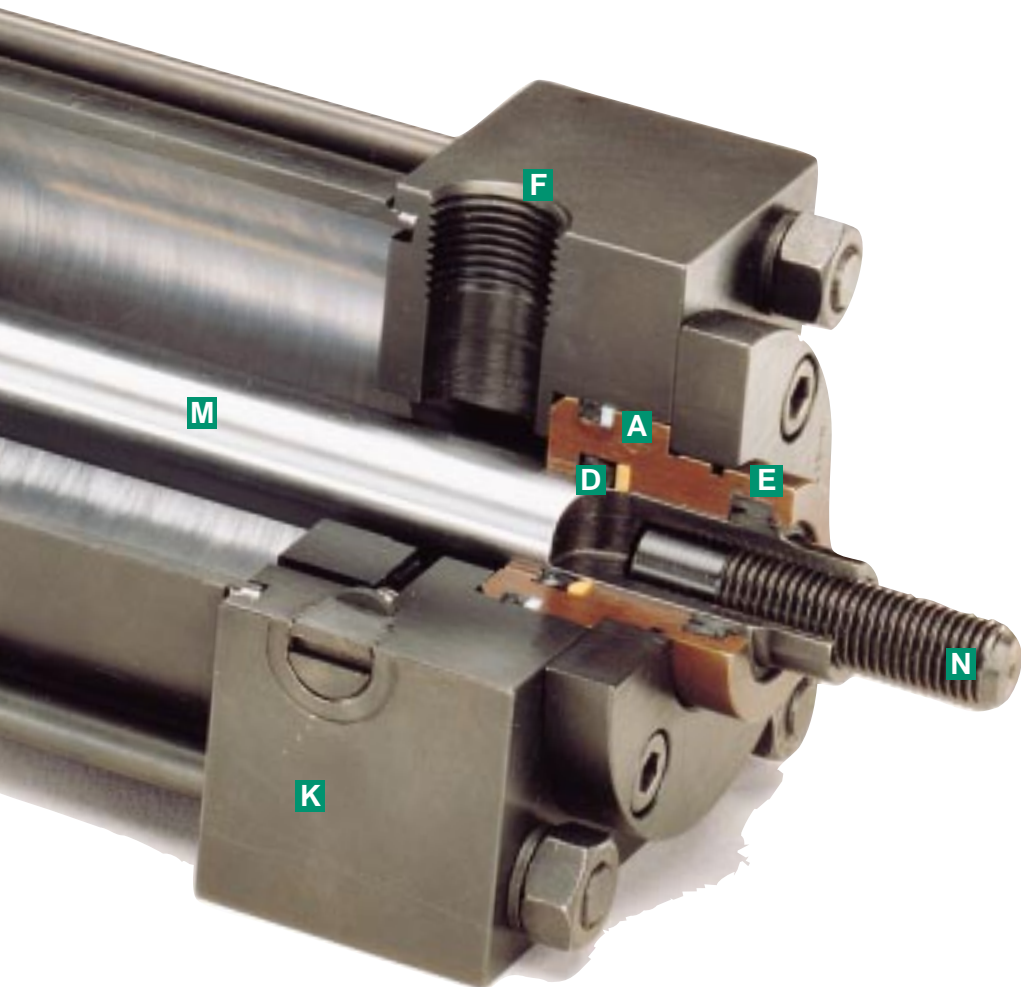

R5 and A5 Specifications

R5 Specifications

Bore Sizes: R5 – 1" through 20"

Pressure R5, LR5 – 250 psi pneumatic - nominal

Ratings: HR5 – See page 23 for specific pressure ratings and safety factors

Temperature: -40°F to 200°F standard

NFPA interchangeable mountings

R5: Pneumatic cylinders incorporate a nitrile lip-type rod seal, nitrile double-lipped rod wiper, nitrile lip-type piston seals, .0003/.0005" thick chrome plated tube I.D., and NPTF ports.

HR5: Hydraulic cylinders incorporate a urethane Ultra-Seal rod seal, nitrile double-lipped rod wiper, nitrile lip-type piston seals, .0003/.0005" thick chrome plated tube I.D., and SAE ports.

LR5: Pneumatic cylinders incorporate all R5 features and are also permanently lubricated at assembly by filling the piston and rod seals "V" groove with molybdenum disulfide grease.

A5 Specifications

Bore Sizes: A5 – 1 1/2" through 6"

Pressure A5, LA5 – 250 psi pneumatic - nominal

Ratings: HA5 – 400 psi hydraulic - nominal

Temperature: -40°F to 200°F standard

NFPA interchangeable mountings

A5: Pneumatic cylinders incorporate a nitrile lip-type rod seal, nitrile double-lipped rod wiper, aluminum piston, nitrile lip-type piston seals, aluminum tubing with finished I.D., and NPTF ports.

HA5: Hydraulic cylinders incorporate a urethane Ultra-Seal rod seal, nitrile double-lipped rod wiper, aluminum piston, nitrile lip-type piston seals, aluminum tubing with finished I.D., and SAE ports.

LA5: Pneumatic cylinders incorporate all A5 features and are also permanently lubricated at assembly by filling the piston and rod seals "V" groove with molybdenum disulfide grease.

Rod Cartridge Retainers Simplify Cartridge Removal

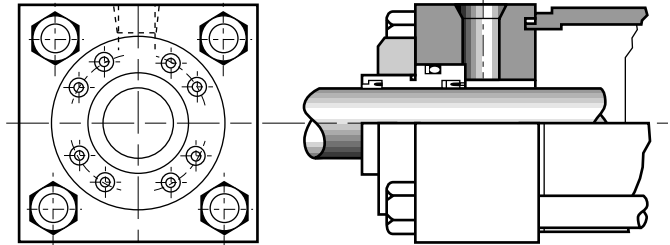

Circular retainers permit removal of rod cartridge without disassembling cylinder. Refer to Figure 5-1 to identify which bore and rod combinations use this above design. (C is designated for circular retainer.)

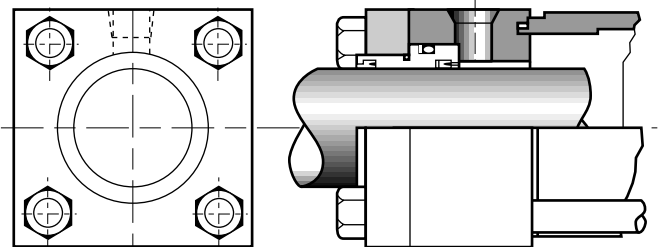

Refer to Figure 5-1 to identify which bore and rod combinations use the above design. (F is designated for full front plate.)

Figure 5-1

Bore Size	Rod Size								
	1/2	5/8	1	1 3/8	1 3/4	2	2 1/2	3	3 1/2
1	F	F							
1 1/2		F	F						
2		F	F	F					
2 1/2		C	C	F	F				
3 1/4			C	C	F	F			
4			C	C	C	C	F		
5			C	C	C	C	C	F	F
6-30				C	C	C	C	C	C

* G mounts use circular retainer construction.

* 4" rod diameters and larger use circular retainer construction

Custom Cylinders

For Special Applications

Hydro-Line's full line of cylinder products and options fit most customers' application requirements, however, a special cylinder is often required to meet custom specifications. These custom cylinders are often needed to solve difficult application problems, upgrade existing equipment or are designed into new machinery.

Hydro-Line's Sales, Engineering and Manufacturing groups are cylinder specialists and have many years of experience in the interpretation of requirements, design and manufacture of custom cylinder products.

Our capabilities include:

- Bore diameters to 30"
- Stroke lengths to 300"
- Operating pressures to 10,000 psi or higher
- Operating media ranging from shop air to nitrogen, or from standard hydraulic fluid to special synthetic fluids
- Tie rod, threaded, and bolted cylinder construction
- Finite element analysis
- Application simulation in our testing laboratories

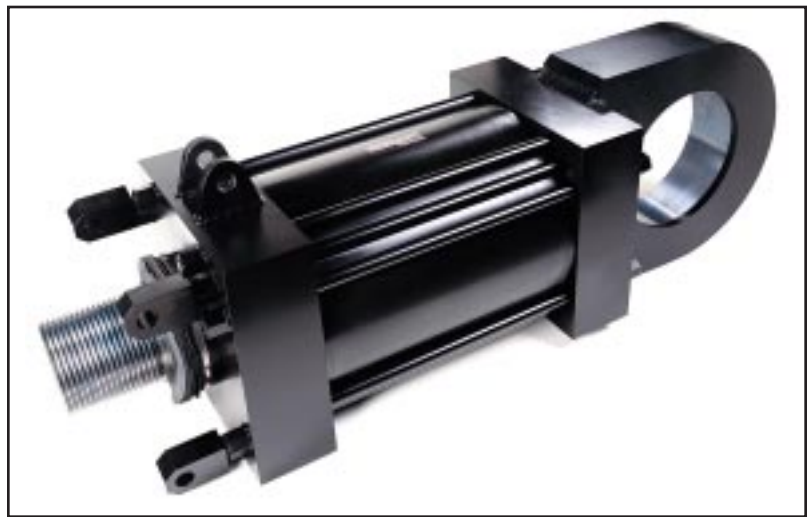

= Solutions

Hydro-Line would appreciate an opportunity to submit a proposal to solve your application problem or fulfill your current cylinder requirements. Simply copy and complete the Application Data Sheet on page 9 and fax to your authorized Hydro-Line distributor.

How to Order an A5 Cylinder

Hydro-Line standard cylinders can be completely and accurately identified with a model number that encodes construction specifications. To develop the model number for ordering a cylinder, see the following example:

Feature	Description	Symbol	
Rod Diameter	Specify in inches (2 position decimal)	-	
Cushions	Noncushioned	N	
	Cushioned both ends	B	
	Cushioned head end	H	
	Cushioned cap end	C	
Stroke	Specify in inches (2 position decimal)	-	
Bore	Specify in inches (2 position decimal)	-	
Double Rod	Include ONLY for double-rod cylinder	D	
Mounting Style	Side lugs, MS2	A	
	Side tapped, MS4	B	
	Cap fixed clevis, MP1	C	
	Cap detachable clevis, MP2	DC	
	Side end lugs, MS7	E	
	Head rectangular flange, MF1	F	
	Head square flange, MF5	J	
	No mount	K	
	All tie rods extended, MX1	L	
	Head end tie rods extended, MX3	M	
	Cap end tie rods extended, MX2	N	
	Cap rectangular flange, MF2	R	
	Cap square flange, MF6	S	
	Intermediate fixed trunnion, MT4	TT	
	Head trunnion, MT1	U	
	Cap trunnion, MT2	W	
	Model Series	Air 250 psi	A5
		Air prelubricated 250 psi	LA5
Hydraulic 400 psi		HA5	
Rod End Style	Male, large	1	
	Male, large, extended	1X	
	Male, small (standard)	2	
	Male, small, extended	2X	
	◆ Male modified	2M	
	Female	4	
	◆ Female modified	4M	
	Plain end	5	
	Male, full rod diameter	6	
	Male, for rod end coupling	10	
	◆ Modified	M	
	Ports	NPTF	N
		SAE	S
Manifold		M	
Flange		F	
BSP/G		G	
◆ Special		X	
Rod Seals	Urethane Ultra-Seal	H	
	Nitrile lip type	N	
	Nitrile ELF rounded lip type	L	
	PolyPak	P	
	Viton PolyPak	F	
	Viton lip type	V	
	Ultra-Seal with scraper	J	
	Nitrile lip type with scraper	S	
	Viton PolyPak with scraper	G	
	Viton lip type with scraper	U	
	◆ Special	X	
Piston Seals	Nitrile lip type	N	
	Nitrile ELF rounded lip type	L	
	Low friction PolyPak	D	
	PolyPak	P	
	* Viton Lip Type	V	
	Low breakaway Teflon radial seal with wearband	B	
	Magnetic piston (2 switches) Hall Effect	F	
	Magnetic piston (1 switch) Hall Effect	G	
	Magnetic piston (no switches) Hall Effect	H	
	Magnetic piston (2 switches) Reed	M	
	Magnetic piston (1 switch) Reed	O	
	Magnetic piston (no switches) Reed	S	
	◆ Special	X	
Port Locations	Head End	1 thru 4	
	◆ Special	X	
	Cap End	1 thru 5	
Special Modifications	◆ Include ONLY if special modifications are required.		
	Air bleeders	Rod boots	
	Drainbacks	Four rod end flats	
	Special seals	Port or cushion modifications	
	Nonstd. mount		
	Oversize ports	Double-end rod with different rod ends	
	Bronze bushings	Special paint/plating	
	Key Plate		
	Stainless steel rod	Stop tube	
			X

HOW TO ORDER

- Quantity
- Model number
- Special modifications if required
- Completed Application Data Sheet(s) (page 9) if required.
- Required ship date



HYDRO-LINE, INC.
ROCKFORD, IL

A5KD-3.25X8.00-N-1-2-N-N-N-1-1-X
194011234-1
A11579-375

Customer Number (if desired)
Hydro-Line Serial Number

A5KD - 3.25 X 8.00 - N - 1 - 2 - N - N - N - 1 - 1 - X



National
FLUID POWER
Association
MEMBER

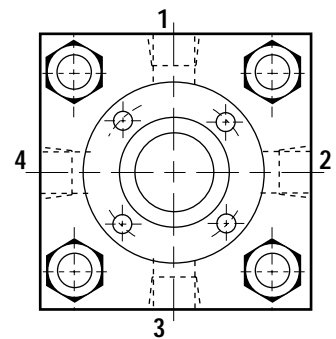

Port Locations

Port location 5 is on the center of the back face of the end cap.

- ◆ Include drawing or description
- * If selected for high temperature, it should be specified to pin the piston to the rod.
- Urethane Ultra -Seal is standard on HA5 hydraulic

How to Order an R5 Cylinder

Hydro-Line standard cylinders can be completely and accurately identified with a model number that encodes construction specifications. To develop the model number for ordering a cylinder, see the following example:

Feature	Description	Symbol
Rod Diameter	Specify in inches (2 position decimal)	-
Cushions	Noncushioned	N
	Cushioned both ends	B
	Cushioned head end	H
	Cushioned cap end	C
Stroke	Specify in inches (2 position decimal)	-
Bore	Specify in inches (2 position decimal)	-
Double Rod	Include ONLY for double-rod cylinder	D
Mounting Style	Side lugs, MS2	A
	Side tapped, MS4	B
	Cap fixed clevis, MP1	C
	Cap detachable clevis, MP2	DC
	Side end lugs, MS7	E
	Head rectangular flange, MF1	F
	Head rectangular, ME5	G
	Centerline lugs, MS3	H
	Head square flange, MF5	J
	No mount	K
	All tie rods extended, MX1	L
	Head end tie rods extended, MX3	M
	Cap end tie rods extended, MX2	N
	Cap rectangular, ME6	P
	Cap rectangular flange, MF2	R
	Cap square flange, MF6	S
	Intermediate fixed trunnion, MT4	TT
	Head trunnion, MT1	U
	Cap trunnion, MT2	W
	Model Series	Air 250 psi
Air prelubricated 250 psi		LR5
Hydraulic medium pressure		HR5
Rod End Style	Male, large	1
	Male, large, extended	1X
	Male, small (standard)	2
	Male, small, extended	2X
	◆ Male modified	2M
	Female	4
	◆ Female modified	4M
	Plain end	5
	Male, full rod diameter	6
	Male, for rod end coupling	10
	◆ Modified	M
	Ports	NPTF
SAE		S
Manifold		M
Flange		F
BSP/G		G
◆ Special		X
Rod Seals	Urethane Ultra-Seal	H
	Nitrile lip type	N
	Nitrile ELF rounded lip type	L
	PolyPak	P
	Viton PolyPak	F
	Viton lip type	V
	Ultra-Seal with scraper	J
	Nitrile lip type with scraper	S
	Viton PolyPak with scraper	G
	Viton lip type with scraper	U
	◆ Special	X
Piston Seals	Nitrile lip type	N
	Nitrile ELF rounded lip type	L
	Low friction PolyPak	D
	PolyPak	P
	Cast iron rings	R
	* Viton Lip Type	V
	Low breakaway Teflon radial seal with wearband	B
	◆ Special	X
Port Locations	Head End	1 thru 4
	◆ Special	X
Special Modifications	Cap End	1 thru 5
	◆ Special	X
Special Modifications	◆ Include ONLY if special modifications are required.	
	Air bleeders	Rod boots
	Drainbacks	Indicator switches
	Special seals	Four rod end flats
	Nonstd. mount	Port or cushion modifications
	Oversize ports	Double-end rod with different rod ends
	Bronze bushings	Special paint/plating
	Key Plate	
	Stainless steel rod	
	Stop Tube	

HOW TO ORDER

- Quantity
- Model number
- Special modifications if required
- Completed Application Data Sheet(s) (page 9) if required.
- Required ship date



HYDRO-LINE, INC.
ROCKFORD, IL

R5KD-3.25X8.00-N-1-2-N-N-N-1-1-X
194011234-1
A11579-375

Customer Number (if desired)
Hydro-Line Serial Number

R5KD - 3.25 X 8.00 - N - 1 - 2 - N - N - N - 1 - 1 - X



National
FLUID POWER
Association
MEMBER

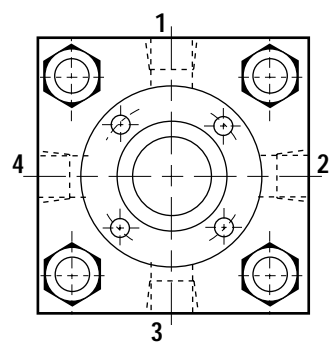

Port Locations
Port location 5 is on the center of the back face of the end cap.

◆ Include drawing or description
* If selected for high temperature, it should be specified to pin the piston to the rod.
● Urethane Ultra -Seal is standard on HA5 hydraulic

Hydro-Line Application Data Sheet

Company Name: _____ Contact: _____ Phone Number: _____ Fax Number: _____	Distributor Name: _____ Contact: _____ Phone Number: _____ Fax Number: _____
--	--

QUANTITY <input type="text"/> <input type="text"/> <input type="text"/> <input type="text"/>	Model Numbering System														
Model/Series	Mount	Bore	Stroke	Cushion	Rod Diameter	Rod End Style	Ports	Seals	Rod	Piston	Head	Cap	Model		
Double End Rod Style	Additional Rod Length	Needle Location	Keyplate	4-Flat	Bleeders	Bronze Bushing	Drain-back	Ind. Switch	Model Prefix						
<input type="text"/>	<input type="text"/>	C HEAD	<input type="text"/>	<input type="text"/>	<input type="text"/>	<input type="text"/>	<input type="text"/>	<input type="text"/>	<input type="text"/>						
Stop Tube Length	Trunnion XI Dimension			Stainless Steel Rod Type											
<input type="text"/>	<input type="text"/>	<input type="text"/>	<input type="text"/>	<input type="text"/>	<input type="text"/>	<input type="text"/>	<input type="text"/>	<input type="text"/>	<input type="text"/>						

Please fill in all available information above. Refer to the Hydro-Line Model Numbering System on Pages 2.

WHAT IS THE OPERATING ENVIRONMENT? <table style="width: 100%; font-size: x-small;"> <tr> <th style="width: 33%;">Fluid Media</th> <th style="width: 33%;">Operating Pressure</th> <th style="width: 33%;">Temperature at Cylinder</th> </tr> <tr> <td>Air _____</td> <td>Minimum _____ psi</td> <td>Minimum _____ °F</td> </tr> <tr> <td>Oil _____</td> <td>Typical _____ psi</td> <td>Typical _____ °F</td> </tr> <tr> <td>Other _____</td> <td>Maximum _____ psi</td> <td>Maximum _____ °F</td> </tr> <tr> <td colspan="3">Fluid Type _____</td> </tr> </table>	Fluid Media	Operating Pressure	Temperature at Cylinder	Air _____	Minimum _____ psi	Minimum _____ °F	Oil _____	Typical _____ psi	Typical _____ °F	Other _____	Maximum _____ psi	Maximum _____ °F	Fluid Type _____			WHAT IS THE WORK BEING PERFORMED? <table style="width: 100%; font-size: x-small;"> <tr> <th style="width: 33%;">Load</th> <th style="width: 33%;">Rod Speed</th> <th style="width: 33%;">Cycles per Minute</th> </tr> <tr> <td>Push _____ lbs.</td> <td>Extend _____ in./sec.</td> <td rowspan="2">_____ (in and out)</td> </tr> <tr> <td>Pull _____ lbs.</td> <td>Retract _____ in./sec.</td> </tr> </table>	Load	Rod Speed	Cycles per Minute	Push _____ lbs.	Extend _____ in./sec.	_____ (in and out)	Pull _____ lbs.	Retract _____ in./sec.
Fluid Media	Operating Pressure	Temperature at Cylinder																						
Air _____	Minimum _____ psi	Minimum _____ °F																						
Oil _____	Typical _____ psi	Typical _____ °F																						
Other _____	Maximum _____ psi	Maximum _____ °F																						
Fluid Type _____																								
Load	Rod Speed	Cycles per Minute																						
Push _____ lbs.	Extend _____ in./sec.	_____ (in and out)																						
Pull _____ lbs.	Retract _____ in./sec.																							

WHAT IS MOUNTING?			
Attitude		Rod End Connection	Known Side Load
Vertical _____	Angle _____	Firmly Guided _____	_____ lbs.
	Horizontal _____	Supported _____	
Rod Up _____	Degrees From Vertical _____	Unsupported _____	
Rod Down _____	Rod Up _____		
	Rod Down _____		

WHAT ENVIRONMENTAL CONDITIONS IS THE CYLINDER SUBJECTED TO?
Standard Factory _____ Corrosive Washdown _____ Chemical? _____ Outdoors _____ Other _____

WHAT IS THE PRESENT CYLINDER TYPE AND MODEL NUMBER?

WHAT IS THE PRESENT PROBLEM?

WHAT INDUSTRY IS THE CYLINDER USED IN?	WHAT TYPE OF MACHINE IS THE CYLINDER USED ON?	WHAT IS THE CYLINDER NAME THE APPLICATION?

APPLICATION SKETCH:	DESCRIPTION OF APPLICATION OR SPECIAL REQUIREMENT:

PREPARED BY: _____	DATE: _____	REVIEWED BY: _____	DATE: _____
CUSTOMER DRAWING NUMBER: _____	REVISION DATES: _____		HYDRO-LINE QUOTE NUMBER: _____

R5 and A5 Series Cylinder Types

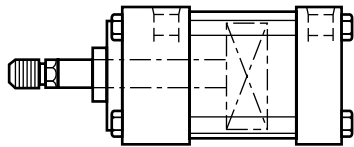

Single/Double Acting Cylinders

Standard R5 & A5 Series cylinders are double acting, with fluid power driving the piston in both directions. Single acting cylinders have fluid power driving the piston in one direction, relying on either the load or an external force to return the piston after the pressure is released.

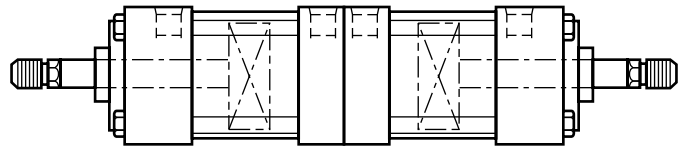

Back-to-Back Cylinders

Back-to-back cylinders are two single rod cylinders mounted together at the caps. Combinations of positions are possible through various combinations of piston actuation. Consult Hydro-Line for maximum operating pressure.

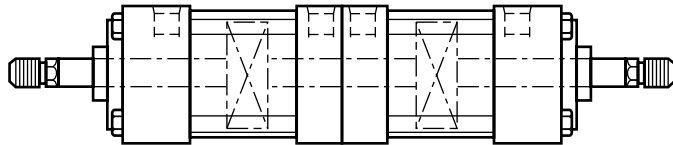

Double End Cylinders Back-to-Back

Double end cylinders mounted back-to-back have common piston rod and tie rods and the same stroke length. Consult Hydro-Line for maximum operating pressure.

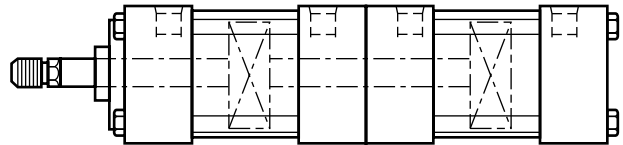

Tandem Cylinders

Tandem cylinders consist of two cylinders interconnected (piston and rod assemblies are connected). Pressure can act on two effective piston areas allowing the cylinder to be used as a force multiplier. This type of cylinder can also be used in air/oil systems to provide smooth, metered flow because of equal volumes in one chamber of both cylinders. Consult Hydro-Line for maximum operating pressure. **NOTE:** Front cylinder stroke is $\frac{1}{8}$ " longer at front cylinder when strokes are the same.

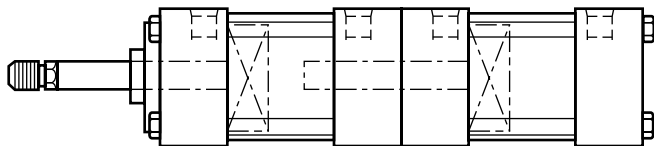

Multiple Position Cylinders

Multiple position cylinders are similar to tandem cylinders (except that the piston and rod assemblies are not connected) in that the output force is increased. Additionally, they may act as a precision multiple positioning device by actuating each cylinder successively or independently. Consult Hydro-Line for maximum operating pressure.

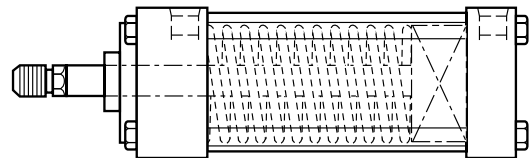

Spring Return/Extend Cylinders

Spring return/extend cylinders provide thrust in one direction only (can be either direction). One port is used for pressure to act against the load while the inactive port is vented. An internal spring is used to return the cylinder to its normal position.

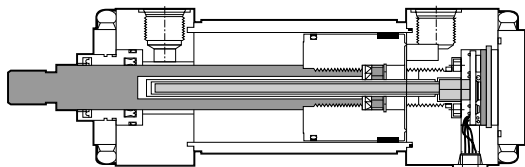

Systems Cylinders

Systems cylinders integrate position sensing and control valves to produce a complete servoactuator package. Hydro-Line's unique HLT In-Cylinder magnetostrictive feedback sensor provides a compact, robust package. External magnetostrictive (with protective covers) or internally mounted linear potentiometer transducers provide additional options. Valve, manifold blocks and a variety of servocontrol valves may be added to yield a complete control solution. (See Hydro-Line's Systems Catalog for more information.)

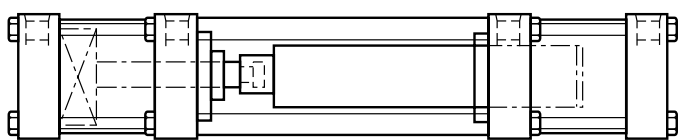

Pumping Units

Pumping units consist of a standard hydraulic cylinder coupled with a volume displacing lance cylinder via tie-bars. Special seals and lance surface treatments are available to provide compatibility with resins and chemicals used in the pumping process. Single and double ended designs are available.

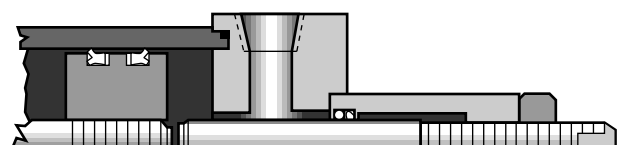

Adjustable Stroke Cylinders

Adjustable stroke cylinders are furnished with a stroke adjusting screw in the cap end of the cylinder. Adjusting this screw in or out limits the retract stroke to the precise length desired.

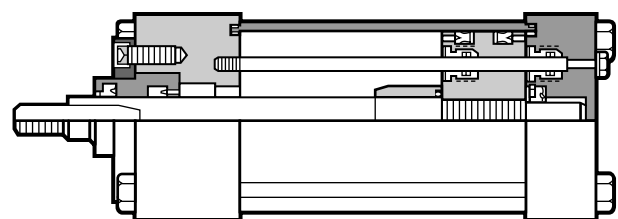

Non-Rotating Cylinders

Non-rotating cylinders are furnished with internal guide rods which prevent piston rod rotation throughout the stroke. Rotational torque and stroke length determine the amount and diameter of the guide rods.

R5 and A5 Series Mounting Application Data

Side and Center-Line Mountings

These mounts should be keyed or pinned to prevent shifting during operation. Keys or pins must be strong enough to resist the full thrust of the cylinder. The lugs on **A** and **H** mounts are large enough to accommodate dowel pins. Extended key plates for stock and custom cylinder models are available when specified. Pin or key the head whenever possible. Do not pin or key both ends. Cylinders become longer when pressure is applied and tube will tend to buckle.

The alignment and center-line height on the **E** mount are maintained by accurately machined surfaces on the head and cap which are held against the mounting surface by the end lugs.

DESCRIPTION	HYDRO-LINE MOUNT	NFPA DESIGNATION	R5 BORES AVAILABLE	A5 BORES AVAILABLE
Side Lugs	A	MS2	1"-20"	1 1/2"-6"
Side Tapped	B	MS4	1 1/2"-20"	1 1/2"-6"
Center-Line Lugs	H	MS3**	1 1/2"-20"	N/A
Side End Lugs	E	MS7	1 1/2"-14"	1 1/2"-6"

End and Intermediate Pivot Mountings

Trunnion and pivot pins are designed to carry shear loads only. Trunnion and pivot bearings must fit closely for the entire length of the pin. Hold the trunnion bearings rigidly and in accurate alignment.

DESCRIPTION	HYDRO-LINE MOUNT	NFPA DESIGNATION	R5 BORES AVAILABLE	A5 BORES AVAILABLE
Cap Fixed Clevis	C	MP1**	1"-20"	1 1/2"-6"
Detachable Clevis	DC	MP2	1 1/2"-6"	1 1/2"-6"
Head Trunnion	U	MT1**	1"-20"	1 1/2"-6"
Cap Trunnion	W	MT2**	1"-20"	1 1/2"-6"
Intermediate Fixed Trunnion	TT	MT4**	1 1/2"-14"	1 1/2"-6"

End Mountings

The head and cap rectangular mounts **G** and **P** should be used for hydraulic applications to avoid excessive deflection which occurs on the **F** and **R** mountings.

The **G**, **P**, **J** and **B** mounts are useable in both push and pull at full rated hydraulic pressures as shown on page 23.

On the following bore and rod combinations: 1" bore with 1/2" and 5/8" rod, 1 1/2" bore with 1" rod, 2" bore with 1 3/8" rod and 2 1/2" bore with 1 3/4" rod, the **G** mounting is not available. Use Head Rectangular Flange mounting **F** on pull applications and Cap Rectangular Flange mounting **R** on push applications for these sizes or mountings **J** and **S**.

DESCRIPTION	HYDRO-LINE MOUNT	NFPA DESIGNATION	R5 BORES AVAILABLE	A5 BORES AVAILABLE
Head Rectangular Flange	F	MF1	1"-6"	1 1/2"-6"
Cap Rectangular Flange	R	MF2	1"-6"	1 1/2"-6"
Head Square Flange	J	MF5	1"-6"	1 1/2"-6"
Cap Square Flange	S	MF6	1"-6"	1 1/2"-6"
Integral Square Head	G	**	8"-20"	N/A
Integral Square Cap	P	**	8"-20"	N/A
Tie Rods Extended	L, N, M	MX1, MX2, MX3	1"-20"	1 1/2"-6"
Head Rectangular	G	ME5**	1 1/2"-6"	N/A
Cap Rectangular	P	ME6**	1 1/2"-6"	N/A
No Mount	K	N/A	1"-20"	1 1/2"-6"

** NFPA mounting dimensions are available on all cylinders 1 1/2"-6" bore. For larger cylinders, see pages 18-21 for mounting dimensions.

Double Rod Cylinders

Double rod cylinders are available in all mountings except **C**, **DC**, **E**, **N**, **P**, **R**, **S** (with 2:1 rods, 1 1/2" through 2 1/2" bore) and **W**. Use the basic dimensional information on page 17 combined with dimensions in the drawings on pages 12-15.

Mounting Accessories

See pages 26-29 for mounting accessories.

R5 and A5 Series Mounting Dimensions

1" - 6" bore cylinders

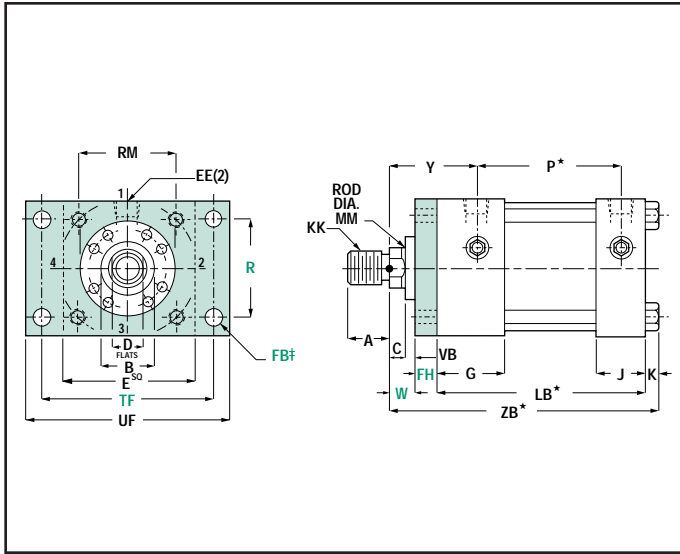

R5F & A5F – Head Rectangular Flange Mount (NFFA Style MF1)

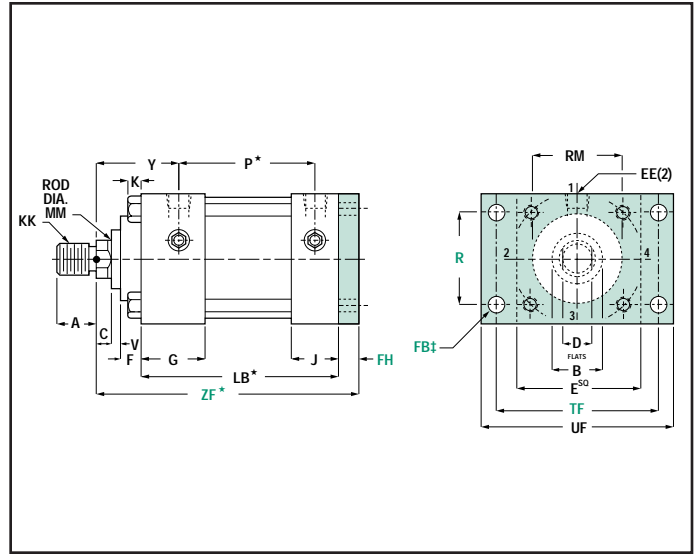

R5R & A5R – Cap Rectangular Flange Mount (NFFA Style MF2)

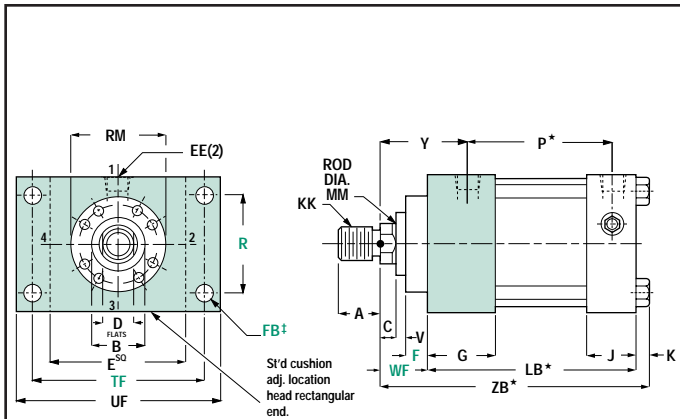

R5G – Head Rectangular Mount (NFFA Style ME5)

Not available on following sizes:

- 1" bore, 1/2" & 5/8" rod diameter
- 1 1/2" bore, 1" rod diameter
- 2" bore, 1 3/8" rod diameter
- 2 1/2" bore, 1 3/4" rod diameter

G-Mounting Retainer Dimensions

NOTE: Use the below chart for the cartridge retainer plate dimensions for the bore and rod combinations listed.

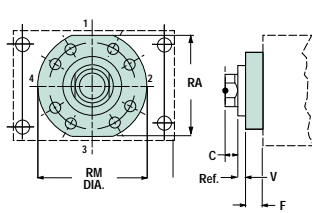

Not available on A5 Series

Bore	Rod Dia.	F	RA	RM	V
1 1/2	5/8	11/32	1.94	2 3/8	9/32
2	1	1/2	2.44	2 5/8	3/8
2 1/2	1 3/8	19/32	2.94	3 1/4	13/32
3 1/4	1 3/4	19/32	3.44	3 7/8	17/32
	2	19/32	3.69	4	17/32
4	2 1/2	19/32	-	4 7/16	21/32
	3	23/32	-	5 1/4	17/32
5	3 1/2	23/32	5.25	5 5/8	17/32

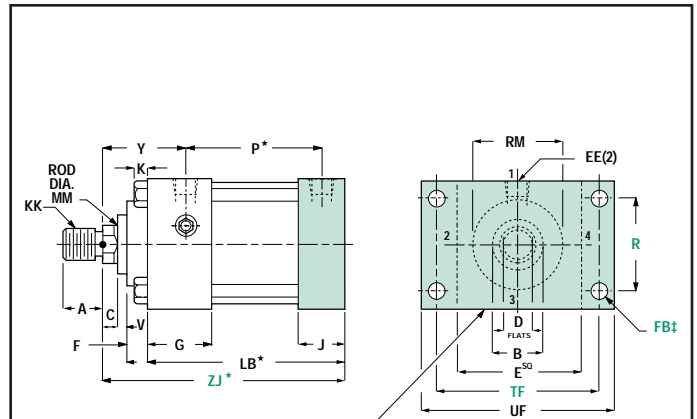

Not available on A5 Series

R5P – Cap Rectangular Mount (NFFA Style ME6)

* Mounting styles L and M use filler plate at the head end when cylinder has circular retainer.

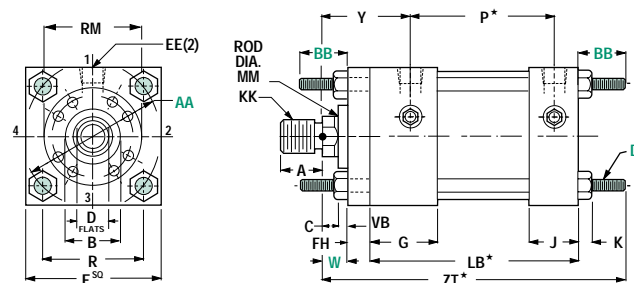

- (MX1) L – Both tie rods extended
- (MX3) M – Head end tie rods extended

R5L & M & A5L & M – Tie Rods Extended Mounts (NFFA Style MX1, MX3)

End Mountings

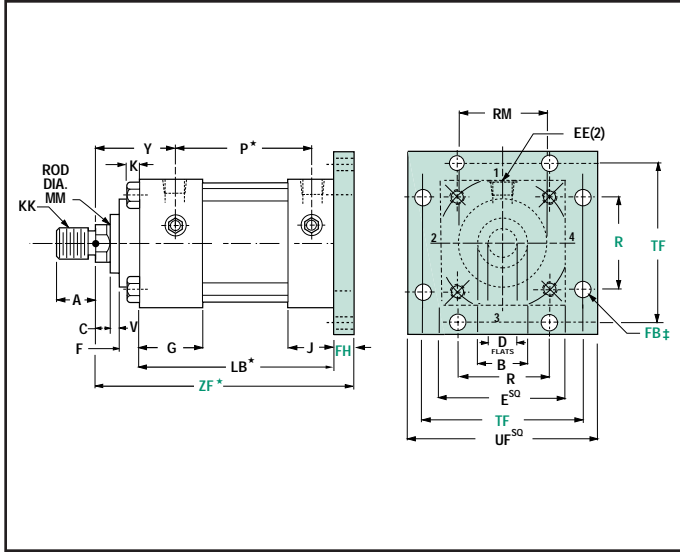

R5S & A5S – Cap Square Flange Mount (NFFA Style MF6)

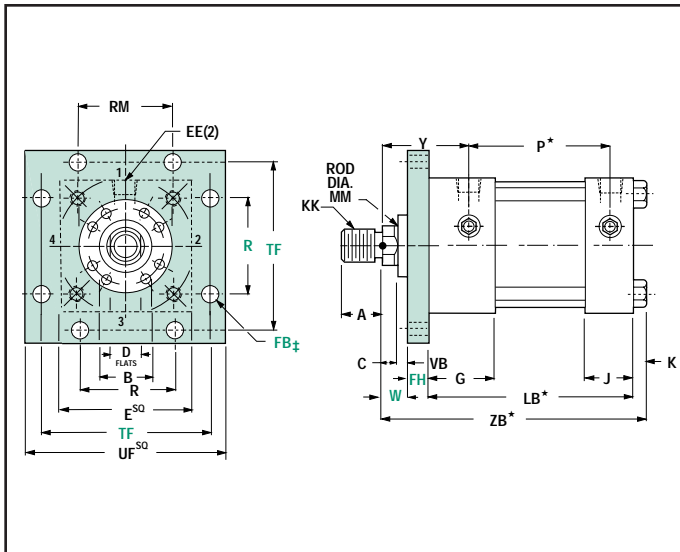

R5J & A5J – Head Square Flange Mount (NFFA Style MF5)

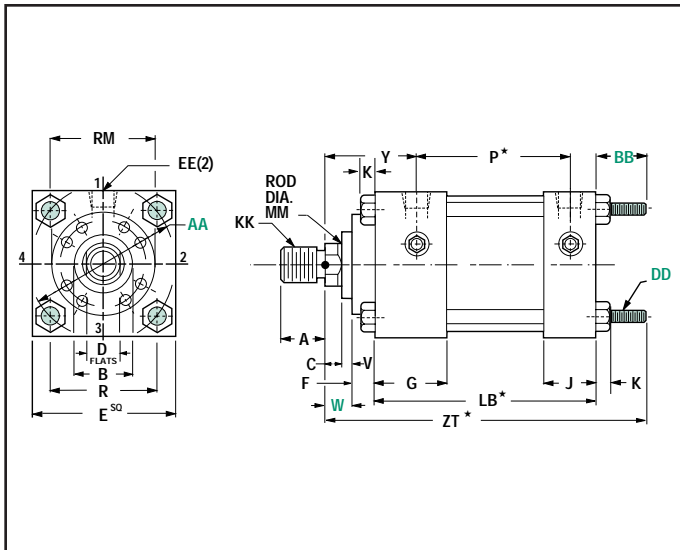

R5N & A5N – Cap End Tie Rods Extended Mounts (NFFA Style MX2)

Cylinder Dimensions

BORE	1*	1½	2	2½	3¼	4	5	6
A	5/8	3/4	3/4	3/4	1 1/8	1 1/8	1 1/8	1 5/8
AA	1.53	2.02	2.6	3.1	3.9	4.7	5.8	6.9
AC	N/A	1 1/8	1 1/8	1 1/8	1 1/2	1 1/2	1 1/2	1 3/4
AD	N/A	5/8	5/8	5/8	15/16	15/16	15/16	1 1/16
AE	N/A	1/4	1/4	1/4	3/8	3/8	3/8	3/8
AF	N/A	3/8	3/8	3/8	11/16	11/16	11/16	7/8
B -.001 -.003	1	1 1/8	1 1/8	1 1/8	1 1/2	1 1/2	1 1/2	2
BB	3/4	1	1 1/8	1 1/8	1 3/8	1 3/8	1 13/16	1 13/16
C	3/8	3/8	3/8	3/8	1/2	1/2	1/2	5/8
CC	7/16-20	1/2-20	1/2-20	1/2-20	7/8-14	7/8-14	7/8-14	1 1/4-12
D	3/8	17/32	17/32	17/32	7/8	7/8	7/8	1 1/8
DD	10-32	1/4-28	5/16-24	5/16-24	3/8-24	3/8-24	1/2-20	1/2-20
E	1 1/2	2	2 1/2	3	3 3/4	4 1/2	5 1/2	6 1/2
EE NPTF	1/4	3/8	3/8	3/8	1/2	1/2	1/2	3/4
EE SAE	#6	#6	#6	#6	#10	#10	#10	#12
F	▲	▲	▲	11/32	1/2	1/2	1/2	19/32
FB‡	1/4	5/16	3/8	3/8	7/16	7/16	9/16	9/16
FH	3/8	3/8	3/8	3/8	5/8	5/8	5/8	3/4
FT	1/2-20	5/8-18	5/8-18	5/8-18	1-14	1-14	1-14	1 3/8-12
G	1 1/2	1 1/2	1 1/2	1 1/2	1 3/4	1 3/4	1 3/4	2
J	1	1	1	1	1 1/4	1 1/4	1 1/4	1 1/2
K	3/16	1/4	5/16	5/16	3/8	3/8	7/16	7/16
KK	5/16-24	7/16-20	7/16-20	7/16-20	3/4-16	3/4-16	3/4-16	1-14
LB*	3 1/2	3 5/8	3 5/8	3 3/4	4 1/4	4 1/4	4 1/2	5
MM	1/2	5/8	5/8	5/8	1	1	1	1 3/8
P NPTF*	2 1/8	2 3/16	2 3/16	2 5/16	2 5/8	2 5/8	2 7/8	3 1/8
P SAE*	2 1/16	2 1/4	2 1/4	2 3/8	2 9/16	2 9/16	2 13/16	3 1/16
R	1.08	1.43	1.84	2.19	2.76	3.32	4.10	4.88
RM	§	§	§	2 3/8	2 5/8	2 5/8	2 5/8	3 1/4
TF	2	2 3/4	3 3/8	3 7/8	4 11/16	5 7/16	6 5/8	7 5/8
UF	2 1/2	3 3/8	4 1/8	4 5/8	5 1/2	6 1/4	7 5/8	8 5/8
V	▲	▲	▲	9/32	3/8	3/8	3/8	13/32
VB	1/4	1/4	1/4	1/4	1/4	1/4	1/4	1/4
W	5/8	5/8	5/8	5/8	3/4	3/4	3/4	7/8
WF	N/A	1	1	1	1 3/8	1 3/8	1 3/8	1 5/8
Y NPTF	1 15/16	1 31/32	1 31/32	1 31/32	2 7/16	2 7/16	2 7/16	2 13/16
Y SAE	1 31/32	1 31/32	1 31/32	1 31/32	2 7/16	2 7/16	2 7/16	2 13/16
ZB*	4 11/16	4 7/8	4 15/16	5 1/16	6	6	6 5/16	7 1/16
ZF*	4 7/8	5	5	5 1/8	6 1/4	6 1/4	6 1/2	7 3/8
ZJ*	N/A	4 5/8	4 5/8	4 3/4	5 5/8	5 5/8	5 7/8	6 5/8
ZT*	5 1/4	5 5/8	5 3/4	5 7/8	7	7	7 11/16	8 7/16

Dimensions shown in green are mounting dimensions.

NOTE: To determine piston thickness, subtract G and J dimensions from LB dimension.

NOTE: Additional port information on page 24.

■ Oversize rods affect dimensions in gray-shaded areas.

See pages 32-33 for these dimensions.

★ Add stroke to all starred dimensions.

§ Refer to Figure 5-1 on page 5.

NOTE: Overall length dimensions that require addition of stroke may vary from dimensions shown, due to manufacturing tolerances.

▲ Use FH dimension in place of F dimension and VB dimension in place of V dimension.

‡ Use screws 1/16" smaller than mounting holes.

◆ **NOTE:** On cushioned rod end 1 1/2" bore cylinders with one inch rod, a welded boss is required on rod end cap.

* A5 Series cylinders not available in 1" bore.

R5 and A5 Series Mounting Dimensions

1" – 6" bore cylinders

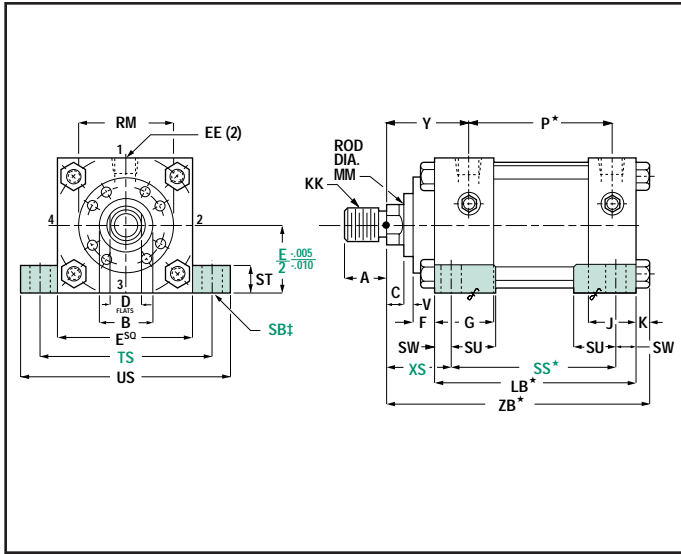

R5A & A5A – Side Lugs Mount (NFFA Style MS2)

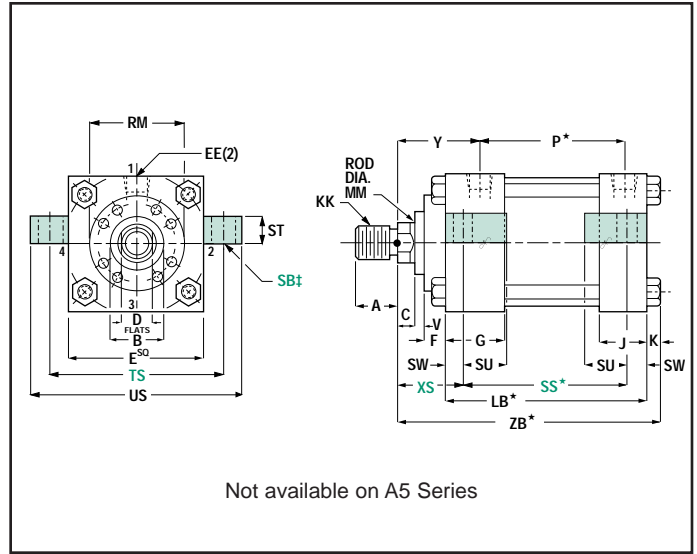

R5H – Center-Line Lugs Mount (NFFA Style MS3)
(Not available in 1" bore)

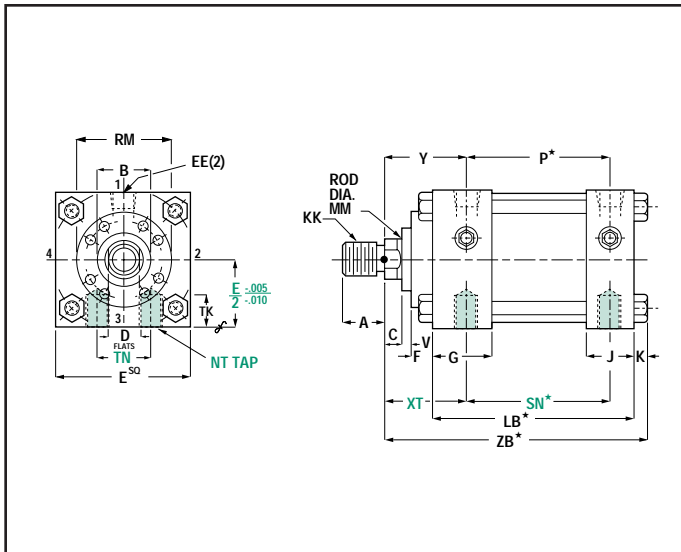

R5B & A5B – Side Tapped Mount (NFFA Style MS4)
(not available in 1" bore)

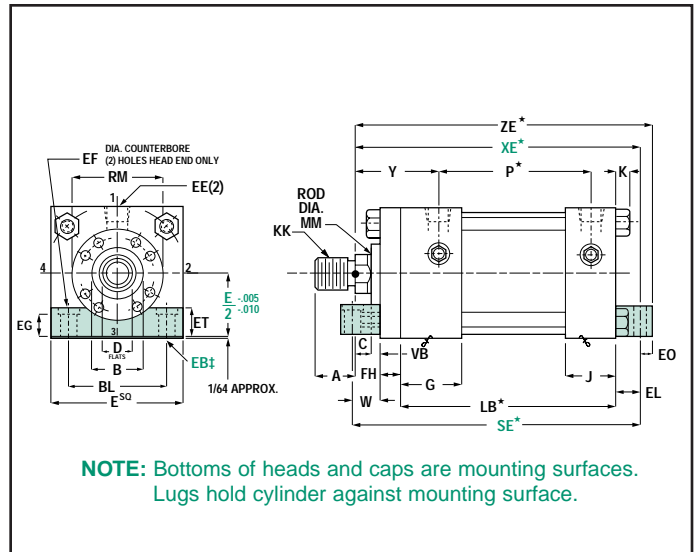

R5E & A5E – Side End Lugs (NFFA Style MS7)
(not available in 1" bore single rod or double rod and 1 1/2" through 2 1/2" bore double rod cylinders with 2:1 rod diameters.)

NOTE: Order Series R5 for air service; LR5 for pre-lubricated air service; HR5 for medium pressure hydraulic service by adding the desired series to the mounting style number. (Example: R5A or LR5A or HR5A.)

NOTE: To determine piston thickness, subtract G and J dimensions from LB dimension.

Side and Center-Line Mountings

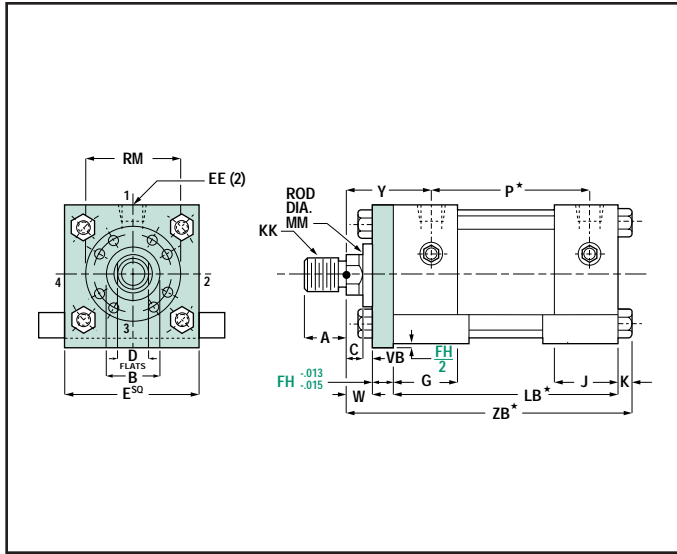

R5 & A5 – Extended Key Plate – Available when specified

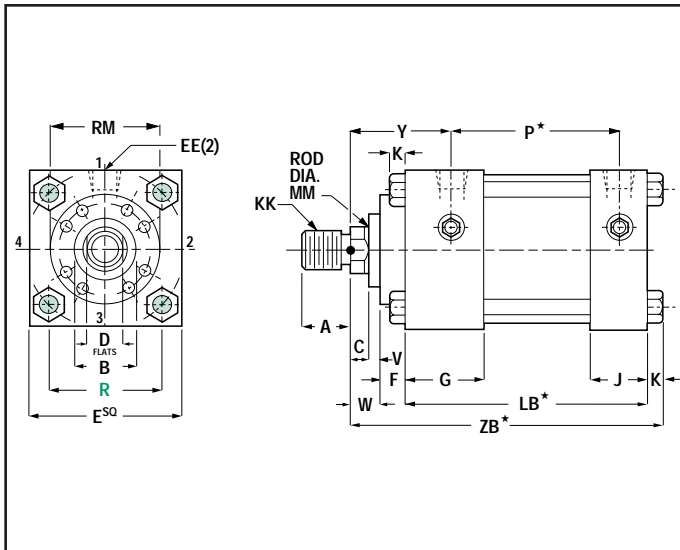

R5K & A5K – No Mount

Cylinder Dimensions

BORE	1*	1½	2	2½	3¼	4	5	6
A	5/8	3/4	3/4	3/4	11/8	11/8	11/8	15/8
AC	N/A	11/8	11/8	11/8	11/2	11/2	11/2	13/4
AD	N/A	5/8	5/8	5/8	15/16	15/16	15/16	11/16
AE	N/A	1/4	1/4	1/4	3/8	3/8	3/8	3/8
AF	N/A	3/8	3/8	3/8	11/16	11/16	11/16	7/8
B -.001 -.003	1	11/8	11/8	11/8	11/2	11/2	11/2	2
BL	1.08	1.43	1.84	2.19	2.76	3.32	4.10	4.88
C	3/8	3/8	3/8	3/8	1/2	1/2	1/2	5/8
CC	7/16-20	1/2-20	1/2-20	1/2-20	7/8-14	7/8-14	7/8-14	11/4-12
D	3/8	17/32	17/32	17/32	7/8	7/8	7/8	11/8
E	1½	2	2½	3	3¾	4½	5½	6½
EB†	N/A	5/16	3/8	3/8	7/16	7/16	9/16	9/16
EE NPTF	1/4	3/8	3/8	3/8	1/2	1/2	1/2	3/4
EE SAE #6	#6	#6	#6	#6	#10	#10	#10	#12
EF	N/A	1/2	1/2	1/2	N/A	N/A	7/8	7/8
EG	N/A	7/16	15/32	5/8	N/A	N/A	1¼	1¼
EL	N/A	3/4	15/16	11/16	7/8	1	11/16	1
EO	N/A	1/4	5/16	5/16	3/8	3/8	1/2	1/2
ET	N/A	9/16	¾	7/8	1	1¼	1½	15/8
F	▲	▲	▲	11/32	1/2	1/2	1/2	19/32
FH▲	3/8	3/8	3/8	3/8	5/8	5/8	5/8	3/4
FT	1/2-20	5/8-18	5/8-18	5/8-18	1-14	1-14	1-14	13/8-12
G	1½	1½	1½	1½	1¾	1¾	1¾	2
J	1	1	1	1	1¼	1¼	1¼	1½
K	3/16	1/4	5/16	5/16	3/8	3/8	7/16	7/16
KK	5/16-24	7/16-20	7/16-20	7/16-20	3/4-16	3/4-16	3/4-16	1-14
LB★	3½	35/8	35/8	3¾	4¼	4¼	4½	5
MM	1/2	5/8	5/8	5/8	1	1	1	13/8
NT	N/A	1/4-20	5/16-18	3/8-16	1/2-13	1/2-13	5/8-11	3/4-10
P NPTF★	21/8	23/16	23/16	25/16	25/8	25/8	27/8	31/8
P SAE★	21/16	2¼	2¼	23/8	29/16	29/16	213/16	31/16
RM	§	§	§	23/8	25/8	25/8	25/8	3¼
SB‡	9/32	7/16	7/16	7/16	9/16	9/16	13/16	13/16
SE★	N/A	5½	57/8	6¼	65/8	67/8	7¼	7¾
SN★	N/A	2¼	2¼	23/8	25/8	25/8	27/8	31/8
SS★	27/8	27/8	27/8	3	3¼	3¼	31/8	35/8
ST	5/16	1/2	1/2	1/2	3/4	3/4	1	1
SU	3/4	15/16	15/16	15/16	1¼	1¼	19/16	19/16
SW	5/16	3/8	3/8	3/8	1/2	1/2	11/16	11/16
TK	N/A	3/8	1/2	5/8	3/4	3/4	1	11/8
TN	N/A	5/8	7/8	1¼	1½	21/16	211/16	3¼
TS	21/8	23/4	3¼	3¾	4¾	5½	67/8	77/8
UF	2½	33/8	41/8	45/8	5½	6¼	75/8	85/8
US	2¾	3½	4	4½	5¾	6½	8¼	9¼
V	▲	▲	▲	9/32	3/8	3/8	3/8	13/32
VB▲	1/4	1/4	1/4	1/4	1/4	1/4	1/4	1/4
W	5/8	5/8	5/8	5/8	3/4	3/4	3/4	7/8
XE★	N/A	53/8	59/16	513/16	6½	65/8	615/16	75/8
XS	15/16	13/8	13/8	13/8	17/8	17/8	21/16	25/16
XT	N/A	115/16	115/16	115/16	27/16	27/16	27/16	213/16
Y NPTF	115/16	131/32	131/32	131/32	27/16	27/16	27/16	213/16
Y SAE	131/32	131/32	131/32	131/32	27/16	27/16	27/16	213/16
ZB★	411/16	47/8	415/16	51/16	6	6	65/16	71/16
ZE★	N/A	55/8	57/8	61/8	67/8	7	71/16	81/8

Dimensions shown in green are mounting dimensions.

NOTE: To determine piston thickness, subtract **G** and **J** dimension from **LB** dimension.

NOTE: Additional port information on page 24.

Gray shaded areas indicate oversized rods affect dimensions in gray-shaded areas.

See pages 32-33 for these dimensions.

★ Add stroke to all starred dimensions.

§ Refer to Figure 5-1 on page 5.

NOTE: Overall length dimensions that require addition of stroke may vary from dimensions shown, due to manufacturing tolerances.

▲ Use **FH** dimension in place of **F** dimension and **VB** dimension in place of **V** dimension.

‡ Use screws 1/16" smaller than mounting holes.

◆ **NOTE:** On cushioned rod end 1½" bore cylinders with one inch rod, a welded boss is required on rod end cap.

* A5 Series Cylinders not available in 1" bore.

R5 and A5 Series Mounting Dimensions

1" – 6" bore cylinders

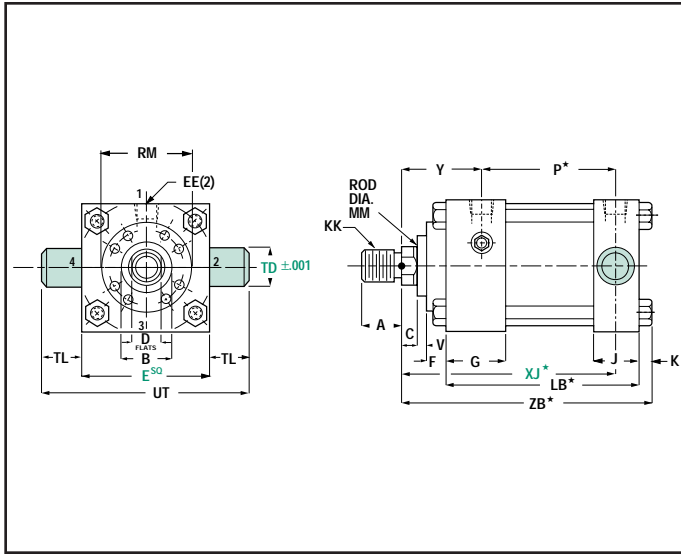

R5W & A5W – Cap Trunnion Mount (NFFPA Style MT2)

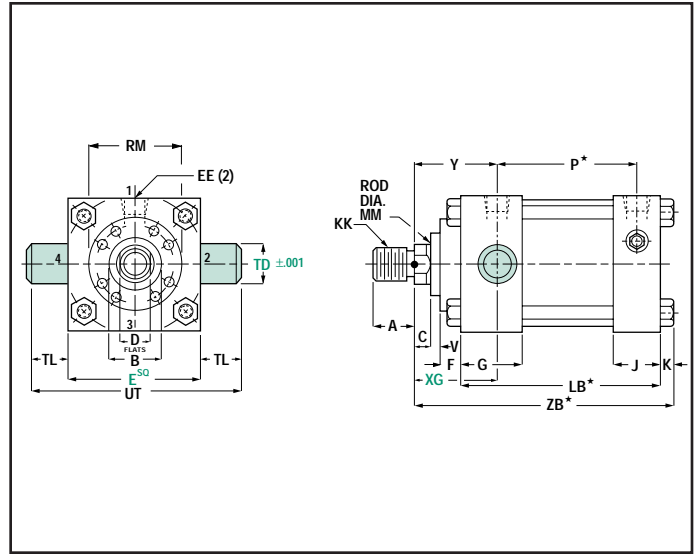

R5U & A5U – Head Trunnion Mount (NFFPA Style MT1)

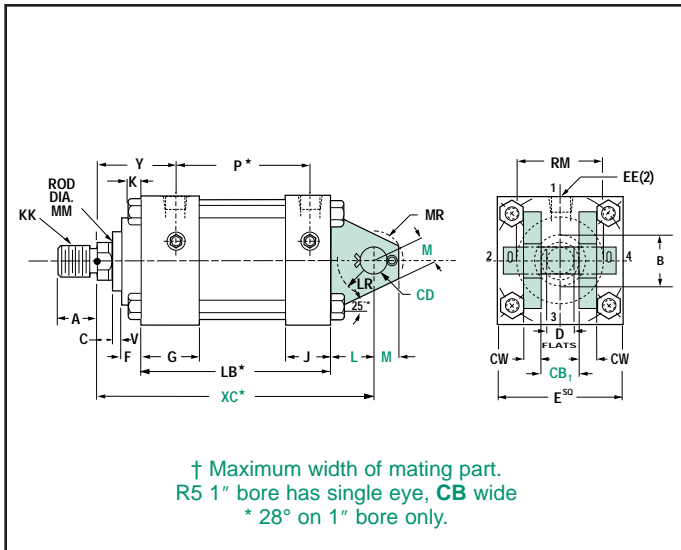

† Maximum width of mating part.
R5 1" bore has single eye, CB wide
* 28° on 1" bore only.

R5C & A5C – Cap Fixed Clevis Mount (NFFPA Style MP1)

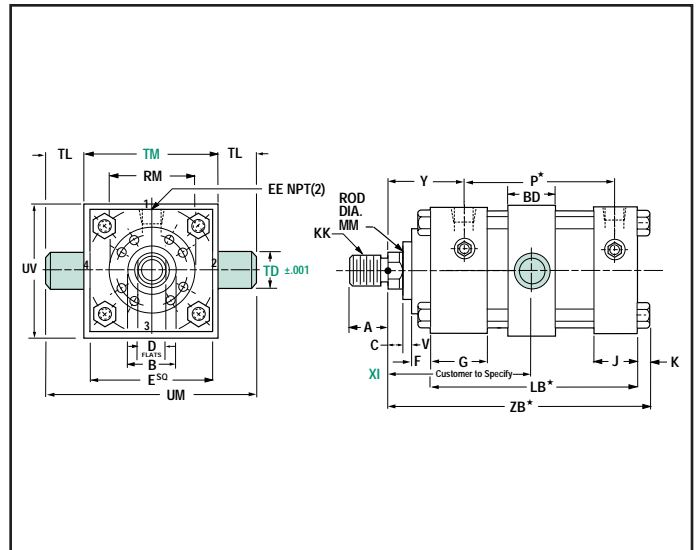

R5TT & A5TT – Intermediate Fixed Trunnion Mount (NFFPA Style MT4)
(not available in 1" bore)

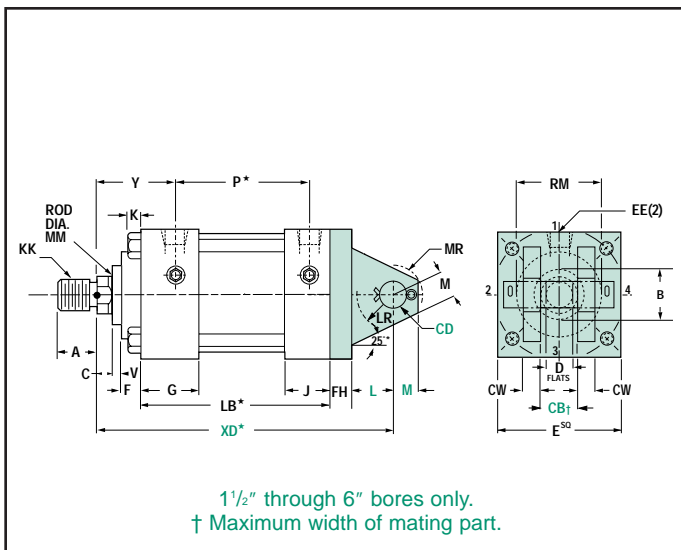

1 1/2" through 6" bores only.
† Maximum width of mating part.

R5DC & A5DC – Cap Detachable Clevis Mount (NFFPA Style MP2)

Pivot Mountings and Double Rod Cylinders

Cylinder Dimensions

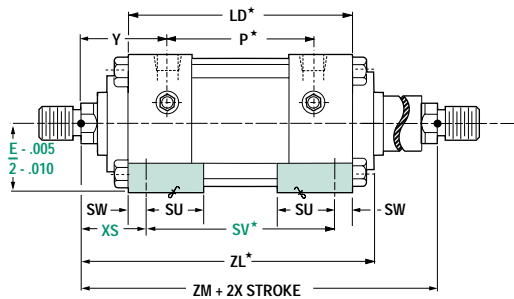

R5AD & A5AD – Side Lugs Mount – Double Rod

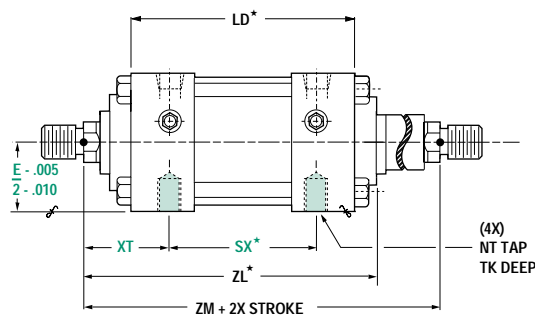

R5BD & A5BD – Side Tapped Mount – Double Rod

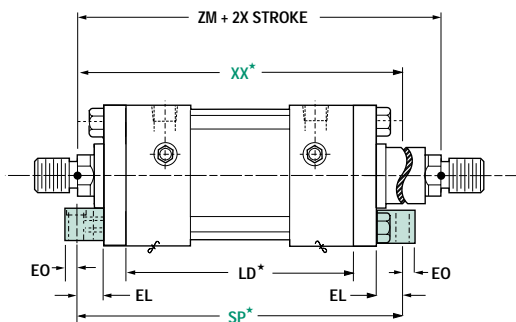

R5ED & A5ED – Side End Lugs Mount – Double Rod

- NOTE:** R5HD has mounting dimensions identical to R5AD.
- NOTE:** Add D for double end after the R5 series and mounting style. (Example: R5AD)
- NOTE:** Dimensions not shown are same as single rod cylinders.
- NOTE:** Double rod cylinders available in all mounts except C, DC, E (with 2:1 rods, 1 1/2" – 2 1/2" bore) and W.
- NOTE:** Order Series R5 or A5 for air service; LR5 or LA5 for prelubricated air service; HR5 or HA5 for medium pressure hydraulic service by adding the desired series to the mounting style number. (Example: R5A or LR5A or HR5A.)
- NOTE:** To determine piston thickness, subtract G and G dimensions from LD dimension.

BORE	*1	1 1/2	2	2 1/2	3 1/4	4	5	6
A	5/8	3/4	3/4	3/4	1 1/8	1 1/8	1 1/8	1 5/8
AC	N/A	1 1/8	1 1/8	1 1/8	1 1/2	1 1/2	1 1/2	1 3/4
AD	N/A	5/8	5/8	5/8	15/16	15/16	15/16	1 1/16
AE	N/A	1/4	1/4	1/4	3/8	3/8	3/8	3/8
AF	N/A	3/8	3/8	3/8	11/16	11/16	11/16	7/8
B ⁻⁰⁰¹ ⁻⁰⁰³	1	1 1/8	1 1/8	1 1/8	1 1/2	1 1/2	1 1/2	2
BD	N/A	1 1/4	1 1/2	1 1/2	2	2	2	2
C	3/8	3/8	3/8	3/8	1/2	1/2	1/2	5/8
CB†	7/16	3/4	3/4	3/4	1 1/4	1 1/4	1 1/4	1 1/2
CC	7/16-20	1/2-20	1/2-20	1/2-20	7/8-14	7/8-14	7/8-14	1 1/4-12
CD	7/16	1/2	1/2	1/2	3/4	3/4	3/4	1
CW	N/A	1/2	1/2	1/2	5/8	5/8	5/8	3/4
D	3/8	17/32	17/32	17/32	7/8	7/8	7/8	1 1/8
E	1 1/2	2	2 1/2	3	3 3/4	4 1/2	5 1/2	6 1/2
EE NPTF	1/4	3/8	3/8	3/8	1/2	1/2	1/2	3/4
EE SAE	#6	◆#6	#6	#6	#10	#10	#10	#12
EL	N/A	3/4	15/16	1 1/16	7/8	1	1 1/16	1
EO	N/A	1/4	5/16	5/16	3/8	3/8	1/2	1/2
F ▲	▲	▲	▲	1 1/32	1/2	1/2	1/2	19/32
FH▲	3/8	3/8	3/8	3/8	5/8	5/8	5/8	3/4
FT	1/2-20	5/8-18	5/8-18	5/8-18	1-14	1-14	1-14	1 3/8-12
G	1 1/2	1 1/2	1 1/2	1 1/2	1 3/4	1 3/4	1 3/4	2
J	1	1	1	1	1 1/4	1 1/4	1 1/4	1 1/2
K	3/16	1/4	5/16	5/16	3/8	3/8	7/16	7/16
KK	5/16-24	7/16-20	7/16-20	7/16-20	3/4-16	3/4-16	3/4-16	1-14
L	1/2	3/4	3/4	3/4	1 1/4	1 1/4	1 1/4	1 1/2
LB★	3 1/2	3 5/8	3 5/8	3 3/4	4 1/4	4 1/4	4 1/2	5
LD★	4	4 1/8	4 1/8	4 1/4	4 3/4	4 3/4	5	5 1/2
LR	15/32	9/16	9/16	9/16	1 1/16	1 1/16	1 1/16	1 5/16
M	7/16	1/2	1/2	1/2	3/4	3/4	3/4	1
MM	1/2	5/8	5/8	5/8	1	1	1	1 3/8
MR	17/32	9/16	9/16	9/16	1 1/16	1 1/16	1 1/16	1 1/8
P NPTF★	2 1/8	2 3/16	2 3/16	2 5/16	2 5/8	2 5/8	2 7/8	3 1/8
P SAE★	2 1/16	2 1/4	2 1/4	2 3/8	2 9/16	2 9/16	2 13/16	3 1/16
SP★	N/A	6 3/8	6 3/4	7 1/8	7 3/4	8	8 3/8	9
SU	3/4	15/16	15/16	15/16	1 1/4	1 1/4	1 9/16	1 9/16
SV★	3 3/8	3 3/8	3 3/8	3 1/2	3 3/4	3 3/4	3 5/8	4 1/8
SX★	N/A	2 1/4	2 1/4	2 3/8	2 5/8	2 5/8	2 7/8	3 1/8
RM	N/A	§	§	2 3/8	2 5/8	2 5/8	2 5/8	3 1/4
TD	3/4	1	1	1	1	1	1	1 3/8
TL	3/4	1	1	1	1	1	1	1 3/8
TM	N/A	2 1/2	3	3 1/2	4 1/2	5 1/4	6 1/4	7 5/8
UM	N/A	4 1/2	5	5 1/2	6 1/2	7 1/4	8 1/4	10 3/8
UT	3	4	4 1/2	5	5 3/4	6 1/2	7 1/2	9 1/4
UV	N/A	2 1/2	3	3 1/2	4 1/4	5	6	7
V	▲	▲	▲	9/32	3/8	3/8	3/8	13/32
VB▲	1/4	1/4	1/4	1/4	1/4	1/4	1/4	1/4
W	5/8	5/8	5/8	5/8	3/4	3/4	3/4	7/8
XC★	5	5 3/8	5 3/8	5 1/2	6 7/8	6 7/8	7 1/8	8 1/8
XD★	N/A	5 3/4	5 3/4	5 7/8	7 1/2	7 1/2	7 3/4	8 7/8
XG	1 3/4	1 3/4	1 3/4	1 3/4	2 1/4	2 1/4	2 1/4	2 5/8
XJ★	4	4 1/8	4 1/8	4 1/4	5	5	5 1/4	5 7/8
XS	1 5/16	1 3/8	1 3/8	1 3/8	1 7/8	1 7/8	2 1/16	2 5/16
XT	N/A	1 15/16	1 15/16	1 15/16	2 7/16	2 7/16	2 7/16	2 13/16
XX	N/A	6 1/4	6 7/16	6 1 1/16	7 5/8	7 3/4	8 1/16	8 7/8
Y NPTF	1 15/16	1 31/32	1 31/32	1 31/32	2 7/16	2 7/16	2 7/16	2 13/16
Y SAE	1 31/32	1 31/32	1 31/32	1 31/32	2 7/16	2 7/16	2 7/16	2 13/16
ZB★	4 1 1/16	4 7/8	4 15/16	5 1/16	6	6	6 5/16	7 1/16
ZL★	5 3/8	5 1/2	5 1/2	5 9/32	6 5/8	6 5/8	6 7/8	7 23/32
ZM★★	6	6 1/8	6 1/8	6 1/4	7 1/2	7 1/2	7 3/4	8 3/4

- NOTE:** Dimensions shown in green are mounting dimensions.
- NOTE:** To determine piston thickness, subtract G and J dimensions from LB dimension.
- NOTE:** Additional port information on page 24.
- NOTE:** Oversize rods affect dimensions in gray-shaded areas.
- NOTE:** See pages 32-33 for these dimensions
- ★ Add stroke to all starred dimensions.
- ★★ Plug 2x Stroke
- † Maximum width of mating part.
- § Refer to Figure 5-1 on page 5.

- NOTE:** Overall length dimensions that require addition of stroke may vary from dimensions shown, due to manufacturing tolerances.
- ▲ Use FH dimension in place of F dimension and VB dimension in place of V dimension.
- ‡ Use screws 1/16" smaller than mounting holes.
- ◆ **NOTE:** On cushioned rod end 1 1/2" bore cylinders with one inch rod, a welded boss is required on rod end cap.
- * A5 Series cylinders not available in 1" bore.

R5 Series Mounting Dimensions

8" – 20" bore cylinders

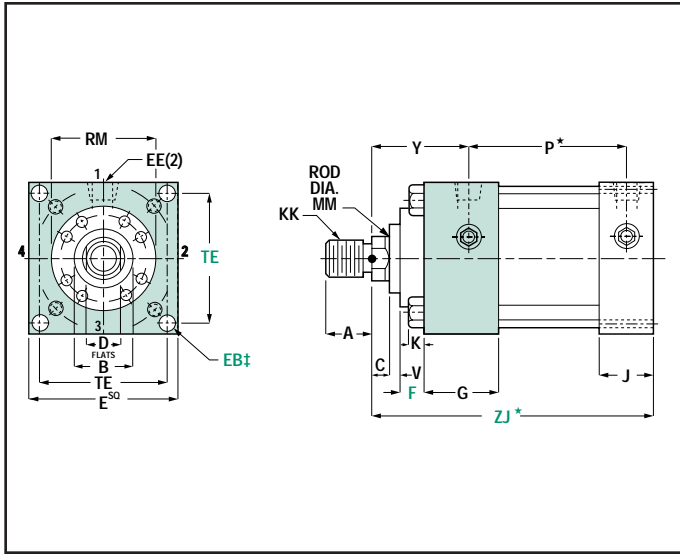

R5G – Head Square Mount (NFFPA Style ME3)

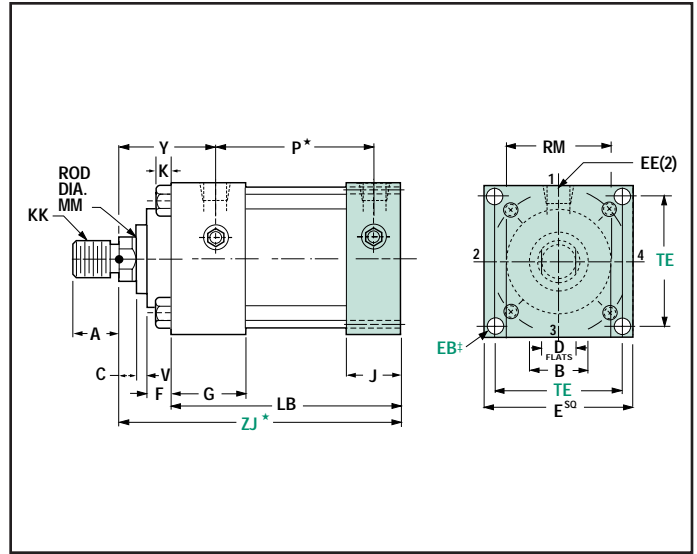

R5P – Cap Square Mount (NFFPA Style ME4)

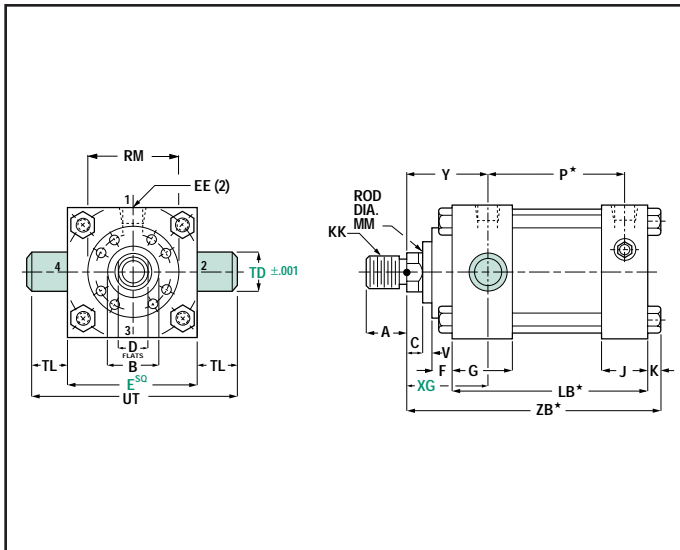

R5U – Head Trunnion Mount (NFFPA Style MT1)

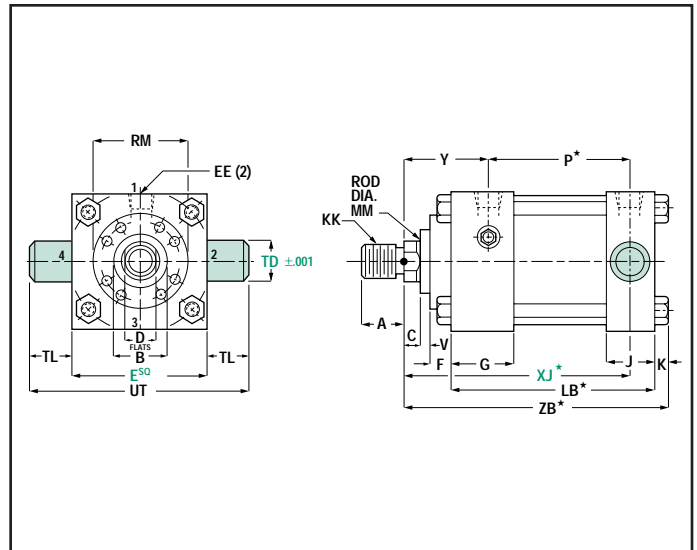

R5W – Cap Trunnion Mount (NFFPA Style MT2)

Tie Rod Information

To make torquing easier, and to permit use of standard size tools on large-bore cylinders, two tie rods are used at each corner of the 16, 18 and 20-inch bore sizes. This also reduces flexure of head and cap under pressure.

8, 10, 12, 14 bore tie rod configuration →

Dimensions shown in green are mounting dimensions.

NOTE: Order Series R5 for air service; LR5 for prelubricated air service; HR5 for medium pressure hydraulic service by adding the desired series to the mounting style number. (Example: R5A or LR5A or HR5A.)

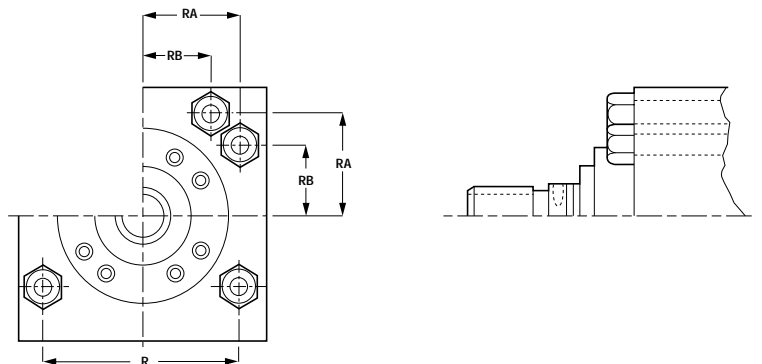

BORE	16"	18"	20"
RA	7.475	8.396	9.266
RB	5.234	5.879	6.488
TIE ROD THREAD	1-14	1 ¹ / ₈ -12	1 ¹ / ₄ -12

End and Pivot Mountings

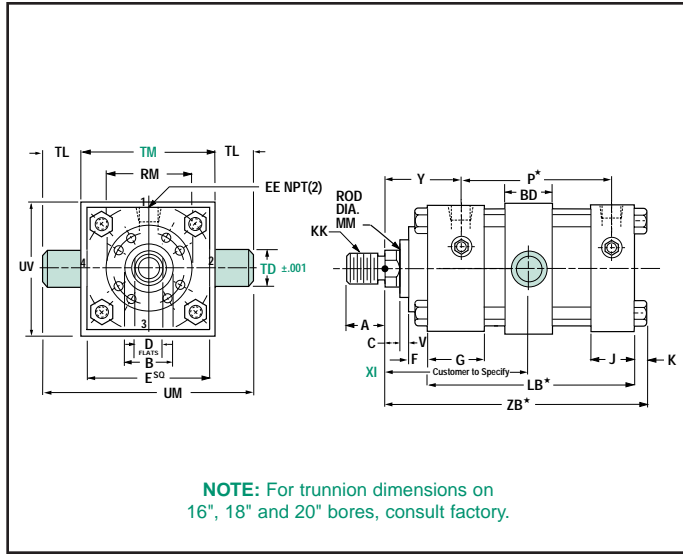

R5TT – Intermediate Fixed Trunnion Mount (NFPA Style MT4)

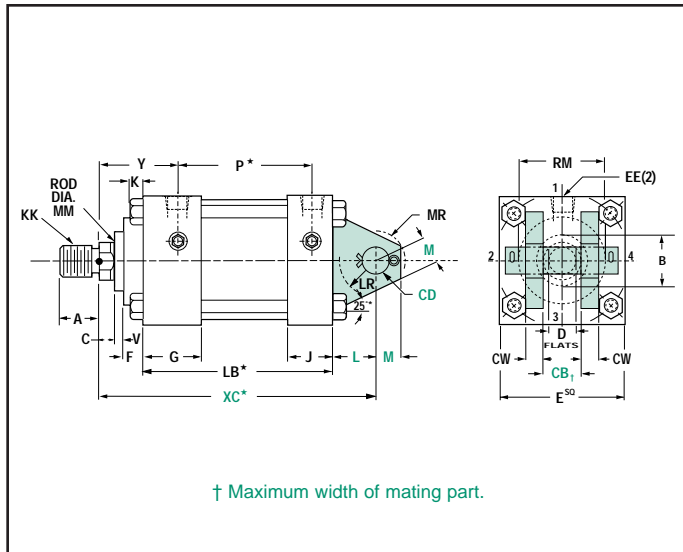

† Maximum width of mating part.

R5C – Cap Fixed Clevis Mount (NFPA Style MP1)

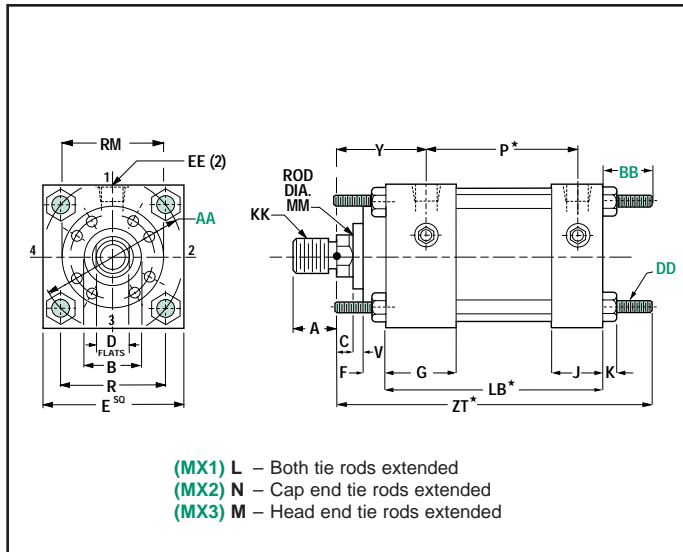

R5L, M, N – Tie Rods Extended Mounts (NFPA Style MX1, MX2, MX3)

Cylinder Dimensions

BORE	8	10	12	14	16	18	20
A	1 ⁵ / ₈	2	2 ¹ / ₄	3	3 ¹ / ₂	4	4
AA	9.1	11.2	13.3	15.4	18.25	20.50	22.62
AC	1 ³ / ₄	2	2 ⁵ / ₈	3 ¹ / ₄	4 ³ / ₈	4 ¹ / ₂	4 ¹ / ₂
AD	1 ¹ / ₁₆	1 ⁵ / ₁₆	1 ¹¹ / ₁₆	1 ¹⁵ / ₁₆	2 ¹ / ₁₆	2 ¹¹ / ₁₆	2 ¹¹ / ₁₆
AE	3 ⁸ / ₈	1 ² / ₂	5 ⁸ / ₈	3 ⁴ / ₄	1	1	1
AF	7 ⁸ / ₈	1 ¹ / ₈	1 ³ / ₈	1 ³ / ₄	2 ¹ / ₂	3	3
B -.001	2	2 ³ / ₈	2 ⁵ / ₈	3 ¹ / ₈	4 ¹ / ₄	4 ³ / ₄	4 ³ / ₄
B -.003	2 ⁵ / ₁₆	2 ¹¹ / ₁₆	2 ¹¹ / ₁₆	3 ³ / ₁₆	3 ⁵ / ₈	4 ¹ / ₈	4 ¹ / ₂
BB	2 ¹ / ₂	3	3	3 ¹ / ₂	N/A	N/A	N/A
BD	2 ¹ / ₂	3	3	3 ¹ / ₂	N/A	N/A	N/A
C	5 ⁸ / ₈	3 ⁴ / ₄	7 ⁸ / ₈	1	1	1	1
CB†	1 ¹ / ₂	2	2 ¹ / ₂	2 ¹ / ₂	3 ¹ / ₂	4	4
CC	1 ¹ / ₄ -12	1 ¹ / ₂ -12	1 ³ / ₄ -12	2 ¹ / ₄ -12	3 ¹ / ₄ -12	3 ³ / ₄ -12	3 ³ / ₄ -12
CD	1	1 ³ / ₈	1 ³ / ₄	2	2	2 ¹ / ₂	2 ¹ / ₂
CW	3 ⁴ / ₄	1	1 ¹ / ₄	1 ¹ / ₄	1 ³ / ₄	2	2
D	1 ¹ / ₈	1 ¹ / ₂	1 ³ / ₄	2 ¹ / ₈	3	▼	▼
DD	5 ⁸ / ₈ -18	3 ⁴ / ₄ -16	3 ⁴ / ₄ -16	7 ⁸ / ₈ -14	1-14	1 ¹ / ₈ -12	1 ¹ / ₄ -12
E	8 ¹ / ₂	10 ⁵ / ₈	12 ³ / ₄	14 ³ / ₄	17 ¹ / ₂	19 ¹ / ₂	21 ³ / ₄
EB‡	1 ¹ / ₁₆	1 ³ / ₁₆	1 ³ / ₁₆	1 ⁵ / ₁₆	1 ⁵ / ₁₆	1 ⁹ / ₁₆	1 ¹³ / ₁₆
EE NPTF	3 ⁴ / ₄	1	1	1 ¹ / ₄	1 ¹ / ₂	1 ¹ / ₂	2
EE SAE	#12	#16	#16	#20	#20	#24	#32
F	19 ³ / ₃₂	19 ³ / ₃₂	19 ³ / ₃₂	19 ³ / ₃₂	23 ³ / ₃₂	7 ⁸ / ₈	7 ⁸ / ₈
FB	1 ¹ / ₁₆	1 ³ / ₁₆	1 ³ / ₁₆	1 ⁵ / ₁₆	1 ⁵ / ₁₆	1 ⁹ / ₁₆	1 ¹³ / ₁₆
FT	1 ³ / ₈ -12	1 ³ / ₄ -12	2-12	2 ¹ / ₂ -12	3 ¹ / ₂ -12	4-12	4-12
G	2	2 ¹ / ₄	2 ¹ / ₄	2 ³ / ₄	2 ⁷ / ₈	3 ³ / ₈	3 ⁷ / ₈
J	1 ¹ / ₂	2	2	2 ¹ / ₄	2 ⁷ / ₈	3 ³ / ₈	3 ⁷ / ₈
K	9 ¹ / ₁₆	1 ¹ / ₁₆	1 ¹ / ₁₆	1 ³ / ₁₆	1 ⁵ / ₁₆	1	1 ¹ / ₈
KK	1-14	1 ¹ / ₄ -12	1 ¹ / ₂ -12	1 ⁷ / ₈ -12	2 ¹ / ₂ -12	3-12	3-12
L	1 ¹ / ₂	2 ¹ / ₈	2 ¹ / ₄	2 ¹ / ₂	3 ¹ / ₂	4 ¹ / ₄	4 ³ / ₄
LB★	5 ¹ / ₈	6 ³ / ₈	6 ⁷ / ₈	8 ¹ / ₈	9 ¹ / ₄	10 ¹ / ₄	11 ³ / ₄
LR	1 ³ / ₁₆	1 ¹³ / ₁₆	1 ¹⁵ / ₁₆	2 ³ / ₁₆	3	3 ³ / ₄	4 ¹ / ₄
M	1	1 ³ / ₈	1 ³ / ₄	2	2 ³ / ₄	3 ¹ / ₄	3 ³ / ₄
MM	1 ³ / ₈	1 ³ / ₄	2	2 ¹ / ₂	3 ¹ / ₂	4	4
MR	1 ¹ / ₈	1 ³ / ₄	1 ⁷ / ₈	2 ¹ / ₈	2 ³ / ₄	3 ¹ / ₄	3 ³ / ₄
P NPTF★	3 ¹ / ₄	4 ¹ / ₈	4 ⁵ / ₈	5 ¹ / ₂	6 ¹ / ₂	6 ¹ / ₂	7 ³ / ₈
P SAE★	3 ¹ / ₄	3 ¹⁵ / ₁₆	4 ⁷ / ₁₆	5 ¹ / ₄	5 ⁷ / ₈	6 ¹ / ₄	7 ¹ / ₄
R	6.44	7.92	9.40	10.90	§	§	§
RM	3 ¹ / ₄	3 ⁷ / ₈	4	4 ⁷ / ₁₆	5 ⁵ / ₈	6 ⁷ / ₁₆	6 ⁷ / ₁₆
TD	1 ³ / ₈	1 ³ / ₄	1 ³ / ₄	2	N/A	N/A	N/A
TE	7.57	9.40	11.10	12.87	14.75	16.50	18.25
TL	1 ³ / ₈	1 ³ / ₄	1 ³ / ₄	2	2 ³ / ₄	3	3 ¹ / ₂
TM	9 ³ / ₄	12	14	16 ¹ / ₄	N/A	N/A	N/A
UM	12 ¹ / ₂	15 ¹ / ₂	17 ¹ / ₂	20 ¹ / ₄	N/A	N/A	N/A
UT	11 ¹ / ₄	14 ¹ / ₈	16 ¹ / ₄	18 ³ / ₄	23	25 ¹ / ₂	28 ³ / ₄
UV	9 ¹ / ₂	11 ³ / ₄	13 ³ / ₄	16	N/A	N/A	N/A
V	13 ³ / ₃₂	17 ³ / ₃₂	17 ³ / ₃₂	21 ³ / ₃₂	17 ³ / ₃₂	3 ⁸ / ₈	3 ⁸ / ₈
WF	1 ⁵ / ₈	1 ⁷ / ₈	2	2 ¹ / ₄	2 ¹ / ₄	2 ¹ / ₄	2 ¹ / ₄
XC★	8 ¹ / ₄	10 ³ / ₈	11 ¹ / ₈	12 ⁷ / ₈	15	16 ³ / ₄	18 ³ / ₄
XG	2 ⁵ / ₈	3	3 ¹ / ₈	3 ⁵ / ₈	3 ¹¹ / ₁₆	3 ¹⁵ / ₁₆	4 ³ / ₁₆
XI	CUSTOMER TO SPECIFY						
XJ★	6	7 ¹ / ₄	7 ⁷ / ₈	9 ¹ / ₄	10 ¹ / ₁₆	10 ¹³ / ₁₆	12 ¹ / ₁₆
Y NPTF	2 ¹³ / ₁₆	3 ¹ / ₈	3 ¹ / ₄	3 ³ / ₁₆	3 ⁵ / ₈	4 ¹ / ₈	4 ⁷ / ₁₆
Y SAE	2 ¹³ / ₁₆	3 ⁷ / ₃₂	3 ¹¹ / ₃₂	3 ¹⁵ / ₁₆	3 ¹⁵ / ₁₆	4 ¹ / ₄	4 ¹ / ₂
ZB★	7 ⁵ / ₁₆	8 ¹⁵ / ₁₆	9 ⁹ / ₁₆	11 ³ / ₁₆	12 ⁷ / ₁₆	13 ¹ / ₂	15 ¹ / ₈
ZJ★	6 ³ / ₄	8 ¹ / ₄	8 ⁷ / ₈	10 ³ / ₈	11 ¹ / ₂	12 ¹ / ₂	14
ZT★	9 ¹ / ₁₆	10 ¹⁵ / ₁₆	11 ⁹ / ₁₆	13 ⁹ / ₁₆	15 ¹ / ₈	16 ⁵ / ₈	18 ¹ / ₂

Dimensions shown in green are mounting dimensions.

NOTE: To determine piston thickness, subtract G and J dimensions from LB dimension.

Overdose rods affect dimensions in gray-shaded areas. See pages 32-33 for these dimensions.

★ Add stroke to all starred dimensions.

‡ Use screws 1/16" smaller than mounting holes.

▼ (4) spanner holes used instead of flats on 4" diameter and larger.

§ See tie rod information on page 18.

NOTE: Overall length dimensions that require addition of stroke may vary from dimensions shown, due to manufacturing tolerances.

R5 Series Mounting Dimensions

8" – 20" bore cylinders

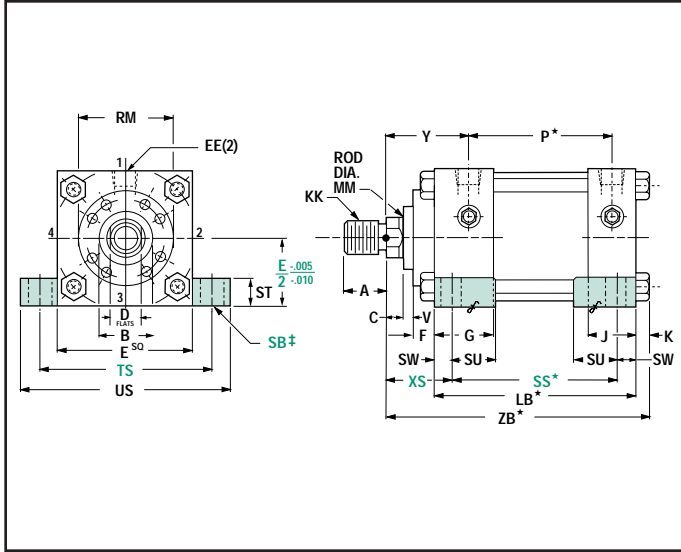

R5A – Side Lugs Mount (NFFA Style MS2)

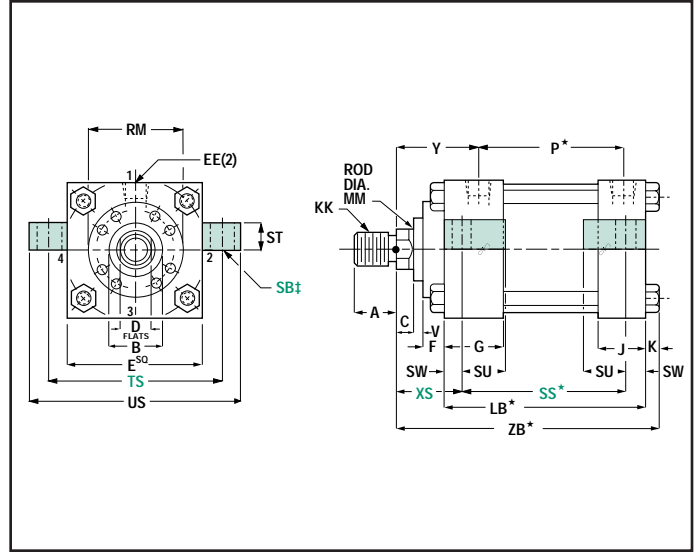

R5H – Center-Line Lugs Mount (NFFA Style MS3)

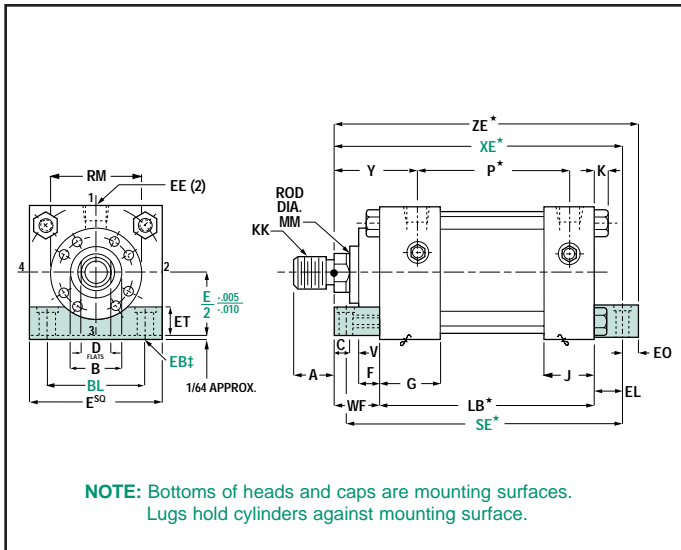

NOTE: Bottoms of heads and caps are mounting surfaces.
Lugs hold cylinders against mounting surface.

R5E – Side End Lugs Mount (NFFA Style MS7)
(not available in 16" - 20" bores)

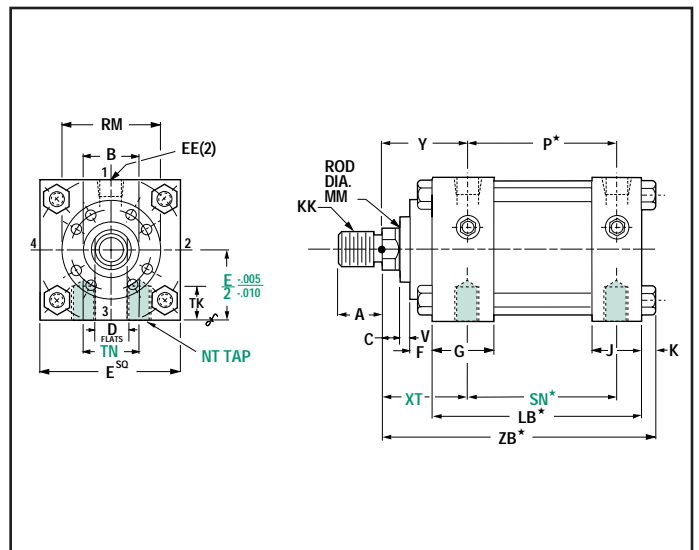

R5B – Side Tapped Mount (NFFA Style MS4)

Side, Center-Line Mountings and Double Rod Cylinders

Cylinder Dimensions

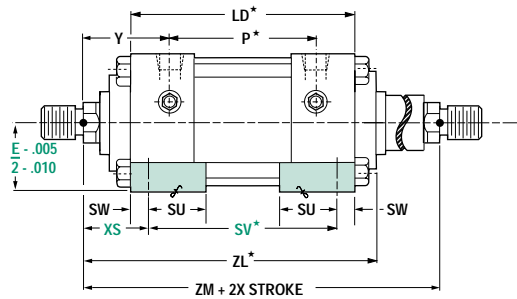

R5AD – Side Lugs Mount – Double Rod

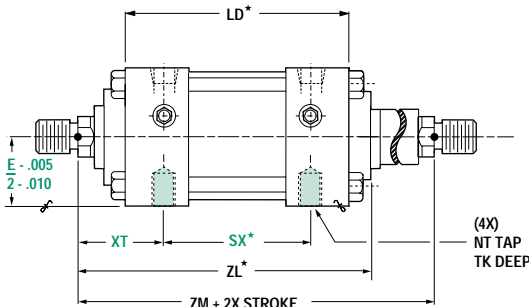

R5BD – Side Tapped Mount – Double Rod

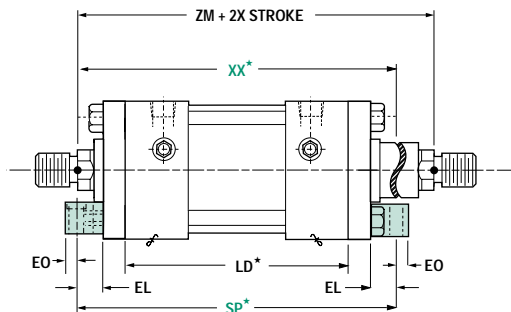

R5ED – Side End Lugs Mount – Double Rod

- NOTE:** R5HD has mounting dimensions identical to R5AD.
- NOTE:** Add **D** for double end after the R5 series and mounting style.
(Example: R5AD)
- NOTE:** Dimensions not shown are same as single rod cylinders.
- NOTE:** Double rod cylinders available in all mounts except **C**, **DC** and **W**.
- NOTE:** Order Series R5 for air service; LR5 for prelubricated air service; HR5 for medium pressure hydraulic service by adding the desired series to the mounting style number.
(Example: R5A or LR5A or HR5A.)
- NOTE:** To determine piston thickness, subtract **G** and **G** dimensions from **LD** dimension.

BORE	8	10	12	14	16*	18*	20*
A	15/8	2	2 1/4	3	3 1/2	4	4
AC	1 3/4	2	2 5/8	3 1/4	4 3/8	4 1/2	4 1/2
AD	1 1/16	1 5/16	1 11/16	1 15/16	2 11/16	2 11/16	2 11/16
AE	3/8	1/2	5/8	3/4	1	1	1
AF	7/8	1 1/8	1 3/8	1 3/4	2 1/2	3	3
B ⁻⁰⁰¹ ⁻⁰⁰³	2	2 3/8	2 5/8	3 1/8	4 1/4	4 3/4	4 3/4
BL	6.44	7.92	9.40	10.90	N/A	N/A	N/A
C	5/8	3/4	7/8	1	1	1	1
CC	1 1/4-12	1 1/2-12	1 3/4-12	2 1/4-12	3 1/4-12	3 3/4-12	3 3/4-12
D	1 1/8	1 1/2	1 3/4	2 1/8	3	▼	▼
E	8 1/2	10 5/8	12 3/4	14 3/4	17 1/2	19 1/2	21 3/4
EB‡	11/16	13/16	13/16	15/16	N/A	N/A	N/A
EE NPTF	3/4	1	1	1 1/4	1 1/2	1 1/2	2
EE SAE	#12	#16	#16	#20	#20	#24	#32
EL	1 1/8	1 5/16	1 5/16	1 1/2	N/A	N/A	N/A
EO	5/8	5/8	5/8	3/4	N/A	N/A	N/A
ET	2	2 3/4	3 7/16	3 7/8	N/A	N/A	N/A
F	19/32	19/32	19/32	19/32	23/32	7/8	7/8
FT	1 3/8-12	1 3/4-12	2-12	2 1/2-12	3 1/2-12	4-12	4-12
G	2	2 1/4	2 1/4	2 3/4	2 7/8	3 3/8	3 7/8
J	1 1/2	2	2	2 1/4	2 7/8	3 3/8	3 7/8
K	9/16	1 1/16	1 1/16	1 3/16	1 5/16	1	1 1/8
KK	1-14	1 1/4-12	1 1/2-12	1 7/8-12	2 1/2-12	3-12	3-12
LB★	5 1/8	6 3/8	6 7/8	8 1/8	9 1/4	10 1/4	11 3/4
LD★	5 5/8	6 5/8	7 1/8	8 5/8	9 1/4	10 1/4	11 3/4
MM	1 3/8	1 3/4	2	2 1/2	3 1/2	4	4
NT	3/4-10	1-8	1-8	1 1/4-7	1 3/4-12	2-12	2 1/4-12
P NPTF★	3 1/4	4 1/8	4 5/8	5 1/2	6 1/2	6 1/2	7 3/8
P SAE★	3 3/16	3 15/16	4 7/16	5 1/4	5 7/8	6 1/4	7 1/4
RM	3 1/4	3 7/8	4	4 7/16	5 5/8	6 7/16	6 7/16
SB‡	13/16	1 1/16	1 1/16	1 5/16	1 13/16	2 1/16	2 5/16
SE★	7 3/8	9	9 1/2	11 1/8	N/A	N/A	N/A
SN★	3 1/4	4 1/8	4 5/8	5 1/2	6 1/2	7	7 3/4
SP★	7 7/8	9 1/4	9 3/4	11 5/8	N/A	N/A	N/A
SS★	3 3/4	4 5/8	5 1/8	5 7/8	5 3/4	6 1/4	7
ST	1	1 1/4	1 1/4	1 1/2	2	2 1/2	3
SU	1 9/16	2	2	2 1/2	3 1/2	3 1/2	3 5/8
SV★	4 1/4	4 7/8	5 3/8	6 3/8	5 3/4	6 1/4	7
SX★	3 1/4	4 1/8	4 5/8	5 1/2	6 1/2	7	7 3/4
SW	1 1/16	7/8	7/8	1 1/8	1 3/4	2	2 3/8
TK	1 1/8	1 1/2	1 1/2	1 7/8	3	3 1/4	3 3/4
TN	4 1/2	5 1/2	7 1/4	8 3/8	7	8	8 1/2
TS	9 7/8	12 3/8	14 1/2	17	21	23 1/2	26 1/2
US	11 1/4	14 1/8	16 1/4	19 1/4	24 1/4	27 1/2	31 1/4
V	13/32	17/32	17/32	21/32	17/32	3/8	3/8
WF	1 5/8	1 7/8	2	2 1/4	2 1/4	2 1/4	2 1/4
XE★	7 7/8	9 9/16	10 3/16	11 7/8	N/A	N/A	N/A
XS	2 5/16	2 3/4	2 7/8	3 3/8	4	4 1/4	4 5/8
XT	2 13/16	3 1/8	3 1/4	3 13/16	3 11/16	3 15/16	4 3/16
XX★	8 3/8	9 13/16	10 7/16	12 3/8	N/A	N/A	N/A
Y NPTF	2 13/16	3 1/8	3 1/4	3 13/16	3 5/8	4 1/8	4 7/16
Y SAE	2 13/16	3 7/32	3 11/32	3 15/16	3 15/16	4 1/4	4 1/2
ZB★	7 5/16	8 15/16	9 9/16	11 3/16	12 7/16	13 1/2	15 1/8
ZE★	8 1/2	10 3/16	10 13/16	12 5/8	N/A	N/A	N/A
ZL★	7 27/32	9 3/32	9 23/32	11 15/32	12 7/32	13 3/8	14 7/8
ZM	8 7/8	10 3/8	11 1/8	13 1/8	13 3/4	14 3/4	16 1/4

- Dimensions shown in green are mounting dimensions.
- NOTE:** To determine piston thickness, subtract **G** and **J** dimensions from **LD** dimension.
- NOTE:** Additional port information on page 24.
- Oversize rods affect dimensions in gray-shaded areas.
See pages 32-33 for these dimensions.
- ★ Add stroke to all starred dimensions.
- Mounting **E** not available in these sizes.
- NOTE:** Overall length dimensions that require addition of stroke may vary from dimensions shown, due to manufacturing tolerances.
- § See tie rod information on page 18
- ‡ Use screws 1/16" smaller than mounting holes.
- ▼ (4) Spanner holes used instead of flats on 4" diameter and larger.
- NOTE:** The interchangeability of the 16", 18" and 20" bores with other brands has not been established by the NFPA

The above dimensions are Hydro-Line standards.

Hydro-Line Technical Data

Rod Size And Stop Tube Selection

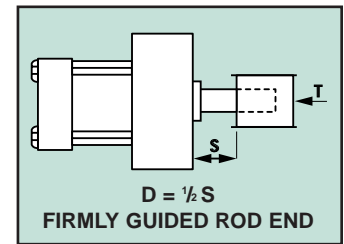
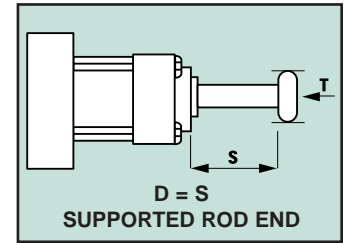
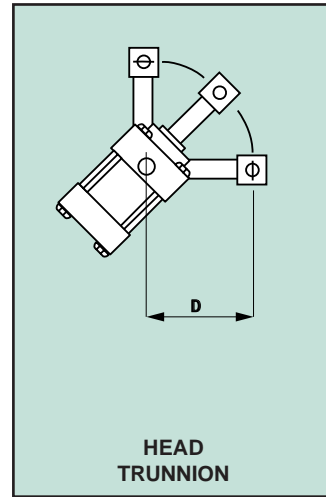
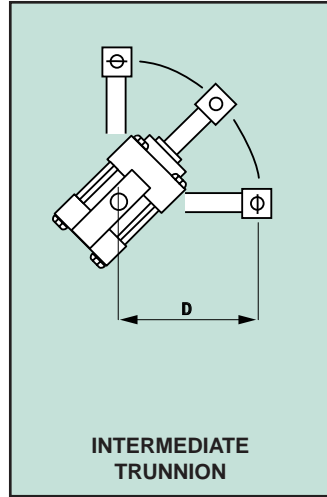
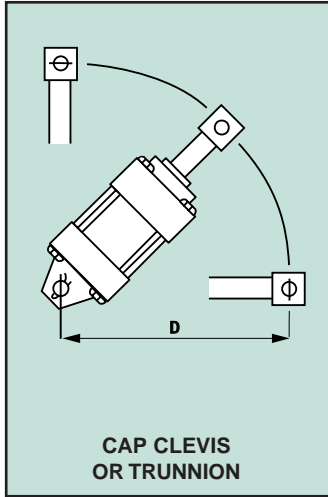
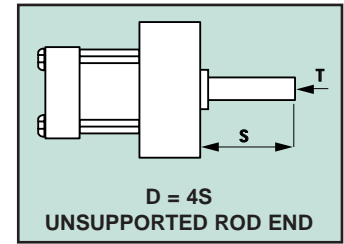
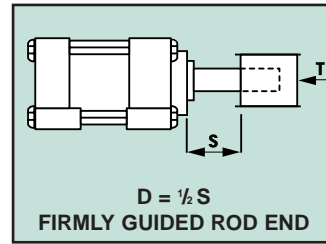
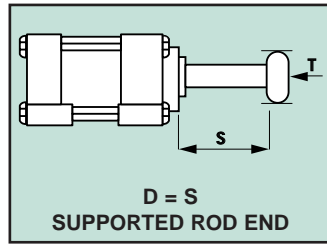
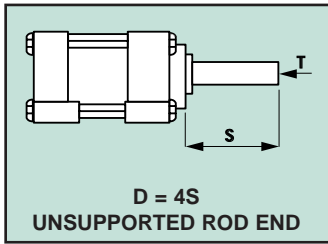

Rod Size Selection:

Standard rod sizes are normally suitable for all applications except for long stroke or high thrust applications. Proper selection of minimum rod size may be determined by the following steps:

1. With knowledge of bore size and operating pressure, thrust may be determined. Refer to the graph in the next column.
2. Select from illustrations above the type of mounting to be used and determine the length of D with the piston rod in the fully extended position.
3. Find the value of D at the bottom of the graph and follow its line vertically until it intercepts the horizontal line representing the maximum push thrust that will be applied to your cylinder. The intersection of these two lines will fall within a stripe representing the minimum recommended piston rod diameter for your application.

Stop Tubes:

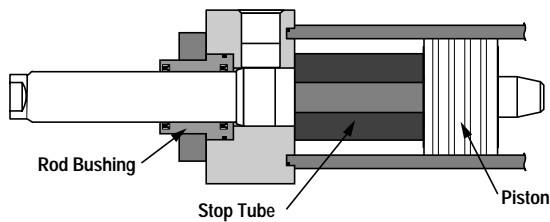

Stop tubes are located between the piston and the rod shoulder on the head end of the cylinder. Bearing loading is reduced by separating the piston and the rod bushing. Bearing wear and tendency to buckle is reduced.

To determine if a stop tube is required and the length of stop tube needed, use the following procedure:

Determine the value of D with the piston rod in the fully extended position. If the value of D is under 40", no stop tube is needed. If D is greater than 40", one inch of stop tube is recommended for each 10" or fraction thereof beyond 40".

Special note: When specifying stroke and stop tube lengths, please include net working stroke plus stop tube length.

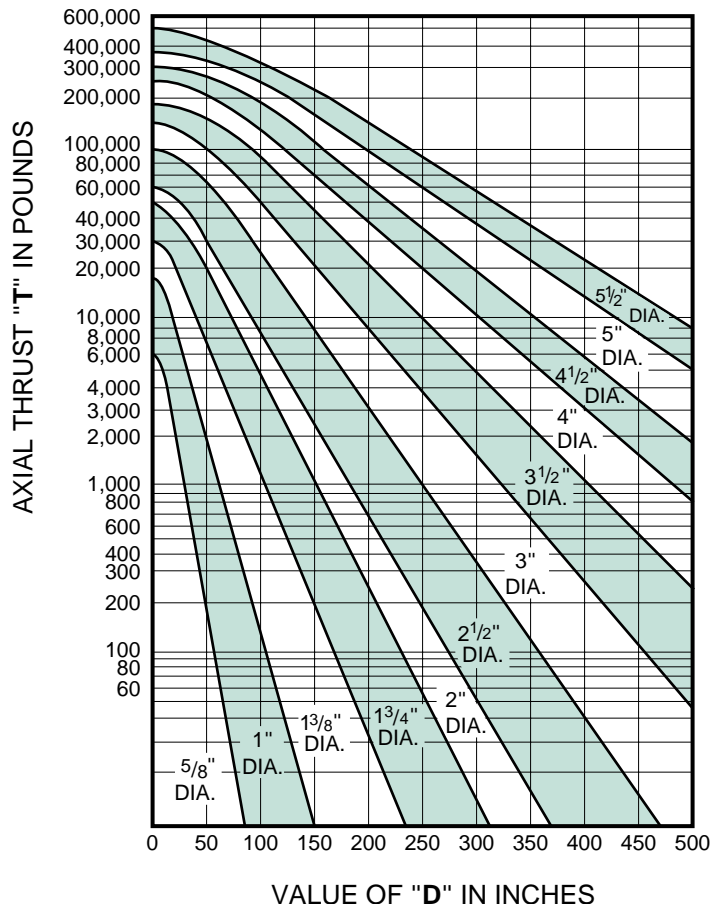

Hydro-Line Technical Data

Pressure-Thrust-Consumption-Flow Charts

Standard Operating Pressure Rating				Out-Stroke Thrust In Pounds Force												Consumption Per Inch Of Stroke in One Direction		
Cyl. Bore in Inches	LA5 A5 LR5 R5	HA5* HR5	Piston Area Sq. In.	Pressures of Operating Medium – Air or Hydraulic												Oil Gallons Displaced	Air Pressure Cubic Ft. Displaced	Free Air Cubic Ft. @ 80 psi Displaced
				50 psi	60 psi	80 psi	100 psi	200 psi	250 psi	500 psi	750 psi	1000 psi	1500 psi	2000 psi	3000 psi			
1	200	3000	.79	40	47	63	79	158	198	395	593	790	1,185	1,580	2,356	.00340	.00050	.00320
1 1/2	200	1500	1.84	92	110	147	184	368	460	920	1,380	1,840	2,760	–	–	.00797	.00106	.00683
2	200	1500	3.24	162	194	259	324	648	810	1,620	2,430	3,240	4,860	–	–	.01403	.00188	.01211
2 1/2	200	1000	5.03	252	302	402	503	1,006	1,258	2,520	3,773	5,030	–	–	–	.02177	.00291	.01875
3 1/2	200	1500	8.45	423	507	676	845	1,690	2,113	4,230	6,338	8,450	12,675	–	–	.03658	.00489	.03149
4	200	1000	12.76	638	766	1,021	1,276	2,552	3,190	6,380	9,570	12,760	–	–	–	.05524	.00738	.04755
5	200	750	19.87	994	1,192	1,590	1,987	3,974	4,968	9,940	14,903	–	–	–	–	.08602	.01150	.07405
6	200	750	28.56	1,428	1,714	2,285	2,856	5,712	7,140	14,280	21,420	–	–	–	–	.12364	.01653	.10644
8	200	500	50.64	2,532	3,038	4,051	5,064	10,128	12,660	25,320	–	–	–	–	–	.21922	.02931	.18873
10	200	500	79.01	3,951	4,741	6,321	7,901	15,802	19,753	39,510	–	–	–	–	–	.34203	.04572	.29446
12	200	400	113.66	5,683	6,820	9,093	11,366	22,732	28,415	56,830*	–	–	–	–	–	.49203	.06578	.42359
14	200	400	154.60	7,730	9,276	12,368	15,460	30,920	38,650	77,300*	–	–	–	–	–	.66926	.08947	.57617
16	200	500	201.82	10,091	12,109	16,146	20,182	40,364	50,455	109,910	–	–	–	–	–	.87368	.11679	.75215
18	200	500	255.32	12,766	15,319	20,426	25,532	51,064	63,830	127,660	–	–	–	–	–	1.10528	.14775	.95154
20	200	500	315.10	15,755	18,906	25,208	31,510	63,020	78,775	157,550	–	–	–	–	–	1.36407	.18235	1.17433

* 400 psi maximum operating pressure for HA5
Below are cylinder sizes for which the rod diameters in the column to the left are standard. Consult bulletins for rods larger than standard.

Thrusts for pressures not shown in table, add the thrust for two or more operating pressures which combined equal the desired pressure.

1 Gallon = 231 Cubic Inches
Oil consumption gal. per min = Gal. per in. times in. per min. piston speed
Air consumption cubic ft. per min = Cu. ft. per in. times in. per min. piston speed
Free air consumption per in. of stroke = Cu. ft. displaced x (press. + 14.7) ÷ 14.7

Piston Rod Dia. in Inches	R5 LR5 HR5	Piston Rod Area Sq. In.	In-Stroke Pull In Pounds Force Deduct The Following Force Or Consumptions Corresponding To Rod Size From Out-Stroke Thrust Or Consumptions To Determine In-Stroke Pull Or Consumptions												Consumption Per Inch Of Stroke in One Direction		
			Pressures of Operating Medium – Air or Hydraulic												Oil Gallons Displaced	Air Pressure Cubic Ft. Displaced	Free Air Cubic Ft. @ 80 psi Displaced
50 psi	60 psi	80 psi	100 psi	200 psi	250 psi	500 psi	750 psi	1000 psi	1500 psi	2000 psi	3000 psi						
1/2	1	.20	10	12	16	20	40	50	100	150	200	300	400	600	.00090	.00010	.00007
3/8	1, 1 1/2, 2 & 2 1/2	.31	16	19	25	31	62	78	155	233	310	465	620	930	.00138	.00018	.00116
1	3 1/4, 4, 5	.79	40	47	63	79	158	198	395	593	790	1,185	–	–	.00342	.00046	.00294
1 1/8	6, 8	1.49	75	89	119	149	298	373	745	1,118	–	–	–	–	.00645	.00086	.00555
1 1/4	10	2.41	121	145	193	241	482	603	1,205	–	–	–	–	–	.01043	.00139	.00898
2	12	3.14	157	188	251	314	628	785	1,570	–	–	–	–	–	.01359	.00182	.01170
2 1/2	14	4.91	246	295	393	491	982	1,228	2,455	–	–	–	–	–	.02126	.00284	.01830
3	–	7.07	354	424	566	707	1,414	1,768	3,535	–	–	–	–	–	.03061	.00409	.02635
3 1/2	16	9.62	481	577	770	962	1,924	2,405	4,810	–	–	–	–	–	.04165	.00557	.03585
4	18, 20	12.57	629	754	1,006	1,257	2,514	3,143	6,285	–	–	–	–	–	.05442	.00727	.04685
4 1/2	–	15.90	795	954	1,272	1,590	3,180	3,975	7,950	–	–	–	–	–	.06883	.00920	.05926
5	–	19.63	982	1,178	1,570	1,963	3,926	4,908	9,815	–	–	–	–	–	.08498	.01136	.07316
5 1/2	–	23.76	1,188	1,426	1,901	2,376	4,752	5,940	11,880	–	–	–	–	–	.10286	.01375	.08855

NOTE: Bore Dimensions Are 0.030" Larger Than NOMINAL except for 1" bore.

Pipe Size Chart for Hydraulic Cylinders and Systems

Standard Weight Pipe			Oil Flow Gallons Per Minute And Friction Pressure Drop Pounds Per Square Inch Per Foot Length Of Pipe											
Pipe Size	Inside Diameter*	Area Sq. In.	Vel. = 5 Ft. Per Sec.		Vel. = 10 Ft. Per Sec.		Vel. = 15 Ft. Per Sec.		Vel. = 20 Ft. Per Sec.		Vel. = 25 Ft. Per Sec.		Vel. = 30 Ft. Per Sec.	
			Gallons per Minute	Pressure Drop in psi	Gallons per Minute	Pressure Drop in psi	Gallons per Minute	Pressure Drop in psi	Gallons per Minute	Pressure Drop in psi	Gallons per Minute	Pressure Drop in psi	Gallons per Minute	Pressure Drop in psi
1/2	.622	.304	4.7	.157	9.4	.585	14.1	1.215	18.6	2.065	23.5	3.130	28.2	4.34
3/4	.824	.533	8.3	.117	16.6	.370	24.9	.710	33.2	1.520	41.5	2.300	49.8	3.17
1	1.049	.864	13.5	.090	26.9	.323	40.4	.673	53.8	1.555	67.3	1.725	80.8	2.44
1 1/4	1.380	1.495	23.3	.064	46.5	.231	69.8	.488	93.0	.755	116.3	1.240	139.6	1.74
1 1/2	1.610	2.036	31.7	.054	63.4	.181	95.1	.404	126.8	.691	158.5	1.042	190.2	1.48
2	2.067	3.355	52.3	.047	104.5	.169	156.8	.360	209.0	.609	261.3	.927	313.6	1.11

Standard Weight Pipe			Equivalent Length of Straight Pipe in Feet for Various Fitting					
Pipe Size	Inside Diameter*	Area Sq. In.	Std. Elbow	Std. Tee	Gate Valve	Globe Valve	Cylinders & 2-3 Way Valves	4-Way Valves
1/2	.622	.304	1.5	3.3	.35	17	6 to 30	12 to 60
3/4	.824	.533	2.2	4.5	.47	22	10 to 50	20 to 100
1	1.049	.864	2.7	5.8	.60	28	13 to 65	25 to 125
1 1/4	1.380	1.495	3.7	7.7	.81	37	15 to 75	30 to 150
1 1/2	1.610	2.036	4.4	9.2	.92	44	20 to 100	40 to 200
2	2.067	3.355	5.5	12.0	1.20	57	25 to 125	50 to 250

The pressure drop shown in the above table is for ordinary wrought iron pipe. For smooth, new wrought iron pipes, multiply the values shown by .7; for very smooth, straight tubing, multiply the values shown by .54. Pressure drop is the same regardless of operating pressure. Avoid large pressure drops in low pressure systems. Note that oil flows through large pipes at high velocity (up to 30 ft. per sec.) with small pressure loss. The pressure drop shown is for hydraulic oil with approximately 225 SSU at 100°F under average operating conditions. The values also apply to water. In order to accommodate large pump volumes without severe pressure drops, all Hydro-Line hydraulic cylinders are available with oversize ports with welded half pipe couplings or flange fitting.

* Inside diameter and areas shown are standard pipe. For tubing or extra heavy and double extra heavy pipe, use I.D. in table closest to your pipe or tubing I.D.

R5 and A5 Cylinder Port Size Data and Port, Cushion Adjustment and Ball Check Location Information

Ports

Standard ports for HR5, HA5 and WBR5 are SAE straight thread. R5, LR5, A5 and LA5 standard ports are NPT.

Optional and Oversize Ports

The chart at right lists port sizes. Larger welded half-pipe coupling ports are available in some sizes, please contact Hydro-Line. For oversize ports where short restrictions in dash pot areas cannot be allowed, specify "full flow porting."

Hydraulic Pressure Ratings (R5 Only)

Cylinder Bore (inches)	Piston Rod Diameters (inches)			Pressure Ratings (psi)	
	Standard	Oversize	2:1	Heavy-Duty Service	4:1 Design Factory (Yield)†
1	1/2	5/8		3000	1800
1 1/2	5/8		1	1500	1600
2	5/8	1	1 3/8	1500	1500
2 1/2	5/8	1, 1 3/8	1 3/4	1000	1000
3 1/4	1	1 3/8, 1 3/4	2	1500	900
4	1	1 3/8, 1 3/4, 2	2 1/2	1000	650
5	1	1 3/8, 1 3/4, 2, 2 1/2, 3	3 1/2	750*	650
6	1 3/8	1 3/4, 2, 2 1/2, 3, 3 1/2	4	750	500
8	1 3/8	1 3/4, 2, 2 1/2, 3, 3 1/2, 4, 4 1/2, 5	5 1/2	500	600
10	1 3/4	2, 2 1/2, 3, 3 1/2, 4, 4 1/2, 5, 5 1/2		500	550
12	2	2 1/2, 3, 3 1/2, 4, 4 1/2, 5, 5 1/2		400	400
14	2 1/2	3, 3 1/2, 4, 4 1/2, 5, 5 1/2		400	400
16	3 1/2	4, 4 1/2, 5, 5 1/2		500	750
18	4	4 1/2, 5, 5 1/2		500	720
20	4	4 1/2, 5, 5 1/2		500	650

* Use 1 3/8" diameter rod or larger in 5-inch bore pull applications with over 700 psi heavy-duty or 1110 psi nonshock operating pressure.

† Based on minimum yield point of weakest component and standard rod size.

NOTE: R5 and LR5 Series for air service only. Pressures up to 200 psi air.
NOTE: Maximum operating pressure 400 psi for A5.

Cylinder Bore Dia. (inches)	Cylinder Rod Dia. (inches)	SAE			NPT			Manifold	
		Std.	Oversize		Std.	Oversize		"A" Mount	"B" Mount
			Head	Cap		Head	Cap		
1"	1/2"	#6	N/A	N/A	1/4"	3/8"	3/8"	1/4"	N/A
	5/8"	#6	N/A	N/A	1/4"	3/8"	3/8"	1/4"	N/A
1 1/2"★★	5/8"	#6	N/A	N/A	3/8"	N/A	N/A	1/2"	3/16"
	1"	#6	N/A	N/A	3/8"	N/A	N/A	1/2"	3/16"
2"	5/8"	#6	#8	N/A	3/8"	1/2"	N/A	1/2"	1/4"
	1"	#6	N/A	N/A	3/8"	N/A	N/A	1/2"	1/4"
	1 3/8"	#6	N/A	N/A	3/8"	N/A	N/A	1/2"	1/4"
2 1/2"	5/8"	#6	#8	N/A	3/8"	N/A	N/A	1/2"	1/2"
	1"	#6	#8	N/A	3/8"	N/A	N/A	1/2"	1/2"
	1 3/8"	#6	N/A	N/A	3/8"	N/A	N/A	1/2"	1/2"
	1 3/4"	#6	N/A	N/A	3/8"	N/A	N/A	1/2"	1/2"
3 1/4"	1"	#10	#12	N/A	1/2"	3/4"	N/A	5/8"	5/8"
	1 3/8"	#10	#12	N/A	1/2"	3/4"	N/A	5/8"	5/8"
	1 3/4"	#10	N/A	N/A	1/2"	3/4"	N/A	5/8"	5/8"
	2"	#10	N/A	N/A	1/2"	N/A	N/A	5/8"	5/8"
4"	1"	#10	#12	N/A	1/2"	N/A	N/A	5/8"	5/8"
	1 3/8"	#10	#12	N/A	1/2"	N/A	N/A	5/8"	5/8"
	1 3/4"	#10	#12	N/A	1/2"	N/A	N/A	5/8"	5/8"
	2"	#10	#12	N/A	1/2"	N/A	N/A	5/8"	5/8"
	2 1/2"	#10	N/A	N/A	1/2"	N/A	N/A	5/8"	5/8"
5"	1"	#10	#12	N/A	1/2"	N/A	N/A	5/8"	5/8"
	1 3/8"	#10	#12	N/A	1/2"	N/A	N/A	5/8"	5/8"
	1 3/4"	#10	#12	N/A	1/2"	N/A	N/A	5/8"	5/8"
	2"	#10	#12	N/A	1/2"	N/A	N/A	5/8"	5/8"
	2 1/2"	#10	#12	N/A	1/2"	N/A	N/A	5/8"	5/8"
	3"	#10	N/A	N/A	1/2"	N/A	N/A	5/8"	5/8"
	3 1/2"	#10	N/A	N/A	1/2"	N/A	N/A	5/8"	5/8"
6"	1 3/8"	#12	#14	N/A	3/4"	N/A	N/A	13/16"	13/16"
	1 3/4"	#12	#14	N/A	3/4"	N/A	N/A	13/16"	13/16"
	2"	#12	#14	N/A	3/4"	N/A	N/A	13/16"	13/16"
	2 1/2"	#12	#14	N/A	3/4"	N/A	N/A	13/16"	13/16"
	3"	#12	#14	N/A	3/4"	N/A	N/A	13/16"	13/16"
	3 1/2"	#12	#14	N/A	3/4"	N/A	N/A	13/16"	13/16"
8"	1 3/8"	#12	#14	N/A	3/4"	1"	N/A	13/16"	13/16"
	1 3/4"	#12	#14	N/A	3/4"	1"	N/A	13/16"	13/16"
	2"	#12	#14	N/A	3/4"	1"	N/A	13/16"	13/16"
	2 1/2"	#12	#14	N/A	3/4"	1"	N/A	13/16"	13/16"
	3"	#12	#14	N/A	3/4"	1"	N/A	13/16"	13/16"
	3 1/2"	#12	#14	N/A	3/4"	1"	N/A	13/16"	13/16"
	4"	#12	#14	N/A	3/4"	1"	N/A	13/16"	13/16"
	4 1/2"	#12	#14	N/A	3/4"	1"	N/A	13/16"	13/16"
	5"	#12	#14	N/A	3/4"	1"	N/A	13/16"	13/16"
	5 1/2"	#12	#14	N/A	3/4"	1"	N/A	13/16"	13/16"
10"	1 3/4"	#16	#20	N/A	1"	N/A	N/A	1 1/16"	1 1/16"
	2"	#16	#20	N/A	1"	N/A	N/A	1 1/16"	1 1/16"
	2 1/2"	#16	#20	N/A	1"	N/A	N/A	1 1/16"	1 1/16"
	3"	#16	#20	N/A	1"	N/A	N/A	1 1/16"	1 1/16"
	3 1/2"	#16	#20	N/A	1"	N/A	N/A	1 1/16"	1 1/16"
	4"	#16	#20	N/A	1"	N/A	N/A	1 1/16"	1 1/16"
	4 1/2"	#16	#20	N/A	1"	N/A	N/A	1 1/16"	1 1/16"
	5"	#16	#20	N/A	1"	N/A	N/A	1 1/16"	1 1/16"
5 1/2"	#16	#20	N/A	1"	N/A	N/A	1 1/16"	1 1/16"	
12"	2"	#16	#20	N/A	1"	N/A	N/A	1 1/16"	1 1/16"
	2 1/2"	#16	#20	N/A	1"	N/A	N/A	1 1/16"	1 1/16"
	3"	#16	#20	N/A	1"	N/A	N/A	1 1/16"	1 1/16"
	3 1/2"	#16	#20	N/A	1"	N/A	N/A	1 1/16"	1 1/16"
	4"	#16	#20	N/A	1"	N/A	N/A	1 1/16"	1 1/16"
	4 1/2"	#16	#20	N/A	1"	N/A	N/A	1 1/16"	1 1/16"
	5"	#16	#20	N/A	1"	N/A	N/A	1 1/16"	1 1/16"
	5 1/2"	#16	#20	N/A	1"	N/A	N/A	1 1/16"	1 1/16"
14"	2 1/2"	#20	#24	N/A	1 1/4"	1 1/2"	N/A	1 3/8"	1 3/8"
	3"	#20	#24	N/A	1 1/4"	1 1/2"	N/A	1 3/8"	1 3/8"
	3 1/2"	#20	#24	N/A	1 1/4"	1 1/2"	N/A	1 3/8"	1 3/8"
	4"	#20	#24	N/A	1 1/4"	1 1/2"	N/A	1 3/8"	1 3/8"
	4 1/2"	#20	#24	N/A	1 1/4"	1 1/2"	N/A	1 3/8"	1 3/8"
	5"	#20	#24	N/A	1 1/4"	1 1/2"	N/A	1 3/8"	1 3/8"
	5 1/2"	#20	#24	N/A	1 1/4"	1 1/2"	N/A	1 3/8"	1 3/8"
16"	3 1/2"	#20	#24	#24	1 1/2"	N/A	N/A	*	*
	4"	#20	#24	#24	1 1/2"	N/A	N/A	*	*
	4 1/2"	#20	#24	#24	1 1/2"	N/A	N/A	*	*
	5"	#20	#24	#24	1 1/2"	N/A	N/A	*	*
	5 1/2"	#20	#24	#24	1 1/2"	N/A	N/A	*	*
18"	4"	#24	#32	#32	1 1/2"	2"	2"	*	*
	4 1/2"	#24	#32	#32	1 1/2"	2"	2"	*	*
	5"	#24	#32	#32	1 1/2"	2"	2"	*	*
	5 1/2"	#24	#32	#32	1 1/2"	2"	2"	*	*
20"	4"	#32	N/A	N/A	2"	2 1/2"	2 1/2"	*	*
	4 1/2"	#32	N/A	N/A	2"	2 1/2"	2 1/2"	*	*
	5"	#32	N/A	N/A	2"	2 1/2"	2 1/2"	*	*
	5 1/2"	#32	N/A	N/A	2"	2 1/2"	2 1/2"	*	*

★ Consult factory.

★★ Port adapter 1" in diameter and 3/4" high furnished on head end only on 1 1/2" bore cylinders with 1" diameter rod.

R5 and A5 Cylinder Port Size Data and Port, Cushion Adjustment and Ball Check Location Information

Port, Cushion Adjustment, Ball Check Locations

Standard port locations are at No. 1, with optional locations Nos. 2, 3, 4 or 5 furnished when specified, except where **H**, **U** or **W** mounts interfere at No. 2 and 4. Ports at No. 3 in **B** and the cap end of **E** mountings need special construction. Note possible piping interference with mounting screws in **A** cylinders ported at Pos. 2 and 4. Mounting holes are counterbored to allow access to them with piping in place. Request Engineering File P-26 for reference to dimensions.

In the end view shown, standard position of cushion adjustment is above port location No. 2 in location C3; ball check above port location No. 4 at C8. On **H**, the head on **G**, **U** and the cap on **P**, **W** cushion adjustments are on the right side of port location No. 3 at C5, and checks are on the left side at C6. For distance dimensions of ball checks and needles from the port locations, request Engineering File P-123C.

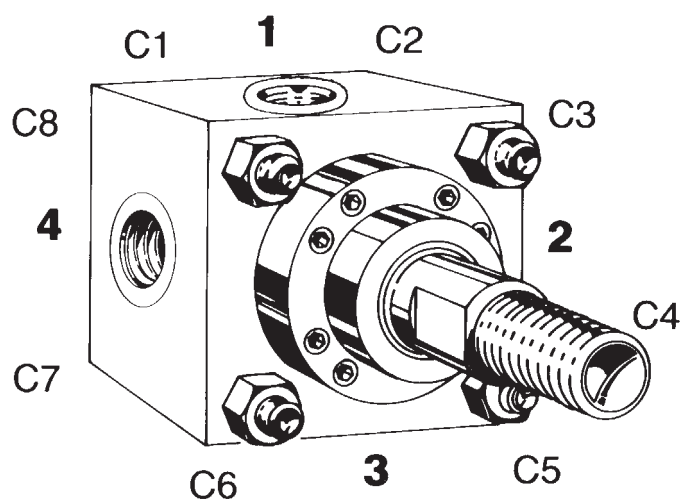

Locations 1 through 4 indicate possible port positions.

Number 1 is standard. Optional location No. 5 is available on cap end centerline.

Locations C1 through C8 indicate possible cushion adjustment positions. C3 is standard. C8 is standard ballcheck location.

Standard Cushion Information

CYLINDER BORE DIAMETER (inches)	PISTON ROD DIAMETER* (inches)	CUSHION LENGTH		PLUNGER CROSS-SECTIONAL AREA	
		HEAD	CAP	HEAD	CAP
1	1/2	.64	.81	.291	.074
1 1/2	5/8	.87	.81	.602	.138
2	5/8	.87	.81	.602	.138
2 1/2	5/8	.87	.81	.602	.138
3 1/4 4 & 5	1	1.12	1.0	1.108	.331
6	1 3/8	1.37	1.25	2.076	.601
8	1 3/8	1.37	1.25	2.076	.601
10	1 3/4	1.37	1.75	3.144	.601
12	2	1.37	1.75	4.433	1.226
14	2 1/2	1.37	2	6.496	2.40

* In checking oversized rod cylinders, use the same dimensions as for standard rods excepting the head end plunger cross-sectional area. For this, find the rod desired in the second column and use head end plunger cross-sectional area.

Refer to Technical Data form TD-213 to calculate your hydraulic cushion requirements.

Because of space limitations, a fixed cushion only is available on the head end in the 1" bore with 5/8" diameter rod, 1 1/2" bore with 1" diameter rod, 2" bore with 1 3/8" diameter rod, and 2 1/2" bore with a 1 3/4" diameter rod.

Mounting Accessories

Pivot Pin

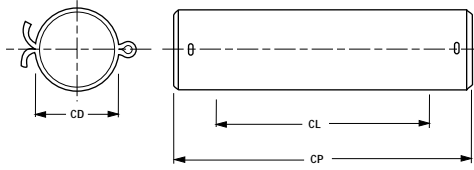

Part No.	CD	CL	CP
C-9001-3	5/16	13/16	1
C-9002-3	7/16	15/16	1 3/4
C-9003-3	1/2	1 3/4	2 3/8
C-9004-3	3/4	2 1/2	3 1/8
C-90065-3	1	3	3 3/4
C-9008-3	1 3/8	4	4 3/4
C-9010-3	1 3/4	5	6 1/32
C-9012-3	2	5	6 1/32
C-9014-3	2 1/2	6	7 1/32
C-9016-3	3	6	7 1/8
C-9020-3	3 1/2	8	9 5/8
C-9024-3	4	9	10 5/8

- Pivot pins are furnished with clevis mounted cylinders.
- Pivot pins must be ordered as a separate item if to be used with female eye, female clevis, standard eye bracket and clevis bracket. They are included only with swivel eye bracket.
- CL=2(CW) + CB

Female Eye

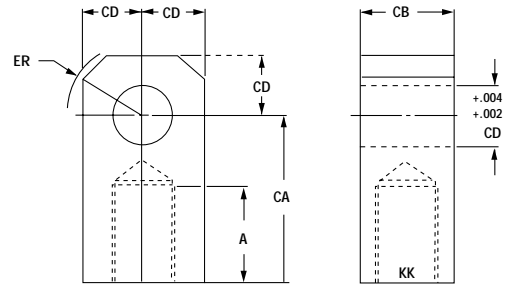

Part No.	A	CA	CB	CD	ER	KK
C-9302	3/4	1 1/2	7/16	7/16	19/32	5/16-24
C-9303	3/4	1 1/2	3/4	1/2	5/8	7/16-20
C-9304	1 1/8	2 1/16	1 1/4	3/4	7/8	3/4-16
C-93065	1 5/8	2 13/16	1 1/2	1	1 3/16	1-14
C-9308	2	3 7/16	2	1 3/8	1 9/16	1 1/4-12
C-9310	2 1/4	4	2 1/2	1 3/4	2	1 1/2-12
C-9312	3	5	2 1/2	2	2 1/4	1 7/8-12
C-9314	3 1/2	5 13/16	3	2 1/2	2 13/16	2 1/4-12
C-9316	3 1/2	6 1/8	3	3	3 1/4	2 1/2-12
C-9320	4 1/2	7 5/8	4	3 1/2	3 7/8	3 1/4-12
C-9324	5 1/2	9 1/8	4 1/2	4	4 7/16	4-12

Female Clevis

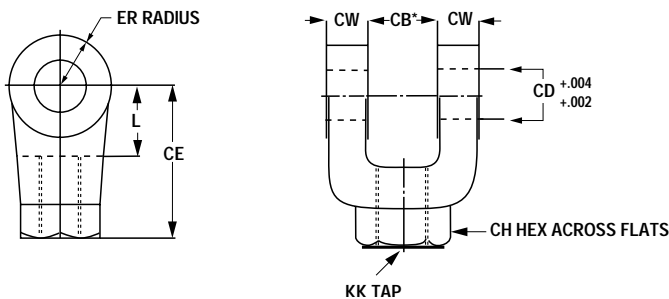

- * Maximum width of mating part
NOTE: CN-133 Clevis Bracket is not adaptable to the cylinder as an MP2 bracket.

Part No.	CB	CD	CE	CH	CW	ER	KK	L
C-134-04	1 1/32	5/16	2 1/4	N/A	7/32	5/16	5/16-24	1 7/16
C-134-05	3/4	1/2	1 1/2	7/8	1/2	1/2	7/16-20	3/4
C-134-08	1 1/4	3/4	2 3/8	1 3/8	5/8	3/4	3/4-16	1 1/4
C-134-11	1 1/2	1	3 1/8	1 5/8	3/4	1	1-14	1 1/2
C-134-14	2	1 3/8	4 1/8	2	1	1 3/8	1 1/4-12	2 1/8
C-134-16	2 1/2	1 3/4	4 1/2	2 3/8	1 1/4	1 3/4	1 1/2-12	2 1/4
C-134-20	2 1/2	2	5 1/2	2 15/16	1 1/4	2	1 7/8-12	2 1/2
C-134-24	3	2 1/2	6 1/2	3 1/2	1 1/2	2 1/2	2 1/4-12	3
C-134-28	3	3	6 3/4	3 7/8	1 1/2	2 3/4	2 1/2-12	3 1/4
C-134-36	4	3 1/2	8 1/2	5	2	3 1/2	3 1/4-12	4
C-134-44	4 1/2	4	10	6 1/8	2 1/4	4	4-12	4 1/2

Clevis Bracket

CR-133-02 only

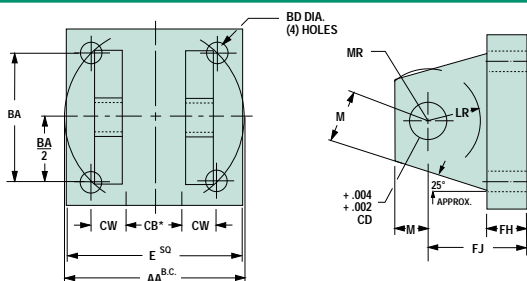
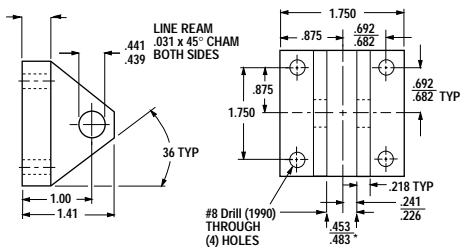

Part No.	AA	BA	CB	CD	CW	DD	E	FH	FJ	LR	M	MR
CN-133-03	2.3	1 5/8	25/32	1/2	1/2	3/8-24	2 1/2	3/8	1 1/8	1/2	1/2	9/16
CN-133-04	2.9	2 1/16	19/32	3/4	5/8	1/2-20	3	5/8	1 7/8	1	3/4	1 1/16
CN-133-05	3.6	2 9/16	19/32	3/4	5/8	1/2-20	3 1/2	5/8	1 7/8	1 1/16	3/4	1 1/16
CN-133-065	4.6	3 1/4	1 17/32	1	3/4	5/8-18	4 1/2	3/4	2 1/4	1 1/4	1	1 1/8
CN-133-08	5.4	3 13/16	2 1/32	1 3/8	1	5/8-18	5	7/8	3	1 7/8	1 3/8	1 3/4
CN-133-10	7.0	4 15/16	2 17/32	1 3/4	1 1/4	7/8-14	6 1/2	7/8	3 1/8	2	1 3/4	1 7/8
CN-133-12	8.1	5 3/4	2 17/32	2	1 1/4	1-14	7 1/2	1	3 1/2	2 1/8	2	2 1/8
CN-133-14	9.3	6 19/32	3 1/32	2 1/2	1 1/2	1 1/8-12	8 1/2	1	4	2 5/8	2 1/2	2 1/2
CN-133-16	10.6	7 1/2	3 1/32	3	1 1/2	1 1/4-12	9 1/2	1	4 1/4	2 7/8	2 3/4	2 3/4
CN-133-20	13.6	9 5/8	4 1/16	3 1/2	2	1 3/4-12	12 5/8	1 11/16	5 11/16	3 5/8	3 1/2	3 1/2
CN-133-24	16.2	11 1/2	4 9/16	4	2 1/4	2-12	14 7/8	1 15/16	6 7/16	4	4	4

* Maximum width of mating part

Mounting Accessories

Swivel Eye Bracket* Standard Eye Bracket

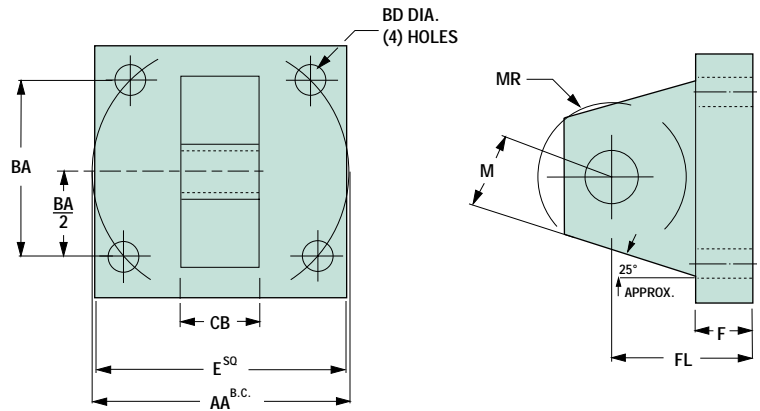

(Includes spacers to allow swivel action up to 7° and to make dimensions interchangeable with standard eye bracket.)

Part Number		Dimensions										Standard Bracket		Swivel Bracket		Swivel Bracket Recommended Static Load Limit in Pounds
Std.	Swivel*	AA	BA	BD	CB	CD	E	F**	FL**	LR	M	MR	M	MR		
C-8903	C-219-3-1	2.3	1 ⁵ / ₈	1 ³ / ₃₂	3/4	1/2	2 ¹ / ₂	3/8	1 ¹ / ₈	1/2	1/2	9/16	1 ¹ / ₁₆	1 ¹ / ₁₆	8,100	
C-8904	C-219-3-2	3.6	2 ⁹ / ₁₆	1 ⁷ / ₃₂	1 ¹ / ₄	3/4	3 ¹ / ₂	5/8	1 ⁷ / ₈	1	3/4	1 ¹ / ₁₆	1 ³ / ₁₆	1 ³ / ₁₆	18,800	
C-89065X	C-219-3-3X	4.6	3 ¹ / ₄	2 ¹ / ₃₂	1 ¹ / ₂	1	4 ¹ / ₂	7/8	2 ³ / ₈	1	1	1 ¹ / ₈	1 ³ / ₈	1 ³ / ₈	33,300	
C-8908	C-219-3-4	5.4	3 ¹³ / ₁₆	2 ¹ / ₃₂	2	1 ³ / ₈	5	7/8	3	1 ¹ / ₈	1 ³ / ₈	1 ³ / ₄	2	2	59,800	
C-8910X	C-219-3-5X	7.0	4 ¹⁵ / ₁₆	2 ⁹ / ₃₂	2 ¹ / ₂	1 ³ / ₄	6 ¹ / ₂	1 ¹ / ₈	3 ³ / ₈	1 ³ / ₄	1 ³ / ₄	1 ⁷ / ₈	2 ¹ / ₈	2 ¹ / ₈	102,000	
C-8912X	C-219-3-6X	8.1	5 ³ / ₄	1 ¹ / ₃₂	2 ¹ / ₂	2	7 ¹ / ₂	1 ¹ / ₂	4	2	2	2 ¹ / ₈	2 ³ / ₈	2 ³ / ₈	132,000	
C-8914X		9.3	6 ¹⁹ / ₃₂	1 ⁵ / ₃₂	3	2 ¹ / ₂	8 ¹ / ₂	1 ³ / ₄	4 ³ / ₄	2 ¹ / ₂	2 ¹ / ₂	2 ¹ / ₂				
C-8916X		10.6	7 ¹ / ₂	1 ⁹ / ₃₂	3	3	9 ¹ / ₂	2	5 ¹ / ₄	2 ³ / ₄	2 ³ / ₄	2 ³ / ₄				
C-8920		13.6	9 ⁵ / ₈	1 ²⁵ / ₃₂	4	3 ¹ / ₂	12 ⁵ / ₈	1 ¹¹ / ₁₆	5 ¹¹ / ₁₆	3 ¹ / ₂	3 ¹ / ₂	3 ¹ / ₂				
C-8924		16.2	11 ¹ / ₂	2 ¹ / ₃₂	4 ¹ / ₂	4	14 ⁷ / ₈	1 ¹⁵ / ₁₆	6 ⁷ / ₁₆	3 ⁷ / ₈	4	4				

* NOTE: To assure precision fit-up, pivot pins machined to special tolerances are furnished with all swivel eye brackets, unless otherwise specified.
 ** Dimensions F and FL reflect revised NFPA standards. Part numbers with suffix letter X are affected.

Typical Mounting Accessories

For Standard Rod Diameters Style #2

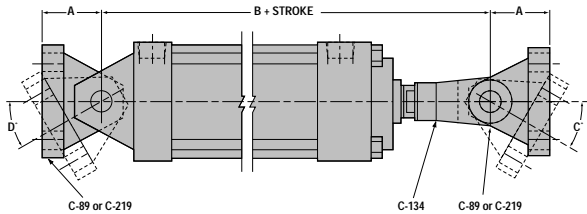

R5 and A5 Cylinders

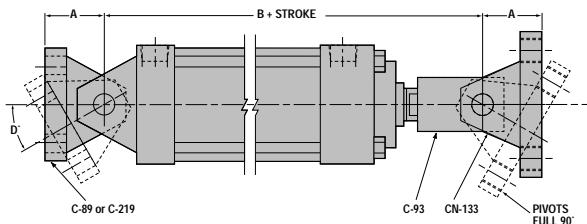

R5 and A5 Cylinders

Bore	A	B	Eye Bracket		Female Clevis	Pivot Pin	C°	D°
			Standard	Swivel				
1	1	7 ¹ / ₄	C-8902	N/A	C-134-04	C-9002-3	90°	60°
1 ¹ / ₂	1 ¹ / ₈	6 ⁷ / ₈	C-8903	C-219-3-1	C-134-05	C-9003-3	90°	60°
2	1 ¹ / ₈	6 ⁷ / ₈	C-8903	C-219-3-1	C-134-05	C-9003-3	90°	60°
2 ¹ / ₂	1 ¹ / ₈	7	C-8903	C-219-3-1	C-134-05	C-9003-3	90°	60°
3 ¹ / ₄	1 ⁷ / ₈	9 ¹ / ₄	C-8904	C-219-3-2	C-134-08	C-9004-3	90°	65°
4	1 ⁷ / ₈	9 ¹ / ₄	C-8904	C-219-3-2	C-134-08	C-9004-3	90°	65°
5	1 ⁷ / ₈	9 ¹ / ₂	C-8904	C-219-3-2	C-134-08	C-9004-3	90°	65°
6	2 ³ / ₈	11 ¹ / ₄	C-89065X	C-219-3-3X	C-134-11	C-9065-3	80°	65°
8	2 ³ / ₈	11 ³ / ₈	C-89065X	C-219-3-3X	C-134-11	C-9065-3	80°	65°
10	3	14 ¹ / ₂	C-8908	C-219-3-4	C-134-14	C-9008-3	90°	70°
12	3 ³ / ₈	15 ⁵ / ₈	C-8910X	C-219-3-5X	C-134-16	C-9010-3	75°	65°
14	4	18 ³ / ₈	C-8912X	C-219-3-6X	C-134-20	C-9012-3	75°	65°

For mounting dimensions over 14" bore, consult Hydro-Line.

Bore	C	B	Eye Bracket		Clevis Bracket	Pivot Pin	Female Eye	D°
			Standard	Swivel				
1	1	6 ¹ / ₂	C-8902	N/A	N/A	C-9002-3	C-9302	60°
1 ¹ / ₂	1 ¹ / ₈	6 ⁷ / ₈	C-8903	C-219-3-1	CN-133-03	C-9003-3	C-9303	60°
2	1 ¹ / ₈	6 ⁷ / ₈	C-8903	C-219-3-1	CN-133-03	C-9003-3	C-9303	60°
2 ¹ / ₂	1 ¹ / ₈	7	C-8903	C-219-3-1	CN-133-03	C-9003-3	C-9303	60°
3 ¹ / ₄	1 ⁷ / ₈	8 ¹⁵ / ₁₆	C-8904	C-219-3-2	CN-133-04	C-9004-3	C-9304	65°
4	1 ⁷ / ₈	8 ¹⁵ / ₁₆	C-8904	C-219-3-2	CN-133-04	C-9004-3	C-9304	65°
5	1 ⁷ / ₈	9 ³ / ₁₆	C-8904	C-219-3-2	CN-133-04	C-9004-3	C-9304	65°
6	2 ³ / ₈	10 ¹⁵ / ₁₆	C-89065X	C-219-3-3X	CN-133-065	C-9065-3	C-93065	65°
8	2 ¹ / ₄	11 ¹ / ₁₆	C-89065	C-219-3-3	CN-133-065	C-9065-3	C-93065	65°
10	3	13 ¹³ / ₁₆	C-8908	C-219-3-4	CN-133-08	C-9008-3	C-9308	70°
12	3 ³ / ₈	15 ¹ / ₈	C-8910X	C-219-3-5X	CN-133-10	C-9010-3	C-9310	65°
14	4	17 ⁷ / ₈	C-8912X	C-219-3-6X	CN-133-12	C-9012-3	C-9312	65°

For mounting dimensions over 14" bore, consult Hydro-Line.

Rod End Coupling

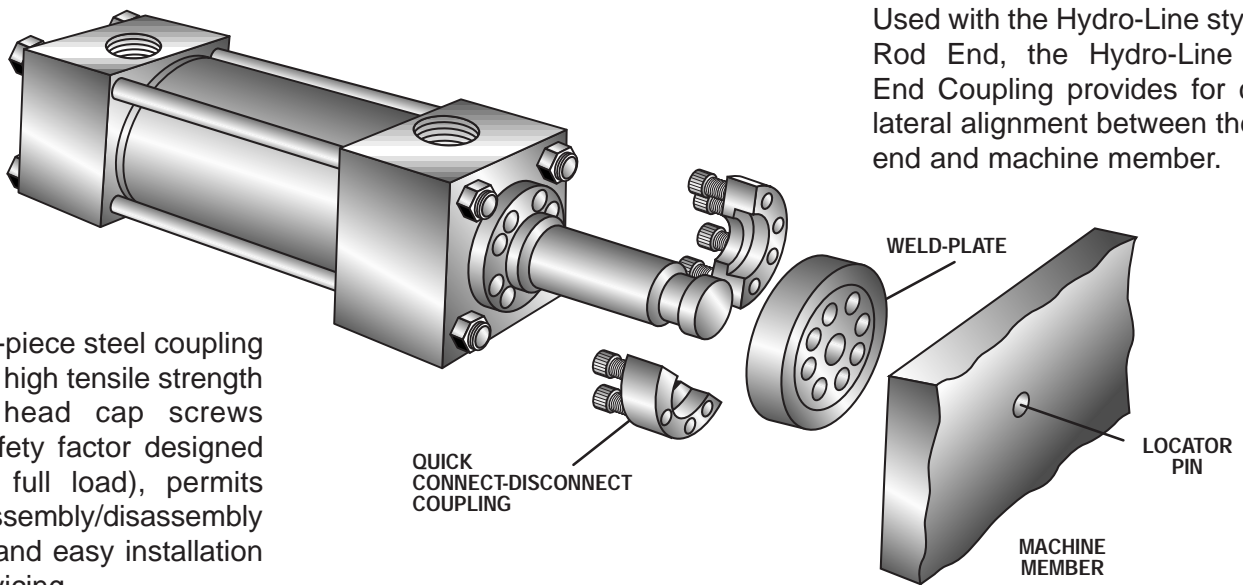

Used with the Hydro-Line style 10 Rod End, the Hydro-Line Rod End Coupling provides for close lateral alignment between the rod end and machine member.

The two-piece steel coupling features high tensile strength socket head cap screws (with safety factor designed to take full load), permits quick assembly/disassembly for fast and easy installation and servicing.

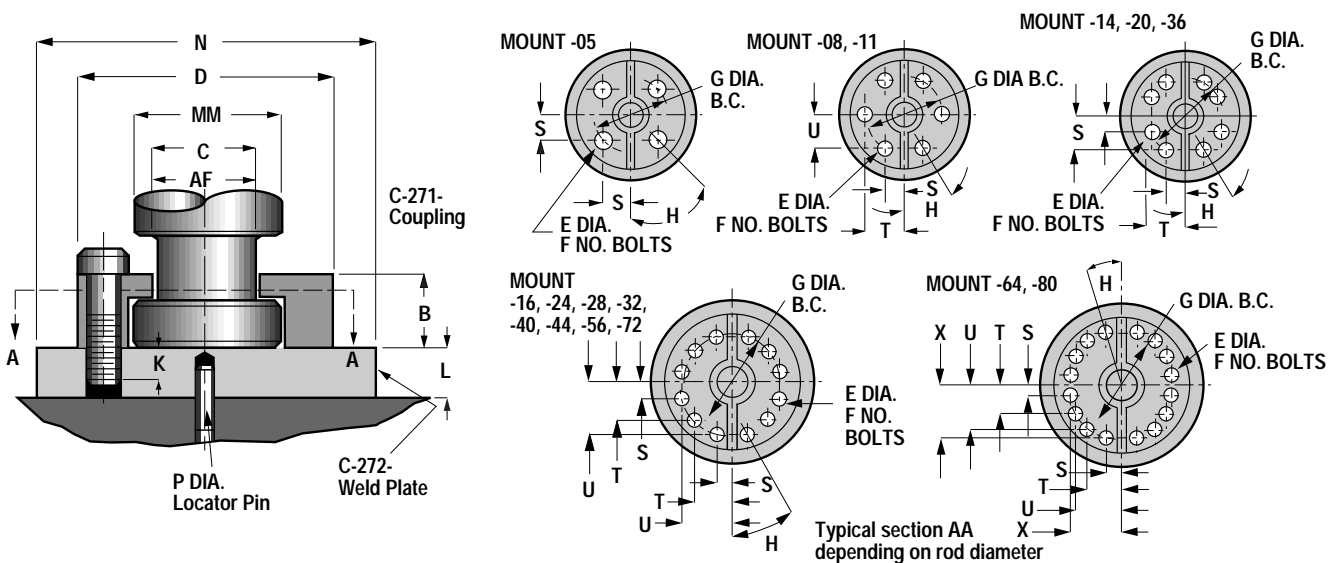

Coupling C-271-	Rod Dia. MM	AF	B	C	D	E	F	G	H	K	Weld Plate C-272-	L	N	P	SOC. HD. CAP. Screws	Bolt Torq. Ft. Lb.	S	T	U	X
C-271-05	.625	.38	.44	.41	1.50	.218	4	1.12	45°	.44	C-272-05	.50	2.00	.25	#10-24 x .88	5	.398	-	-	-
C-271-08	1.000	.69	.62	.75	2.00	.281	6	1.50	30°	.38	C-272-08	.50	2.50	.25	1/4"-20 x 1.0	14	.375	.750	.650	-
C-271-11	1.375	.88	.69	.94	2.50	.343	6	2.00	30°	.56	C-272-11	.62	3.00	.25	5/16"-18 x 1.25	30	.500	1.000	.866	-
C-271-14	1.750	1.12	.88	1.18	3.00	.406	8	2.38	22° 30'	.62	C-272-14	.75	3.50	.25	3/8"-16 x 1.5	52	.454	1.097	-	-
C-271-16	2.000	1.38	1.25	1.44	3.50	.406	12	2.69	15°	.75	C-272-16	.88	4.00	.38	3/8"-16 x 2.0	52	.348	.950	1.298	-
C-271-20	2.500	1.75	1.38	1.88	4.25	.531	8	3.44	30° 30'	.88	C-272-20	1.00	5.00	.38	1/2"-13 x 2.25	128	.658	1.588	-	-
C-271-24	3.000	2.25	1.88	2.38	5.00	.531	12	4.00	15°	.88	C-272-24	1.00	5.50	.38	1/2"-13 x 2.75	128	.518	1.414	1.932	-
C-271-28	3.500	2.50	2.00	2.62	5.88	.656	12	4.69	15°	1.00	C-272-28	1.12	6.50	.38	5/8"-11 x 3.0	255	.607	1.657	2.264	-
C-271-32	4.000	3.00	2.00	3.12	6.38	.656	12	5.18	15°	1.00	C-272-32	1.12	7.00	.38	5/8"-11 x 3.0	255	.671	1.834	2.505	-
C-271-36	4.500	3.50	2.38	3.62	6.88	.781	8	5.69	22° 30'	1.12	C-272-36	1.25	7.50	.38	3/4"-10 x 3.5	450	1.088	2.627	-	-
C-271-40	5.000	3.88	2.50	4.00	7.38	.656	12	6.18	15°	1.25	C-272-40	1.38	8.00	.38	5/8"-11 x 3.75	255	.801	2.188	2.988	-
C-271-44	5.500	4.38	3.12	4.50	8.25	.781	12	6.88	15°	1.38	C-272-44	1.50	9.00	.38	3/4"-10 x 4.5	450	.890	2.431	3.320	-
C-271-56	7.000	5.75	4.00	5.94	10.38	1.031	12	8.75	15°	1.50	C-272-56	1.75	11.00	.50	1"-8 x 5.5	1090	1.132	3.094	4.226	-
C-271-64	8.000	6.50	4.00	6.69	11.38	1.031	16	9.75	11° 15'	1.50	C-272-64	2.00	12.00	.50	1"-8 x 5.5	1090	.951	2.708	4.053	4.781
C-271-72	9.000	7.25	4.00	7.50	13.12	1.281	12	11.12	15°	2.00	C-272-72	2.25	14.00	.50	1 1/4"-7 x 6	2180	1.440	3.933	5.373	-
C-271-80	10.000	8.00	4.50	8.25	14.12	1.281	16	12.12	11° 15'	2.00	C-272-80	2.50	15.00	.50	1 1/4"-7 x 6.5	2180	1.183	3.368	5.040	5.946

To order C-271-__ and C-272-__ as an assembly, use part no. C-275-__

Self-Aligning Coupler

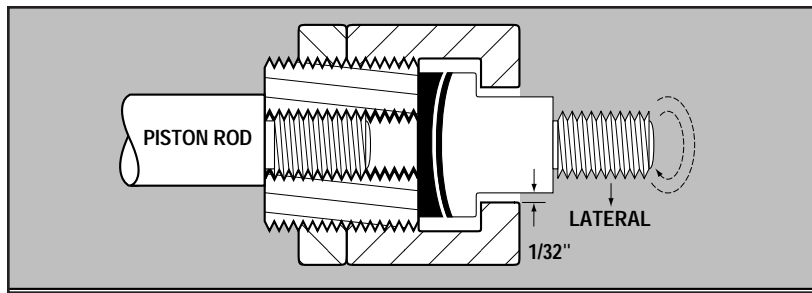

Lateral movement (on push only) and radial movement provide precision alignment between cylinder and machine. Couplers preset with proper clearances and completely lubricated at factory before shipping.

Self-Aligning Rod End Coupler

Rod Part No.	Dia.	A	B	C	D	F	G	H	J	K	KK	Max. Pull At Yield
AC-2-05	5/8	3/4	1 1/4	2	1/2	5/8	1/2	13/16	1-14	5/16	7/16-20	8,320
AC-2-08	1	1 1/8	1 1/16	2 5/16	1/2	31/32	13/16	1 1/8	1 3/8-12	1/2	3/4-16	35,000
AC-2-11	1 3/8	1 5/8	2 3/8	2 29/32	1/2	1 11/32	1 5/32	1 5/8	1 7/8-12	11/16	1-14	64,500
AC-2-14	1 3/4	2	2 5/8	3 19/32	3/4	1 23/32	1 7/16	2	2 1/4-12	21/32	1 1/4-12	82,550
AC-2-16	2	2 1/4	3	4 5/32	7/8	1 31/32	1 3/4	2 3/8	2 5/8-12	29/32	1 1/2-12	128,340
AC-2-20	2 1/2	3	3 3/4	5 7/16	1	2 15/32	2 1/8	3	3 1/4-12	1 5/16	1 7/8-12	231,000
AC-2-24	3	3 1/2	4 1/4	6 3/16	1	2 31/32	▲	3 3/8	3 3/4-12	1 3/16	2 1/4-12	289,200
AC-2-28	3 1/2	3 1/2	5	6 7/16	1	3 15/32	▲	4	4 1/2-12	1 1/2	2 1/2-12	342,400
AC-2-36	4 1/2	4 1/2	6	7 7/8	1	4 15/32	▲	4 3/4	5 1/4-12	1 5/8	3 1/4-12	475,500
AC-2-44	5 1/2	5 1/2	7 1/4	9 3/8	1	5 15/32	▲	5 3/4	6 1/2-12	1 7/8	4-12	750,010

▲ Four 1/2" diameter x 1/2" deep spanner holes instead of flats.

NOTE: When ordering oversize and 2:1 rod cylinders, specify modification to suit standard rod diameter's coupler.

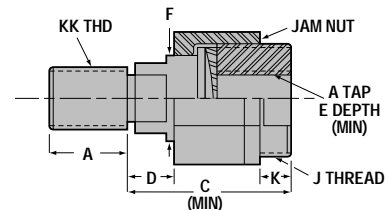
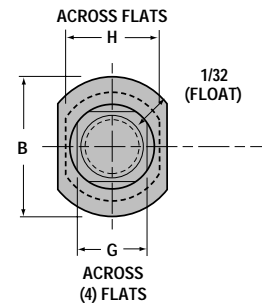

ONE YEAR LIMITED WARRANTY

One Year Normal Use

Hydro-Line Products are warranted for a period of one year from date of shipment from our plant to be free from defects in workmanship and material under correct use, normal operating conditions and proper applications. This warranty does not extend to goods damaged, or subjected to accident, abuse, or misuse after shipment from our factory, nor to goods altered or repaired by anyone other than authorized Hydro-Line representatives.

Disclaimers

This one year limited warranty is the only warranty extended by Hydro-Line in connection with any sale by Hydro-Line. THIS WARRANTY IS IN LIEU OF ALL OTHER WARRANTIES, EXPRESS OR IMPLIED, INCLUDING WARRANTIES OF MERCHANTABILITY AND FITNESS FOR A PARTICULAR PURPOSE, notwithstanding disclosure to Hydro-Line of the product's intended use. An affirmation of fact or promise made on behalf of Hydro-Line shall not be deemed to create an express warranty that the goods shall conform to the affirmation of promise; any description of the goods is for the sole purpose of identifying them and shall not be deemed to create an express warranty that the goods shall conform to such description; any sample or model is for illustrative purposes only and shall not be deemed to create an express warranty that the goods shall conform to the sample or model; and no affirmation or promise, or description, or sample or model, shall be deemed part of the basis of the bargain.

Exclusive Remedy

Hydro-Line's obligation upon breach of warranty shall be limited to replacing or repairing at our option, free of charge, but not including installation, dismantling, reassembling or any other

charge, the particular product or part which inspection discloses to have been defective at time of shipment. Inspection may be at the place of installation and use, or at our plant if returned to us at our expense including lowest transportation cost, is requested. Written notice of such defect shall be given by customer to Hydro-Line within 30 days after such defect(s) appear. Written permission for any warranty claim return must be first obtained from authorized Hydro-Line representatives. All returns must be accompanied with a complete written explanation of claimed defects and the circumstances of operational failure. Replacement of cylinders or parts thereof repaired under this warranty shall be warranted under the terms of this warranty for the remainder of the term of the original warranty or for a period of six months after such repair or replacement, whichever is longer. Upon expiration of the warranty, all of Hydro-Line's obligations hereunder shall terminate.

IN NO EVENT SHALL HYDRO-LINE HAVE ANY LIABILITY FOR PAYMENT OF ANY CONSEQUENTIAL, INCIDENTAL, INDIRECT, SPECIAL OR TORT DAMAGES OF ANY KIND INCLUDING, BUT NOT LIMITED TO, ANY LOSS OF PROFITS, TO THE EXTENT EXCLUSION IS PERMITTED BY LAW.

This warranty states our entire and exclusive liability and buyer's exclusive remedy for any claim of damages in connection with the sale or furnishing of Hydro-Line's products or parts, their design, suitability for use, installations or operation, or for any claimed defects therein. Goods not manufactured by Hydro-Line are furnished subject only to the Manufacturer's warranties, if any, and without warranties, express or implied, by Hydro-Line.

Low Profile Reed and Hall Effect Switches

For use with A5 Series Cylinders only

Hydro-Line Low Profile Reed and Hall effect switches are available for all bore size Q5, A5 and E-Line Series cylinders. These switches are activated by a magnetic band fitted around the cylinder position. Signals from these switches are used as input to programmable controllers, sequencers, relays, and in some cases, to drive valve solenoids.

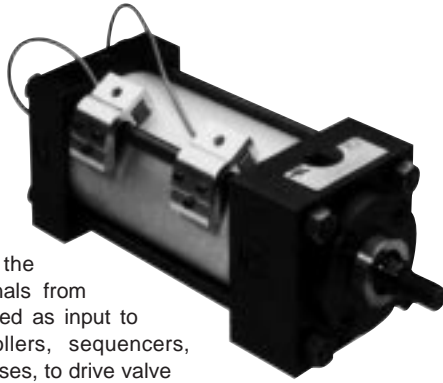

Benefits

- Low profile design is considerably smaller than conventional switches, saving space and providing additional mounting flexibility. (See mounting dimensions.)
- Low profile bracket attaches securely to one tie rod and is easily adjusted over the entire piston travel.
- Several switches may be mounted to control or initiate any sequence or function.
- LED indicator provides convenient means for positioning and troubleshooting circuits.
- Optional quick-connect versions allow electrical disconnection without changing the adjustment of the switch on the cylinder.

Low Profile Switch Selection

Use the requirements in the chart below to determine which switch fits the application. By using the process of elimination, you should be able to choose the proper switch. See the specifications for each switch to confirm your choice.

Requirements	Part No.			
	C-463 & C-463-1	C-464 & C-464-1	C-462 & C-462-1	C-461 & C-461-1
AC				X
DC	X	X	X	
Mechanical Switch			X	X
Solid State Switch (zero bounce)	X	X		
Input for Programmable Controller	X	X	X	X
Coil Direct		X		
Longest Life	X	X		

NOTE: Transient protection should be used with most any switch wired direct to coil.

Low Profile Hall Effect Switches

Hydro-Line Low Profile Hall Effect Switches are solid-state devices designed specifically to provide an input signal to various types of programmable controllers or logic systems. Since Hall Effect Switches are solid-state, there are no moving parts to wear out. Due to this, the switches offer an infinite number of trouble-free operations. Hall Effect Switches operate on DC current only.

	Part No.	
	C-463 & C-463-1	C-464 & C-464-1
Operating Principle	Hall Effect	
Actuated By	Piston Magnet	
Input Voltage	4.5 to 24 VDC	
Output Type	Sinking (NPN)	Sourcing (PNP)
Current Rating	200 mA. Max.	100 mA. Max.
Voltage Drop	.5 VDC Max.	
Switch Burden	10 mA. Max.	
Environmental	NEMA 1, 2, 3, 4, 12, 13, IEC IP67	
Operating Temperature	32° to 176°F	
Switch Color	Yellow	Red

Hall Effect Working Principle

Hydro-Line Low Profile Hall Effect Switches contain a Hall generator (or semi-conductor) which has a current flowing through it (Fig. 30-1). Voltage at the edges of the Hall generator equals 0. When influenced by a magnet, negatively charged electrons "pile up" on one edge of the Hall generator and positive charges on the other, creating a Hall Voltage ($V \neq 0$, Fig. 30-2). This voltage provides the input to the controlling system.

Fig. 30-1

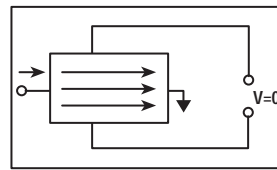
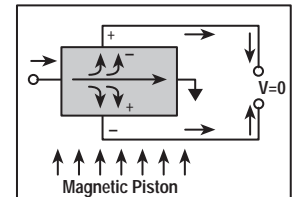
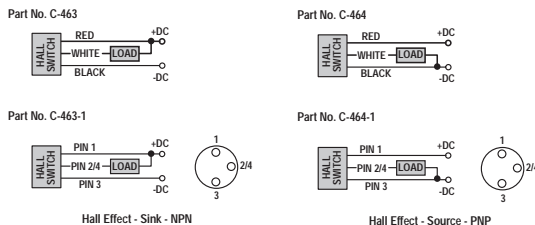

Fig. 30-2



Low Profile Hall Effect Switch Wiring Schematics



NOTE: LED has been omitted from the schematics for clarity.

Sink vs. Source

Hall Effect Switches are available in either a Sink or Source model. The Sink Output connects the load (controller or logic system) to ground (Fig. 30-3). The Source Output connects the load (controller or logic system) to positive (Fig. 30-4). These two outputs are supplied because different logic systems require either current sinking or current sourcing inputs.

Fig. 30-3

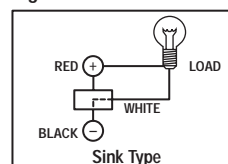
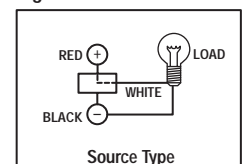

Fig. 30-4



Low Profile Reed Switches

Hydro-Line Low Profile Reed Switches are available in either an AC or DC model. They are ideal for use as inputs for many types of sequencers and programmable controllers. In some cases they can be used to drive some relays or valve solenoids. However, electrical transients (inrush currents or line spikes) associated with inductive or capacitive loads can damage and shorten the life of the switch.

	Part No.	
	C-461 & C-461-1	C-462 & C-462-1
Operating Principle	Magnetic Reed	
Actuated By	Piston Magnet	
Input Voltage	65 to 120 VAC	4.5 to 24 VDC
Current Rating	200 mA. Switched	
Contact Resistance	90 mOhm Max.	
Output Type	Contact Closure	
Environmental	NEMA 1, 2, 3, 4, 12, 13, IEC IP67	
Operating Temperature	32° to 176°F	
Switch Color	Blue	White

Reed Working Principle

Hydro-Line Low Profile Reed Switches contain hermetically sealed reeds (mechanical contacts) which are open in their normal state (Fig. 31-5). When the piston with an axial magnetic band moves within proximity of the switch, magnetism is induced into the reeds. Since magnetic poles attract each other, the ends of the reeds are drawn together making electrical contact (Fig. 31-6). As the piston (with the magnet) moves away, the reeds assume their original open position.

Fig. 31-5

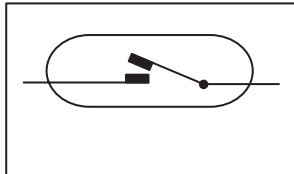
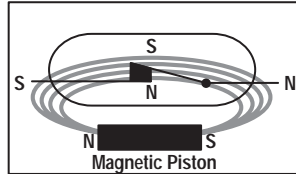
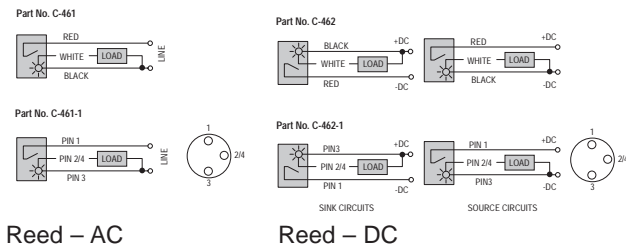

Fig. 31-6



Low Profile Reed Switch Wiring Schematics



Reed – AC

Reed – DC

NOTE: Bi-polar LED emits a green light in the sinking circuit and a red light in the sourcing circuit.

Switch Mounting Brackets

Two different size brackets are required to cover eight bore sizes.

The extruded aluminum brackets mount securely to a single tie rod and do not allow the switch to pull away from the cylinder barrel.

Optional strain relief clamps may be used to protect the switch cable from damage at the switch due to flexing.

Switch Part No.	Cylinder Bore	Switch Bracket Part No.	Strain Relief Clamp Part No.
C-461, C-461-1	1 1/2, 2, 2 1/2,	C-465-1	C-466
C-462, C-462-1	3 1/4 & 4		
C-463, C-463-1	5, 6 & 8	C-465-2	
C-464, C-464-1			

Mounting Dimensions

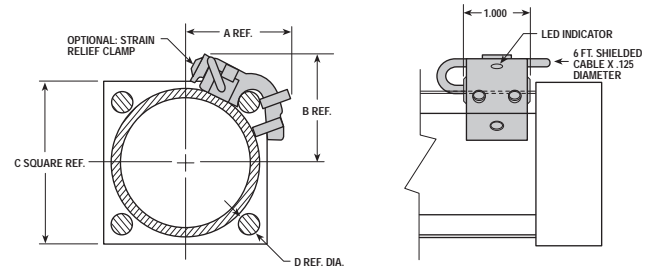

Bore Size	Letter Dimension			
	A	B	C	D
1 1/2"	1.375	1.500	2.000	.250
2"	1.500	1.750	2.500	.312
2 1/2"	1.750	1.875	3.000	.312
3 1/4"	2.000	2.187	3.750	.375
4"	2.375	2.500	4.500	.375
5"	3.000	3.125	5.500	.500
6"	3.375	3.375	6.500	.500
8"	4.000	4.125	8.500	.625

Quick Connect Option

All Low Profile Reed and Hall Effect Switches are available with quick connect cable option, shown by a (-1) after the standard switch part number (i.e. C-463-1).

NOTE: Quick connect switches do not include mating cable assembly. Order Part No. C-468.

Dimensions – Quick Connect

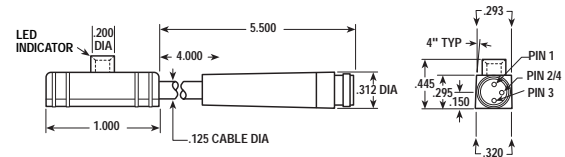

Quick Connector Cable Assembly – Part No. C468

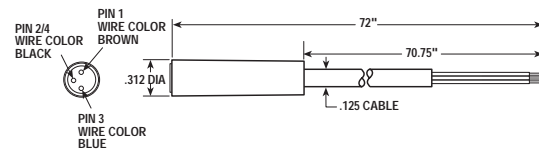

HYDRO-LINE Actuation Products



N5 SERIES CYLINDERS

- NFPA interchangeable
- **N5** – 3000 psi nominal hydraulic
- **AN5** – to 250 psi very heavy-duty pneumatic
- **LAN5** – to 250 psi very heavy-duty pneumatic – permanently lubricated
- All steel construction



R5 SERIES CYLINDERS

- NFPA interchangeable
- **A5/R5** – to 250 psi pneumatic
- **LA5/LR5** – to 250 psi pneumatic – permanently lubricated
- **HA5** – to 400 psi hydraulic
- **HR5** – 1500 psi nominal hydraulic



Q5 SERIES CYLINDERS

- NFPA interchangeable
- **Q5** – to 250 psi pneumatic
- **LQ5** – to 250 psi pneumatic – permanently lubricated
- **HQ5** – to 400 psi hydraulic
- Aluminum construction



HM SERIES CYLINDERS

- Conform to international metric specifications ISO 6020/2 and DIN 24 554
- 25 mm to 200 mm bore sizes
- 210 BAR nominal hydraulic
- All steel construction



ROCKFORD SERIES CYLINDERS

- ASAE interchangeable agricultural cylinders
- **Rockford 2500**–2500 psi hydraulic
- **Rockford 3000**–3000 psi hydraulic



ELECTRONIC FEEDBACK CYLINDERS

Hydraulic or pneumatic cylinders which incorporate cylinder position sensing and feedback throughout the stroke. Available in N5, R5, A5, Q5, HM, HW, SM or special cylinders.



SERIES 20/30 BOOSTERS

- Standard series to 5000 psi output
- Custom designs to 20,000 psi

T SERIES AIR/OIL TANKS

- All steel construction

QT SERIES AIR/OIL TANKS

- Aluminum end caps and translucent tubing



V5 SERIES CYLINDERS

- NFPA Interchangeable
- To 200 psi pneumatic
- Aluminum construction
- Now available in 5", 6" and 8" bore



HW SERIES CYLINDERS

- Welded construction
- 3000 psi nominal hydraulic



TSAYER CYLINDERS

- Threaded body construction
- To 200 psi pneumatic
- To 1000 psi nominal hydraulic



SM SERIES CYLINDERS

- Steel mill type construction
- **MSM**–2000 psi nominal hydraulic
- **HSM**–3000 psi nominal hydraulic
- **ASM**–Pneumatic



CUSTOM CYLINDERS

- Custom cylinders to meet special requirements
- Bores to 48"
 - Strokes to 300"
 - Pressures to 10,000 psi or higher



VISIT OUR WEB SITE:
www.hydro-line.com



830 MEREDITH WAY
SPARKS, NEVADA 89431 U.S.A.
702-355-7071 • FAX 702-355-7170

HIGHWAY 20 WEST • P.O. BOX 2068
DECATUR, ALABAMA 35602 U.S.A.
205-350-2603 • FAX 205-351-1264

HYDRO-LINE s.r.l.
VIA CAPRETTI 12/14
1-25136 STOCCHETTA BS, ITALY
(39)-030-201-6211 • (39)-030-209-1500

HEADQUARTERS

4950 MARLIN DRIVE • P.O. BOX 2045
ROCKFORD, ILLINOIS 61130 U.S.A.
815-654-9050 • FAX 815-654-3393

4908 HOVIS ROAD
CHARLOTTE, NORTH CAROLINA 28208 U.S.A.
704-394-0043 • FAX 704-394-0073

PATRICK GREGORY ROAD
WOLVERHAMPTON WEST MIDLANDS, WV11 3DZ U.K.
(0) 1902 304000 • FAX (0) 1902 305676



HYDRO-LINE, INC.

Delivering Engineered Solutions
in Actuation Worldwide

An IMC Company

REV. 7/98

5,000 CG