



Conduit Body Wire Pulling Instructions

IF964

The following procedures should be used to insure the reliability of wiring pulled through conduit bodies.

1. Use approved wire pulling compound that is compatible with wire insulation.
2. Start by pulling all the wires through one hub and train the wires through the cover opening.
3. Loop the wires in a large circle as shown on the attached sketch and feed through the other hub.
4. Pull all the wires together until the loop is approximately 6" in diameter for 2" trade size or less and 10 times the O.D. of the largest wire for 2½" trade size and larger.
5. Flip the loop 180° into a training loop. (Make sure the wires are not crossed.) Pull out the loop one wire at a time. It is best to start pulling out the training loop using the wires closest to the inside of the loop.

6. Do not pull the wires taut or any tighter than necessary to place the cover on the conduit body.
7. Station a person at the "training loop" to safely guide the wires during pulling. To prevent insulation damage use a blunt tool, if necessary, to keep the wire from binding or jamming. The use of a well rounded tool, such as a length of conduit or a round dowel, will assist in turning the loop while preventing damage to the wire insulation.

WARNING

Once the training loop is pulled out, release the tension on the wires.

To determine the maximum size and number of wires that can be safely pulled for a given Crouse-Hinds conduit body, refer to the table on the back of this instruction sheet.

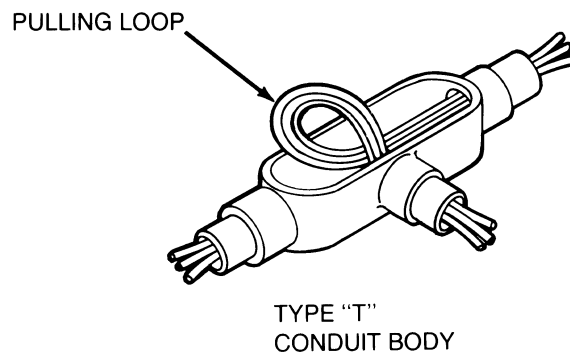
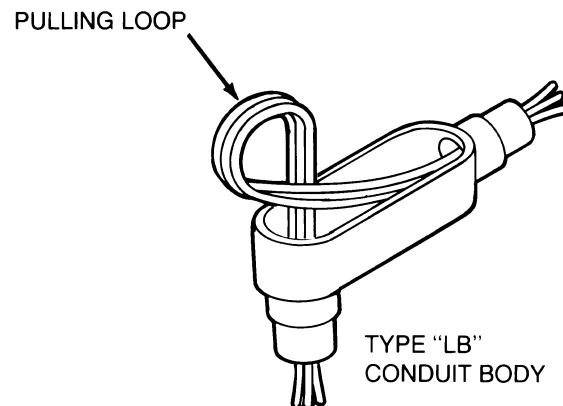
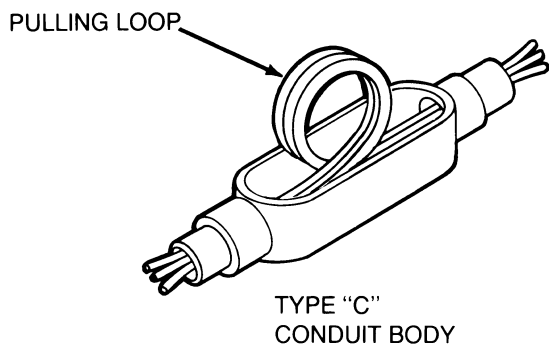

All statements, technical information and recommendations contained herein are based on information and tests we believe to be reliable. The accuracy or completeness thereof are not guaranteed. In accordance with Crouse-Hinds "Terms and Conditions of Sale", and since conditions of use are outside our control, the purchaser should determine the suitability of the product for his intended use and assumes all risk and liability whatsoever in connection therewith.

MAXIMUM NUMBER AND SIZE OF CONDUCTORS ALLOWED IN TRADE SIZES OF CROUSE-HINDS CONDUIT BODIES

Conduit Trade Size	Catalog Number	Hub*	Conductor Size AWG, MCM																	
			6	4	3	2	1	1/0	2/0	3/0	4/0	250	300	350	400	500	600	700	750	900
6"	LBD014	All	*	137	116	97	72	61	51	42	35	28	24	21	19	16	13	11	10	
5"	LBD012	All	*	93	79	66	49	41	34	28	23	19	16	14	12	10	3			
4"	BC10, BT10, C108, C1089, E108, LL107, LL108, LL1089, LR107, LR108, LR1089, T108, T1089, TB108, X108	All	*	59	50	42	31	26	21	17	14	11	10	3						
	T107, TB107, X107	Thru	*	59	50	42	31	26	21	17	14	11	10	3						
		Side	*	59	50	42	31	26	21	17	14	11	10	3						
	BLB10, BUB10, LB108, LBD10900, LB1089	All	*	59	50	42	31	26	21	17	14	11	10	8	7	3				
	LB107	All	*	59	50	42	31	26	21	17	14	11	10	3						
3-1 2"	LBNEC10	All	*	59	50	42	31	26	21	17	14	11	10	8	7	6	4	4	3	3
3-1 2"	BC9, BT9, C98, C989, E98, LL97, LL98, LL989, LR97, LR98, LR989, T98, T989, TB98, X98	All	*	46	38	32	24	20	16	13	11	9	7	3						
	LB97	All	*	46	38	32	24	20	16	13	11	9	3							
		Thru	*	46	38	32	24	20	16	13	11	9	3							
		Side	*	46	38	32	24	20	16	13	11	9	3							
	BLB9, BUB9, LB98, LBD9900, LB989	All	*	46	38	32	24	20	16	13	11	9	7	6	5	3				
	LBNEC9	All	*	47	39	33	25	21	17	14	12	10	8	7	6	5	4	4	3	
3"	C87	All	*	34	28	24	17	14	3											
	LB87	All	*	34	28	24	17	14	12	3										
		Side	*	34	28	24	17	14	12	3										
	C88, C889, E88, LL87, LR87, T88, T889, TB88, X88	All	*	34	28	24	17	14	12	10	8	3								
		Thru	*	34	28	24	17	14	3											
	TB87	Thru	*	34	28	24	17	14	3											
		Side	*	34	28	24	3													
	BC8, LB888, LB889, LL888, LL889, LR888, LR889	All	*	34	28	24	17	14	12	10	8	6	5	3						
	BLB8, BUB8, LBD8800	All	*	34	28	24	17	14	12	10	8	6	5	4	4	3				
	BT8	Thru	*	34	28	24	17	14	12	10	8	6	5	3						
		Side	*	34	28	24	17	14	12	10	8	6	3							
LBNEC8	All	*	34	28	24	17	14	12	10	8	6	5	4	4	3	3				
2-1 2"	C77	All	*	21	18	15	11	9	3											
	LB777	All	*	21	18	15	11	9	7	3										
		Thru	*	21	18	15	11	9	3											
	T77	Thru	*	21	18	15	11	9	3											
		Side	*	21	18	15	11	3												
	C78, C789, E78, LL777, LR777, T78, T789, TB78, X78	All	*	21	18	15	11	9	7	6	5	3								
BC7, BLB7, BT7, BUB7, LB78, LB789, LBD7700, LL78, LL789, LR78, LR789	All	*	21	18	15	11	9	7	6	5	3	3								
LBNEC7	All	*	22	19	16	12	10	8	7	6	4	4	3	3						
2"	C67, LB67	All	*	15	12	10	7	3												
	T67, TA67, TB67, X67	Thru	*	15	12	10	7	3												
		Side	*	15	12	3														
	L67, LB69, LL67, LR67	All	*	15	12	10	7	6	5	3										
	T68, TB68, X68	Thru	*	15	12	10	7	6	5	4	3									
		Side	*	15	12	10	7	6	5	3										
	BC6, BLB6, BT6, BUB6, C68, E68, LB68, LBD6600, LL68, LL69, LR68, LR69	All	*	15	12	10	7	6	5	4	3									
	T69	Thru	*	15	12	10	7	6	3											
Side		*	15	12	10	3														
C69	All	*	15	12	10	7	6	3												
1-1 2"	C57, T57, TA57, TB57, X57	All	*	8	7	3														
	BC5, BLB5, BT5, BUB5, C58, C59, E58, L57, LB58, LB59, LBD5500, LL57, LL58, LL59, LR57, LR58, LR59	All	*	8	7	6	4	3												
		T59	Thru	*	8	7	6	4	3											
			Side	*	8	7	3													
	T58, TB58, X58	Thru	*	8	7	6	4	3												
Side		*	8	7	6	3														
LB57	All	*	8	7	6	3														
1-1 4"	T47, TA47, TB47, X47	Thru	*	6	3															
		Side	*	6	5	3														
	C47, LB47, LB49	All	*	6	3															
1"	BC3, BLB3, BT3, BUB3, C37, C38, C39, E37, E39, L37, LB37, LB38, LB39, LB397, LBD3300, LL37, LL38, LL39, LR37, LR38, LR39, T37, T38, T39, T397, TA37, TA38, TB37, TB38, TB39, X37, X38, X39	All	*	3																
		3 4"	C27, C28, C29, E27, E29, L27, LB27, LB28, LB29, LB297, LBD2200, LL27, LL28, LL29, LR27, LR28, LR29, T27, T28, T29, TA27, TA28, TB27, TB28, TB29, X27, X28, X29	All	*															

NOTES:

Maximum Size of Conductors — Limited to sizes shown in above table.

Maximum Number of Conductors -

- Do not exceed quantities shown in above table when installing No. 4 AWG or larger conductors in a given Crouse-Hinds Conduit body.
- When installing No. 6 AWG or smaller conductors in conduit body, the maximum number permitted by N.E.C. Chapter 9, Tables 3A, 3B and 3C can be used.
- AWG wire sizes are based on Type XHHW insulation. When using other types of insulation, which may change the total cross-sectional area of the insulated conductor, consult Chapter 9 of the National Electrical Code to avoid exceeding recommended wire fills.

* "Side" hub refers to wiring that is pulled through one end hub and out a side hub. "Thru" hub refers to wiring that is pulled through one end hub and out the opposite end hub. "All" hubs refers to wiring pulled through any (side or thru) hub.