

TGC40 CABLE TRAY GROUNDING CLAMP

Installation and Maintenance Information
IF947 6/83



APPLICATION

Type TGC40 cable tray grounding clamps are used to securely clamp a grounding or bonding conductor to cable tray side rails.

The TGC40 clamp insures grounding continuity of the tray assembly when installed in compliance with Section 318-6 of the National Electrical Code® and any other applicable codes up to the maximum size grounding conductor marked on the TGC40 clamp.

INSTALLATION

1. Locate clamp body on the tray flange at least three inches from end of cable tray section as shown in Figure 1.
2. Holding clamp on the cable tray, tighten clamping screw securely until tray material deforms slightly (150 in. lb. torque).
3. Install grounding or bonding conductor into clamp and tighten pressure connector cap screw with Allen wrench to firmly grip conductor.

CAUTION

Use only copper, copper-clad aluminum or aluminum conductors sized in accordance with Section 250-79 of National Electrical Code.

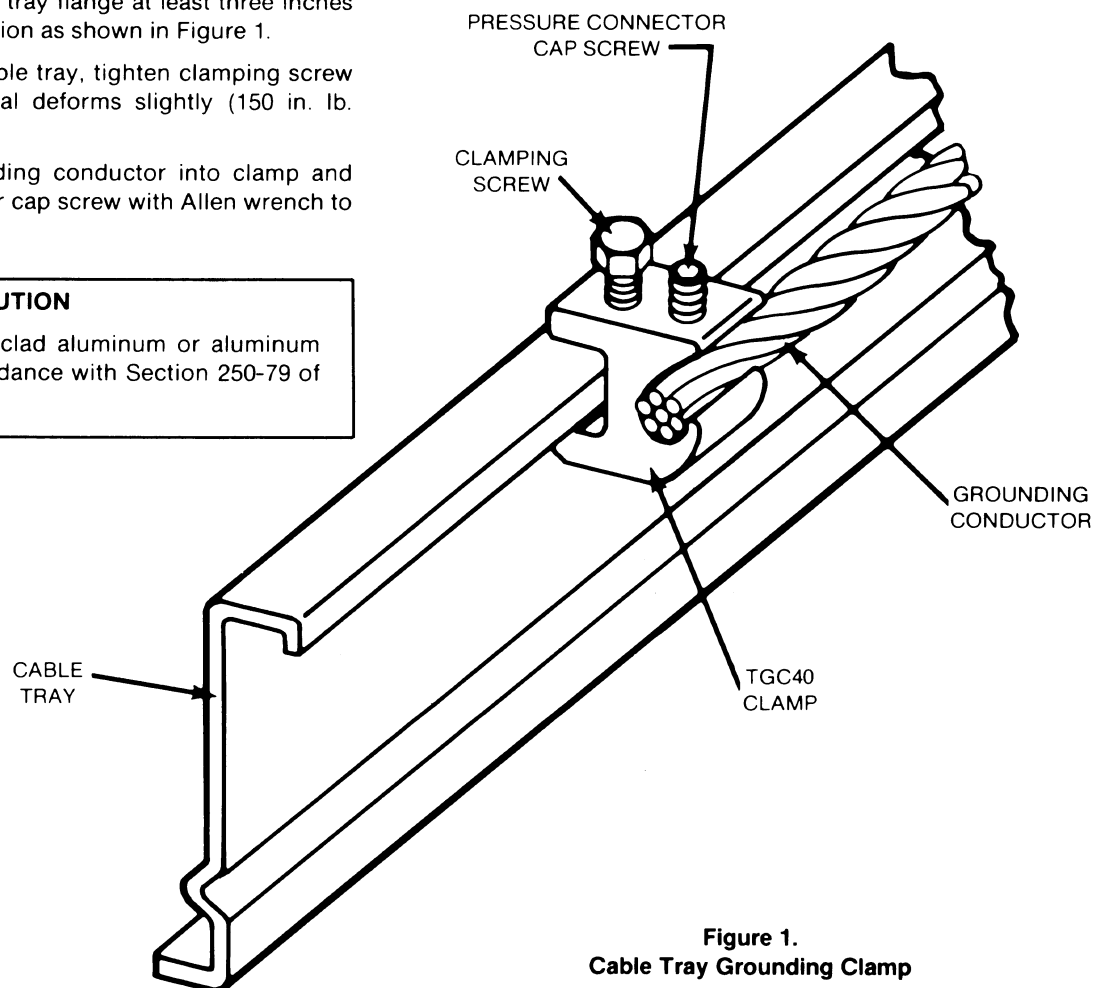

Figure 1.
Cable Tray Grounding Clamp

®National Electrical Code is a Registered Trademark of the National Fire Protection Association.

All statements, technical information and recommendations contained herein are based on information and tests we believe to be reliable. The accuracy or completeness thereof are not guaranteed. In accordance with Crouse-Hinds

"Terms and Conditions of Sale", and since conditions of use are outside our control, the purchaser should determine the suitability of the product for his intended use and assumes all risk and liability whatsoever in connection herewith.

This instruction sheet should be retained for future use in maintenance.