

TW THRU-WALL BARRIER

cable/conduit sealing device

2G

2G

Applications:

The THRU-WALL BARRIER® cable/conduit sealing device is used wherever there is a need to seal cables or conduits penetrating fire or non-fire rated walls, ceilings, floors, bulkheads or decks. For non-fire rated walls, ceilings, floors, bulkheads or decks, THRU-WALL BARRIER also restricts water and dust, and will help contain treated air. THRU-WALL BARRIER is designed:

- To provide a seal for cable/conduit penetrations through masonry, concrete or steel; to restrict the entrance of contaminants through cable/conduit penetrations into clean areas
- For use with most types of power, instrument and control cables, as well as conduits
- To be used indoors or outdoors, in new construction or existing structures

Features:

System:

- Few parts required to seal a wide range of diameters of cables or conduits
- Easy and fast installation, using factory assembled components
- High degree of flexibility with interchangeable sealing block assemblies and a selection of different sizes of frames

Mounting frame:

- One-piece cast malleable iron or steel mounting frame can be cast into concrete during wall construction, grouted in masonry surfaces or welded into steel bulkheads at any time
- Retrofit frame allows for easy installation of frame where cables/conduit are already installed
- Available in sizes to accommodate a wide range of cable tray sizes and loadings, including single and multiple layers of cables for power or instrument applications
- Cast keyways in mounting frame align and position sealing block assemblies
- Frames can be installed in wall such that sealing block assemblies can be inserted in either horizontal or vertical position

Sealing block assembly:

- Specially formulated elastomeric material between cast malleable iron pressure plates protects cable from mechanical damage; provides high pull-out resistance and positive cable separation; expands during fire to seal any voids left by burned cable insulation
- Interchangeable sealing block assemblies fit all THRU-WALL BARRIER mounting frames
- Cast stops on front pressure plate prevent sealing block assembly from slipping through mounting frame during installation
- Assemblies are offered for all cable/conduit outside diameters from 0.250" to 4.500" (6.4mm to 114.3mm); cables with diameters less than 0.250" can be accommodated – contact factory
- Sealing block openings will accommodate undersize and out-of-round cable
- Each sealing block assembly seals multiple cables/conduits; compact design permits close nesting of cables, saving space
- Reducers permit sealing block assemblies to accept cables with smaller O.D. than the specified range
- Plugs are used to fill unused openings in sealing block assemblies; blank sealing block assemblies fill unused spaces in mounting frames, providing for future expansion



Certifications and compliances:

- ASTM standard E-119
- NFPA 251
- UL classification per UL standard 1479
- NAVSEA approval – Electric Plant Installation Standard Methods No. S9300- AW-EDG-010/EPISM – TWFS/TWBS assemblies

Standard materials:

- Mounting frame – TWF, TWFR: cast malleable iron; TWFS: cast carbon steel, ASTM A27 grade 60-30
- Pressure plate – cast malleable iron
- Sealing material – special elastomeric material
- Clamping hardware – steel

Standard finishes:

- Malleable iron and hardware – electrogalvanized
- Steel – aluminized weldable paint
- Special elastomeric material – natural

Easy three-step installation:



1. Cast, grout or weld the one-piece mounting frame into masonry or steel surface.



2. Feed cables/conduit through the frame.

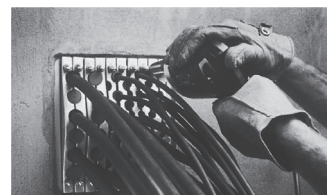

3. Position cables/conduit, insert factory assembled sealing blocks into keyways in mounting frame, and tighten nuts on clamping hardware to effect the seal.

TW THRU-WALL BARRIER

cable/conduit sealing device

Sealing block assemblies and mounting frames

Ordering information:

TWB sealing block assemblies

TWB sealing block assemblies are offered for cable/conduit outside diameters (O.D.) from 0.250" to 4.500" (6.4mm to 114.3mm). Cables with diameters less than 0.250" can be accommodated – contact factory. Each assembly opening will accommodate a 0.250" (6.4mm) O.D. range. When clamping hardware is tightened, the elastomeric material is uniformly compressed around all cable/conduits for a completely tight fit.

Sealing block assemblies are offered for use in marine applications. Each assembly has the required lubrication and sealing gaskets to meet U.S. Navy Hydrostatic Pressure Test Requirements. Assemblies for marine applications are available for cable/conduit O.D. from 0.250" (6.4mm) through 3.500" (88.9mm). To order, add suffix 'S' to TWB sealing block assembly catalog number. For example: TWBS4036.



TWB2063

Depending on opening size range, a standard sealing block assembly will seal from one to eleven cables

Opening size range	in. mm	0.250 - 0.500 6.4 - 12.7	0.500 - 0.750 12.7 - 19.1	0.750 - 1.000 19.1 - 25.4	1.000 - 1.250 25.4 - 31.8	1.250 - 1.500 31.8 - 38.1	1.500 - 1.750 38.1 - 44.5	1.750 - 2.000 44.5 - 50.8	2.000 - 2.250 50.8 - 57.2	2.250 - 2.500 57.2 - 63.5
No. openings in block		11 11 added ^A	6 11 added ^A	6	5	4	3	3	3	2
Cat. # Sealing block assembly		TWB2111 TWB1111	TWB2062 TWB2112	TWB2063	TWB3054	TWB3045	TWB30355	TWB4036	TWB40366	TWB5027
Frame spaces required		2 1	2 2	2	3	3	3	4	4	5
Cat. # Plug		TWP1		TWP3		TWP5		TWP6		TWP7
Cat. # Reducer ^C		-	TWR2	TWR3	TWR4	TWR5	TWR55	TWR6	TWR66	TWR7

TWF mounting frames

TWF(S) mounting frames may be installed either horizontally or vertically. TWFR retrofit frames are used wherever cables/conduits are already installed through a fire or non-fire rated wall, floor or ceiling. They are designed with a removable section to permit installation around cables/conduits. TWFR retrofit frames can be grouted into walls, floors or ceilings, or welded into steel bulkheads or decks. TWFR retrofit frames will perform in the same manner as the one-piece TWF(S) frames.

TWFS steel mounting frames are welded directly into steel bulkheads, decks and prepared sleeves. For marine applications, keeper bars are provided to securely hold TWBS sealing block assemblies in position when installed.

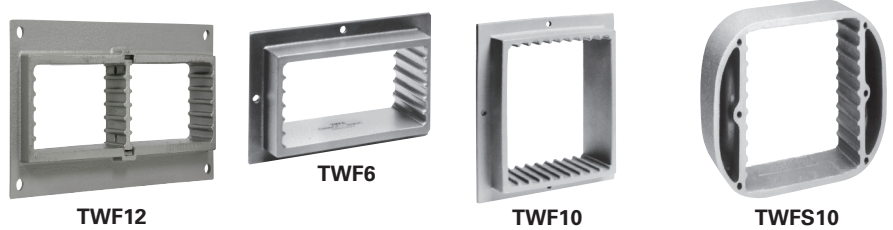

No. of spaces available	Cat. # Frame	Cat. # Retrofit frame	Cat. # Cast steel frame
6	TWF6	TWFR6	
10	TWF10	TWFR10	TWFS10
12	TWF12 ^C	TWFR12 ^C	
20	TWF20	TWFR20	TWFS20
24	TWF24	TWFR24	
30	TWF30	TWFR30	TWFS30

^A Catalog numbers TWB1111 and TWB2112 are used between TWB2111 and TWB2062 in cases where the number of cables to be sealed in 0.250 - 0.750 range exceeds the number of openings in standard assemblies. Use as many of these higher density assemblies as needed, sandwiched between halves of a standard assembly.

^B TWR reducers match TWB sealing block assemblies shown in column above catalog number and reduce openings to accept cable size ranges shown in adjacent column to the left (in direction of arrow).

^C Includes removable partition.

TW THRU-WALL BARRIER

cable/conduit sealing device

Parts and accessories

Ordering information:

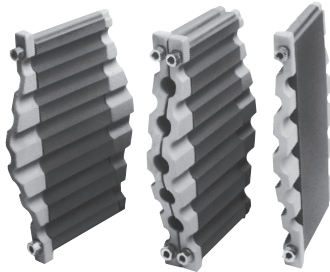

TWB2112 TWB2062

TWP plugs



TWP plugs will close any unused openings in sealing block assemblies. See table for plug catalog numbers which match specific sealing block assemblies.



TWR reducers



TWR reducers will reduce openings by 0.250" (6.4mm) in sealing block assemblies. See table for reducer catalog numbers which match specific sealing block assemblies.

More than one reducer can be used in a single opening.

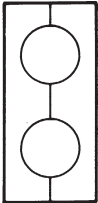
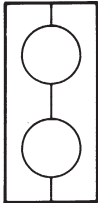
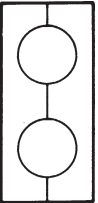
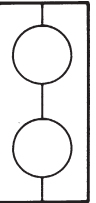
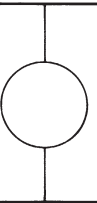
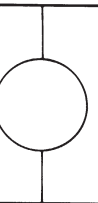
It is possible to increase cable fill density with double sided sealing block assemblies (TWB1111 and TWB2112) sandwiched between halves of a standard assembly.

Opening size range	in. mm	2.500 - 2.750 63.5 - 69.9	2.750 - 3.000 69.9 - 76.2	3.000 - 3.250 76.2 - 82.6	3.250 - 3.500 82.6 - 88.9	3.500 - 4.250 [ⓐ] 101.6 - 108.0	4.250 - 4.500 108.0 - 114.3	Blank – no openings	
No. openings in block		2	2	2	2	1	1	None	None
Cat. # Sealing block assembly		 TWB50277	 TWB5028	 TWB60288	 TWB6029	 TWB7011010	 TWB70111	 TWB1	 TWB3
Frame spaces required		5	5	6	6	7	7	1	3
Cat. # Plug		TWP7	TWP8		TWP9	TWP10	TWP11	-	
Cat. # Reducer [ⓑ]		TWR77	TWR8	TWR88	TWR9 TWR99	TWR1010 TWR10	TWR11	-	

TWB closure cover kits

TWB closure cover kits offer an optional method to close TWB frames installed for future expansion or those that are abandoned. Closure cover kits include two covers clamped to opposite sides of the frame with hardware provided. The insulating material provided is sandwiched between the two covers to maintain the fire rating of the assembly.

No. of spaces available	Cat. # [ⓑ]
6	TWB600 [ⓑ]
10	TWB1000
12	TWB600 [ⓑ]
20	TWB2000
24	TWB2400
30	TWB3000

TWK anchors

TWK anchor assemblies are used to attach mounting frames to wall, ceiling or floor when grouting in frames.

Mounting type	Cat. #
Flush	TWK1
Recessed	TWK2

[ⓐ]For 3.5" - 4" cable/conduit, use TWB7011010 assembly and reduce down using TWR reducers.

[ⓑ]TWR reducers match TWB sealing block assemblies shown in column above catalog number and reduce openings to accept cable size ranges shown in adjacent column to the left (in direction of arrow).

[ⓑ]TWB closure cover kits are not designed to provide a watertight seal in marine/shipboard applications or wash down areas. One kit seals one unused frame opening of same size. Example: use one (1) TWB2000 kit to seal one (1) TWB20 or TWFR20 frame.

[ⓑ]Use two (2) TWB600 kits to seal one TWB12 or TWFR12 frame opening.

TW THRU-WALL BARRIER

cable/conduit sealing device

Ordering example A

Product information:

Selecting and specifying THRU-WALL BARRIER components is a simple procedure. Primary components for the THRU-WALL BARRIER consist of TWF mounting frames in various sizes and TWB sealing block assemblies for cable/conduit outside diameters (O.D.) in 1/4 inch increments from 0.250" to 4.500" (6.4mm to 114.3mm). Cables with diameters less than 0.250" can be accommodated – contact factory.

Cable/conduit sizes can be mixed within a sealing block assembly by inserting TWR reducers to accommodate smaller diameters. The use of reducers can decrease the number of sealing block assemblies required. More than one reducer can be used in a single opening.

Another way to increase density is to use TWB1111 and TWB2112 sealing block assemblies wherever there is a large number of cables/conduits in sizes ranging from 0.250" to 0.750."

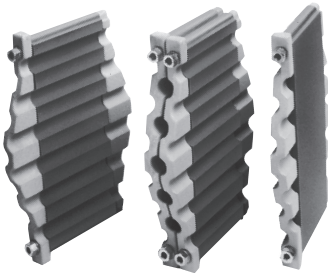

TWB2062 TWB2112 TWB2062

Shown here is a double sided sealing block assembly (TWB2112) sandwiched between halves of a standard sealing block assembly (TWB2062). Additional double sided sealing block assemblies may be used to accommodate larger quantities of cables or conduits.

Unused sealing block openings must be closed with TWP plugs. Blank sealing block assemblies TWB1 and TWB3 are used to fill each unused space in the mounting frame and permit future expansion of the system. Typical practice is to include space allowance of 20 to 50% for future expansion. TWF closure kits are used to seal entire frames and permit future system expansion.

Specifying and ordering:

The selection of components is based on the quantity and sizes of cables or conduits going through the penetrations. Once these are known, the sealing block assemblies and frames can be selected.

Step 1. Group cables/conduits by outside diameter (O.D.) and rank from the largest to the smallest.

Step 2. Keeping in mind that sealing block assemblies are available in one-quarter inch increments, group cables/conduits that fall within the same sealing block assembly O.D. size range.

Step 3. Starting with the largest cable/conduit O.D., select the sealing block assemblies required. All openings in each sealing block assembly must be filled.

Specify TWR reducers to accommodate smaller diameter cables, where possible, and TWP plugs to fill openings not used.

Step 4. Total the frame spaces required for the specified sealing block assemblies and select an appropriate mounting frame(s). Frames are available in 6, 10, 12, 20, 24 and 30 space sizes. Keep future expansion requirements in mind when specifying frame. Specify blank sealing block assemblies to fill unused mounting frame space and TWB closure cover kits to fill unused frames.

Step 5. Check specification/order to be sure it includes 1) frames, 2) sealing block assemblies, 3) plugs and 4) reducers.

Ordering example A:

Cable tray size: 24"

Cables specified: 5 power cables – sizes ranging from 1.960" to 2.200" O.D.

Spare capacity required: 50%

Step 1. Group cables by O.D. and rank from largest to smallest.

	Cable qty.	Cable O.D.
	4	2.200
	1	1.960
Total	5	

Step 2. Group cables that fall within the same sealing block assembly size.

	Cable qty.	Sealing block O.D. range
	4	2.000 - 2.250
	1	1.750 - 2.000
Total	5	

Step 3. Starting with the largest cable O.D., select the quantity of sealing block assemblies required. Specify TWR reducers to accommodate smaller diameter cables where possible and TWP plugs to fill openings not used (see example A diagram).

Note: In the example, one (1) TWR66 reducer is required to accommodate the cable with 1.960 O.D. and one (1) TWP6 plug is required for the unused opening.

Step 4. Total the frame spaces required for sealing block assemblies and select appropriate size mounting frame. Factor in spare capacity required for future expansion.

Total frame spaces required	8
Specification requires 50% spare capacity	4
Total spaces	12

Selection: One TWF12 mounting frame with capacity of 12 spaces. Four TWB1 blank sealing block assemblies to fill unused frame space. (Choice of frame could vary based on future expansion needs and/or specific cable arrangement).

Cat. # Sealing block assembly	O.D. range	No. of openings	Cables to be sealed	No. of openings	Cables to be sealed
TWB40366	2.000 - 2.250	3	3	-	4
TWB40366	2.000 - 2.250	3	2	1	4
Totals		6	5	1	8

Step 5. Bill of materials for specification/order should read:

- (1) TWF12
- (2) TWB40366
- (4) TWB1
- (1) TWR66
- (1) TWP6

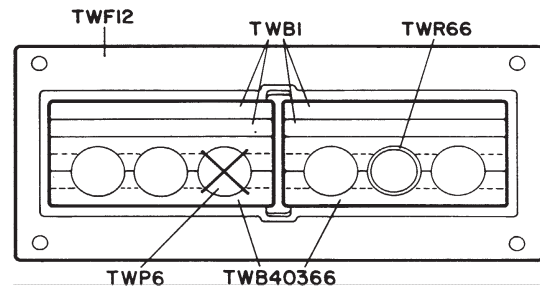

Example A diagram

TW THRU-WALL BARRIER cable/conduit sealing device

Ordering example B

Ordering example B:

Cable tray size: 24"

Cables specified: 6 power cables – sizes ranging from 2.140" to 2.180" O.D.; 31 control cables – sizes ranging from 0.550" to 0.945" O.D.

Spare capacity required: 25%

Step 1. Group cables by O.D. and rank from largest to smallest.

Cable qty.	Cable O.D.
4	2.180
2	2.140
1	0.945
4	0.890
7	0.700
9	0.637
10	0.550
Total	37

Step 2. Group cables that fall within the same sealing block assembly size.

Cable qty.	Sealing block O.D. range
6	2.000 - 2.250
5	0.750 - 1.000
26	0.500 - 0.750
Total	37

Step 3. Starting with the largest cable O.D., select the quantity of sealing block assemblies required. Specify TWR reducers to accommodate smaller diameter cables, where possible, and TWP plugs to fill openings not used (see example B diagram).

Cat. # Sealing block assembly	O.D. range	No. of openings	Cables to be sealed	Openings not used	Frame spaces required
TWB40366	2.000 - 2.250	3	3	-	4
TWB40366	2.000 - 2.250	3	3	-	4
TWB2063	0.750 - 1.000	6	5	1	2
TWB2062	0.500 - 0.750	6	6	-	2
TWB2112	0.500 - 0.750	11	11	-	2
TWB2112	0.500 - 0.750	11	9	2	2
Totals		40	37	3	16

Note: In this example, two (2) TWB2112 sealing block assemblies are sandwiched between two halves of a TWB2062. This dramatically increases cable density in minimum frame space. One (1) TWP3 plug is required for unused opening in TWB2063 and two (2) TWP1 plugs are required for unused openings in the TWB2112.

Step 4. Total the frame spaces required for sealing block assemblies and select appropriate size mounting frame(s). Factor in spare capacity required for future expansion.

Total frame spaces required	16
Specification requires 25% spare capacity	4
Total spaces	20

Selection: Two TWF10 (or one TWF20) mounting frames with total capacity of 20 spaces. One TWB3 and one TWB1 blank sealing block assembly to fill unused frame space. (Choice of frame could vary based on future expansion needs and/or specific cable/conduit arrangement).

Step 5. Bill of materials for specification/order should read:

- (2) TWF10 or (1) TWF20
- (2) TWB40366
- (1) TWB2063
- (1) TWB2062
- (2) TWB2112
- (1) TWP3
- (2) TWP1
- (1) TWB3
- (1) TWB1

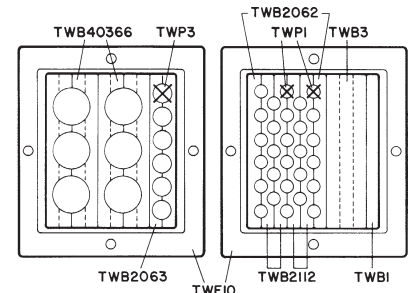

Example B diagram

Note: For TWFS mounting frame hole dimensions, contact factory or your local Eaton's Crouse-Hinds Division sales representative.

Dimensions (in inches):

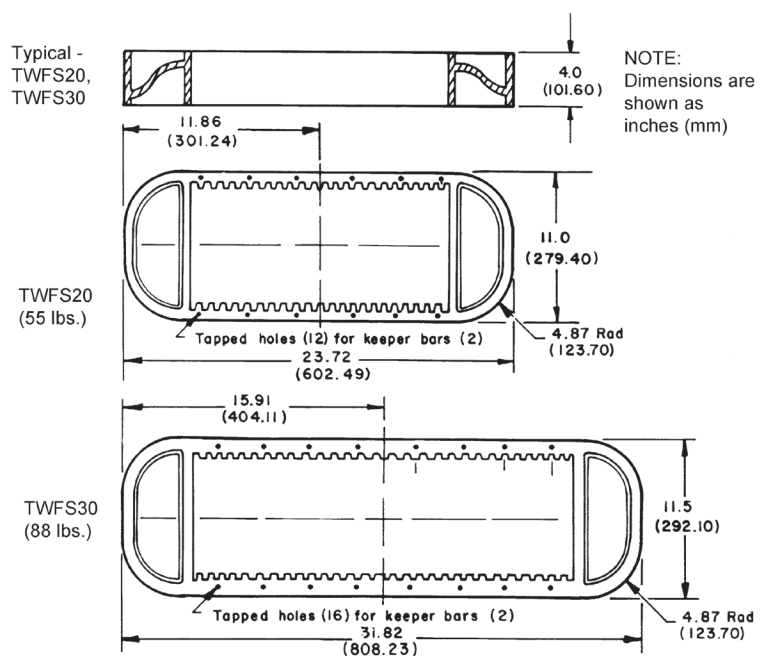
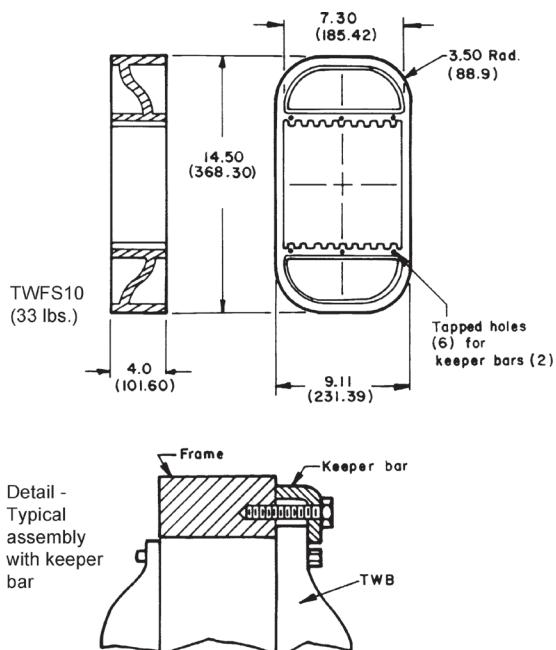

TW THRU-WALL BARRIER

cable/conduit sealing device

2G

2G **Dimensions[Ⓜ] (in inches):**

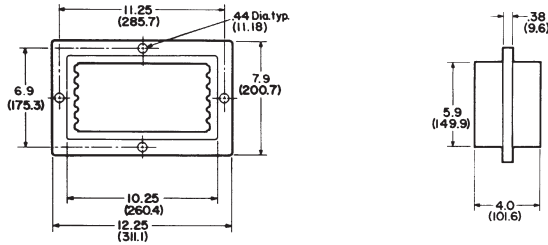

TWF6 (20 lbs.)

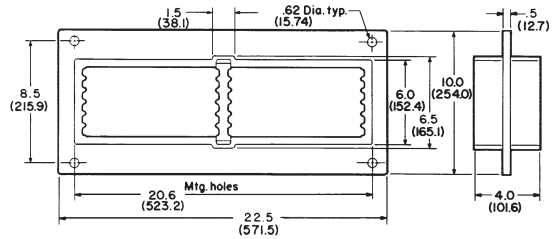

TWF12 (38 lbs.)

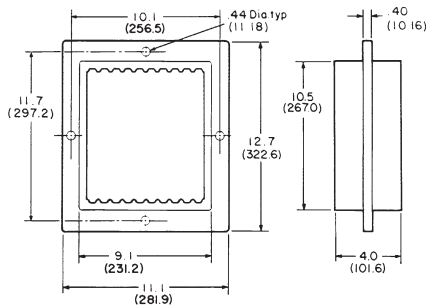

TWF10 (25 lbs.)

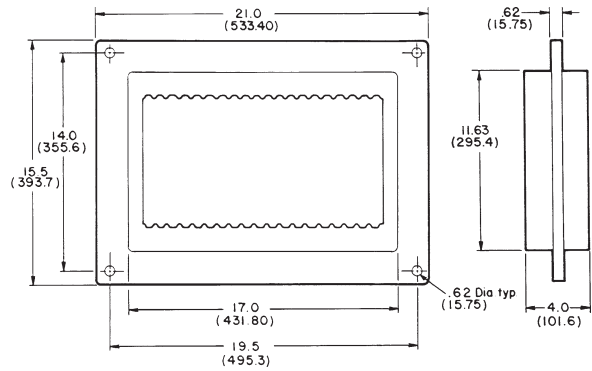

TWF20 (82 lbs.)

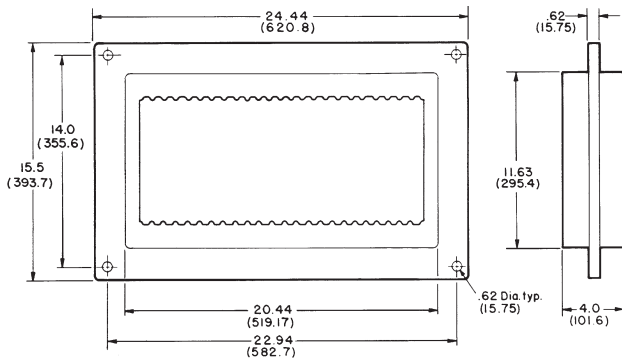

TWF24 (88 lbs.)

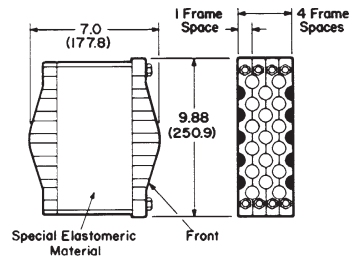

TWF

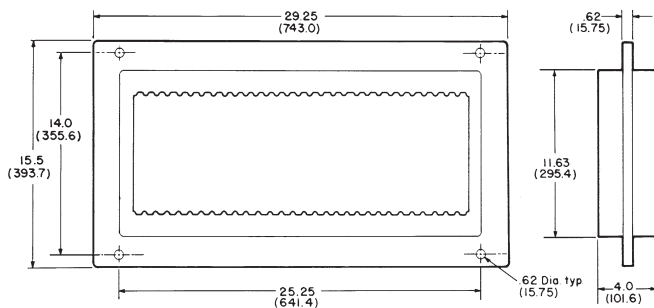

TWF30 (97 lbs.)

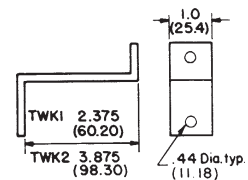

TWK

Note: Dimensions shown for TWF frames also apply for TWFR retrofit frames.

[Ⓜ]For TWF mounting frame hole dimensions, contact factory or your local Eaton's Crouse-Hinds Division sales representative.