

Haz

HazJbx HFS/wd

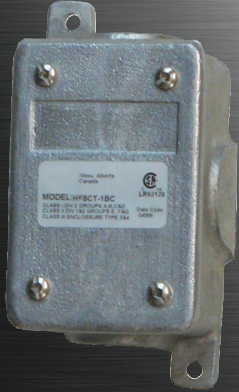

FEATURES

- Heavy wall construction.
- Field installation of terminal block.
- Field drilling and tapping.
- Rear NPT entry available.
- Two heavy duty mounting pads.
- Grounding lug with cast in slots for wire retention.
- Neoprene gasket resists petroleum and provides a watertight seal.
- Raised hub height allows for easy installation of cable glands.

APPLICATIONS

- Hazardous locations
- Grain & sugar milling processing & storage
- Petrochemical facilities
- Marine and watertight requirements
- Oil and gas exploration and production
- Waste water treatment plants
- Pipeline compressor / pumping & storage
- Food & beverage processing facilities
- Coal processing & storage
- Munitions manufacturing & storage

APPROVALS

- Class I Division 2 Groups A, B, C, & D
- Class I Zone 2 Groups IIA, IIB & IIC
- Class II Divisions 1 & 2 Groups E, F & G
- Class III
- Type 4
- Conforms to IP66
- ABS

STANDARDS

- UL 1604 - Electrical Equipment for Class I & II Division 2 & Class III
- UL 1203 - Explosive And Dust Ignition Proof
- CSA Class 4418 02
- CSA Class 4418 82

TECHNICAL SPECIFICATIONS

BOX/COVER

Cast copper free aluminum.

HARDWARE

Stainless steel.

GASKET

One piece neoprene.

ENTRIES

See ORDERING REFERENCES.

MOUNTING

Surface via two maximum 1/4" mounting bolts (not included).

ORDERING REFERENCES

PART NUMBER	ENTRY SIZE	ENTRY LOCATION	WEIGHT	
			LBS	KG
HFSC-1BC	1/2"	Through-feed	1.75	0.79
HFSC-2BC	3/4"	Through-feed	1.75	0.79
HFST-1BC	1/2"	Tee	1.75	0.79
HFST-2BC	3/4"	Tee	1.75	0.79
HFSX-1BC	1/2"	4 Way	1.75	0.79
HFSX-2BC	3/4"	4 Way	1.75	0.79

Note: Consult factory for other Entry Options.

SPARE PARTS

Part No.	Description
HFSBC	Blank Cover With Gasket & Screws
FSRG	Box Cover Gasket

DIMENSIONS

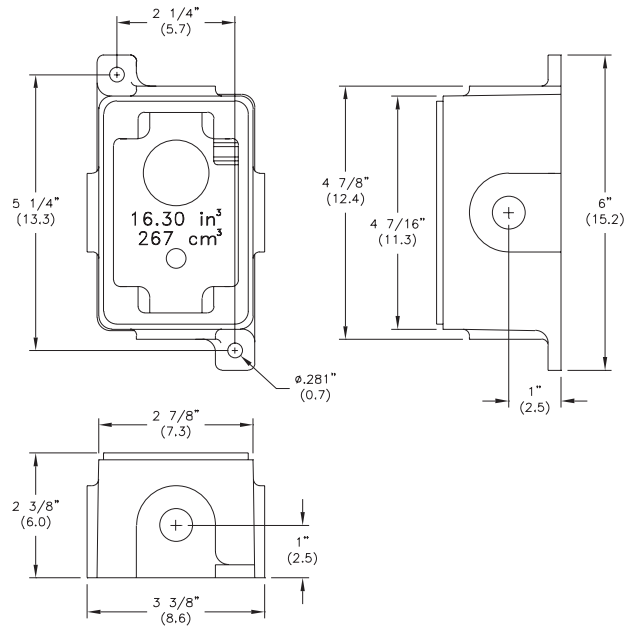

Dimensions in inches (cm)