

CM 21000



**Warning**

Forward this manual the person responsible for Installation, Operation and Maintenance of the product described herein. Without access to this information, faulty Installation, Operation or Maintenance may result in personal injury or equipment damage.

# Installation, Operation and Maintenance of Airflex<sup>®</sup> CM Marine Clutch



**Caution:**

**Use Only Genuine Airflex Replacement Parts**

The Airflex Division of Eaton Corporation recommends the use of genuine Airflex replacement parts. The use of non-genuine Airflex replacement parts could result in substandard product performance, and may void your Eaton warranty. For optimum performance, contact Airflex:

In the U.S.A. and Canada: (800) 233-5890

Outside the U.S.A. and Canada: (216) 281-2211



**November, 1994  
204091**

Copyright Eaton Corp. 1994 All rights reserved.

## **Table of Contents**

1.0 INTRODUCTION . . . . .	2
1.1 Description . . . . .	2
1.2 How it Works . . . . .	2
2.0 INSTALLATION . . . . .	3
2.1 Mounting Considerations . . . . .	3
2.2 Mounting Spider and Drum Hub . . . . .	3
2.3 Installation of Element and Drum - Gap Mounted Arrangement . . . . .	3
2.4 Air Control System . . . . .	4
3.0 OPERATION . . . . .	4
3.1 Torque, RPM and Pressure Limits . . . . .	4
3.2 Alignment . . . . .	5
4.0 MAINTENANCE . . . . .	5
4.1 Periodic Inspection . . . . .	5
4.2 Friction Lining Replacement . . . . .	7
5.0 SPARE PARTS STORAGE . . . . .	7
5.1 Element Assemblies . . . . .	7
5.2 Drums . . . . .	7
6.0 ORDERING INFORMATION/TECHNICAL ASSISTANCE . . . . .	8
7.0 DRUM SELECTION . . . . .	8
8.0 ELEMENT PARTS LIST . . . . .	9

**FIGURE 1 - COMPONENT PARTS FOR AIRFLEX  
TYPE CM ELEMENT**

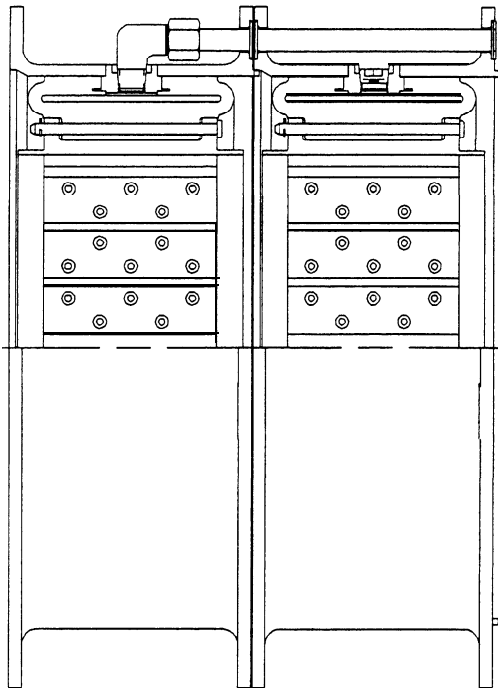
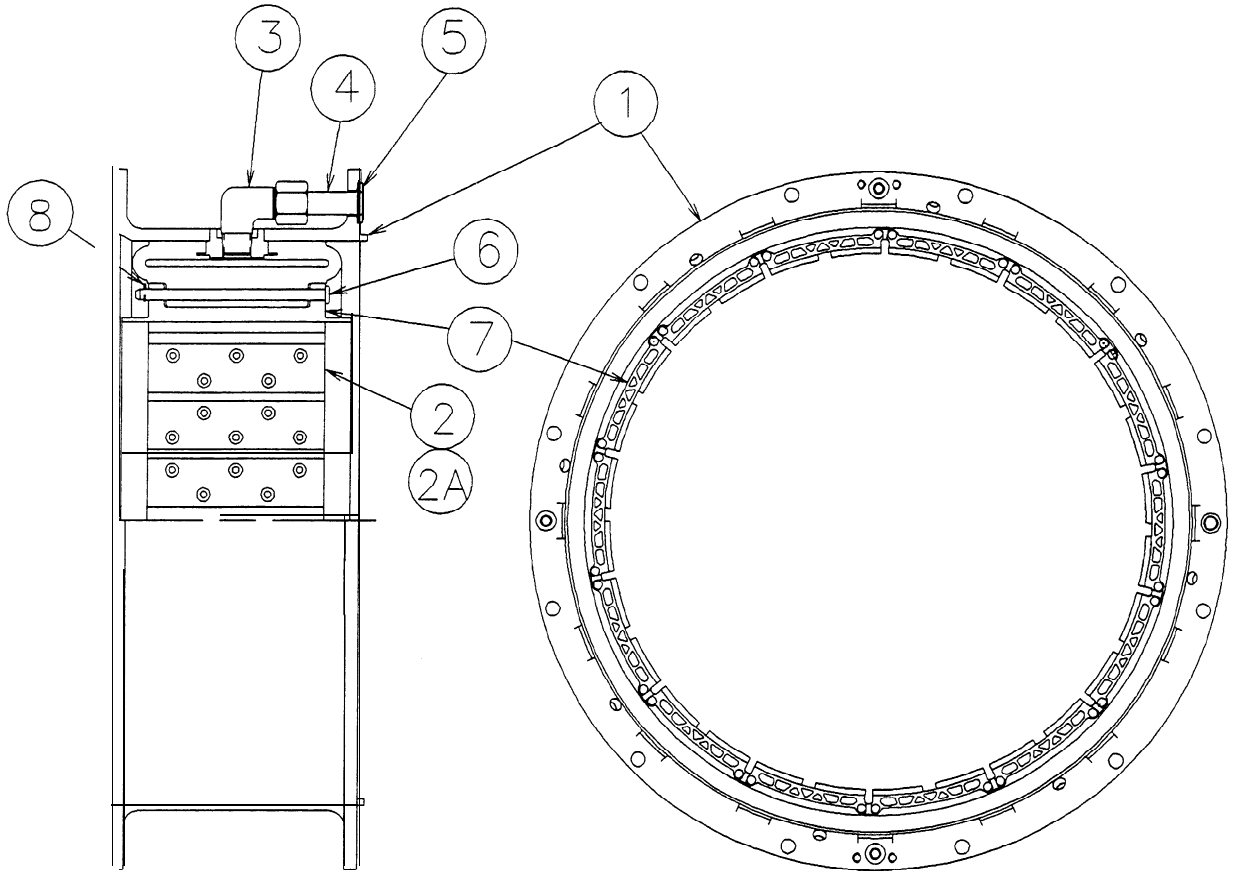

**DUAL MOUNTED**

ITEM	DESCRIPTION
1	Rim and Tube Assembly
2	Replacement Friction Lining
2A	Rivets
3	Elbow Assembly
4	Air Connection Tube
5	Air Connection Gasket
6	Shoe Pin
7	Friction Shoe Assembly
8	Cotter Pin

# 1 .0 INTRODUCTION

Throughout this manual there are a number of **HAZARD WARNINGS** that must be read and adhered to in order to prevent possible personal injury and/or damage to the equipment. Three signal words “**DANGER**”, “**WARNING**”, and “**CAUTION**” are used to indicate the severity of the hazard, and are preceded by the safety alert symbol .



Denotes the most serious injury hazard, and is used when serious injury or death **WILL** result from misuse or failure to follow specific instructions.





Used when serious injury or death **MAY** result from misuse or failure to follow specific instructions.



Used when injury or product/equipment damage may result from misuse or failure to follow specific instructions.

It is the responsibility and the duty of all personnel involved in the installation, operation and maintenance of the equipment on which this device is used to fully understand the

 **Danger:** ,  **Warning:** and  **Caution:** procedures by which hazards are to be avoided.

## 1.1 Description

- 1.1.1 The Airflex air-actuated CM element assembly is designed and manufactured to provide dependable clutch service in a multitude of marine and industrial applications. The ventilated construction is suited for heavy duty operations where moderate slippage is encountered. All torque load is carried through the neoprene and cord actuating tube which assists in absorbing damaging shock loads. The Airflex CM element assembly requires no lubrication or adjustment.
- 1.1.2 All Airflex CM element assemblies are supplied with NON-ASBESTOS friction material.

- 1.1.3 The Airflex CM element assemblies are available in 5 sizes which are identified by the drum diameter in inches on which they constrict and the width in inches of its friction lining. For instance, size 26CM475 is designed to constrict on to a 26 inch (660 mm) diameter drum and has a friction lining width of 4.75 inches (121 mm). The smallest CM element will constrict on a 26 inch (660 mm) diameter drum and the largest on a 48 inch (1219 mm) drum.
- 1.1.4 Individual elements can be bolted together to form dual elements having twice the torque capacity of a single element.
- 1.1.5 CM elements have gained popularity as marine propulsion clutches. In this arrangement, one element of a dual mounted unit drives through a drum and drum hub attached to a gearbox pinion and functions as the ahead (forward) clutch, the other element drives through a gear shaft drum and drum hub and spacer and functions as the astern (reverse) clutch. A manifold is bolted to the outboard end of the element to serve as an inlet for the required air supply and connection to the engine flywheel.

## 1.2 HOW IT WORKS

- 1.2.1 Referring to Figure 1, CM construction consists of a neoprene and cord tube which is bonded to the outer steel Rim (1). The rim has male and female registers which permit the element to be easily assembled into a dual arrangement. This register combination accurately locates the CM element to the driving component. Drilled holes are located in the flange of the rim, which allow for simple mounting to an adapter flange or spider.
- 1.2.2 As air pressure is applied to the air actuating tube, the tube inflates, forcing the ventilated Friction Shoe Assemblies (7) uniformly inward against the drum which is attached to the driven component. As actuating air is exhausted, the resiliency of the tube, aided by centrifugal force, retracts the shoes, resulting in total disengagement.
- 1.2.3 Ventilated friction shoes are attached to the tube by Shoe Pins (6) which in turn are held into position by Cotter Pins (8). Rubber lugs on the inside diameter of the actuating tube fit into recesses in the friction shoe backing plate providing a positive interface between the shoe and tube.

--A--

## 2.0 INSTALLATION

### 2.1 Mounting Considerations

- 2.1.1 Refer to the Airflex assembly drawing or the machinery maintenance manual for installation procedures for the specific CM application being installed. Following are some general guidelines for installation of the CM marine clutch.

#### **Caution:**

Oil or grease contamination will result in a reduction of developed clutch torque. Either of these conditions will result in clutch slippage and/or overheating.

#### **Caution:**

All rotating equipment must be guarded to comply with applicable safety standards.

- 2.1.2 Clutch shaft alignment must be within the tolerances indicated in the alignment section 3.2.2 of this manual.
- 2.1.3 All mounting fasteners must be of the proper size and grade, and tightened to the value shown on Table 1. Use self locking nuts or lockwashers.

### 2.2 Mounting Spider and Drum Hub

NOTE: The drum hub and spider (adapter flange) are unique to each individual application and are identified on the drawing.

- 2.2.1 The spider and drum hub are bored for a press fit onto their respective shafts. The interference is approximately .0005 in. per inch (0,0005mm/mm) of shaft diameter.

TABLE 1		
Fastener Size & Assembly Torque		
Model	Size	Torque Ft-Lb (Nm)
26CM475	5/8-11NC	77 (104)
30CM500 35CM500 40CM550 48CM650	3/4-10NC	93 (126)

NOTE: All fasteners must be Grade 5 or better.

- 2.2.1.1 Ensure the shaft is clean and free of nicks or burrs and check the shaft and bore diameters for proper fit.
- 2.2.1.2 Tap the key into the keyway, making sure it bottoms.
- 2.2.1.3 Apply a light coat of anti-seizing compound to the shaft and key.
- 2.2.1.4 Heat the drum hub or spider uniformly to 250°F (121° C) to expand the bore.

#### **Caution:**

It is recommended the drum hub or spider be heated in oil or an oven; however, since this is not always possible, torches may be used. When using torches, use several with "rosebud" (broad-flame) tips and keep them moving, starting from the outside moving inward, to avoid "hot spots". Check bore temperature frequently to avoid overheating.

- 2.2.1.5 Slide the heated drum hub or spider onto the shaft to the position indicated on the assembly drawing or specific machinery manual. Hold in position and allow to cool.

### 2.3 Installation of Element and Drum - Gap Mounted Arrangement

NOTE: Insure that all mating surfaces are clean and free of paint, corrosion, burrs, ect., prior to mounting.

- 2.3.1 Note the orientation of the drum flange with respect to the air connection on the element and slide the drum into the element.
- 2.3.2 Separate the shafts as far as the bearing clearances will allow and hoist the element/drum into position.
- 2.3.3 Attach the drum to the drum hub with the appropriate fasteners(see table I). Make sure the bore in the drum flange fully engages the pilot on the drum hub. Torque and tighten evenly to the value in table 1.
- 2.3.4 Apply a small amount of pliable gasket cement to the air connection gaskets to hold them in position during installation. Install the air connection gasket onto the air tube. See Figure 2.

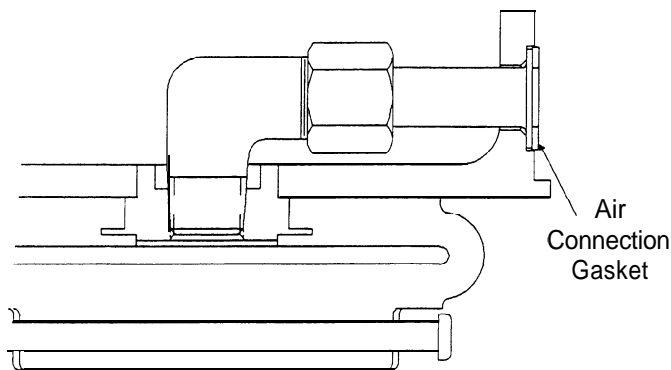

Figure 2

- 2.3.5 Align the element air connection with the passage in the spider and attach the element to the spider with the appropriate fasteners. See table. Make sure the element fully engages the register in the spider. Tighten fasteners in an even crosswise pattern to the value shown in table 1.

## 2.4 Air Control System



**Caution:**  
Maximum applied air pressure is 150 psig (10,3 bar). Operation at pressures **exceeding** 150 psig (10,3 bar) may result in damage to the element.



**Caution:**  
Do not inflate the element without having a drum in place. Inflation of the element without a drum in place will result in permanent damage to the element components.

- 2.4.1 Since the air control system used will be dependent on the specific application, a detailed description cannot be made in this manual. Following are some general guidelines for installing and adjusting air controls.
- 2.4.2 The air receiver tank must be located within five feet of the rotor seal.
- 2.4.3 Use full size piping and valves consistent with the rotor seal size.
- 2.4.4 Keep the number of elbows to a minimum.

- 2.4.5 Use poppet-type solenoid valves. Spool valves are not recommended.
- 2.4.6 An air line lubricator is not required for the element; however, if one is used, it must be a non-adjustable, mist-type
- 2.4.7 If a flow control valve is used, it must have free flow (indicated by an arrow on the valve body) directed away from the element.
- 2.4.8 The final connection to the rotor seal **MUST** be made with flexible hose and place no radial load upon the rotor seal.



**Caution:**  
Do not use rigid pipe at the connection to the rotor seal. Rigid piping will result in excessive loads on the rotor seal bearings, shortening life.

## 3.0 OPERATION



**Warning:**  
Exceeding operating limits described in this section may result in personal injury or equipment damage.



**Caution:**  
All rotating equipment must be guarded to comply with applicable safety standards.

### 3.1 Torque, RPM and Pressure Limits

- 3.1.1 The developed torque is dependent upon the applied air pressure and operating speed. If the developed torque seems inadequate, check for oil, grease or dust contamination or excessive wear.



**Danger:**  
Do not exceed the operating speeds shown in Table 2. Operation at speeds greater than allowable will result in permanent damage to the element, personal injury or death.

TABLE 2	
Maximum Safe Operating Speeds	
Size	Maximum RPM
26CM475	1030
30CM500	915
35CM500	790
40CM550	700
48CM650	605

 **Caution:**

Maximum applied air pressure is 150 psig (10,3 bar). Operation at pressures exceeding 150 psig (10,3 bar) may result in damage to the element.

 **Caution:**

The non-asbestos friction material used in Airflex CM elements may not develop rated torque initially. A short “wear in” is required. Clutch operation should be monitored closely to prevent excessive heat generation from slippage.

3.1.2 Maximum safe operating speeds are shown in Table 2.

### 3.2 Alignment

 **Caution:**

When the CM element is used for marine applications, consult gear drive and/or Engine manufacturer installation and alignment publications.

 **Caution:**

Operation with shaft misalignment exceeding alignment limits will result in accelerated wear of the element components. Severe misalignment will result in excessive vibration and/or overheating when disengaged due to dragging of the friction shoes.

#### 3.2.1 PARALLEL ALIGNMENT TOLERANCE :

Not to exceed .010 inch (0,254mm) Total Indicator Reading .005 inch (0,127mm) maximum offset.

#### 3.2.2 ANGULAR ALIGNMENT TOLERANCE :

Not to exceed .0005 inch per inch (0,0005mm/mm) diameter at which readings are taken.

## 4.0 MAINTENANCE

 **Warning:**

Only qualified personnel should install, adjust or repair these units. Faulty workmanship will result in exposure to hazardous conditions personal injury and/or equipment damage.

 **Warning:**

Prior to removal of the clutch , make sure the machinery is in, and will remain in, a safe condition.

 **Caution:**

When replacing components, use only genuine Airflex replacement parts. Use of other materials may severely affect performance.

 **Caution:**

For marine gearbox installation or removal, check the gearbox manual for recommended procedures.

### 4.1 Periodic Inspection

NOTE :Airflex CM elements are completely self adjusting and automatically compensate for lining and drum wear. Lubrication is not required.

- 4.1.1 The following items may be inspected without disassembly of the element.
  - 4.1.1.1 Air Control Components - Check for proper adjustment of the air control components. Make sure the safety pressure switches, if used, are set correctly. Repair any air leaks.
  - 4.1.1.2 Inspect the friction lining for signs of wear, if evident see section 4.2.

**! Caution:**

Operation with friction material worn to less than minimum allowable thickness will result in damage to the drum.

- 4.1.1.3 Contamination of Shoes or Drum and element with oil or grease will reduce the developed torque of the clutch or brake. Disassembly will be required to clean any oil or grease build-up.

**! Caution:**

Do not attempt to use a solvent to remove oil or grease without first removing the element. While squirting a solvent into an installed clutch may improve performance temporarily, a fire hazard exists from heat generated during slippage.

**! Caution:**

Do not use compressed air to blow dust accumulations out from between the friction shoes. Although the friction shoes do not contain asbestos, the dust created as the friction material wears, along with the dust from the operating environment, may irritate the respiratory system.

- 4.1.2 Partial or complete disassembly is required to inspect the following items:

**! Caution:**

Operation of the clutch on a drum that has been worn, or has been machined, to less than minimum allowable diameter will result in damage to the element components.

- 4.1.2.1 Drum Diameter Wear - Check the O.D. of the drum and compare to the values shown on Table 3. It is important to check the diameter at several locations across the face. Minor heat-checking may be removed by machining the drum O.D.
- 4.1.2.2 Air Actuating Tube - Check that the rubber tube has not been damaged by excessive heat. If any portion of the tube is hard or charred, the entire element must be replaced. Check for any blisters or bubbles, which would indicate ply separation. A tube in this condition also requires replacement of the entire element.

Element Size	Minimum Drum Diameter
26CM475	25.81 inches (656mm)
30CM500	29.81 inches (757mm)
35CM500	34.81 inches (884mm)
40CM550	39.81 inches (1011mm)
48CM650	47.75 inches (1213mm)

NOTE: The number preceding the letters "CM" in the element size column designates the original drum diameter in inches.

Example: 26CM450 = 26" drum dia..

- 4.1.2.3 Friction Shoe Surface - If the linings are glazed, they may be lightly sanded to remove the glazing PROVIDED THEY DO NOT CONTAIN ASBESTOS.

**! Warning:**

Clean the edge of the lining and note the presence of a red stripe, or a blue stripe with a white stripe, along with brass flakes in the friction material. If the above exists, the linings contain asbestos. Using the appropriate precautions for working with asbestos, remove the linings and dispose of the property. DO NOT ATTEMPT TO SAND FRICTION MATERIAL CONTAINING ASBESTOS!

**! Caution:**

When working with any friction material, regardless of whether or not it contains asbestos, always wear approved safety equipment.

- 4.1.2.4 Uneven Friction Lining Wear - Tapered wear across the friction surface typically indicates a worn drum and/or misalignment.
- 4.1.2.5 Contamination of Friction Shoes - Mild oil or grease contamination may be removed with a solvent. Linings which have become saturated must be replaced. also, linings that have been charred from excessive heat must be replaced.





**Caution:**  
When using any solvent, always follow the appropriate safety precautions.

## 4.2 Friction Lining Replacement

NOTE: If any of the the linings have worn to the minimum allowable thickness of .21 inches (5mm), on the 26CM475, and .18 inches (5mm) on all other CM element sizes, they must be replaced as a complete set. For new thicknesses see table 4.

TABLE 4	
Friction Lining Thickness New	
Model	Thickness-inches(mm)
26CM475	.297(7.54)
30CM500 35CM500 40CM550 48CM650	.328(8.33)



**Caution:**  
Use only genuine Airflex replacement parts. Use of other materials may adversely effect performance.

- 4.2.1 Lay the element on a clean, level work surface with the air connection flange facing "up".
- 4.2.2 Remove the shoe pin cotter pins and discard. Withdraw the shoe pins from the element.
- 4.2.3 Remove the friction shoe assemblies from the element.
- 4.2.4 The friction blocks are riveted to the backing plate. Drill the rivets with a 15/64 inches (6mm) drill and tap the rivet body out.
- 4.2.5 Attach a replacement lining block to the backing plate with new drive pin rivets(000130x0071) (see Figure 3). Work from the center of the friction lining out to the ends. The rivets are installed by driving the pin flush with the head. Insure the rivet flares after installed (see Figure 4).

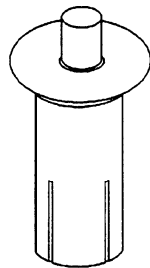

Figure 3



Figure 4

- 4.2.6 Place the new friction shoe assemblies in position. Insert the shoe pins with the heads located on the air connection side of the element.
- 4.2.7 Slide the cotter pins through the holes of the shoe pins making sure that the open ends of the cotter pins face each other. Bend each end of the cotter pins so that equal lengths extend around each side of the shoe pin; otherwise the ends of the cotter pin may puncture the tube. (See Figure 5).

## 5.0 SPARE PARTS STORAGE

### 5.1 Element Assemblies

- 5.1.1 Element assemblies must always be stored flat. Storage in the standing position may cause the rims to go out-of-round.

### 5.2 Drums

- 5.2.1 Drums must be stored in a dry environment. Similar to element assemblies, storage of a drum in the standing position will adversely affect roundness.

## 6.0 ORDERING INFORMATION/ TECHNICAL ASSISTANCE

### 6.1 Equipment Reference

- 6.1.1 In any correspondence regarding Airflex equipment, refer to the information on the product nameplate. If not available, note the drum diameter, mounting arrangement or any other special features and call or write:

Eaton Corporation  
Airflex Division  
9919 Clinton Road  
Cleveland, Ohio 44144  
Ph: 216-281-2211  
FAX: 216-281-3890

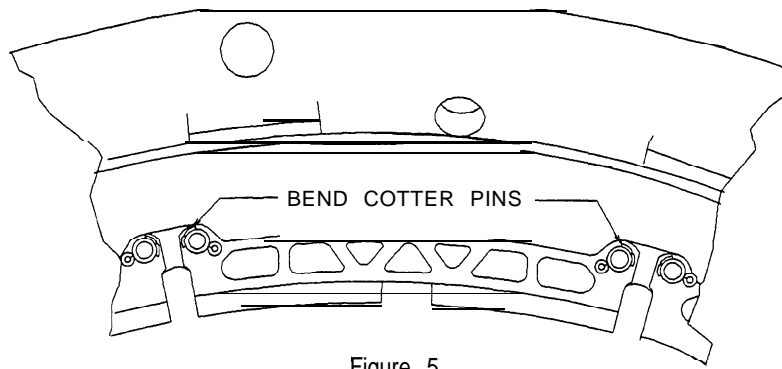
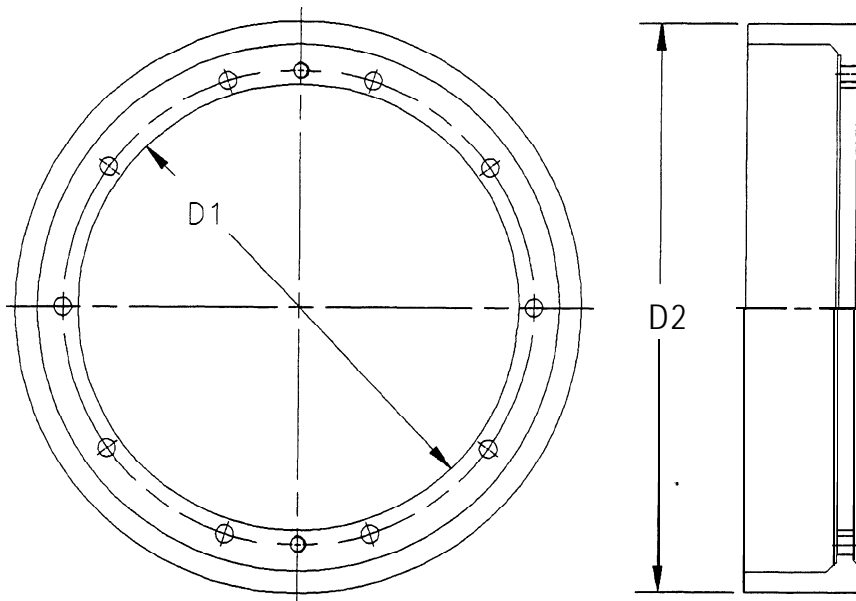

Figure 5

## 7.0 DRUM SELECTION



SIZE	D1 inches(mm)	FORWARD DRIVE DRUMS			REVERSE DRIVE DRUMS		
		Part Number	D2 inches(mm)	Weight lbs(kg)	Part Number	D2 inches(mm)	Weight lbs(kg)
26CM475	26(660)	512239	14.750 (374,7)	190(86)	512240	20.250 (514,4)	145(66)
30CM500	30(762)	512349	18.750 (476,3)	210(95)	512350	24.250 (616,0)	175(79)
35CM500	35(889)	512241	21.875 (555,6)	310(140)	512242	28.375 (720,7)	245(111)
40CM550	40(1016)	512243	24.375 (619,1)	460(990)	512244	31.875 (809,6)	350(159)
48CM650	48(1219)	512245	35.875 (911,2)	590(1070)	512246	40.000 (1016,0)	500(227)

8.0 ELEMENT PARTS LISTS

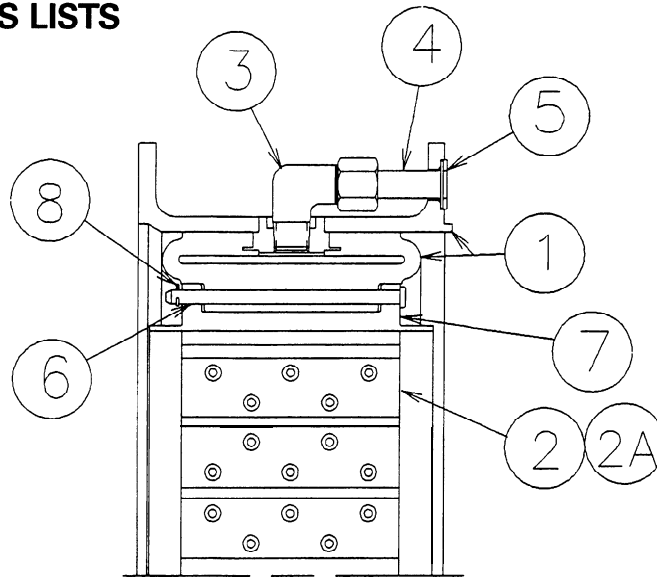

ITEM	ELEMENT SIZE				
	26CM475	30CM500	35CM500	40CM550	48CM650
Complete Element	512047 P/L 146211	512050 P/L 146212	511983 P/L 146207	511990 P/L 146208	512000 P/L 146209
(1) Rim & Tube Assembly	512046 1 each	512049 1 each	511922 1 each	511989 1 each	511999 1 each
(2) Friction Blocks	307498 24 each	307489 28 each	307489 32 each	307490 36 each	307491 42 each
(2A) Rivits	000130x0071 144 each	000130x0071 168 each	000130x0071 192 each*	000130x0071 216 each	000130x0071 294 each
(3) 90 degree Elbow Assembly	000092x0006 1 each	000092x0007 1 each	000092x0008 1 each	000092x0008 1 each	000092x0008 1 each
(4) Air Connection Tube	202169 1 each	202173 1 each	201942 1 each	202699 1 each	202699 1 each
(5) Air Connection Gasket	000072x0054 3 each	000072x0054 3 each	000072x0054 3 each	000072x0056 3 each	000072x0056 3 each
(6) Shoe Pin	202179 24 each	201936 28 each	201936 32 each	202150 36 each	202700 42 each
(7) Friction Shoe Assembly	414791 12 each	307499 14 each	414782 16 each	414783 18 each	414784 21 each
(8) Cotter Pin	000065x0007 24 each	000065x0007 28 each	000065x0007 32 each	000065x0007 36 each	000065x0007 42 each

## **EATON PRODUCT WARRANTY**

Subject to the conditions stated herein, Eaton Corporation warrants to the Purchaser that each new Airflex Product manufactured by Eaton will be free from failures caused by defects in material and workmanship, and will deliver its rated capacity, for a period of twelve (12) months from the date of shipment to Purchaser, provided such Product is properly installed, properly maintained, operated under normal conditions and with competent supervision. Warranty claims shall be made in writing and the part or parts shall, if requested by Airflex Division, be returned prepaid to the Airflex Division for inspection. Upon a determination that a defect exists, Eaton shall thereupon correct any defect, at its option either by repairing any defective part or parts or by making available at Eaton's plant a repaired or replacement part. This warranty does not extend to normal wear parts or components of the Product, such as friction material and friction surfaces.

## **LIMITATION OF WARRANTY**

THE FOREGOING WARRANTY IS EXCLUSIVE AND IN LIEU OF ALL OTHER WARRANTIES WHETHER WRITTEN, ORAL OR IMPLIED. ANY IMPLIED WARRANTY OF MERCHANTABILITY OR FITNESS FOR A PARTICULAR PURPOSE ARE SPECIFICALLY EXCLUDED.

In no event shall Eaton be liable for special, incidental or consequential damages. Eaton's liability arising out of the supplying of such Product, or its use, whether in warranty, contract or otherwise, shall in no case exceed the cost of correcting defects in the Products as herein provided. Upon expiration of the twelve (12) month period, all such liability shall terminate. THE FOREGOING SHALL CONSTITUTE THE SOLE REMEDY OF PURCHASER AND THE SOLE LIABILITY OF EATON.