

Eaton's SPD Series for integration into electrical distribution equipment



Contents

Description	Page
Introduction	2
Applications	2
Features	2
Standards and certifications	2
Feature package options	3
Remote display mounting option	3
Dimensions	3
Performance data	5
Specifications	6
Catalog number selection	7
Technical support information	7



Powering Business Worldwide

Introduction

Eaton's SPD Series surge protective devices

Eaton's SPD Series surge protective devices are the latest and most advanced UL® 1449 4th Edition certified surge protectors. Units are available integrated within Eaton electrical assemblies, including panelboards, switchboards, motor control centers, switchgear, and bus plugs. Side-mount versions of the SPD Series are also available for installation external to an electrical assembly. Application of SPD Series units throughout a facility will ensure that equipment is protected with the safest and most reliable surge protective devices available.

SPD Series units are available in all common voltages and configurations and also in a variety of surge current capacity ratings from 50 through 400 kA. Three feature package options are also available to choose from. The breadth of the SPD Series' features, options, and configurations ensures that the correct unit is available for all electrical applications, including service entrances, distribution switchboards, panelboards, and point-of-use applications.

Applications

The SPD Series is available as an integrated device within the following Eaton electrical assemblies:

- Panelboards
- Switchboards
- Motor control centers
- Switchgear
- Automatic transfer switches
- Bus plugs

Features

- Uses thermally protected metal oxide varistor (MOV) technology
- 20 kA nominal discharge current (I_n) rating (maximum rating assigned by UL)
- 50 through 400 kA surge current capacity ratings
- Three feature package options
- 200 kA short circuit current rating (SCCR)
- Can be used for UL 96A compliance
- Can be used for NFPA compliance
- Can be used for RoHS compliance
- 10-year warranty

Standards and certifications



- UL 1449 4th Edition recognized component for the United States and Canada, covered by Underwriters Laboratories certification and follow-up service

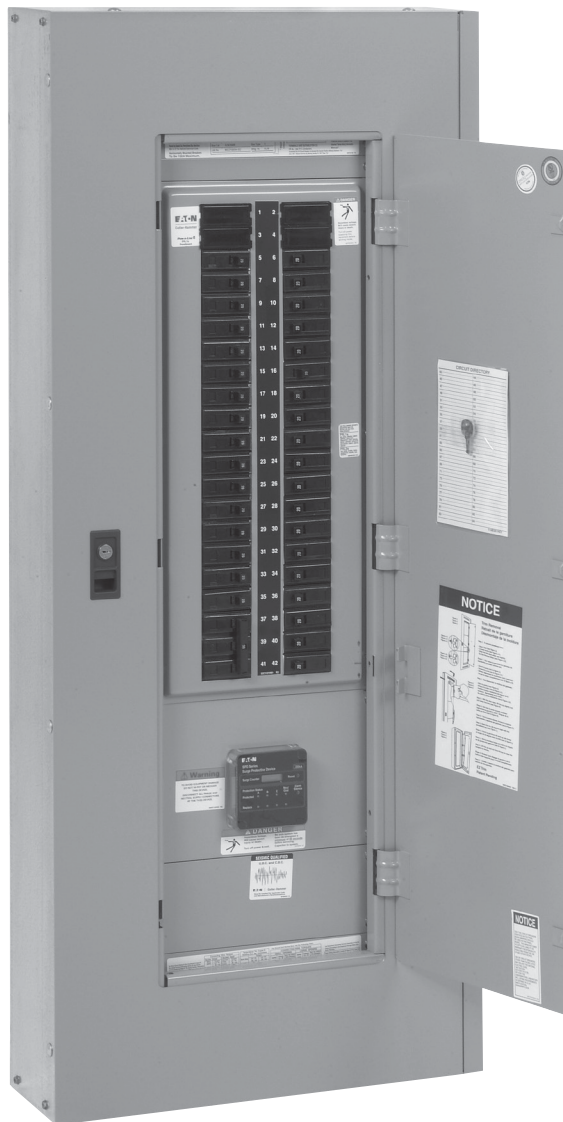

SPD Series unit integrated within an Eaton panelboard

Feature package options

The SPD Series provides users with the option of selecting between three feature packages. These feature packages are the basic, standard, and standard with surge counter. The proper feature package can be selected based on the requirements of the application or specification.

Table 1. Feature package comparison

Feature	Basic	Standard	Standard with surge counter
Surge protection using thermally protected MOV technology	■	■	■
Dual-colored protection status indicators for each phase	■	■	■
Dual-colored protection status indicators for the neutral-ground protection mode	■	■	■
Audible alarm with silence button		■	■
Form C relay contact		■	■
EMI/RFI filtering, providing up to 50 dB of noise attenuation from 10 kHz to 100 MHz		■	■
Surge counter with reset button			■

Remote display mounting option

The SPD Series offers the option of mounting its display remotely from the device. This is useful for applications where OEMs or other integrators would like to embed the unit within a piece of equipment and still be able to view its display.

SPD Series unit catalog numbers ending with 'B' (refer to catalog number configuration on **page 7**) should be ordered for applications where the display is to be mounted remotely. These units include the SPD Series unit and the remote display panel.

In addition to the unit itself, a remote display cable will have to be purchased. Remote display cables are available in 4, 8, and 12 foot lengths.

Table 2. Remote display cables

Description	Catalog number
4 ft remote display cable	SPDRDCAB04
8 ft remote display cable	SPDRDCAB08
12 ft remote display cable	SPDRDCAB12

Note: Integrated units factory-installed with Eaton switchgear assemblies do not require the purchase of a remote display cable. The cable is provided and all required mounting is performed at the factory.

Existing SPD Series units previously installed without a remote display also have the capability of mounting their displays remotely from the device. Complete remote display kits are available that contain all items required to mount the display remotely, including the remote display cable. Remote display kits are available in 4, 8, and 12 foot cable length options.

Table 3. Remote display kits

Description	Catalog Number
Remote display kit with 4 ft remote display cable	SPDRDKIT04
Remote display kit with 8 ft remote display cable	SPDRDKIT08
Remote display kit with 12 ft remote display cable	SPDRDKIT12

For the dimensions of the cutout required to accommodate the remote display panel, see **Figure 1** below.

Dimensions

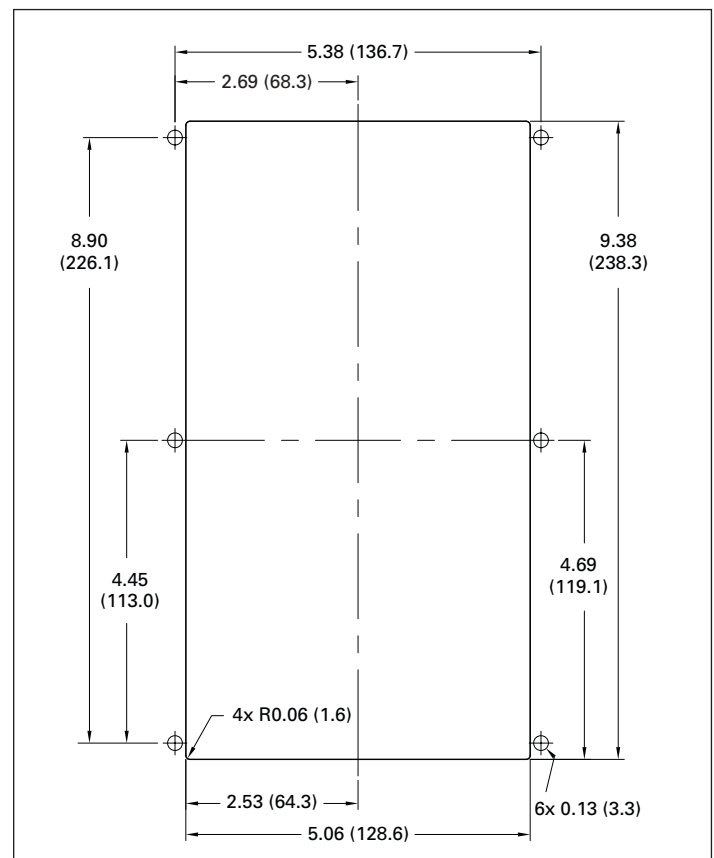

Figure 1. Dimensions of the cutout required to accommodate the optional remote display panel

Dimensions (continued)

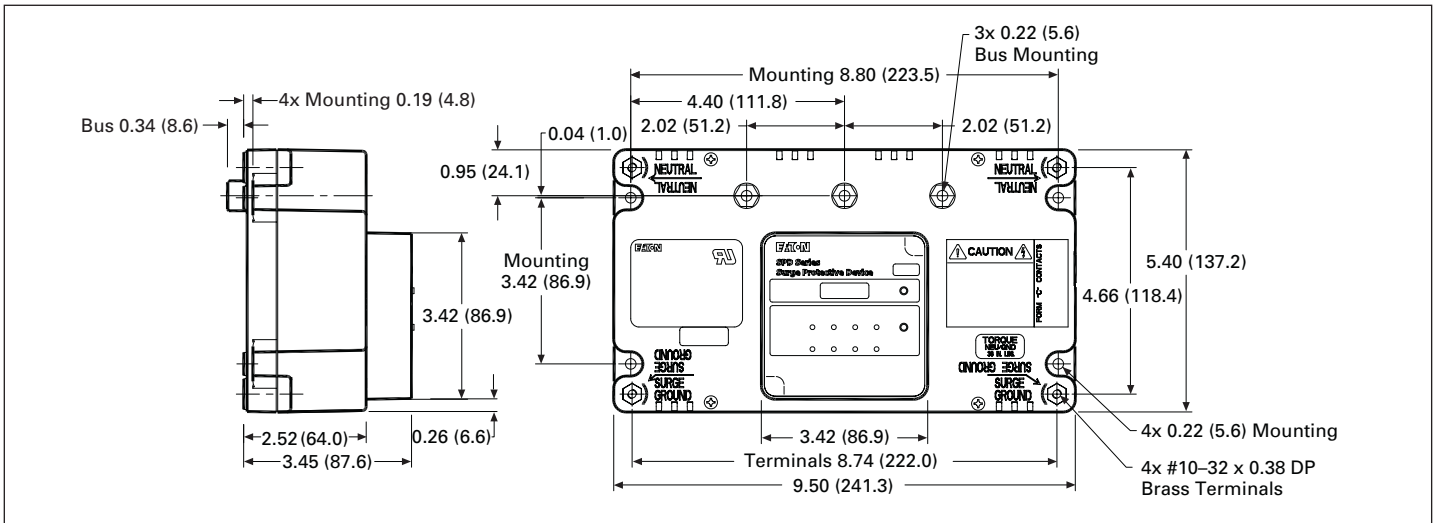

Figure 2. Dimensions of 50 kA through 200 kA integrated units

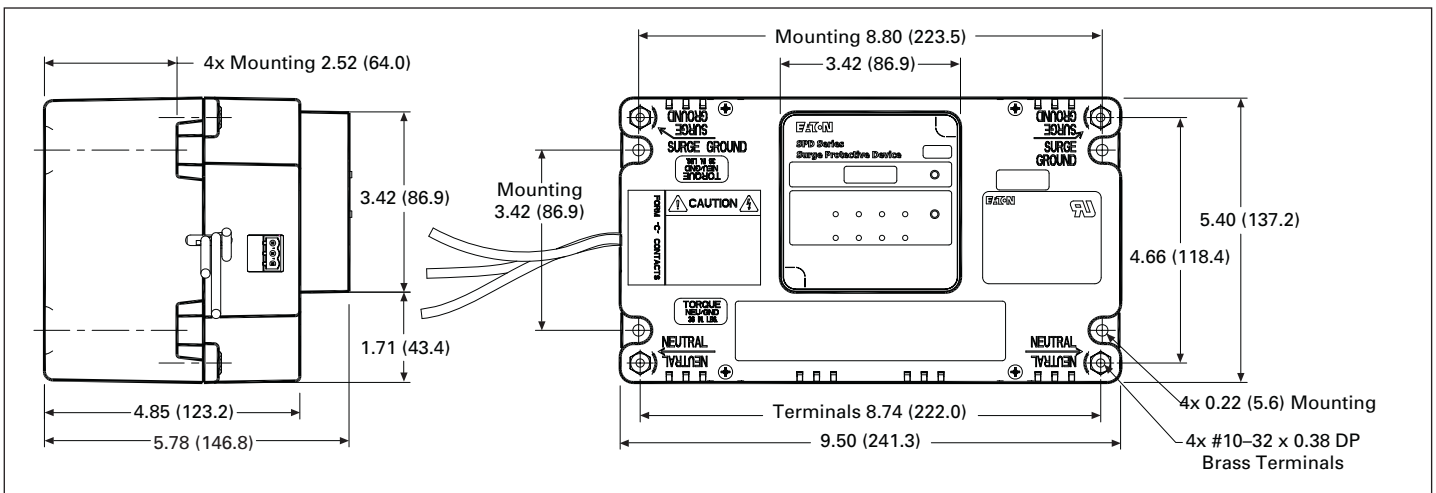

Figure 3. Dimensions of 250 kA through 400 kA integrated units

Performance data

ANSI/UL 1449 4th Edition voltage protection ratings

Voltage protection rating (VPR) data is included for both direct bus mounted units (catalog number ending with 'A') and units interfaced to the electrical assembly via a circuit breaker (catalog number ending with 'B', 'C,' or 'J'). Direct bus mounted units are available for installation within Eaton PRL1a, 2a, 3a, and 3E panelboards only.

Table 4. 50 kA direct bus mounted integrated unit VPR

Voltage code	Protection mode			
	L-N	L-G	N-G	L-L
240S	500	1000	500	1000
208Y and 220Y	500	1000	500	1000
400Y and 480Y	1000	2000	1000	2000
600Y	1200	2500	1200	2500
240D	N/A	1000	N/A	900
480D	N/A	2000	N/A	2000
600D	N/A	2500	N/A	2500
240H	500	1000	500	1000

Table 5. 80–100 kA direct bus mounted integrated unit VPR

Voltage code	Protection mode			
	L-N	L-G	N-G	L-L
240S	500	600	500	900
208Y and 220Y	500	600	500	900
400Y and 480Y	1000	1200	1000	1800
600Y	1200	1500	1200	2500
240D	N/A	1000	N/A	900
480D	N/A	1800	N/A	1800
600D	N/A	2500	N/A	2500
240H	500	600	500	900

Table 6. 120–200 kA direct bus mounted integrated unit VPR

Voltage code	Protection mode			
	L-N	L-G	N-G	L-L
240S	500	600	500	800
208Y and 220Y	500	600	500	800
400Y and 480Y	900	1000	900	1800
600Y	1200	1200	1200	2500
240D	N/A	900	N/A	900
480D	N/A	1800	N/A	1800
600D	N/A	2500	N/A	2500
240H	500	600	500	800

Table 7. 250–300 kA circuit breaker interfaced integrated unit VPR

Voltage code	Protection mode			
	L-N	L-G	N-G	L-L
240S	600Ⓢ	700	600	1000
208Y and 220Y	600Ⓢ	700	600	1000
400Y and 480Y	1000	1200	900	1800
600Y	1500	1500	1200	2500
240D	N/A	1000	N/A	1000
480D	N/A	1800	N/A	1800
600D	N/A	2500	N/A	2500
240H	600Ⓢ	700	600	1000

Ⓢ L-N VPR for 250–300 kA units containing the standard and standard with surge counter feature packages is 600 V. L-N VPR for units containing the basic feature package is 700 V. All other VPR numbers reported in all tables represent the VPR for all feature packages.

Table 8. 50 kA circuit breaker interfaced integrated unit VPR

Voltage code	Protection mode			
	L-N	L-G	N-G	L-L
240S	700	1200	700	1200
208Y and 220Y	700	1200	700	1200
400Y and 480Y	1200	2000	1200	2000
600Y	1500	2500	1500	2500
240D	N/A	1200	N/A	1200
480D	N/A	2000	N/A	2000
600D	N/A	2500	N/A	2500
240H	700	1200	700	1200

Table 9. 80–100 kA circuit breaker interfaced integrated unit VPR

Voltage code	Protection mode			
	L-N	L-G	N-G	L-L
240S	700	700	700	1000
208Y and 220Y	700	700	700	1000
400Y and 480Y	1200	1200	1200	1800
600Y	1500	1500	1500	2500
240D	N/A	1200	N/A	1200
480D	N/A	2000	N/A	2000
600D	N/A	2500	N/A	2500
240H	700	700	700	1000

Table 10. 120–200 kA circuit breaker interfaced integrated unit VPR

Voltage code	Protection mode			
	L-N	L-G	N-G	L-L
240S	700	700	600	1000
208Y and 220Y	700	700	600	1000
400Y and 480Y	1000	1200	1000	1800
600Y	1500	1500	1200	2500
240D	N/A	1000	N/A	1000
480D	N/A	2000	N/A	1800
600D	N/A	2500	N/A	2500
240H	700	700	600	1000

Table 11. 400 kA circuit breaker interfaced integrated unit VPR

Voltage code	Protection mode			
	L-N	L-G	N-G	L-L
240S	700	700	600	1000
208Y and 220Y	700	700	600	1000
400Y and 480Y	1000	1200	900	1800
600Y	1500	1500	1200	2500
240D	N/A	1000	N/A	1000
480D	N/A	1800	N/A	1800
600D	N/A	2500	N/A	2500
240H	700	700	600	1000

Specifications

Table 12. SPD Series specifications

Description	Specification
Surge capacity ratings available	50, 80, 100, 120, 160, 200, 250, 300, 400 kA per phase
Nominal discharge current (I _n)	20 kA
Short circuit current rating (SCCR)	200 kA
SPD type	Basic feature package = Type 1 (can also be used in Type 2 applications) Standard and standard with surge counter feature packages = Type 2
Single split phase voltages available	120/240
Three-phase Wye system voltages available	120/208, 127/220, 230/400, 277/480, 347/600
Three-phase Delta system voltages available	240, 480, 600
Input power frequency	50/60 Hz
Power consumption (basic units): 208Y, 220Y, 240S, 240D, and 240H voltage codes 400Y, 480Y, and 480D voltage codes 600Y and 600D voltage codes	0.5 W 1.1 W 1.3 W
Power consumption (standard and standard with surge counter units): 208Y, 220Y, 240S, 240D, and 240H voltage codes 400Y, 480Y, and 480D basic voltage codes 600Y and 600D voltage codes	0.6 W 1.7 W 2.1 W
Protection modes	Single split phase. L-N, L-G, N-G, L-L Three-phase Wye. L-N, L-G, N-G, L-L Three-phase Delta L-G, L-L Three-phase high-leg Delta . . . L-N, L-G, N-G, L-L
Maximum continuous operating voltage (MCOV): 240S, 208Y, 220Y, and 240H MCOV 400Y and 480Y MCOV 600Y MCOV 240D MCOV 480D MCOV 600D MCOV	150 L-N, 150 L-G, 150 N-G, 300 L-L 320 L-N, 320 L-G, 320 N-G, 640 L-L 420 L-N, 420 L-G, 420 N-G, 840 L-L 320 L-G, 320 L-L 640 L-G, 640 L-L 840 L-G, 840 L-L
Ports	1
Operating temperature	-40 °F to +122 °F (-40 °C to +50 °C)
Operating humidity	5% through 95%, noncondensing
Operating altitude	Up to 16,000 ft (5000 m)
Seismic withstand capability	Meets or exceeds the requirements specified in IBC® 2006, CBC 2007, and UBC® Zone 4
Weight	50–200 kA units approximately 3.5 lbs (1.6 kg) 250–400 kA units approximately 7.0 lbs (3.2 kg)
Form C relay contact ratings	150 Vdc or 125 Vac, 1A maximum
Form C relay contact logic	Power ON, normal state—NO contact = open, NC contact = closed Power OFF or fault state—NO contact = closed, NC contact = open
EMI/RFI filtering attenuation	Up to 50 dB from 10 kHz to 100 MHz
Agency certifications and approvals	UL 1449 4th Edition recognized component for the U.S. and Canada UL 1283 7th Edition (Type 2 SPDs only)
Warranty	10 years

Catalog number selection

Table 13. SPD Series catalog number configuration for units integrated into electrical distribution equipment

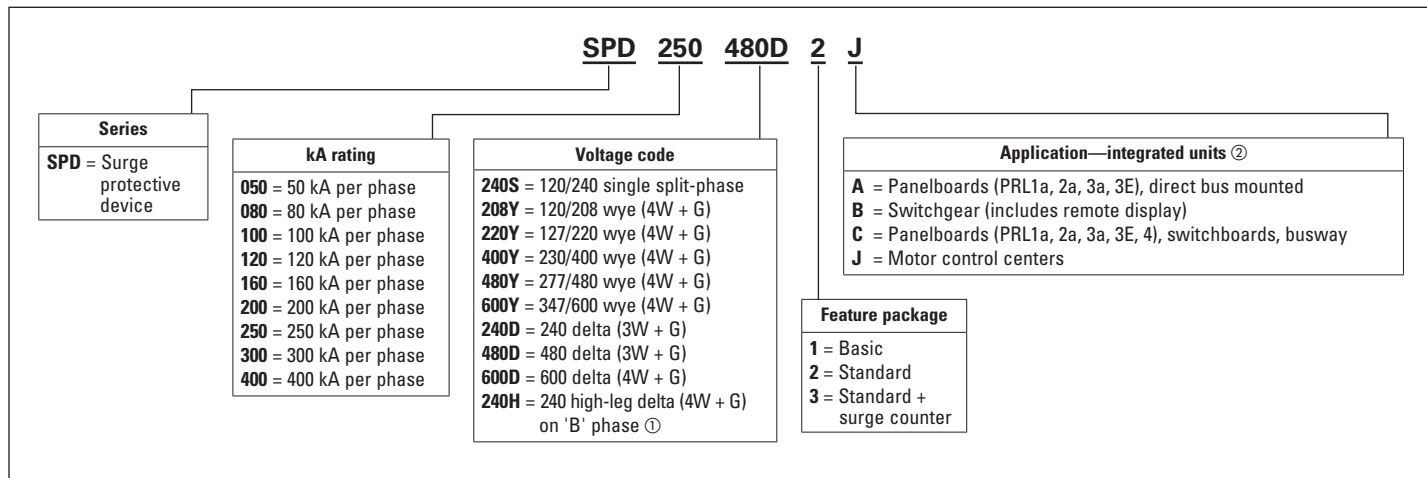

Example: SPD250480D2J = SPD Series, 250 kA per phase, 480D voltage, standard feature package, motor control center application

① Please consult the factory for 240 high-leg Delta (4W+G) applications with high leg on 'C' phase.

② Units used in PRL1a, 2a, 3a, and 3E panelboard applications are available in 50–200 kA ratings only. Use the 'C' option for PRL1a, 2a, 3a, and 3E panelboard applications when unit is connected through a circuit breaker.

If you have any questions or need additional information, please contact the Eaton Technical Resource Center at **1-800-809-2772**, option 4, option 2. You may also submit inquiries via email: surgeprotection@eaton.com

Eaton
1000 Eaton Boulevard
Cleveland, OH 44122
United States
Eaton.com

© 2018 Eaton
All Rights Reserved
Printed in USA
Publication No. TD01005006E / Z21664
November 2018