

# Eaton Innovative Technology XT50/100 surge protective device



## Contents

Description	Page
Introduction . . . . .	2
Installation . . . . .	2
Specifications . . . . .	7
Operation . . . . .	7
Warranty . . . . .	8
Disclaimer of warranties and limitation of liability . . . . .	8



*Powering Business Worldwide*

## Introduction

This manual describes how to install an XT50 or XT100 surge protective device (SPD) in parallel (shunt) across the electrical supply of the following types of electrical systems:

- Single-phase
- Split-phase
- Three-phase wye (star)
- Three-phase delta (no neutral)
- Direct current (DC)

The SPD is designed to be installed on service entrance, branch panels, and/or individual equipment disconnects, and functions to protect sensitive electronic equipment from damaging voltage transients. The connecting wires do not carry supply current. Instead, they carry only short-duration currents that are associated with a transient event.

These instructions do not cover all details, variations, or combinations of the equipment, its storage, delivery, installation, checkout, safe operation, or maintenance. If you require further information regarding a particular application or installation that is not covered in this manual, please contact Eaton’s Power Quality Technical Support at 1-800-647-8877.

## Safety precautions

A licensed/qualified electrician must complete all instructions described in this manual in accordance with the U.S. National Electrical Code®, state and local codes, or other applicable country codes. All electrical codes supersede these instructions.

Table 1. Catalog numbering system

<b>XT 50 - 3Y201</b>		
Per phase peak surge current	Configuration and voltage ranges	# of wires
50 = 50 kA	<b>1P201</b> = Single-phase—200, 208, 220, 230, 240, 277 Vac	2W
100 = 100 kA ①	<b>1P400</b> = Single-phase—480 Vac	2W
	<b>1S101</b> = Split-phase—100/200, 110/220, 120/240, single-phase 120 Vac	3W
	<b>3D101</b> = Three-phase high-leg delta—120/240 Vac	2W
	<b>3Y101</b> = Three-phase wye (star)—100/174, 110/190, 120/208, 127/220 Vac	4W+G
	<b>3Y201</b> = Three-phase wye (star)—220/380, 230/400, 240/415, 277/480 Vac	4W+G
	<b>3Y300</b> = Three-phase wye (star)—305/525, 347/600 Vac	4W+G
	<b>NN201</b> = Three-phase delta—200, 208, 220, 230, 240 Vac	4W+G
	<b>NN400</b> = Three-phase delta—380, 400, 415, 440, 480 Vac	3W+G
	<b>NN501</b> = Three-phase delta—525, 600 Vac (600 Vac available in 50 kA only)	3W+G
	<b>048DC</b> = Direct current—48 Vdc ①	3W+G
	<b>125DC</b> = Direct current—125 Vdc ①	3W+G

① DC models only available in 50 kA.

In this example, catalog number XT50-3Y201 identifies an XT model with the following features and ratings:

- Surge current rating of 50 kA peak per phase
- Three-phase wye wiring configuration
- Voltage range of 220/380 Vac through 277/480 Vac

## Installation

Refer to **Table 2** and look at the label on the SPD to verify that the SPD’s voltage rating and wiring configuration matches that of the electrical system. Use a voltmeter to measure the system’s line voltage to ensure that the correct model of SPD is being installed. Damage to the SPD may result if it is connected to an electrical system of a higher voltage or different wiring configuration.

## Mounting

The SPD can be mounted directly to the electrical panel or mounted to a wall using the enclosure’s internal mounting holes or optional external mounting feet.

<b>NOTICE</b>
<p><b>CHOOSE A MOUNTING LOCATION FOR THE SPD THAT PROVIDES THE SHORTEST AND STRAIGHTEST POSSIBLE WIRING (LEAD LENGTH) FROM THE SPD TO THE ELECTRICAL SYSTEM CONNECTIONS. EXCESSIVE LEAD LENGTH AND SHARP BENDS WILL DEGRADE SPD PERFORMANCE.</b></p>
<p><b>IF THE ELECTRICAL SYSTEM USES AN ISOLATED GROUND, THE SPD MUST BE ISOLATED FROM GROUND USING INSULATED CONDUIT FITTINGS.</b></p>
<p><b>WHEN USING CONDUIT, AVOID USING 90° ELBOWS AND KEEP THE CONDUIT RUN AS SHORT AND STRAIGHT AS POSSIBLE.</b></p>

<b>⚠ WARNING</b>
<p><b>IMPROPER INSTALLATION CAN CAUSE DEATH, INJURY, AND/OR EQUIPMENT DAMAGE. FOLLOW ALL WARNINGS AND CAUTIONS. COMPLETELY READ AND UNDERSTAND THE INFORMATION IN THIS INSTRUCTION MANUAL BEFORE ATTEMPTING TO INSTALL OR OPERATE THIS EQUIPMENT.</b></p>
<p><b>IMPROPER WIRING COULD CAUSE DEATH, INJURY, AND/OR EQUIPMENT DAMAGE. ONLY LICENSED/QUALIFIED ELECTRICIANS WHO ARE TRAINED IN THE INSTALLATION AND SERVICE OF ELECTRICAL DEVICES ARE TO INSTALL THIS EQUIPMENT.</b></p>
<p><b>USE APPROPRIATE SAFETY PRECAUTIONS AND EQUIPMENT FOR ARC FLASH PROTECTION.</b></p>
<p><b>DURING NORMAL OPERATION, HAZARDOUS VOLTAGES ARE PRESENT INSIDE THE SPD.</b></p>
<p><b>WHEN INSTALLING THE SPD, FOLLOW ALL SAFE WORK PRACTICES TO AVOID ELECTRICAL SHOCK.</b></p>

<b>⚠ CAUTION</b>
<p><b>DO NOT PERFORM A HI-POT TEST WITH THE SPD CONNECTED TO THE ELECTRICAL SYSTEM. FAILURE TO DISCONNECT THE SPD DURING A HI-POT TEST WILL RESULT IN DAMAGE TO THE SPD.</b></p>
<p><b>AFTER INSTALLATION, THIS DEVICE IS NOT REPAIRABLE AND CONTAINS NO SERVICEABLE PARTS. IF THE UNIT SHOULD MALFUNCTION OR NEEDS TO BE REPLACED, CONTACT A QUALIFIED ELECTRICIAN OR EATON CARE AT 877-ETN-CARE (877-386-2273).</b></p>

**Conduit installation**

Mount the SPD directly to the electrical panel using a 3/4-inch chase nipple as shown in **Figure 1**.

When mounting the SPD outdoors, use weatherproof conduit and fittings to maintain the enclosure's NEMA® 4X rating. See **Figure 2**.

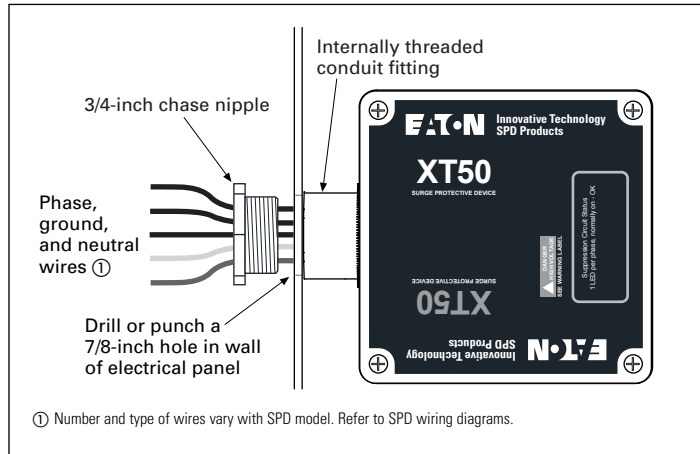

**Figure 1. 3/4-inch chase nipple mounting**

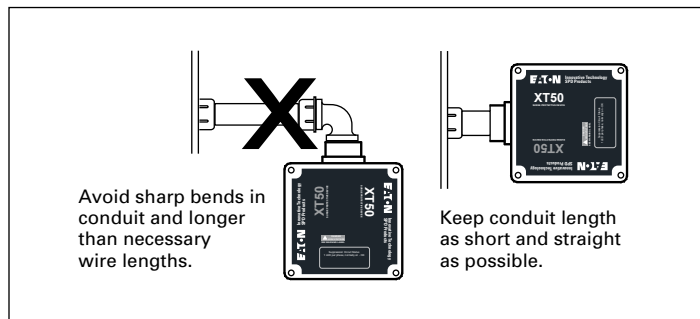
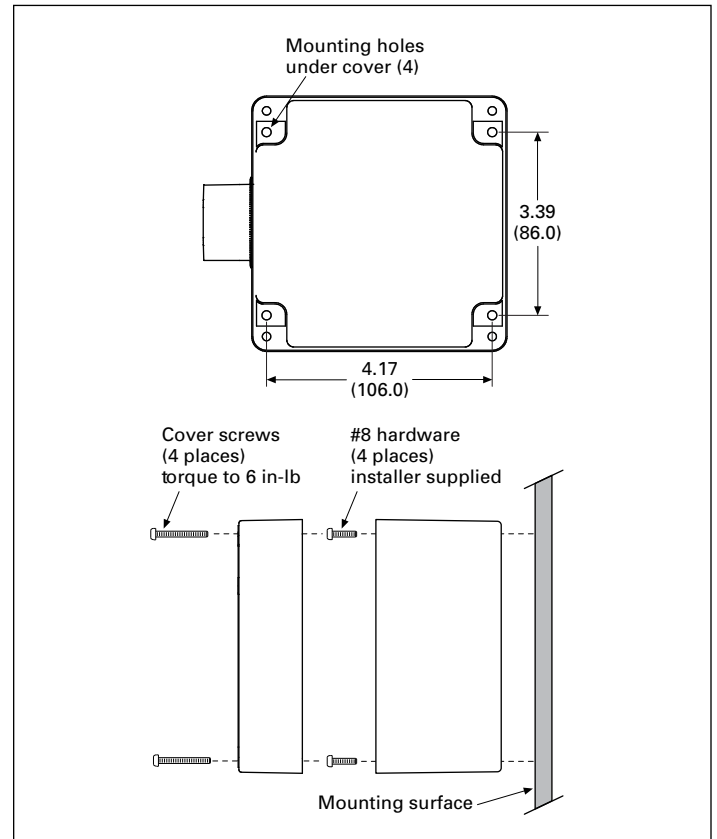

**Figure 2. Conduit installation**

**Wall mounting**

Mount the SPD directly on a wall using the SPD's internal mounting holes as follows:

1. Gain access to the internal mounting holes by first removing the SPD's four front cover screws, and then removing the front cover. See **Figure 3**.
2. Place the SPD against the wall and mark the locations of the four mounting holes.
3. Attach the SPD to the wall using #8 hardware.
4. Reinstall the front cover.



**Figure 3. Wall mounting using internal mounting holes**

### External mounting feet (optional)

Optional external mounting feet with screws (catalog number MNTGFTX) can be used to mount the SPD to a wall without removing the front cover as shown in **Figure 4**.

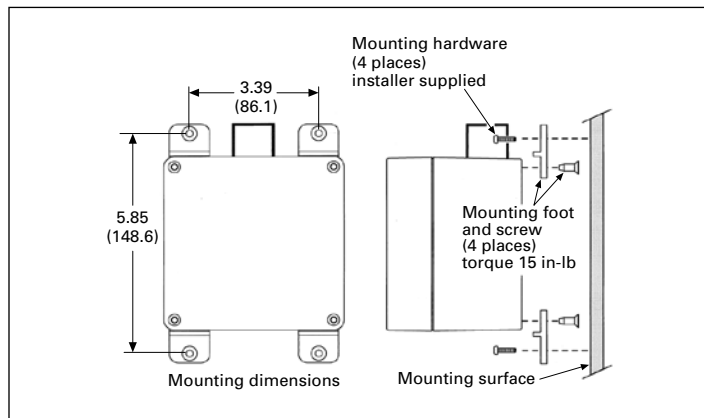

**Figure 4. Wall mounting using external mounting feet**

### Flush mount plate (optional)

Optional flush mounting plate (catalog number FLUSHMNTPLATE12-IT) can be used when mounting the SPD flush with a wall.

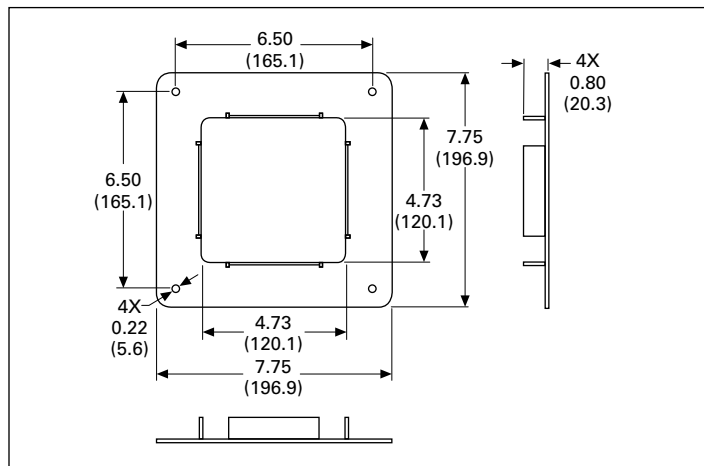

**Figure 5. Optional flush mount plate**

### Wiring for AC units

<b>NOTICE</b>
<p><b>BE SURE TO FOLLOW ALL NATIONAL, STATE, AND LOCAL ELECTRICAL CODES WHEN MAKING WIRING CONNECTIONS.</b></p> <p><b>WHEN CONNECTING THE WIRES FROM THE SPD TO THE ELECTRICAL SYSTEM, CUT THE WIRES AS NECESSARY TO KEEP THEM AS SHORT AS POSSIBLE.</b></p> <p><b>TO MAXIMIZE THE SPD'S PERFORMANCE, TWIST AND BIND THE WIRES TOGETHER TO REDUCE THE IMPEDANCE OF THE WIRE (ONE TWIST/ INCH).</b></p> <p><b>IF THE SYSTEM UTILIZES AN ISOLATED GROUND, THE SPD'S GROUND WIRE MUST BE CONNECTED TO THE SYSTEM'S ISOLATED GROUND BUS.</b></p>

1. Locate the electrical system's applicable wiring diagram in **Figure 6** through **Figure 11**. Reference this wiring diagram as necessary in Steps 2, 3, and 4.
2. Connect the SPD's ground wire (green) to the system's ground connection.
3. Connect the SPD's neutral wire (white) to the system's neutral connection (not required for three-phase delta systems—NN201, NN400, NN501).
4. Connect the SPD's phase A, B, and C wires (black) to the system's corresponding phase A, B, and C connections according to applicable national, state, and local electrical codes.

SPD wiring diagrams

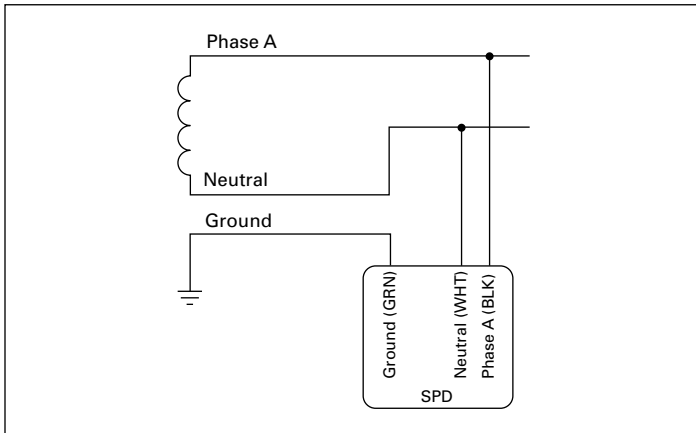

Figure 6. Single-phase (1P201, 1P400)

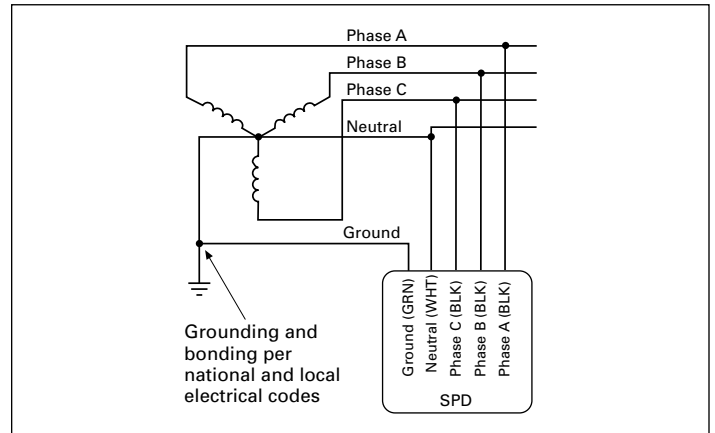

Figure 9. Three-phase wye (star) (3Y101, 3Y201, 3Y300)

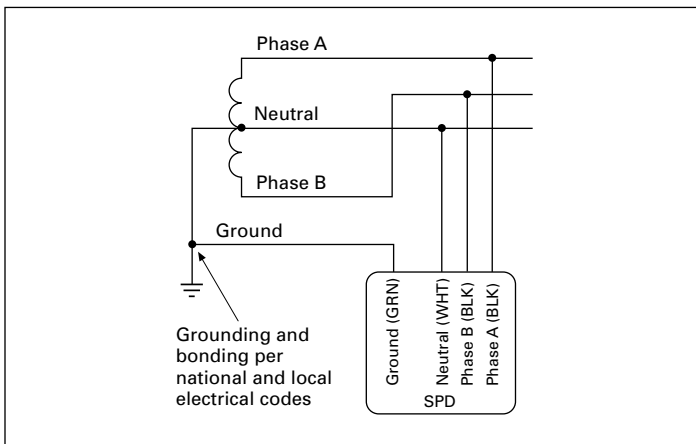

Figure 7. Split-phase (1S101)

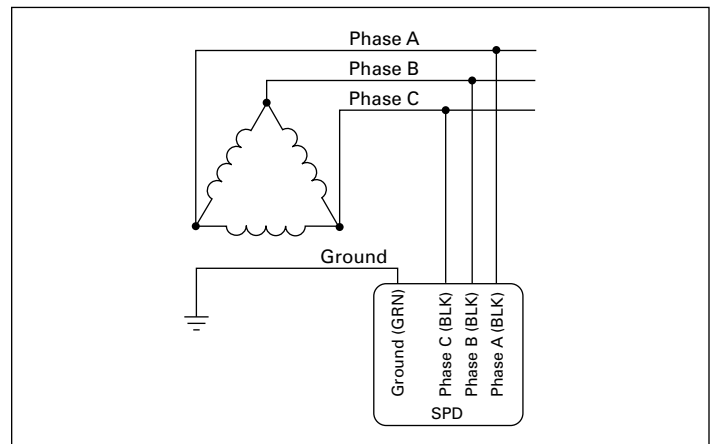

Figure 10. Three-phase delta (no neutral) (NN201, NN400, NN501)

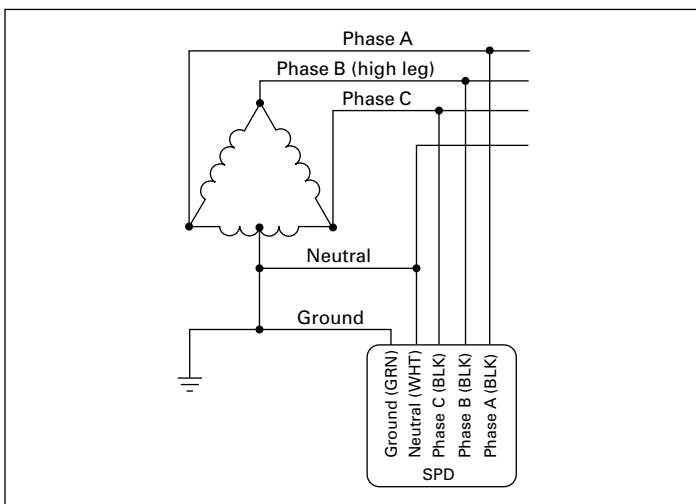

Figure 8. High leg (3D101)

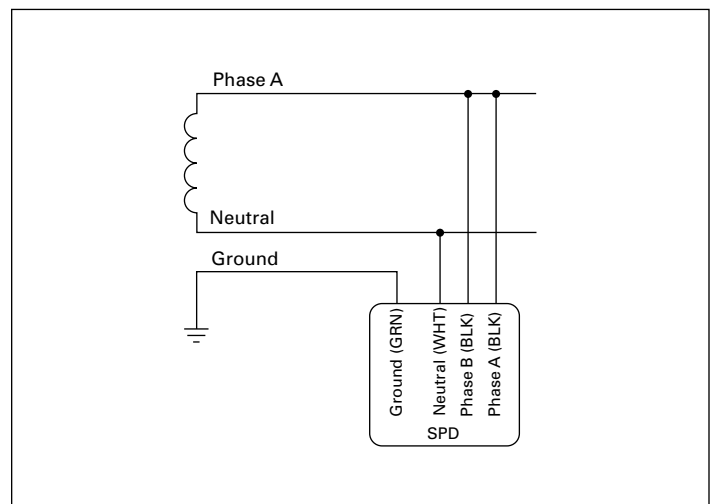

Figure 11. Single-phase 120 V (1S101)

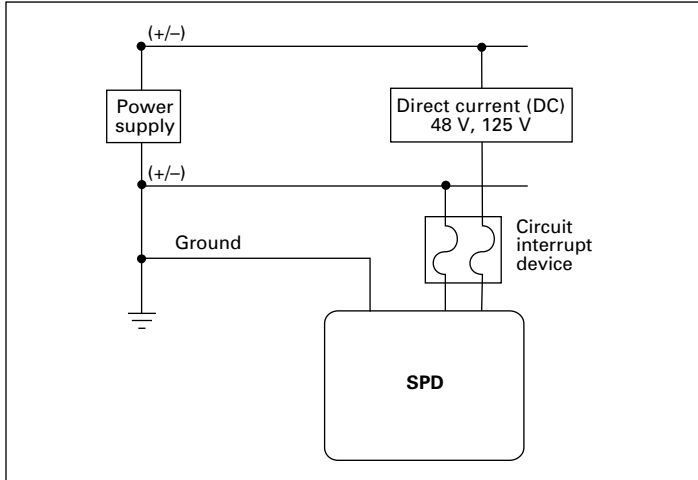

Figure 12. Before installation as SPD

*Before installation as SPD*

**Step A**

Verify system voltage does not exceed maximum suggested operating voltage listed in **Table 2**.

- All voltage measurements should be completed with a DC voltmeter
- **Do not install suppressor if measured voltage exceeds maximum suggested operating limits**

Table 2. Maximum suggested operating voltages and wire colors

Model number	Line-to-line	Line-to-ground	(+/-) Wire color	Ground wire color
XT50-048DC	130	65	Black	Green
XT50-125DC	288	144	Black	Green

**Step B**

Choose suppressor installation location so leads are kept as short and straight as possible. **Suppressor must be connected to electrical system via one of the following circuit interrupt devices:**

- One two-pole/single-throw 30 A circuit breaker
- Note:** Pre-existing breakers of rated load size may be utilized if provisions for multi-conductor connections are made according to NEC® 110.14A.
- Two single-pole/single-throw 30 A circuit breakers
  - Two 30 A Class RK5 fuse(s) (such as Bussmann™ FRN-R-30 for less than 125 Vdc)

**Note:** For isolated ground, suppressor GROUND wire is bonded to shell internally. If system utilizes isolated ground, then suppressor shell must be isolated from ground via insulated conduit fitting and ground wire must be connected to isolated ground bus.

*Before installation as secondary surge arrester*

**Step A**

Verify system voltage does not exceed maximum suggested operating voltage listed in **Table 2**.

- All voltage measurements should be completed with a DC voltmeter
- **Do not install suppressor if measured voltage exceeds maximum suggested operating limits**

**Step B**

No circuit interrupt device is required.

*Installation instructions as SPD*

**Step 1**

Remove power from electrical system before installing suppressor.

**Step 2**

Mechanically mount suppressor:

- Suppressor to be installed through panel knockout and via suppressor optional mounting feet (these are not on this unit). Place suppressor against mounting surface and mark feet positions if applicable. Complete conduit connection installation. Screw box to surface with appropriate screws
- Ensure weatherproof conduit and fittings are used to maintain NEMA 4 rating
- Suppressor to be mounted for shortest and straightest possible wire installation from suppressor to system bus. Excessive wire length and sharp bends degrade suppressor performance; therefore, avoid excessive wire length and sharp bends when at all possible
- If installing on a system other than electrical panel, mount in close proximity to system being protected using necessary means for mounting

**Note:** A circuit interrupt device is still required when installing suppressor on a system other than electrical panel.

- Suppressor contains no position-oriented components and can be mounted upside down or sideways (cover may be rotated only 180 degrees to improve label readability; take care to support cover to prevent damage to indicator light circuit board and wiring)

**⚠ WARNING**

**COVER WILL NOT SEAL WHEN ROTATED ONLY 90 DEGREES. THIS INVALIDATES NEMA 4 RATING AND MAY CREATE SAFETY HAZARD.**

### Step 3

Wire suppressor into electrical system:

- Cut wire(s) as short as possible for optimum suppressor performance
- Connect GROUND (green) wire to system ground busbar. Refer to NOTE for systems utilizing isolated ground
- Connect black wire(s) to “+” and “-” (no polarity required)

### Step 4

Apply power to system. Indicator light should glow. If light does not glow, remove power and contact supplier.

### Installation instructions as secondary surge arrester

#### Step 1

Follow Steps 1 through 4 above, only circuit interrupt device not required.

## Specifications

Description	Specification
Peak kA per phase	XT50 = 50 kA; XT100 = 100 kA ①
Peak kA per mode	50
Nominal discharge current	20 kA (480L, 600D, 600Y = 10 kA)
Single-phase voltages	200, 208, 220, 230, 240, 277, 480 Vac
Split-phase voltages	100/200, 110/220, 120/240, 120 Vac
Wye system voltages	100/175, 110/190, 120/208, 127/220, 220/380, 230/400, 240/415, 277/480 Vac
Delta system voltages	200, 208, 220, 230, 240, 380, 400, 415, 440, 480, 525, 600 Vac
Direct current (DC) voltages	48 Vdc, 125 Vdc
Input power frequency	47 Hz to 420 Hz (50/60 Hz typical)
Protection modes	Single-phase L-N, N-G, L-G Split-phase L-N, N-G, L-G, L-L Wye L-N, N-G, L-G, L-L Delta L-G, L-L Direct current (DC) ① L-L, L-G
Ports	1
Specific energy	100 kJ/ohm
Operating temperature	-13 to 140 °F (-25 to 60 °C)
Weight	≈ 2.0 lb (1.0 kg)
Wire length and AWG	Factory prewired with 16 inches of 10 AWG wire
Certification/listing	UL® 1449 5th Edition Type 1 and Type 2 SPD
UL 96A Compliant	Yes
NFPA 780 Compliant	Yes
ROHS Compliant	Yes

① DC models only available in 50 kA.

## Operation

### Power up and system checkout

Apply system power. One LED should light for each phase voltage being monitored (see **Figure 13**). Single-phase electrical systems will light only one LED, split-phase systems light two LEDs, while three-phase systems light all three.

If the connected LEDs do not light, remove power, check connections, and test again. If the LEDs still do not light, contact your supplier.

### Routine operation

After system power has been applied, the SPD automatically begins to protect downstream electrical devices from damaging voltage transients and surges.

With all phase voltages present, if an LED turns OFF, the SPD has disconnected itself from that phase of the electrical system because one of its thermally protected MOVs has failed. If a thermally protected MOV fails, power will be maintained to the load; however, the load is now **unprotected**.

The XT50/100 is **not repairable** and contains no user serviceable parts. If the unit fails, as shown by at least one of the LEDs turning OFF, the unit must be replaced. Please contact your distributor as the SPD may be under warranty.

**⚠ WARNING**

**DO NOT USE THE SUPPRESSION CIRCUIT STATUS LEDs AS AN INDICATION OF THE PRESENCE OR ABSENCE OF SYSTEM PHASE VOLTAGES.**

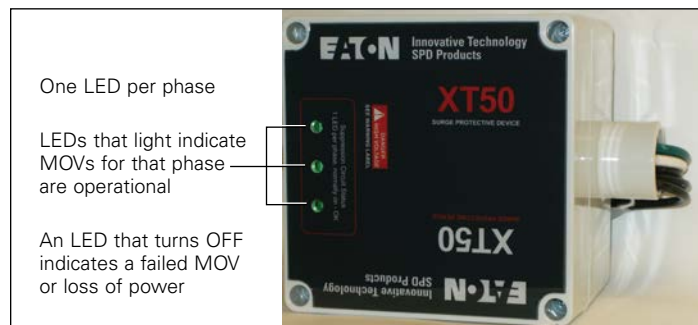

Figure 13. Suppression circuit status LEDs

## Warranty

Eaton warrants these products for a period of 5 years from the date of delivery to the purchaser. To register visit [www.eaton.com/itvss](http://www.eaton.com/itvss) and click the warranty registration icon. Eaton assumes no risk or liability for results of the use of the products purchased from it, including but without limiting the generality of the foregoing: (1) The use in combination with any electrical or electronic components, circuits, systems, assemblies, or any other materials or substances; (2) Unsuitability of any product for use in any circuit or assembly.

Purchaser's rights under the warranty shall consist solely of requiring Eaton to repair, or at Eaton's sole discretion, replace, free of charge, F.O.B. factory, and defective items received at said factory within said term determined by Eaton to be defective. The giving of or failure to give any advice or recommendations by Eaton shall not constitute any warranty by or impose any liability upon Eaton. The foregoing constitutes the sole and exclusive liability of Eaton AND IS IN LIEU OF ANY AND ALL OTHER WARRANTIES EXPRESSED, IMPLIED OR STATUTORY AS TO THE MERCHANTABILITY, FITNESS FOR PURPOSE SOLD, DESCRIPTION, QUALITY, PRODUCTIVENESS OR ANY OTHER MATTER.

In no event shall Eaton be liable for special or consequential damages or for delay in performance of the warranty.

This warranty does not apply if the product has been misused, abused, altered, tampered with, or used in applications other than specified on the nameplate. At the end of the warranty period, Eaton shall be under no further warranty obligation expressed or implied.

The product covered by this warranty certificate can only be repaired or replaced by the factory. For help on troubleshooting the SPD, or for warranty information, call 1-800-809-2772, option 5, sub-option 2. Repair or replacement units will be returned collect. If Eaton finds the return to be a manufacturer's defect, the product will be returned prepaid.

Copyright © by Eaton, Moon Township, PA, USA. All rights reserved. No part of this document may be reproduced in any way without the express written approval of Eaton.

Specifications contained herein are subject to change without notice. EATON - CONFIDENTIAL AND PROPRIETARY NOTICE TO PERSONS RECEIVING THIS DOCUMENT AND/OR TECHNICAL INFORMATION IN THIS DOCUMENT, INCLUDING THE DRAWING AND INFORMATION CONTAINED THEREON, IS CONFIDENTIAL AND IS THE EXCLUSIVE PROPERTY OF EATON, AND IS MERELY ON LOAN AND SUBJECT TO RECALL BY EATON AT ANY TIME. BY TAKING POSSESSION OF THIS DOCUMENT, THE RECIPIENT ACKNOWLEDGES AND AGREES THAT THIS DOCUMENT CANNOT BE USED IN ANY MANNER ADVERSE TO THE INTERESTS OF EATON, AND THAT NO PORTION OF THIS DOCUMENT MAY BE COPIED OR OTHERWISE REPRODUCED WITHOUT THE PRIOR WRITTEN CONSENT OF EATON. IN THE CASE OF CONFLICTING CONTRACTUAL PROVISIONS, THIS NOTICE SHALL GOVERN THE STATUS OF THIS DOCUMENT.

## Disclaimer of warranties and limitation of liability

The information, recommendations, descriptions and safety notations in this document are based on Eaton's experience and judgment and may not cover all contingencies. If further information is required, an Eaton sales office should be consulted. Sale of the product shown in this literature is subject to the terms and conditions outlined in appropriate Eaton selling policies or other contractual agreement between Eaton and the purchaser. THERE ARE NO UNDERSTANDINGS, AGREEMENTS, WARRANTIES, EXPRESSED OR IMPLIED, INCLUDING WARRANTIES OF FITNESS FOR A PARTICULAR PURPOSE OR MERCHANTABILITY, OTHER THAN THOSE SPECIFICALLY SET OUT IN ANY EXISTING CONTRACT BETWEEN THE PARTIES. ANY SUCH CONTRACT STATES THE ENTIRE OBLIGATION OF EATON. THE CONTENTS OF THIS DOCUMENT SHALL NOT BECOME PART OF OR MODIFY ANY CONTRACT BETWEEN THE PARTIES.

In no event will Eaton be responsible to the purchaser or user in contract, in tort (including negligence), strict liability or otherwise for any special, indirect, incidental or consequential damage or loss whatsoever, including but not limited to damage or loss of use of equipment, plant or power system, cost of capital, loss of power, additional expenses in the use of existing power facilities, or claims against the purchaser or user by its customers resulting from the use of the information, recommendations and descriptions contained herein.

**Eaton**  
1000 Eaton Boulevard  
Cleveland, OH 44122  
United States  
[Eaton.com](http://Eaton.com)

© 2023 Eaton  
All Rights Reserved  
Printed in USA  
Publication No. IM01005014E / Z27643  
September 2023