

Installation Instructions for Eaton Surge Protective Devices XXCF23015, XXCFXXX30 and XXCF12060



XXCF23015, XXCF12030



XXCF12060

Contents

Description	Page
1.0 Setup	2
1.1 Before Installation	2
1.2 Installation	2
1.2.1 DIN Rail Kits	2
1.3 Wiring	2
1.3.1 Series Wiring Applications	3
1.3.2 Parallel Wiring Applications	3
1.4 Apply Power	3
1.5 Specifications	4
1.6 Warranty	4

⚠ WARNING

HAZARDOUS VOLTAGES PRESENT

IMPROPER INSTALLATION OR MISAPPLICATION OF THESE DEVICES MAY RESULT IN SERIOUS INJURY TO INSTALLER AND/OR DAMAGE TO ELECTRICAL SYSTEM OR RELATED EQUIPMENT. READ AND UNDERSTAND ALL INSTRUCTIONS BEFORE BEGINNING INSTALLATION. PROTECTIVE EYEWEAR SHOULD BE WORN WHENEVER WORKING AROUND HAZARDOUS VOLTAGES.

NOTICE

ALL INSTRUCTIONS AND MEASUREMENTS MUST BE COMPLETED BY A LICENSED/QUALIFIED ELECTRICIAN IN ACCORDANCE WITH THE U.S. NATIONAL ELECTRICAL CODE, STATE AND LOCAL CODES OR OTHER APPLICABLE COUNTRY CODES. THE U.S. NATIONAL ELECTRICAL CODE AND STATE AND LOCAL REQUIREMENTS (OR OTHER APPLICABLE COUNTRY CODES) SUPERSEDE THIS INSTRUCTION.

Catalog Number	Amps	Voltage Range	Mode	VPR	MCOV	In	SCCR	Peak Surge Current Phase
XXCF12030 ³	30	48 - 149 Vdc ¹ 100 -127 Vac	L-N L-G N-G	500 500 500	150 150 150	5kA	10kA	80kA
XXCF12060 ³	60	48 - 149 Vdc ¹ 100 -127 Vac	N-G	500	150			
XXCF23015 ²	15	120 – 300 Vdc ¹ 120 – 230 Vac	L-N L-G N-G	800 800 800	275 275 275	3kA	10kA	120kA
XXCF23030 ²	30	120 - 300 Vdc ¹ 120 - 230 Vac	N-G	800	275			

¹ UL1449 4th Edition does not list SPD products rated less than 100Vac or DC voltages.

² UL1449 4th Edition, UL1283 7th Edition.

1.0 Setup

Verify system voltages do not exceed those listed in Section 1.5, Specifications.

- All AC measurements should be completed with an RMS voltmeter.
- All DC measurements should be completed with a DC voltmeter.
- **DO NOT INSTALL FILTER IF MEASURED VOLTAGE EXCEEDS MAXIMUM OPERATING LIMITS.**

Choose location for filter installation so that maximum separation can be maintained between input leads, output leads and ground leads.

1.1 Before Installation

REMOVE POWER FROM ELECTRICAL SYSTEM BEFORE MOUNTING FILTER.

- Filter MUST be mounted within enclosure to assure personnel safety from exposed terminals.

IMPORTANT:

FILTER SHOULD BE LOCATED SO THAT THE SHORTEST POSSIBLE CONDUCTOR LENGTH MAY BE USED.

- Filter should be mounted to allow maximum separation between input and output wiring.
- Filter contains no position-oriented components and can be mounted upside down or sideways.
- Filter should be placed in electrical circuit so that it is the last device in the circuit before equipment to be protected.

1.2 Installation

FILTER MUST BE CONNECTED TO ELECTRICAL SYSTEM WITH A CIRCUIT BREAKER:

- 1 - Single Pole / Single Throw 15A, 40A, or 100A circuit breaker(s), The Interrupting Rating of the Circuit Breaker Shall Not Be Less Than the Available Fault Current. Circuit Breaker Ratings of 15A, 240V/415V, 10kA Min. AIC Rating for 15 amp devices, 40A, 240V/415V, 10kA Min. AIC Rating for 30 amp devices and Circuit Breaker Ratings of 100A, 480V, 10kA Min. AIC Rating for 60 amp devices.
- **Note:** Pre-existing breaker(s) of the rated load size may be utilized if provisions for multi-conductor connections are made according to N.E.C. 110-14A.
- If Neutral wire is to be utilized as L2/NEU, then circuit breaker should be provided for that phase.

REMOVE POWER FROM ELECTRICAL SYSTEM BEFORE INSTALLING FILTER.

Mechanically mount filter.

- Mount filter using mounting flange holes or optional DIN bracket listed below.
- Filter should be mounted to allow maximum separation between input and output wiring.
- Filter contains no position oriented components and can be mounted upside down or sideways.
- Filter should be placed in electrical circuit so that it is the last device in circuit before equipment to be protected.

1.2.1 DIN Rail Kits

Mounting bracket and foot adaptable to DIN Rail systems DIN EN 50022, DIN EN 50035 and DIN EN 50045 are available through Eaton Order Center and can be ordered separately.

For 15A and 30A devices:

- Eaton Cat# DINRAILKIT-30ACF
- Eaton Innovative Technology Cat# DINRAILKIT-30ITCF

For 60A devices:

- Eaton Cat# DINRAILKIT-60ACF
- Eaton Innovative Technology Cat# DINRAILKIT-60ITCF

1.3 Wiring

NOTICE

AN INSULATED GROUNDING CONDUCTOR THAT IS IDENTICAL IN SIZE AND INSULATION MATERIAL AND THICKNESS TO THE GROUNDED AND UNGROUNDED CIRCUIT SUPPLY CONDUCTORS, EXCEPT THAT IT IS GREEN WITH OR WITHOUT ONE OR MORE YELLOW STRIPES, IS TO BE INSTALLED AS PART OF THE CIRCUIT THAT SUPPLIES THE FILTER. SEE TABLE 250-122 OF THE NATIONAL ELECTRIC CODE (NEC) REGARDING THE APPROPRIATE SIZE OF THE GROUNDING CONDUCTOR.

THE GROUNDING CONDUCTOR IS TO BE GROUNDED TO EARTH AT THE SERVICE EQUIPMENT OR OTHER ACCEPTABLE BUILDING EARTH GROUND SUCH AS THE BUILDING FRAME IN THE CASE OF HIGH-RISE STEEL FRAME STRUCTURE.

ANY ATTACHMENT-PLUG RECEPTACLES IN THE VICINITY OF THE FILTER ARE TO BE GROUNDING TYPE, AND THE GROUNDING CONDUCTORS SERVING THESE RECEPTACLES ARE TO BE CONNECTED TO EARTH GROUND AT THE SERVICE EQUIPMENT OR OTHER ACCEPTABLE BUILDING EARTH GROUND SUCH AS THE BUILDING FRAME IN THE CASE OF HIGH-RISE STEEL FRAME STRUCTURE

PRESSURE TERMINAL OR PRESSURE SPLICING CONNECTORS AND SOLDERING LUGS USED IN THE INSTALLATION OF THE FILTER SHALL BE IDENTIFIED AS BEING SUITABLE FOR THE MATERIAL OF THE CONDUCTORS. CONDUCTORS OF DISSIMILAR METALS SHALL NOT BE INTERMIXED IN A TERMINAL OR SPLICING CONNECTOR WHERE PHYSICAL CONTACT OCCURS BETWEEN DISSIMILAR CONDUCTORS UNLESS THE DEVICE IS IDENTIFIED FOR THE PURPOSE AND CONDITIONS OF USE.

NOTICE

CONDUCTORS SHOULD BE TWISTED TOGETHER TO REDUCE IMPEDANCE FACTOR. EXCESSIVE WIRE LENGTH AND SHARP BENDS DEGRADE FILTER PERFORMANCE; THEREFORE, AVOID EXCESSIVE WIRE LENGTH AND SHARP BENDS.

1.3.1 Series Wiring Applications

- Connect incoming system **GROUND** wire to terminal labeled **GND** on unprotected end (labeled as **LINE**).
- Connect load side **GROUND** wire to terminal labeled **GND** on protected end (labeled as **EQUIP**).

For AC Applications

- Connect incoming system **NEUTRAL** wire to terminal labeled **L2/NEU** on unprotected end (labeled as **LINE**).
- Connect load side **NEUTRAL** wire to terminal labeled as **L2/NEU** on protected end (labeled as **EQUIP**).
- Connect incoming system **HOT** wire to terminal labeled **L1** on unprotected end (labeled as **LINE**).
- Connect load side **HOT** wire to terminal labeled as **L1** on protected end (labeled as **EQUIP**).

For DC Applications

- Connect incoming system **NEGATIVE** wire to terminal labeled **L2/NEU** on unprotected end (labeled as **LINE**).
- Connect load side **NEGATIVE** wire to terminal labeled as **L2/NEU** on protected end (labeled as **EQUIP**).
- Connect incoming system **POSITIVE** wire to terminal labeled **L1** on unprotected end (labeled as **LINE**).
- Connect load side **POSITIVE** wire to terminal labeled as **L1** on protected end (labeled as **EQUIP**).

1.3.2 Parallel Wiring Applications

IMPORTANT:

FILTER SHOULD BE LOCATED SO THAT THE SHORTEST POSSIBLE CONDUCTOR LENGTH MAY BE USED. CONDUCTORS SHOULD BE TWISTED TOGETHER TO REDUCE IMPEDANCE FACTOR. EXCESSIVE WIRE LENGTH AND SHARP BENDS DEGRADE FILTER PERFORMANCE; THEREFORE, AVOID EXCESSIVE WIRE LENGTH AND SHARP BENDS.

- Connect incoming system **GROUND** wire to terminal labeled **GND** on unprotected end (labeled as **LINE**).

For AC Applications

- Connect incoming system **NEUTRAL** wire to terminal labeled **L2/NEU** on unprotected end (labeled as **LINE**).
- Connect incoming system **HOT** wire to terminal labeled **L1** on unprotected end (labeled as **LINE**).

For DC Applications

- Connect incoming system **NEGATIVE** wire to terminal labeled **L2/NEU** on unprotected end (labeled as **LINE**).
- Connect incoming system **POSITIVE** wire to terminal labeled **L1** on unprotected end (labeled as **LINE**).

Note: For ungrounded or isolated control transformer secondary, DO NOT CONNECT Ground terminal on either LINE or EQUIP side.

1.4 Apply Power

Apply power to system. Indicator light(s) should glow and alarm contacts should move to normal state. If the light does not glow, remove power and contact supplier.

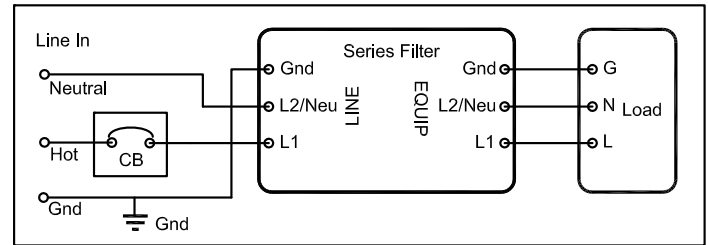

Figure 1. Single Phase Series AC Application

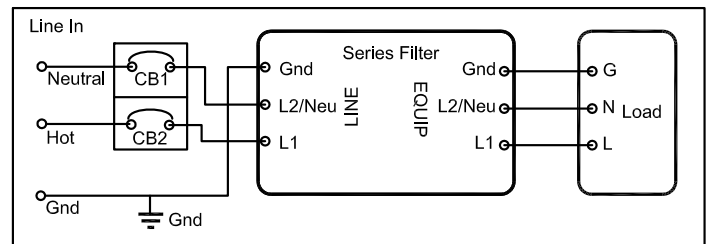

Figure 2. Split Phase Series AC Application (shown with Neutral utilized as L2/NEU)

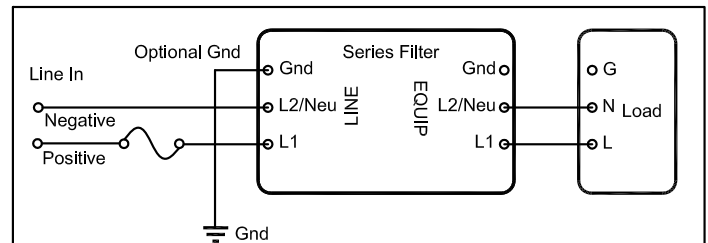

Figure 3. Series DC Application

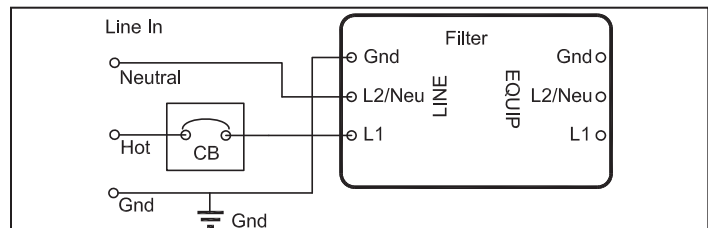

Figure 4. Single Phase Parallel AC Application

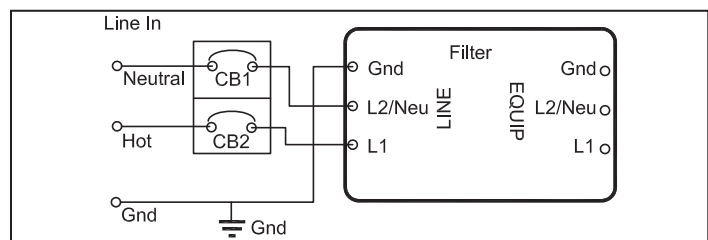

Figure 5. Split Phase Parallel AC Application (Shown with Neutral Utilized as L2NEU)

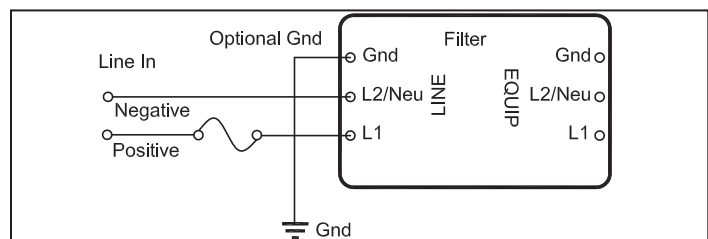

Figure 6. Parallel DC Application

1.5 Specifications

Description	Ratings
Agency Approvals XXCF12030, XXCF12060 XXCF23015, XXCF23030	UL1449 4th edition, UL1283 7th edition
Terminal Connections XXCF23015, XXCFXXX30 XXCF12060	Wire clamping terminals, 10-18 AWG (UL), 10-22 AWG (CSA) Torque 12 in-lb Stud lug terminals Torque 60 lb-in
Operating Temperature	-40F(-40C) to +140F(+60C)
System voltages available DC AC	48 - 149 Vdc, 150 - 300 Vdc, 100 - 127 Vac, 200 - 230 Vac
Amps*	15A, 30A, 60A
Catalog Number XXCF23015 XXCFXXX30 XXCF12060	Circuit Breaker 15A, 240V/415V, 10kA Min. AIC Rating (Eaton P/N:FAZ-C15/1-NA-SP) 40A, 240V/415V, 10kA Min. AIC Rating (Eaton P/N:FAZ-C40/1-NA-SP) 100A, 480V, 10kA Min. AIC Rating (Eaton P/N:EGC3100FFG)
Input Power Frequency	50/60 Hz
Warranty	5 Years, 10 Years if registered on www.eaton.com/spd
RoHS Compliant	Yes

*Amp rating applies to series connection only. For parallel connection Amp ratings are not current dependent.

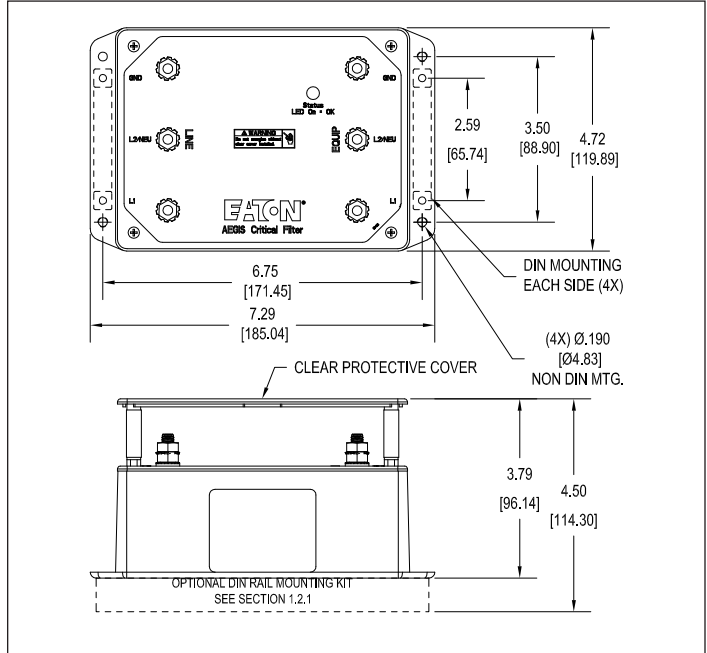

Figure 8. XXCF12060 Product Dimensions

1.6 Warranty

Eaton warrants these products for a period of 5 years from the date of delivery to the purchaser, 10 years if registered on www.eaton.com/spd, to be free from defects in both workmanship and materials. Eaton assumes no risk or liability for results of the use of the products purchased from it, including but without limiting the generality of the foregoing; (1) The use in combination with any electrical or electronic components, circuits, systems, assemblies, or any other materials or substances; (2) Unsuitability of any product for use in any circuit or assembly.

Purchaser's right under the warranty shall consist solely of requiring Eaton to repair, or at Eaton's sole discretion, replace, free of charge, F.O.B. factory, and defective items received at said factory or failure to give any advice or recommendations by Eaton shall not constitute any warranty by or impose any liability upon Eaton. The foregoing constitutes the sole and exclusive liability of Eaton AND IS IN LIEU OF ANY AND ALL OTHER WARRANTIES EXPRESSED, IMPLIED OR STATUTORY AWS TO THE MERCHANTABILITY, FITNESS FOR PURPOSE SOLD, DESCRIPTION, QUALITY, PRODUCTIVENESS OR ANY OTHER MATTER.

In no event shall Eaton be liable for special or consequential damages or for delay in performance of the warranty.

This warranty does not apply if the product has been misused, abused, altered, tampered with, or used in applications other than specified on the nameplate. At the end of the warranty period, Eaton shall be under no further warranty obligation expressed or implied.

The product covered by this warranty certificate can only be repaired or replaced by the factory. For help on troubleshooting the Critical Protection Product, or for warranty information, call 1-800-809-2772, Option 4, sub-option 2. Repair or replacement units will be returned collect. If Eaton finds the return to be a manufacturer's defect, the product will be returned prepaid.

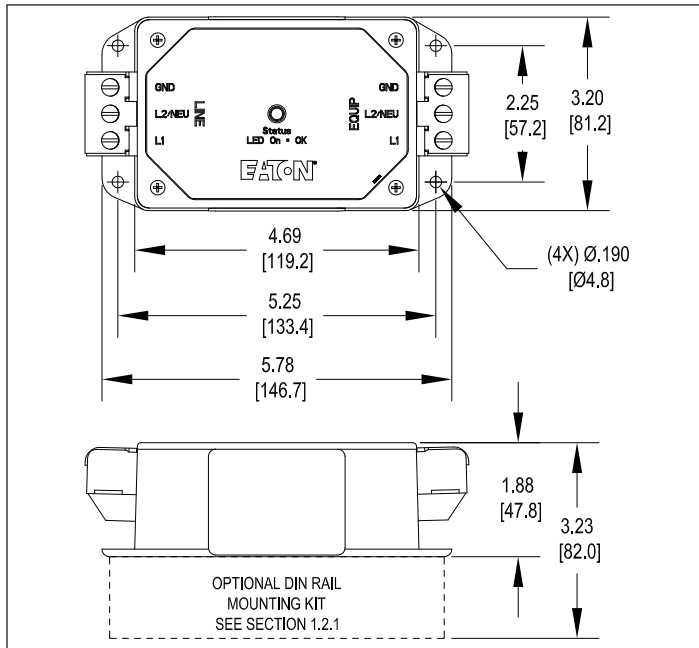

Figure 7. XXCF23015 and XXCFXXX30 Product Dimensions

Eaton
Electrical Sector
1000 Eaton Boulevard
Cleveland, OH 44122
United States
877-ETN-CARE (877-386-2273)
Eaton.com

© 2018 Eaton
All Rights Reserved
Printed in USA
Publication No. IM01005025E / TBG000468
October 2018