

Installation Instructions for Eaton's Aegis Surge Protective Device AGPHxxxxx and AGPVxxxxx



Aegis PH



Aegis PV

Contents

Description	Page
Introduction	2
Safety Precautions.	2
Operation.	2
Preparation	2
Installation Procedures	3
Enclosure Mounting (New Applications - Aegis PH and Aegis PV).	3
Enclosure Mounting (Existing Aegis HW applications).	3
Wiring Instructions Aegis PH.	3
Enclosure Mounting (Existing Aegis VL applications).	5
Wiring Instructions Aegis PV.	5
Specifications	7
Diagnostics	7
Maintenance	7
Terms and Conditions	7
Warranty	8



Powering Business Worldwide

Introduction

Eaton's Aegis PH and PV products are premium Surge Protective Devices (SPDs) with filtering. They are applied to protect sensitive electronic equipment (critical loads) from transients and electrical line noise. Correct installation is critical for the proper operation of the Aegis PH and PV units. Please read the installation and operating instructions prior to installing the Aegis PH or PV.

Safety Precautions

WARNING

IMPROPER INSTALLATION COULD CAUSE DEATH, INJURY AND EQUIPMENT DAMAGE. FOLLOW ALL WARNINGS AND CAUTIONS. COMPLETELY READ AND UNDERSTAND THE INFORMATION IN THIS MANUAL BEFORE ATTEMPTING TO INSTALL OR OPERATE THIS EQUIPMENT.

WARNING

IMPROPER WIRING COULD CAUSE DEATH, INJURY AND/OR EQUIPMENT DAMAGE. ONLY LICENSED/QUALIFIED ELECTRICIANS WHO ARE TRAINED IN THE INSTALLATION AND SERVICE OF ELECTRICAL SERVICES ARE TO INSTALL AND SERVICE THIS EQUIPMENT.

WARNING

HAZARDOUS VOLTAGES ARE PRESENT INSIDE THE SPD DURING NORMAL OPERATION. FOLLOW ALL SAFE PRACTICES TO AVOID ELECTRICAL SHOCK.

Operation

Properly installed, Aegis PH and PV products will protect electronic equipment from surges and electrical line noise. They are installed in series with the load to be protected. Under normal conditions, the Aegis PH and PV will only draw a small capacitive current from the line. When electrical surges or line noise exists, the Aegis PH and PV will remove that portion of the disturbance.

Preparation

Before installation, verify that the amperage and voltage ratings of the Aegis PH or PV match the application. The maximum amperage rating of the Aegis PH and PV are identified on the nameplate located on the side of the enclosure. The maximum amperage of the critical load must be equal to or less than the Aegis PH or PV being installed. If the amperage rating is exceeded, the unit can overheat and fail.

To verify the voltage rating, check the nameplate on the side of the Aegis enclosure. The maximum voltage will be the same from Line to Neutral (L-N), Line to Ground (L-G), and Neutral to Ground (N-G). This makes the Aegis PH and PV suitable for bonded systems that are L, N, G as shown in Figures 1 and 3 or for Unbonded systems that utilize L, L, G as shown in Figures 2 and 4. The amperage and voltage rating is also indicated in the catalog number. The catalog number can also be found on the nameplate.

Review the application to ensure physical space exists for the Aegis product installation. Review and check the grounding system. All grounding and bonding systems must meet NEC, CEC and/or applicable local codes. A poor ground or grounding and bonding violations will seriously affect the ability of the Aegis PH and PV to function as specified.

The Aegis PH and PV input ground and output ground are internally wired together. Loads that require a separate ground must use the output ground from the Aegis PH and PV. Loads that are grounded to the chassis of the equipment do not require the output ground from the Aegis PH and PV to prevent ground loops. The Aegis PH and PV input ground should be connected to the local ground point in all installations.

Overcurrent protection is required to protect the distribution system from an unlikely failure of the Aegis PH and PV or downstream load. Overcurrent protection must be sized according to the downstream load with an additional 1, 1.5, or 2.5 ampere margin for the Aegis PH and PV capacitive current draw as shown in Table 1. The circuit breaker sizes shown in Table 2 are based on safety testing of the Aegis units and represent the maximum allowable sizes.

Table 1. Capacitive Current

Voltage	Frequency	Capacitive Current
120V	50 to 60 Hz	1 amp
120V	400 Hz	2.5 amp
220V	50 to 60 Hz	1.5 amp

This ampere margin is especially important for loads under five (5) amperes. The ampere current draw of the Aegis is capacitive and may increase if there is significant noise on the power line. This will not detract from the output current rating of the Aegis PH and PV as the current rating of the Aegis PH and PV is based on the output current only.

An external circuit breaker in series with the load is required for a permanently connected two-port SPD and shall be suitably rated for branch-circuit protection in accordance with the National Electrical Code, ANSI/NFPA-70 and Canadian Electrical Code (CEC). See Table 2. Circuit Breaker Requirements.

Table 2. Circuit Breaker Requirements

Aegis Model	Circuit Breaker Ratings
Aegis PV	7A, 240V/415V, 10kA Min. AIC Rating
Aegis PH	25A, 240V/415V, 10kA Min. AIC Rating

Installation

⚠ WARNING

INSTALLING AN SPD THAT IS IMPROPERLY RATED FOR THE ELECTRICAL SYSTEM VOLTAGE COULD CREATE A POTENTIALLY HAZARDOUS CONDITION, RESULTING IN INJURY OR EQUIPMENT DAMAGE.

⚠ CAUTION

EATON SPD PRODUCTS MUST BE INSTALLED OR REPLACED BY A QUALIFIED ELECTRICIAN TO AVOID INJURY OR EQUIPMENT DAMAGE.

⚠ WARNING

TURN OFF THE POWER SUPPLY BEFORE WORKING IN ANY ELECTRICAL CABINET OR ON ANY CIRCUIT BREAKER PANEL. FAILURE TO DO SO COULD RESULT IN INJURY OR DEATH FROM ELECTRICAL SHOCK.

NOTICE

A POOR GROUND, OR GROUNDING/BONDING VIOLATIONS, COULD PREVENT THE SPD FROM PERFORMING AS SPECIFIED.

For optimal protection, place the Aegis PH and PV as close as possible to the load being protected. Eaton recommends that the wiring from the Aegis PH and PV output terminals to the input terminals of the electronic equipment be kept as short and straight as possible. This will prevent the wiring from acting as an antenna that picks up high frequency noise from the environment. Wiring length to the input terminals of the Aegis PH and PV is not critical.

- To prevent the risk of electrical shock, TURN OFF and Lock Out all power sources to the electrical circuit where the Aegis PH and PV is to be installed.
- Verify that the power has been disconnected with a portable volt-meter or other measuring device.

Enclosure Mounting (New applications)

Every Aegis PH and PV includes a DIN Rail and two mounting screws (#8 Sheet metal screw) to mount the device. Drill appropriate hole sizes, based on material and thickness, at desired spacing using the DIN Rail slots as a template. After the DIN Rail has been secured, engage the Aegis PH or PV base (Output side, enclosure bottom) of the DIN Clip onto the DIN Rail and compress DIN clip spring by pushing the enclosure towards the Input terminal side of the enclosure bottom until the opposite side of the DIN Clip hook engages the DIN Rail. Then slowly release the spring pressure of the DIN clip securing the Aegis enclosure to the DIN Rail. Proceed to the appropriate Wiring Instructions.

Enclosure Mounting (Existing Aegis HW applications)

Aegis HW devices were mounted either with the use of a DIN Rail or by the enclosure's base feet with two screws. If the device was mounted using the enclosure's base feet, uninstall the Aegis HW and dispose of the old hardware. If the Aegis HW was mounted using the DIN Rail feature, place a screwdriver in the slot on the DIN Clip (Output side at bottom of enclosure), pulling the DIN Clip out to release the enclosure from the DIN Rail. If the previous device was DIN Rail mounted you can reuse the existing DIN Rail to mount the new Aegis PH device. Engage the Aegis PH base (Output side, enclosure bottom) of the DIN Clip to the DIN Rail and compress DIN clip spring by pushing the enclosure towards the Input terminal side of the enclosure until the opposite side of the DIN Clip hook engages. Then slowly release the spring pressure securing the Aegis PH enclosure to the DIN Rail.

Wiring Instructions Aegis PH - Install an overcurrent protection device on the input side of the Aegis PH. Wire from the overcurrent protection device to the input terminal(s) of the Aegis PH. The terminals are marked L, N, and G. Wire gauge should be selected to match the amperage of the overcurrent protection device. Ensure that the proper color wire is used (green or green/yellow – ground, white or light blue – neutral, black and/or red – phase). Tighten all input and output terminal connections to 9 lb-in. Wire from the Aegis PH output terminals to the input terminals of the protected load. Tighten all input and output terminal connections to 9 lb-in. Install terminal block covers by pressing into place on both the input and output terminals. If the Form C contact is used for remote monitoring there will be one – N.O. and one – N.C. contact. The terminal connections are labeled on the top of the enclosure. To activate, connect the Form C output terminals to an alarm, light or building monitoring system. Tighten all Form C terminal connections to 4 lb-in. The relay is rated for a maximum of 250V and 8 amperes. Recheck all connections. Restore power to the electrical circuit. Check that the status indicator (green LED) is illuminated. If using the Form C relay contact, check to see that it is operating as desired.

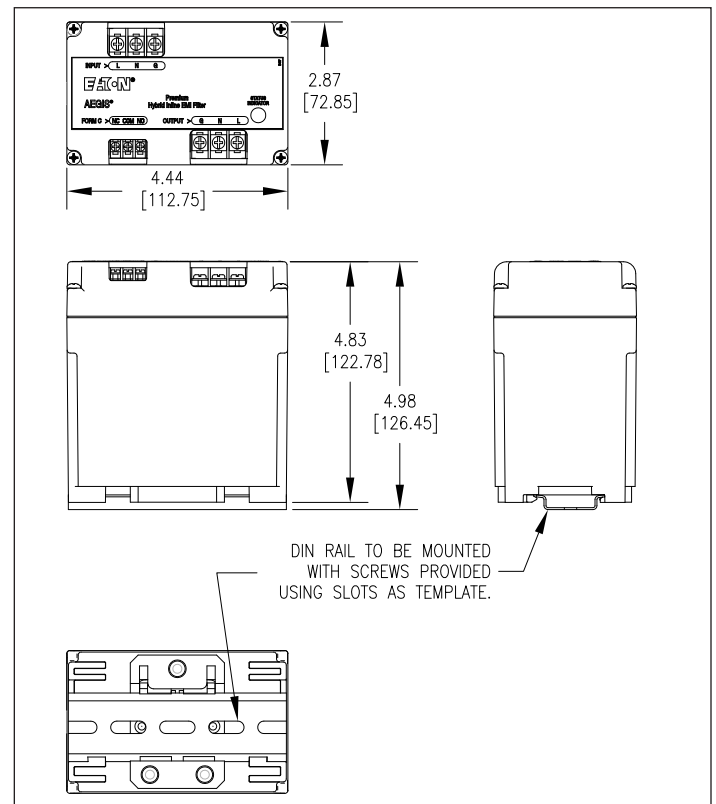

Figure 1. Aegis PH Dimensions.

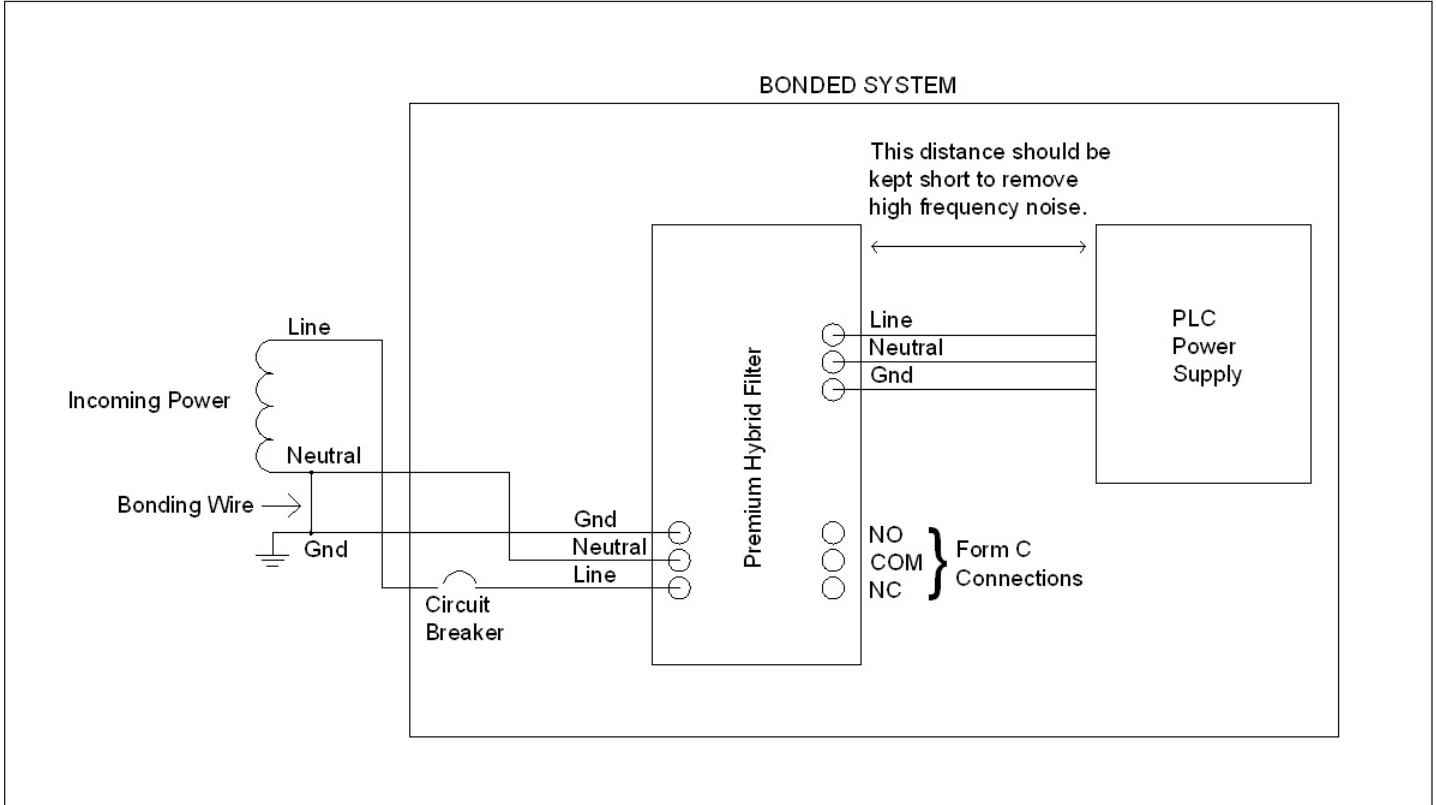

Figure 2. Aegis PH Premium Hybrid Filter Bonded System Block Diagram.

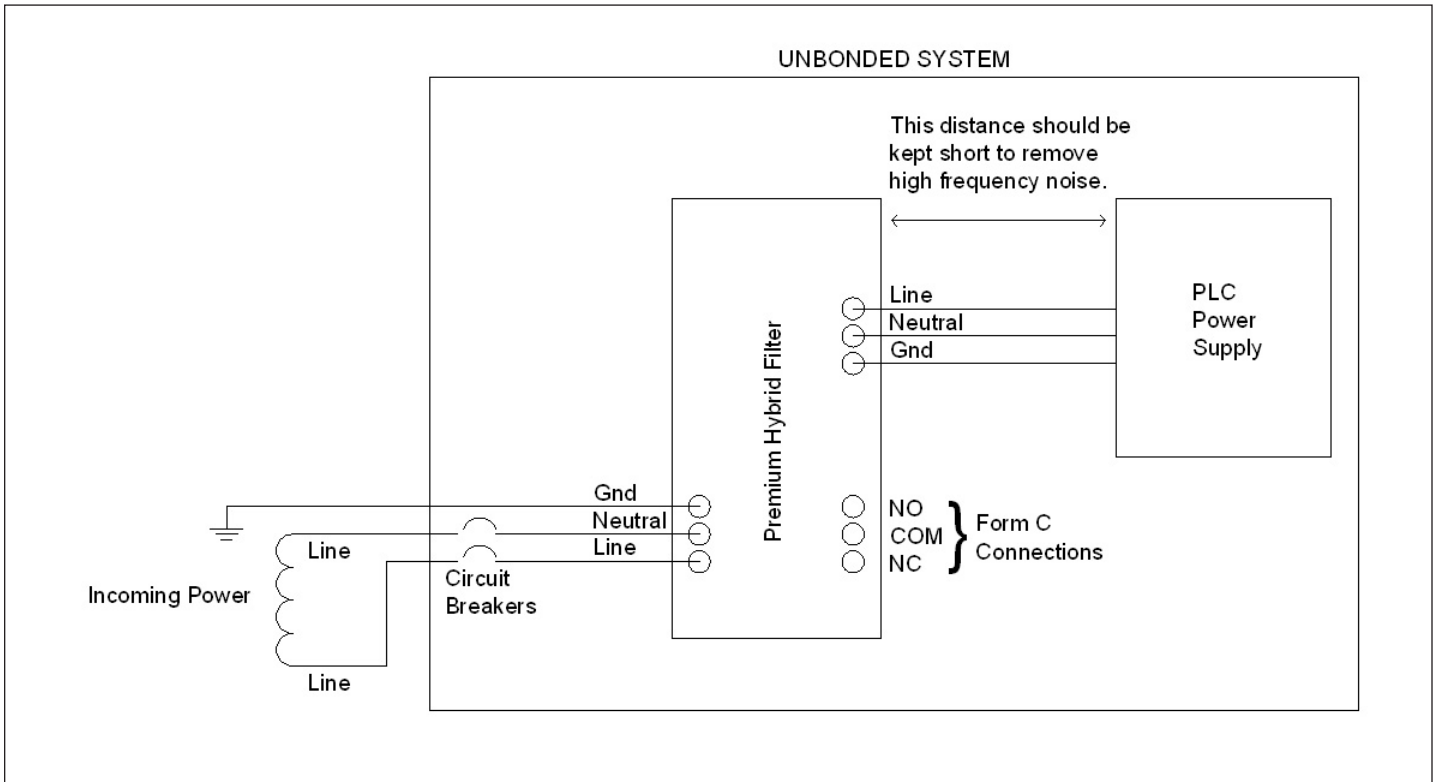

Figure 3. Aegis PH Premium Hybrid Filter Unbonded System Block Diagram.

Enclosure Mounting (Existing Aegis VL applications)

⚠ CAUTION

THE INPUT AND OUTPUT TERMINAL LOCATIONS ARE NOT POSITIONED ON THE SAME SIDE OF THE ENCLOSURE TOP COVER AS THE FORMER AEGIS VL MODELS. ROUTE WIRING TO ACCOMMODATE THE NEW INPUT AND OUTPUT TERMINAL LOCATIONS.

Aegis VL devices mounted to a DIN Rail using the attached DIN clip. Remove the existing device from the DIN Rail by placing a screw driver in slot on the DIN Clip (Output side at base), pulling the DIN Clip out to release the enclosure from the DIN Rail. Now install the Aegis PV device using the attached DIN clip mounted on the bottom of the enclosure. Engage the Aegis PV base (Output side, enclosure bottom) of the DIN Clip to the DIN Rail and compress DIN clip spring by pushing the enclosure towards the Input terminal side of the enclosure until the opposite side of the DIN Clip hook engages. Then slowly release the spring pressure securing the Aegis PV enclosure to the DIN Rail.

Wiring Instructions Aegis PV - Install an overcurrent protection device on the input side of the Aegis PV. Wire the overcurrent protection device to the input terminal(s) of the Aegis PV. The terminals are marked L, N, and G. Wire gauge should be selected to match the amperage of the overcurrent protection device. Ensure that the proper color wire is used (green or green/yellow – ground, white or light blue – neutral, black and/or red – phase). Wire from the Aegis PV output terminals to the input terminals of the protected load. Tighten all input and output terminal connections to 9 lb-in. Install terminal block covers by pressing into place on both the input and output terminals. Recheck all connections. Restore power to the electrical circuit. Check that the status indicator (Green LED) is illuminated.

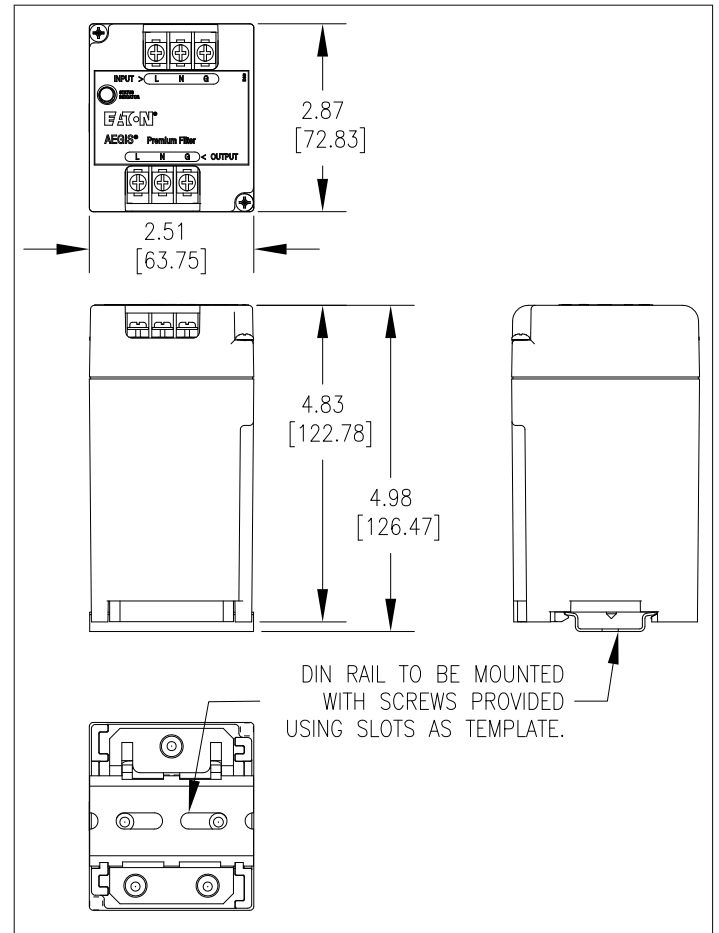

Figure 4. Aegis PV Dimensions.

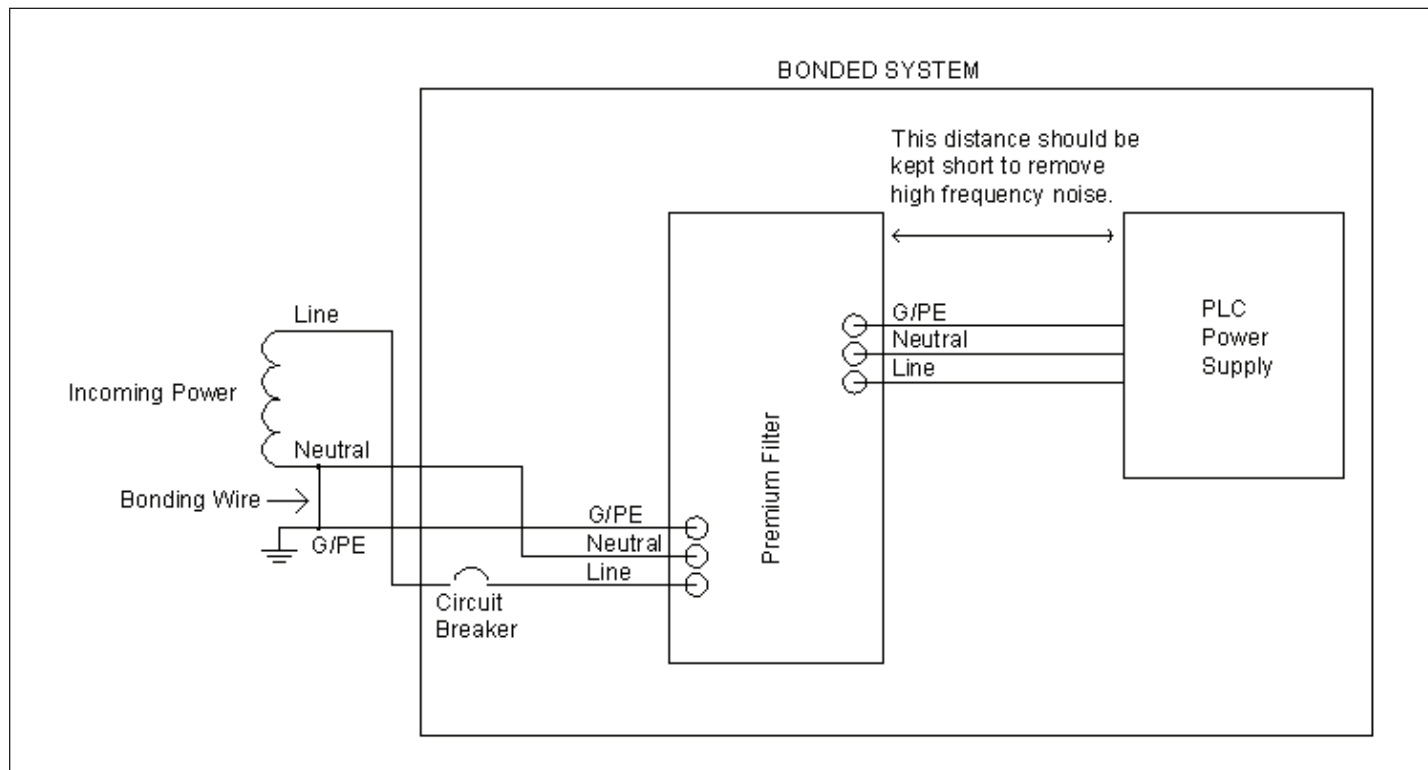

Figure 5. Aegis PV Premium Filter Bonded System Block Diagram.

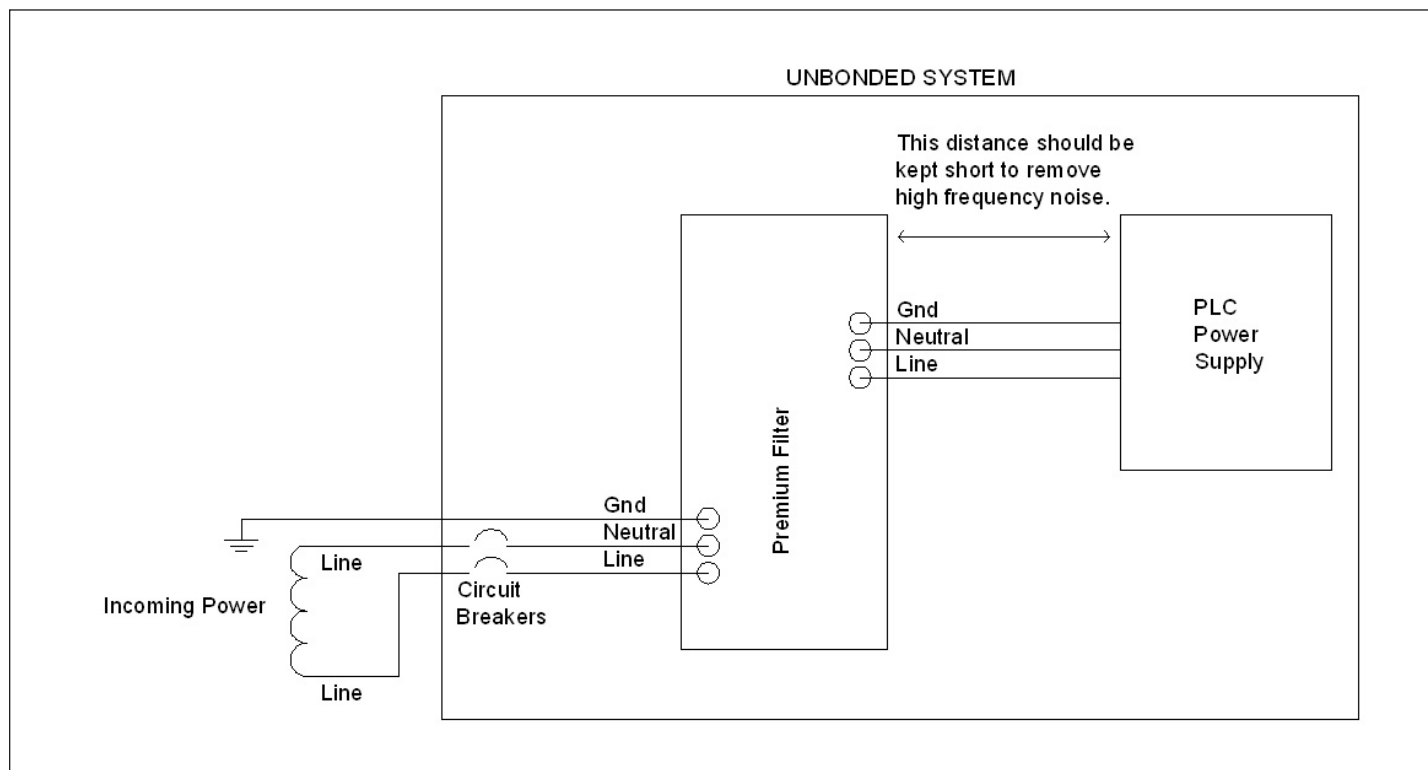

Figure 6. Aegis PV Premium Filter Unbonded System Block Diagram.

Specifications

Table 3. Specifications

Application	Aegis PH 2 W&G Grounded Systems	Aegis PV 2 W&G Grounded Systems
Input Voltage	120V, 220V, 240Vac single-phase	120V, 220V, 240Vac single-phase
Amperage	3, 5, 10, 15, & 20 amperes	1, 3, 5 amperes
Frequency	50/60 Hz	50/60 Hz
Protection Modes	L-N, L-G, & N-G	L-N, L-G, & N-G
MCOV	150V & 275V	150V & 275V
Noise Attenuation (Normal Mode)	75dB @ 110 KHz	50dB @ 100 KHz
Filter Bandwidth	10 kHz to 100 MHz	10 kHz to 100 MHz
Total Peak Surge Current	30kA per mode	20kA per mode
Operating Temperature	-40°F to +122°F (-40°C to +50°C)	-40°F to +122°F (-40°C to +50°C)
Response Time	Less than one nanosecond	Less than one nanosecond
Agency Approvals	UL 1449 3 rd Edition, UL 1283 5 th Edition, CSA	UL 1449 3 rd Edition, UL 1283 5 th Edition , CSA
Warranty	10 years standard / 5 additional years if registered on-line **	10 years standard / 5 additional years if registered on-line **
Form C Contacts	Yes	No
External Circuit Breaker*	25A, 240V/415V, 10kA Min. AIC Rating	7A, 240V/415V, 10kA Min. AIC Rating
RoHS Compliant	Yes	Yes

*External circuit breaker sold separately.

**Register products on-line at www.eaton.com/spd. Then click on “Warranty Registration”.

Diagnostics

The Aegis PH and PV are supplied with a green LED that will illuminate and indicate power at the output terminals. If the green LED is not illuminated, it indicates that power is not being supplied to the Aegis. The LED will not illuminate if there has been a utility power failure, or an internal failure of the Aegis suppression components. If the internal suppression components fail, a short circuit will result. The short circuit will open the overcurrent device on the power supply, removing power to the Aegis. Whenever power is removed from an Aegis PH or PV, the green LED will not illuminate, and the optional monitoring relay (Form C contact), if installed, will change state.

Maintenance

Preventive Maintenance (Inspection and Cleaning) – Periodic system inspections, cleaning, and connection checks are recommended to ensure reliable system performance. There is no defined schedule for preventive maintenance, as conditions will vary from installation to installation.

Corrective Maintenance (Repair or Replacement) – the Aegis PH and PV are designed to provide years of continuous service. However, even the most reliable equipment may fail. In the unlikely case that the LED monitor or remote monitoring (Form C contact) indicates a failure, check the overcurrent protection on the power supply. Replace or reset the overcurrent protection. If a problem still exists, contact Eaton’s Surge Protection application support at: 1-800-809-2772, option 4, option 2.

Terms and Conditions of Sale

The Terms and Conditions of Sale are listed in the Eaton Selling Policy, Publication No. SP03000001E.

Warranty

Eaton warrants these products for a period of 10 years from the date of delivery to the purchaser, 15 years if the product is properly registered with Eaton, to be free from defects in both workmanship and materials. Eaton assumes no risk or liability for results of the use of the products purchased from it, including but without limiting the generality of the foregoing: (1) The use in combination with any electrical or electronic components, circuits, systems, assemblies, or any other materials or substances; (2) Unsuitability of any product for use in any circuit or assembly.

Register products on-line at www.eaton.com/spd. After the page opens click on the "Warranty Registration" link in the right hand column.

Purchaser's rights under the warranty shall consist solely of requiring Eaton to repair, or at Eaton's sole discretion, replace, free of charge, F.O.B. factory, and defective items received at said factory within said term determined by Eaton to be defective. The giving of or failure to give any advice or recommendations by Eaton shall not constitute any warranty by or impose any liability upon Eaton. The foregoing constitutes the sole and exclusive liability of Eaton AND IS IN LIEU OF ANY AND ALL OTHER WARRANTIES EXPRESSED, IMPLIED OR STATUTORY AS TO THE MERCHANTABILITY, FITNESS FOR PURPOSE SOLD, DESCRIPTION, QUALITY, PRODUCTIVENESS OR ANY OTHER MATTER.

In no event shall Eaton be liable for special or consequential damages or for delay in performance of the warranty.

This warranty does not apply if the product has been misused, abused, altered, tampered with, or used in applications other than specified on the nameplate. At the end of the warranty period, Eaton shall be under no further warranty obligation expressed or implied.

The product covered by this warranty certificate can only be repaired or replaced by the factory. For help on troubleshooting the SPD, or for warranty information, call 1-800-809-2772, Option 4, sub-option 2. Repair or replacement units will be returned collect. If Eaton finds the return to be a manufacturer's defect, the product will be returned prepaid.

Eaton
Electrical Sector
1000 Eaton Boulevard
Cleveland, OH 44122
United States
877-ETN-CARE (877-386-2273)
Eaton.com

© 2014 Eaton
All Rights Reserved
Printed in USA
Publication No. IM01005021E / TBG001040
April 2014