

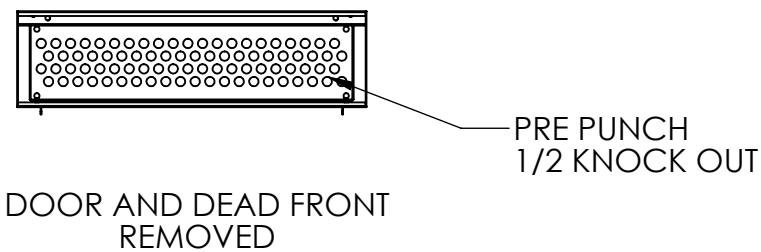

REVISIONS			
REV.	DESCRIPTION	DATE	APPROVED

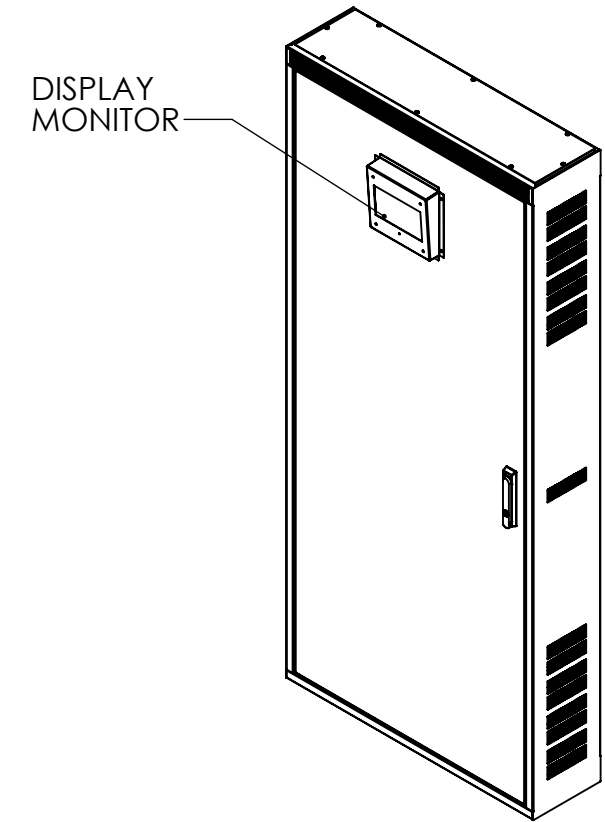
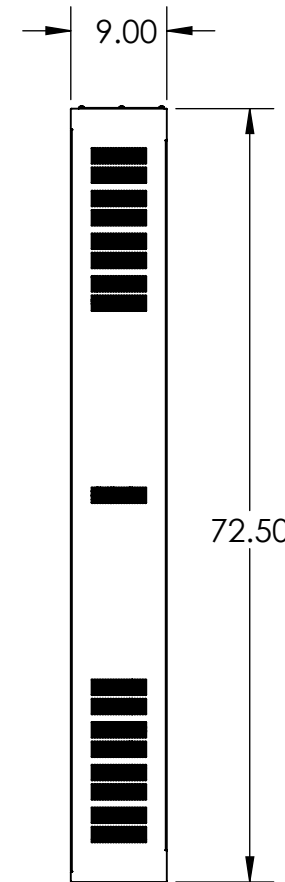
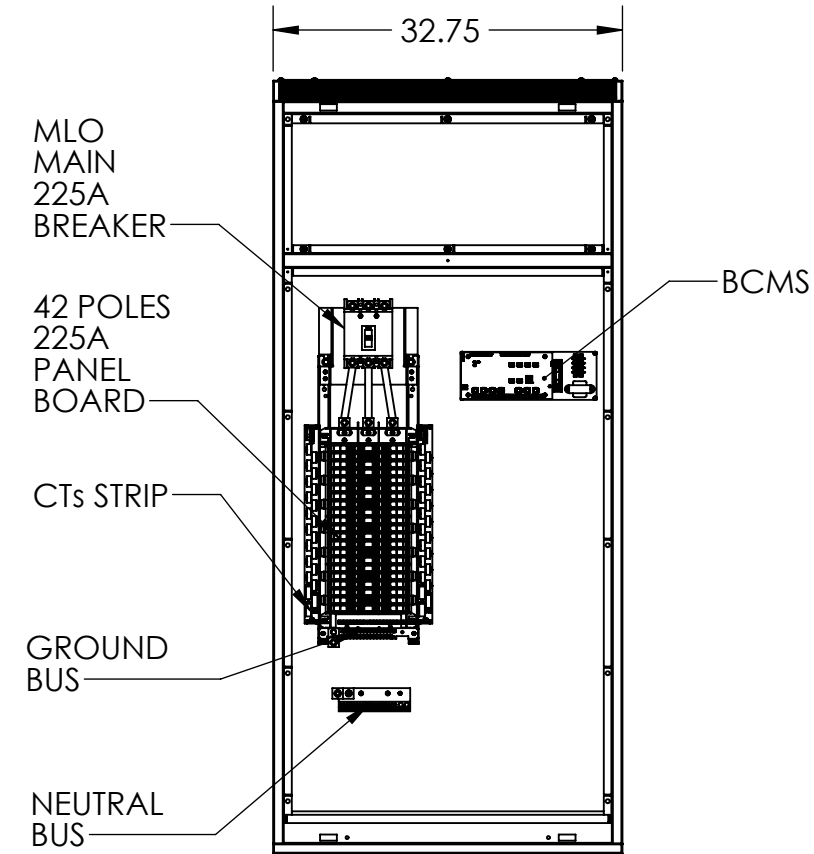
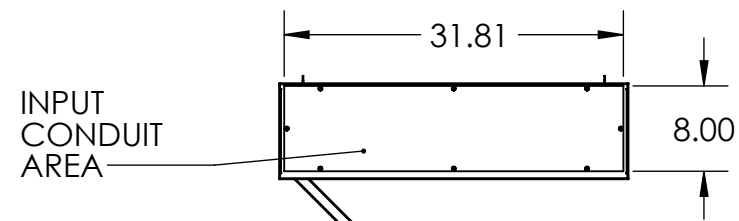
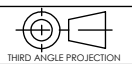

GENERAL SPECIFIED

CABINET CHARACTERISTIC:
ENCLOSURE : NEMA 1
LOCATION : INDOOR
MECHANICAL:
MOUNTING: WALL OR H FRAME
MATERIAL: STEEL
FINISH: EXTERIOR PANELS: PEARL WHITE - PHT1-60016
WEIGHT : 275 LBS.. APPROX.
ELECTRICAL:
INPUT : 208 VAC 3PH-4W W/GND @ 60 HZ, 225A
OUTPUTS PB : 42 POLE, BOLT ON CIRCUIT BREAKER (60 A MAX)

UNLESS OTHERWISE SPECIFIED: DIMENSIONS ARE IN INCHES [] IN MILLIMETER ANGULAR: ±0.5° BEND ±1° TWO PLACE DECIMAL ±0.02 THREE PLACE DECIMAL ±0.005		THIS DRAWING CONTAINS CONFIDENTIAL & PROPRIETARY INFORMATION AND SHALL NOT BE DISCLOSED OR COPIED WITHOUT THE EXPRESSED, WRITTEN PERMISSION OF SMITHS POWER	
 THIRD ANGLE PROJECTION		DO NOT SCALE DRAWING	
APPROVALS		DATE	
DRAWN	LJN	5/5/15	
CHECKED	IF	5/5/15	
ENG. APPR.			

		
TITLE: OUT LINE WALL MOUNT, (1) 225A 42 POLES PANEL BOARD		
SIZE	DWG. NO.	REV
B	RPP18343	X
PART NO.		SHEET 1 OF 1