

# Eaton® Reactor Power Panel V2 (250A)

## Installation and Operation Manual



---

## **IMPORTANT SAFETY INSTRUCTIONS - SAVE THESE INSTRUCTIONS**

---

This manual contains important instructions that you should follow during installation and maintenance of the RPP. Please read all instructions before operating the equipment and save this manual for future reference.

---

---

## **CONSIGNES DE SÉCURITÉ IMPORTANTES – CONSERVER CES INSTRUCTIONS**

---

Ce manuel contient des instructions importantes que vous devez suivre lors de l'installation et de la maintenance de l'équipement. Veuillez consulter entièrement ces instructions avant de faire fonctionner l'équipement et conserver ce manuel afin de pouvoir vous y reporter ultérieurement.

---

---

### **WARNING**

---

This is a product for restricted sales distribution to informed partners (EN/IEC 62040-2). Installation restrictions or additional measures may be needed to prevent electromagnetic disturbances.

---

Eaton reserves the right to change specifications without prior notice. Eaton is a registered trademark of Eaton Corporation or its subsidiaries and affiliates. PDI, JCOMM, Quad-Wye, ToughRail Technology, and WaveStar are registered trademarks of Power Distribution Inc. All other trademarks are property of their respective companies.

©Copyright 2023 Eaton, Raleigh, NC, USA. All rights reserved. No part of this document may be reproduced in any way without the express written approval of Eaton.



Dear Customer,

On behalf of everyone at Eaton, we thank you for partnering with us, for trusting us to maintain your business continuity and for preventing downtime at your facility.

Our suite of backup power, power distribution and power management products are designed to protect you from a host of threats including power outages, surges, and lightning strikes, and enable you to monitor and control your power infrastructure.

We trust that our products will deliver high quality, reliable power for your business, and we are committed to your success.

Please read this manual, which details the installation and operation processes for your new Eaton product.

Thank you for choosing Eaton!



# Table of Contents

<b>1 Introduction</b>	<b>1</b>
1.1 Intended Use	1
1.2 Description	1
1.3 Environmental Information	1
1.3.1 Operating Conditions	1
1.3.2 Storage Conditions	2
1.4 Using This Manual	2
1.5 Conventions Used in This Manual	2
1.6 Symbols, Controls, and Indicators	2
1.7 Getting Help	3
1.8 Warranty and End User License Agreement	3
<b>2 Safety</b>	<b>5</b>
<b>3 Installation</b>	<b>7</b>
3.1 Receiving and Unpacking the RPP	7
3.2 Moving the RPP V2 Unit	7
3.3 Clearances and Door Swing	8
3.4 Anchoring the RPP to the Floor	9
3.5 Cabling	10
3.5.1 Cable Entry	10
3.5.2 RPP V2 One-Line Diagram	12
3.5.3 Relocating Input Bus Bars	13
3.5.4 External Cabling	14
<b>4 Bypass Operation</b>	<b>17</b>
<b>5 Drawings</b>	<b>19</b>
5.1 RPP V2 Left-Hand Configuration Drawings	19
5.2 RPP V2 Right-Hand Configuration Drawings	23
<b>6 Eaton Service Contracts</b>	<b>27</b>
6.1 The Service Promise	27
6.2 Preventive Maintenance	27
6.3 Eaton Provides Flexibility and Commitment	27
6.4 Time and Materials	27
6.5 Startup	27
6.6 Infrared Scanning	27
6.7 Spare Parts Kits	27

Table of Contents

## List of Figures

Figure 1.	RPP V2 (250A) Left Hand Configuration.....	1
Figure 2.	RPP Forklift Positioning .....	8
Figure 3.	RPP Hoist Attachments .....	8
Figure 4.	Door Swing Measurements.....	9
Figure 5.	Floor Anchor Positions .....	10
Figure 6.	RPP Conduit Entry.....	11
Figure 7.	RPP V2 One-Line Diagram.....	12
Figure 8.	Input Bus Bar Positions .....	13
Figure 9.	Input Bus Bar Attachment.....	14
Figure 10.	Cabinet External Connections .....	15
Figure 11.	Input Power Connections.....	16
Figure 12.	Mechanical Transfer Compartment .....	18

List of Figures



# Chapter 1 Introduction

## 1.1 Intended Use

The Reactor Power Panel V2 (RPP V2) (250A) is designed to make maintenance of downstream equipment safer by limiting fault current and reducing the risk of arc flash in downstream equipment.

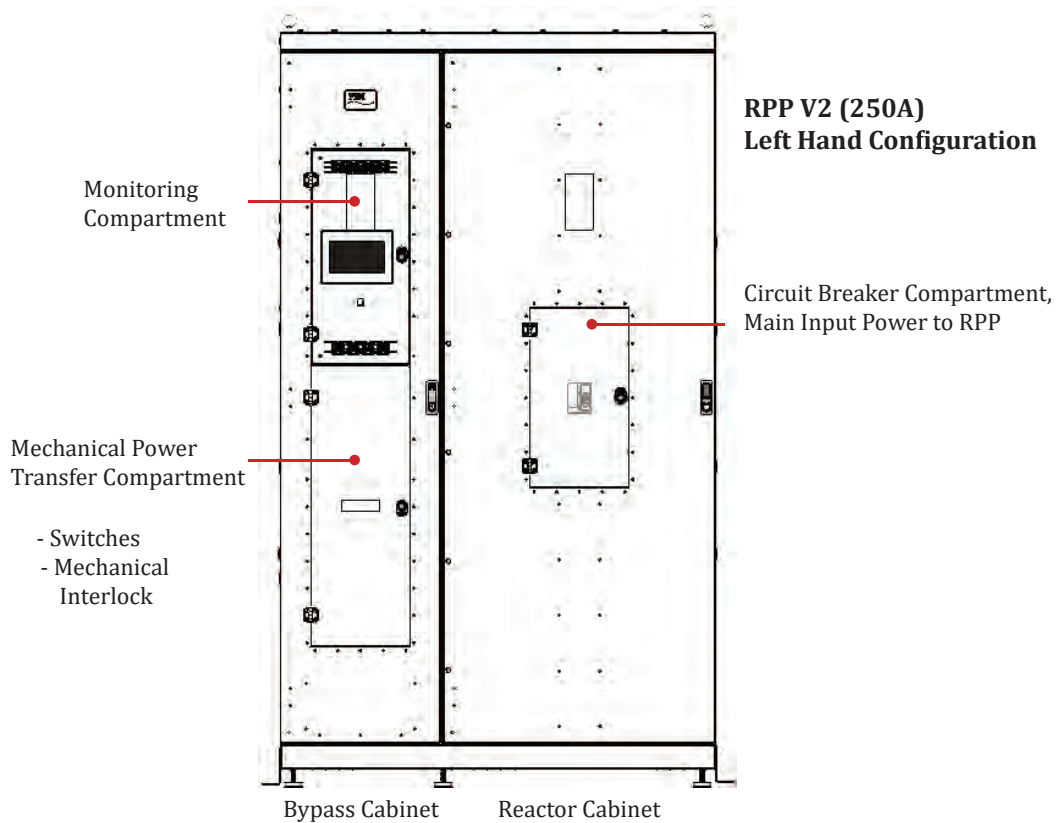
## 1.2 Description

The Reactor Power Panel V2 (RPP V2) contains a 250A Reactor Cabinet and an associated Bypass Cabinet. The two cabinets are bolted together for installation as a single unit. All power wiring between the Reactor and Bypass Cabinets is done in manufacturing.

When provided with a suitable reserve power source, the Bypass allows the reactor itself to be taken off line for maintenance without interrupting power to the load. The Bypass Cabinet has mechanically interlocked switches to transfer power between the RPP V2 power and reserve power. The

RPP V2 can be configured in manufacturing for left-hand (LH) or right-hand (RH) orientation, which determines whether the Bypass Cabinet is located on the LH or RH side.

**Figure 1. RPP V2 (250A) Left Hand Configuration**



## 1.3 Environmental Information

### 1.3.1 Operating Conditions

The RPP V2 can be operated within the following environmental conditions:

- Standard ambient operating temperature: 25°C (77°F).
- Ambient operating temperature range: 0°C to 40°C (32°F to 104°F)
- Relative humidity range: 0% to 95% non-condensing.
- Maximum altitude 3,300 ft. For operation above 3,300 ft., please contact the factory before ordering.

Maximum noise generation of the RPP V2 is 42 dBA.

### 1.3.2 Storage Conditions

If the RPP V2 is not to be immediately installed and energized, it should be carefully stored in a warm, dry environment, preferably a heated building with air circulation and a uniform temperature to prevent condensation. The RPP V2 should be stored in its factory protective coverings.

Storage temperature range must be within these extremes: -30°C to +70°C (-22°F to 158°F).

It is especially important that the reactor be free of condensation and protected from contamination. If the RPP V2 has been exposed to moisture, it should be dried out before being energized. Consult Eaton Service if the unit has been exposed to moisture or contamination.

## 1.4 Using This Manual

Read this manual thoroughly and make sure you understand the procedures before you attempt to install, set up, operate or carry out any maintenance work on this Eaton product.

Read through each procedure before beginning the procedure. Perform only those procedures that apply to the unit being installed or operated.

## 1.5 Conventions Used in This Manual

This manual uses these type conventions:



### NOTE

Some conventions only apply to display screens (if installed).

- **Bold type** highlights important concepts in discussions, key terms in procedures, and menu options, or represents a command or option that you type or enter at a prompt.
- *Italic type* highlights notes and new terms where they are defined.
- `Screen type` represents information that appears on the screen or LCD.

Icon	Description
	Information notes call attention to important features or instructions.
[Keys]	Brackets are used when referring to a specific key, such as [Enter] or [Ctrl].

## 1.6 Symbols, Controls, and Indicators

The following are examples of symbols used on the RPP or accessories to alert you to important information:



**RISK OF ELECTRIC SHOCK** - Observe the warning associated with the risk of electric shock symbol.



**CAUTION: REFER TO OPERATOR'S MANUAL** - Refer to your operator's manual for additional information, such as important operating and maintenance instructions.



This symbol indicates that you should not discard waste electrical or electronic equipment (WEEE) in the trash. For proper disposal, contact your local recycling/reuse or hazardous waste center.

## 1.7 Getting Help

If help is needed with any of the following:

- Scheduling initial startup
- Regional locations and telephone numbers
- A question about any of the information in this manual
- A question this manual does not answer

Please call the Eaton Help Desk at:

United States: **1-800-843-9433** or **1-919-870-3028**

Canada: **1-800-461-9166 ext 260**

All other countries: **Call your local service representative**

Please use the following e-mail for manual comments, suggestions, or to report a technical error in this manual.

**E-ESSDocumentation@eaton.com**

## 1.8 Warranty and End User License Agreement

To view the warranty please click on the link or copy the address to download from the Eaton website:

[Eaton Product Warranty](#)

<https://www.eaton.com/content/dam/eaton/products/backup-power-ups-surge-it-power-distribution/backup-power-ups/portfolio/eaton-three-phase-ups-warranty.pdf>

<https://www.eaton.com/content/dam/eaton/products/backup-power-ups-surge-it-power-distribution/backuppower-ups/portfolio/eaton-three-phase-ups-warranty.pdf>

To view the End User License Agreement please click on the link or copy the address to download from the Eaton website:

[Eaton End User License Agreement](#)

<https://www.eaton.com/content/dam/eaton/products/support-systems/software-and-cad-registration-form/eaton-end-user-software-license-agreement.pdf>



## Chapter 2 Safety

---



Follow safe electrical work practices:

- Severe or fatal injury can result from electrical shock during contact with high voltage conductors, monitoring PCBs, or similar equipment.
- Disconnect power before drilling holes, attaching conduit, and attaching other power distribution equipment.
- Disconnect and lock-out all power supplying equipment before working on or installing components.
- Use a properly rated voltage sensing device to confirm power is OFF.
- Leave ample space for attaching and routing wires.
- Use Lock Out/Tag Out procedures.
- Wear suitable personal protective clothing and use protective equipment for performing mechanical and electrical installations.
- Install equipment in an appropriate electrical environment per local regulations.



## Chapter 3 Installation

### 3.1 Receiving and Unpacking the RPP

RPP V2 units are shipped as fully assembled units with internal power wiring completed. Units are bolted to shipping pallets and protected by two layers of external plastic covering. The RPP is first covered by a large plastic bag and then shrink-wrapped. Finally the unit is secured to the pallet with metal retaining bands.

For moving the RPP V2 unit on its pallet, Eaton recommends that you leave the retaining bands intact until you have moved the RPP to a convenient location for removing it from its pallet.

**NOTE**

Inspect the shipped unit twice, upon receipt and after removing packaging materials.

---

1. Upon receiving an RPP V2 pallet and before removing packaging, inspect the packaging for visible damage. If damage is evident notify the shipping company and Eaton (see [1.7 Getting Help](#) or Eaton contact information).

File any damage claims with the shipping company at time of delivery. Damage must be noted on the bill of lading. Failure to properly document all damage may result in the unit's warranty being voided.

2. Carefully cut the retaining bands, making sure that they do not scrape the exterior of the unit or scratch the paint.

---

**WARNING**

---

- Metal retaining bands are under tension. Exercise caution when cutting them.
  - Wear protective clothing including eye, face, and hand protection when cutting retaining bands!
- 

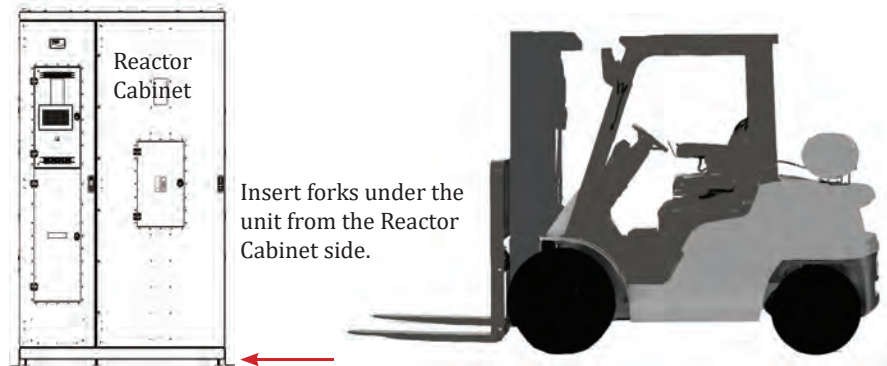
### 3.2 Moving the RPP V2 Unit

To move the RPP off the pallet with a forklift or pallet jack, do the following:

1. The RPP V2 unit is bolted to its pallet using (2) seismic brackets. With the RPP pallet resting on the floor, remove the seismic brackets and bolts and retain them for unit installation
2. Insert forklift or pallet jack forks under the RPP V2 Cabinet at the REACTOR CABINET SIDE. (This may be the left or right side depending on configuration.) Inserting forks from the Reactor Cabinet side minimizes the risk of damaging the unit's casters and provides better balance because the Reactor Cabinet is the heavier side. DO NOT INSERT FORKS FROM THE FRONT OR REAR OF THE UNIT.
3. Move the RPP V2 unit as close to its installation location as you can and withdraw the forklift.
4. Roll the RPP on its casters to its installation location.

**Figure 2. RPP Forklift Positioning**

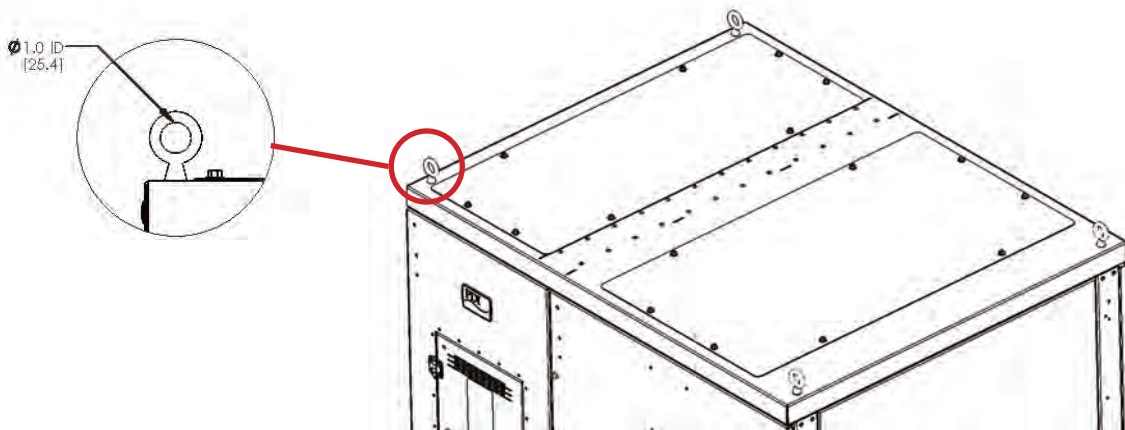
Height: 83.2" [2113.3] (with leveling feet)  
Width (front): 48" [1219.2]  
Depth (side): 38" [965.2]  
Weight: 1300 lbs. [590 kg.] approx.



NOTE: Measurements in brackets are millimeters unless specified otherwise.

The unit can also be moved with a hoist. The unit has (4) eye bolts at top corners for rigging hoist cables. The eye bolts can be removed after the unit is placed and attached to the floor.

**Figure 3. RPP Hoist Attachments**



### 3.3 Clearances and Door Swing

**Clearances:**

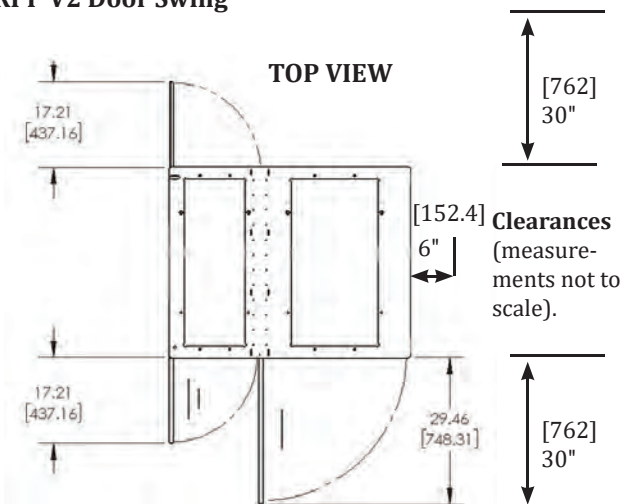
- Service clearance, front and rear: 30" [762 mm]
- Ventilation clearance: min. 6" [152.4 mm] front, rear, and one side (can be either side)

**Door Swing:** The Bypass Cabinet can be on the left-hand (LH) or right-hand (RH) side of the combined unit as you face the unit. In LH units, front and rear doors are hinged on the left. In RH units, doors are hinged on the right. Door swing always opens from the center of the unit outward.

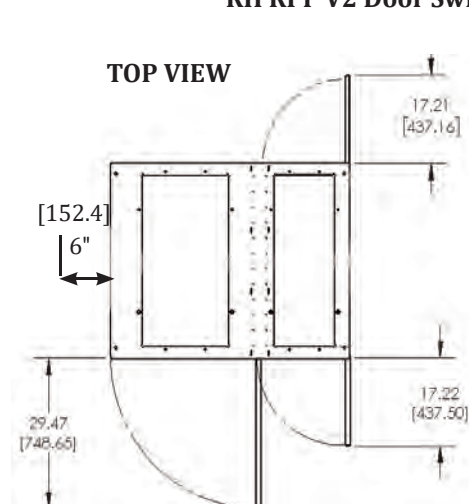


Figure 4. Door Swing Measurements

## LH RPP V2 Door Swing



## RH RPP V2 Door Swing



### 3.4 Anchoring the RPP to the Floor

After moving the RPP V2 unit to its installation location, secure it to the floor:

1. Each unit has (6) screw-adjustable leveling feet. Adjust feet to make the unit rest level and stable on the floor.

---

**CAUTION**

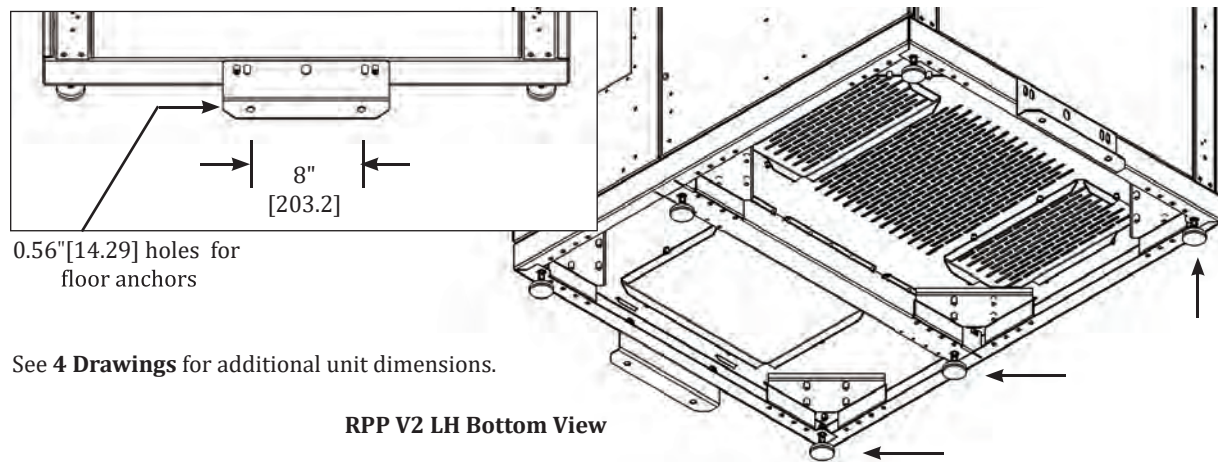
---

Do not screw leveling feet completely out of their holes.

---

2. Reattach the (2) seismic braces that you removed when unbolting the RPP from its pallet using the hardware you retained (see [3.2 Moving the RPP V2 Unit](#)). The seismic braces must be reattached on both the left and right sides of the RPP.
3. Secure the seismic braces to floor anchors. The installer must provide floor anchors.

**Figure 5. Floor Anchor Positions**



### 3.5 Cabling

---

**CAUTION**

---

A licensed electrician must install the RPP V2 unit and connect external wiring.

---

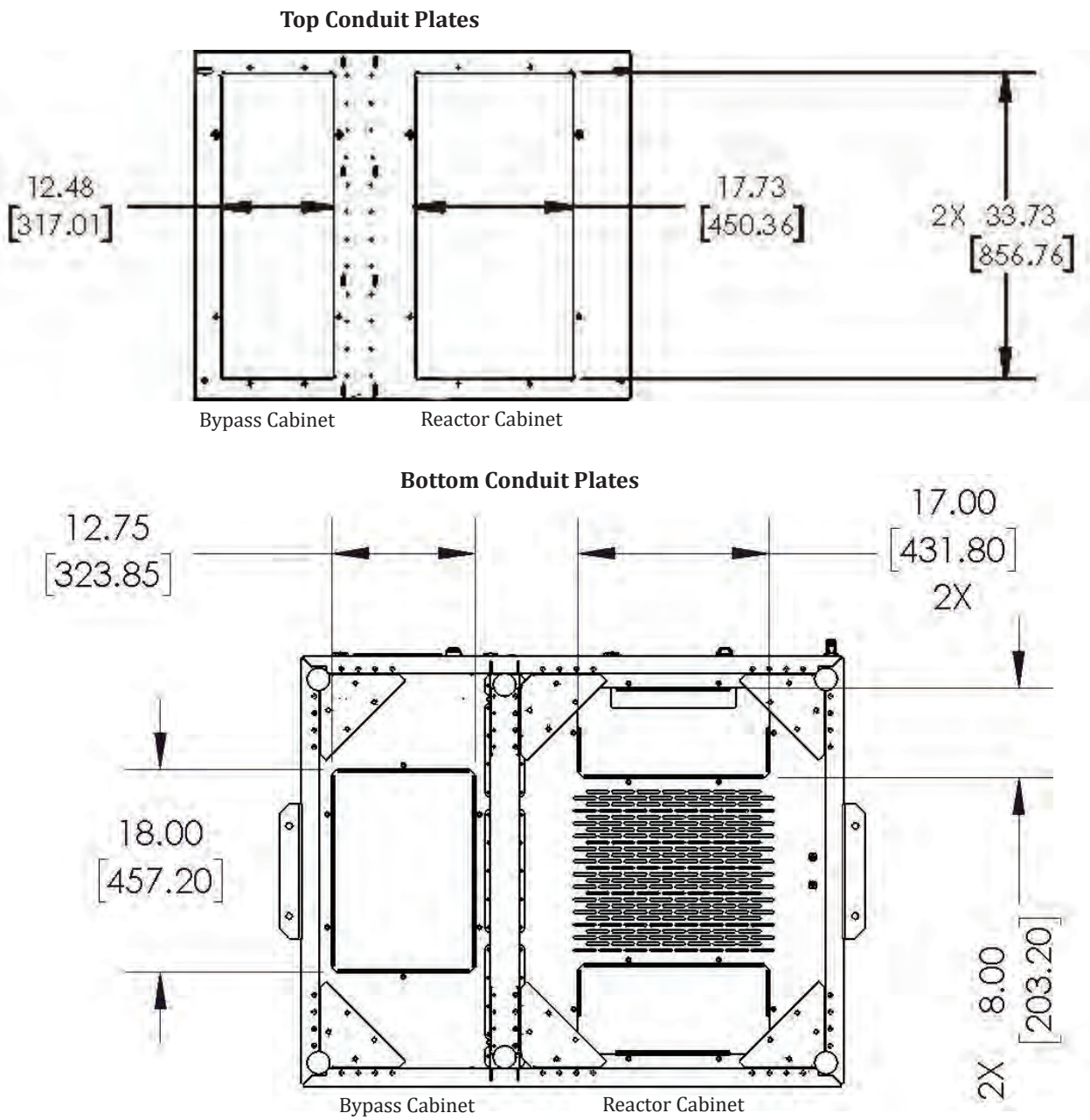
#### 3.5.1 Cable Entry

Power wiring between the Reactor Cabinet and the Bypass Cabinet is completed in manufacturing. Customers must make their own external power and monitoring connections.

Cable entry/exit can be from the top or bottom:

- Top and bottom conduit plates on both cabinets are removable.
- Conduit plates do not have knock-outs. Installers must make their own conduit cut-outs.
- Sufficient conduit space is available to allow RPP V2 units to be daisy-chained to a reserve power source.

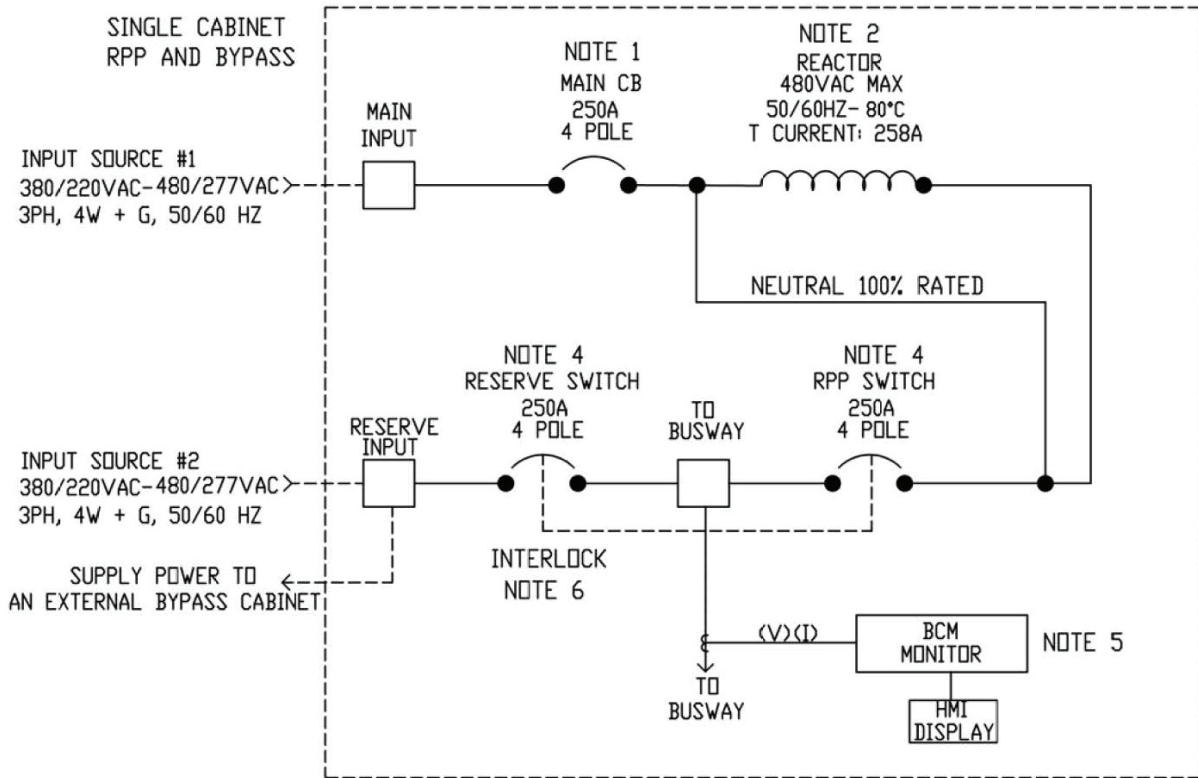
Figure 6. RPP Conduit Entry



### 3.5.2 RPP V2 One-Line Diagram

**NOTE** Power wiring and grounding must comply with NEC and applicable local codes.

**Figure 7. RPP V2 One-Line Diagram**



- 6. MECHANICAL POWER TRANSFER BAR.
- 5. MONITOR SYSTEM: BCM AND HMI DISPLAY.
- 4. RESERVE SWITCH AND RPP SWITCH: SEE TABLE ABOVE
- 3. SWITCHBOARD CABINET STANDARD: UL 891 AND IEC 61439
- 2. HARMONIC FILTERING CURRENT LIMITING REACTOR -158 uH +/- .  
AIR CORE INDUCTANCE OF 73.5 uH -3% +10%, TEMPERATURE RISE 80°C
- 1. MAIN CB: SEE TABLE

NOTES:

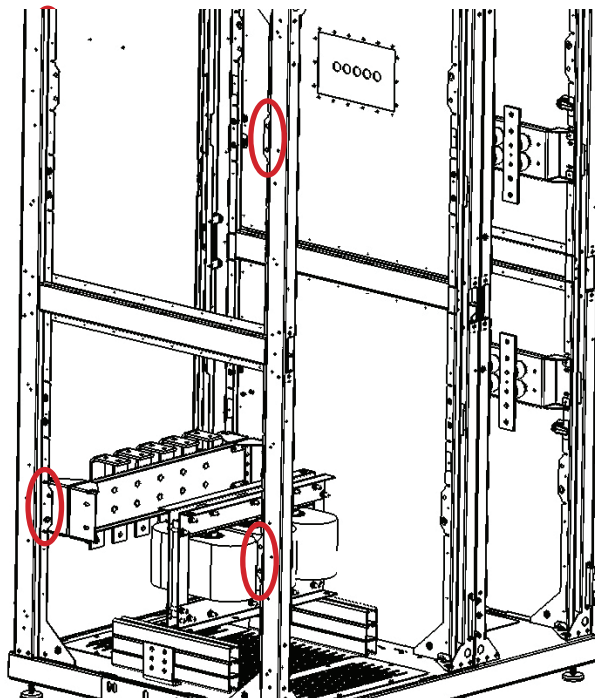
INPUT CB AND SWITCHES MANUFACTURER				
MANUFACTURER	DESCRIPTION	RATED	MANUF P/N	SKU P/N
EATON INPUT	4 POLE, 250A	100% RATED	JGH4250336C	15200001-ETN
EATON SWITCH	4 POLE, 600A	100% RATED	L6K4630KSG	15200001-ETN
SQ D INPUT	4 POLE, 250A	100% RATED	LJL46250CU31X	15200001-S0D
SQ D SWITCH	4 POLE, 400A	100% RATED	LGL46000S40X	15200001-S0D

### 3.5.3 Relocating Input Bus Bars

To better align with cable entry in the Reactor Cabinet, Input Bus Bars can be relocated to any of (3) positions:

- Bottom front (standard position)
- Bottom rear
- Top rear

**Figure 8. Input Bus Bar Positions**



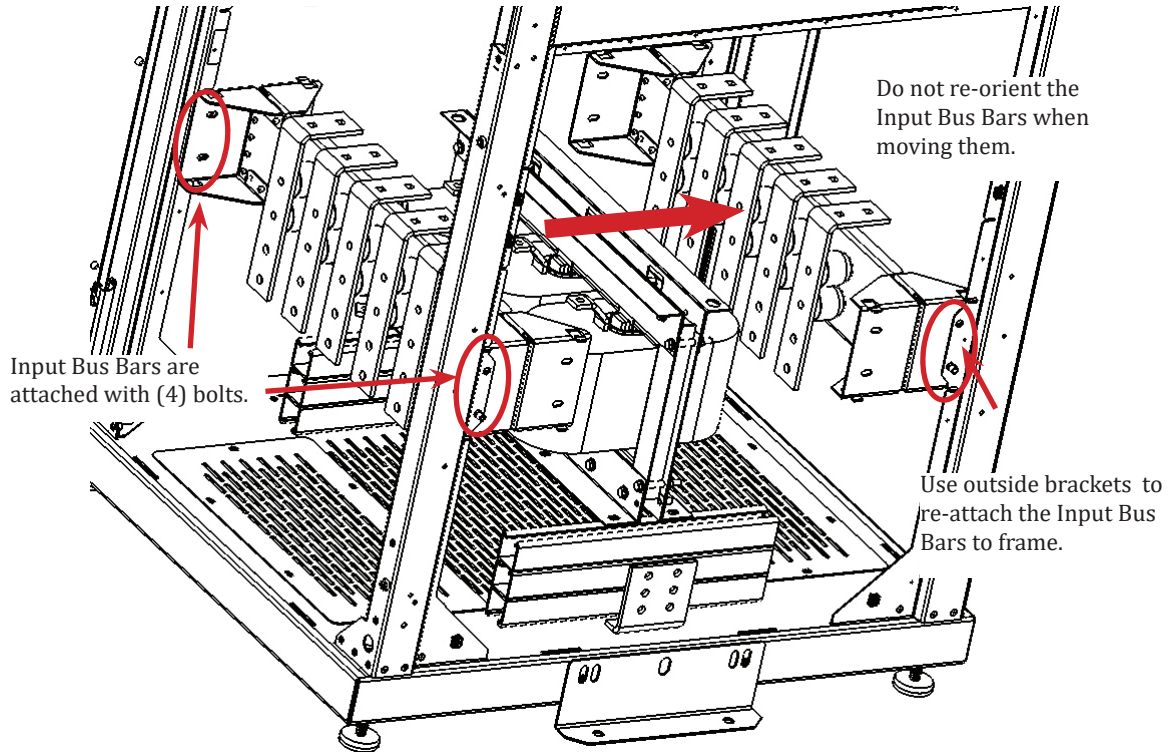
**Input Bus Bars can be relocated at the customer site to any of (3) positions.**

Input Bus Bars cannot be relocated to the top front position because door components are in the way.

To relocate Input Bus Bars, do the following:

1. Remove (4) bolts attaching the Input Bus Bars brackets to the Reactor Cabinet frame. Retain attachment hardware.
2. Do not detach the cables connecting the reactor to the bus bars. Do not change the orientation of the Input Bus Bar assembly. Brackets allow attachment from front or back.
3. Use retained (4) bolts and associated attachment hardware to reattach the Input Bus Bars to your selected location.

**Figure 9. Input Bus Bar Attachment**



### 3.5.4 External Cabling

Installers must connect external power cables for these functions:

1. Ground (at Reactor Cabinet)
2. Power to load (at Bypass Cabinet)
3. Reserve input power (at Bypass Cabinet) (multiple Bypass Cabinets can be daisy-chained from a single reserve power source)
4. Input power (at Reactor Cabinet)

Up to MCM350 MCM CU wire can be accommodated for reactor input and reserve input power connections.

Cables should be zip-tied to the glastic lashing bar inside the unit. The lashing bar inhibits cable movement during short circuit events.

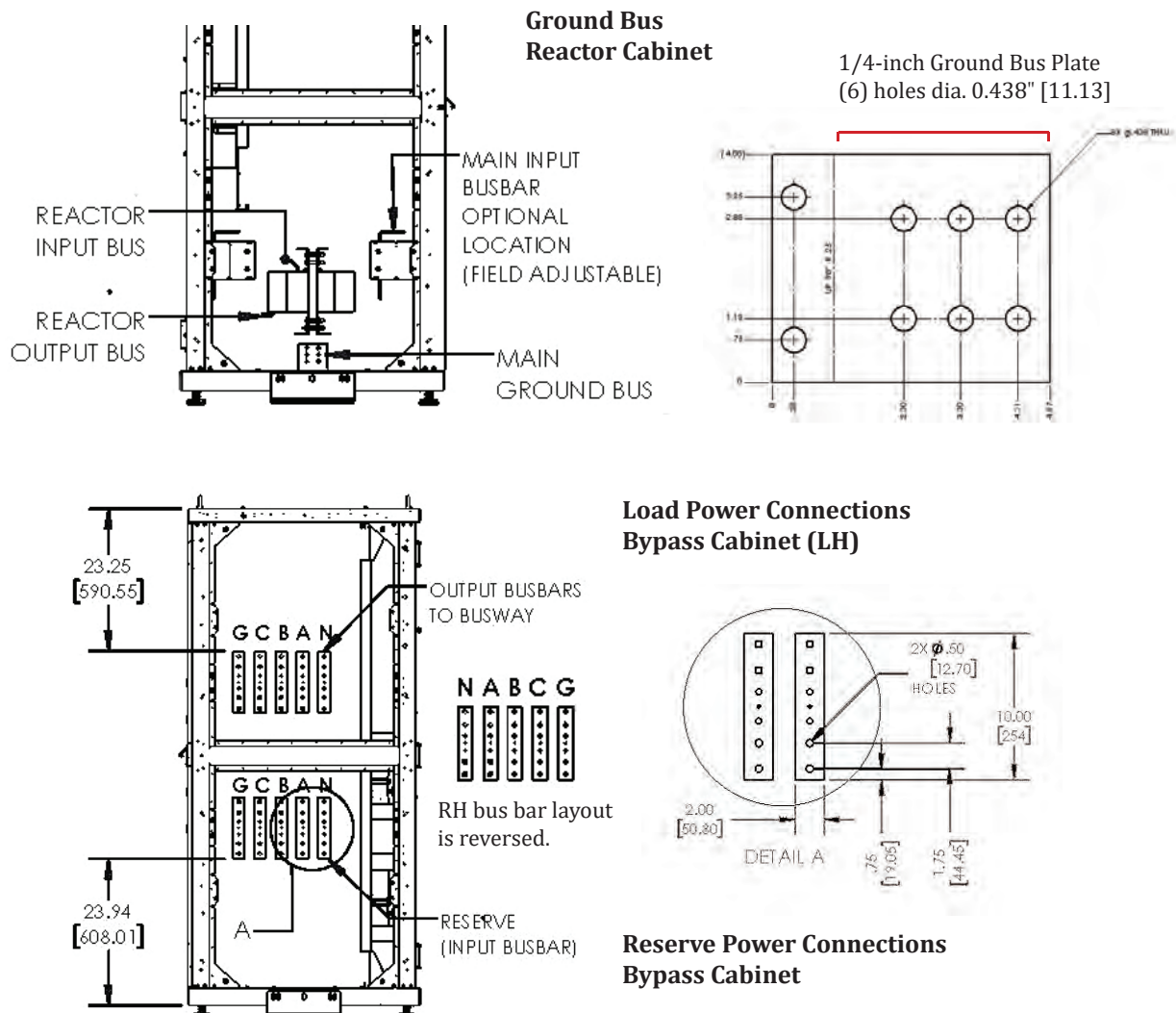
---

**⚠ WARNING**

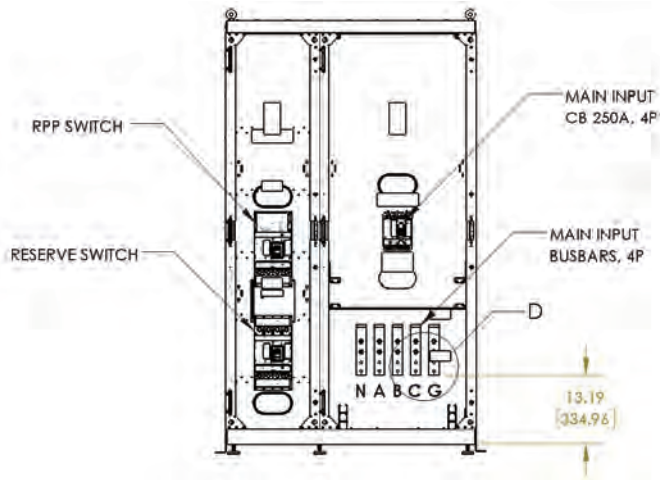
---

- Power to all power cables being connected must be turned off and locked out before making electrical connections to the RPP V2.
  - Use a voltage meter to confirm that power is off.
-

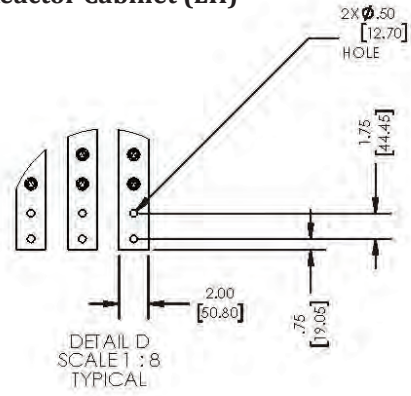
Figure 10. Cabinet External Connections



**Figure 11. Input Power Connections**



**Input Power Connections  
Reactor Cabinet (LH)**





## Chapter 4 Bypass Operation

Operation of the RPP V2 Bypass consists of switching power between main RPP power and reserve power. Power switches and the Mechanical Interlock are in the Mechanical Transfer Compartment on the front of the Bypass Cabinet. The Mechanical Interlock allows only (1) switch to be closed at a time.

To switch power between power sources, do the following:

1. Open the Mechanical Transfer Compartment Door.
2. \Open (turn off) both power switches in the Compartment.
3. Depress the latch on one or both sides of the Mechanical Interlock and slide the Mechanical Interlock from one side to the other until the latch catches. The position of the Mechanical Interlock determines which source can power the load:
  - Right=RPP (250A reactor) powers the load.
  - Left=Reserve powers the load.
4. Close (turn on) the RPP Switch or the Reserve Switch according to which power source will power the load.

---

**CAUTION**

---

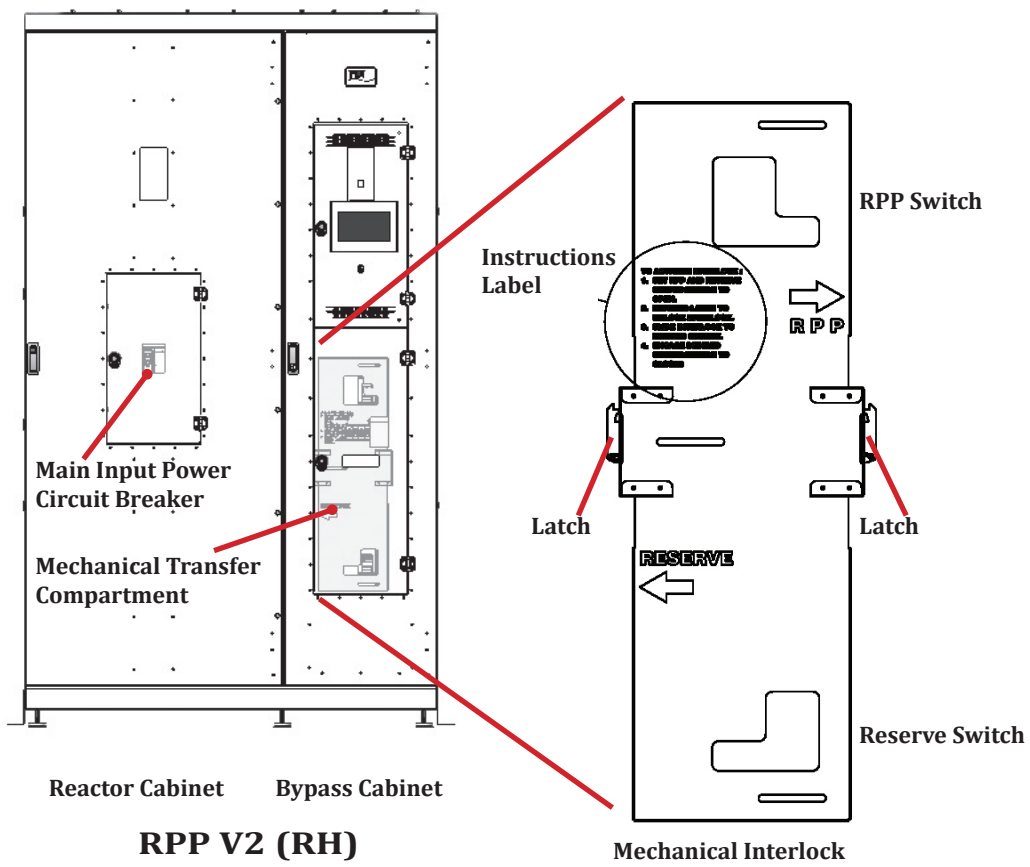
The power-switching operation must be conducted in less than 60 seconds to prevent loss of power to the load.

---

5. Close the Mechanical Transfer Compartment Door.

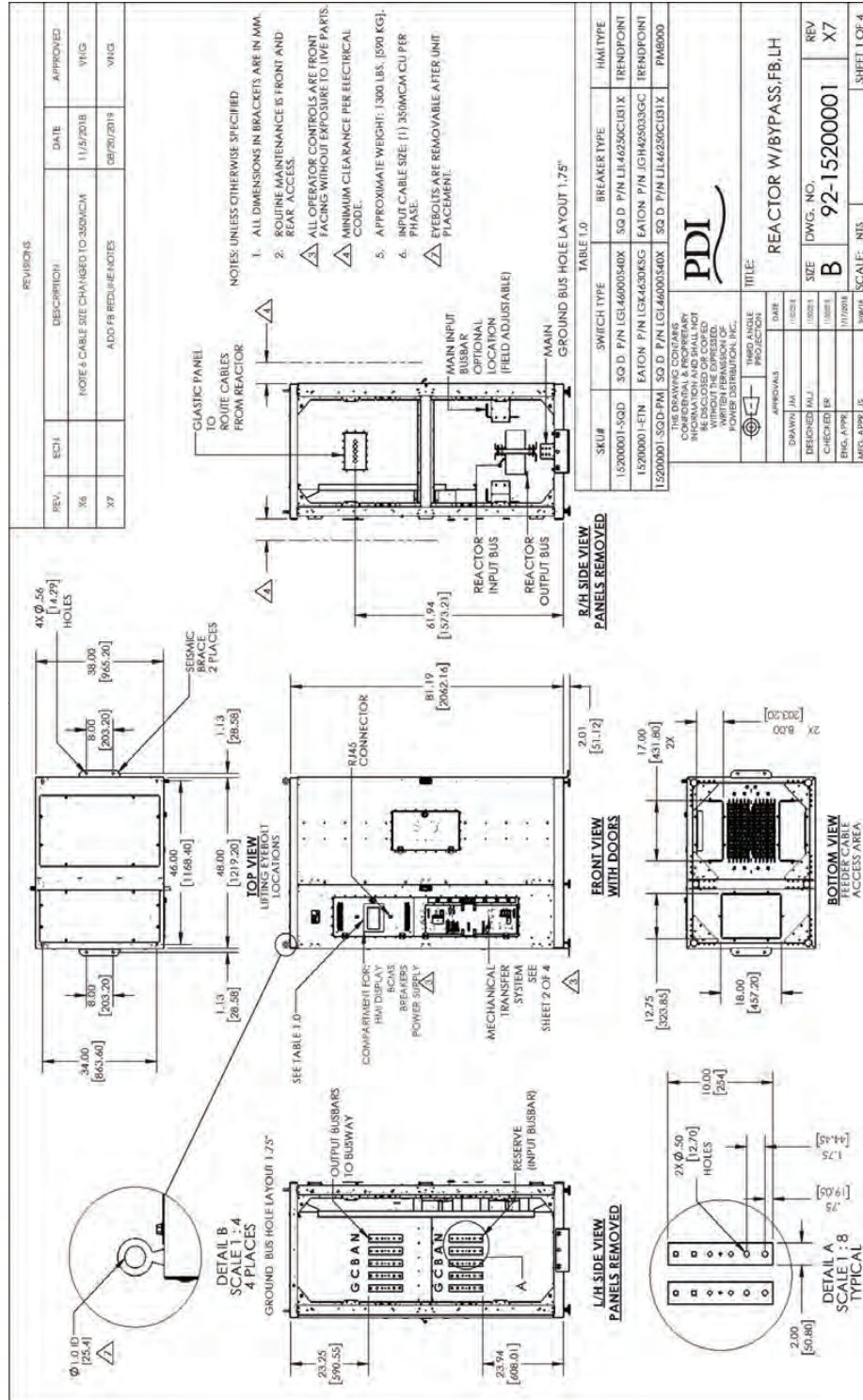
The Reactor Cabinet also has a circuit breaker controlling main power to the Reactor Cabinet.

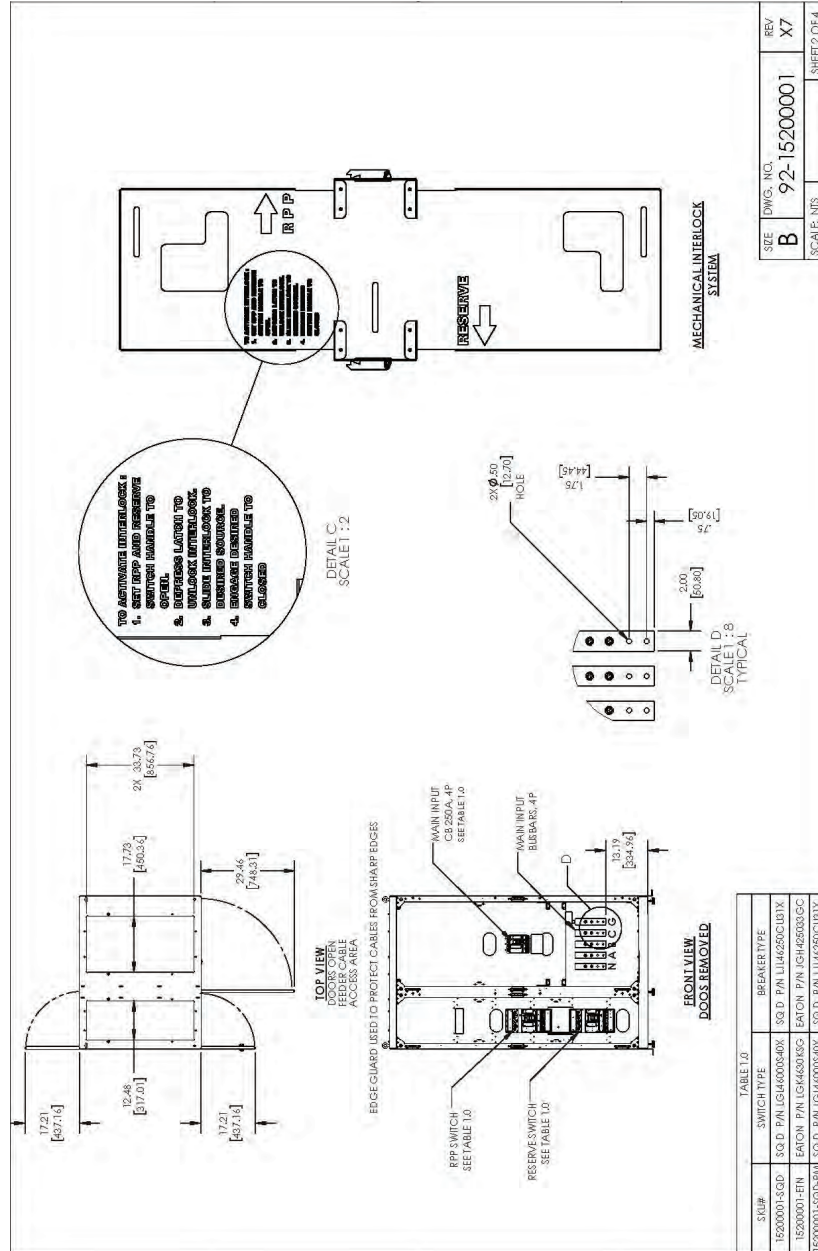
Figure 12. Mechanical Transfer Compartment



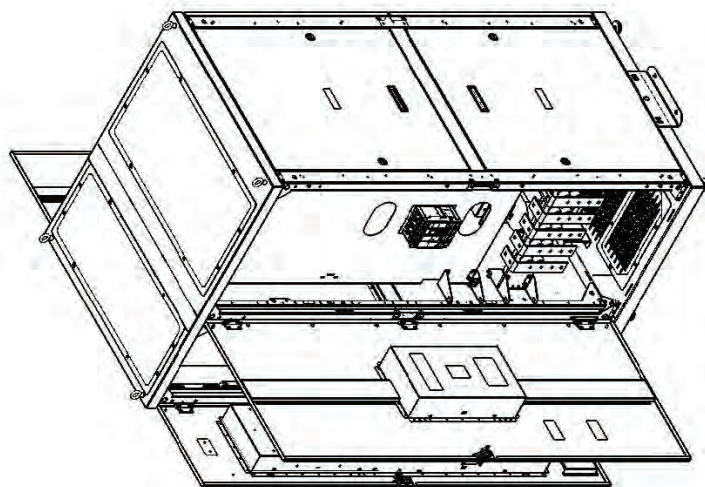
# Chapter 5 Drawings

## 5.1 RPP V2 Left-Hand Configuration Drawings



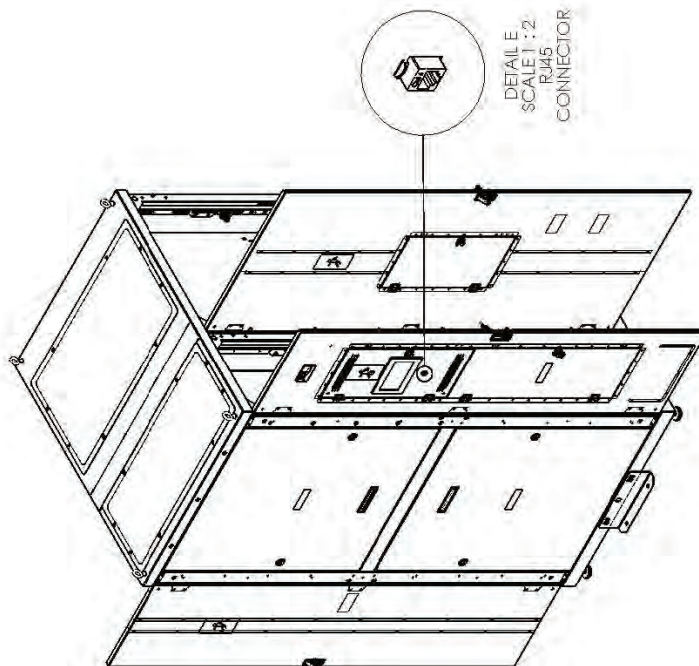


SEE DWG. NO.	REV
B	X7
SCALE: NTS	SHEET 2 OF 4



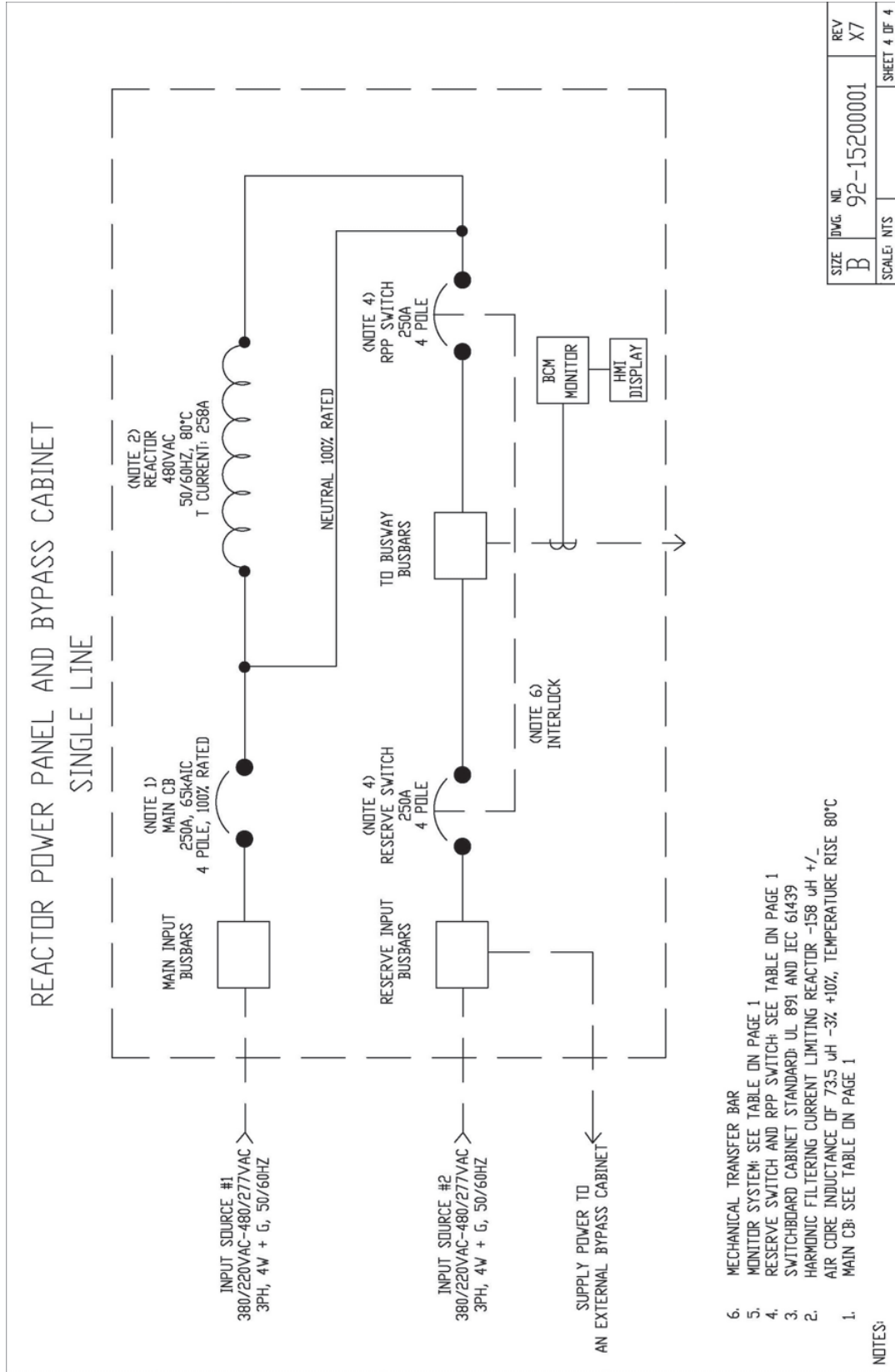
DOORS HAVE BONDING WIRES FOR PROPER GROUNDING

**DOORS OPEN RIGHT SIDE VIEW**

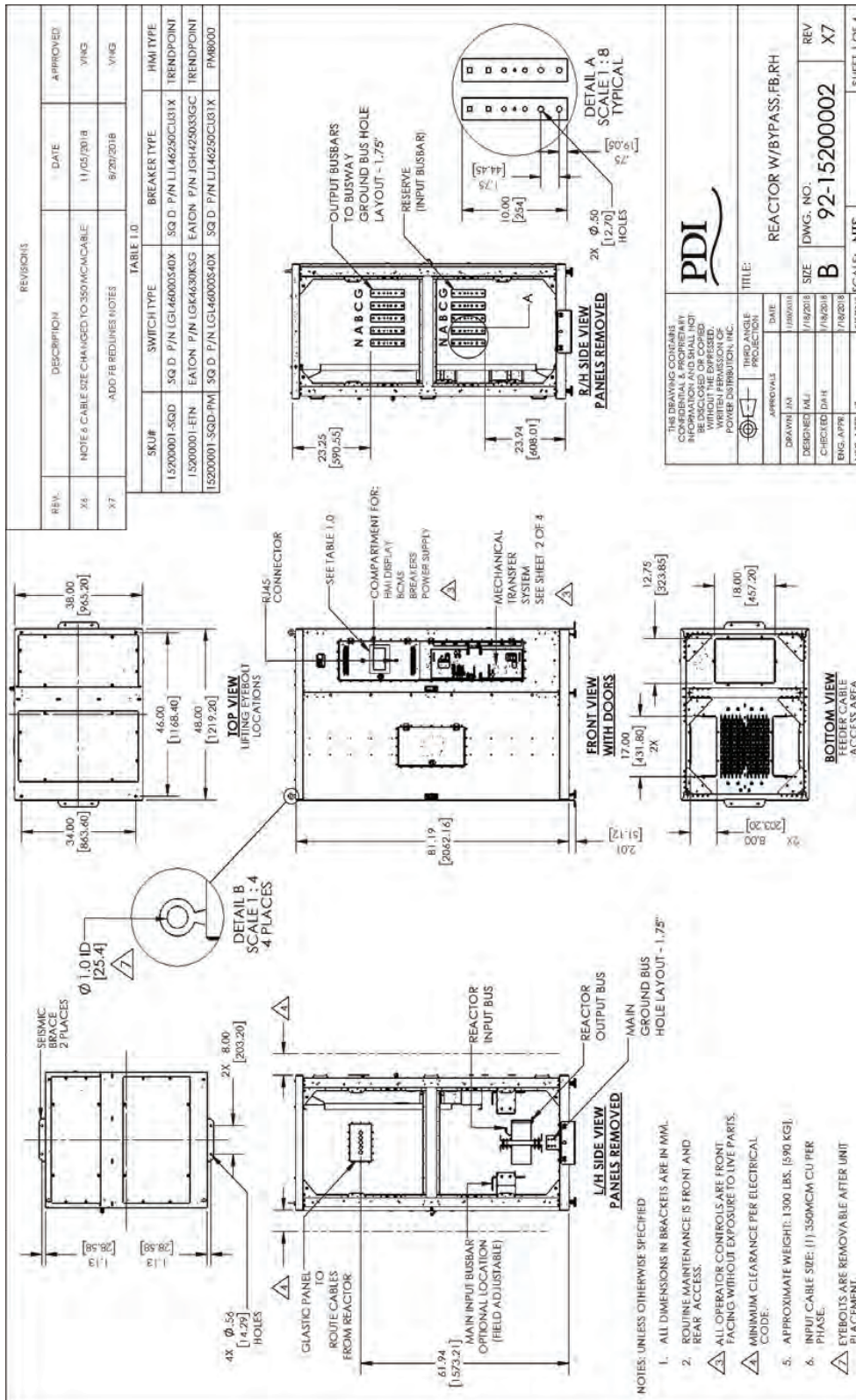


**DOORS OPEN LEFT SIDE VIEW**

SIZE	DWG. NO.	REV.
B	92-15200001	X7
SCALE: NTS		SHEET 3 OF 4



5.2 RPP V2 Right-Hand Configuration Drawings



**PDI**

THIS DRAWING CONTAINS CONFIDENTIAL & PROPRIETARY INFORMATION AND SHALL NOT BE REPRODUCED OR TRANSMITTED IN ANY FORM OR BY ANY MEANS WITHOUT THE EXPRESSED WRITTEN PERMISSION OF POWER DISTRIBUTION, INC.

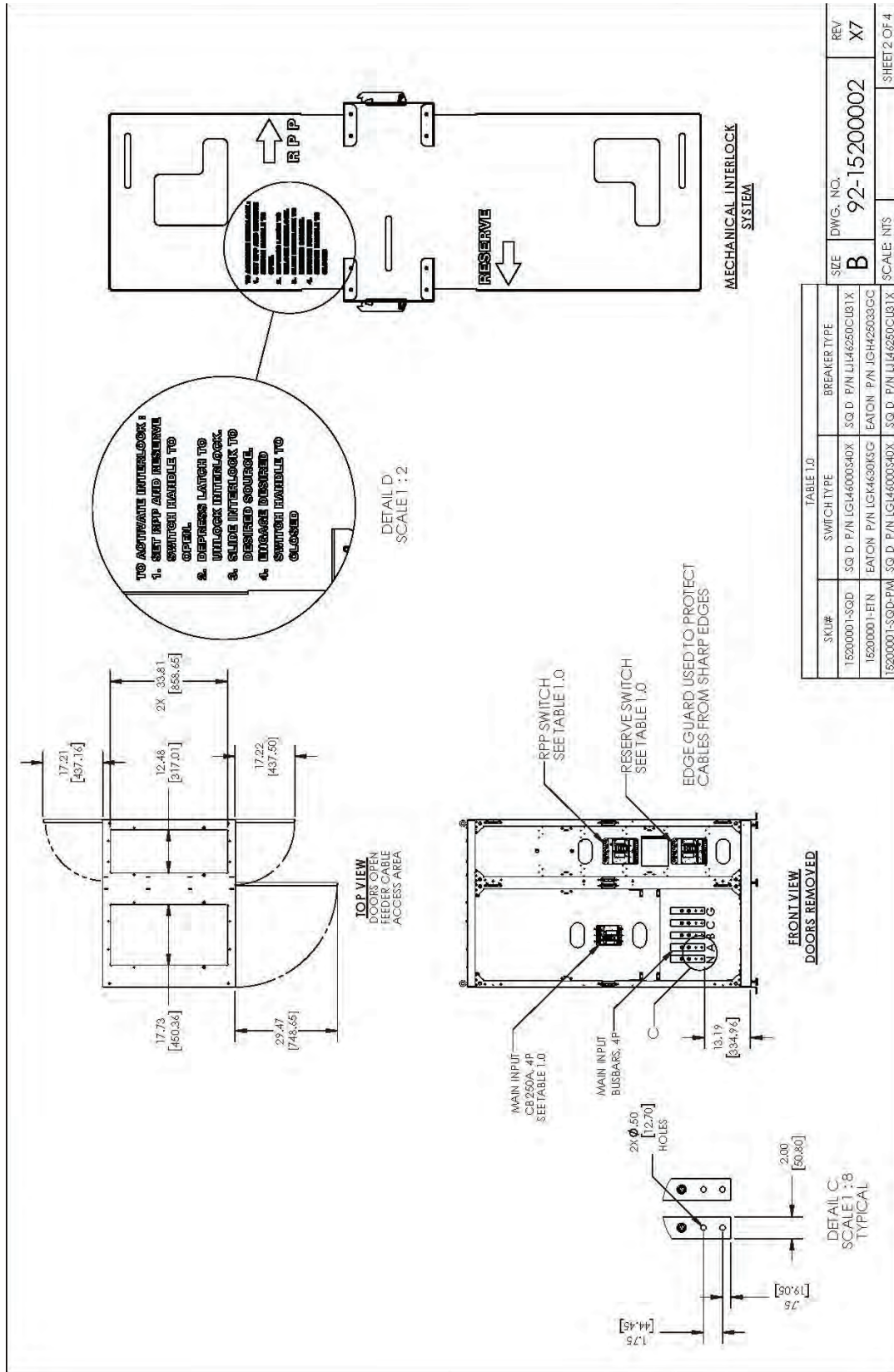
APPROVALS	DATE
DESIGNED: JMI	11/08/2018
CHECKED: DHT	11/08/2018
ENG. APPR: JMI	11/08/2018
MFG. APPR: JMI	11/08/2018

TITLE: REACTOR W/BYPASS:FB,RH

SIZE	B
DWG. NO.	92-15200002
REV	X7

SCALE: NTS

SHEET 1 OF 4



SKU#	SWITCH TYPE	BREAKER TYPE
15200001-SQD	SQ D P/N LG46000340X	SQ D P/N LJ46250CUBTX
15200001-ETN	ETN P/N LG464905G	ETN P/N JGH42503GCC
15200001-SQD-PM	SQ D P/N LG46000340X	SQ D P/N LJ46250CUBTX

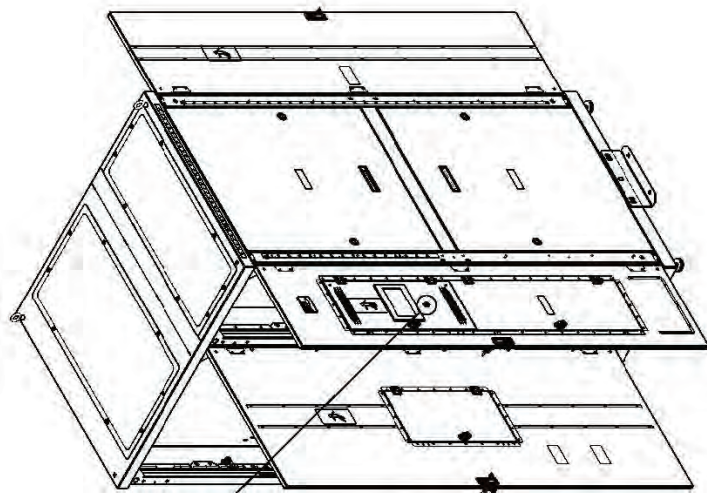
  

SIZE	DWG. NO.	REV
B	92-15200002	X7

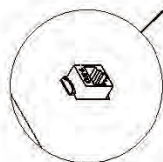
  

SCALE: NTS	SHEET 2 OF 4
------------	--------------

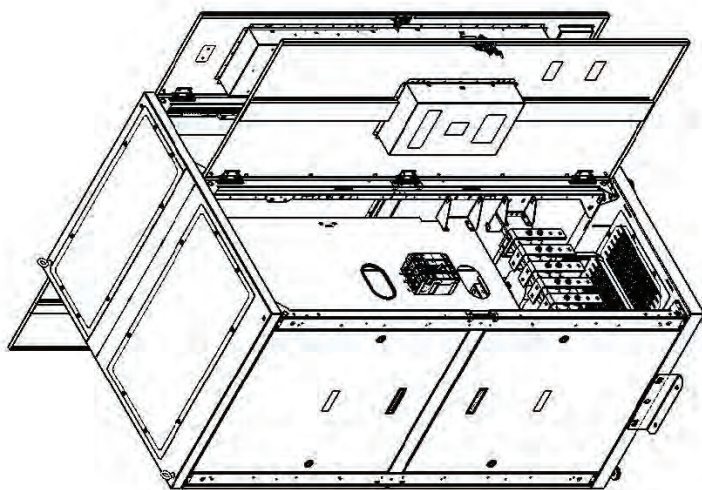




**DOORS OPEN RIGHT SIDE VIEW**

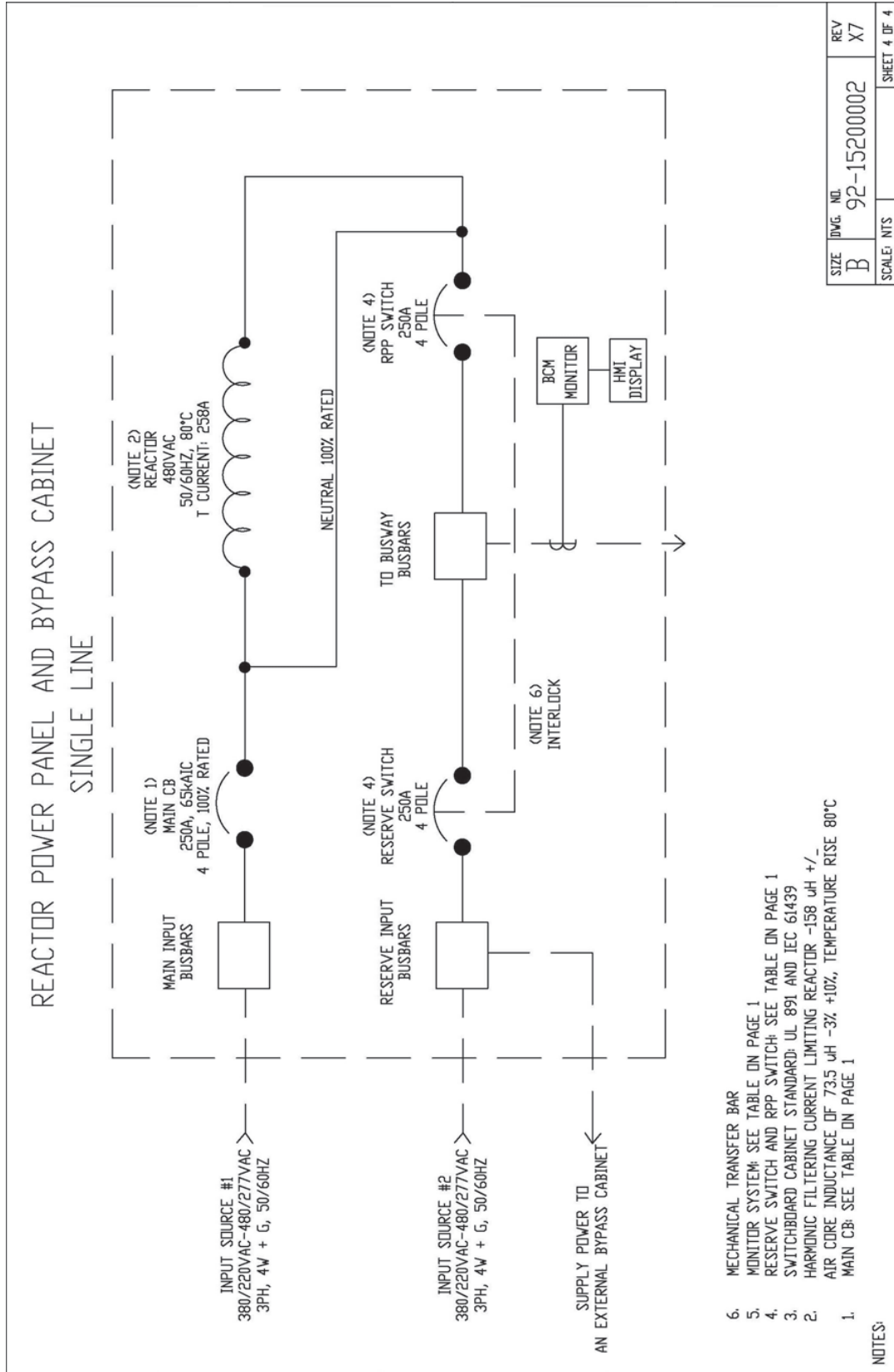


DETAIL  
SCALE: 2  
R145  
CONNECTOR



DOORS HAVE BONDING CABLES FOR PROPER GROUNDING  
**DOORS OPEN LEFT SIDE VIEW**

SIZE	DWG. NO.	REV.
B	92-15200002	X7
SCALE: NTS		SHEET 3 OF 4



## Chapter 6 Eaton Service Contracts

Eaton Service contracts help to provide the added insurance that the reliability of your critical power systems is intact. By following our stringent maintenance procedures, Eaton’s factory trained Customer Support Engineers provide the added assurance for the availability of critical systems, thereby maximizing the company’s profitability. See below for further details.

### 6.1 The Service Promise

With factory-trained technicians in every major city in North America, Eaton can respond rapidly and provide on-site assistance in emergency down time situations. Eaton provides telephone support 24 hours a day, 7 days a week with a direct line to Service (1-800-843-9433).

### 6.2 Preventive Maintenance

During a preventive maintenance visit, Eaton technicians inspect, test, calibrate, update and clean components, as well as update software as applicable. You’ll receive a report at the end of the visit detailing the results of the inspection and specific recommendations for remedial actions, proactive replacements, and upgrades.

### 6.3 Eaton Provides Flexibility and Commitment

- We understand that service plans are not “one size fits all.” That’s why we offer a broad range of service options, designed to meet the varied requirements and applications of businesses of all shapes and sizes. Eaton can modify your contract on variables such as number of PM visits per year, scope of coverage, response time and length of contract.
- Eaton employs 250+ field technicians with an average tenure of more than ten years. Eaton CSEs are experts on Eaton products and receive ongoing product training and certification. Our technicians have expertise in power, electrical engineering, software and connectivity, batteries, UPSs and related products, and can deliver advanced troubleshooting and a reduced mean time to repair.
- When you rely on an Eaton service plan, rest assured that every factory-trained field technician stocks a solid inventory of parts to remedy emergencies.

### 6.4 Time and Materials

In most cases the customer will be covered by startup service or Maintenance Contracts, however, there may be times when the customer needs Eaton service and lacks the benefits that these two packages provide. Therefore, Eaton provides Time and Material coverage for those in need of our customer support engineers.

### 6.5 Startup

At the initial startup of the Remote Power Panel, an Eaton factory-authorized technician is recommended to validate correct operation of the RPP. The product warranty may be voided if the correct startup procedures are not followed.

### 6.6 Infrared Scanning

To gain access to bus bars and cables for infrared scanning, open Bypass Cabinet or Reactor Cabinet Doors.

### 6.7 Spare Parts Kits

Spare parts kits are available for different RPP V2 internal configurations.

Part Number	Description
<b>EATON VERSION</b>	
CKB66923	4P,250A,35KA,480V,EATON,LUGS,CB

<b>Part Number</b>	<b>Description</b>
CKB66922	4P,400A,35KA,480V,EATON,LUGS,SWITCH
MET56605	METER,PQM,TRENDPOINT,ENKAPSIS
PWS56550	POWER SPPLY
<b>SQUARE D VERSION</b>	
CKB56737	4P,250A,35KA,480V,SQD,LUGS,CB
CKB56587	4P,400A,35KA,480V,SQD,LUGS,SWITCH
MET56605	METER,PQM,TRENDPOINT,ENKAPSIS
PWS56550	POWER SPPLY
<b>SQUARE D WITH PM8000 MONITOR VERSION</b>	
CKB56737	4P,250A,35KA,480V,SQD,LUGS,CB
CKB56587	4P,400A,35KA,480V,SQD,LUGS,SWITCH
MET57845	PWR MTR, SQD,SER-8000,CTRL
FUS57270	Midget, HLDR,FA,1A,600V
FUS57267	Midget, HLDR,FA,0.5A,600V





164001118 03