

NOTES:

1. OPERATOR INTERFACE PANEL.
2. MAIN INPUT CIRCUIT BREAKER.
3. (6) 400A SUBFEED CIRCUIT BREAKER.
4. (1)300 kVA TRANSFORMER
5. BCMS CIRCUIT BOARD (OPTIONAL).
6. RECOMMEND A MINIMUM OF 30" IN REAR OF UNIT FOR SERVICE & MAINTENANCE.
7. MINIMUM OF 36" CLEARANCE FOR DOOR SWING IN FRONT.
8. RECOMMEND 6" CLEARANCE BETWEEN VENTILATED SIDES AND WALL FOR PROPER COOLING.

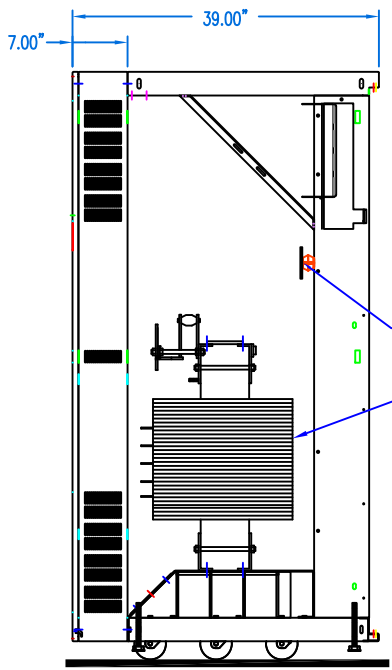

(DOOR AND COVERS REMOVED)

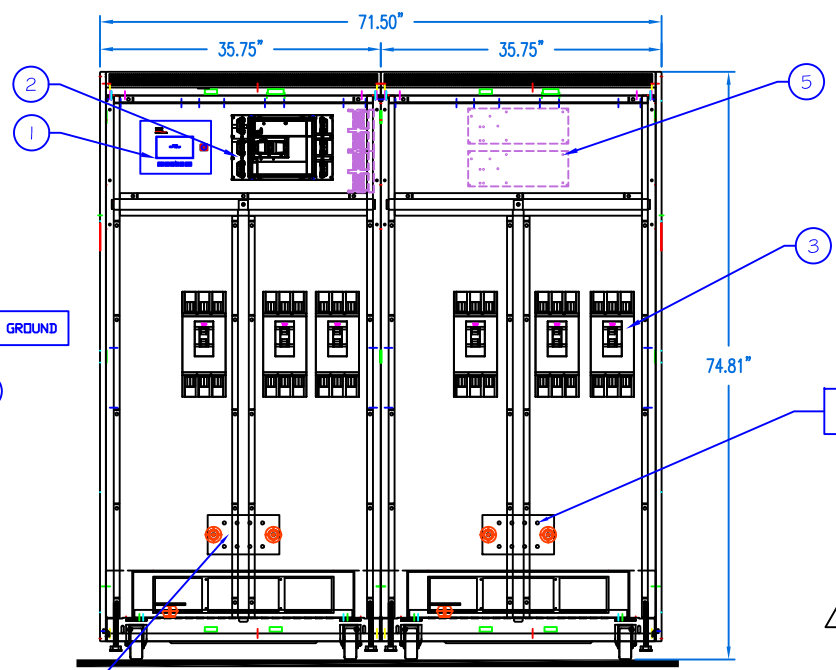

(DOOR AND COVERS REMOVED)

NEUTRAL BUS

△ 6/11/15 RAE ADJUSTED CKB LOCATION ADDED GROUND BUS LOCATION AND SHOW BOTTOM ENTRY/EXIT

THIS DRAWING CONTAINS CONFIDENTIAL & PROPRIETARY INFORMATION AND SHALL NOT BE DISCLOSED OR COPIED WITHOUT THE EXPRESSED WRITTEN PERMISSION OF POWER DISTRIBUTION INC.		TITLE PDU (200-300 kVA) W/ (x2) PDU FRAMES (6) 400A SUBFEED	
DWG. NUMBER PDU18243		1 OF 1	
DRAWN BY LJJ		REVISION	
DATE 4/16/15		-B-	