

REVISIONS			
REV.	DESCRIPTION	DATE	APPROVED

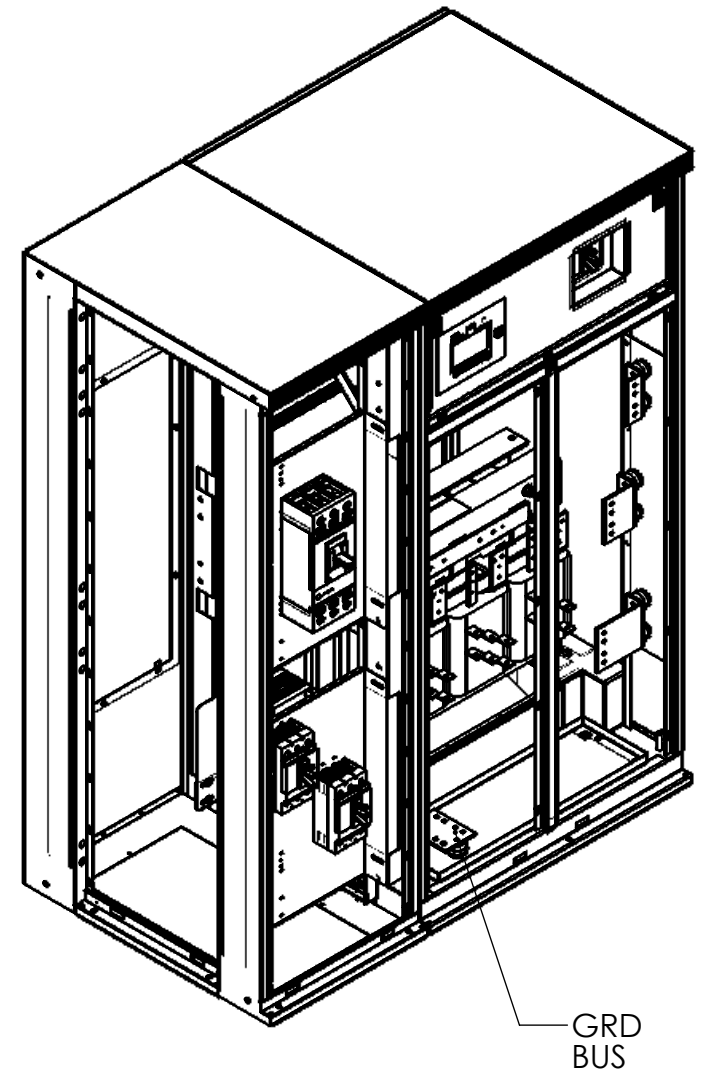

PANELS REMOVED

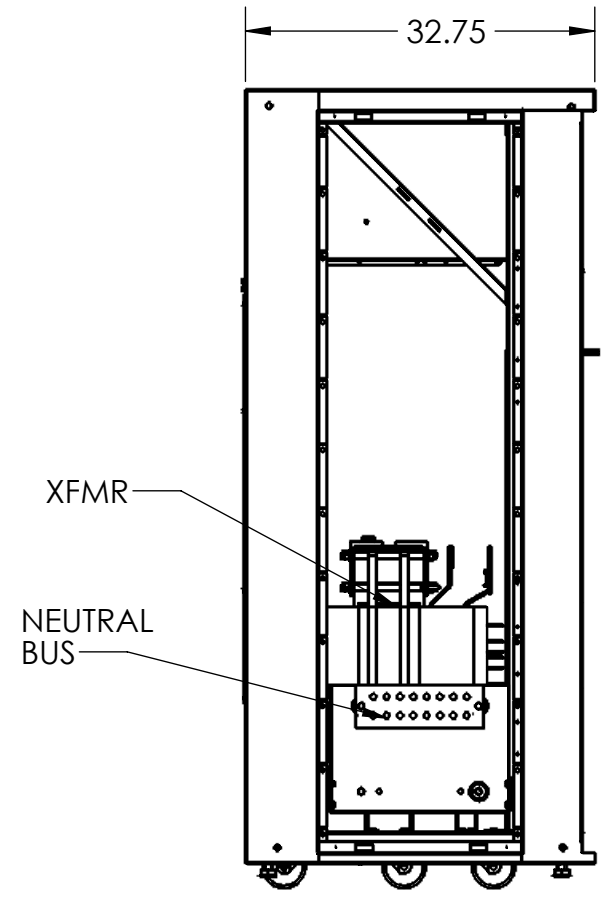

SIDE PANEL REMOVED

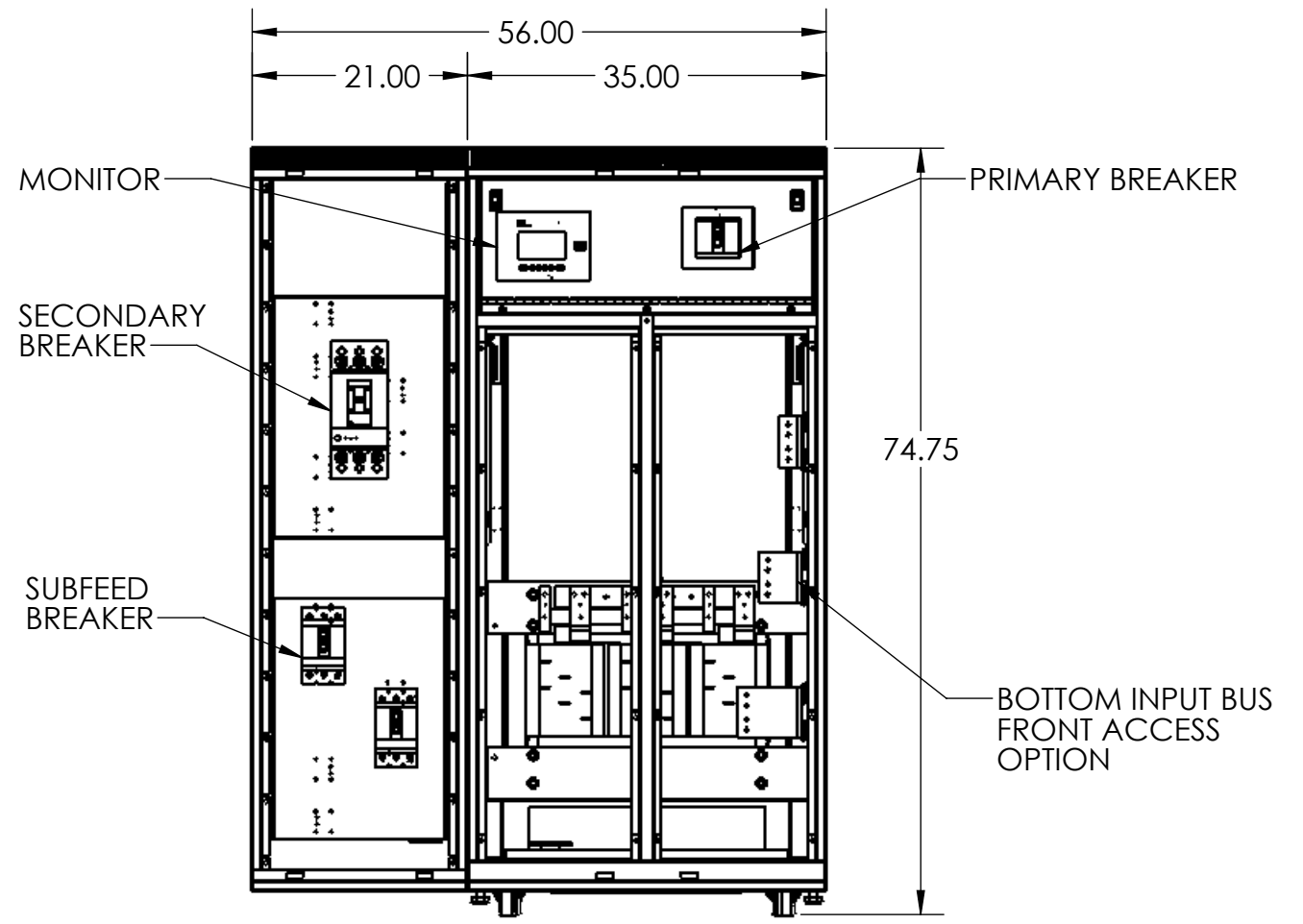

FRONT PANEL REMOVED

GENERAL SPECIFIED

CABINET CHARACTERISTIC:
ENCLOSURE : NEMA 1
LOCATION : INDOOR

MECHANICAL:
MATERIAL: STEEL
FINISH: EXTERIOR PANELS: PEARL WHITE - PHTI-60016
WEIGHT : 3000 LBS. APPROX.

ELECTRICAL:
TRANSFORMER : 150 kVA, K13, 115 C RISE.
INPUT : 208 VAC 3PH-4W W/GND @ 60 HZ, 400A (MAX) (2 EA. # 2/O-350 MCM CU)
OUTPUT : (2) 250A, 25KAIC BREAKER
SEE ONE LINE DWG18147-0 FOR MORE INFORMATION

ENVIRONMENTAL:
OPERATING AMBIENT TEMPERATURE 0°C TO 40°C (32°F TO 104°F)
RELATIVE HUMIDITY: 0% TO 95% NON-CONDENSING
ALTITUDE: 10,000 FT MAX

**NOT FOR PRODUCTION
PROPOSAL ONLY**

UNLESS OTHERWISE SPECIFIED:
DIMENSIONS ARE IN INCHES
[] IN MILLIMETER
ANGULAR: ±0.5° BEND ±1°
TWO PLACE DECIMAL ±0.02
THREE PLACE DECIMAL ±0.005

THIS DRAWING CONTAINS
CONFIDENTIAL & PROPRIETARY
INFORMATION AND SHALL NOT
BE DISCLOSED OR COPIED
WITHOUT THE EXPRESSED,
WRITTEN PERMISSION OF
SMITHS POWER



THIRD ANGLE PROJECTION		DO NOT SCALE DRAWING	
APPROVALS		DATE	
DRAWN	LJN	4/2/15	
CHECKED			
ENG. APPR.			

TITLE: Alterman/CPS ECHO - PDU		
SIZE B	DWG. NO. PDU18147	REV
PART NO.		SHEET 1 OF 2