

NEUTRAL BUS  
GROUND BUS

**NOTES:**

1. OPERATOR INTERFACE PANEL.
2. MAIN INPUT CIRCUIT BREAKER.
3. 800A I-LINE PANEL BOARD (HCM2364-8).
4. (1-10) 50-250A SUBFEEDS.
5. RECOMMEND A MINIMUM OF 6" IN REAR AND LEFT SIDE OF UNIT FOR VENTILATION.
6. MINIMUM OF 36" CLEARANCE FOR DOOR SWING IN FRONT.
7. MINIMUM OF 36" CLEARANCE FOR DOOR SWING ON RIGHT SIDE.

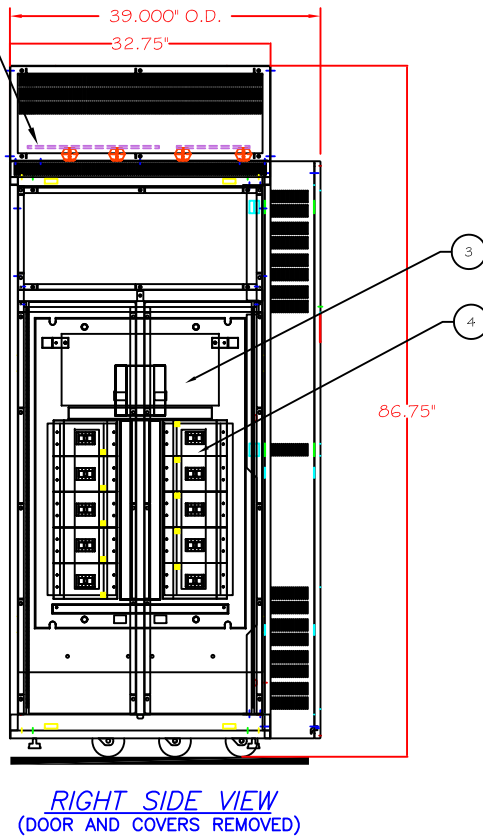
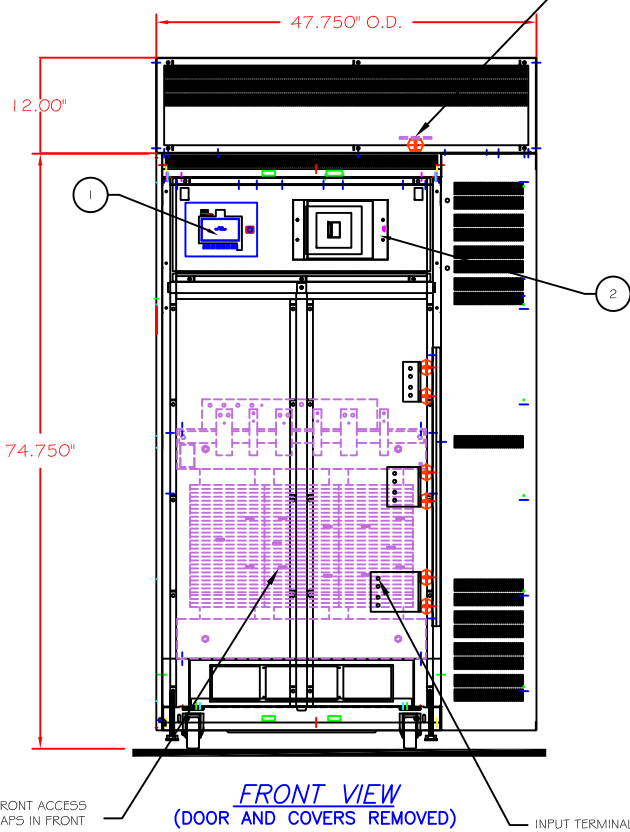

TOP ENTRY/EXIT

THIS DRAWING CONTAINS CONFIDENTIAL & PROPRIETARY INFORMATION AND SHALL NOT BE DISCLOSED OR COPIED WITHOUT THE EXPRESSED, WRITTEN PERMISSION OF POWER DISTRIBUTION INC.	TITLE		-OUTLINE-	
	PDU (200-300 kVA)		W/ RH 12" SIDECAR	
	800A I-LINE PANEL W/ (1-10) 50-250A SUBFEEDS			
	DWG. NUMBER	SHEET 1 OF 1	REVISION	
PDU18382		-A-		
DRAWN BY	RAE	CHECKED BY	KRH	
DATE	05-14-15	DATE	05-14-15	

