

8 7 6 5 4 3 2 1

D

C

B

A

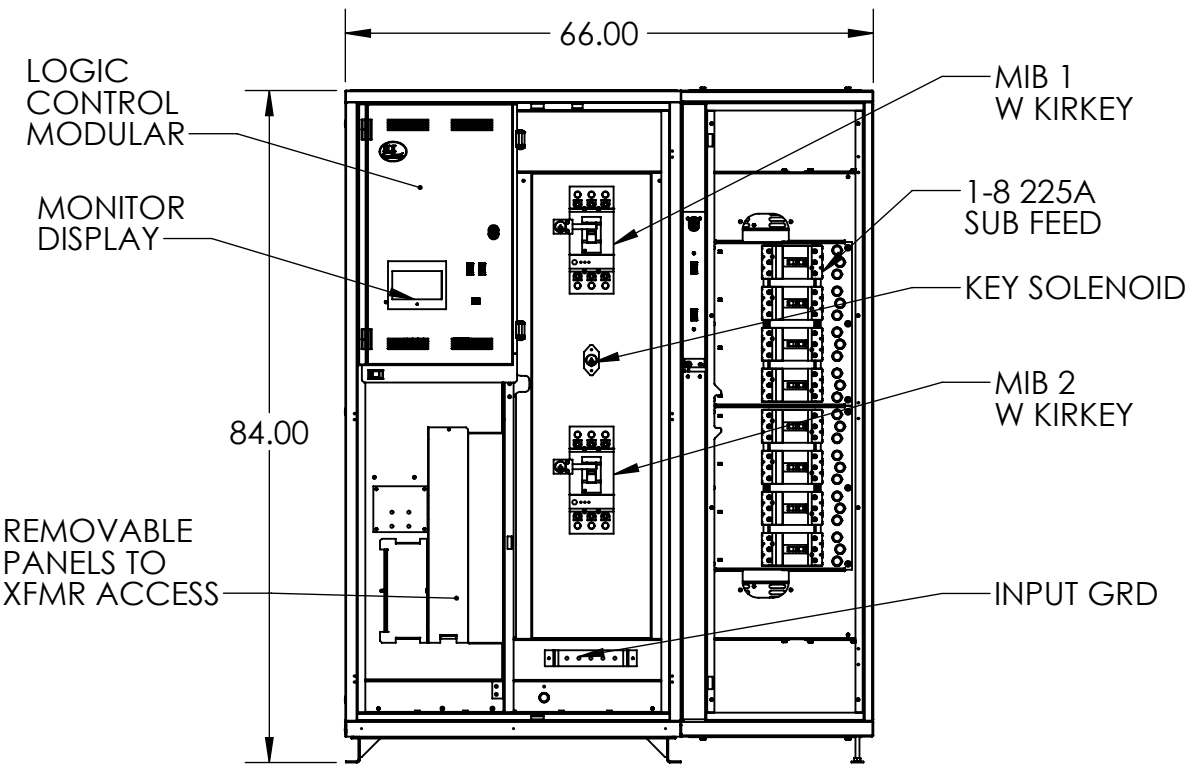
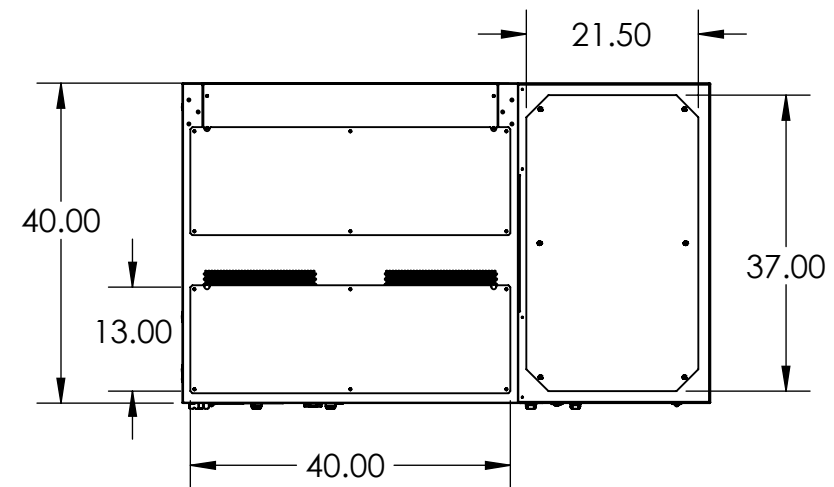

DOORS AND PANELS REMOVED

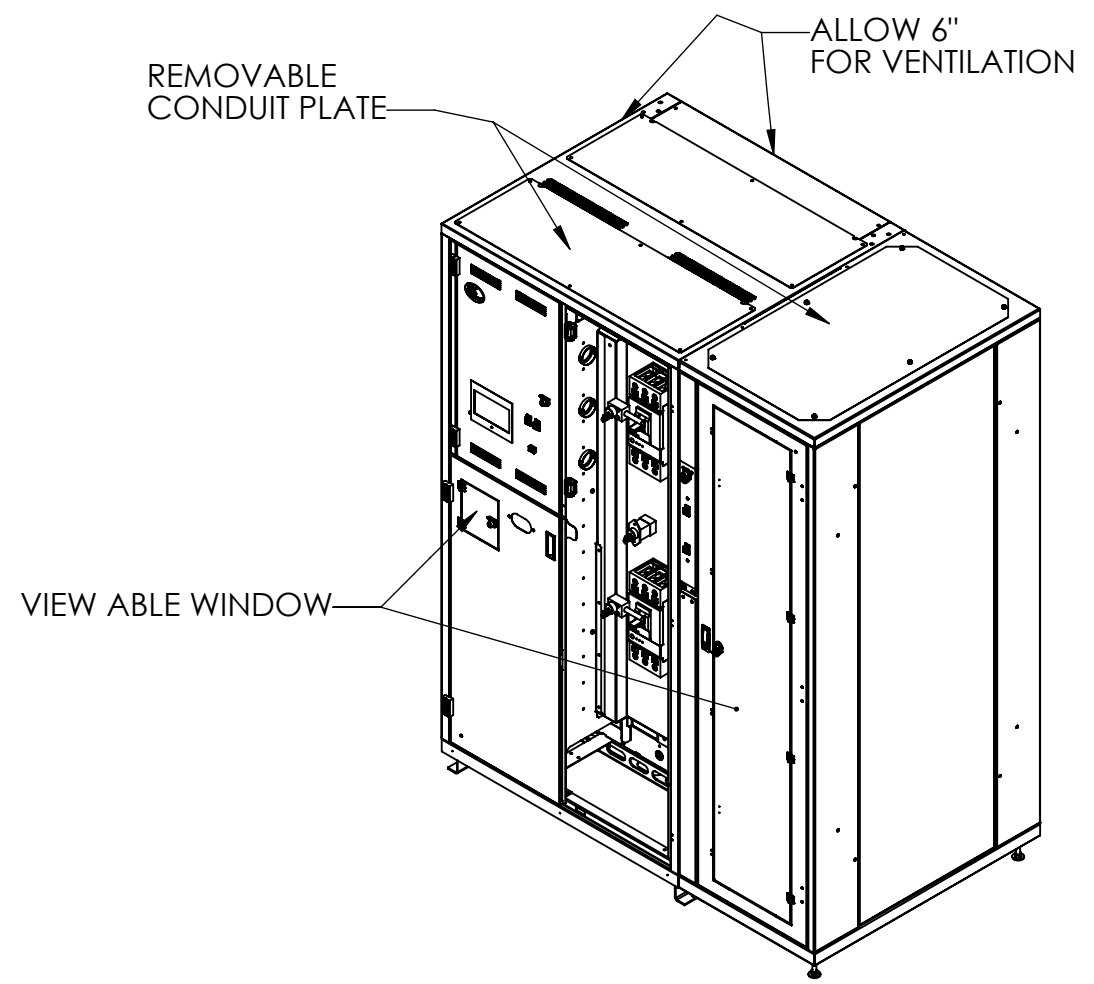

GENERAL SPECIFIED

CABINET CHARACTERISTIC:
 ENCLOSURE : NEMA 1
 LOCATION : INDOOR
 MECHANICAL: MATERIAL: STEEL
 FINISH: EXTERIOR PANELS: PEARL WHITE OR CARBIDE BLACK
 WEIGHT : 3200 # ESTIMATE
 FRONT ACCESS FOR INSTALLATION AND MAINTENANCE
 ALL OPERATOR CONTROLS ARE FRONT ACCESS WITHOUT EXPOSE TO LIVE PARTS

- MIB 1 W KIRKEY
- 1-8 225A SUB FEED
- KEY SOLENOID
- MIB 2 W KIRKEY
- INPUT GRD

- LOGIC CONTROL MODULAR
- MONITOR DISPLAY
- REMOVABLE PANELS TO XFMR ACCESS

UNLESS OTHERWISE SPECIFIED:
 DIMENSIONS ARE IN INCHES
 [] IN MILLIMETER
 ANGULAR: $\pm 0.5^\circ$ BEND $\pm 1^\circ$
 TWO PLACE DECIMAL ± 0.02
 THREE PLACE DECIMAL ± 0.005

THIS DRAWING CONTAINS
 CONFIDENTIAL & PROPRIETARY
 INFORMATION AND SHALL NOT
 BE DISCLOSED OR COPIED
 WITHOUT THE EXPRESSED,
 WRITTEN PERMISSION OF
 SMITHS POWER



THIRD ANGLE PROJECTION		DO NOT SCALE DRAWING	
APPROVALS		DATE	
DRAWN	IS	9/2/16	
CHECKED	LJN	9/2/16	
ENG. APPR.			

TITLE: MDP, 300 KVA, (5) JFRAME SF		
SIZE B	DWG. NO. PDU20979	REV
PART NO.		SHEET 1 OF 1

8 7 6 5 4 3 2 1