

8 7 6 5 4 3 2 1

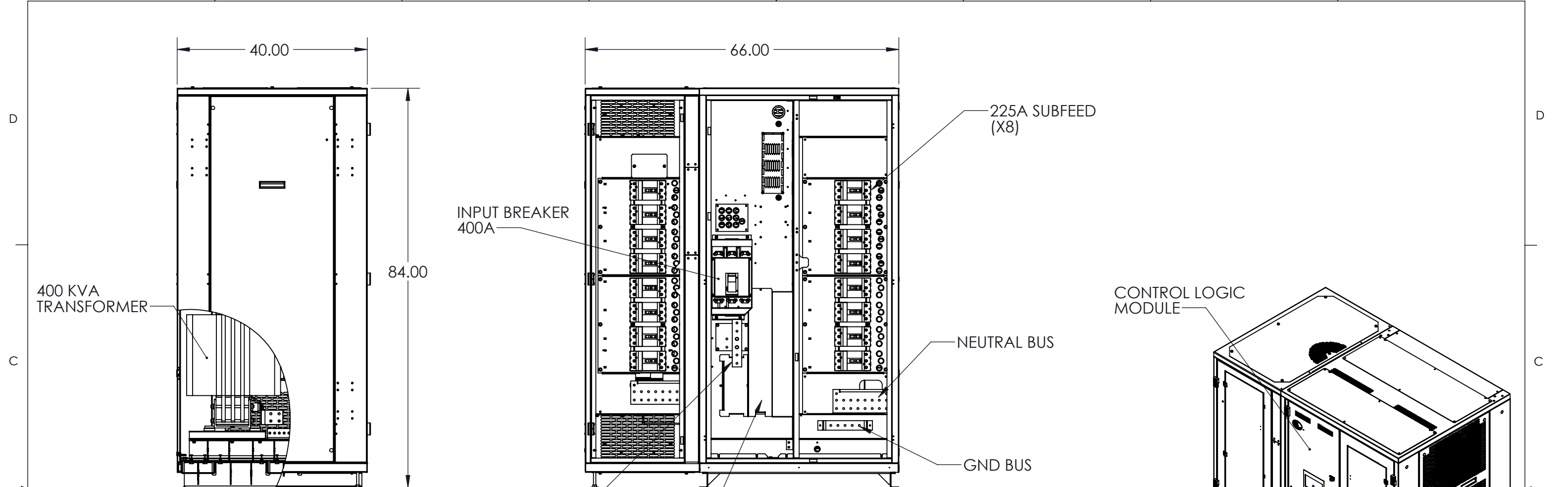

INPUT BREAKER 400A
 INPUT GND BUS
 FRONT TRANSFORMER ACCESS REMOVABLE PANEL
 NEUTRAL BUS
 GND BUS

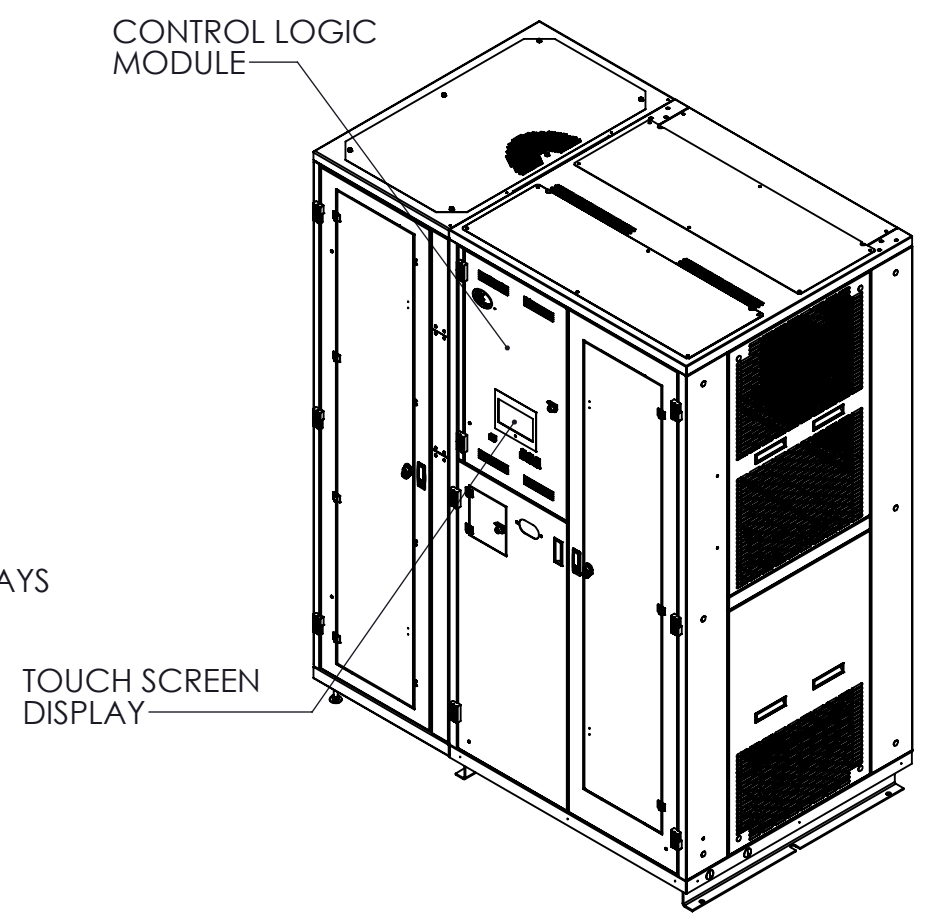

CONTROL LOGIC MODULE
 TOUCH SCREEN DISPLAY
 REMOVABLE TRAYS

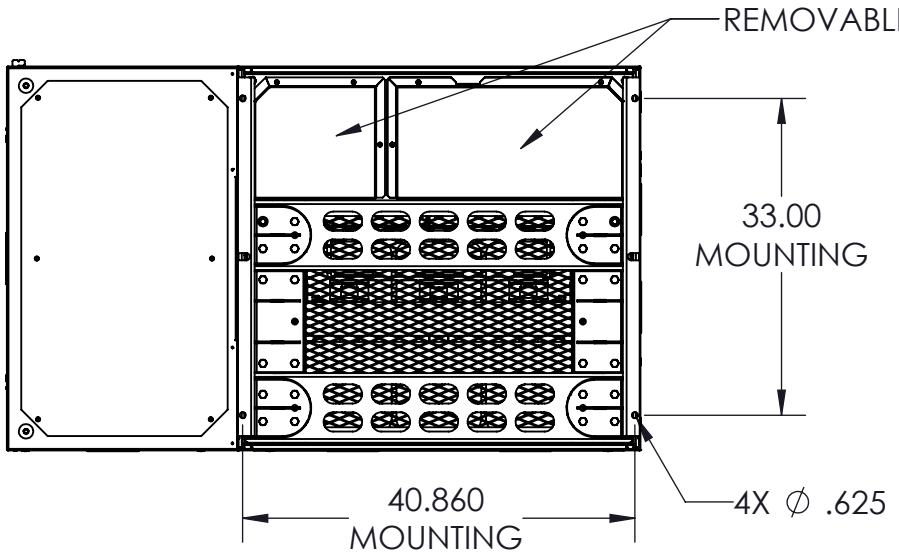

33.00 MOUNTING
 40.860 MOUNTING
 4X Ø .625

GENERAL SPECIFIED

CABINET CHARACTERISTIC:
 ENCLOSURE : NEMA 1
 LOCATION : INDOOR

MECHANICAL:
 MOUNTING: BOLT TO CONCRETE FLOOR OR FLOOR STAND
 MATERIAL: STEEL
 WEIGHT : 3000 LBS. APPROX.

ELECTRICAL:
 INPUT #1: 600 VAC MAX 3PH W/GND @ 60 HZ, 700A (MAX) (3 EA. # 3/0-500 MCM)
 OUTPUT SUBFEED #1 - #16: 3-POLE, 600VAC MAX, 225A, 100% CONTINUOUS LOAD (3/0 - 350 MCM)

ENVIRONMENTAL:
 OPERATING AMBIENT TEMPERATURE 0 °C TO 40 °C (32 ° F TO 104 ° F)
 RELATIVE HUMIDITY: 0% TO 95 % NON-CONDENSING
 ALTITUDE: 10,000 FT MAX

UNLESS OTHERWISE SPECIFIED:
 DIMENSIONS ARE IN INCHES
 [] IN MILLIMETER
 ANGULAR: ±0.5° BEND ±1°
 TWO PLACE DECIMAL ±0.02
 THREE PLACE DECIMAL ±0.005

THIS DRAWING CONTAINS
 CONFIDENTIAL & PROPRIETARY
 INFORMATION AND SHALL NOT
 BE DISCLOSED OR COPIED
 WITHOUT THE EXPRESSED,
 WRITTEN PERMISSION OF
 SMITHS POWER



THIRD ANGLE PROJECTION		DO NOT SCALE DRAWING	
APPROVALS		DATE	
DRAWN			
CHECKED			
ENG. APPR.			

TITLE: (8) 225A SUBFEED, 400KVA PP2		
SIZE B	DWG. NO. PDU56432	REV A
PART NO.		SHEET 1 OF 1

8 7 6 5 4 3 2 1