

400KVA
TRANSFORMER

CASTER 1200 LBS
MAX LOAD
(X4)

MOUNTING BRACKET

INPUT BREAKER
700A

INPUT GND BUS

225A 100% LSI TRIP
(X8)

NEUTRAL BUS

GND BUS

CONTROL LOGIC MODULE

TOUCH SCREEN
DISPLAY

GENERAL SPECIFIED

CABINET CHARACTERISTIC:
ENCLOSURE : NEMA 1
LOCATION : INDOOR

MECHANICAL:
MOUNTING: WALL OR H FRAME, 6X ϕ .44 " PRE PUNCH HOLES
MATERIAL: STEEL
FINISH: EXTERIOR PANELS: PEARL WHITE - PHTI-60016
WEIGHT : 375 LBS. APPROX.

ELECTRICAL:
INPUT #1: 600 VAC MAX 3PH W/GND @ 60 HZ, 700A (MAX) (3 EA. # 3/0-5000 MCM)
OUTPUT SUBFEED #1 - #8: 3-POLE, 600VAC MAX, 225A, 100% CONTINUOUS LOAD
(3/0 - 350 MCM)

ENVIROMENTAL:
OPERATING AMBIENT TEMPERATURE 0 °C TO 40 °C (32 ° F TO 104 °F)
RELATIVE HUMIDITY: 0% TO 95 % NON-CONDENSING
ALTITUDE: 10,000 FT MAX

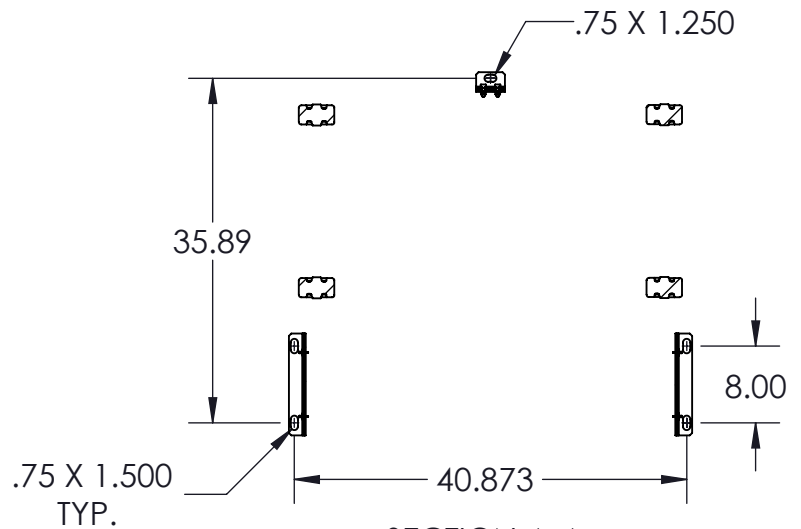

SECTION A-A
SCALE 1 : 20

UNLESS OTHERWISE SPECIFIED:
DIMENSIONS ARE IN INCHES
[] IN MILLIMETER
ANGULAR: $\pm 0.5^\circ$ BEND $\pm 1^\circ$
TWO PLACE DECIMAL ± 0.02
THREE PLACE DECIMAL ± 0.005

THIS DRAWING CONTAINS
CONFIDENTIAL & PROPRIETARY
INFORMATION AND SHALL NOT
BE DISCLOSED OR COPIED
WITHOUT THE EXPRESSED,
WRITTEN PERMISSION OF
SMITHS POWER



THIRD ANGLE PROJECTION		DO NOT SCALE DRAWING	
APPROVALS		DATE	
DRAWN			
CHECKED			
ENG. APPR.			

TITLE: (8) 225A SUBFEED, 400KVA PP2		
SIZE B	DWG. NO. PDU56185	REV A
PART NO.		SHEET 1 OF 1