

8 7 6 5 4 3 2 1

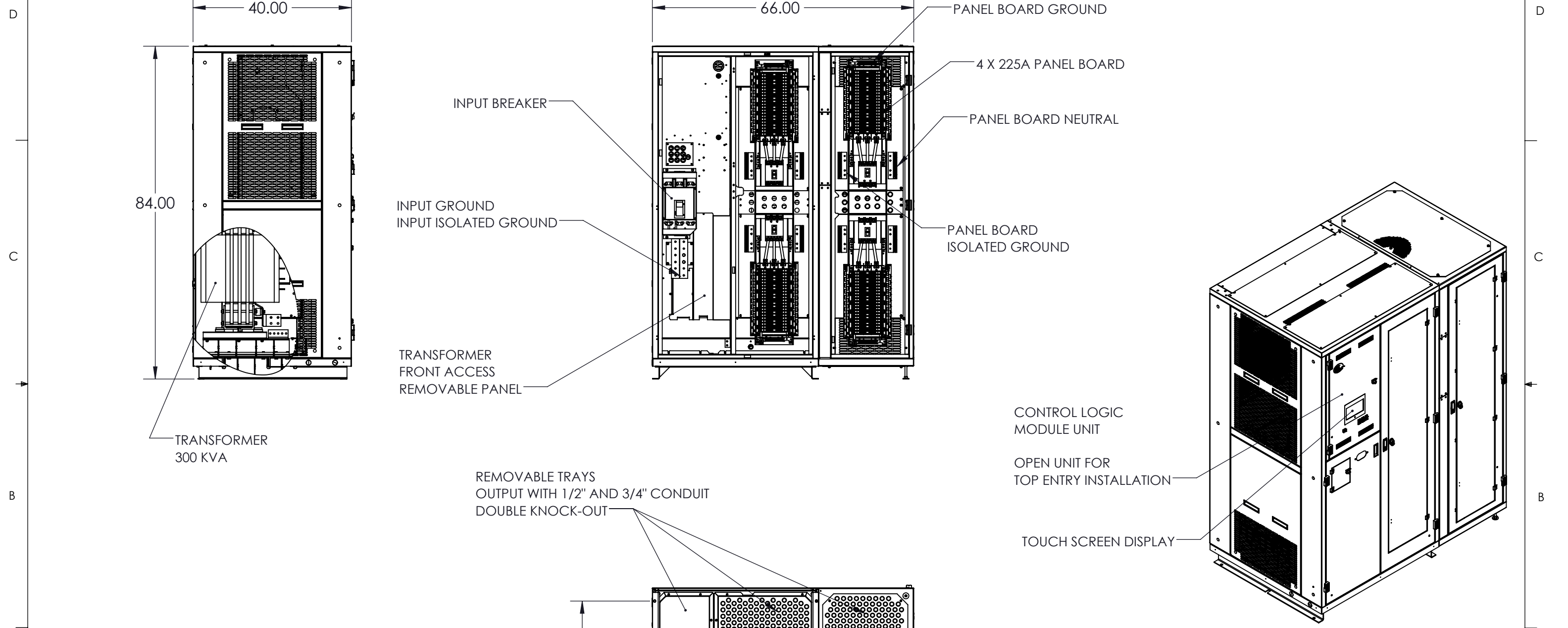

GENERAL SPECIFIED

CABINET CHARACTERISTIC:
 ENCLOSURE : NEMA 1
 LOCATION : INDOOR

MECHANICAL:
 MOUNTING: BOLT DOWN ON CONCRETE OR FLOOR STAND
 MATERIAL: STEEL
 WEIGHT : 3500 LBS. APPROX.

ELECTRICAL:
 INPUT #1: 480 VAC 3PH-4W W/GND @ 60 HZ, 500A MAX.
 OUTPUT PB 1 to 4: 42 POLE, BOLT ON CIRCUIT BREAKER (60 A MAX)

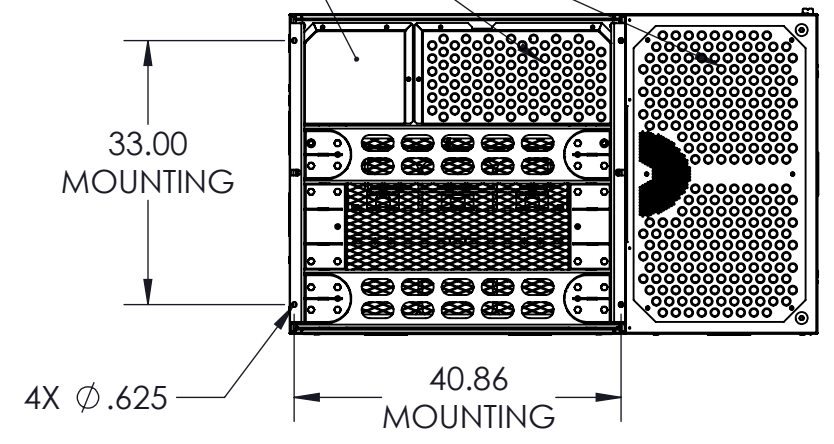

UNLESS OTHERWISE SPECIFIED:
 DIMENSIONS ARE IN INCHES
 [] IN MILLIMETER
 ANGULAR: $\pm 0.5^\circ$ BEND $\pm 1^\circ$
 TWO PLACE DECIMAL ± 0.02
 THREE PLACE DECIMAL ± 0.005

THIS DRAWING CONTAINS
 CONFIDENTIAL & PROPRIETARY
 INFORMATION AND SHALL NOT
 BE DISCLOSED OR COPIED
 WITHOUT THE EXPRESSED,
 WRITTEN PERMISSION OF
 SMITHS POWER



THIRD ANGLE PROJECTION		DO NOT SCALE DRAWING	
APPROVALS		DATE	
DRAWN	IK	8/18/16	
CHECKED	LJN	8/18/16	
ENG. APPR.			

TITLE: PP2 OUTLINE 300 KVA, (4) 42P SQD NQ PANELBOARD		
SIZE B	DWG. NO. PDU56485	REV A
PART NO.		SHEET 1 OF 1

8 7 6 5 4 3 2 1