

GENERAL SPECIFIED

CABINET CHARACTERISTIC:

ENCLOSURE : NEMA 1
 LOCATION : INDOOR
MECHANICAL:
 MATERIAL: STEEL
 FINISH: EXTERIOR PANELS: PEARL WHITE - PHTI-60016
 TRANSFORMER HEAT GENERATE 8 KW
 WEIGHT: APPROX. 3000LBS

FRONT ACCESS FOR INSTALLATION AND MAINTENANCE
 ALL OPERATOR CONTROL ARE FRONT ACCESS WITHOUT EXPOSE TO LIVE PARTS
 MINIMUM 6" FOR SIDE AND REAR FOR VENTILATION

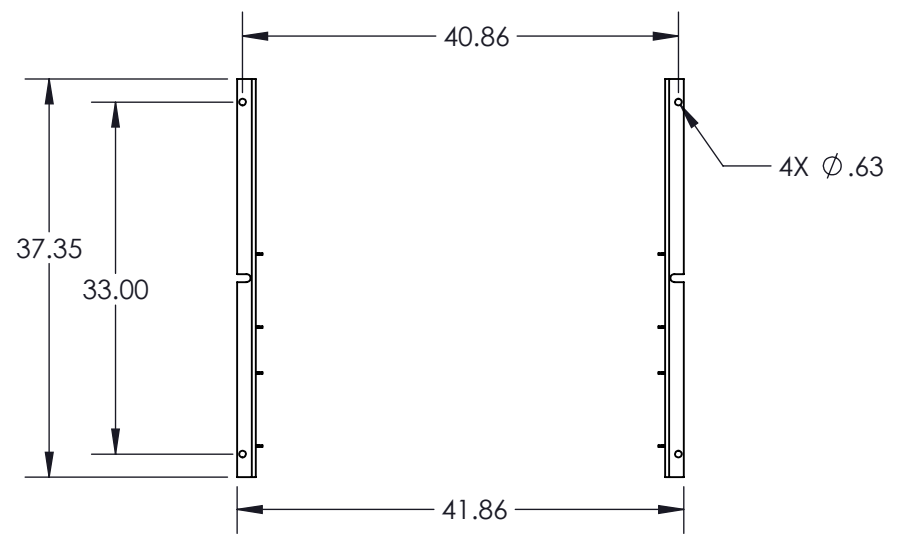

SECTION A-A
 SCALE 1 : 18

THIS DRAWING CONTAINS
 CONFIDENTIAL & PROPRIETARY
 INFORMATION AND SHALL NOT
 BE DISCLOSED OR COPIED
 WITHOUT THE EXPRESSED,
 WRITTEN PERMISSION OF
 POWER DISTRIBUTION, INC.



APPROVALS		DATE
DRAWN	LJN	8/22/16
DESIGNED		
CHECKED		
ENG. APPR.		
MFG. APPR.		

TITLE: OUTLINE PP2 300 KVA, (3) 400A SUB FEED		
SIZE B	DWG. NO. PDU56086	REV A
SCALE: NTS		SHEET 1 OF 2

8 7 6 5 4 3 2 1

D
C
B
A

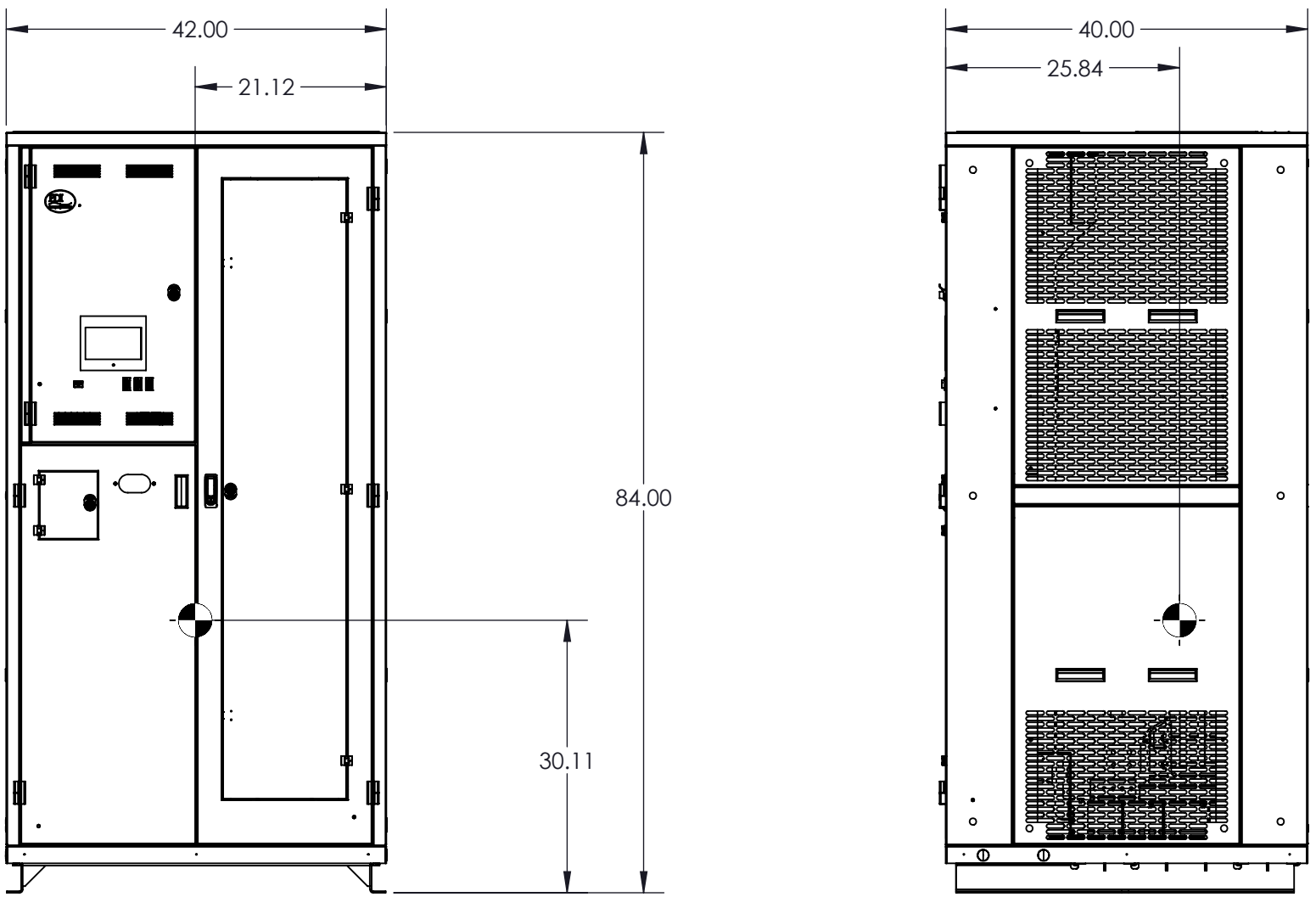

D
C
B
A

CENTER OF MASS

UNIT WEIGHS APPROX. 3000LBS

SIZE B	DWG. NO. PDU56086	REV A
SCALE: NTS		SHEET 2 OF 2

8 7 6 5 4 3 2 1

A B C D E F G H I J K

1
2
3
4
5
6

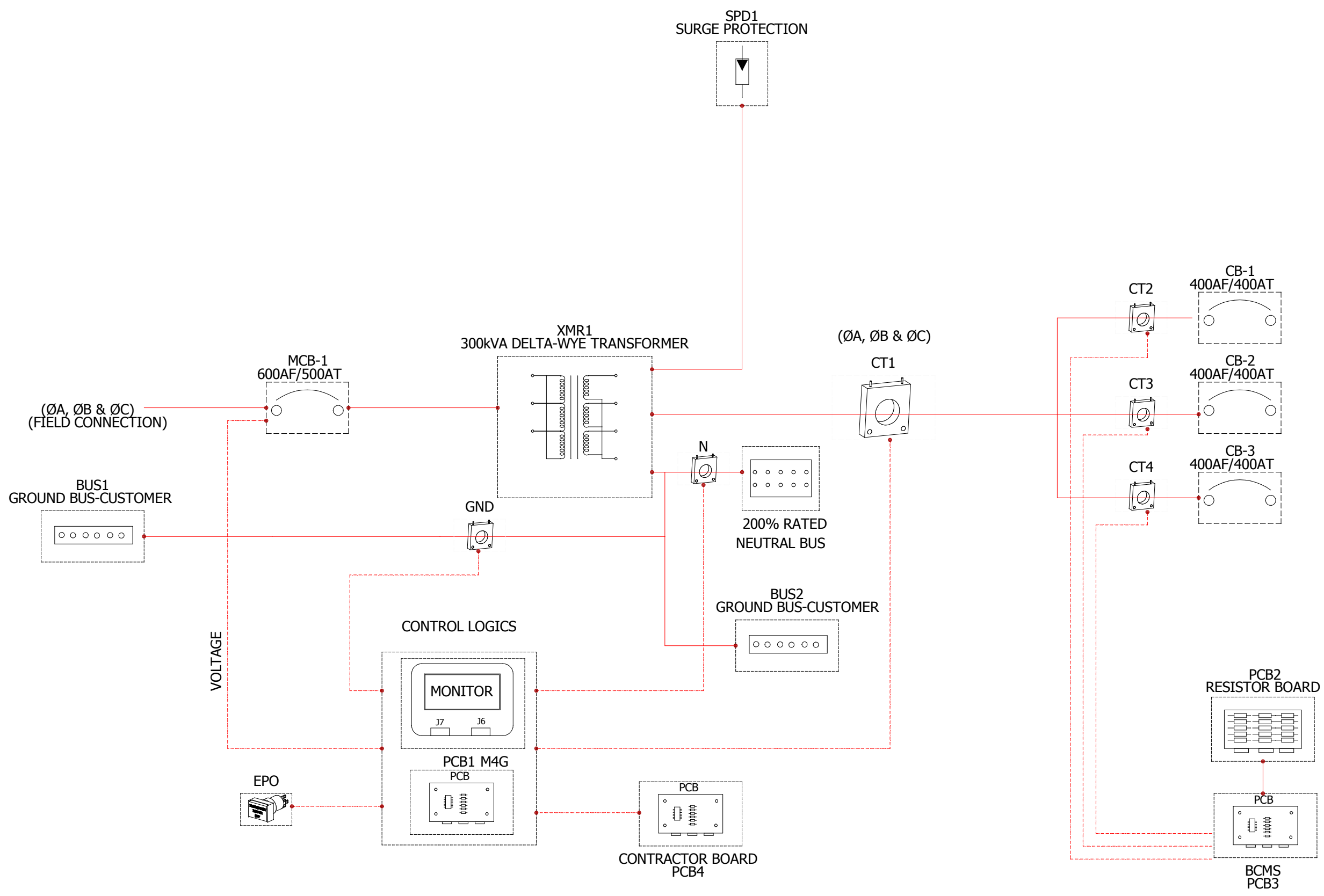

<p>THIS DRAWING CONTAINS CONFIDENTIAL & PROPRIETARY INFORMATION AND SHALL NOT BE DISCLOSED OR COPIED WITHOUT THE EXPRESSED, WRITTEN PERMISSION OF POWER DISTRIBUTION INC.</p> <p>www.pdicorp.com</p>	300 KVA, (3) 400A SUB FEED			REVISION A
	SIZE	B	CREATED: NK 10/7/2016	PAGE
			CHECKED: LN 10/7/2016	
			APPROVED: LN 10/7/2016	01 OF 1
PP2 300KVA(3)400A SUB		DWG NO. PDU56086-O	NAME	DATE