

VIEW WITHOUT DOORS

**VIEW SHOW BOTTOM ENTRY
FOR TOP ENTRY, INPUT GND BUS
AND BREAKER THRU PLATE WILL
SWITCH POSITIONS**

TOP REMOVABLE TRAY
BLANK FOR TOP INPUT AND OUTPUT

DOUBLE KNOCK-OUT 1/2" AND 3/4" CONDUIT
IS AVAILABLE
SPECIFY IN PURCHASE ORDER

CONTROL MODULE
WITH TOUCH SCREEN DISPLAY

SWING OUT MODULE FOR
EASY TOP ENTRY INSTALLATION

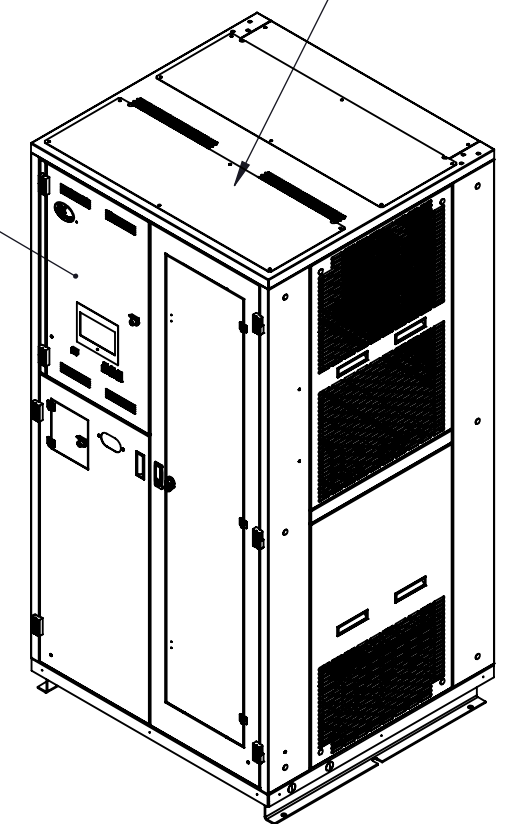

BOTTOM REMOVABLE TRAY
BLANK FOR BOTTOM INPUT

BOTTOM REMOVABLE TRAY
WITH DOUBLE 1/2" AND 3/4"
CONDUIT KNOCK-OUT

33.00
MOUNTING HOLES

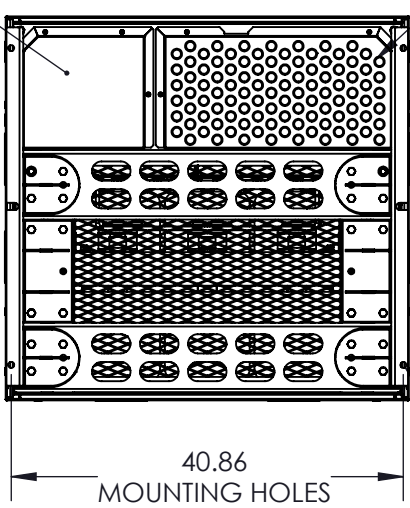

GENERAL SPECIFIED

CABINET CHARACTERISTIC:
ENCLOSURE : NEMA 1
LOCATION : INDOOR
MECHANICAL:
MOUNTING: BOLT ON CONCRETE FLOOR OR FLOOR STAND
MATERIAL: STEEL
FINISH: EXTERIOR PANELS: PEARL WHITE - PHTI-60016
WEIGHT : 3000 LBS. APPROX.
ELECTRICAL:
INPUT #1: 480 VAC 3PH-3W W/GND @ 60 HZ
OUTPUT PB #1: 42 POLE, BOLT ON CIRCUIT BREAKER (100 A MAX)
RECOMMEND: 6" FROM WALL AND SIDE FOR VENTILATION

UNLESS OTHERWISE SPECIFIED:
DIMENSIONS ARE IN INCHES
[] IN MILLIMETER
ANGULAR: ±0.5° BEND ±1°
TWO PLACE DECIMAL ±0.02
THREE PLACE DECIMAL ±0.005

THIS DRAWING CONTAINS
CONFIDENTIAL & PROPRIETARY
INFORMATION AND SHALL NOT
BE DISCLOSED OR COPIED
WITHOUT THE EXPRESSED,
WRITTEN PERMISSION OF
SMITHS POWER



THIRD ANGLE PROJECTION		DO NOT SCALE DRAWING	
APPROVALS		DATE	
DRAWN	ISF	11/17/2016	
CHECKED			
ENG. APPR.			

TITLE: (1) 42-POLE, 277/480VAC, 225A PANEL BOARD OUTPUT 225KVA TRANSFORMER		
SIZE B	DWG. NO. PDU56361	REV A
PART NO.		SHEET 1 OF 1