

8 7 6 5 4 3 2 1

REV.	ECN #	DESCRIPTION	DATE	APPROVED
------	-------	-------------	------	----------

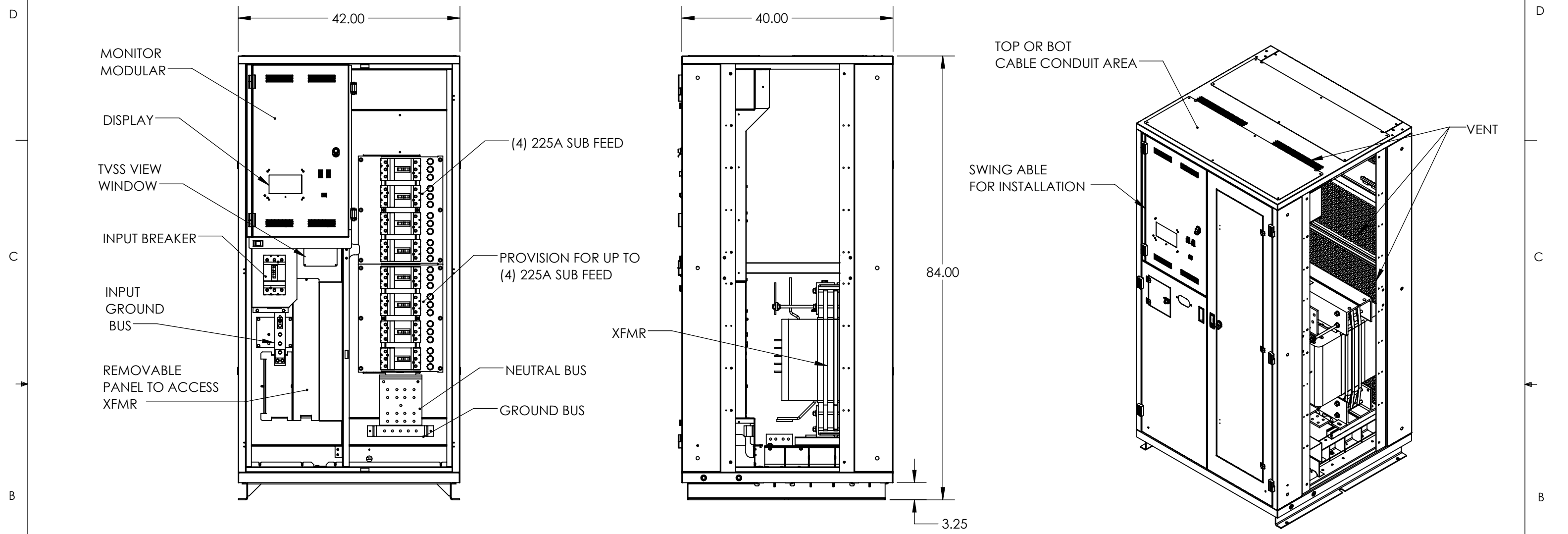

GENERAL SPECIFIED

CABINET CHARACTERISTIC:

ENCLOSURE : NEMA 1
 LOCATION : INDOOR

MECHANICAL:

MATERIAL: STEEL
 FINISH: EXTERIOR PANELS: PEARL WHITE - PHTI-60016 OR CARBIDE BLACK - EBT2C0000
 WEIGHT : 3000 LBS. APPROX.
 TRANSFORMER HEAT GENERATE 8 KW

FRONT ACCESS FOR INSTALLATION AND MAINTENANCE
 ALL OPERATOR CONTROL ARE FRONT ACCESS WITHOUT EXPOSE TO LIVE PARTS
 MINIMUM 6" FOR SIDE AND REAR FOR VENTILATION

THIS DRAWING CONTAINS CONFIDENTIAL & PROPRIETARY INFORMATION AND SHALL NOT BE DISCLOSED OR COPIED WITHOUT THE EXPRESSED, WRITTEN PERMISSION OF POWER DISTRIBUTION, INC.



THIRD ANGLE PROJECTION	
APPROVALS	DATE
DRAWN LJN	8/22/16
DESIGNED	
CHECKED	
ENG. APPR.	
MFG. APPR.	

TITLE: OUTLINE PP2 150-400 KVA, (1-8) 225A SUB FEED		
SIZE B	DWG. NO. PDU20073	REV
SCALE: NTS		SHEET 1 OF 1

8 7 6 5 4 3 2 1