

Eaton® PDI Modular Compact Remote Power Panel

Installation and Operation Manual





Dear Customer,

On behalf of everyone at Eaton, we thank you for partnering with us, and trusting us to maintain your business continuity and preventing downtime at your facility.

Our suite of backup power, power distribution and power management products are designed to protect you from a host of threats including power outages, surges, lightning strikes, and enable you to monitor and control your power infrastructure.

We trust that your Eaton Uninterruptible Power Supply system and Accessory Products, will deliver high quality, reliable backup power for your business, and we are committed to your success.

Please read this Installation and Operation Manual, which details the installation, and operation processes for your uninterruptible power supply system.

Thank you for choosing Eaton!

Eaton reserves the right to change specifications without prior notice. Eaton is a registered trademark of Eaton. PDI, JCOMM, Quad-Wye, ToughRail Technology, and WaveStar are registered trademarks of Power Distribution Inc. All other trademarks are held by their respective owners. All other trademarks are property of their respective companies.

©Copyright 2023 Eaton, Raleigh, NC, USA. All rights reserved. No part of this document may be reproduced in any way without the express written approval of Eaton.

Table of Contents

1 Safety	1
2 Installation Planning	3
2.1 Modular Compact RPP Summary	3
2.2 Modular Compact RPP Internal Feature Configurations	4
2.3 Modular Compact RPP Specification	4
2.4 Installing Modular Compact RPP Cabinets	5
2.5 External Cabinet Configurations	5
2.5.1 Single Unit	5
2.5.2 Cluster Configurations	6
2.6 Modular Compact RPP Electrical Configurations	9
3 Installation	11
3.1 Receiving and Unpacking Unit(s)	11
3.2 Move the Unit to the Installation Location	11
3.3 Installing Modular Compact RPP Cabinets	12
3.4 Power Wiring	13
3.4.1 Cable Entry/Exit	13
3.4.2 Input Power Connections	14
3.4.3 Output Power Connections	15
4 Initial Startup	17
4.1 Pre-Startup Inspection	17
4.2 Startup	17
5 Operating Procedures	19
5.1 Initial System Startup	19
5.2 Normal System Startup	19
5.3 Normal Shutdown	19
5.4 Mission Critical Modular Compact RPP Dual Input Transfer Procedures	19
5.4.1 Normal Operation	20
5.4.2 Transfer from Primary Source to Alternate Source	20
5.4.3 Transfer from Primary Source to Alternate Source	21
6 Monitoring	23
6.1 BCMS	23
6.2 Color Monitor and Protocols	23
6.3 Customer Network Connections	24
6.3.1 Modbus Connections	24
6.3.2 Ethernet Upstream Cables	24
6.4 Networking Modular Compact RPPs Together	24
6.5 Modbus Addressing	27

Table of Contents

- 6.6 Network Connections Details 27
 - 6.6.1 Color Monitor Network Connections 27
 - 6.6.2 Modbus RTU Ports..... 28
 - 6.6.3 Modbus RTU 2-Wire vs. 4-Wire Configuration 29
 - 6.6.4 Modbus RTU Upstream Cable Specification 29
 - 6.6.5 Modbus RTU Cable Biasing and Termination 30
- 7 Resources 31**
 - 7.1 Bibliography 31
 - 7.2 Getting Help 31
 - 7.3 Warranty and End User License Agreement 32
 - 7.4 Equipment Registration 32

List of Figures

Figure 1.	Modular Compact RPP Sections with Features Summary	4
Figure 2.	Single Modular Compact RPP Outline Drawing	6
Figure 3.	Modular Compact RPP Side-by-Side Configurations	7
Figure 4.	Back-to-Back Cluster	8
Figure 5.	Back-to-Back with Sides Clusters	9
Figure 6.	Modular Compact RPP Electrical Configurations with Square D NQ Panelboards	10
Figure 7.	Shipping: Bolt and Wood Screw Locations	13
Figure 8.	Top and Bottom Cable Entry/Exit	14
Figure 9.	Modular Compact RPP Component Layouts with 42-Pole and 84-Pole Panelboards	15
Figure 10.	Mission Critical Transfer Controls	20
Figure 11.	Modbus Terminal Block in Display/Control Compartment	24
Figure 12.	Modbus Wiring in a Modular Cluster	25
Figure 13.	BCMS PCB Modbus Connection in Display/Control Section	26
Figure 14.	Modbus Addressing	27
Figure 15.	Color Monitor Backpanel Network Connections	28

List of Figures

List of Tables

Table 1.	Modular Compact RPP Location Planning Information	4
Table 2.	Pin-Out for Modbus Headers	29

List of Tables

Chapter 1 Safety

Please pay special attention to the use of “Danger” symbols throughout this manual indicating electrical or other safety hazards. Following these safety instructions is extremely important to avoid possible injury or death.



This symbol is used throughout this manual to indicate the presence of high voltages, representing a hazard for electric shock, burn or explosion. Follow the instructions carefully to avoid serious or fatal injury.

Follow safe electrical work practices:

- Electrical equipment should be installed, operated, serviced, and maintained only by qualified personnel and in accordance with all local safety codes. Power Distribution, Inc. assumes no responsibility for any consequences arising out of the use of this manual. This document should not be viewed as sufficient by otherwise non-qualified personnel to operate, service, or maintain the equipment discussed.
- Disconnect and lock-out all power supplying equipment before working on or installing Modular Compact Remote Power Panel components. Use a properly rated voltage sensing device to confirm power is OFF.
- Electrical equipment should be installed, operated, serviced, and maintained only by qualified personnel and in accordance with all local safety codes. Power Distribution, Inc. assumes no responsibility for any consequences arising out of the use of this manual. This document should not be viewed as sufficient by otherwise non-qualified personnel to operate, service, or maintain the equipment discussed.
- Read, understand, and follow the instructions before installing this product.
- Install device in an appropriate electrical enclosure per local regulations.
- ESD sensitive equipment. Ground yourself, discharge any static charge and ensure that the device is effectively grounded before handling the unit.

An installed Modular Compact Remote Power Panel must be securely fastened to a leveled floor or a plumbed wall.

Chapter 2 Installation Planning

2.1 Modular Compact RPP Summary

The Eaton® PDI Modular Compact Remote Power Panel (RPP) is a versatile RPP with a small footprint:

- Two units can fit on a standard 24" x 24" floor tile.
- Any unit can be floor mounted or wall mounted.
- All units are front-access only for normal maintenance.
- Cabinets can be installed together in various combinations, as single units or in side-by-side, back-to-back, or back-to-back-plus-side(s) modular clusters. Internal unit features do not restrict cabinet combinations.
- Internal feature sets can be selected and combined for nearly any RPP application.
- A single WaveStar® Color Monitor can display Branch Circuit Monitoring System (BCMS) power monitoring information for up to seven (7) units with up to fourteen (14) panelboards. An alternative Square D monitoring system is also available.

Certifications are pending through ETL for these standards: UL 60950, UL 891, and CS 22.2.



NOTE

The term PDI in this manual refers to products previous manufactured by Power Distribution, Inc. All service and support for these features are now supplied by Eaton.

2.2 Modular Compact RPP Internal Feature Configurations

Figure 1. Modular Compact RPP Sections with Features Summary

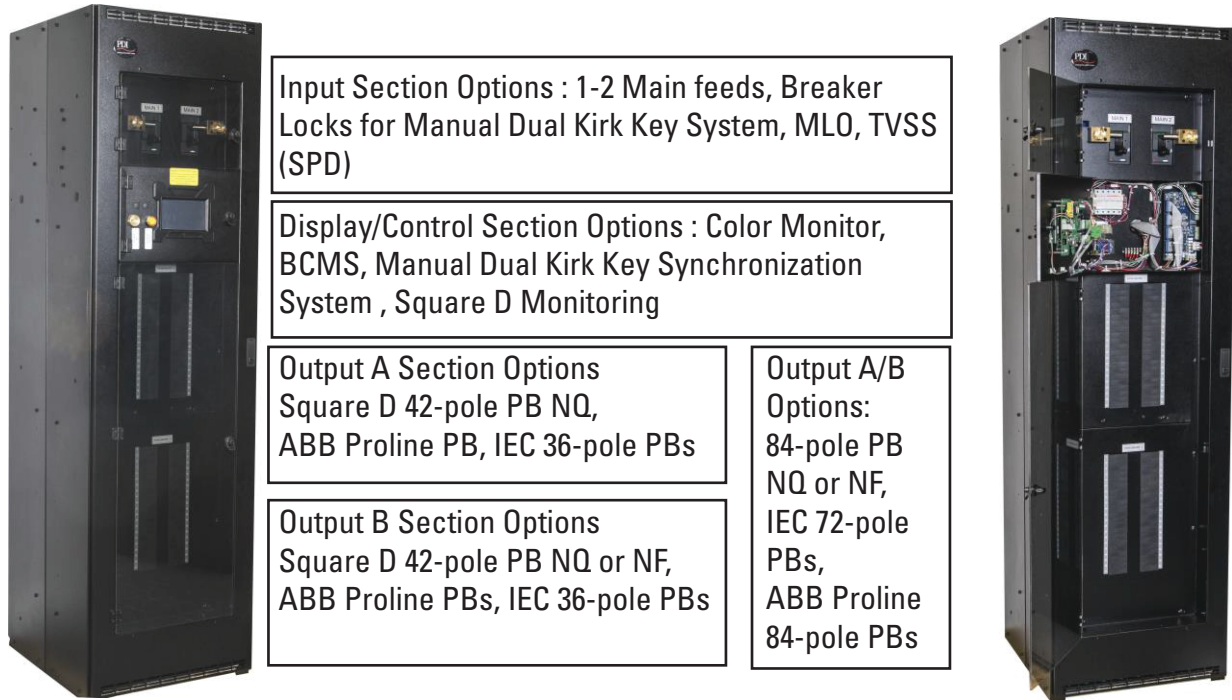

Note: One Modular Compact RPP mission-critical side of a back to back configuration is shown.

Units are manufactured using predefined kits that provide easy combination of features. Configurations are collections of kits laid out in four Modular Compact RPP sections: Input, Display/Control, Output A, and Output B. Internal features and electrical configurations are independent of the way the unit is mounted or clustered with other units.

2.3 Modular Compact RPP Specification

All cabinets have the same dimensions and clearances and similar weights.

Table 1. Modular Compact RPP Location Planning Information

Modular Compact RPP Single Unit Location Specifications		
Dimensions:	23.75" W x 84" H x 12.68" D	
Clearances:		
Front:	36" (service and ventilation)	
Top:	18" (ventilation)	
Underfloor:	12" (for cabling, if bottom entry)	
Weight:	Approximately 225 lbs.; maximum 300 lbs.	Weight varies by unit configuration.

Table 1. Modular Compact RPP Location Planning Information (Continued)

Environmental Requirements:		
Storage temperature	-55°C and +85°C (-67°F to 185°F)	
Operating temperature	0°C to 40°C (32°F to 104°F)	
Relative humidity	0% to 95% non-condensing	
Altitude	Maximum 6,600 ft. (2,000m)	Modular Compact RPP is de-rated if operated above 6,600 ft. (2,000m)

2.4 Installing Modular Compact RPP Cabinets

Modular Compact RPPs can be mounted on floors, on floor tiles with cutouts for bottom cabling, or on floor tile stringers, or wall-mounted regardless of internal configuration; for example, a mission-critical (manual dual) Modular Compact RPP can be floor-mounted or wall-mounted. Units clustered or mounted together can have different internal features and power components.

Units have pre-cut bolt holes for attaching to walls, to other units, and to floors (see [Figure 2](#)) and communications cutouts for running Modbus cables between units.

Optional Floor Mount Kits are recommended for all floor-mount installations.

2.5 External Cabinet Configurations

2.5.1 Single Unit

Single Unit Modular Compact RPP dimensions, mounting bolt holes, and communications cutouts are shown in [Figure 2](#). Single units are not free-standing and must be attached to a wall or other vertical support or be secured to the floor.

Figure 2. Single Modular Compact RPP Outline Drawing

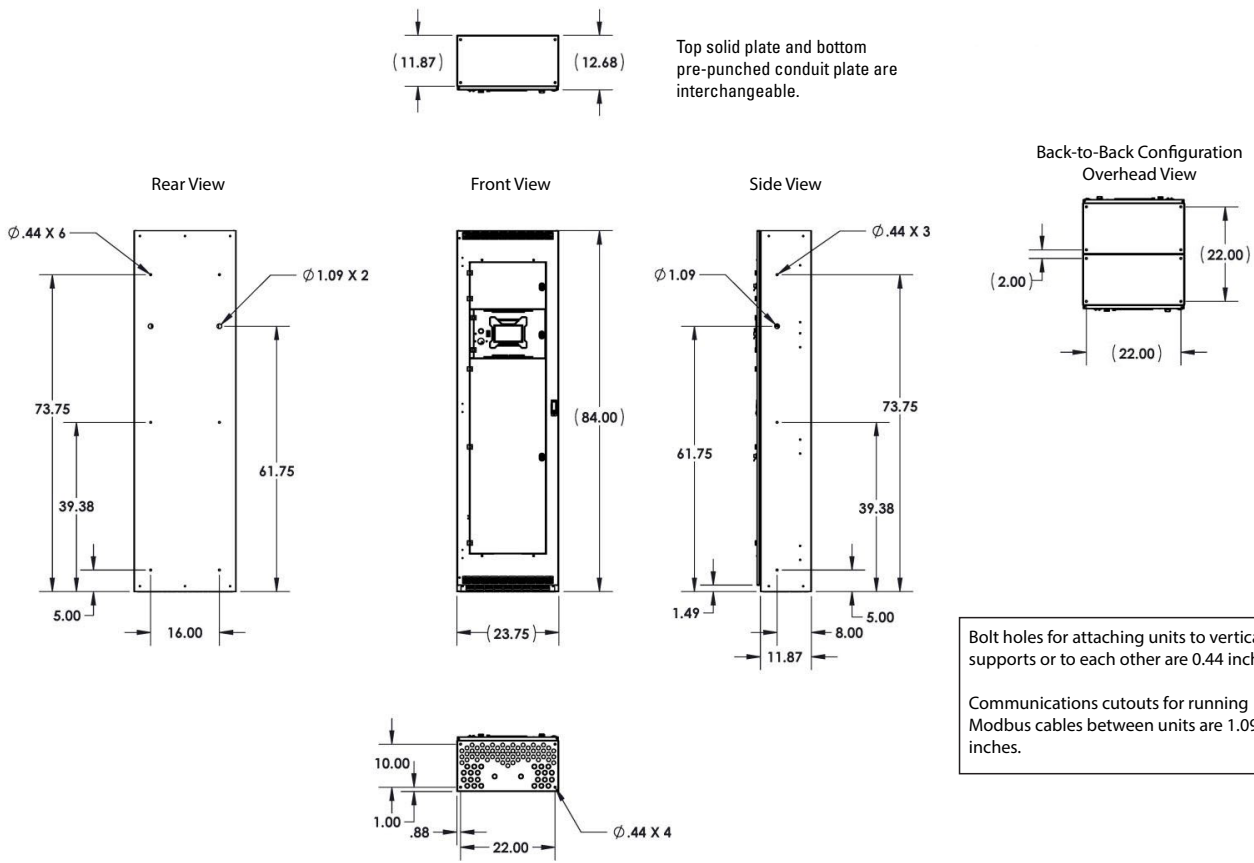

Bolt holes for attaching units to vertical supports or to each other are 0.44 inches.

Communications cutouts for running Modbus cables between units are 1.09 inches.

2.5.2 Cluster Configurations

The Modular Compact RPP can be configured in several cluster configurations that are described in the following illustrations. (See [Figure 3](#), [Figure 4](#), and [Figure 5](#)).

Figure 3. Modular Compact RPP Side-by-Side Configurations

Side-by-side units are not free-standing and must be attached to a wall or other vertical support or secured to the floor.

Bolt units together at sides with bolts included with units.

For securing units to floor, customers provide bolts and other attachment hardware.

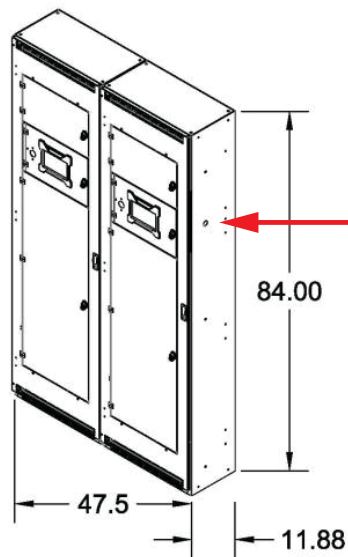

A single Color Monitor can display BCMS information from up to seven (7) units. Modbus cables are run from the Monitor to BCMS PCBs in other units through communication cutouts.

If BCMS PCBs or Monitors are connected between units, remove side communications cutout plugs before bolting units together and replace with included bushings after units are bolted together.

1	2	3	4	...	N
36" Service and ventilation clearance is required in front of all units in side by side configuration. Service and ventilation clearances are the same for each unit in the side by side chain as for individual units.					

Units can be added to the side-by-side configuration on either side, allowing 2, 3, 4, ..., N units.

Figure 4. Back-to-Back Cluster

Back-to-back units are not free standing and must be secured to the floor. For securing units to floor or stringers, customers provide bolts and other attachment hardware.

Bolt units together at backs and sides with bolts included with units.

A single Color Monitor can display BCMS information from up to seven (7) units. Modbus cables are run from the Monitor to BCMS PCBs in other units through communication cutouts.

If BCMS PCBs or Monitors are connected between units, remove side and back communications cutout plugs before units are bolted together and replace with included bushings after they are bolted together. See Figure 2 for back and side mounting locations.

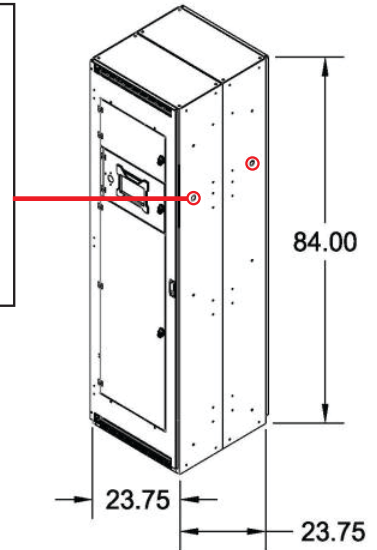

36" Service and ventilation clearance is required in front of all units in side by side configuration.

Service and ventilation clearances are the same for each unit in the side by side chain as for individual units.

1	3	5	7	N-1
2	4	6	8	N

36" service and ventilation clearance in front of all units.

Units can be added to the back-to-back configuration on either side, allowing 2, 4, 6, ..., N units

Figure 5. Back-to-Back with Sides Clusters

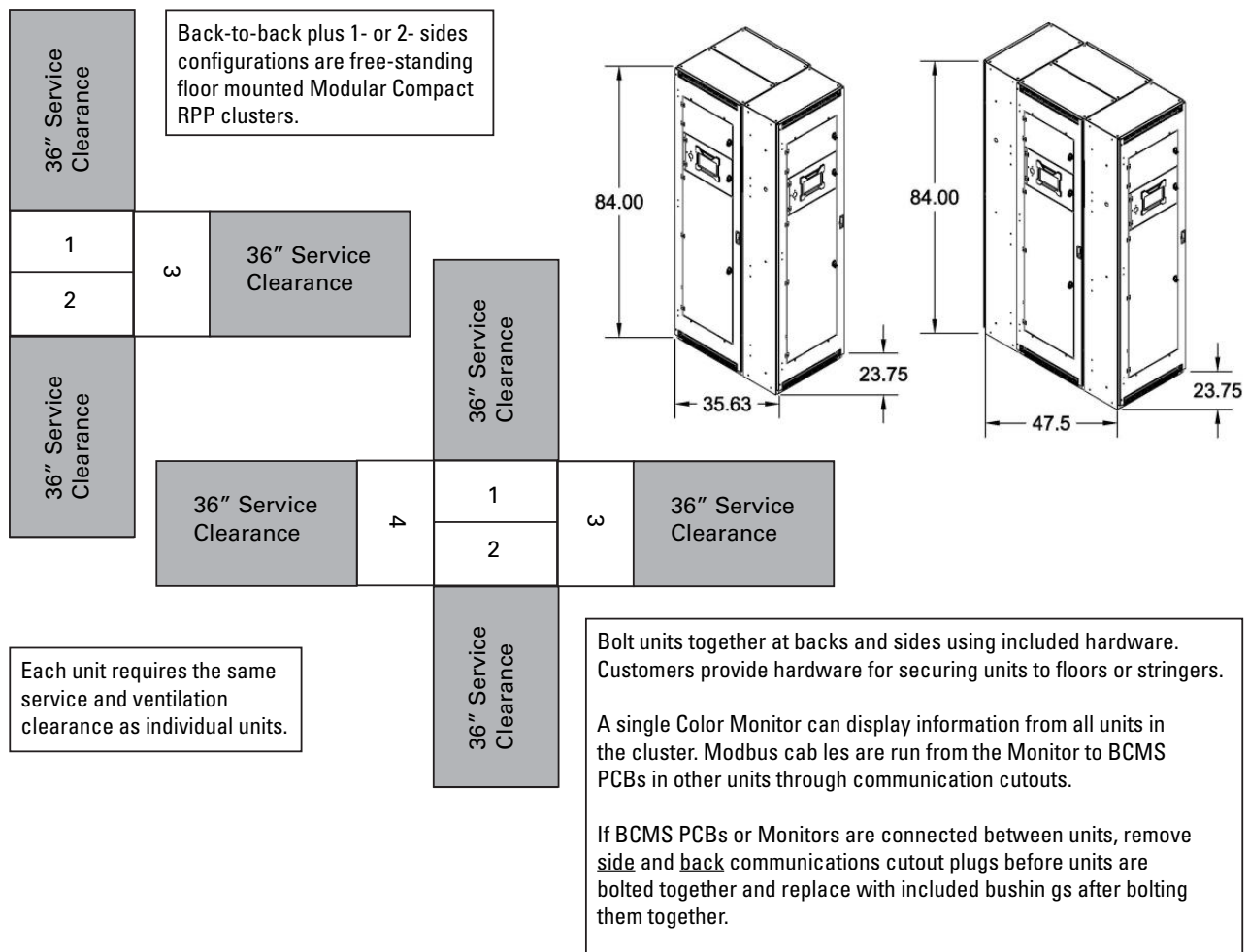

2.6 Modular Compact RPP Electrical Configurations

Modular Compact RPPs can have a variety of power configurations. The configurations below are created using Square D NQ-frame panelboards. Other configurations are available using Square D NF, IEC (SEA), and ABB Proline panelboards. Amperages and voltages vary by configurations.

Consult your Eaton sales representative for configuration options. Eaton Application Engineering can assist you in creating Modular Compact RPP configurations suitable to your applications.

Figure 6. Modular Compact RPP Electrical Configurations with Square D NQ Panelboards

Single Input Source

400A Max. Input
 (1) 400A Circuit Breaker
 (1) NQ Panelboard
 (84) Poles

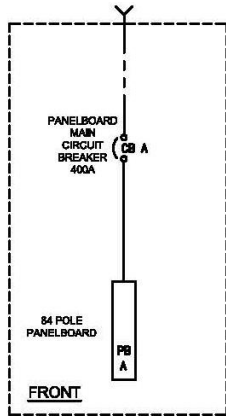

450A Max. Input/
 (2) 225A or 400A
 Circuit Breakers/
 (2) NQ Panelboards
 (42) Poles each

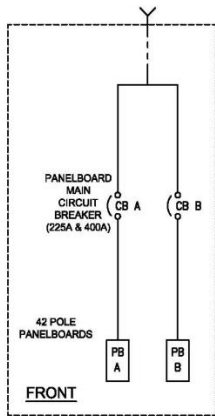

Dual Input Source

400A Max Input per
 Feed/
 (2) NQ Panelboards
 (42) poles each

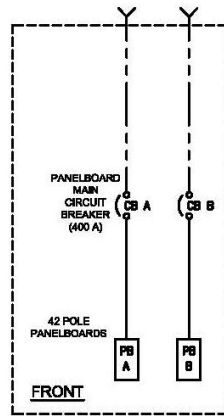

225A Max Input per
 Feed/
 (2) NQ Panelboards
 (42) poles each

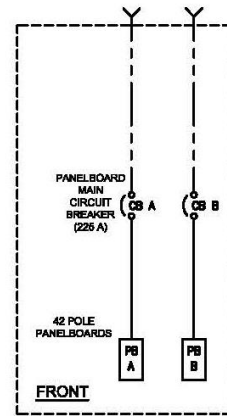

Note 1: External junction box may be required with 400A panelboard circuit breakers in this configuration.

Note 2 : All Modular Compact RPPs with NQ panelboards allow maximum 240VAC

Note 3: When installed on dual input systems, the Color Monitor has a relay to obtain power from the other power source when one source loses power.

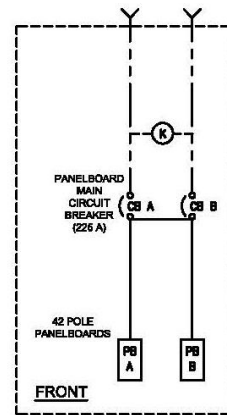
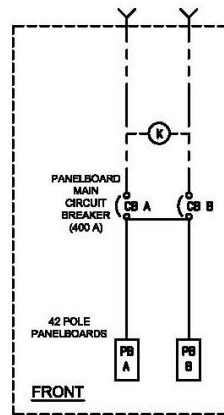

Mission Critical Modular Compact RPPs

Mission Critical Modular Compact RPPs are created by adding the Kirk Key feature to dual input source Modular Compact RPPs

Chapter 3 Installation

⚠ DANGER

- A licensed electrician must install each unit. Startup by a Eaton certified technician is also required to validate the warranty.
 - Severe or fatal injury can result from electrical shock during contact with high voltage conductors, monitoring PCBs, or similar equipment.
 - Disconnect power before drilling holes, attaching cables or conduit, or connecting PDUs to other power distribution equipment.
 - Use Lock Out/Tag Out procedures.
 - Wear suitable personal protective clothing and use protective equipment for performing mechanical and electrical installations.
 - Leave ample space for attaching and routing wires.
-

3.1 Receiving and Unpacking Unit(s)

Modular Compact RPPs are shipped standing upright bolted together in pairs in a back-to-back configuration and attached to pallets with wood screws. When an order has an odd number of units, one unit is shipped standing upright alone. Units can also be shipped singly at customer request.

Upon receiving a Modular Compact RPP pallet and before removing packaging, inspect packaging for visible damage that could affect the Modular Compact RPP(s). If damage is evident notify Eaton and the shipping company (see below).

Carefully cut retaining bands and remove packaging from units, but leave units attached to their pallets. Use care to not puncture or scratch the Modular Compact RPP cabinets with cutting tools.

⚠ CAUTION

Retaining bands are under tension; cut them carefully. Wear eye protection and protective clothing when cutting bands.

After removing packaging, check units again for damage, such as scratches, dents, or cracks.



NOTE

If any damage is evident during unpacking, notify the shipping company and Eaton. Claims should be filed with the shipping company at time of delivery. Damage must be noted on the bill of lading. Failure to properly document damage may void the warranty.

Service Address

3.2 Move the Unit to the Installation Location

Before moving a unit, plan the path from the receiving area to its installation location. Review obstacles, floor weight capacity, corners, etc.

Using a fork lift or pallet jack, move the unit(s) (still secured to their shipping pallet) as close to the installation location as possible over your pre-planned route.

3.3 Installing Modular Compact RPP Cabinets

Most units are shipped bolted together back-to-back with (6) 3/8" bolts. See [Figure 7](#) for bolt locations. If units are to be installed in a back-to-back configuration, leave them bolted together as shipped. Otherwise, remove bolts and nuts and save.

Remove the wood screws attaching the unit(s) to the pallet (see [Figure 7](#)). Make sure units do not tip over.

Slide or lift each unit or bolted-together pair carefully off the pallet onto the correct predetermined location. Individual units can usually be lifted by three or four persons. (Check the weight of your unit(s) given in your submittal package.) Take care not to scratch or damage the unit(s). Units do not have casters and cannot be rolled.

- If mounting on a floor tile, the floor tile cutout should be made in advance.
- If mounting on floor tile stringers, units should be left bolted together in a back-to-back configuration and secured to the stringers. Single units are not stable and must be secured to the floor or wall.
- If mounting to a wall or vertical support, place the unit in the correct position and bolt to the support.

Once each RPP is in its final position, inspect for loose connections or displacement caused by shipping. Ensure all lug connections in ground bus, neutral bus, terminal blocks, etc. are tight and secured.

Check the main input feeder connections at the main breaker to be sure vibration has not loosened the terminal screws. Check the feeders from the load side of the main breaker to the client side of the panels.



IMPORTANT

Customers are responsible for securing units to vertical supports or to the floor.

Refer to installation planning information in Chapter 1 for physical configurations and mounting information.

Bolts for bolting units together in a modular cluster are shipped with units. Customers must supply their own hardware for attaching units to the floor, stringers, or a wall.

Bolt holes and communications cutouts are shipped with plugs installed.

- Remove bolt-hole plugs and replace with provided bolts for when bolting units together. 3/8-in bolts for attaching cabinets to each other are included in the BOM for the unit.
- Communications cutouts allow you to run Modbus cables between units. Replace plugs in communication cutouts with bushings, included in each unit's BOM. For communications cutouts you intend to use, remove plugs before you bolt units together and replace with bushings after bolting them together.

Figure 7. Shipping: Bolt and Wood Screw Locations

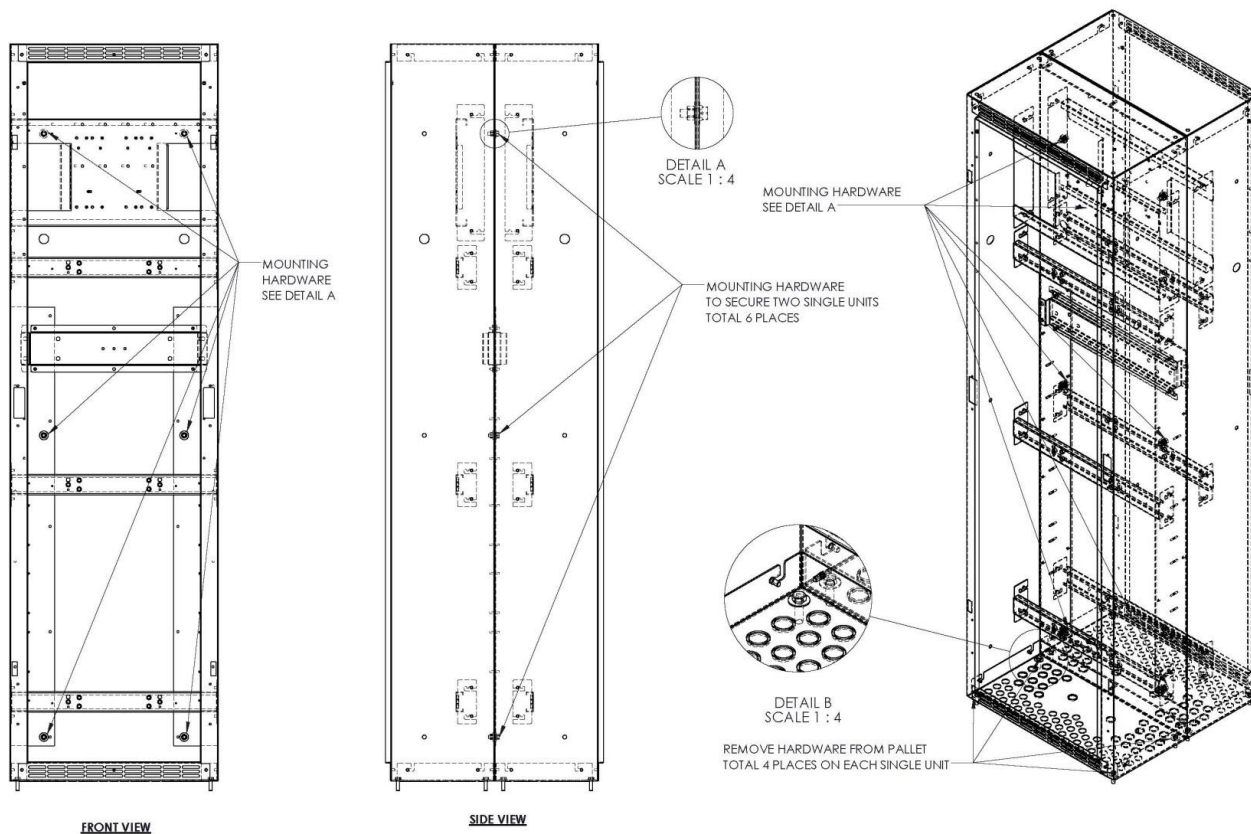

3.4 Power Wiring

Power wiring must comply with NEC and applicable local codes and should be wired by licensed electricians. Reference your submittal package for 1-line drawings specific to your Modular Compact RPP configuration.

3.4.1 Cable Entry/Exit

Cable entry/exit can be from top and/or bottom. Top and bottom plates can be interchanged according to customer cabling requirements.

- The bottom plate has pre-punched knockouts for 1/2" and 3/4" conduit.
 - 60 knockouts for 1/2" conduit (0.88" dia.)
 - 24 double knockouts for 3/4" conduit (1.09 dia.) and 1/2" (0.88" dia.) conduit.
 - 2 x main-feed conduit knockouts; (2) conduit knockouts can be enlarged up to 4".
- The top plate can be used for cutouts.

Open or remove door and execute knockouts for an appropriate number of conduits for intended cable connections.

Figure 8. Top and Bottom Cable Entry/Exit

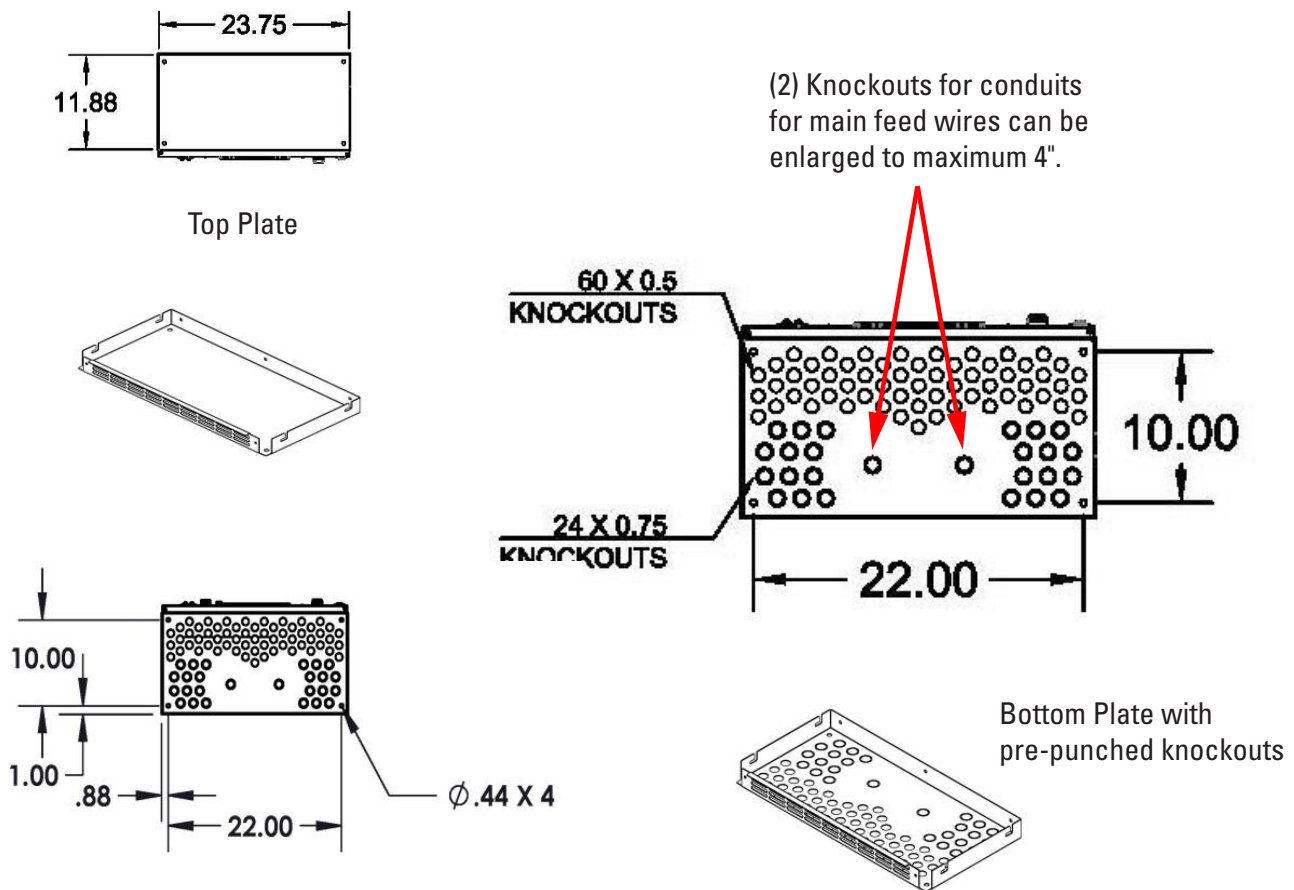

3.4.2 Input Power Connections

[3.4.3 Output Power Connections](#) shows component locations for both 84-pole and 42-pole panelboards and neutral and ground busbar connections.

NOTICE

Power wiring and grounding for this equipment must comply with NEC and local building and electrical codes.

The following provides cable size recommendations:

- Maximum cable sizes: 250 kcmil (MCM) Copper.
- Minimum recommended wire sizes:
 - Main feed input:
 - 225A main feed input: 4/0 wire (rated for 230A @75° C) for each phase .
 - 400A or 450A main feed input: (2) x 4/0 (rated for 450A @75° C), (2) cables per phase.
 - Neutral Busbar, neutrals are sized at 200% phase cables and need double-sized wires:

- 225A (2) x 250 kcmil (MCM) or (2) x 4/0 wire (rated for 230A @75° C)
- 400A: (4) x 250 kcmil (MCM) or (4) x 4/0 wire (rated for 450A @75° C)
- Ground Busbar:
 - 225A: #4 AWG Copper or #2 AWG Aluminum
 - 400A: #3 AWG Copper or #1 AWG Aluminum
- Isolated Ground (optional): Use same wire size as ground.
- Maximum main feed conduit size: (2) conduits, 4-in. maximum, sized for (6)-wires 3P + 2N + 1G (Oversized neutral requires (2) cables.)

Pull input power conduit through knockouts.

Pull cables through units to main breaker lugs. Connect input cables to main circuit breaker lugs and torque lugs to circuit breaker manufacturer’s specification.

Figure 9. Modular Compact RPP Component Layouts with 42-Pole and 84-Pole Panelboards

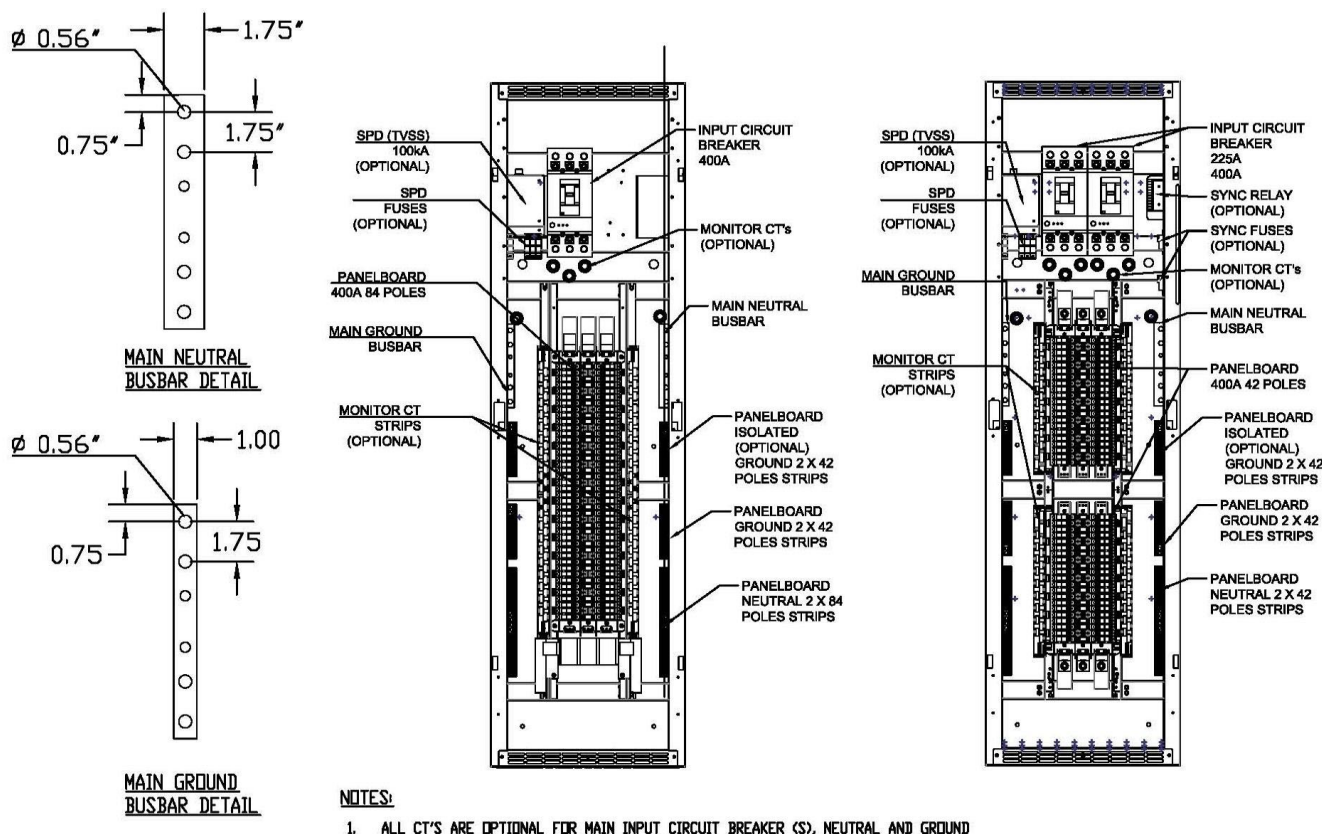

3.4.3 Output Power Connections

Modular Compact RPPs are usually shipped without installed panelboard circuit breakers. Customers are responsible for installing panelboard circuit breakers, running single phase wires through CT strips, and connecting circuit breakers to ground strips, neutral strips, and optional isolated ground strips. Locations are shown on [3.4.3 Output Power Connections](#).

Installation

The output panel boards should have all the output loads balanced at the panelboards in order to place equivalent current wave forms and magnitude on each output. Distributing the 3-pole breakers by ampacity evenly across matched panelboards provides optimum balancing. Single phase loads with high third harmonics should also be evenly balanced across the panelboards. Follow these steps to properly balance circuits.

1. Divide all output into three (3) categories by breaker pole position (1, 2, 3 pole).
2. Subdivide the three categories by breaker size (ampacity).
3. Assign the largest 3-pole breaker to panelboard #1.
4. If there is an even number of the larger 3-pole breakers, assign them evenly between the panel boards. If you are unable to assign them evenly, then assign smaller 3 pole breakers to the panel having fewer breakers.
5. Repeat steps 3 and 4 until all 3-pole breakers are installed.

When determining distribution cable length between panelboard circuit breakers and load equipment, provide sufficient cable length to avoid stress at the connection point between panelboard breakers and distribution cables.

When cabling, do not block access to ground and neutral terminals.

Chapter 4 Initial Startup



Do not perform inspection or startup alone. A second qualified person should be present to provide emergency assistance.

Before applying utility power to the unit, the installing electrician and/or a factory authorized representative should be present to verify that the following steps have been performed properly.

4.1 Pre-Startup Inspection

1. Before applying power to the Modular Compact RPP, inspect wiring and connections. Incoming power to main feeds or MLO lugs should be de-energized and locked out before making this inspection.
2. Inspect wiring, components, and cabinet for damage.
3. Inspect all power connections for tight connections:
 - a. Ensure that all power lug connections in ground bus, neutral bus, and terminal blocks are tight and secured.
 - b. Check main feed terminal screws.
 - c. Check the main feed connections from the load side of the main breaker to the primary side of the panels.
 - d. Torque connections as follows:
 - i. For circuit breakers use manufacturer's recommendations.
 - ii. For other connections, see the torque table on a label on the inside door of the unit.
4. Inspect unit for debris or foreign objects and remove if present.
5. Check that ventilation openings are clean.
6. Check that service and ventilation clearances satisfy code requirements.

4.2 Startup

Before turning on power to the unit:

1. Confirm that the RPP main feed circuit breaker(s) are in the OFF position. (If a breaker has been tripped, reset the breaker to the OFF position.)
2. Lock out input power to the unit (PDU, UPS, or building power).
3. Ensure that all of the RPP output circuit breakers are in the OFF position.
4. Visual voltage label check: Verify that the input voltage to the unit matches the input voltage rating of the unit as identified on the system's legend label affixed to the interior of the front door.

Check input power:

1. Turn ON input power to one main breaker. (Note: if a main breaker trips to OFF when energized, it may indicate a fault in the unit. Contact PDI Service at (800)-225-4838.)
2. Measure and record voltages at input to the main feed(s): A-to-B, B-to-C, C-to-A. Incoming voltage should be + 5% to -10% of the unit's nominal rating.
3. Check for clockwise phase rotation and voltage at the input main feed circuit breaker(s).
4. Repeat steps 1-3 for second main feed breaker if present.

Initial Startup

Check monitoring:

1. The Color Monitor should turn on when power is applied to the main feed from which it receives power. Display panelboard screens for your configuration, but without load, most readings will be zero. **Note:** On dual input systems, the Color Monitor has a relay to obtain power from the second power source, when its primary source loses power or is not enabled.

Sequentially energize loads by turning ON individual panelboards circuit breakers.

Chapter 5 Operating Procedures

5.1 Initial System Startup

Perform initial system startup as described in [Chapter 4 Initial Startup](#),

- after an Modular Compact RPP is first installed, or
- after an Modular Compact RPP has been subsequently relocated, or
- after an Modular Compact RPP has been upgraded or had maintenance performed, or
- after an Modular Compact RPP has been de-energized for a significant period of time.

Perform all checklist steps in [Chapter 4 Initial Startup](#).

5.2 Normal System Startup

Verify that all Modular Compact RPP circuit breakers are turned OFF, both main feeds and panelboard circuit breakers.

Turn ON main feed circuit breaker(s).

- If a main feed circuit breaker has been tripped OFF, first reset the breaker by turning it OFF then ON.
- If a main feed circuit breaker trips OFF when energized, a fault may be present in the unit. Contact Eaton Service at 1-800-843-9433.

Turn ON power to loads by sequentially turning ON panelboard circuit breakers.

- Follow manufacturers' startup recommendations for load equipment.

5.3 Normal Shutdown

The normal shutdown procedure for an RPP is to first shut down the Modular Compact RPP's load equipment according the equipment manufacturers' instructions. For example, shut down the operating system on a server, including powering down the server.

Then, turn OFF the associated panelboard circuit breakers on the Modular Compact RPP.

After all panelboard breakers have been turned OFF, turn OFF the main feeds(s) to the Modular Compact RPP panelboard(s).

If the Modular Compact RPP is to be moved or upgraded, also turn OFF PDU or building power to the main feeds and lock out power to the Modular Compact RPP.

5.4 Mission Critical Modular Compact RPP Dual Input Transfer Procedures

A Mission-Critical Modular Compact RPP has dual voltage inputs, but only one at a time supplies power to the RPP. Voltage can be continuously supplied to the load while one main feed and panelboard are effectively offline. The dual inputs are switched manually using Kirk Keys with a Solenoid Key Release (transfer initiate switch). See [5.4 Mission Critical Modular Compact RPP Dual Input Transfer Procedures](#).

- Circuit breaker Main 1 is for the Primary Source (1).
- Circuit breaker Main 2 is for the Alternate Source (2).

Figure 10. Mission Critical Transfer Controls

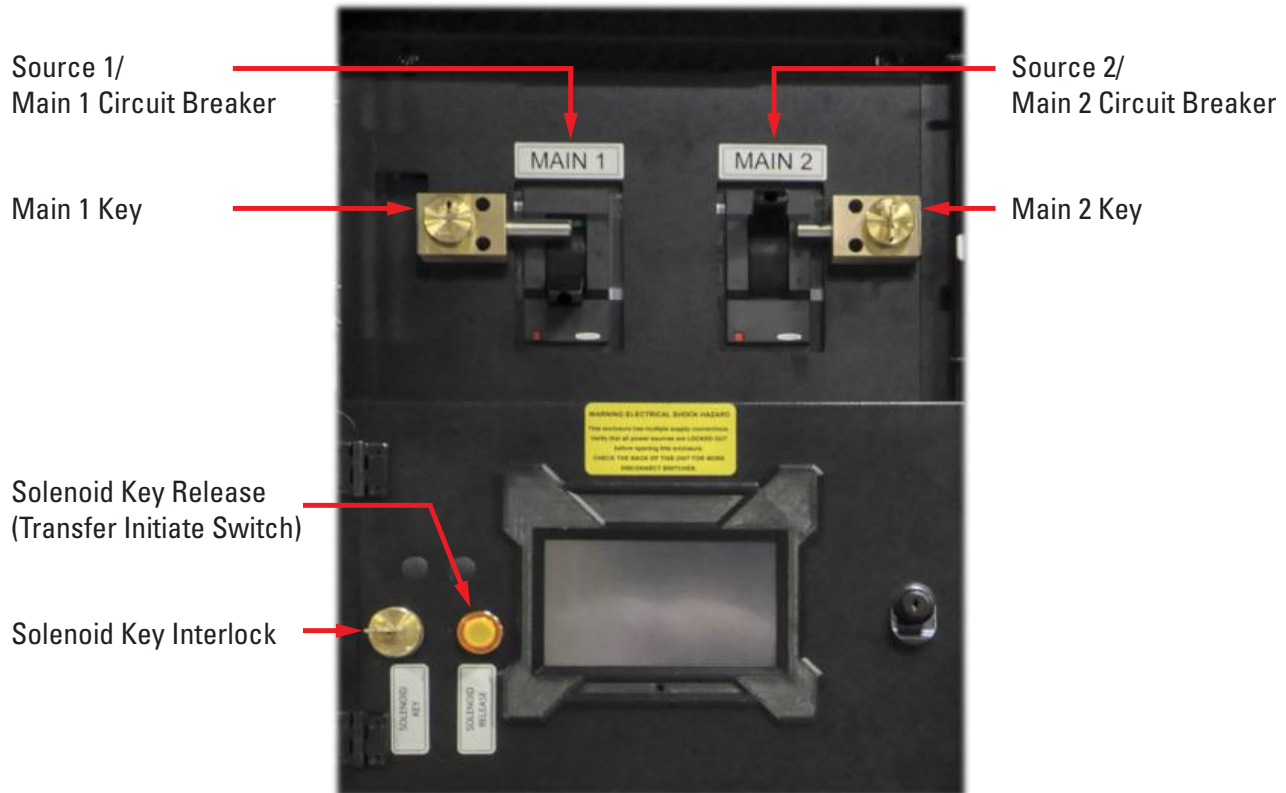

5.4.1 Normal Operation

The normal status for voltage input is as follows:

1. The Primary Source (1) is supplying power to the critical load.
2. Circuit Breaker Main 1 (Primary Source) is closed and its key is trapped.
3. Circuit Breaker Main 2 (Alternate Source) is locked open with no key trapped.
4. Solenoid Key Interlock is DE-ENERGIZED and the interlock key is trapped.

When the Solenoid Key Release button is lighted, the two sources are synchronized and power can be transferred from one source to another.

5.4.2 Transfer from Primary Source to Alternate Source

To transfer power input from the Primary Source to the Alternate Source:

1. Depress the Solenoid Key Release (transfer initiate switch). Unlock and remove the key from the Solenoid Key Interlock.
2. Insert the key into Main 2. Unlock and close Main 2.
3. Open circuit breaker Main 1 and lock open. Remove the key from Main 1.

4. Insert the key into the key interlock and turn to lock.

5.4.3 Transfer from Primary Source to Alternate Source

To transfer power input from the Alternate Source to the Primary Source:

1. Depress the Solenoid Key Release (transfer initiate switch). Unlock and remove the key from the Solenoid Key Interlock.
2. Insert the key into the Main 1 lock. Unlock and close circuit breaker Main 1.
3. Open circuit breaker Main 2 and lock open. Remove the key from Main 2.
4. Insert the key into the key interlock and turn to lock.

Chapter 6 Monitoring

Modular Compact RPPs have several monitoring options:

- WaveStar Monitoring with Color Monitor and Branch Circuit Monitoring System (BCMS).
- BCMS only
- Square D monitoring
- No monitoring

WaveStar monitoring components, the Color Monitor and BCMS, should be ordered with the unit and installed at the factory.

6.1 BCMS

Each Modular Compact RPP can have one (1) BCMS PCB, which can monitor up to 2 x 42-pole panelboards or 1 x 84-pole panelboard with their main feeds.

Each panelboard with its associated main feed is represented by a points list. A 42-pole panelboard is represented by a single panelboard points list. An 84-pole panelboard is represented by two (2) panelboard points lists.

Points lists are loaded onto BCMS PCBs at the factory. Several points lists are available:

- **BCMS Normal** panelboard points list allows customization of circuit breaker alarms and warnings for each panelboard circuit.
- **BCMS KWH** points list provides accumulated KWH measurements and other detailed power information for each panelboard circuit.
- **BCMS IEC** panelboard points list is for IEC format panelboards with 36 or 72 1P circuits.

See the **Bibliography** for information on downloading points lists from the PDI website.

6.2 Color Monitor and Protocols

When Modular Compact RPPs are combined in a modular cluster, a single Color Monitor can display power information for up to (7) Modular Compact RPP units or up to (14) panelboards.

The Color Monitor supports several protocols, which can all be used simultaneously.

Downstream Protocol The downstream device network has fixed parameters of Modbus RTU, 9600 baud, EVEN parity.

Upstream Protocols The Monitor has separate upstream ports for Modbus RTU and Ethernet, supporting these protocols:

- Modbus RTU
- Ethernet port
 - TCP/IP, used by the Color Monitor's web page server
 - Modbus TCP/IP
 - SNMP Version 1

For in-depth information on the Color Monitor, including setup, networking, commands and replies, screens, and web pages, see *WaveStar Color Monitor, Setup and Operation*, PM375103.

6.3 Customer Network Connections

6.3.1 Modbus Connections

Each Modular Compact RPP with an installed Color Monitor has a terminal block in the Display/Control section for connecting Modbus RTU wiring. The Color Monitor is connected via Modbus RTU to the terminal block, allowing customers to make upstream connections without touching a BCMS PCM or Color Monitor backpanel. A label is attached next to the terminal block showing Modbus connections.

Figure 11. Modbus Terminal Block in Display/Control Compartment

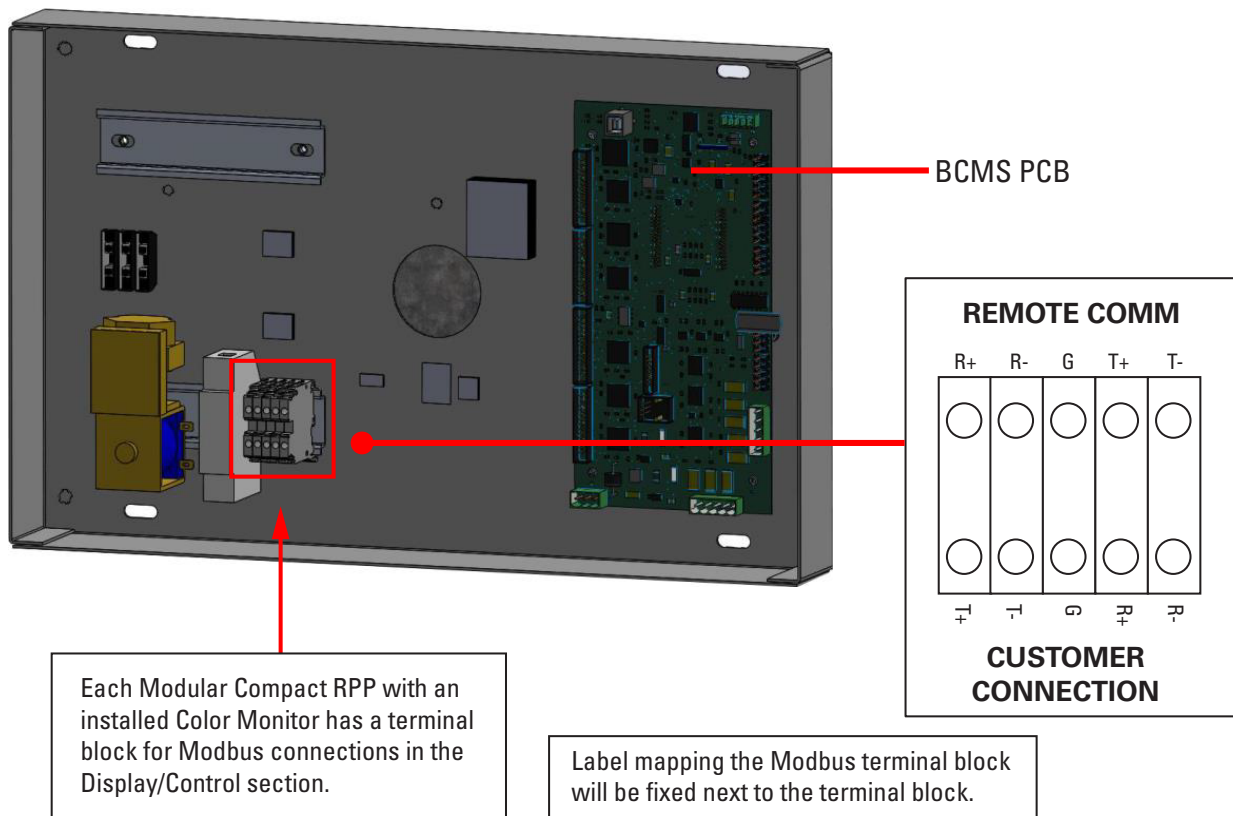

6.3.2 Ethernet Upstream Cables

The customer network Ethernet cable must be connected directly to the Color Monitor backpanel (see [Figure 15](#)). The customer's choice of Ethernet cable determines the maximum length of Ethernet cable.

6.4 Networking Modular Compact RPPs Together

A Color Monitor can display power information for up to (7) Modular Compact RPP units or up to (14) panelboard "devices". The points lists representing the panelboards on these Modular Compact RPPs are downstream devices to the Color Monitor. Downstream devices use Modbus RTU protocol.

Each Modular Compact RPP has (1) BCMS PCB that can monitor (2) panelboards. The BCMS PCB is wired to the Modbus terminal block on its Modular Compact RPP unit (see [Figure 10](#)).

BCMS PCBs downstream of the Color Monitor should be wired in a Modbus RTU daisy-chain to the Monitor (see [Figure 12](#)).

BCMS PCBs have a single Modbus RTU connector for wiring Modbus RTU upstream or downstream of the PCB (see [Figure 13](#)).

Figure 12. Modbus Wiring in a Modular Cluster

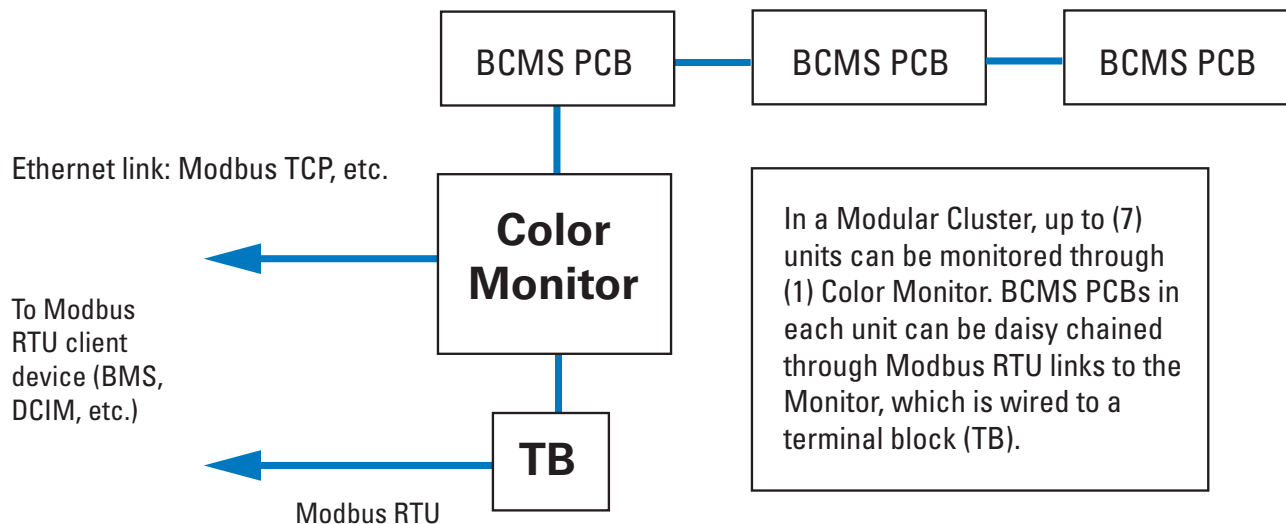

Downstream from Monitor: Modbus RTU Daisy Chain

Upstream from Monitor: Various Protocols Allowed.

Figure 13. BCMS PCB Modbus Connection in Display/Control Section

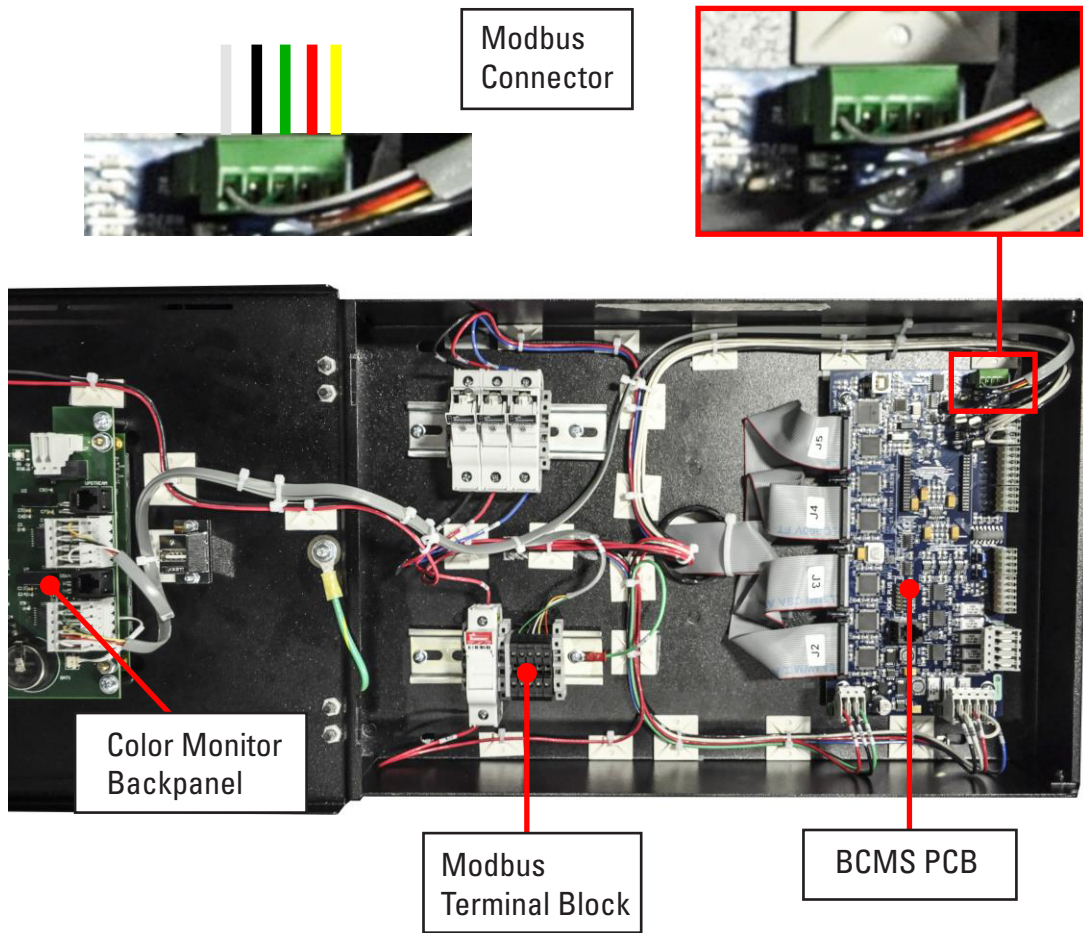

6.5 Modbus Addressing

Figure 14. Modbus Addressing

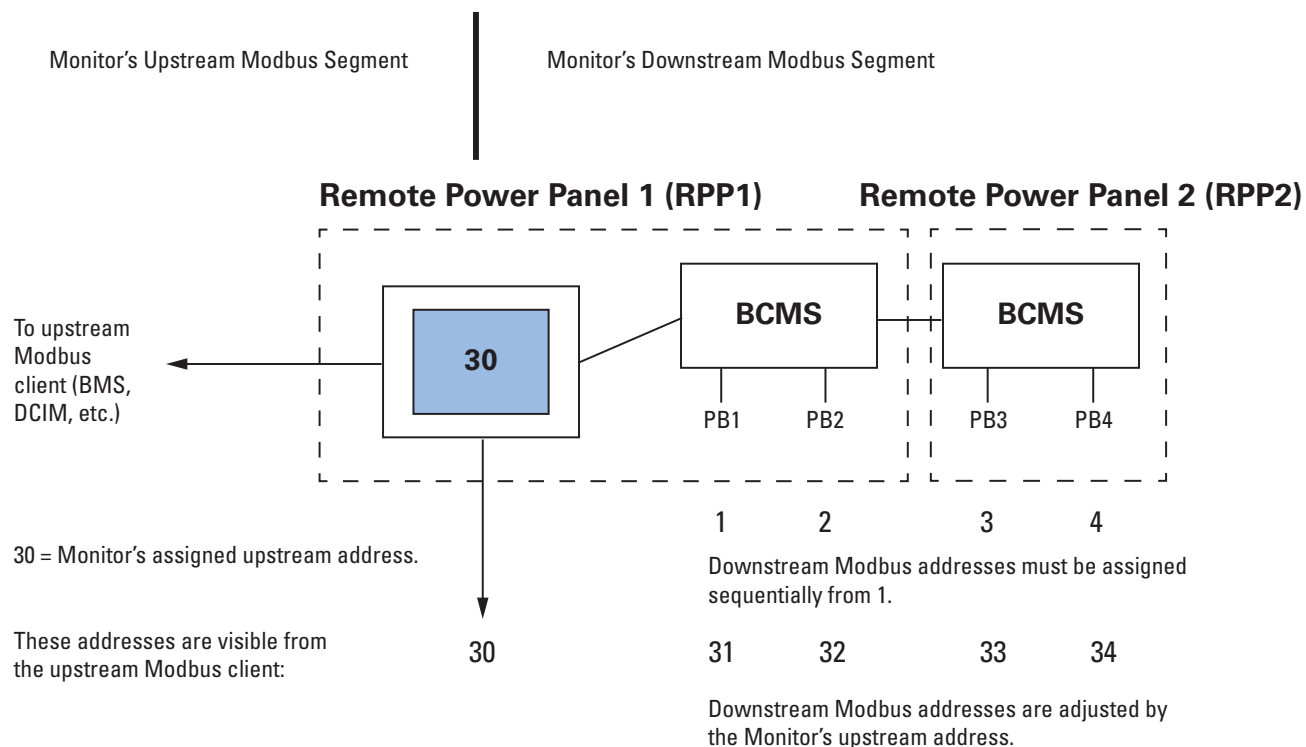

Refer to [Figure 14](#), with the following bullet points:

- The Monitor is a Modbus client to its downstream devices. The upstream Modbus client cannot directly address these devices, but rather addresses them through the Monitor. Upstream and downstream are separate Modbus segments.
- The Monitor's upstream address can be set to from 1 to 255, but you must leave enough addressing capacity for downstream devices. The monitor will not respond to a command sent to address 0. The address is set during Monitor Setup.
- The Monitor's downstream devices must be assigned consecutive addresses starting at address 1. Modbus addresses must be assigned in BCMS setup and will be done initially at the factory. Modbus addresses cannot be assigned by, for example, the BMS.
- For upstream addressing these device addresses are remapped as successor addresses to the Monitor. If the Monitor has upstream address 30, the downstream addresses 1, 2, 3, 4 are remapped to 31, 32, 33, 34 as seen from the BMS or other Modbus client.
- Modbus addressing is the same for Modbus RTU and Modbus TCP/IP.

6.6 Network Connections Details

6.6.1 Color Monitor Network Connections

The Color Monitor's backpanel has Modbus RTU and Ethernet ports (see [Figure 14](#)).

Modbus RTU backpanel connections are typically made in manufacturing and extended to a terminal block or external panel for convenient customer access. The customer's Ethernet cable is connected directly to the Monitor's Ethernet port.

Figure 15. Color Monitor Backpanel Network Connections

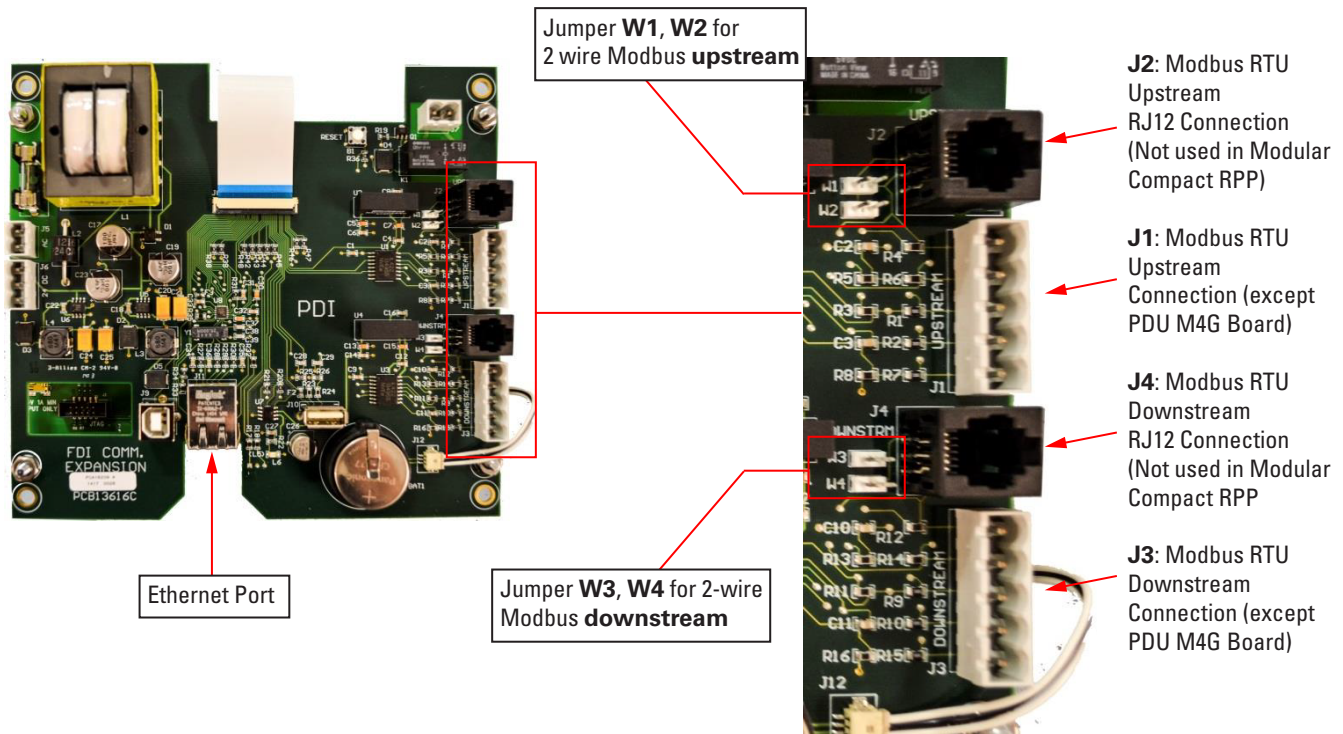

6.6.2 Modbus RTU Ports

The Color Monitor has four (4) paralleled Modbus ports:

1. J1 and J3 are header/plug connections for connecting to most devices.
 - a. J1 is the upstream port.
 - b. J3 is the downstream port.
2. J2 and J4 accept standard RJ12 phone cable plugs for connection to an M4G PDU board.
 - a. J2 is the upstream port.
 - b. J4 is the downstream port.

The Modbus RTU interface is isolated, and pin designations are given in Table 2:

Table 2. Pin-Out for Modbus Headers

Pin	J1, J3
1	Ground
2	RX-
3	RX+
4	TX-
5	TX+

6.6.3 Modbus RTU 2-Wire vs. 4-Wire Configuration

PDI devices have two (2) jumpers near their Modbus ports for configuring 2-wire vs. 4-wire Modbus RTU (see [Figure 15](#)). The Monitor's 2-wire configuration jumpers are W1 and W2 (upstream) and W3 and W4 (downstream). Upstream and downstream chains can be differently configured.

For 2-wire configuration:

- At least one device in a device chain must have both jumpers jumped on its Modbus connection. If any device in the chain has jumpers installed for 2-wire, all of the device chain is 2-wire. To avoid confusion when troubleshooting, all of the devices in the chain should be jumped in the same way.
- TX+ or RX+ on the Monitor (either one, because the on-board 2-wire jumpers short them together) wires to TX+ or RX+ on downstream devices.
- TX- or RX- on the Monitor wires to TX- or RX- on downstream devices.
- The + and - signal wires should comprise of a (twisted) wire pair residing in the same shield.

For 4-wire configuration:

- All of these jumpers must be removed from every device in the chain.
- TX+ on the first device PCB wires to RX+ on a second PCB.
- TX- from the first device PCB wires to RX- of the second PCB.
- A second pair of wires connects the other pair of TX+ / RX+ & TX- / RX-.
- The TX+ & TX- going to the RX+ & RX- should be in the same shield. Do not run the +'s in one shield and the -'s in another. Doing so may lead to sporadic communication.
- Run a dedicated ground wire with the signal wires and only ground the shield at one end.

6.6.4 Modbus RTU Upstream Cable Specification

RS485/RS422 cable length can be up to 4000 ft. if you use the proper cable:

1. The cable resistance should be ≤ 27 ohms/1000ft @ 1 kHz and the mutual capacitance should be ≤ 14 pf/ft. @ 1 kHz.
2. 4-wire cabling:
 - a. RS422 is typically 4-wire.
 - b. Use a shielded cable with two (2) twisted pairs and a shield/ground wire.
 - c. The two transmit lines must be in one twisted pair and the two receive lines in the other twisted pair.
3. 2-wire cabling:
 - a. RS485 is typically 2-wire and is slower than RS422.

- b. Use a shielded cable with one (1) twisted pair and a shield/ground wire.

6.6.5 Modbus RTU Cable Biasing and Termination

Eaton devices have soft biasing (27K pull-up and pull-down resistors) on the + and – transmit and receive lines. Therefore, if the customer's client device allows for control, PDI recommends that the user turn on biasing and turn off termination, which may "fight" the biasing. Biasing the client device's lines is not critical because the Color Monitor is already biasing the lines. If termination is needed because of an extremely long cable run, Eaton recommends that a small capacitor be put in series with the terminating resistor.

Chapter 7 Resources

7.1 Bibliography

Manuals for Related Products

JCOMMs can have an optional Eaton PDI WaveStar Color Monitor or can be monitored from a Eaton PDI WaveStar BCMS Hub.

- Eaton PDI WaveStar® Color Monitor, Setup and Operation, P-164001109
- Eaton PDI WaveStar BCMS Hub Installation and Operation, P-164001108

Points Lists

Points Lists Points lists can be downloaded from the Eaton website. Go to Service Software Downloads:

<https://www.eaton.com/services/service-software-downloads/>

For BCMS points lists, Contact Eaton Service, See paragraph :

Once the software file is received, unzip the file and open the directory \Points List for BCMS Version to find the following points lists and use the latest revision given:

- **BCMS Normal** panelboard points list is "BCMSII points list".
- **BCMS KWH** panelboard points list is "BCMSII plus points list Power KWH".
- **BCMS IEC** panelboard points list (for IEC format panelboards with 36 or 72 1P circuits) is "72 BCMSII plus points list Europe KWH".

7.2 Getting Help

If help is needed with any of the following:

- Scheduling initial startup
- Regional locations and telephone numbers
- A question about any of the information in this manual
- A question this manual does not answer

Please call the Help Desk at:

United States:	1-800-843-9433
Canada:	1-800-461-9166 ext 260
All other countries:	Call your local service representative

Please use the following e-mail address for manual comments, suggestions, or to report an error in this manual:

E-ESSDocumentation@eaton.com

7.3 Warranty and End User License Agreement

To view the warranty please click on the link or copy the address to download from the Eaton website:

[Eaton Product Warranty](#)

<https://www.eaton.com/content/dam/eaton/products/backup-power-ups-surge-it-power-distribution/backup-power-ups/portfolio/eaton-three-phase-ups-warranty.pdf>

To view the End User License Agreement please click on the link or copy the address to download from the Eaton website:

[Eaton End User License Agreement](#)

<https://www.eaton.com/content/dam/eaton/products/support-systems/software-and-cad-registration-form/eaton-end-user-software-license-agreement.pdf>

7.4 Equipment Registration

Please visit www.eaton.com/pg/register to register your new Eaton UPS / Eaton UPS Accessory.

Model Number:

Serial Number:



P-164001111 01