

8 7 6 5 4 3 2 1

D
C
B
A

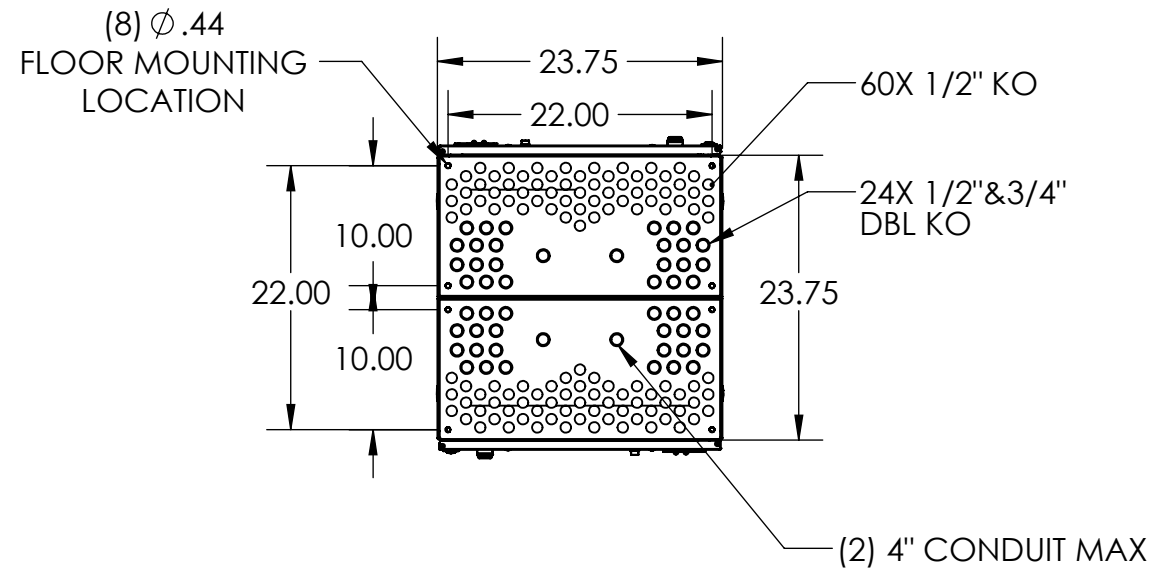
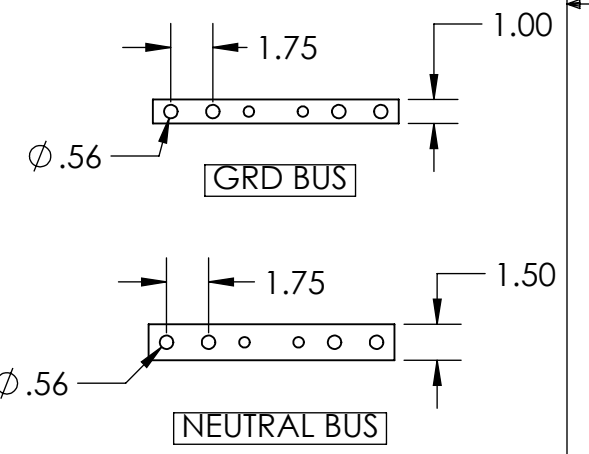
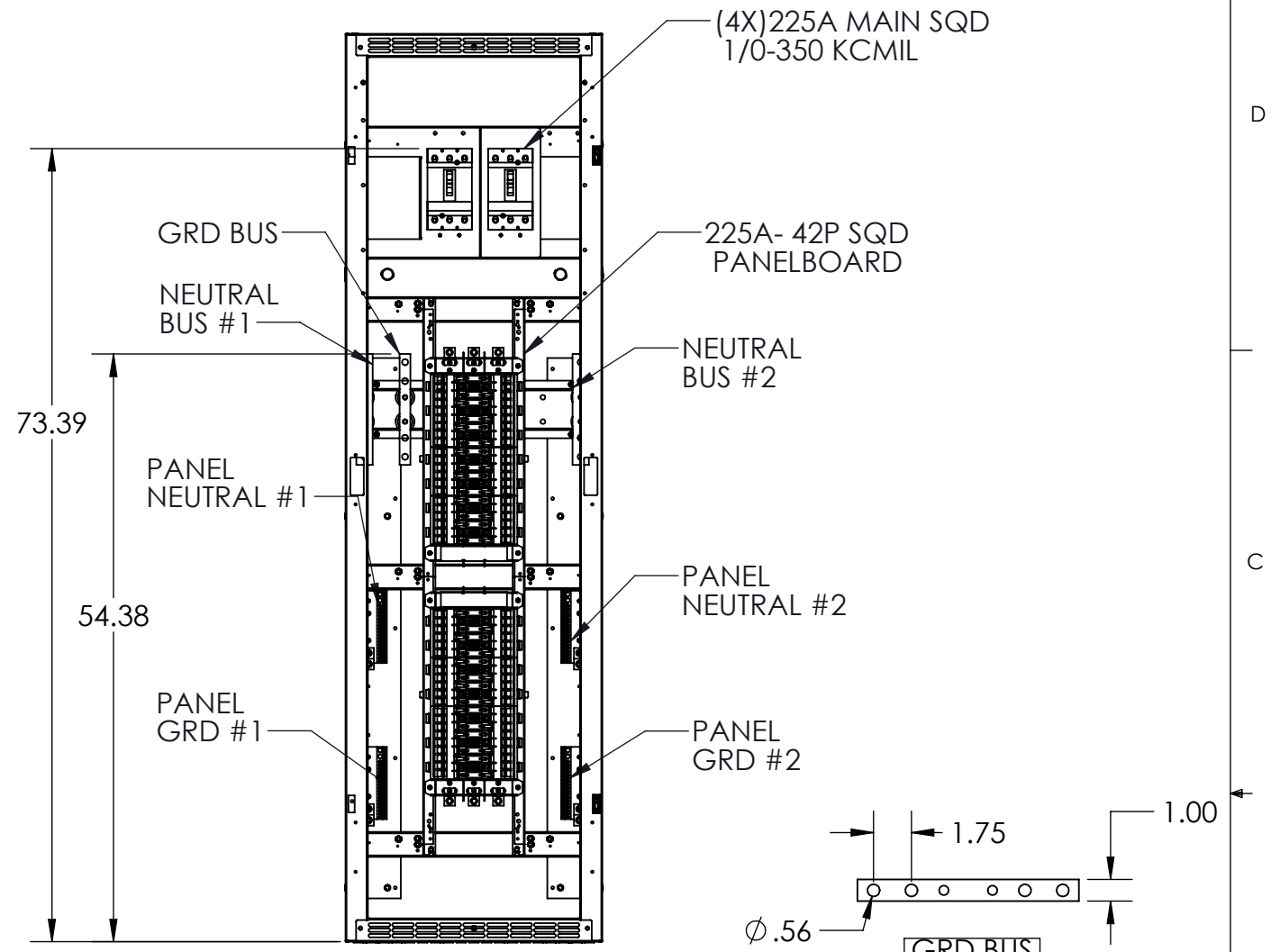
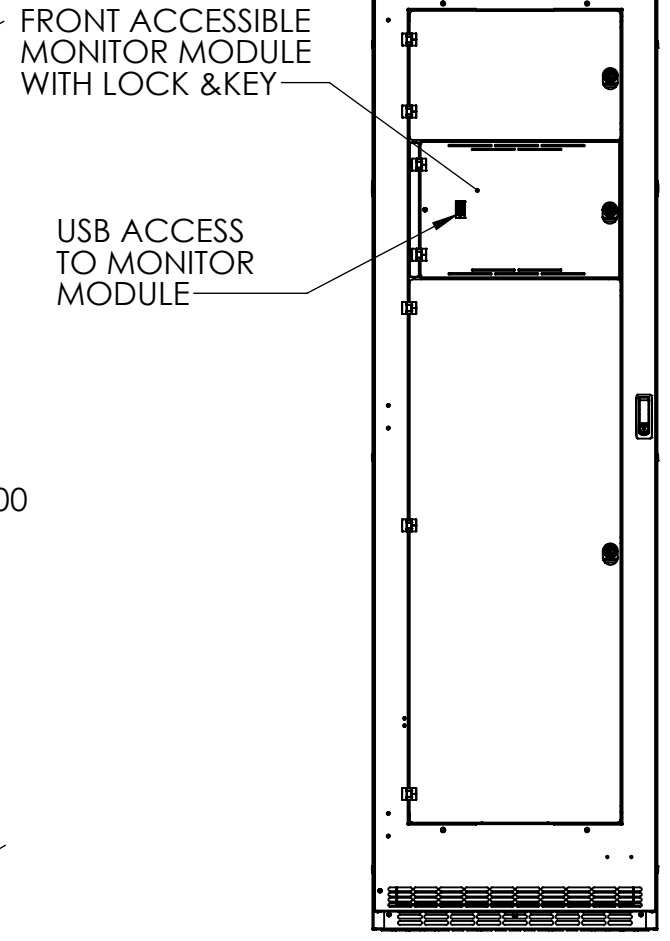
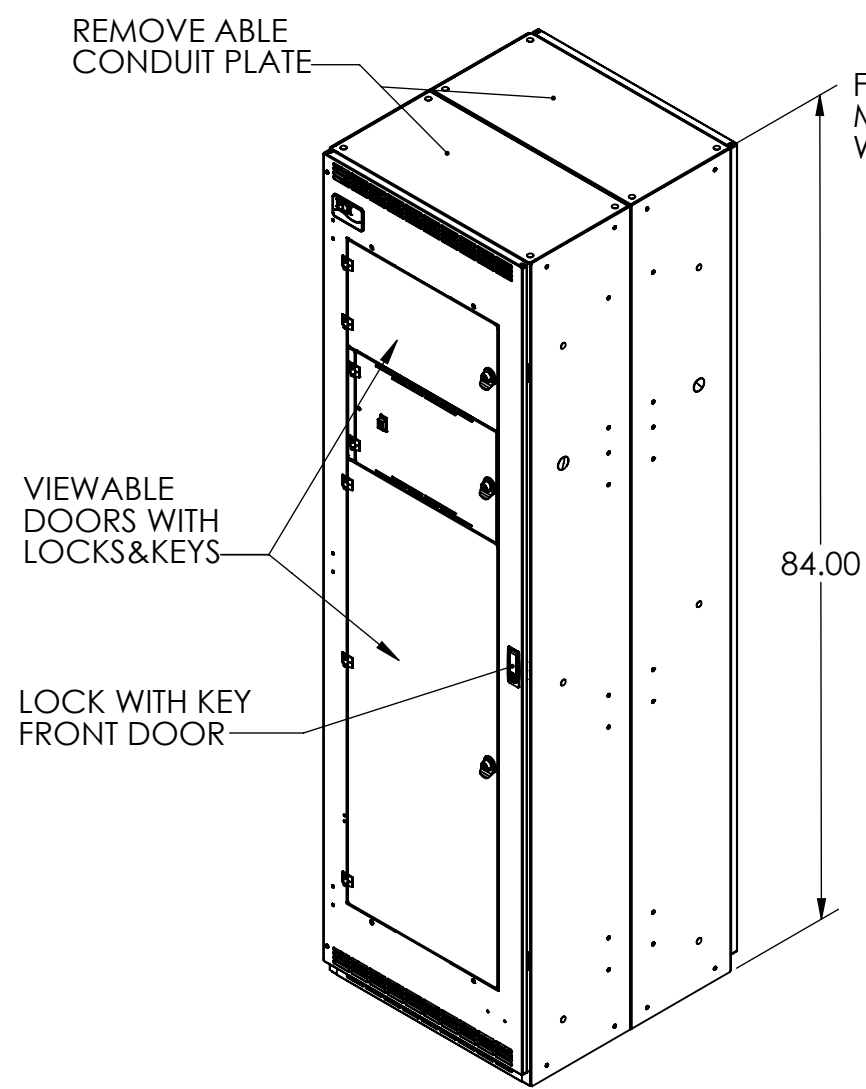

GENERAL SPECIFIED

CABINET CHARACTERISTIC:
 ENCLOSURE : NEMA 1
 LOCATION : INDOOR
 MOUNTING: FLOOR or FLOOR STAND(OPTIONAL)
 MATERIAL: STEEL
 FINISH: EXTERIOR PANELS: POWDER COAT
 WEIGHT : 375 LBS. APPROX.
ELECTRICAL:
 (4) INPUT: 208 VAC 3PH-4W W/GND @ 60 HZ, 250A (MAX)
 (4) OUTPUT :42 POLE, BOLT ON CIRCUIT BREAKER (60 A MAX)
 ALL CUSTOMER SUPPLIED CABLE CONNECTIONS BASE ON 75 °C COPPER WIRE.
 CONSULT NEC & LOCAL REGULATIONS.

UNLESS OTHERWISE SPECIFIED:
 DIMENSIONS ARE IN INCHES
 [] IN MILLIMETER
 ANGULAR: ±0.5° BEND ±1°
 TWO PLACE DECIMAL ±0.02
 THREE PLACE DECIMAL ±0.005

THIS DRAWING CONTAINS CONFIDENTIAL & PROPRIETARY INFORMATION AND SHALL NOT BE DISCLOSED OR COPIED WITHOUT THE EXPRESSED, WRITTEN PERMISSION OF PDI

PDI

THIRD ANGLE PROJECTION		DO NOT SCALE DRAWING	
APPROVALS		DATE	
DRAWN	LJN	2/1/18	
CHECKED			
ENG. APPR.			

TITLE: MCRPP MODEL C (4) 225A-42P SQD, WITH MAIN, NO MONITORING		
SIZE	DWG. NO.	REV
B	12617005	A
PART NO.		SHEET 1 OF 1

8 7 6 5 4 3 2 1