

REV	ECO No.	REVISION	DR	CK	AP	DATE

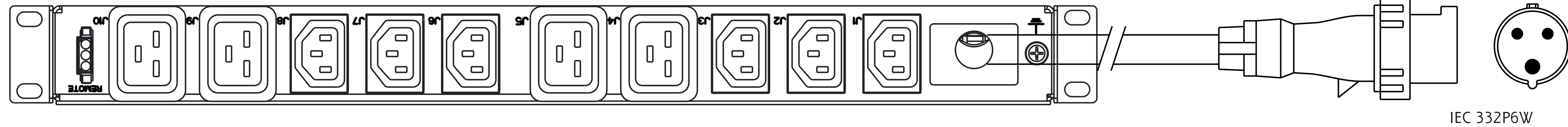

IEC 332P6W

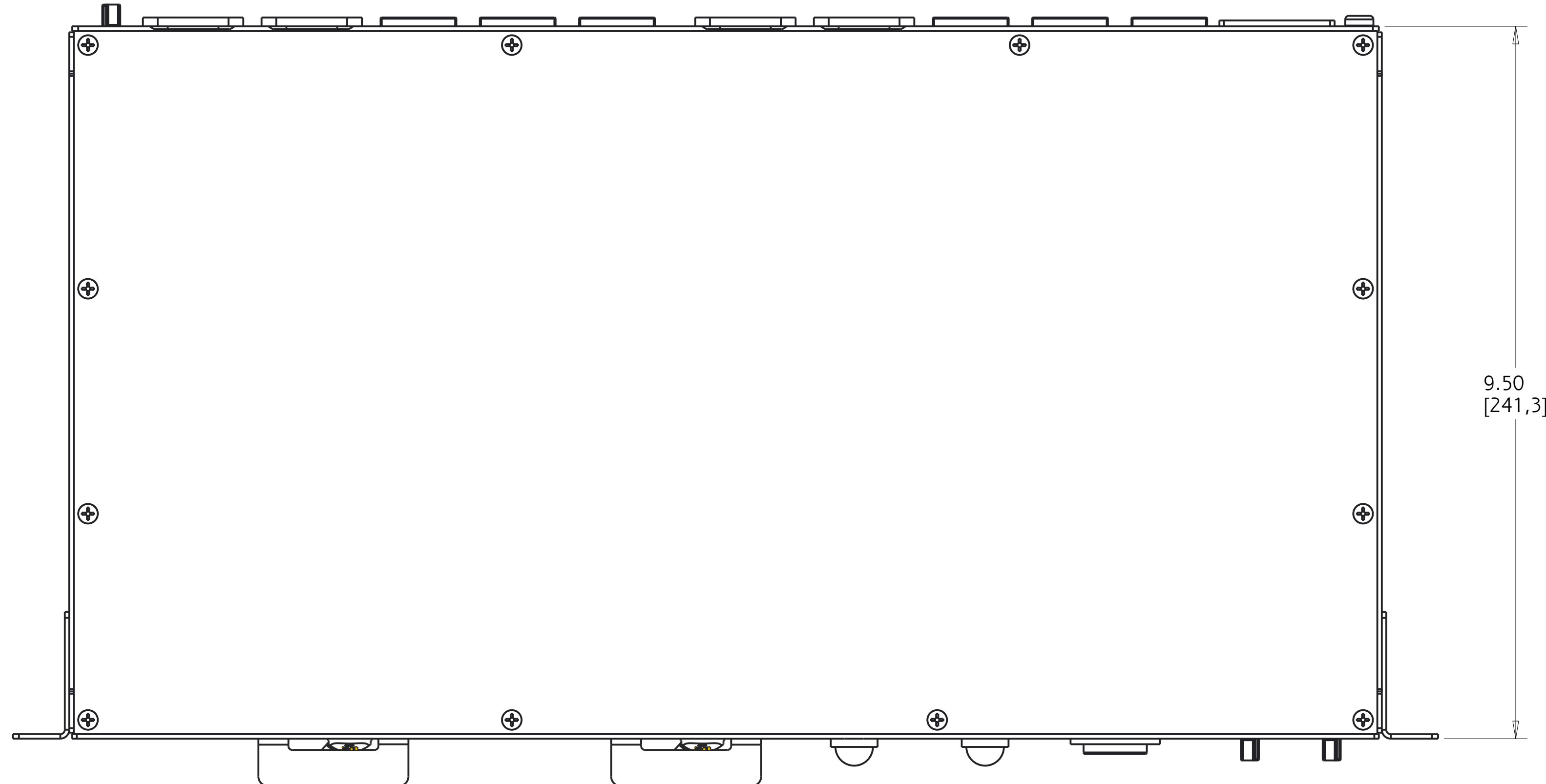

9.50  
[241,3]

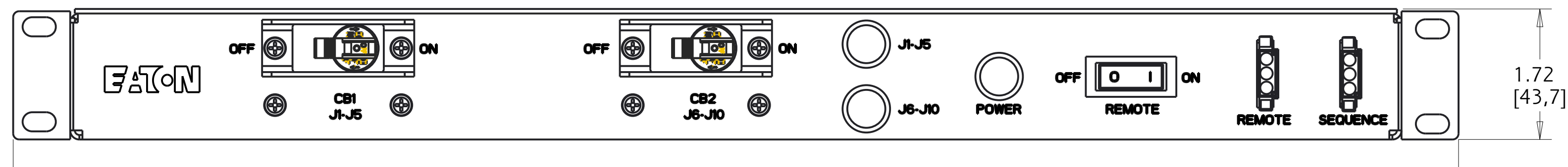
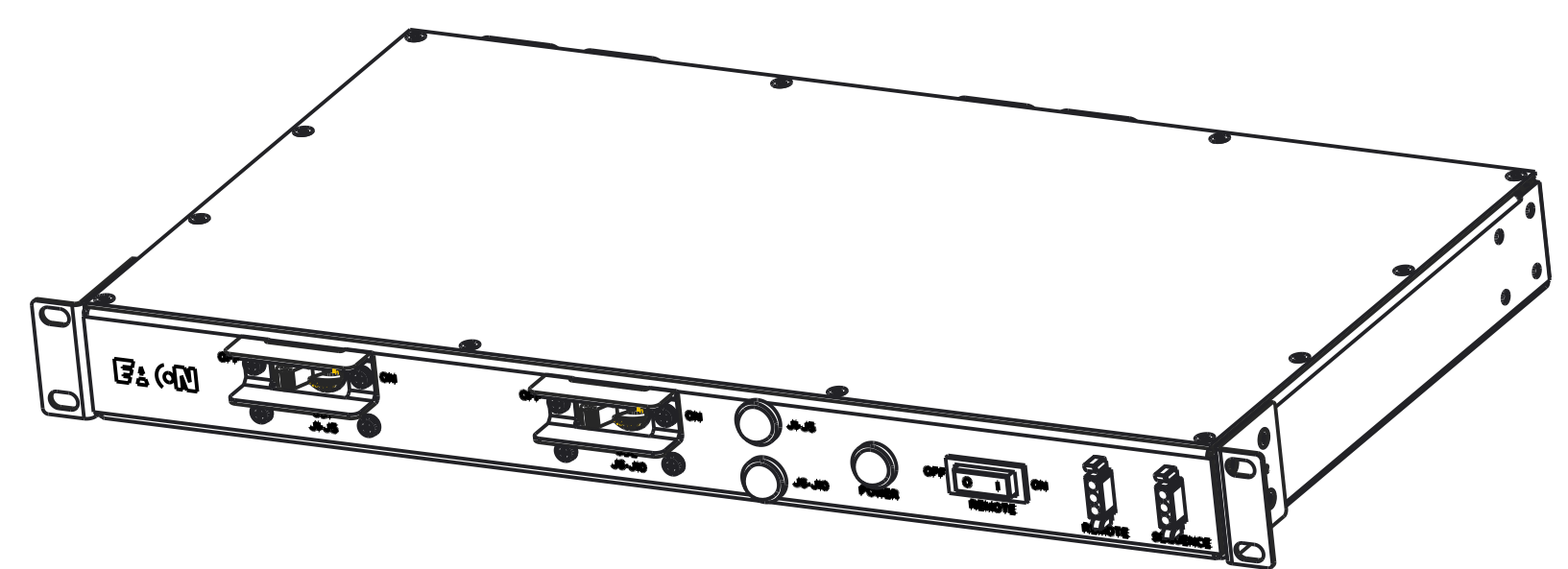

1.72  
[43,7]

19.00  
[482,6]

# TPC2365-5812R REMOTE CONTROL

<b>FUNCTIONALITY</b> POWER CONTROLLER WITH LATCHING REMOTE	<b>INPUT</b> IEC 332P6W PLUG 15FT 10/3 UL/CSA/HAR PWRCORD	<b>OUTPUT</b> (6) IEC C13 (4) IEC C19	<b>ENVIRONMENTAL</b> 32° TO 113° F 0° TO 45° C
<b>MECHANICAL</b> 19.00" (482.6mm) WIDTH 1.72" (43.7mm) HEIGHT 9.50" (241.3mm) DEPTH BLACK CHASSIS	<b>INPUT RATING</b> 200-240V ~ 2W + PE OR W + N + PE 24A 50/60HZ	<b>OUTPUT RATING</b> 200-240V ~ ; 50/60HZ 12A AT C13 16A AT C19 16A PER SECTION 24A MAX TOTAL	<b>CERTIFICATIONS</b>
<b>CIRCUIT BREAKER</b> (2) 20A 2-POLE UL LISTED	<b>FILTER AND SPIKE/SURGE</b> EMI/RFI FILTER, COMMON AND DIFFERENTIAL MODE SPIKE/SURGE PROTECTION	<b>INDICATOR LIGHTS: 3 GREEN</b> ONE FOR MAIN POWER ONE FOR EACH SECTION (2)	<b>ACCESSORIES INCLUDED</b> SUB-HRDWARE-001 - PANEL MOUNT KIT SCREWS SPK030 - PANEL MOUNT KIT CAGE NUTS REMOTE02 - REMOTE CONNECTOR KIT (3)

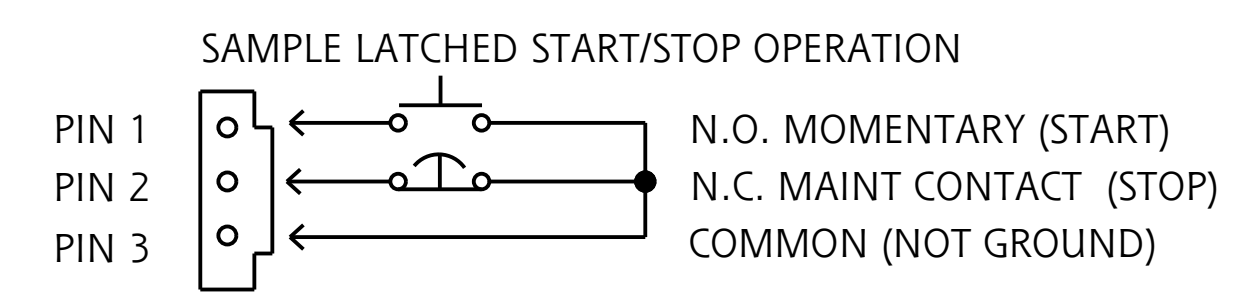

REMOTE CONNECTOR

LATCHED REMOTE: REMOTE START ONLY.  
 MTD: SECTIONS POWER UP AT 4-SECOND INTERVALS WHEN UNIT IS STARTED.

THIRD ANGLE PROJECTION		EATON CORPORATION, ELECTRICAL		EATON	SIZE D
SPECIFICATION DRAWING TPC2365-5812R					
MODIFIED BY: J. OSBORNE	DATE: 16 SEPT 2019	UNLESS OTHERWISE SPECIFIED TOLERANCES ON DIMENSIONS ARE: ANGLES: ±10° HOLES: ±0.013		SCALE: 0.800 DO NOT SCALE DRAWING OR CHANGE MANUALLY	
ECO: 172314	STATE: RELEASE	DECIMALS: 0.X (FOR X < 3); ±1	INCHES: ±0.25 X (FOR X > 3); ±2.5		
PRO-ENGINEER GENERATED		PART NAME: TPC2365-5812R	REVISION: 01	SHEET: 1 of 1	
<small>EATON CORPORATION - CONFIDENTIAL AND PROPRIETARY NOTICE TO PERSONS RECEIVING THIS DOCUMENT AND/OR TECHNICAL INFORMATION THIS DOCUMENT, INCLUDING THE DRAWING AND INFORMATION CONTAINED THEREON, IS CONFIDENTIAL AND IS THE EXCLUSIVE PROPERTY OF EATON CORPORATION AND IS SUBJECT TO RECALL BY EATON AT ANY TIME. BY TAKING POSSESSION OF THIS DOCUMENT, THE RECIPIENT ACKNOWLEDGES AND AGREES THAT THIS DOCUMENT CANNOT BE USED IN ANY MANNER ADVERSE TO THE INTERESTS OF EATON, AND THAT NO PORTION OF THIS DOCUMENT MAY BE COPIED OR OTHERWISE REPRODUCED WITHOUT THE PRIOR WRITTEN CONSENT OF EATON. IN THE CASE OF CONFLICTING CONTRACTUAL PROVISIONS, THIS NOTICE SHALL GOVERN THE STATUS OF THIS DOCUMENT. © 2008 Eaton Corporation - All Rights Reserved.</small>					