

# Harmonic correction unit and electronic VAR injector active filters installation manual, 380–480 V units, NEMA 2, NEMA 12, IP31 and IP54 versions



## Contents

Description	Page
<b>Important information</b> .....	2
<b>Definition of symbols</b> .....	2
<b>Warnings and cautions</b> .....	2
<b>Safety precautions</b> .....	3
<b>Introduction</b> .....	3
Harmonic correction unit .....	3
Electronic VAR injector .....	3
<b>Receiving, handling, and storing</b> .....	4
Receiving .....	4
Inspection .....	4
Handling .....	4
Storing .....	4
<b>Installation</b> .....	4
Foundation preparation .....	4
Installation .....	5
Environmental requirements .....	5
Physical installation .....	5
Standard units physical description .....	5
Dimensional drawings .....	6
Attaching the enclosure to the floor .....	10
Electrical connection .....	10
Current transformers (CTs) .....	14
Parallel system .....	18
Wiring diagrams .....	19
Parallel communication .....	23
Control wiring .....	24
<b>Pre-commissioning</b> .....	26
Instruments required for commissioning .....	26
Pre-energizing procedure .....	26
Installation inspection .....	26
Pre-commissioning checklist .....	26
Commissioning procedures .....	26
<b>IT, HRG, and corner grounded systems</b> .....	27
<b>Catalog numbering system</b> .....	31
<b>Warranty</b> .....	31



Powering Business Worldwide

## Important information

Read these instructions carefully and look at the equipment to become familiar with the device before trying to install, operate, service or maintain it. The following special messages may appear throughout this bulletin or on the equipment to warn of potential hazards or to call attention to information that clarifies or simplifies a procedure.

## Definition of symbols

---

### WARNING

---

**This symbol indicates high voltage. It calls your attention to items or operations that could be dangerous to you and other persons operating this equipment. Read the message and follow the instructions carefully.**



This symbol is the “Safety Alert Symbol.” It occurs with either of two signal words: CAUTION or WARNING, as described below.

---

### WARNING

---

**Indicates a potentially hazardous situation which, if not avoided, can result in serious injury or death.**

---

### CAUTION

---

Indicates a potentially hazardous situation which, if not avoided, can result in minor to moderate injury, or serious damage to the product. The situation described in the CAUTION may, if not avoided, lead to serious results. Important safety measures are described in CAUTION (as well as WARNING).

## Warnings and cautions

---

### WARNING

---

#### Hazard of personal injury.

- Use proper lifting equipment such as an overhead crane to handle the active filter
- Do not lay the equipment on its front

**Failure to follow these instructions can result in death, serious injury, or equipment damage.**

---

### CAUTION

---

#### Risk of equipment damage.

Adhere to DC choke, SCR based rectifier, and capacitor placement requirements.

**Failure to follow this instruction can result in equipment damage.**

---

### CAUTION

---

#### Risk of equipment damage.

Ensure that the installation location satisfies environmental requirements.

**Failure to follow this instruction can result in equipment damage.**

---

### WARNING

---

#### Hazard of personal injury.

- The unit must be properly grounded before power is applied.
- Ground equipment using the ground connecting point provided.

**Failure to follow these instructions will result in death or serious injury.**

## Safety precautions

Installation, wiring, testing, and service must be performed in accordance with all local and national electrical codes.

---

### WARNING

---

**Lockout/tagout all electrical source circuits feeding the unit(s) in the open position before beginning wiring or terminations. Failure to follow the instructions could result in severe bodily injury or death. Only qualified personnel familiar with the operation and construction of this equipment should install, adjust, modify, and service this equipment.**

---

### WARNING

---

#### **Hazard of electric shock, explosion, or arc flash.**

- Apply appropriate personal protective equipment (PPE) and follow safe electrical work practices. See NFPA 70E in the USA, CSA® Z462, or applicable local standards
- This equipment must be installed and serviced only by qualified electrical personnel
- Do not exceed the device's ratings for maximum limits
- Ground equipment using the ground connecting point provided before turning on any power supplying this device
- Turn off all power supplying this device and the equipment in which it is installed before working on the device or equipment
- After removing power, wait for 15 minutes to allow the capacitors to discharge prior to opening the doors or removing covers
- Always use a properly rated voltage sensing device to confirm power is off
- Replace all devices, doors, and covers before turning on power to this equipment
- Carefully inspect the interior for tools left behind before closing and sealing the door

**Failure to follow these instructions will result in death or serious injury.**

## Introduction

The product can be provided in either of two types, an Harmonic Correction Unit (HCU2) or an Electronic VAR Injector (EVI2). Both types are to be installed as described in this manual. These products are both referred to as an active filter in this manual.

### Harmonic correction unit

Harmonic Correction Units (HCU2) are static power electronic products that employ digital logic and IGBT semiconductors to synthesize a current waveform that is injected into the electrical network to cancel harmonic currents caused by nonlinear loads. HCU2 employ current transformers to measure the load current to determine the content of harmonic current present. By injecting the synthesized current, network harmonic currents are greatly mitigated, thus reducing the heating effects of harmonic current and reducing voltage distortion.

HCU2 also have the ability to correct for poor displacement power factor (DPF) and for mains current balancing. DPF correction can be provided for either leading (capacitive) or lagging (inductive) loads that cause poor DPF. Mains current balancing is achieved by measuring the negative sequence current present and injecting the inverse negative sequence current to balance the current for the upstream network.

Multiple enclosure styles are available. Chassis mount open chassis designs can be installed in other types of enclosures such as motor control centers (MCC).

### Electronic VAR injector

Electronic VAR Injector (EVI2) are static power electronic products that employ digital logic and IGBT semiconductors to synthesize a current waveform that is injected into the electrical network to cancel load induced poor displacement power factor (DPF), phase current unbalance, and flicker. DPF correction can be provided for either leading (capacitive) or lagging (inductive) loads that cause poor DPF. Mains current balancing is achieved by measuring the negative sequence current present and injecting the inverse negative sequence currents to balance the current for the network.

Multiple enclosure styles are available. Chassis mount open chassis designs can be installed in other types of enclosures such as motor control centers (MCC).

## Receiving, handling, and storing

### Receiving

Inspect the active filter for any damage as soon as it is received. With standard shipping, transfer of the equipment to a carrier at any manufacturing plant or other shipping point constitutes delivery to the purchaser. Title and all risk of loss or damage in transit shall pass to the purchaser at that time.

### Inspection

- Check that all packages and/or crates have been delivered and that the equipment has not been damaged in transit.
- On the outside packaging and inside the unit, Drop N Tell monitoring devices are installed. If these have been activated, inform the carrier immediately.



- In the event of damaged or missing items, contact the carrier immediately. Check with them for time limits for filing claims and any documentation required such as a Bill of Lading number, etc.
- Damaged or missing items are the responsibility of the carrier and must be reported.
- Check that the information shown on the equipment nameplates corresponds with the order specifications.
- The packaging material should be replaced to protect the unit until installation has begun.

### Handling

#### **WARNING**

#### Hazard of personal injury.

- Use proper lifting equipment such as an overhead crane to handle the active filter
- Do not lay the equipment on its front

#### Failure to follow these instructions can result in death, serious injury, or equipment damage.

Ensure that the proper equipment such as an overhead crane is available at the installation site to handle the active filter. This equipment will help avoid injury to personnel and damage to the active filter.

Verify the lifting capacity of the equipment being used to handle the active filter in accordance with the shipping weight of each shipping section.

### Storing

If the active filter is not to be installed when unpacked, it should be stored indoors in a clean, dry place. The storage temperature must be between  $-20\text{ }^{\circ}\text{C}$  ( $-4\text{ }^{\circ}\text{F}$ ) and  $60\text{ }^{\circ}\text{C}$  ( $140\text{ }^{\circ}\text{F}$ ) with a maximum relative humidity of 85%, non-condensing, and a maximum dewpoint of  $37\text{ }^{\circ}\text{C}$ . It is preferable to store the unit in its original shipping container to protect the unit from potential damage.

## Installation

This section provides the information required to properly install the active filter and associated equipment for proper operation and performance. Frequently, commissioning difficulties are the result of incorrect wiring. Every precaution must be taken to assure that the wiring is done as instructed. Read and understand all instructions in this manual prior to installation.

Correct installation of the active filter is essential for proper operation of all components. Study the associated instruction books and all drawings carefully.

The location chosen for installation should provide working clearances complying with the appropriate section of the National Electrical Code® (NEC®), the Canadian Electrical Code (CEC), or applicable local standards.

#### **WARNING**

**Lockout/tagout all electrical source circuits feeding the unit(s) in the open position before beginning wiring or terminations. Failure to follow the instructions could result in severe bodily injury or death. Only qualified personnel familiar with the operation and construction of this equipment should install, adjust, modify, and service this equipment.**

The following is a summary of the steps for installation covered in this section.

1. Ensure that the line voltage is compatible with the voltage rating of the active filter.
2. Ensure the foundation is prepared for the active filter.
3. Ensure that environmental requirements are satisfied.
4. Refer to the dimensional drawings for the active filter to be installed.
5. Mount the unit in the desired location.
6. Make the electrical connections.
7. Make the CT to CT board connection.
8. Set up parallel communication if applicable.
9. When installing on Isolated Terra (IT), High Resistance Ground (HRG), or corner grounded systems, ensure that the IT/BP switches are open. Refer to "IT, HRG, and corner grounded systems" on **page 27**.
10. Make the control wiring connections, but do not energize the active filter yet.

**Note:** Commissioning and energizing the active filter requires specialized knowledge. Pre-commissioning procedures are covered in "Pre-commissioning" on **page 26**. Commissioning procedures are covered in the User Manual. Commission the active filter and energize it only if you are qualified to do so.

### Foundation preparation

The mounting location must be able to support the weight of the unit without sagging. Weight specifications are provided in **Table 2** on **page 5**.

## Installation

For optimum performance in harmonic mitigation mode, adhere to the following recommendations.

- All harmonic generating loads must have a minimum 3% line reactor or 3% DC choke installed
- SCR based rectifiers are required to have a minimum 3% line reactor
- No capacitors downstream of the Main CTs

### CAUTION

#### Risk of equipment damage.

Adhere to DC choke, SCR based rectifier, and capacitor placement requirements.

#### Failure to follow this instruction can result in equipment damage.

If these recommendations are not followed, the target harmonic level may not be met and equipment damage can occur.

#### Environmental requirements

Active filters are designed for indoor use only. They require unrestricted exchange of environmental air to the inside of the enclosure for proper cooling. Ensure that the environment meets Pollution Degree 2, i.e., does not contain conductive particles, significant amounts of dust, or corrosive or otherwise harmful gases. Normally only non-conductive pollution occurs. Temporary conductivity caused by condensation is to be expected.

### CAUTION

#### Risk of equipment damage.

Ensure that the installation location satisfies environmental requirements.

#### Failure to follow this instruction can result in equipment damage.

If environmental requirements are not adhered to, malfunction and possible destruction of the active filter may occur.

The active filter generates significant heat during operation. See the product specifications in **Table 5** on **page 11** for the watt losses for each active filter model. Ensure that the room where the active filter is mounted has adequate ventilation. Maintain ambient temperature between 0 °C (32 °F) and 40 °C (104 °F) with a maximum relative humidity of 95%, non-condensing, and a maximum dewpoint of 37 °C.

The operating temperatures are maximum and minimum levels the unit is designed to operate within. Operating above or below these levels will result in the unit either shutting down or reduced performance. The upper or lower limit should not be used as ideal room temperature levels. System reliability and product life expectancy will improve if temperature levels are maintained between 20 °C (68 °F) and 30 °C (86 °F).

#### Physical installation

The active filter is provided standard as a UL® chassis mount unit. The unit can be converted to a NEMA® 1 with an optional conversion kit. The following table describes each type.

**Table 1. Active filter**

Enclosure type	NEMA 2 IP31	NEMA 12 IP54
Enclosure provided	Yes	Yes
Standard compliance: UL 508	Yes	Yes
Standard compliance: IEC 529	Yes	Yes
Unrestricted air exchange, protection against contact with enclosed parts, protection against limited amount of falling dirt, intake of dust, and harmful particles	Yes	Yes
Protection against foreign bodies of these diameters	Yes >2.5 mm	Yes >1 mm
Complete protection against touch and protection against dust deposits	No	Yes
Protection against dripping water and external condensation of non-corrosive liquids	Yes	Yes
Protection against water from all directions	No	Yes

**Note:** This list indicates minimum requirements. Complete descriptions of the requirements are provided in the standards referenced in this list.

## Standard units physical description

**Table 2. NEMA 2, NEMA 12, IP31, and IP54 enclosure physical specifications**

Active filter	Cable entry	Operating temperature	Heat load (kW)	Weight kg (lb)	Exterior dimensions H x W x D mm (inches)
60 A	Top or bottom	0–40 °C (32–104 °F)	1.3	277 (609)	2089 x 800 x 555 (82.24 x 31.50 x 21.85)
120 A	Top or bottom	0–40 °C (32–104 °F)	2.8	287 (631)	2089 x 800 x 555 (82.24 x 31.50 x 21.85)
200 A	Top or bottom	0–40 °C (32–104 °F)	5.4	397 (873)	2091 x 900 x 650 (82.32 x 35.43 x 25.60)
300 A	Top or bottom	0–40 °C (32–104 °F)	7.1	422 (928)	2091 x 900 x 650 (82.32 x 35.43 x 25.60)

#### Note:

- Weight information is approximate and subject to change without notice

**Dimensional drawings**

Refer to the drawings on the following pages for dimensions of the active filter to be installed.

Floor mount 60 A and 120 A drawings

**Figure 1. 60 A and 120 A, 380–480 V, NEMA 2, NEMA 12, IP31 and IP54 units—dimensions in inches (mm)**

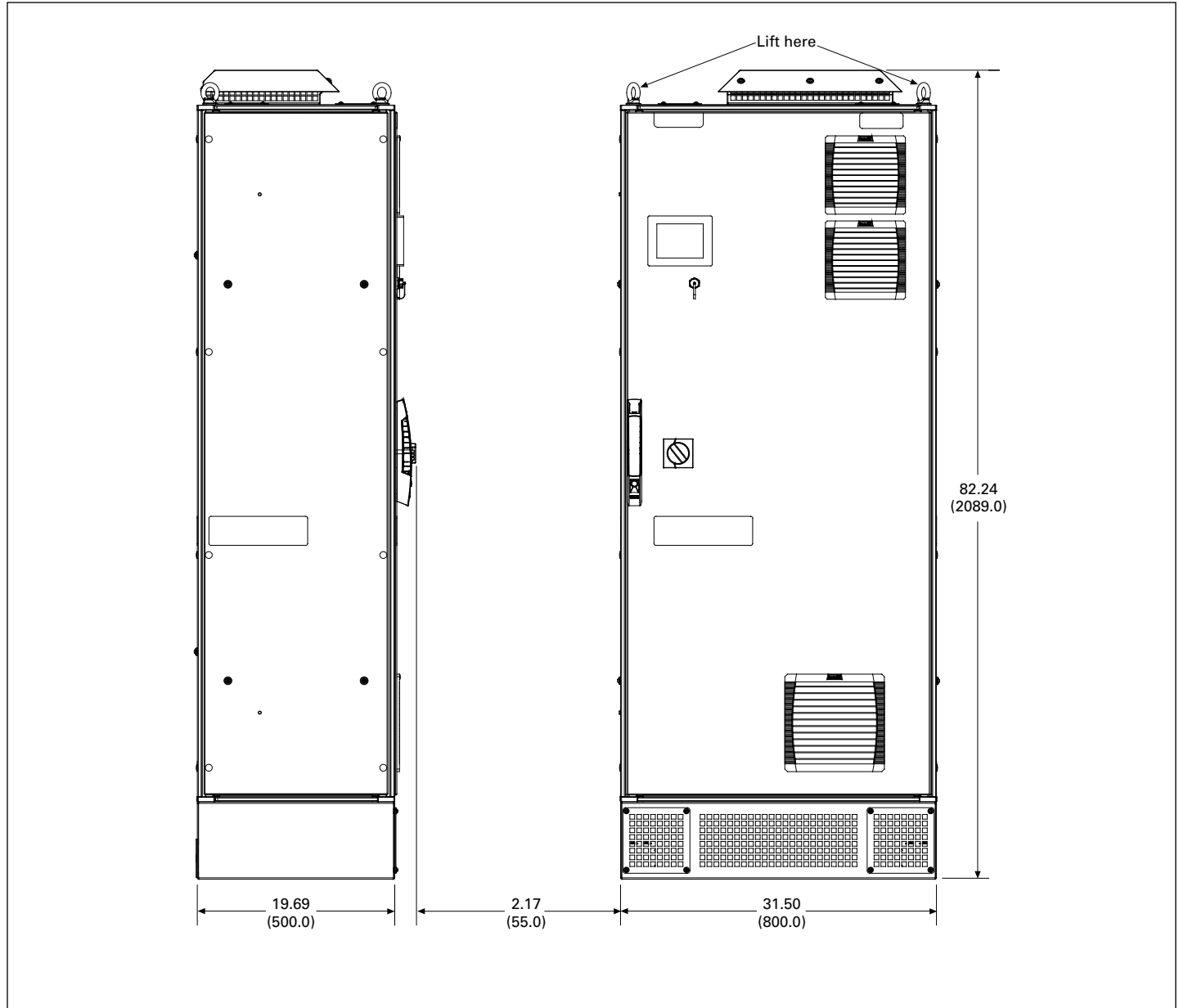
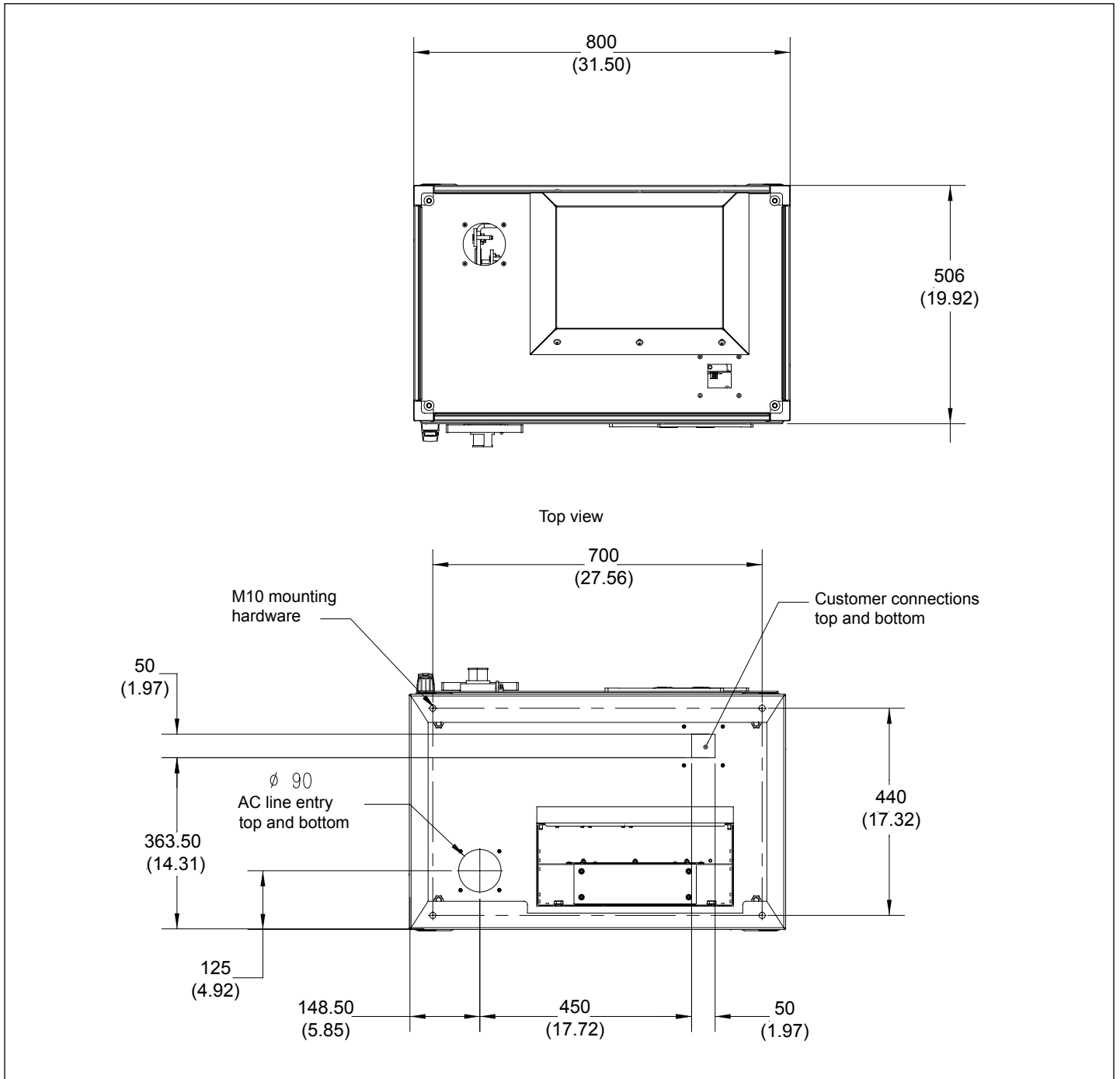


Figure 2. 60 A and 120 A enclosure top and bottom dimensional drawing in mm (inches)



200 A and 300 A drawings

Figure 3. 200 A and 300 A, 380–480 V, NEMA 2, NEMA 12, IP31 and IP54 units in inches (mm)

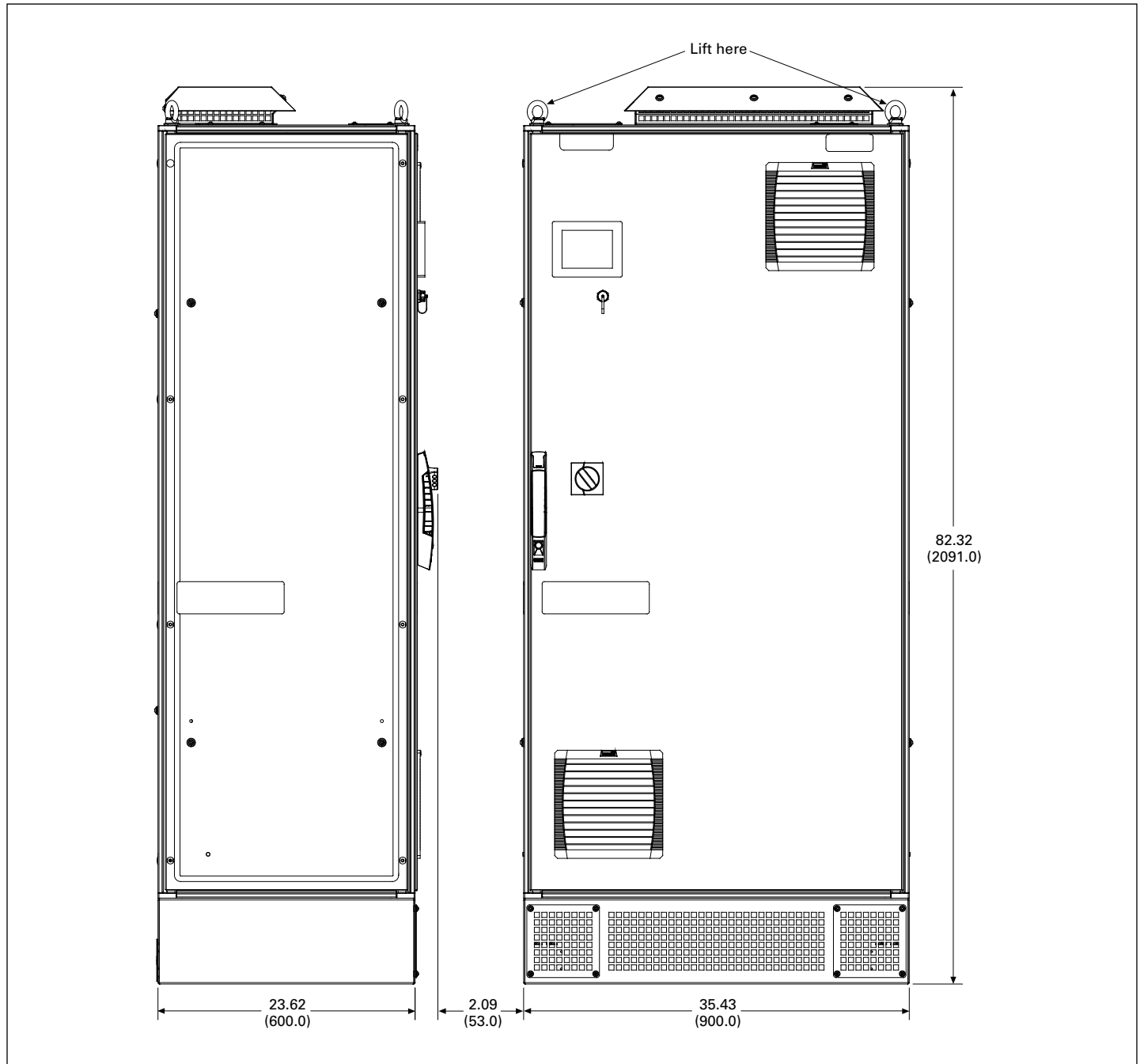
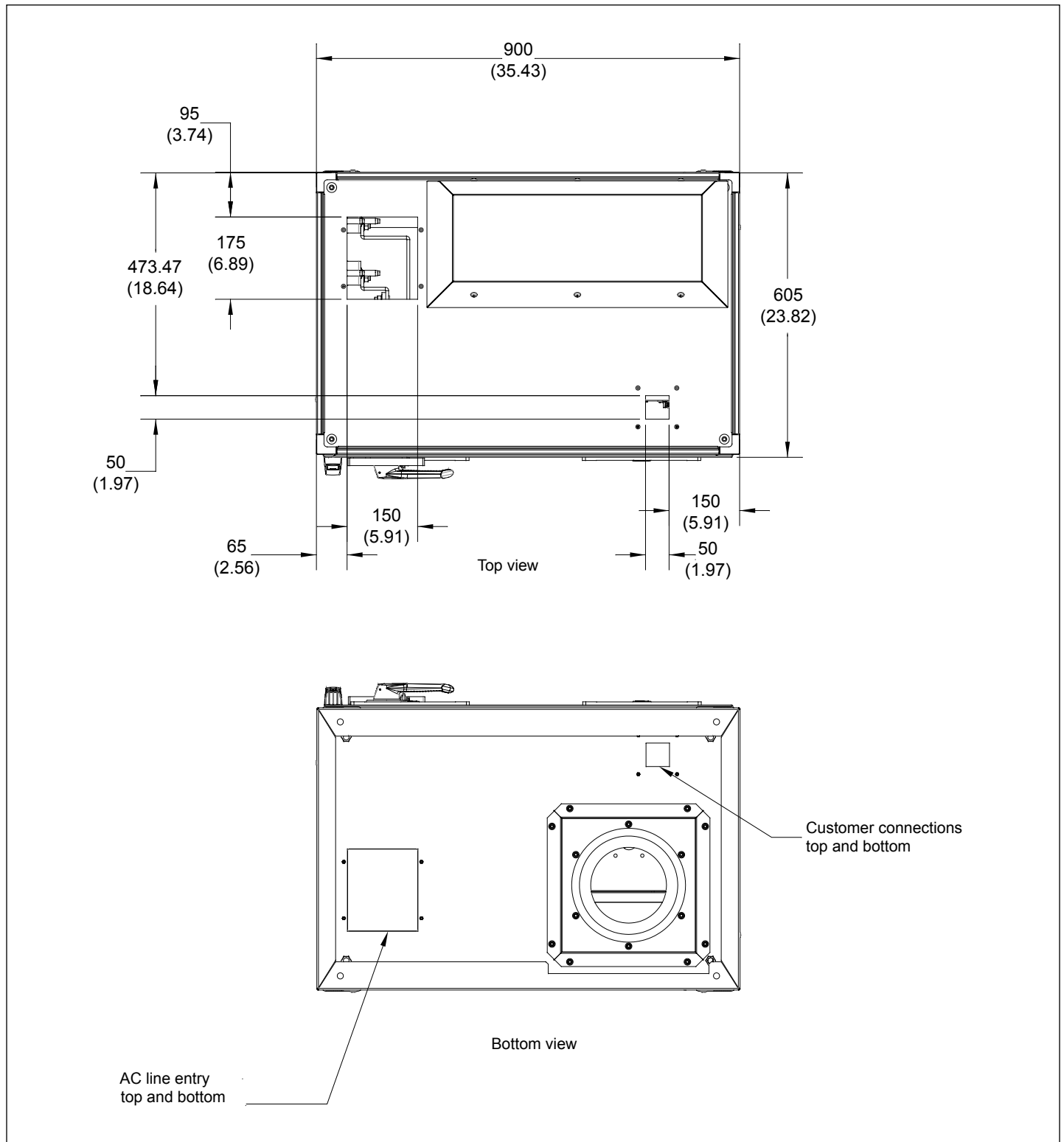




Figure 4. 200 A and 300 A enclosure top and bottom dimensional drawing in mm (inches)



**Attaching the enclosure to the floor**

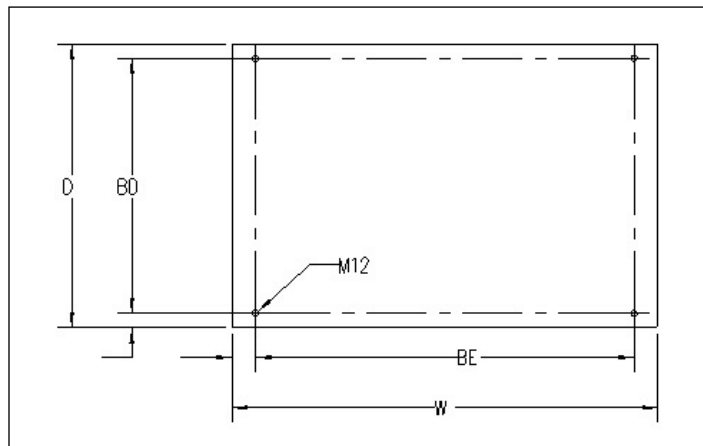
The unit must be securely attached to the floor where it is installed. There are four holes at the bottom of the plinth for securing the enclosure. Use M12 size hardware (not included).

**WARNING**

**RISK OF THE ENCLOSURE FALLING.**

**Attach the equipment to the floor using the attachment points indicated below. Failure to follow these instructions can result in death, serious injury, or equipment damage.**

**Figure 5. Floor attachment point locations**



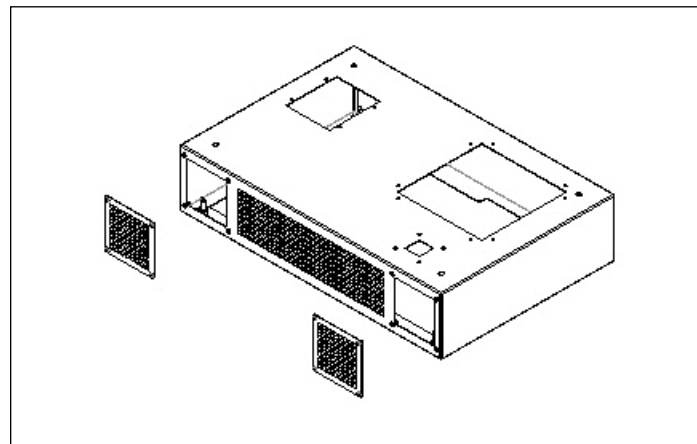
**Table 3. Dimensions in mm (inches)**

Ampere rating	D	W	BD	BE
60 A 120 A	500 (19.69)	800 (31.50)	440 (17.32)	700 (27.56)
200 A 300 A	600 (23.62)	900 (35.43)	540 (21.26)	800 (31.50)

Refer to **Figure 5** and **Table 3** for the dimensions and attachment locations for the enclosure you are installing and follow these steps:

1. Ensure that the location is large enough for the enclosure. Refer to the dimensions D and W for the enclosure you are installing.
2. Drill holes in the locations for the unit you are installing. Refer to dimensions BD and BE.
3. Position the equipment in its location.
4. Remove the two plinth access covers at the front of the plinth by loosening the four M6 screws using a T30 driver. See **Figure 6**.
5. Secure the unit to the floor using mounting hardware.
6. Replace the front access covers and torque the screws to 5.7 N•m (50.4 lb-in).

**Figure 6. Plinth access covers**



**Electrical connection**

**Line voltage**

Refer to **Table 5** on **page 11** to determine the line voltage that is compatible with the voltage range of the active filter.

**Circuit breaker and manual disconnect selection**

A dedicated overcurrent protection device, circuit breaker, or fuse disconnect is required for this product. The overcurrent protection device must be rated for at least 125% of the unit rating.

The active filter inrush current does not exceed the unit rating shown in **Table 4**. Circuit breaker settings such as Long Time Pickup, Long Time Delay, and Short Time Pickup can be set for minimum inrush current.

**Table 4. Unit ratings**

Unit rating	Minimum circuit ampacity	Minimum allowable fuse/circuit breaker size	Maximum allowable fuse/circuit breaker size
60 A	60 A	75 A	100 A
120 A	120 A	150 A	150 A (UL) / 160 A (IEC)
200 A	200 A	250 A	250 A
300 A	300 A	400 A	400 A

**Note:** Check national and local codes and regulations to ensure compliance.

### Power cable routing

Power cables connected to the active filter must be placed in metal conduit or be shielded encapsulated cables to reduce noise coupling (EMI). Entry for all power cables has to be made through the removable gland plates on the bottom or top of the active filter enclosure.

See **Figure 2** on **page 7** and **Figure 4** on **page 9**.

For all power systems, observe the following:

- Metal conduit or the encapsulated cable shield has to be grounded to the active filter ground-terminal located adjacent to the power terminals
- All panels must be installed to ensure proper system cooling

## NOTICE

### Risk of contamination by conductive material or debris.

Remove conduit entry gland plates to drill cable entry holes.

### Failure to follow this instruction can result in equipment damage.

The active filter warranty is void if operational difficulties are found to be caused by metal particles from the installation process.

### Power and ground cable selection and connections



**DANGER**

### Hazard of electric shock, explosion, or arc flash.

Ground equipment using the ground connecting point provided before turning on any power supplying this device.

### Failure to follow these instructions will result in death or serious injury.

All power wiring has to be routed directly from the conduit entry plate to the terminations on power terminals (and the earth grounding terminal) without loops. Instrumentation and CT wiring has to be routed in a separate grounded metal conduit or shielded encapsulated cable. A dedicated ground conductor must be used when installing the active filter.

When used as a harmonic current compensation device, the active filter produces currents at frequencies that are multiples of the AC line fundamental frequency. Power cables as well as input disconnect devices should be rated at 125% of the active filter rated current. This helps avoid excessive heating from any skin effect resistance increase at these higher frequencies.

**Note:** Check national and local codes and regulations to ensure compliance.

M8 power and ground studs are provided for the 60 A and 120 A rated units. M12 power and M8 ground studs are provided for the 200 A and 300 A units. The busbar for power connection has two studs that can accept either a two-hole crimp lug or a two-hole box lug. The 60 A and 120 A units' busbar studs are 25.4 mm (1 in) apart center-to-center. See **Figure 2** on **page 7** for details. The 200 A and 300 A units busbar studs are 44.5 mm (1.75 in) apart center-to-center. See **Figure 4** on **page 9** for details.

Box lugs are not IEC compliant. For IEC installation, use crimp-on ring lugs for electrical connections.

**Table 5. Electrical specifications 60, 120, 200, and 300 A units**

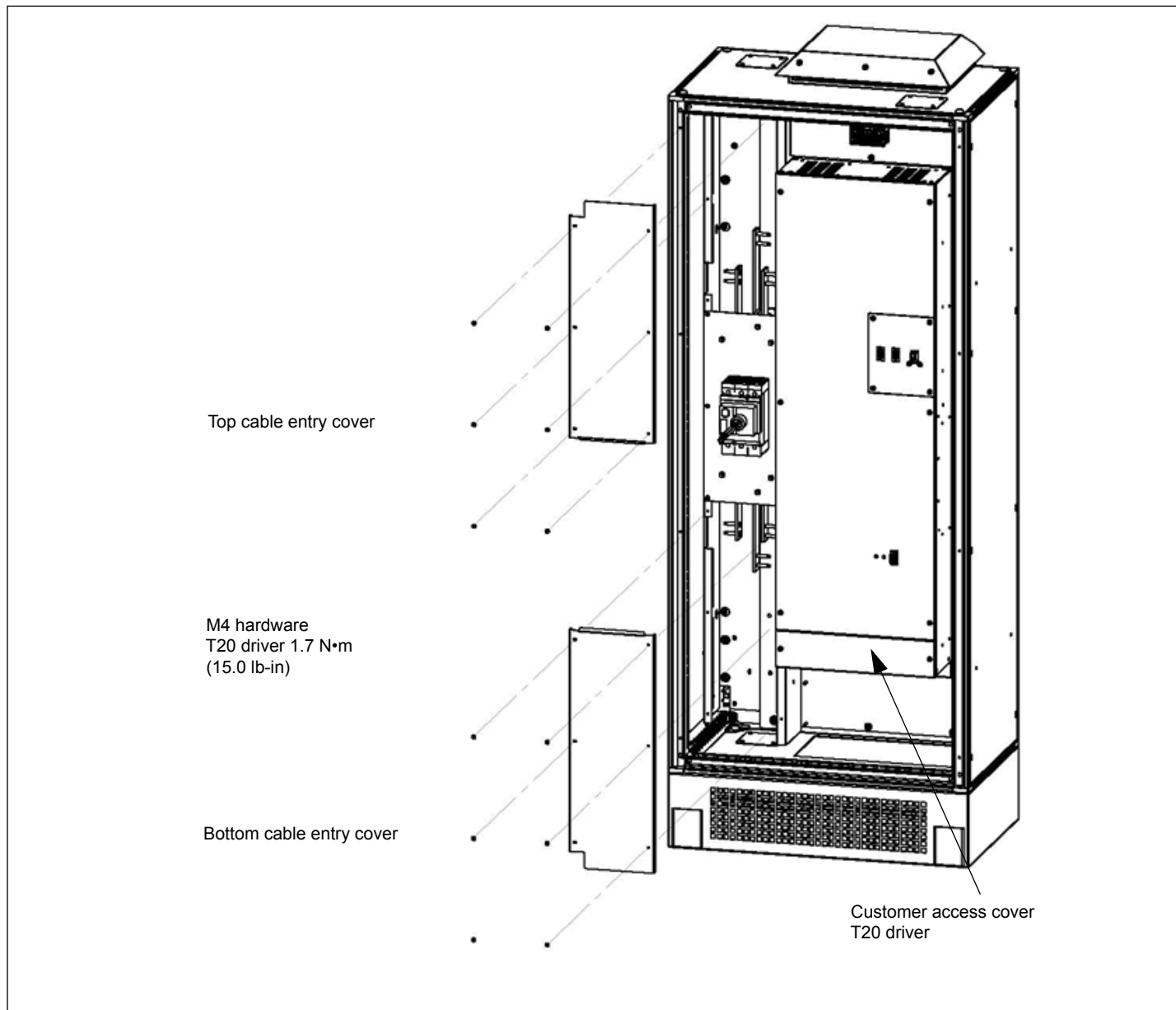
Active filter	Total current (A)	Voltage range (V)	Frequency Hz	Wire temperature rating	Intake air temperature	Power connection stud size and torque N•m (lb-in) ±5%	Ground connection stud size and torque N•m (lb-in) ±5%	Number of conductors per phase
60 A Enclosures N2, N12, IP31, IP54	60	380–480	50 or 60 Hz ±3 Hz	60 °C, 75 °C, 90 °C	0–40 °C (32–104 °F)	M8 stud–18.2 (161.1)	M8 stud–18.2 (161.1)	1
120 A Enclosures N2, N12, IP31, IP54	120	380–480	50 or 60 Hz ±3 Hz	75 °C, 90 °C	0–40 °C (32–104 °F)	M8 stud–18.2 (161.1)	M8 stud–18.2 (161.1)	1
200 A Enclosures N2, N12, IP31, IP54, and chassis	200	380–480	50 or 60 Hz ±3 Hz	75 °C, 90 °C	0–40 °C (32–104 °F)	M12 stud–37.0 (327.5)	M8 stud–18.2 (161.1)	1 or 2
300 A Enclosures N2, N12, IP31, IP54	300	380–480	50 or 60 Hz ±3 Hz	75 °C, 90 °C	0–40 °C (32–104 °F)	M12 stud–37.0 (327.5)	M8 stud–18.2 (161.1)	1 or 2

**Notes:**

- Check national and local codes and regulations to ensure compliance.
- The active filter generates significant heat during operation. Ensure that the room where the active filter is located has adequate ventilation to maintain intake air temperature within the specified operating range.

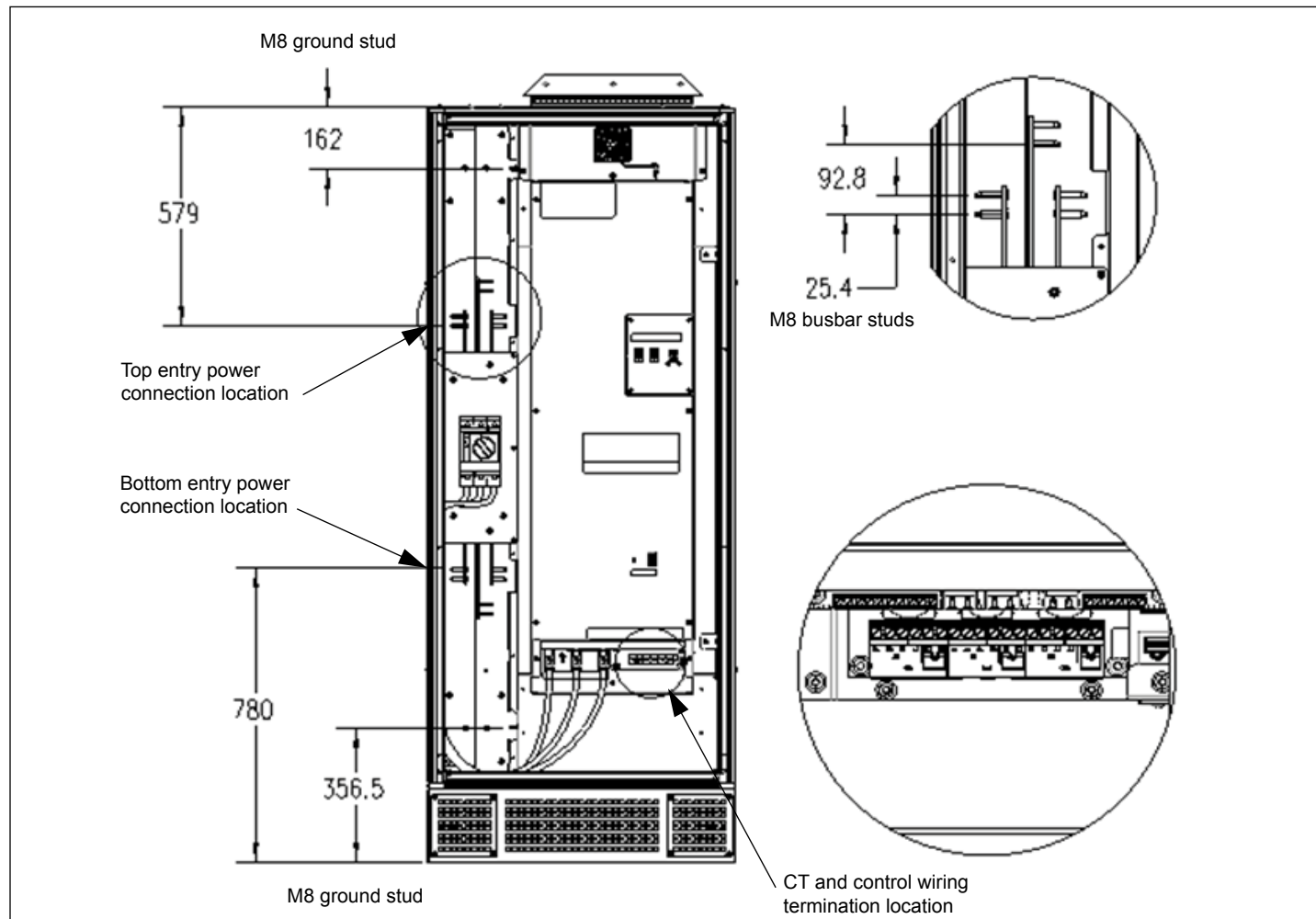
Power termination covers

Figure 7. Power termination covers



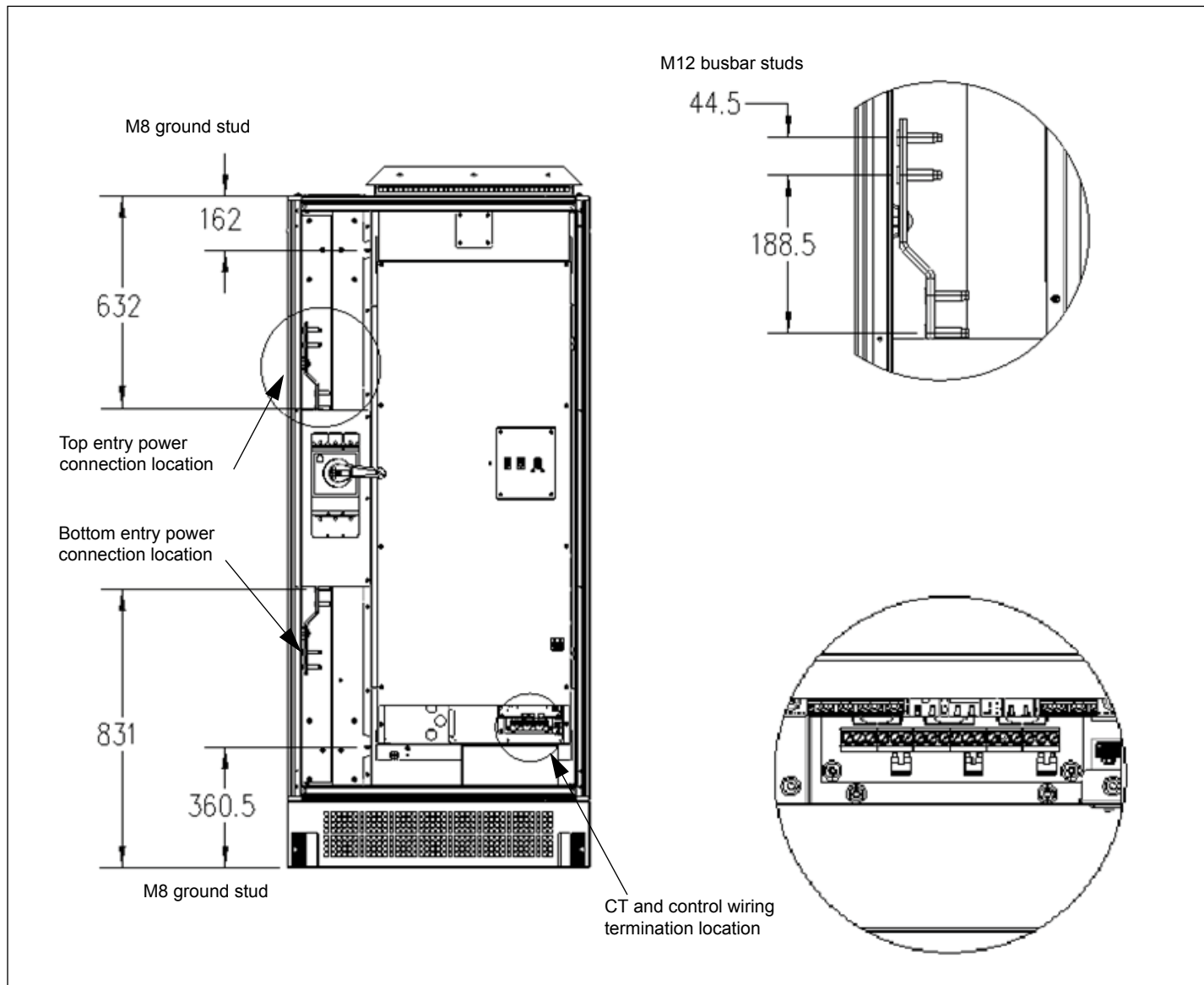
60 A and 120 A models

Figure 8. 60 A and 120 A enclosure internal layout drawing



200 A and 300 A models

Figure 9. 200 A and 300 A enclosure internal layout drawing



**Current transformers (CTs)**

**⚠ WARNING**

**Hazard of electric shock, explosion, or arc flash.**

- Apply appropriate personal protective equipment (PPE) and follow safe electrical work practices. See NFPA 70E in the USA, CSA Z462, or applicable local standards
- This equipment must be installed and serviced only by qualified electrical personnel
- Do not exceed the device’s ratings for maximum limits
- Ground equipment using the ground connecting point provided before turning on any power supplying this device
- Turn off all power supplying this device and the equipment in which it is installed before working on the device or equipment
- After removing power, wait for 15 minutes to allow the capacitors to discharge prior to opening the doors or removing covers

- Always use a properly rated voltage sensing device to confirm power is off
- Replace all devices, doors, and covers before turning on power to this equipment
- Carefully inspect the interior for tools left behind before closing and sealing the door

**Failure to follow these instructions will result in death or serious injury.**

Ensure that CT secondary current is not present when wiring the CT secondary connections. The shorting jumpers must be installed at the X1 to X2 OUT of each CT channel on the CT board unless you are connecting an additional Master parallel unit. Refer to **Figure 11** on **page 17**.

### General CT information

The CT must be orientated properly during installation. The orientation is specified in the drawings with an arrow indicating the direction or polarity of the CT. Most CT manufacturers will indicate orientation with a label indicating H1 on one side of the CT or a dot. There can also be a label indicating H2 and/or an arrow on the CT. The H1 side of the CT should always be closest to the power source. If the CT has an orientation arrow, it should point from the source towards the load. See the installation instructions for the specific CTs being installed.

A shorting terminal block or shorting switch with galvanic isolation to the active filter for the CT secondary is recommended. Insert an interposing terminal block in a separate enclosure with the ability to short the secondary wiring of the CT. CT shorting blocks provide the ability to short the CTs without entering the active filter enclosure (which otherwise would require a power shutdown). CT shorting terminal blocks are available in the catalog. A four-pole shorting block, Eaton part number TXSB is available as a separate sale item.

CT location is defined in relationship to the active filter system. CT location on the “Source Side” indicates that the CTs are physically located upstream of the active filter. The CTs will measure the improvement to the current as a result of the active filter operating. A CT location on the “Load Side” indicates that the CTs are downstream of the active filter. The CTs will monitor the load current provided by both the source and active filter currents.

For applications where the harmonic correction unit is being used in conjunction with power factor correction capacitors, please contact Eaton’s Technical Resource Center for additional current transformer configuration requirements.

---

## NOTICE

---

### Measurement errors.

CTs must be physically separated from any perpendicular conductor by at least 25 mm (1 inch) for every 1000 A of current flowing through the perpendicular conductor.

### Failure to follow this instruction can result in a reduction in performance of the active filter.

If this practice is not followed, the magnetic field produced by the current flowing on the perpendicular conductor will cause CT measurement errors.

### Minimum CT requirements

The active filter uses a minimum of two external current transformers (CTs) to measure load current waveforms. The CTs should be mounted on phases L1 and L2 with H1 facing the source. Systems that are using two CTs can have the CTs installed on L1 and L3 or L2 and L3 if necessary. If L1 and L3 or L2 and L3 CT configurations are used, this information must be provided to the qualified person commissioning the unit. Three external CTs are required if line-to-neutral connected loads are present.

---

## NOTICE

---

### Reduced performance.

CT wiring must be routed separately from power cables.

### Failure to follow this instruction can result in a reduction in performance.

CT wiring must be routed directly from the conduit entry-plate to the terminal block of the CT board.

CT must be selected for:

- 5 A secondary
- 250 to 10,000 primary rating
- 50/60 Hz or 400 Hz rated

- The CT shall be metering class, primary rating as required, 5 A secondary rating. The minimum Burden designation is B-0.5, as defined in IEEE® Standard C57.13-2008
- The CT primary current rating must exceed the maximum load current where they are installed
- The maximum burden (in VA) on the CT is formed by the CT wiring and total active filter burden. This is equal to 1.0 VA for CTs with a 5 A secondary rating or 0.04 VA for CTs with a 1 A secondary rating
- Wire size of the CT should be 4 mm<sup>2</sup> (12 AWG) or 6 mm<sup>2</sup> (10 AWG). Consult the CT manufacturer for secondary wiring recommendations. See **Table 6** and **Table 7** on **page 16** for adding wire to CT secondary wiring

CT secondary wiring must be either twisted and/or shielded pairs

Do not connect the active filter CT to any other loads. Use a separate current transformer if additional uses are required.

Any splicing to the CT leads needs to be done with CT shorting blocks. A four-pole shorting block, Eaton part number TXSB, is available as a separate sale item.

Tap 2 of each CT installed must be grounded as close to the CT as possible. Tap 2 is the higher of the two CT secondary terminals being used. For multi-ratio CTs, Tap 2 may be a terminal other than X2. For example, if CT secondary terminals X1 and X5 are used to obtain the desired CT ratio, X5 is Tap 2.

A single active filter, not operating in parallel, can have the CTs installed either on the source side or load side of the active filter. Parallel systems must have the main CTs installed on the source side of the active filter system.

### CT to CT board connection

The CT connection is made behind the small customer access panel at the bottom of the active filter chassis. See **Figure 7** on **page 12**. Remove the customer access panel. The CT board is located behind and slightly below the control board. This is the location where the active filter CT secondary wiring must be terminated. Remove the clear plastic safety cover to access the CT board.

Typically, L1 CT will be connected to CH1 IN. There are two X1 and X2 IN terminals. The second set of IN terminals can be used to connect additional CTs that may be required for site specific conditions. X1 and X2 OUT are used for parallel active filter systems.

The terminal block on the CT board can accept wire sizes of up to 6 mm<sup>2</sup> (10 AWG) wire and has a torque specification of 1 N·m (9 lb-in).

---

## NOTICE

---

### Circulating currents.

When using shielded CT secondary wire, only ground the shield at one end of the cable.

### Failure to follow this instruction can result in a reduction in performance.

---

## NOTICE

---

### Inaccurate filter operation.

Do not allow the conductor on which the CT is mounted to become lodged in the joint area of a split-core CT.

### Failure to follow this instruction can result in inaccurate filter operation.

Figure 10. Control board and CT board detail

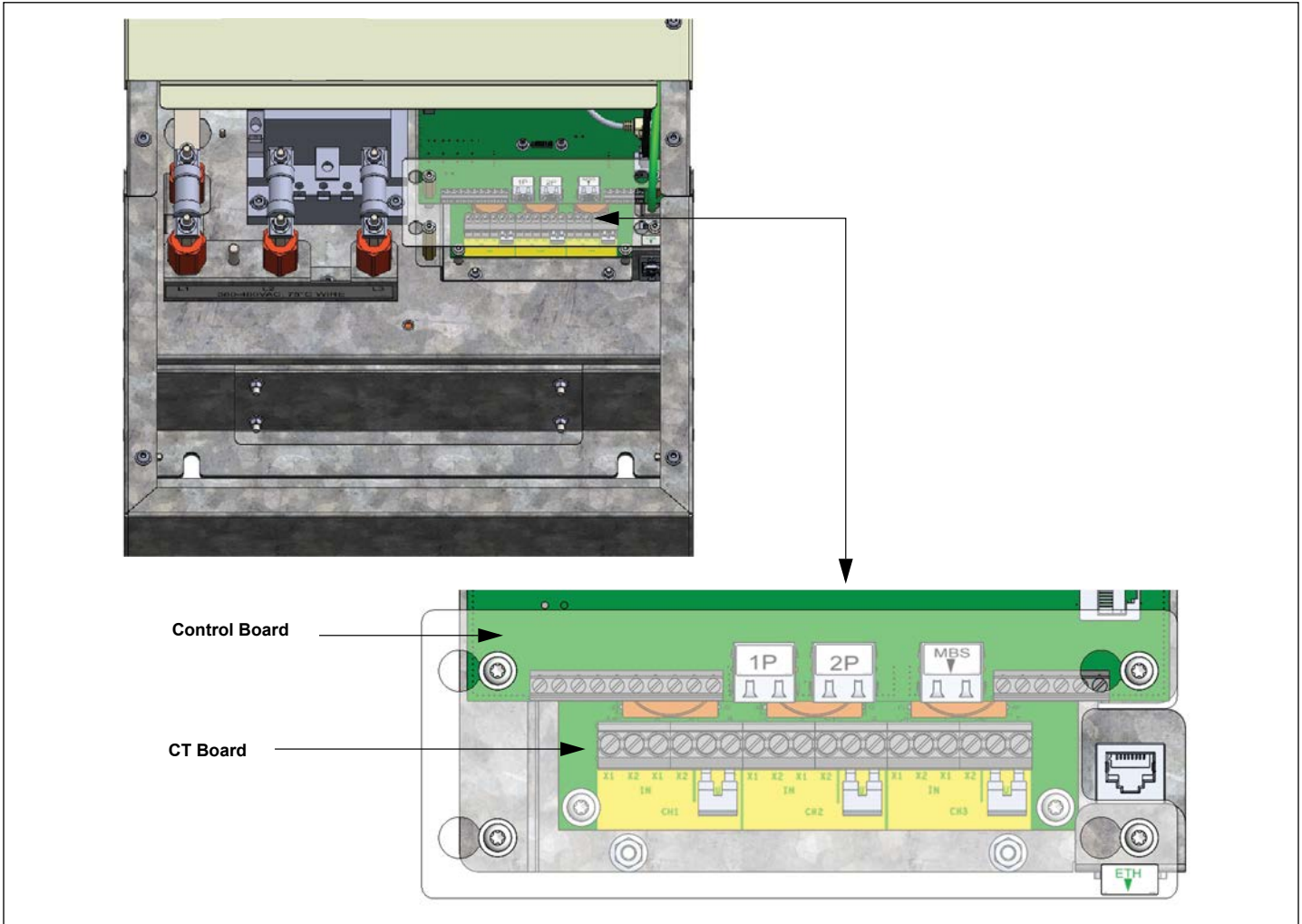


Table 6. 5 A secondary maximum wire length

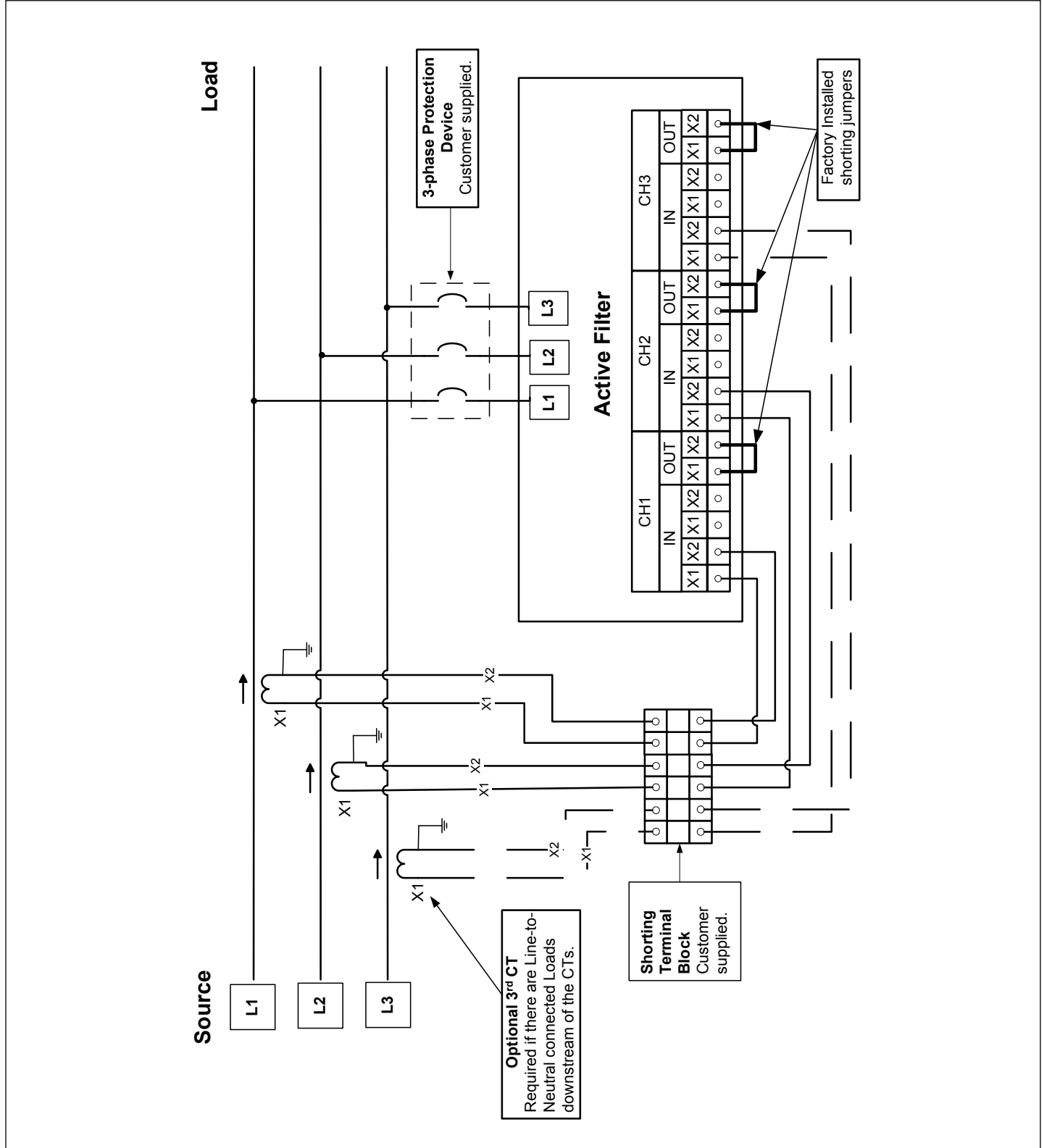
CTs burden capacity with 5 A secondary	Maximum wire length from active filter to CT in meters (feet)	
	4 mm <sup>2</sup> (12 AWG)	6 mm <sup>2</sup> (10 AWG)
5 VA	7 (24)	12 (41)
15 VA	38 (124)	63 (208)
25 VA	68 (224)	114 (375)
30 VA	83 (273)	139 (457)
35 VA	99 (324)	165 (541)
45 VA	129 (423)	216 (708)

Table 7. 1 A secondary maximum wire length

CTs burden capacity with 1 A secondary	Maximum wire length from active filter to CT in meters (feet)	
	4 mm <sup>2</sup> (12 AWG)	6 mm <sup>2</sup> (10 AWG)
5 VA	373 (1223)	623 (2043)
15 VA	1135 (3724)	1895 (6215)
25 VA	1897 (6223)	3167 (10,387)
30 VA	2278 (7473)	3804 (12,477)
35 VA	2660 (7412)	4440 (14,563)
45 VA	3422 (11,224)	5712 (18,735)

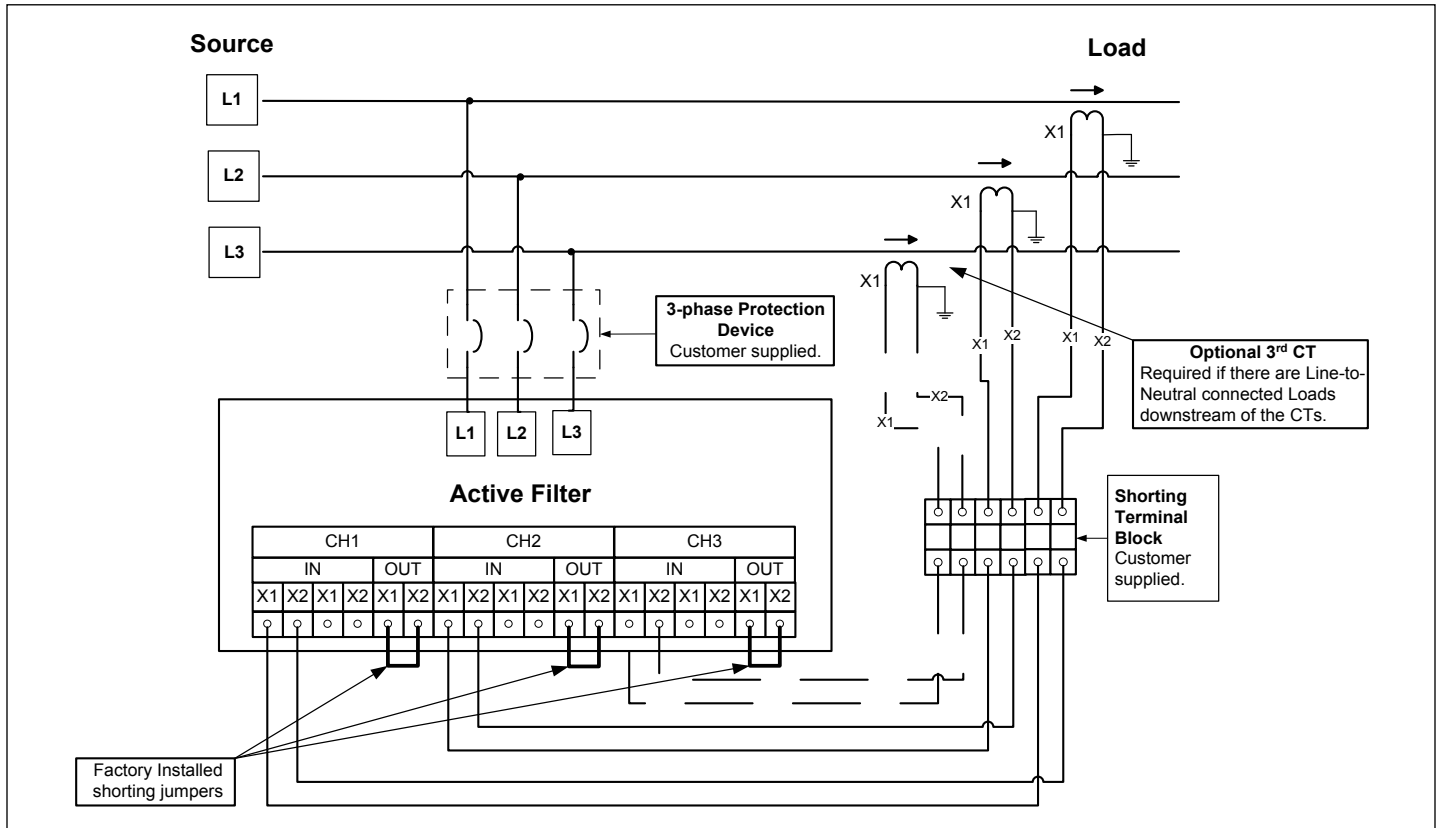


**Figure 11. Source side CT position diagram**  
(CTs installed on the “source side” or upstream of the active filter)



**Note:** The factory installed shorting jumpers must be installed.

**Figure 12. Load side CT position diagram**



**Note:** The factory installed shorting jumpers must be installed.

**Parallel system**

Up to ten active filters can be installed in parallel. If more than ten units in parallel are required, contact the local sales representative for assistance prior to installation.

**CT installation parallel units**



**WARNING**

**Hazard of electric shock, explosion, or arc flash.**

The factory provided shorting jumpers must be installed at the OUT of the CT board of the last unit with CT secondary wiring connected.

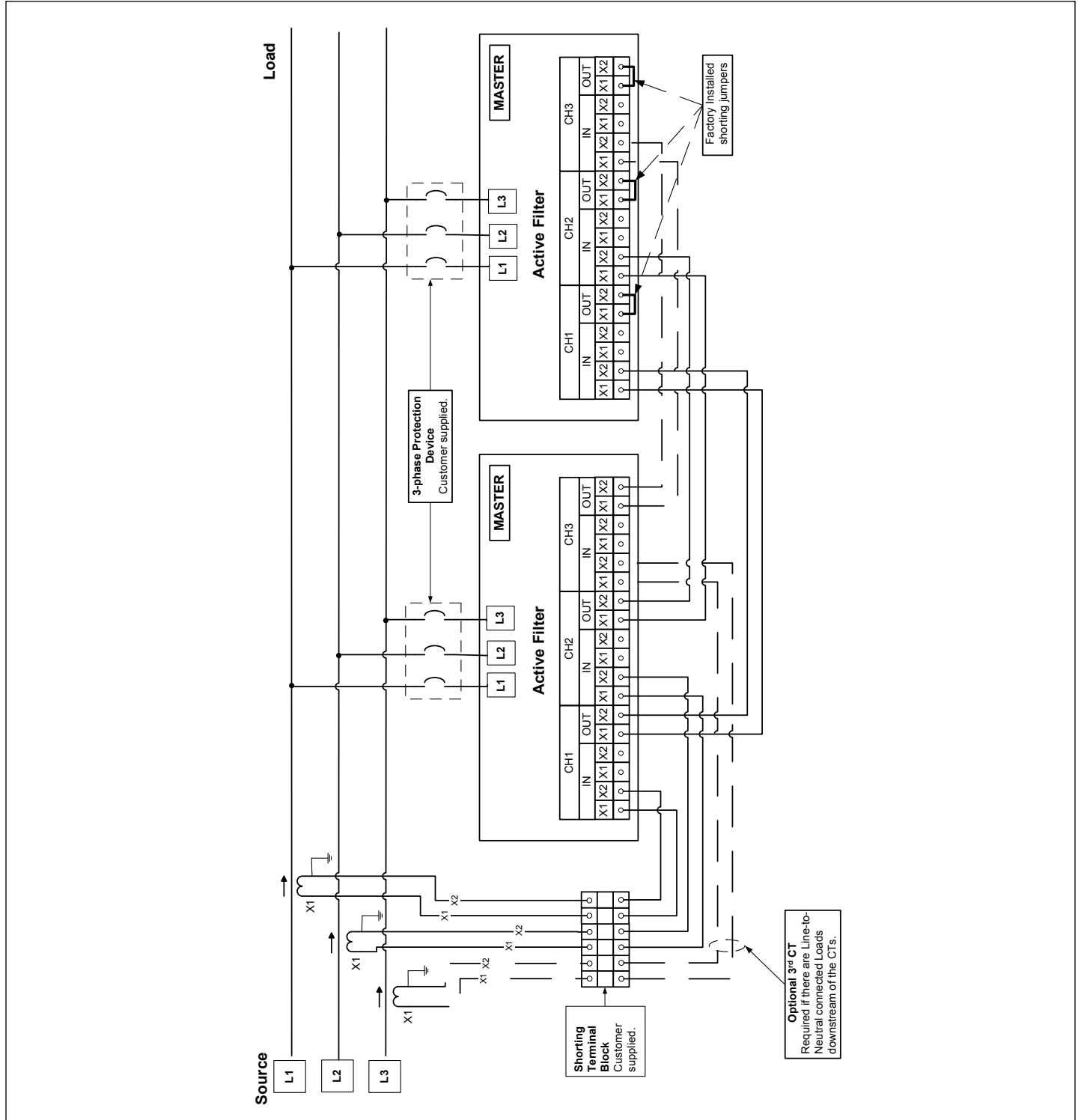
**Failure to follow these instructions will result in death or serious injury.**

The active filters can be set up to be either Master or Slave. To be a candidate as a Master, the unit must be provided with CT secondary wiring to the CT board. See **Figure 10** on **page 16**. There is no limit to the number of units that can be set up as a Master candidate. At least two units should be capable of being the Master in any parallel installation.

The main CTs must be installed on the source side of the active filter system. Examples of CT secondary wiring can be seen on the following pages in this section. Refer to **“Circuit breaker and manual disconnect selection”** on **page 10** for information on circuit breaker and fuses required.

Wiring diagrams

Figure 13. Source side CT position parallel units diagram



**Optional 3rd CT**  
Required if there are Line-to-Neutral connected Loads downstream of the CTs.

Figure 14. CT wiring for three masters

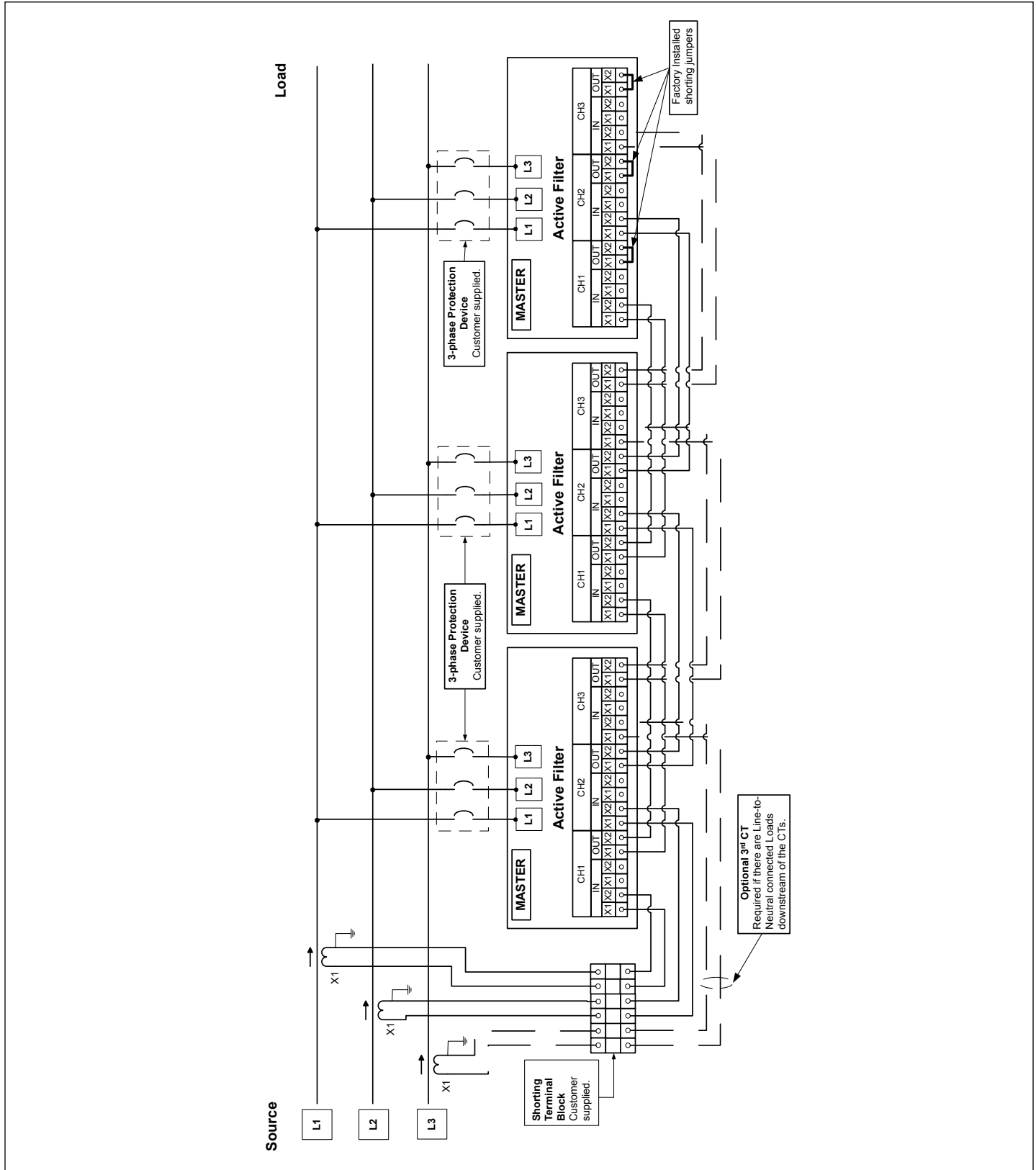


Figure 15. CT wiring for two masters and one slave

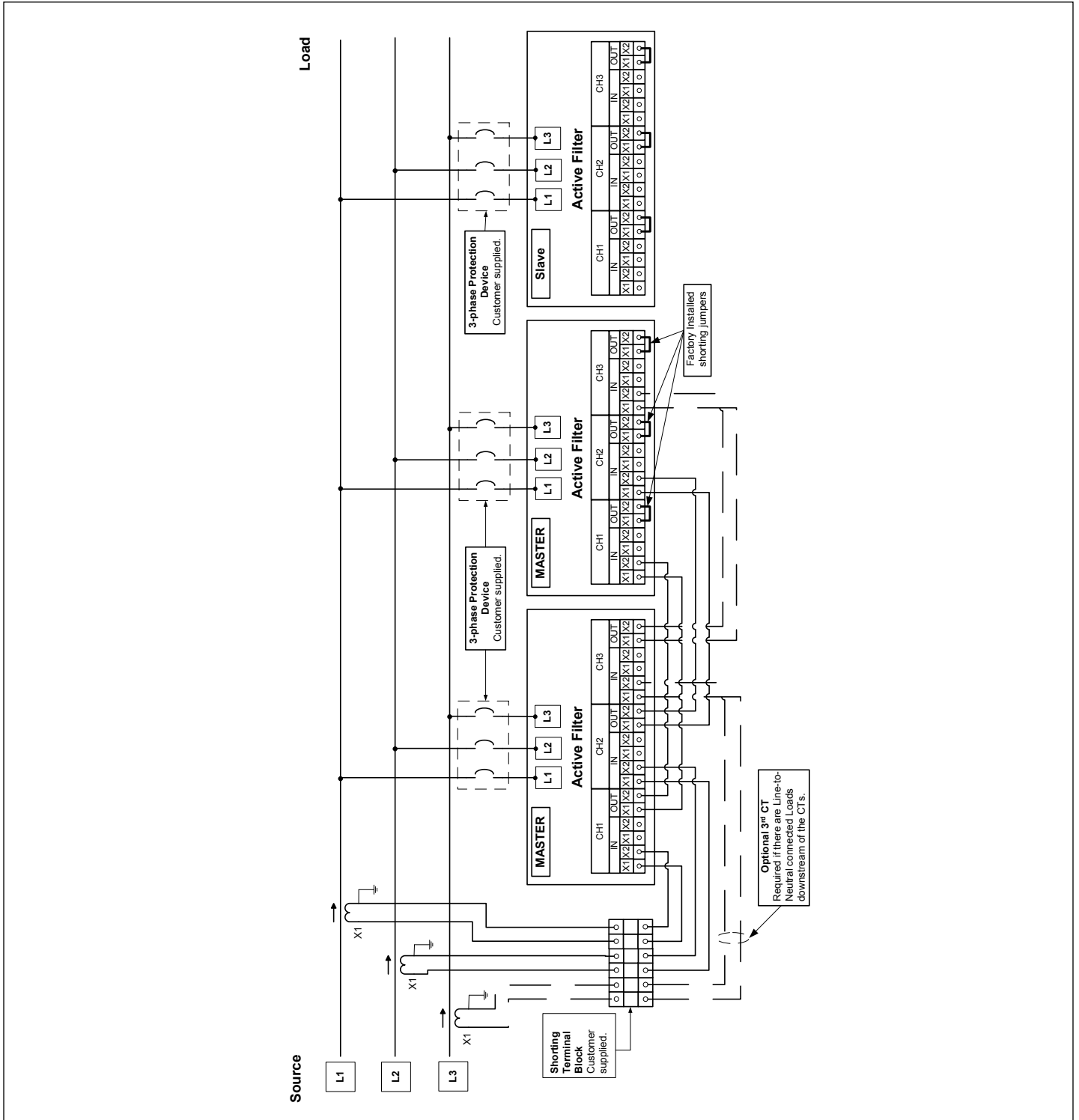
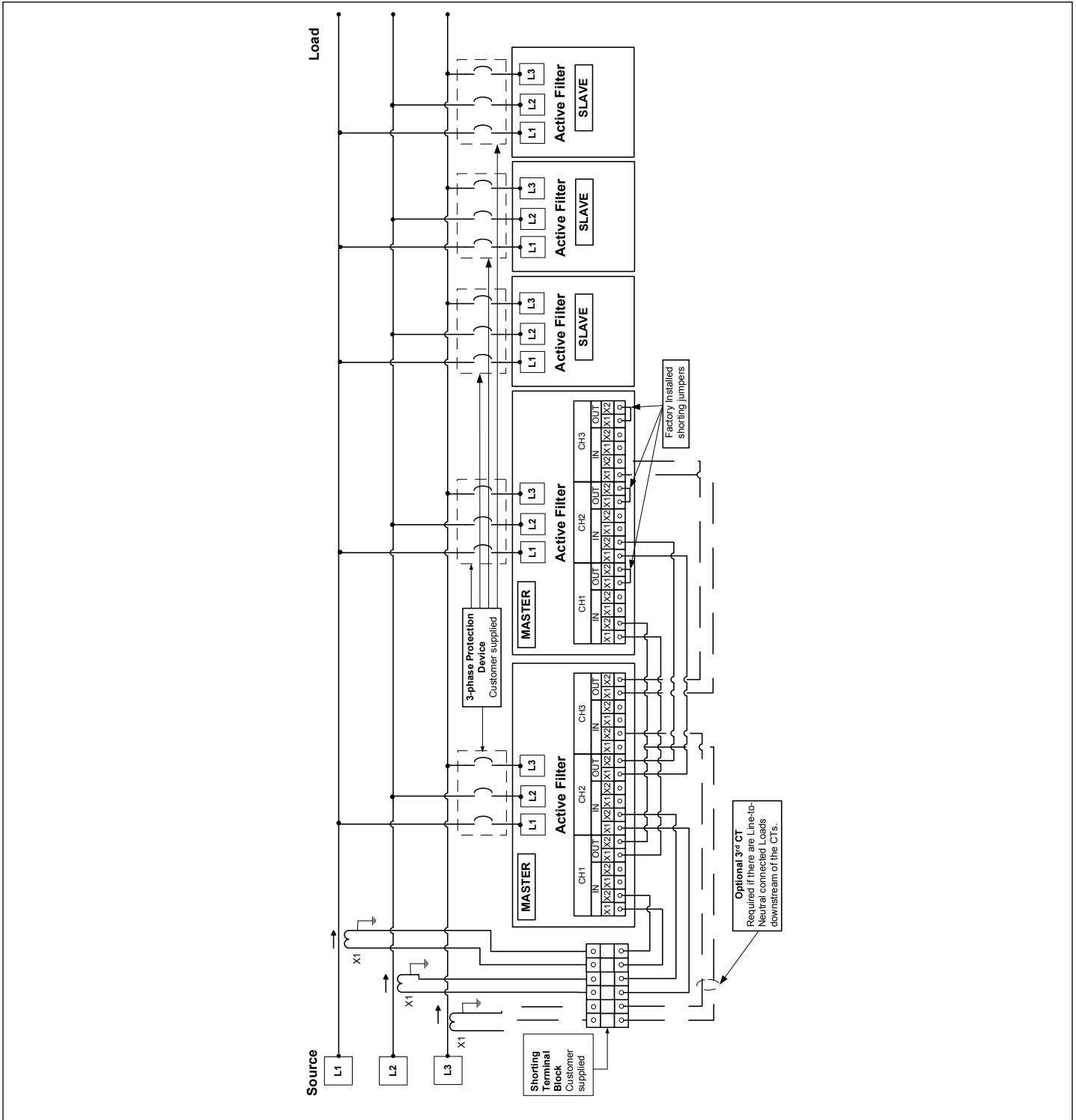


Figure 16. CT wiring for two masters and three slaves



**Parallel communication**

For parallel operation, the units communicate through the RJ-45 connectors labeled 1P and 2P on the Control Board. This is a unique communication protocol that is only to be used for parallel communication. The 2P jack has an RJ-45 termination plug installed at the factory.

CAT5e cable with all 8 conductors terminated at the RJ-45 connections is required for parallel communication. It is recommended that shielded CAT5e cable be used. Ensure that the total cable length does not exceed 76 meters (250 feet).

---

**NOTICE**

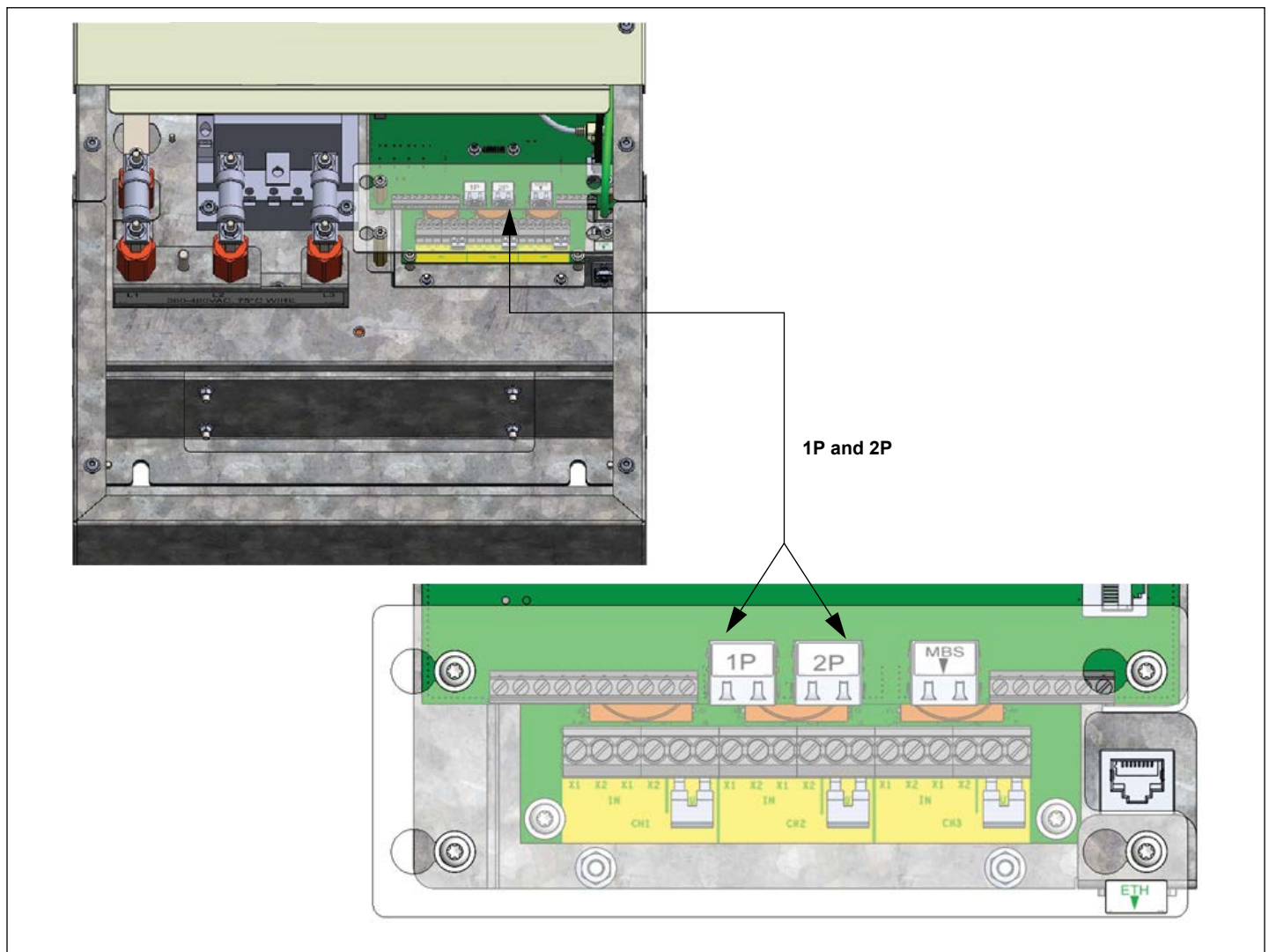
---

**Excessive noise in the communication circuit.**

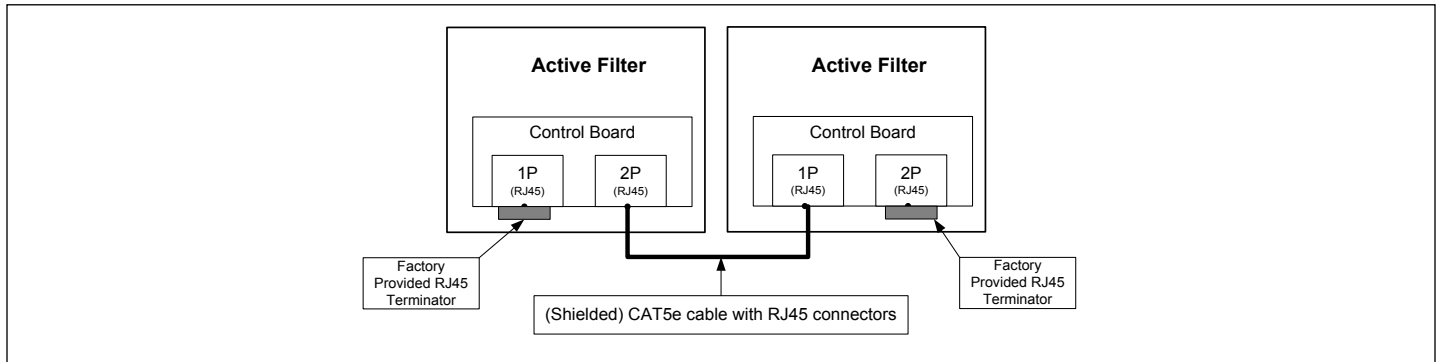
When the unit is set to operate in parallel mode, the termination plug must be installed in any RJ-45 jacks that are not used for parallel communication wiring. See the wiring diagrams in this section.

**Failure to follow this instruction can result in communication errors.**

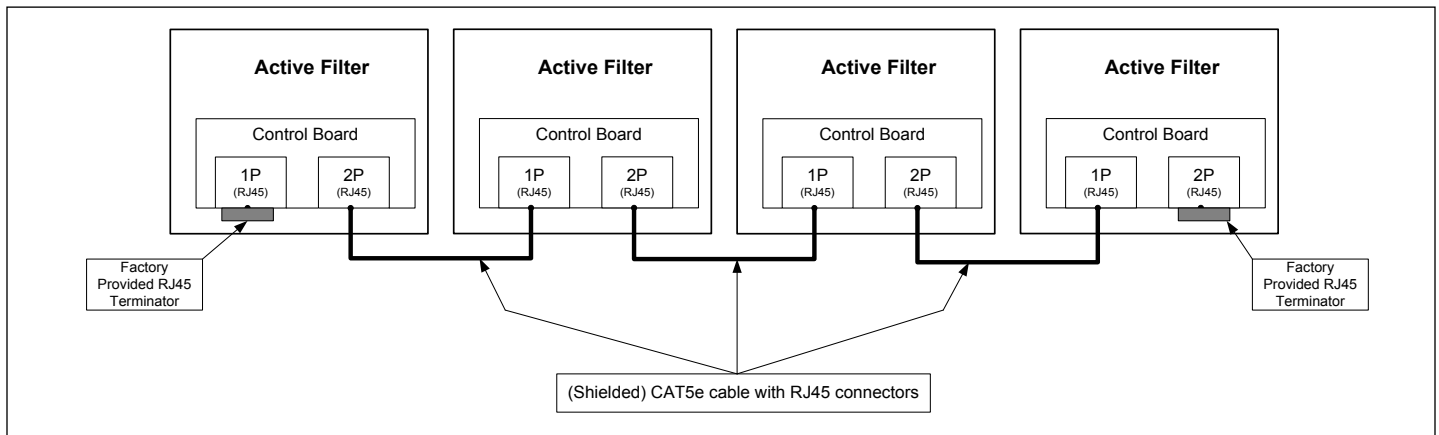
**Figure 17. Control board and CT board detail**



**Figure 18. Two unit parallel communication wiring diagram**



**Figure 19. Four unit parallel communication wiring diagram**



### Control wiring

#### Dry contact output

Four dry Contact outputs are available at J2 of the Control Board. See **Figure 10** on **page 16**. One common and four switchable outputs are available labeled Q1 to Q4. The four outputs can be programmed to change states on different conditions by the HMI and be set to either normally open or normally closed. See the User Manual for setting the output contacts. Maximum voltage accepted is 250 Vac or 30 Vdc with a 1 A maximum current.

#### Digital input control

Four input controls are available at J2 of the Control Board. See **Figure 10** on **page 16**. One Ground and four inputs labeled I1 to I4. The inputs are at 5 Vdc and are grounded to activate. The control function can be programmed by the HMI. See the User Manual for setting the functionality of the input control.

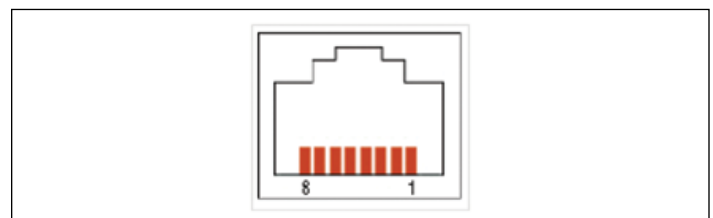
#### Modbus® TCP/IP

Modbus TCP/IP monitoring is available at the RJ-45 jack to the right of the control board labeled ETH. Refer to **Figure 10** on **page 16**. Modbus addresses are provided in the User Manual.

### Modbus Serial

A serial Modbus connection is available through an RJ-45 jack labeled MBS on the control board. Refer to **Figure 10** on **page 16**. Modbus addresses are provided in the User Manual.

**Figure 20. Serial Modbus pin-out**



**Table 8. Serial Modbus pin-out**

Pin	Signal name	Direction	Meaning
1	Not connected	—	—
2	Not connected	—	—
3	Not connected	—	—
4	D1	Input/output	Transfer data (RS-485)
5	D0	Input/output	Transfer data (RS-485)
6	Not connected	—	—
7	Not connected	—	—
8	SG	—	Signal ground



Figure 21. Control board and CT board detail

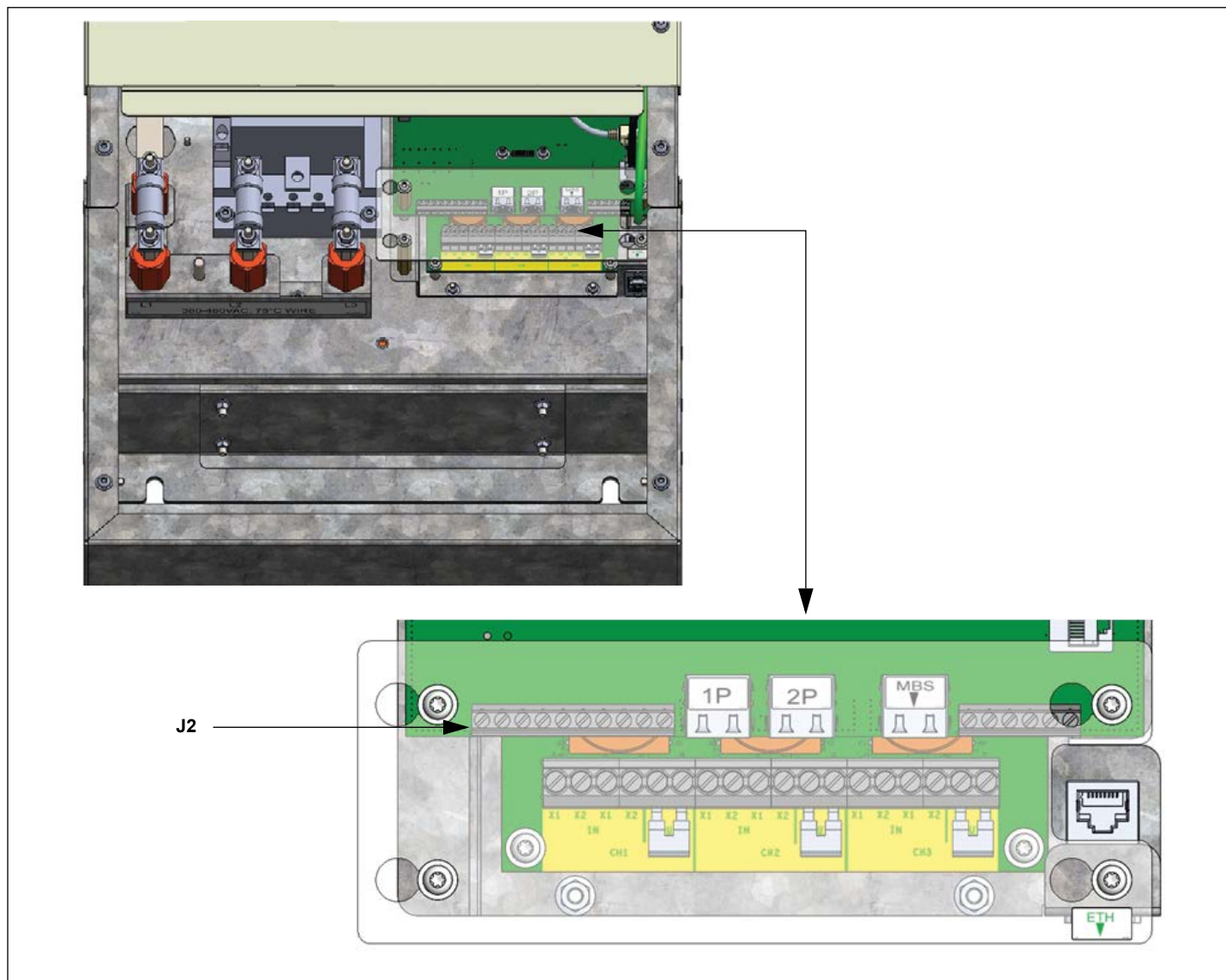
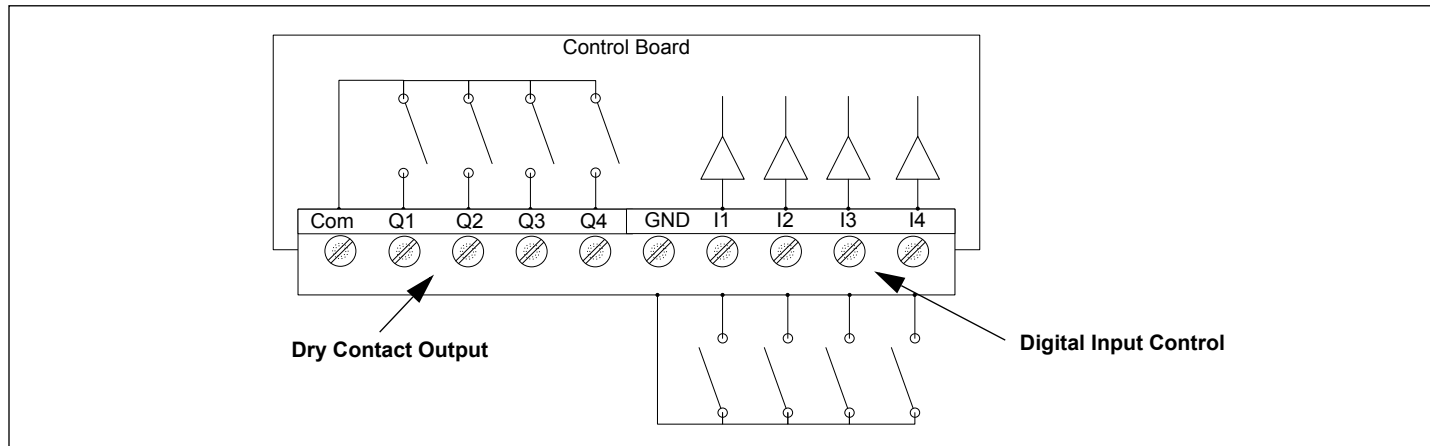


Figure 22. Control board J2 detail



## Pre-commissioning

This section provides information for preparation of the active filter for commissioning. Before applying power, read and understand this information thoroughly.

### Instruments required for commissioning

- Voltmeter or multimeter
- Clamp-on ammeter
- Megohmmeter

### Pre-energizing procedure

---

## WARNING

---

### Hazard of electric shock, explosion, or arc flash.

- Apply appropriate personal protective equipment (PPE) and follow safe electrical work practices. See NFPA 70E in the USA, CSA Z462, or applicable local standards
- This equipment must be installed and serviced only by qualified electrical personnel
- Do not exceed the device's ratings for maximum limits
- Ground equipment using the ground connecting point provided before turning on any power supplying this device
- Turn off all power supplying this device and the equipment in which it is installed before working on the device or equipment
- After removing power, wait for 15 minutes to allow the capacitors to discharge prior to opening the doors or removing covers
- Always use a properly rated voltage sensing device to confirm power is off
- Replace all devices, doors, and covers before turning on power to this equipment
- Carefully inspect the interior for tools left behind before closing and sealing the door

**Failure to follow these instructions will result in death or serious injury.**

### Installation inspection

Inspect all connections for both power and control wiring. Ensure that the correct termination points have been made for each wire. Ensure that all connections are firmly tightened prior to start-up.

### Pre-commissioning checklist

Prior to commissioning the active filter system, the following items must be completed:

- Electrical connections have been made in accordance with local codes
- Main CTs are installed to measure the current of the system to be corrected
- The secondary wiring of the main CTs have been connected to the CT board of the active filter
- If it is a parallel active filter system, CT wiring and parallel communications wiring have been installed between the CT boards of each unit
- All drives, harmonic generating loads, downstream of the main CTs must have the recommended minimum 3% line reactor or DC choke installed (required for optimum performance when harmonic mode is intended)
- There are no un-isolated capacitors, such as power factor correction capacitors downstream of the main CTs. (required when harmonic mode is intended to operate)
- At least 50% of the anticipated load should be available during the commissioning procedure. To fully test the system integration, all loads supported by the active filter system should be available for operation. The total output current required for the system must be at least 10% of the unit's nameplate rating. For example, a 300 A unit will need a minimum of 30 A total output current
- If backup generation is connected to the active filter, the system should also be tested with the generator supporting the connected loads

The Field Service Engineer will need to know the following information to commission the active filter:

- Installation location of the main CTs in relationship to the active filter (load or grid)
- The ratio of the main CTs installed
- The phase on which each CT is installed
- Intended mode of operation (Harmonic, Power Factor, Load Balancing)

### Commissioning procedures

Refer to the User Manual for commissioning procedures. The User Manual is available as a download from our website.

## **IT, HRG, and corner grounded systems**

This section provides information on using the active filter with Isolated Terra (IT), High Resistance Ground (HRG), and corner grounded systems.

---

### **WARNING**

---

#### **Hazard of electric shock, explosion, or arc flash.**

- Apply appropriate personal protective equipment (PPE) and follow safe electrical work practices. See NFPA 70E in the USA, CSA Z462, or applicable local standards
- This equipment must be installed and serviced only by qualified electrical personnel
- Do not exceed the device's ratings for maximum limits
- Ground equipment using the ground connecting point provided before turning on any power supplying this device
- Turn off all power supplying this device and the equipment in which it is installed before working on the device or equipment
- After removing power, wait for 15 minutes to allow the capacitors to discharge prior to opening the doors or removing covers
- Always use a properly rated voltage sensing device to confirm power is off
- Replace all devices, doors, and covers before turning on power to this equipment
- Carefully inspect the interior for tools left behind before closing and sealing the door

**Failure to follow these instructions will result in death or serious injury.**

---

### **NOTICE**

---

#### **Hazard of equipment damage.**

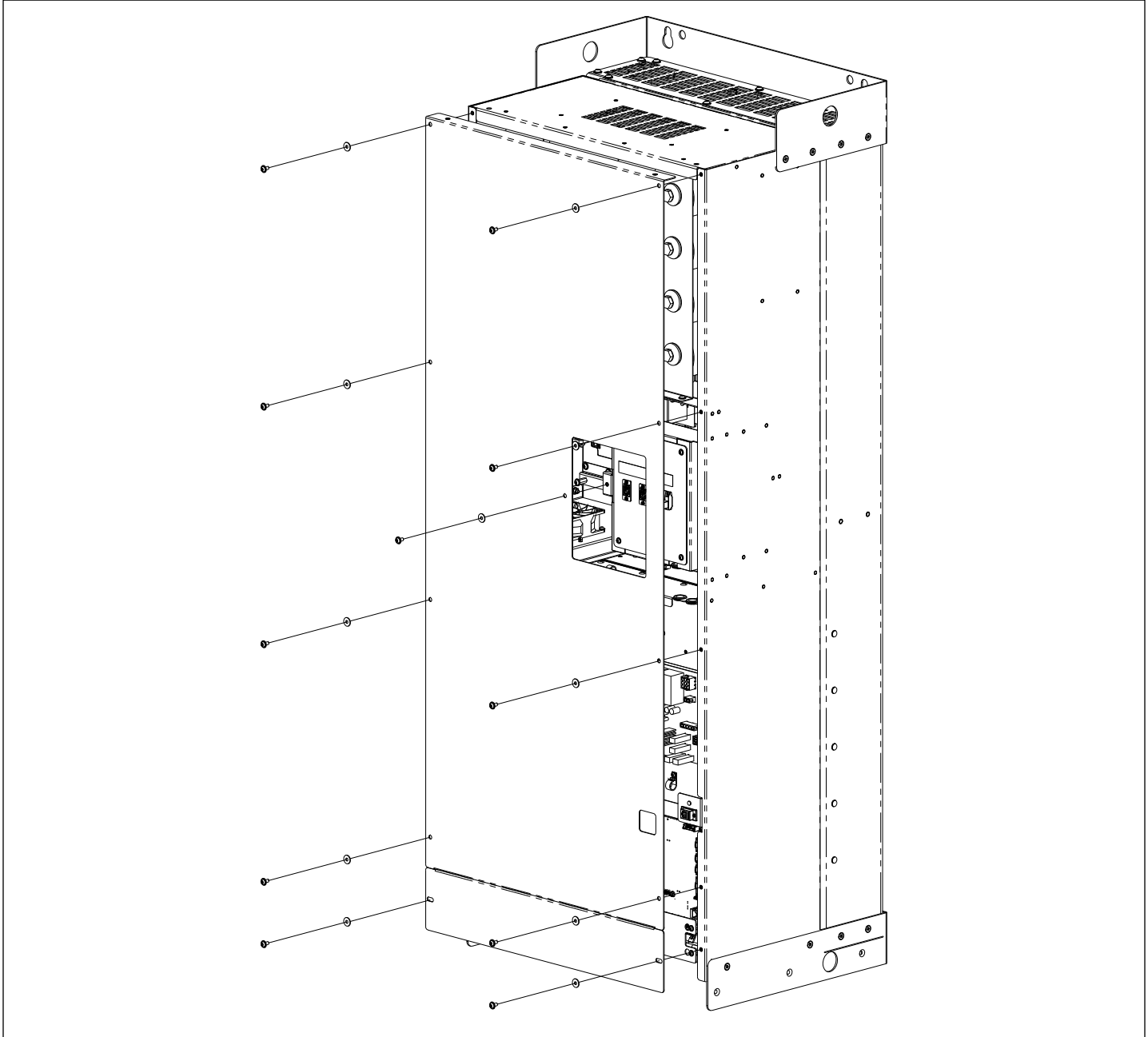
Open the IT/BP switches before operating the unit on an IT, HRG, or corner grounded system.

**Failure to follow these instructions can result in equipment damage.**

When connecting the active filter to an IT, HRG, or corner grounded system, open the IT/BP switches as follows:

1. Remove the large main cover of the unit.

**Figure 23. Main cover removal**

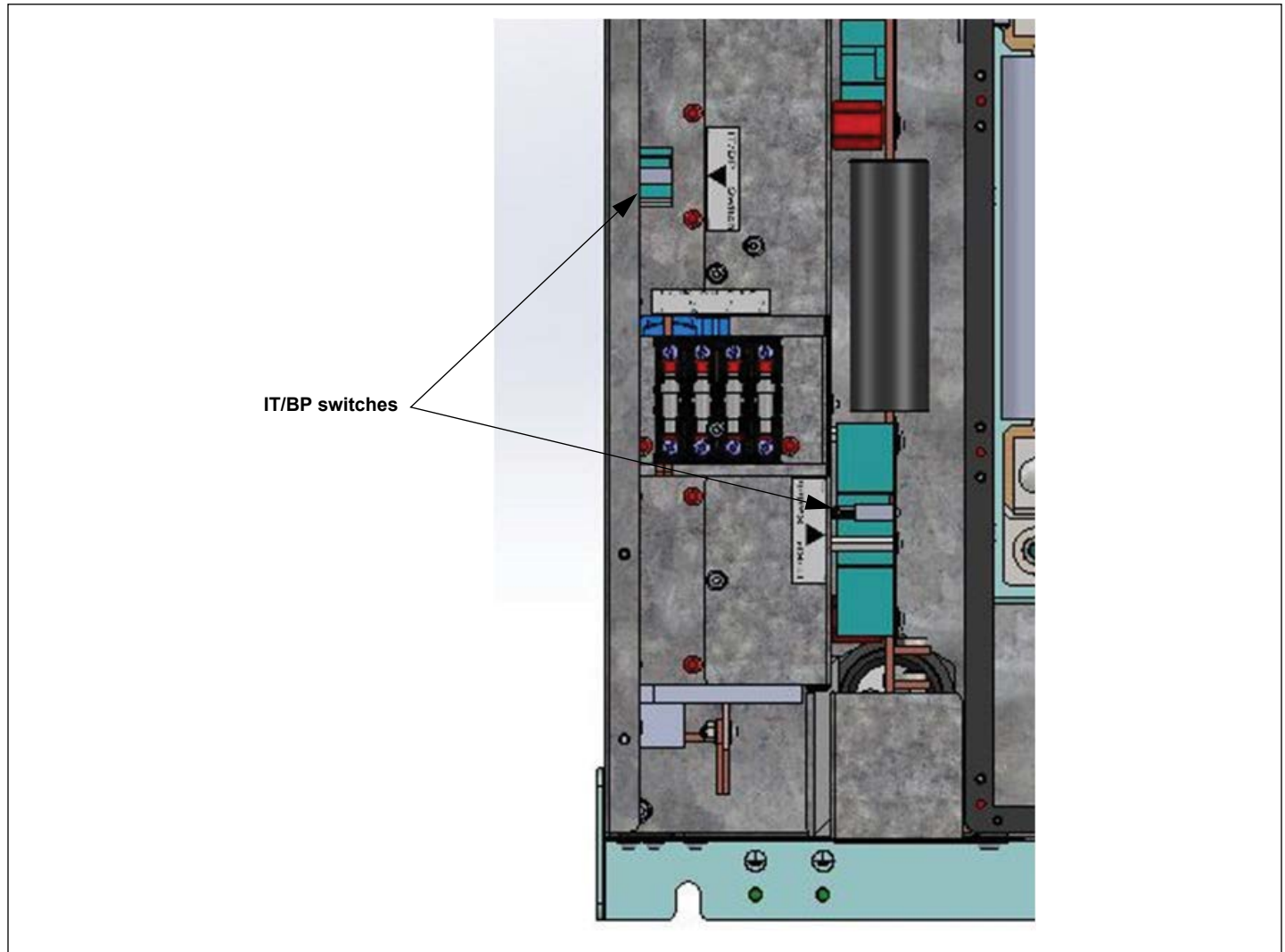


2. Locate the IT/BP switches.

Figure 24. IT/BP switch locations on 60 A and 120 A units



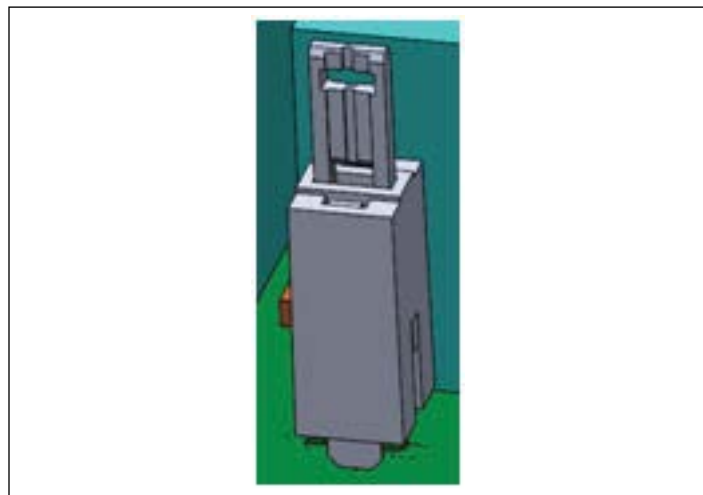
Figure 25. IT/BP switch locations on 200 A and 300 A units



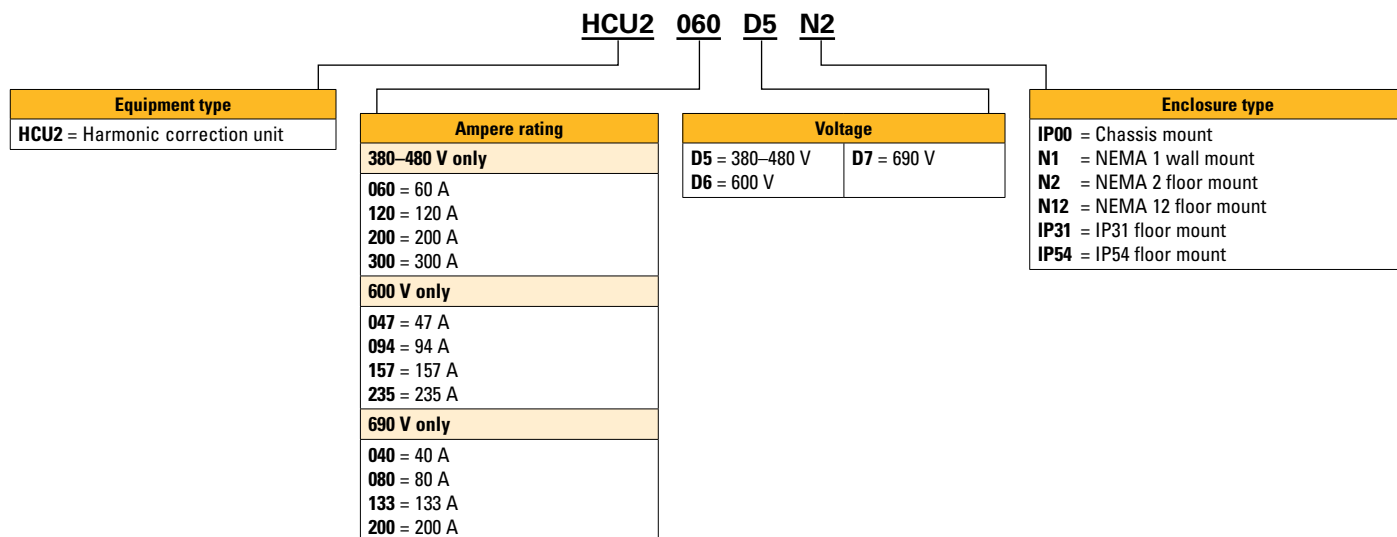
3. Pull the plunger out.

The switch is open when the plunger is completely out as shown in the figure below.

Figure 26. Plunger out/switch is open



## Catalog numbering system



## Warranty

Standard warranty is 1 year, parts only, against manufacturing defects.

## Disclaimer of warranties and limitations of liability

This instruction manual is published solely for information purposes and should not be considered all-inclusive. If further information is required, you should consult an authorized Eaton sales representative. The sale of the product shown in this literature is subject to the terms and conditions outlined in appropriate Eaton selling policies or other contractual agreement between the parties. This literature is not intended to and does not enlarge or add to any such contract. The sole source governing the rights and remedies of any purchaser of this equipment is the contract between the purchaser and Eaton.

**NO WARRANTIES, EXPRESSED OR IMPLIED, INCLUDING WARRANTIES OF FITNESS FOR A PARTICULAR PURPOSE OR MERCHANTABILITY, OR WARRANTIES ARISING FROM COURSE OF DEALING OR USAGE OF TRADE, ARE MADE REGARDING THE INFORMATION, RECOMMENDATIONS, AND DESCRIPTIONS CONTAINED HEREIN.**

In no event will Eaton be responsible to the purchaser or user in contract, in tort (including negligence), strict liability or otherwise for any special, indirect, incidental or consequential damage or loss whatsoever, including but not limited to damage or loss of use of equipment, plant or power system, cost of capital, loss of power, additional expenses in the use of existing power facilities, or claims against the purchaser or user by its customers resulting from the use of the information, recommendations and description contained herein.

For product support, please contact Eaton's  
Technical Resource Center (TRC) power quality  
application engineers at **1-800-809-2772**,  
choose option #4, then option #2.  
**[pfc@eaton.com](mailto:pfc@eaton.com)**

**Eaton**  
1000 Eaton Boulevard  
Cleveland, OH 44122  
United States  
[Eaton.com](http://Eaton.com)

© 2015 Eaton  
All Rights Reserved  
Printed in USA  
Publication No. IB156002EN / Z17448  
November 2015