



Eaton® Power Xpert™ 9395 High Performance* Field Installed UPM Mechanical Installation Manual

*Referenced throughout as 9395P



Powering Business Worldwide



Eaton® Power Xpert™ 9395 High Performance* Field Installed UPM Mechanical Installation Manual

*Referenced throughout as 9395P



Powering Business Worldwide

IMPORTANT SAFETY INSTRUCTIONS SAVE THESE INSTRUCTIONS

This manual contains important instructions that you should follow during installation and maintenance of the UPS and batteries. Please read all instructions before operating the equipment and save this manual for future reference.

CONSIGNES DE SÉCURITÉ IMPORTANTES CONSERVER CES INSTRUCTIONS

Ce manuel comporte des instructions importantes que vous êtes invité à suivre lors de toute procédure d'installation et de maintenance des batteries et de l'onduleur. Veuillez consulter entièrement ces instructions avant de faire fonctionner l'équipement et conserver ce manuel afin de pouvoir vous y reporter ultérieurement.

WARNING



This is a product for restricted sales distribution to informed partners (EN/IEC 62040-2). Installation restrictions or additional measures may be needed to prevent electromagnetic disturbances.

AVERTISSEMENT



Les ventes et la distribution de ce produit sont limitées aux partenaires avisés (EN/CEI 62040-2). Des restrictions en matière d'installation ou des mesures supplémentaires sont parfois nécessaires pour éviter les perturbations électromagnétiques.

Table of Contents

1	Introduction	1-1
1.1	Using This Manual	1-1
1.2	Conventions Used in This Manual	1-1
1.3	Symbols, Controls, and Indicators	1-3
1.4	For More Information	1-3
1.5	Getting Help	1-4
2	Safety Warnings	2-1
3	Field Installed UPM Installation Plan and Unpacking	3-1
3.1	Creating an Installation Plan	3-1
3.2	Preparing the Site	3-1
3.3	Inspecting and Unpacking the FI-UPM Cabinet	3-6
4	Field Installed UPM Installation	4-1
4.1	Preliminary Installation Information	4-1
4.2	Unloading the FI-UPM Cabinet from the Pallet	4-1
4.3	Mechanical Installation	4-3
4.4	Electrical Installation	4-5
4.5	Initial Startup	4-5
4.6	Completing the Installation Checklist	4-5
5	Warranty	W-1

List of Figures

Figure 1-1. Power Xpert 9395P Field Installed UPM	1-2
Figure 3-1. FI-UPM Cabinet Dimensions (Front View)	3-3
Figure 3-2. FI-UPM Cabinet Dimensions (Right Side View)	3-4
Figure 3-3. FI-UPM Cabinet Dimensions (Top View)	3-4
Figure 3-4. FI-UPM Cabinet Dimensions (Bottom View)	3-5
Figure 3-5. FI-UPM Cabinet Dimensions (Bottom View with Mounting Brackets)	3-5
Figure 3-6. FI-UPM Cabinet Center of Gravity	3-6
Figure 3-7. Power Xpert 9395P FI-UPM Cabinet as Shipped on Pallet	3-8
Figure 4-1. Removing the Left Side Shipping Bracket	4-2
Figure 4-2. Removing the Right Side Shipping Bracket	4-3
Figure 4-3. UPS Cabinet Wire Entry Plate and Knockout Locations	4-4

Chapter 1

Introduction

The Power Xpert® 9395P Field Installed UPM (FI-UPM) provides increased capacity or N+1 redundancy for Power Xpert 9395P UPS systems. Capacity increase depends on the capabilities of the originally installed system. The FI-UPM may be installed at any time when power needs change. The module cabinet installs on the left side of the UPS cabinet and wires directly to the UPS. No input or output wiring changes are needed for a capacity increase if the original installation was wired with increased capacity in mind. Operation remains the same as the original UPS.

The FI-UPM is housed in a single, free-standing cabinet with safety shields behind the front panel for hazardous voltage protection. The cabinet matches the UPS cabinet in style and color. Figure 1-1 shows the Power Xpert 9395P FI-UPM.



NOTE *Wiring, startup, and operational checks must be performed by an authorized Eaton Customer Service Engineer, or the warranty terms specified on page W-1 become void. This service is offered as part of the sales contract for the FI-UPM. Contact an Eaton service representative in advance (usually a two-week notice is required) to request service.*

1.1 Using This Manual

This manual describes how to mechanically install the Power Xpert 9395P FI-UPM cabinet. Electrical installation will be performed by an Eaton Customer Service Engineer. Read and understand the procedures described in this manual to ensure trouble-free installation.

1.2 Conventions Used in This Manual

This manual uses these type conventions:

- **Bold type** highlights important concepts in discussions, key terms in procedures, and menu options, or represents a command or option that you type or enter at a prompt.
- *Italic type* highlights notes and new terms where they are defined.
- **Screen type** represents information that appears on the screen or LCD.

Icon	Description
	Information notes call attention to important features or instructions.
[Keys]	Brackets are used when referring to a specific key, such as [Enter] or [Ctrl].

In this manual, the term *UPS* refers only to the UPS cabinet and its internal elements. The term *UPS system* refers to the entire power protection system – the UPS cabinet, the battery cabinet, and options or accessories installed.

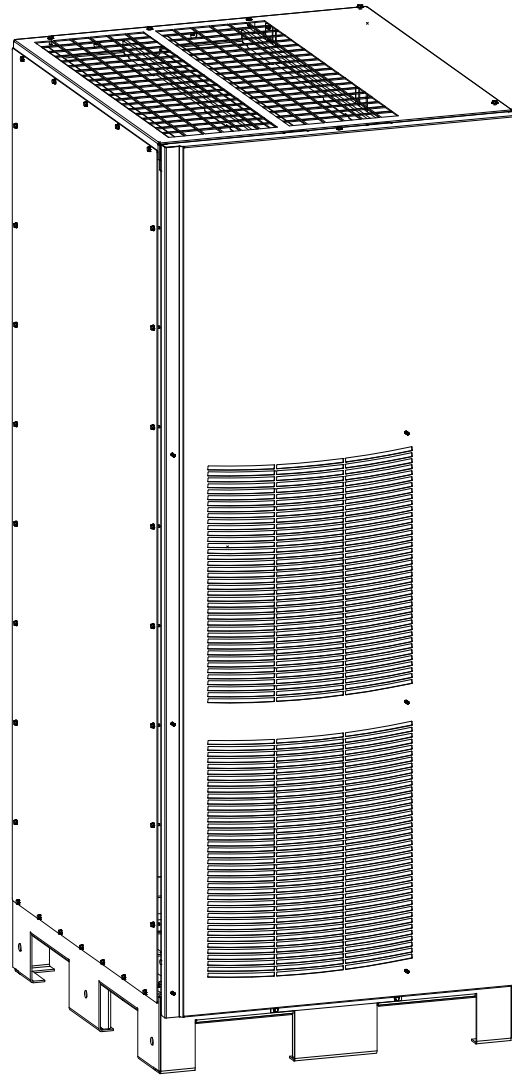

Figure 1-1. Power Xpert 9395P Field Installed UPM

1.3 Symbols, Controls, and Indicators

The following are examples of symbols used on the UPS or accessories to alert you to important information:



RISK OF ELECTRIC SHOCK - Observe the warning associated with the risk of electric shock symbol.



CAUTION: REFER TO OPERATOR'S MANUAL - Refer to your operator's manual for additional information, such as important operating and maintenance instructions.



This symbol indicates that you should not discard the UPS or the UPS batteries in the trash. This product contains sealed, lead-acid batteries and must be disposed of properly. For more information, contact your local recycling/reuse or hazardous waste center.



This symbol indicates that you should not discard waste electrical or electronic equipment (WEEE) in the trash. For proper disposal, contact your local recycling/reuse or hazardous waste center.

1.4 For More Information

Refer to the following manuals for additional information:

- *Eaton Power Xpert 9395P UPS (650-900 kVA) Installation and Operation Manual*
- *Eaton Power Xpert 9395P UPS (1000-1200 kVA) Installation and Operation Manual*

These manuals describe:

- UPS cabinet, optional components, and accessory installation instructions, including site preparation, planning for installation, and wiring and safety information. Detailed illustrations of cabinets and optional accessories with dimensional and connection point drawings are provided.
- UPS operation, including UPS cabinet controls, functions of the UPS, standard features and optional accessories, procedures for starting and stopping the UPS, and information about maintenance and responding to system events.
- Communication capabilities of the UPS system.

Visit www.eaton.com/powerquality or contact Eaton service representative for information on how to obtain copies of these manuals.

1.5 Getting Help

If help is needed with any of the following:

- Scheduling initial startup
- Regional locations and telephone numbers
- A question about any of the information in this manual
- A question this manual does not answer

Please call the Eaton Help Desk at:

United States: **1-800-843-9433 or 1-919-870-3028**
Canada: **1-800-461-9166 ext 260**
All other countries: **Call your local service representative**

IMPORTANT SAFETY INSTRUCTIONS SAVE THESE INSTRUCTIONS

This manual contains important instructions that should be followed during installation of the Field Installed UPM (FI-UPM). Read all instructions before operating the equipment and save this manual for future reference.

The FI-UPM cabinet is designed for industrial or computer room applications, and contains safety shields behind the panel. However, the FI-UPM is a sophisticated power system and should be handled with appropriate care.

DANGER



The FI-UPM contains **LETHAL VOLTAGES**. All repairs and service should be performed by **AUTHORIZED SERVICE PERSONNEL ONLY**. There are **NO USER SERVICEABLE PARTS** inside the FI-UPM.

DANGER!



Cet FI-UPM peut générer des **TENSIONS MORTELLES**. L'installation et l'entretien ne doivent être effectués que par le **PERSONNEL AUTORISÉ**. Ne contient **AUCUNE PIÈCE REMPLAÇABLE**.

WARNING



- The UPS system contains its own energy source (batteries). The output terminals may carry live voltage even when the UPS is disconnected from an AC source.
- To reduce the risk of fire or electric shock, install this UPS and FI-UPM in a temperature and humidity controlled, indoor environment, free of conductive contaminants. Ambient temperature must not exceed 40°C (104°F). Do not operate near water or excessive humidity (95% maximum). The system is not intended for outdoor use.
- Ensure all power is disconnected before performing installation or service.
- **ELECTRIC ENERGY HAZARD**. Do not attempt to alter any battery wiring or connectors. Attempting to alter wiring can cause injury.

AVERTISSEMENT!



- L'onduleur est alimenté par sa propre source d'énergie (batteries). Les bornes de sortie peuvent être sous tension, même lorsque l'onduleur est débranché d'une source de courant alternatif.
- Pour réduire les risques d'incendie et de décharge électrique, installer l'onduleur à l'intérieur, dans un endroit exempt d'éléments conducteurs et où la température et l'humidité sont régulées. La température ambiante ne doit pas dépasser 40°C (104°F). Ne pas faire fonctionner près d'une source d'eau ou dans un endroit très humide (95 % maximum). Le système n'est pas conçu pour une utilisation extérieure.
- Toutes les sources d'alimentation doivent être débranchées avant de procéder à l'installation et à l'entretien.
- **DANGERS ÉLECTRIQUES**. Ne pas tenter de modifier le câblage et les connecteurs de l'onduleur ou des batteries. Toute tentative de modification peut provoquer des blessures.

CAUTION



- Keep the FI-UPM front panel installed to ensure proper cooling airflow and to protect personnel from dangerous voltages inside the unit.
- Do not install or operate the UPS system or FI-UPM close to gas or electric heat sources.

- The operating environment should be maintained within the parameters stated in this manual.
 - Keep surroundings uncluttered, clean, and free from excess moisture.
 - Observe all DANGER, CAUTION, and WARNING notices affixed to the inside and outside of the equipment.
-



ATTENTION!

- Garder les portes de l'onduleur fermées et les panneaux avant en place pour garantir une circulation adéquate de l'air de refroidissement et pour protéger le personnel des tensions dangereuses dans l'unité.
 - Ne pas installer ni faire fonctionner l'onduleur près d'une source de chaleur au gaz ou à l'électricité.
 - Le milieu de fonctionnement doit toujours correspondre aux paramètres établis dans ce manuel.
 - Maintenir les lieux rangés, propres et exempts d'une humidité excessive.
 - Respecter les étiquettes DANGER, MISE EN GARDE et AVERTISSEMENT se trouvant à l'intérieur et à l'extérieur de l'équipement.
-

Chapter 3

Field Installed UPM Installation Plan and Unpacking

Use the following basic sequence of steps to install the Field Installed UPM (FI-UPM):

1. Create an installation plan for the FI-UPM (Chapter 3).
2. Prepare your site for the FI-UPM (Chapter 3).
3. Inspect and unpack the FI-UPM cabinet (Chapter 3).
4. Unload and install the FI-UPM cabinet (Chapter 4).
5. Complete the Installation Checklist (Chapter 4).
6. Have authorized service personnel install wiring, perform preliminary operational checks, and start up the system.



NOTE *Wiring, startup, and operational checks must be performed by an authorized Eaton Customer Service Engineer, or the warranty terms specified on page W-1 become void. This service is offered as part of the sales contract for the FI-UPM. Contact an Eaton service representative in advance (usually a two-week notice is required) to request service.*

3.1 Creating an Installation Plan

Before installing the FI-UPM, read and understand how this manual applies to the system being installed. Use the procedures and illustrations in paragraph 3.2 and Chapter 4 to create a logical plan for installing the system.

3.2 Preparing the Site

For the FI-UPM to operate at peak efficiency, the installation site should meet the environmental parameters outlined in this manual. If the FI-UPM is to be operated at an altitude higher than 1000m (3330 ft), contact an Eaton service representative for important information about high altitude operation. The operating environment must meet the weight, clearance, and environmental requirements specified.

The FI-UPM installation must meet the following guidelines:

- The system must be installed on a level floor suitable for computer or electronic equipment.
- The system must be installed in a temperature and humidity controlled indoor area free of conductive contaminants.
- The cabinet must be installed in *line-up-and-match* configuration.

Failure to follow guidelines may void your warranty.

The FI-UPM operating environment must meet the maximum weight requirements shown in Table 3-1 and the size requirements shown in Figure 3-1 through Figure 3-6. Dimensions are in millimeters (inches).

Table 3-1 includes the weights of the heaviest cabinet configuration. Actual weights may be less due to the installed configuration. Weights are in kilograms (pounds).

Table 3-1. FI-UPM Cabinet Maximum Weight

Model	Maximum Weight kg (lb)	
	Shipping	Installed
Power Xpert 9395P FI-UPM	496 (1094)	471 (1037)

The FI-UPM cabinet uses forced air cooling to regulate internal component temperature. Air inlets are in the front of the cabinet and outlets are in the top. Allow clearance in front of and above each cabinet for proper air circulation. The clearances required around the FI-UPM cabinet are shown in Table 3-2. Dimensions are in millimeters (inches).

Table 3-2. FI-UPM Cabinet Clearances

From Top of Cabinet	457.2 mm (18") minimum clearance for ventilation
From Front of Cabinet	914.4 mm (36") working space
From Back of Cabinet	None Required
From Right Side of Cabinet	None Required
From Left Side of Cabinet	None Required

The basic environmental requirements for operation of the FI-UPM are:

- Ambient Temperature Range: 0–40°C (32–104°F)
- Recommended Operating Range: 20–25°C (68–77°F)
- Maximum Relative Humidity: 95%, non-condensing

The FI-UPM ventilation requirements are shown in Table 3-3.

Table 3-3. FI-UPM Air Conditioning or Ventilation Requirements During Full Load Operation

Rating	Input/Output Voltage	Heat Rejection kW (1000 BTU/hr)	Ventilation Required for Cooling Air Exhaust
225 kVA	480/480	7.9 (27.1)	Approximately 950 liter/sec (2000 CFM)
250 kVA	480/480	9.3 (31.9)	
275 kVA	480/480	10.6 (36.1)	
300 kVA	480/480	10.6 (36.1)	

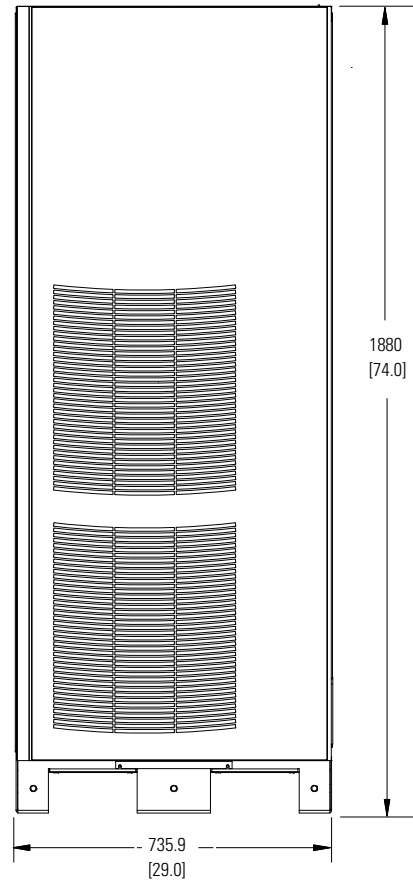

Dimensions are in millimeters [inches].

Figure 3-1. FI-UPM Cabinet Dimensions (Front View)

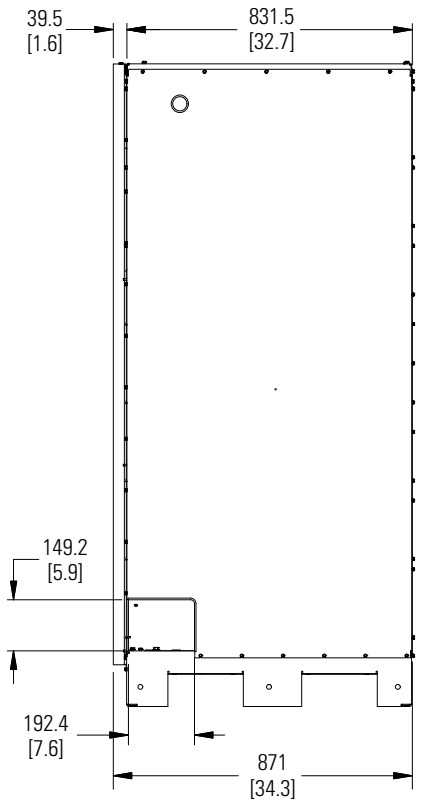

Dimensions are in millimeters [inches].

Figure 3-2. FI-UPM Cabinet Dimensions (Right Side View)

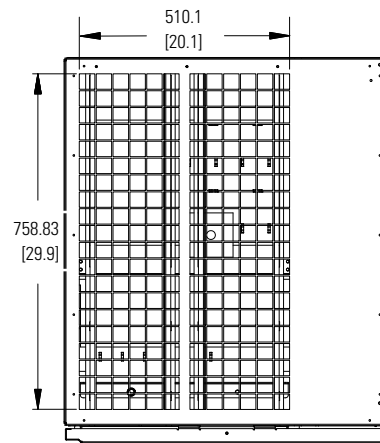

Front

Dimensions are in millimeters [inches].

Figure 3-3. FI-UPM Cabinet Dimensions (Top View)

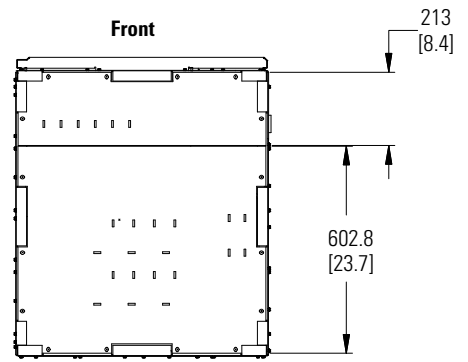

Dimensions are in millimeters [inches].

Figure 3-4. FI-UPM Cabinet Dimensions (Bottom View)

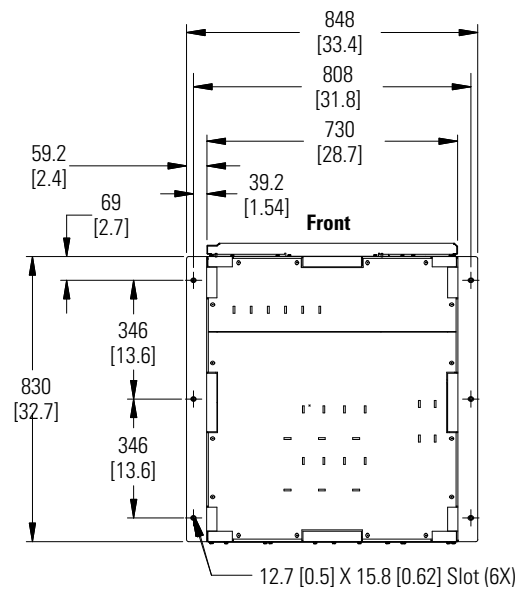

Dimensions are in millimeters [inches].

Figure 3-5. FI-UPM Cabinet Dimensions (Bottom View with Mounting Brackets)

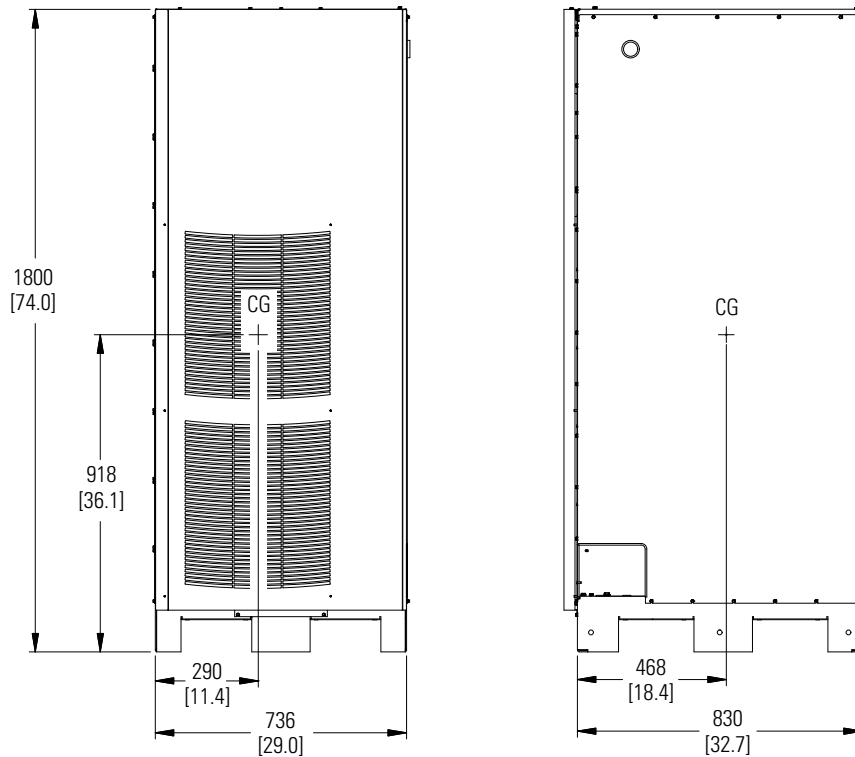

Dimensions are in millimeters [inches].

Figure 3-6. FI-UPM Cabinet Center of Gravity

3.3 Inspecting and Unpacking the FI-UPM Cabinet

The FI-UPM cabinet is palletted separately for shipping. The cabinet is shipped bolted to a wooden pallet and protected with outer protective packaging material (see Figure 3-7).

WARNING



The FI-UPM cabinet is heavy (see Table 3-1 on page 3-2). If unpacking and unloading instructions are not closely followed, the cabinet may tip and cause serious injury.

AVERTISSEMENT!



Les sections de l'onduleur sont lourdes (voir le Table 3-1). Suivre attentivement les instructions de déchargement et de déballage pour éviter de renverser les armoires, ce qui pourrait causer de graves blessures.

1. Carefully inspect the outer packaging for evidence of damage during transit.

CAUTION



Do not install a damaged cabinet. Report any damage to the carrier and contact an Eaton service representative immediately.

ATTENTION!



Ne pas installer une armoire endommagée. Signaler les dommages au transporteur et communiquer avec un représentant du service Eaton immédiatement.



NOTE For the following step, verify that the forklift or pallet jack is rated to handle the weight of the cabinet (see Table 3-1 on page 3-2 for cabinet weight).

2. Use a forklift or pallet jack to move the packaged cabinet to the installation site, or as close as possible, before unpacking. If possible, move the cabinet using the pallet. Insert the forklift or pallet jack forks from the right side of the pallet (facing the cabinet), between the supports on the bottom of the pallet (see Figure 3-6 for the FI-UPM cabinet center of gravity measurements).



CAUTION

Do not tilt the FI-UPM cabinet more than 10° from vertical or the cabinet may tip over.



ATTENTION!

Ne pas incliner les armoires FI-UPM à plus de 10 degrés de la verticale puisqu'elles pourraient se renverser.

3. Set the pallet on a firm, level surface, allowing a minimum clearance of 3m (10 ft) on each side for removing the cabinet from the pallet.



NOTE The FI-UPM cabinet is shipped with a debris shield covering the ventilation grill on top of the unit. Do not remove the debris shield until installation is complete.

4. Remove the protective covering from the cabinet.
5. Remove the packing material, and discard or recycle in a responsible manner.
6. Inspect the contents for any evidence of physical damage, and compare each item with the Bill of Lading. If damage has occurred or shortages are evident, contact an Eaton service representative immediately to determine the extent of the damage and its impact on further installation.



NOTE While waiting for installation, protect the unpacked cabinet from moisture, dust, and other harmful contaminants. Failure to store and protect the FI-UPM properly may void your warranty.

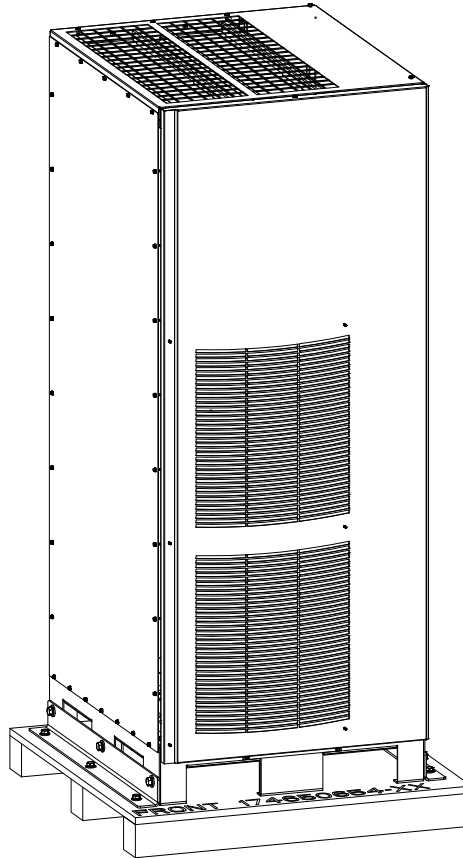

Figure 3-7. Power Xpert 9395P FI-UPM Cabinet as Shipped on Pallet

Chapter 4

Field Installed UPM Installation

4.1 Preliminary Installation Information



WARNING

Installation should be performed only by qualified personnel.



AVERTISSEMENT!

L'installation ne doit être effectuée que par du personnel qualifié.

Refer to the following while installing the Field Installed UPM (FI-UPM):

- Chapter 3 for cabinet dimensions, equipment weight, wiring and terminal data, and installation notes.
- Do not tilt the cabinet more than $\pm 10^\circ$ during installation.
- The FI-UPM cabinet is installed on the left side of the UPS cabinet.
- The FI-UPM cabinet is shipped with a debris shield covering the ventilation grill on top of the unit. Do not remove the debris shield until installation is complete. However, remove the shield before operating the UPS system. Once the debris shield is removed, do not place objects on the ventilation grill.
- A FI-UPM is always designated as UPM 4.

4.2 Unloading the FI-UPM Cabinet from the Pallet

The FI-UPM cabinet is bolted to a wooden pallet supported by wood skids. To remove the pallet:



WARNING

The FI-UPM cabinet is heavy (see Table 3-1 on page 3-2). If unpacking and unloading instructions are not closely followed, the cabinet may tip and cause serious injury.



AVERTISSEMENT!

Les sections de l'onduleur sont lourdes (voir le tableau 3-1). Suivre attentivement les instructions de déchargement et de déballage pour éviter de renverser les armoires, ce qui pourrait causer de graves blessures.



CAUTION

- Do not tilt cabinets more than 10° from vertical.
- Lift the cabinet only with a forklift or damage may occur.



ATTENTION!

- Ne pas incliner les armoires à plus de 10 degrés de la verticale.
- Ne soulever les armoires qu'à l'aide d'un chariot élévateur pour éviter de les endommager.



NOTE For the following steps, verify that the forklift or pallet jack is rated to handle the weight of the cabinet (see Table 3-1 on page 3-2 for cabinet weight).

1. If not already accomplished, use a forklift or pallet jack to move the cabinet to the installation area, or as close as possible, before unloading from the pallet. If possible, move the cabinet using the pallet. Insert the forklift or pallet jack forks from the right side of the pallet (facing the cabinet), between the supports on the bottom of the pallet (see Figure 3-6 on page 3-6 for the FI-UPM cabinet center of gravity measurements).
2. Remove the three bolts securing the left side shipping bracket to the cabinet and three bolts securing the bracket to the pallet (see Figure 4-1). Remove the left side shipping bracket. If installing the cabinet permanently, retain the shipping bracket and securing hardware for later use.

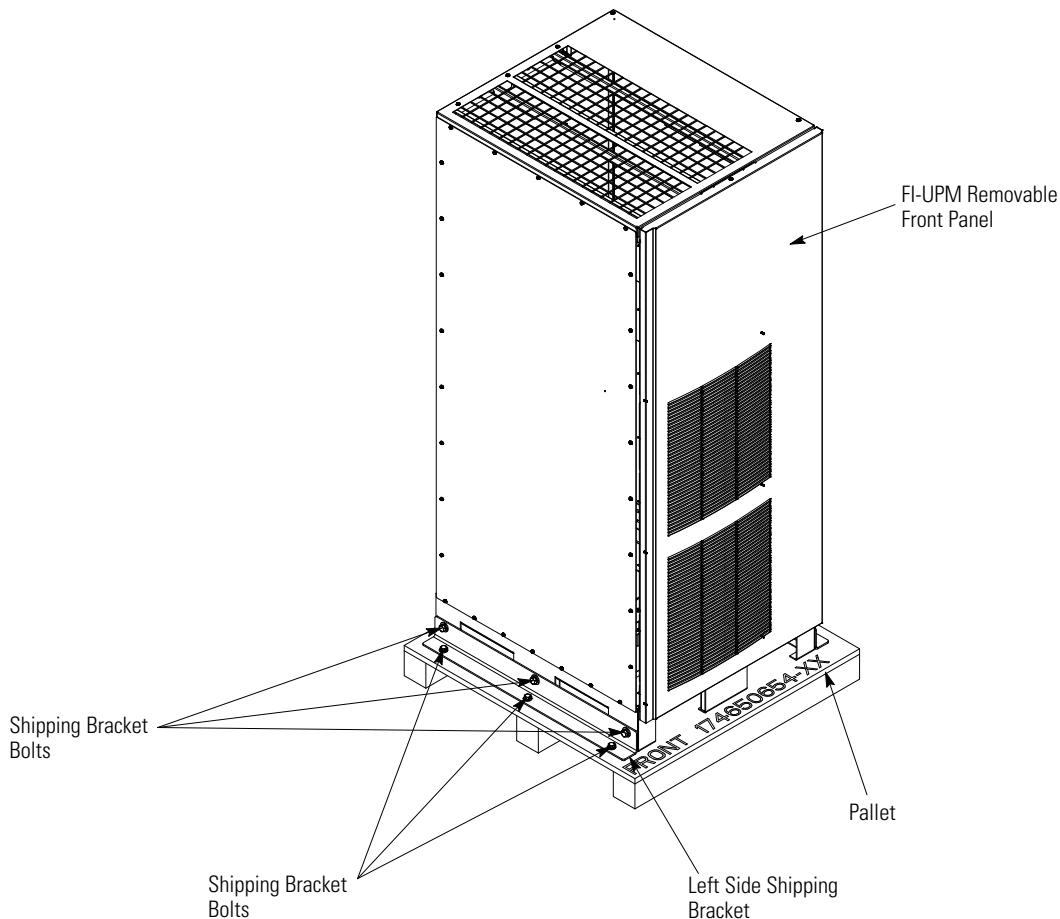

Figure 4-1. Removing the Left Side Shipping Bracket

3. Remove the three bolts securing the right side shipping bracket to the cabinet and three bolts securing the bracket to the pallet (see Figure 4-2). Remove the right side shipping bracket.
4. Using a forklift, raise the FI-UPM cabinet section until the cabinet bottom clears the pallet by approximately 3 mm (1/8”).
5. Pull the pallet from under the FI-UPM cabinet.

6. Discard or recycle the pallet and unused shipping brackets in a responsible manner.
7. Carefully lower the FI-UPM cabinet until the cabinet base contacts the floor.

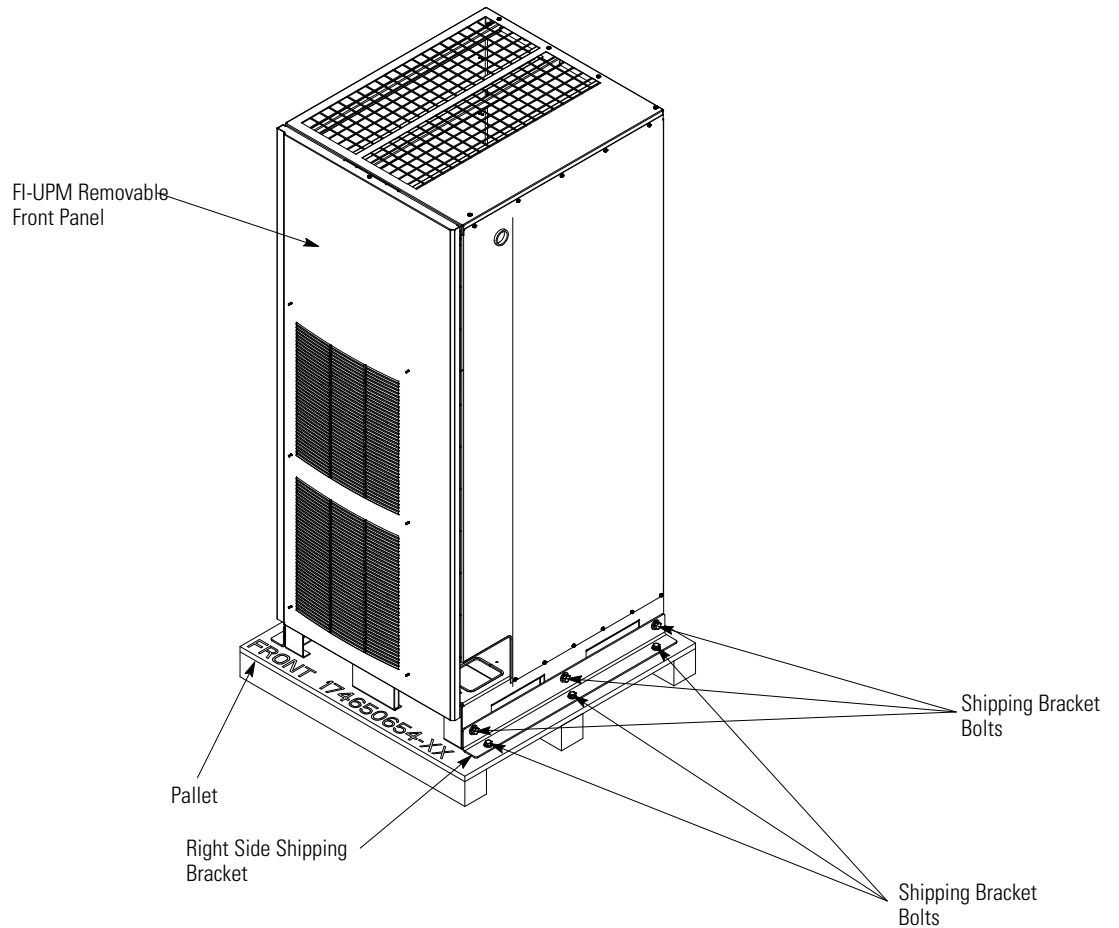

Figure 4-2. Removing the Right Side Shipping Bracket

4.3 Mechanical Installation

To mechanically install the FI-UPM:

1. Remove the wire entry plate located on the bottom left side of the UPS cabinet (see Figure 4-3).
2. If not already removed, remove the wire entry knockout located on the top left side of the UPS cabinet (see Figure 4-3).
3. Locate the hardware kit (packed inside of the cabinet). Locate the nylon grommet from the hardware kit. If not already installed, install the nylon grommet in the knockout hole.
4. Using a forklift, move the FI-UPM cabinet to the final installed location on the left side of the UPS cabinet. Verify that the FI-UPM cabinet right side is against the UPS cabinet left side and the front panels are flush with each other.
5. Carefully lower the FI-UPM cabinet until the cabinet base contacts the floor.



NOTE A flat cabinet joining bracket is provided for securing the cabinets at the top front (see Step 7).

6. Remove and retain one top screw and two bottom screws securing the FI-UPM front panel (see Figure 4-2). Lift the panel straight up to remove it from the panel hanger bracket at the top of the cabinet.
7. Locate the small flat bracket and screws from the hardware kit. Align the holes in the small flat bracket over holes in the top of the FI-UPM and UPS cabinets. Secure the bracket with the screws from the hardware kit.
8. Reinstall the FI-UPM front panel removed in Step 6, and secure with the retained hardware.
9. If permanently mounting the system, proceed to Step 10; otherwise, continue to Step 12.
10. Using the retained hardware, reinstall the left shipping bracket removed in paragraph 4.2, Step 2 on page 4-2 to the left side of the FI-UPM cabinet with the angle facing outward (see Figure 4-1 on page 4-2).
11. Secure the cabinet to the floor with customer-supplied hardware.
12. Proceed to paragraph 4.4.

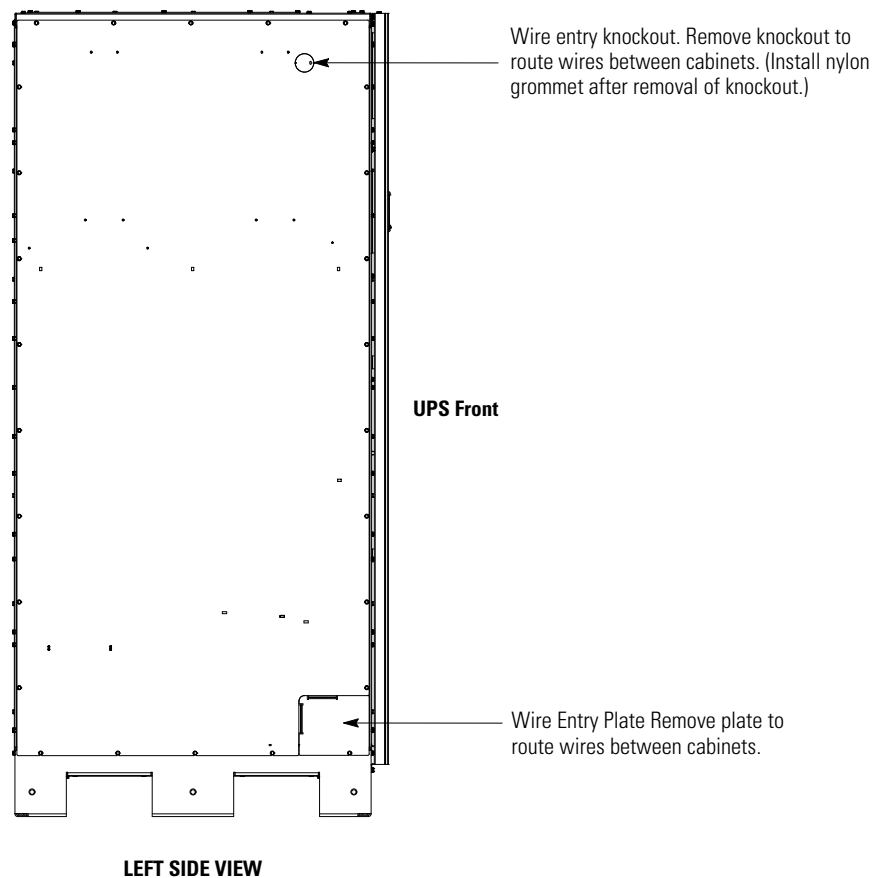

Figure 4-3. UPS Cabinet Wire Entry Plate and Knockout Locations

4.4 Electrical Installation

Install FI-UPM battery wiring from the battery cabinet to the FI-UPM battery terminal location in the UPS (refer to the applicable UPS manual listed in paragraph 1.4 on page 1-3). Wiring between the FI-UPM and the UPS, and FI-UPM battery terminals will be installed by an Eaton Customer Service Engineer. This service is offered as part of the sales contract for the FI-UPM. Contact an Eaton service representative in advance (usually a two-week notice is required) to request service.

4.5 Initial Startup

Startup and operational checks must be performed by an authorized Eaton Customer Service Engineer, or the warranty terms specified on page W-1 become void. This service is offered as part of the sales contract for the FI-UPM. Contact an Eaton service representative in advance (usually a two-week notice is required) to reserve a preferred startup date.

4.6 Completing the Installation Checklist

The final step in installing the FI-UPM is completing the following Installation Checklist. This checklist ensures that all hardware, cables, and other equipment have been completely installed. Complete all items listed on the checklist to ensure a smooth installation. Make a copy of the Installation Checklist before filling it out, and retain the original.

After the installation is complete, an Eaton Customer Service Engineer must verify the operation of the FI-UPM and UPS system and commission it to support the critical load. The service representative will verify software and operating setup parameters. Service personnel may request a copy of the completed Installation Checklist to verify all applicable equipment installations have been completed.



NOTE *The Installation Checklist MUST be completed prior to starting the FI-UPM and UPS system for the first time.*

Installation Checklist

- All packing materials and restraints have been removed from the cabinet.
- UPS cabinet wire entry plate and knockout have been removed from the cabinet.
- The FI-UPM cabinet is placed in its installed location.
- A cabinet grounding/mounting kit is installed between the FI-UPM and UPS cabinets.
- All cables are properly routed from the FI-UPM to the UPS.
- Air conditioning equipment is installed and operating correctly.
- The area around the installed UPS system is clean and dust-free. (It is recommended that the UPS be installed on a level floor suitable for computer or electronic equipment.)
- Adequate workspace exists around the FI-UPM and UPS cabinets.
- Adequate lighting is provided around all UPS equipment.
- A 120 Vac or 230 Vac service outlet (depending on local mains voltage) is located within 7.5 meters (25 feet) of the UPS equipment.
- The debris shield covering the FI-UPM cabinet ventilation grill is removed.
- Startup and operational checks are performed by an authorized Eaton Customer Service Engineer.

This page intentionally left blank.

Warranty

LIMITED FACTORY WARRANTY FOR EATON THREE-PHASE UPS PRODUCTS

WARRANTOR: The warrantor for the limited warranties set forth herein is Eaton (“Eaton”).

LIMITED WARRANTY: This limited warranty (this “Warranty”) applies only to the original End-user (the “End-user”) of the Eaton three-phase UPS Products (the “Product”) and cannot be transferred. This Warranty applies even in the event that the Product is initially sold by Eaton for resale to an End-user.

LIMITED WARRANTY PERIOD: The period covered by this Warranty for Product installed [and currently located] in the fifty (50) United States and the District of Columbia is twelve (12) months from the date of Product startup or eighteen (18) months from date of Product shipment, whichever occurs first, for parts coverage and 90 days from the date of Product startup for labor coverage. The period covered by this Warranty for Product installed [and currently located] outside of the fifty (50) United States and the District of Columbia is twelve (12) months from the date of Product startup or eighteen (18) months from date of Product shipment, whichever occurs first, for parts coverage.

WHAT THIS LIMITED WARRANTY COVERS: The warrantor warrants that the Eaton three-phase UPS electronics, Eaton-built accessories, and Eaton-built battery cabinets, (individually and collectively, the “Warranted Items”) are free from defects in material and workmanship. If, in the opinion of Eaton, a Warranted Item is defective and the defect is within the terms of this Warranty, Eaton’s sole obligation will be to repair or replace such defective item (including by providing service, parts and labor, as applicable), at the option of Eaton. The Warranted Item will be repaired or replaced onsite at the End-user’s location or such other location as determined by Eaton. Any parts that are replaced may be new or reconditioned. All parts replaced by Eaton shall become the property of Eaton.

WHAT THIS LIMITED WARRANTY DOES NOT COVER: This Warranty does not cover any defects or damages caused by: (a) failure to properly store the Product before installation, including the “trickle charge” of batteries no later than the date indicated on the packaging; (b) shipping and delivery of the Product if shipping is FOB Factory; (c) neglect, accident, fire, flood, lightning, vandalism, acts of God, Customer’s neglect, abuse, misuse, misapplication, incorrect installation; (d) repair or alteration, not authorized in writing by Eaton personnel or performed by an authorized Eaton Customer Service Engineer or Agent; or (e) improper testing, operation, maintenance, adjustment or any modification of any kind not authorized in writing by Eaton personnel or performed by an authorized Eaton Customer Service Engineer or Agent.

This Warranty is not valid: (a) unless an authorized Eaton Customer Service Engineer (in USA) or Agent (outside of USA) performs startup and commissioning of the Product; (b) if the Product is moved to a new location by someone other than an authorized Eaton Customer Service Engineer (in USA) or Agent (outside of USA); or (c) if the Product’s serial numbers have been removed or are illegible. Any Warranted Items repaired or replaced pursuant to this Warranty will be warranted for the remaining portion of the original Warranty subject to all the terms thereof. Labor warranty is not provided for Product located outside of the fifty (50) United States or the District of Columbia. Any equipment, parts or materials included in the Product and not manufactured by Eaton are warranted solely by the manufacturer of such equipment, parts or materials and are not included as part of this warranty. Batteries are not warranted by Eaton.

THIS WARRANTY IS THE END-USER’S SOLE REMEDY AND IS EXPRESSLY IN LIEU OF, AND THERE ARE NO OTHER, EXPRESSED OR IMPLIED GUARANTEES OR WARRANTIES (INCLUDING ANY IMPLIED WARRANTY OF MERCHANTABILITY OR FITNESS FOR ANY PURPOSE, WHICH ARE EXPRESSLY DISCLAIMED).

LIMITATION OF LIABILITY: In no event shall Eaton be liable for any indirect, incidental, special or consequential damages of any kind or type whatsoever, or based on any claim or cause of action, however denominated. Eaton shall not be responsible for failure to provide service or parts due to causes beyond Eaton’s reasonable control. In no case will Eaton’s liability under this Warranty exceed the replacement value of the Warranted Items.

END-USER’S OBLIGATIONS: In order to receive the benefits of this Warranty, the End-user must use the Product in a normal way; follow the Product’s operators and maintenance manual; and protect against further damage to the Product if there is a covered defect.

OTHER LIMITATIONS: Eaton’s obligations under this Warranty are expressly conditioned upon receipt by Eaton of all payments due to it (including interest charges, if any). During such time as Eaton has not received payment of any amount due to it for the Product, in accordance with the contract terms under which the Product is sold, Eaton shall have no obligation under this Warranty. Also during such time, the period of this Warranty shall continue to run and the expiration of this Warranty shall not be extended upon payment of any overdue or unpaid amounts.

COSTS NOT RELATED TO WARRANTY: The End-user shall be invoiced for, and shall pay for, all services not expressly provided for by the terms of this Warranty, including without limitation, site calls involving an inspection that determines no corrective maintenance is required. Any costs for replacement equipment, installation, materials, freight charges, travel expenses or labor of Eaton representatives outside the terms of this Warranty will be borne by the End-user.

OBTAINING WARRANTY SERVICE: In the USA, call the Customer Reliability Center 7x24 at 800.843.9433. Outside of the USA, contact your local Eaton product sales or service representative for units purchased from those countries, or call the Customer Reliability Center in the USA at 919.845.3633 for units purchased in the USA that were shipped overseas. For comments or questions about this Warranty, write to the Customer Quality Representative, 8609 Six Forks Road, Raleigh, North Carolina 27615 USA.

This page intentionally left blank.



P-16400503 1