

# LIB System for UPS

## Operation and Maintenance Manual

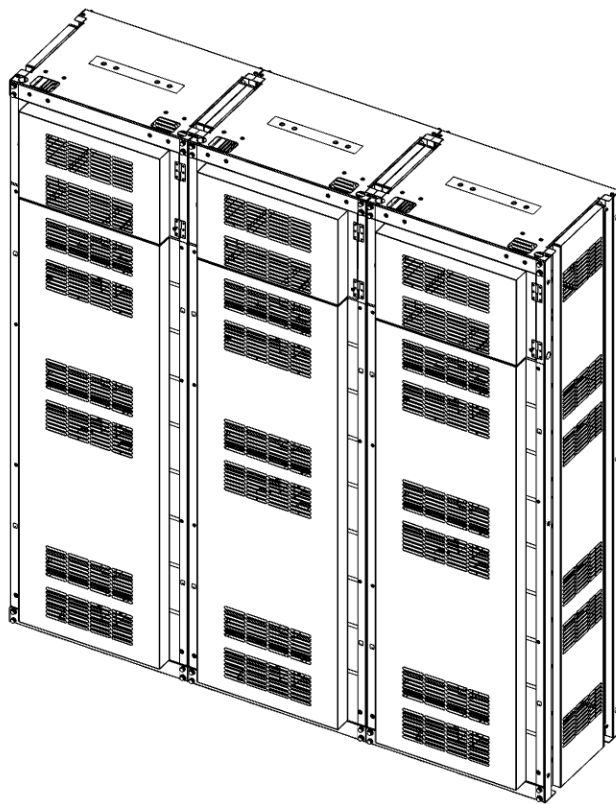

***Read this manual carefully before starting to install the battery system. Keep these instructions for future reference.***

**CONFIDENTIAL**

---

Copyright © 2019 SAMSUNG SDI Co., Ltd. All rights reserved.

This document contains information that is the property of SAMSUNG SDI Co., Ltd., and provides for the sole purpose of the installation, operation, and maintenance of products of SAMSUNG SDI Co., Ltd. No part of this publication is to be used for any other purpose. It is not to be reproduced, copied, disclosed, transmitted, stored in a retrieval system, or translated into any human or computer language in any form, by any means, in whole or in part, without the prior written consent of SAMSUNG SDI Co., Ltd.





Although every possible effort has been made to ensure the accuracy of this document, SAMSUNG SDI Co., Ltd. assumes no responsibility for errors that may appear herein. The information is subject to change without notice.



# Important Safety Instructions

## Read and follow these instructions!

The following precautions are intended to ensure your safety and prevent property damage. Before installing this product, be sure to read all safety instructions in this document.

	<p><b>DANGER</b></p> <p>Failure to comply with the instructions with this symbol may result in a serious accident, causing death or severe injury.</p>
	<p><b>WARNING</b></p> <p>Failure to comply with the instructions with this symbol may result in a serious accident, causing severe injury.</p>
	<p><b>CAUTION</b></p> <p>Failure to comply with the instructions with this symbol may result in minor or moderate injury.</p>
	<p><b>NOTICE</b></p> <p>Provides information considered important but not hazard-related. The information relates to property damage.</p>
	<p><b>Important</b></p> <p>Indicates valuable tips for optimal installation and operation of the product.</p>

## General Instructions

Be aware that a battery presents a risk of electric shock including high short-circuit current. Follow all safety precautions while operating the batteries.

- Remove watches, rings, and other metallic items.
- Use tools with insulated handles to avoid inadvertent short circuits.
- Wear rubber gloves and safety boots.
- Do not put tools or any metal parts on the top of the batteries.
- Disconnect the charging source and load before connecting or disconnecting terminals.
- Use proper lifting means when moving batteries and wear all appropriate safety clothing and equipment.
- Batteries must be handled, transported and recycled or discarded in accordance with federal, state and local regulations. Do not dispose of the batteries in a fire because they can explode.
- Do not open or mutilate the batteries.
- Only authorized, properly trained and qualified technicians should perform maintenance.
- Only qualified personnel who are familiar with the batteries and safety precautions should install or maintain the battery system.
- Do not allow unauthorized personnel to contact the batteries.

## Safety Precautions

The following precautions are general safety guidelines that should be followed when working with or near the Energy Storage System (ESS). The user should develop complete, site-specific safety parameters and procedures.

- Review and refer to all safety warnings and cautions in this manual before installation.
- Build a clear, permanent, restricted access area around the system.
- Only authorized, properly trained electrical operators should be able to access the system.

The interior of this equipment must be considered a “no-go area except for qualified personnel who are familiar with the batteries and safety precautions.” Consult local codes and applicable rules and regulations to determine permit requirements. If required, mark enclosures appropriately before beginning work.

## Personnel and Equipment Warnings

Personnel in contact with the battery system should be aware of the following hazards:



### WARNING—SHOCK HAZARD

Do not contact system connectors or terminals. Do not open the enclosure doors unless proper lock out and tag out procedures and related trainings are followed in accordance with local codes and regulations.



### WARNING—ARC FLASH HAZARD

All electrical equipment presents an arc flash hazard. There is a serious risk of arc flash relating to any equipment modification, such as opening doors. Serious injuries can occur in arc flash incidents. Appropriate training is required in accordance with local codes and regulations.



### WARNING—FIRE HAZARD

Certain faults may cause a fire.

In case of fire involving electrical equipment, use only carbon dioxide fire extinguishers or those approved for use in fighting electrical fires



### CAUTION—PINCH POINTS

Multiple pinch-points are present in most system components. Be aware that there is a serious risk of injury while working around and in equipment enclosures.



### CAUTION—STATIC SENSITIVE

Electronic devices can be damaged by electrostatic discharge. Proper handling procedures are required. Be sure to wear a grounded anti-static wrist strap and to discharge static electricity by touching a grounded surface near the equipment before touching any system components.

## Dangerous Voltages



### DANGER

The Energy Storage System (ESS) is powered by multiple power sources. Hazardous voltages may be present in the equipment even when it does not appear operational. Make sure that you completely understand the cautions and warnings in this manual. Failure to do so may result in serious injury or death. Follow all manufacturer-published safety procedures.

Electrical equipment can present a risk of electrical shock and can cause arc flash. The following precautions must be observed when working on or around electrical equipment:

- Remove watches, jewelry, rings, and other metallic objects.
- Use tools with insulated handles.
- Safety clothing and shoes must comply with local codes and regulations.

## Lock Out/Tag Out Guidelines



### DANGER

Failure to follow all the applicable lock out/tag out (LOTO) procedures at all times may result in serious injury or death.

With power applied to the ESS, hazardous voltages are present on some components. To prevent death or injury, do not touch any components within the enclosure unless specifically directed to do so. To reduce the risk of electrical shock, make sure that all equipment is properly grounded. For more information, refer to the installation manual.



### WARNING

Enclosure doors must remain closed except when access to the enclosure interior is required. Personnel should keep a safe distance from enclosures whenever the equipment is energized. Always comply with local, state, and national lock out/tag out guidelines when working with or near the ESS. The LOTO procedures must meet or exceed the requirements of all guidelines presented in SAMSUNG SDI safety documentation. Follow these steps before entering potentially hazardous areas or beginning work on the ESS:

- Wear protective clothing and shoes-
- Identify and isolate all power and stored energy sources.
- Apply appropriate LOTO devices. When applying LOTO to the ESS, do not touch anything within the enclosure except as specifically directed in the work procedures.
- Complete the site-specific LOTO procedure and safety checklist before beginning work.

## General Warnings



### DANGER

When energized, this equipment presents a hazard of electric shock, death, and injury. Only authorized, properly trained personnel who are thoroughly familiar with the equipment and should install, operate, or maintain this equipment.



### DANGER

To avoid death, injury, and property damage, follow all safety procedures promulgated by Environmental Health and Safety (EHS) guidelines.



### DANGER

To minimize the hazards of electrical shock, death, and injury, approved grounding practices and procedures must be strictly followed.



### WARNING

To avoid injury and equipment damage, personnel must adhere to the site protocol concerning working at heights.



### WARNING

To avoid personal injury or equipment damage caused by equipment malfunction, only properly and qualified trained personnel should modify any programmable machine.



### WARNING

Always ensure that applicable standards and regulations are followed and only properly certified equipment is used as a critical component of a safety system. Never assume that a safety-critical control loop is functioning correctly.







# Table of Contents

<b>Important Safety Instructions .....</b>	<b>i</b>
General Instructions .....	ii
Safety Precautions .....	ii
Personnel and Equipment Warnings .....	iii
Dangerous Voltages .....	iii
Lock Out/Tag Out Guidelines .....	iv
General Warnings .....	iv
<b>Table of Contents .....</b>	<b>i</b>
<b>Tables.....</b>	<b>iii</b>
<b>Figures .....</b>	<b>iv</b>
<b>1. About this Manual.....</b>	<b>1</b>
1.1 Purpose .....	1
1.2 Target Audience.....	1
1.3 Organization.....	1
1.4 Revision History.....	2
1.5 Acronyms and Abbreviations.....	3
<b>2. Product Description .....</b>	<b>4</b>
2.1 Major Components .....	4
2.1.1 Battery Module (Type A / Type B).....	5
2.1.2 SMU (String Management Unit) .....	7
2.1.3 SMPS Assembly (Type A / Type B).....	10
2.1.4 Rack Frame .....	15
<b>3. Battery System Operation .....</b>	<b>16</b>
3.1 Indicator LED.....	16
3.2 Dry Contact Signals.....	18
3.3 Operation Status.....	22
3.3.1 Normal Status.....	32
3.3.2 Minor Protection Status (Alarm).....	32
3.3.3 Major Protection Status (Fault).....	32
<b>4. Maintenance Checks.....</b>	<b>33</b>
4.1 Daily Checks .....	33
4.2 Monthly Checks .....	33
4.3 Annual Check.....	33
4.4 Maintenance Checklist.....	34
<b>5. Troubleshooting, Repair and Replacement.....</b>	<b>35</b>
5.1 Troubleshooting.....	38
5.1.1 Overvoltage Protection – Cell (Major Protection) .....	38
5.1.2 Undervoltage Protection – Cell (Major Protection).....	38
5.1.3 Overvoltage Protection – Rack (Major Protection) .....	39
5.1.4 Undervoltage Protection – Rack (Major Protection) .....	39
5.1.5 Voltage Imbalance (Major Protection) .....	39
5.1.6 Voltage Sensing Error (Minor Protection) .....	40
5.1.7 Overtemperature Protection (Major Protection) .....	40
5.1.8 Undertemperature Protection (Minor Protection).....	40
5.1.9 Temperature Imbalance (Major Protection) .....	40
5.1.10 Overcurrent Protection (Charge) (Major Protection) .....	41
5.1.11 Overcurrent Protection (Discharge) (Major Protection) .....	41
5.1.12 Communication Failure (Module ↔ Rack) (Major Protection) .....	41
5.1.13 Communication Failure (Rack ↔ System) (Major Protection).....	41
5.1.14 Communication Failure (System BMS ↔ Monitoring Software).....	43
5.1.15 MCCB Failure (Minor Protection).....	43
5.1.16 MCCB Sensor Failure (Minor Protection) .....	43
5.1.17 Current Sensing Error (Minor Protection) .....	43
5.1.18 Fuse Failure (Minor Protection).....	44
5.1.19 BMS Power is Off.....	44
5.1.20 MCCB Handle Cannot be Set to “On” .....	44
5.2 Repair Procedures .....	45
5.2.1 Module BMS Connection Check .....	45
5.2.2 SMU Connection Check .....	47
5.2.3 SMPS Assembly Connection Check.....	49

5.2.4	Busbar Connection Check.....	53
5.2.5	Cell Voltage Balancing.....	54
5.2.6	System Reset .....	55
5.2.7	MCCB Handle Control .....	55
5.3	Replacement Procedures.....	57
5.3.1	Wire Harness Replacement.....	58
5.3.2	Battery Module Replacement .....	64
5.3.3	Rack Fuse / Module Fuse Replacement .....	73
5.3.4	SMU Replacement .....	76
5.3.5	SMPS Assembly Replacement.....	82
5.3.6	Module BMS Replacement.....	92
<b>6.</b>	<b>Appendix.....</b>	<b>94</b>
6.1	Disposal and Recycling .....	94

# Tables

Table 2-1: Extra Auxiliary Breaker Switch Connector Description.....	8
Table 2-2: Terminal Block Description.....	9
Table 2-3: RS485 Connector Description.....	12
Table 2-4: TCP/IP Connector Description .....	12
Table 2-5: Dry Contact Connector Description .....	13
Table 2-6: AC Terminal Description (3 phase).....	13
Table 2-7: AC Terminal Description (1 phase).....	13
Table 3-1: Indicator LED Status.....	16
Table 3-2: Indicated Codes .....	17
Table 3-3: Dry Contact Connector Information.....	18
Table 3-4: Dry Contact Connector Description (Option 1. Customer ID = 0).....	19
Table 3-5: Dry Contact Operation (Option 1. Customer ID = 0) .....	19
Table 3-6: Dry Contact Connector Description (Option 2. Customer ID = 1).....	20
Table 3-7: Dry Contact Operation (Option 2. Customer ID = 1) .....	20
Table 8: Dry Contact Connector Description (Option 3. Customer ID = 2).....	21
Table 9: Dry Contact Operation (Option 3. Customer ID = 2).....	21
Table 3-10: Range of Operation (136S Configuration).....	22
Table 3-11: Range of Operation (128S Configuration).....	23
Table 3-12: Range of Operation (112S Configuration).....	24
Table 3-13: Range of Operation (104S Configuration).....	25
Table 3-14: Range of Operation (80S Configuration) .....	26
Table 3-15: Protective Functions (136S Configuration) .....	27
Table 3-16: Protective Functions (128S Configuration) .....	28
Table 3-17: Protective Functions (112S Configuration) .....	29
Table 3-18: Protective Functions (104S Configuration) .....	30
Table 3-19: Protective Functions (80S Configuration) .....	31
Table 4-1: Maintenance Checklist Template.....	34
Table 5-1: Recommended Tools and Instruments for Repair and Replacement.....	35

# Figures

Figure 2-1: Battery Module Type A .....	5
Figure 2-2: Battery Module Type B .....	6
Figure 2-3: SMU .....	7
Figure 2-4: Auxiliary Breaker Switch .....	8
Figure 2-5: Terminal Block Isometric View .....	8
Figure 2-6: Terminal Block Front / Top View (Cover Opened/Closed) .....	9
Figure 2-7: SMPS Assembly .....	10
Figure 2-8: Front View of SMPS Assembly Type A, 3-Phase Input .....	11
Figure 2-9: Front View of SMPS Assembly Type A, 1-Phase Input .....	11
Figure 2-10: SMPS Assembly Type A – System BMS Connections .....	11
Figure 2-11: Front View of SMPS Assembly Type B, 1-Phase Input .....	11
Figure 2-12: Rack Frame .....	15
Figure 3-1: Dry Contact Connector Pinout .....	18
Figure 5-1. System BMS LED .....	42
Figure 5-2: Signal Connectors .....	45
Figure 5-3: Removing the Battery Module Front Cover .....	46
Figure 5-4: Voltage and Temperature Sensing Connectors .....	46
Figure 5-5: DC Power Cables from SMPS Assembly Type A to SMU .....	47
Figure 5-6: DC Power Cables from SMPS Assembly Type B to SMU .....	47
Figure 5-7: CAN Signal Cable Connection from SMPS Assembly to SMU .....	48
Figure 5-8: Signal Cabling Examples of Left Alignment of SMUs .....	48
Figure 5-9: Termination resistor setting .....	49
Figure 5-10: DC Power Cables from SMPS Assembly Type A to SMU .....	49
Figure 5-11: DC Power Cables from SMPS Assembly Type B to SMU .....	50
Figure 5-12: CAN Signal Cable Connection from SMPS Assembly to SMU .....	50
Figure 5-13: Dry Contact Cable Connection to SMPS Assembly .....	50
Figure 5-14: AC Input Terminals .....	51
Figure 5-15: AC Input Terminals with Cables Attached .....	51
Figure 5-16: AC Input Terminals Protective Covers .....	52
Figure 5-17: Remove the front covers .....	53
Figure 5-18: Reattach the Front Covers .....	54
Figure 5-19: Pressing the Reset Button .....	55
Figure 5-20: MCCB Handle in Trip Position .....	56
Figure 5-21: MCCB Handle in Off Position .....	56
Figure 5-22: MCCB Handle in On Position .....	56
Figure 5-23: Remove SMU to Module #1 Right Connector .....	58
Figure 5-24: Install Signal Cable Between the SMU and Battery Module #1 Right Connector .....	59
Figure 5-25: Remove Module to Module Signal Cable .....	59
Figure 5-26: Install Module to Module Signal Cable .....	60
Figure 5-27: CAN Wire Harness Between SMU Assemblies .....	60
Figure 5-28: CAN Cable Connection from SMPS Assembly to SMU .....	61
Figure 5-29: MCCB Handle in “OFF” position .....	62
Figure 5-30: DC Power Cables from SMPS Assembly Type A to SMU .....	62
Figure 5-31: DC Power Cables from SMPS Assembly Type B to SMU .....	62
Figure 5-32: MCCB Handle in “ON” Position .....	63
Figure 5-33: Removing the Battery Module Front Cover .....	65
Figure 5-34: Battery Module Type A .....	65
Figure 5-35: Battery Module Type B .....	66
Figure 5-36: MCCB Handle in “OFF” Position .....	66
Figure 5-37: Remove Battery Module Front Covers .....	66
Figure 5-38: Measuring Each Battery Module’s Voltage .....	67
Figure 5-39: Assemble Battery Module Front Covers .....	67
Figure 5-40: DC Power Supply and Battery Module Connection .....	68
Figure 5-41: Battery Module Signal Cables .....	69

Figure 5-42: Remove Battery Module Front Covers.....	69
Figure 5-43: Busbars on Positive and Negative Terminals.....	69
Figure 5-44: Hook and slots on the rack frame.....	70
Figure 5-45: Inserting the Replacement Battery Module.....	71
Figure 5-46: Removing the Front Covers.....	71
Figure 5-47: Busbars.....	71
Figure 5-48: Reattaching the Front Cover to the Battery Module.....	72
Figure 5-49: Connecting the Signal Cables.....	72
Figure 5-50: MCCB Handle in “ON” Position.....	72
Figure 5-51: MCCB Handle in “OFF” Position.....	73
Figure 5-52: Remove the Battery Module Front Covers.....	74
Figure 5-53: MCCB Handle in “ON” Position.....	74
Figure 5-54: MCCB Handle in “OFF” Position.....	76
Figure 5-55: DC IN Cable.....	76
Figure 5-56: CAN Cable to SMPS Assembly.....	76
Figure 5-57: CAN Cable to Adjacent Rack.....	77
Figure 5-58: Module Signal Cable.....	77
Figure 5-59: SMU Terminal Covers.....	77
Figure 5-60: P+, P- Terminals.....	78
Figure 5-61: B+, B-, P+, P- Terminal Connections and Terminal Covers.....	79
Figure 5-62: SMU to Module Signal Cable.....	79
Figure 5-63: SMU to SMPS Assembly CAN Signal Cable.....	80
Figure 5-64: DC Power Cables from SMPS Assembly Type A to SMU.....	80
Figure 5-65: DC Power Cables from SMPS Assembly Type B to SMU.....	80
Figure 5-66: MCCB Handle in “ON” Position.....	81
Figure 5-67: MCCB Handle in “OFF” Position.....	82
Figure 5-68: AC Input Terminals.....	82
Figure 5-69: Cables to the AC Input Terminals.....	83
Figure 5-70: DC OUT Connection.....	83
Figure 5-71: BMS CAN Connection.....	83
Figure 5-72: TCP/IP Connection.....	85
Figure 5-73: Dry Contact Connection.....	85
Figure 5-74: Unscrew SMPS Assembly.....	85
Figure 5-75: Unscrew SMPS Assembly Grounding Cable.....	86
Figure 5-76: Remove the SMPS Assembly.....	86
Figure 5-77: Insert the SMPS Assembly.....	86
Figure 5-78: Screw on the SMPS Assembly.....	87
Figure 5-79: Screw on the SMPS Assembly Grounding Cable.....	87
Figure 5-80: DC Power Cables from SMPS Assembly Type A to SMU.....	88
Figure 5-81: DC Power Cables from SMPS Assembly Type B to SMU.....	88
Figure 5-82: BMS CAN Cable from SMPS Assembly to SMU.....	89
Figure 5-83: TCP/IP Cable.....	89
Figure 5-84: Dry Contact Cable.....	89
Figure 5-85: AC Input Terminals.....	90
Figure 5-86: AC Input Terminals with Cables Attached.....	90
Figure 5-87: AC Input Terminals Protective Cover.....	91
Figure 5-88: MCCB Handle in “ON” Position.....	91





# 1. About this Manual

This section briefly describes the purpose, audience, organization, revision history, and acronyms and abbreviations used in this document.

## 1.1 Purpose

The purpose of this manual is to provide information for the safe and successful operation and maintenance of the product.

## 1.2 Target Audience

This manual is intended for system administrators and operators who install, operate, maintenance and configure the product.

## 1.3 Organization

This manual is composed of the following chapters:

- Chapter 1, “About this Manual” introduces preliminary description about this document.
- Chapter 2, “Product Description” describes the major components of the product.
- Chapter 3, “Battery System Operation” explains the operation modes of the battery system.
- Chapter 4, “Maintenance Check” lists items to inspect daily, monthly, and annually.
- Chapter 5, “Troubleshooting” guides the reader through clearing protection modes and replacing components.

## 1.4 Revision History

Rev.	Description	Author	Date
0.0	First Draft (tentative release)		2019.08.20

Approved By:		
Name	Signature	Date

Trusted Reviewers		
Name	Signature	Date

## 1.5 Acronyms and Abbreviations

The following acronyms and abbreviations are used in this manual.

Abbreviations	Full Name
AED	Automated External Defibrillator
BMS	Battery Management System
Comm.	Communication
EHS	Environmental Health and Safety
ESS	Energy Storage System
LOTO	LOCK OUT/TAG OUT
OT	Overtemperature
OVP	Overvoltage Protection
SMPS	Switched Mode Power Supply
SMU	String Management Unit
SOC	State Of Charge
SOH	State Of Health
UT	Undertemperature
UVP	Undervoltage Protection
UPS	Uninterruptible Power Supply

## 2. Product Description

Before operating the battery system, users must be familiar with its components.

### 2.1 Major Components

Samsung SDI's Lithium Ion Battery System has the following components:

- Battery Module (Type A / Type B)
- SMU
- Rack BMS (Embedded in SMU)
- Rack Frame
- SMPS Assembly (Type A / Type B)
- System BMS (Embedded in SMPS Assembly Type A)

Refer to the "Product Specification" document for detailed specifications of the components.

### 2.1.1 Battery Module (Type A / Type B)

Battery Module is the most basic component of the Battery System and it contains the energy storing battery cells. There is a Module BMS inside each Battery Module. Module BMS checks the status of a Battery Module by measuring its voltage and temperature. It also communicates with the SMU to send all measured voltage and temperature data, and to receive commands to control cell balancing.

There are two types of 8S1P Battery Module depending on the position of terminal's polarity. Type A's plus(+) terminal is on the right side. Type B is on the left.

Type A: EM2031AE00XA (X = 1, 3)

X = 1 for specific customer (customer SKU serial number barcode + SDI serial number barcode)

X = 3 for general customer (SDI serial number barcode only)

Type B: EM2031AE00YA (Y = 2, 4)

Y = 2 for specific customer (customer SKU serial number barcode + SDI serial number barcode)

Y = 4 for general customer (SDI serial number barcode only)

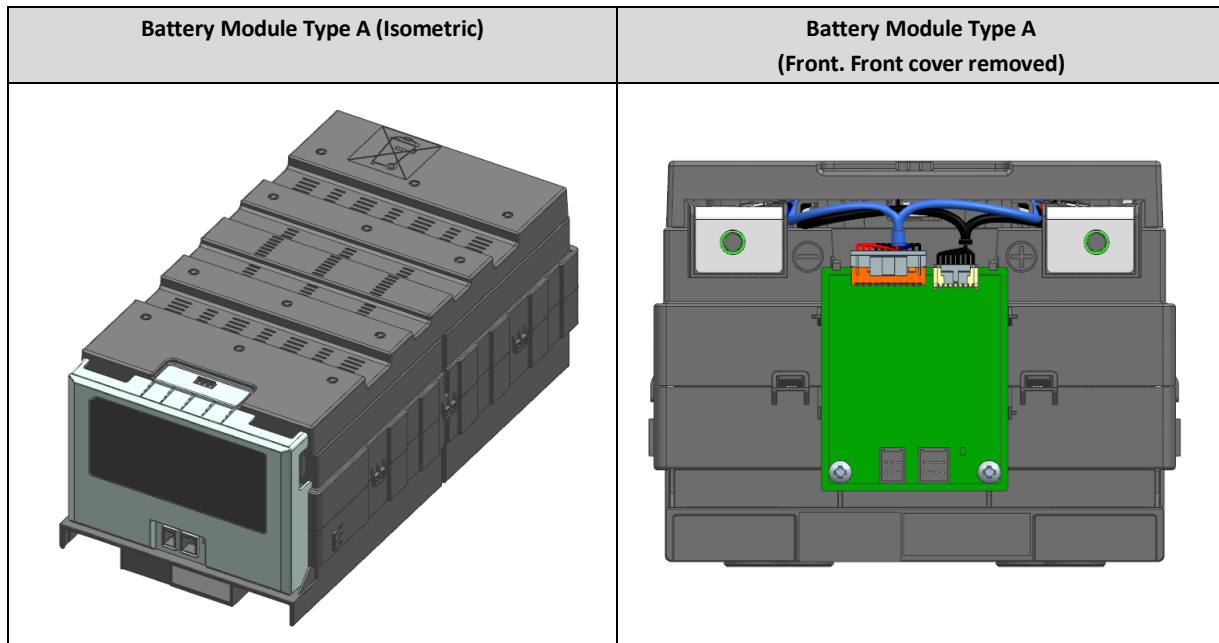

Figure 2-1: Battery Module Type A

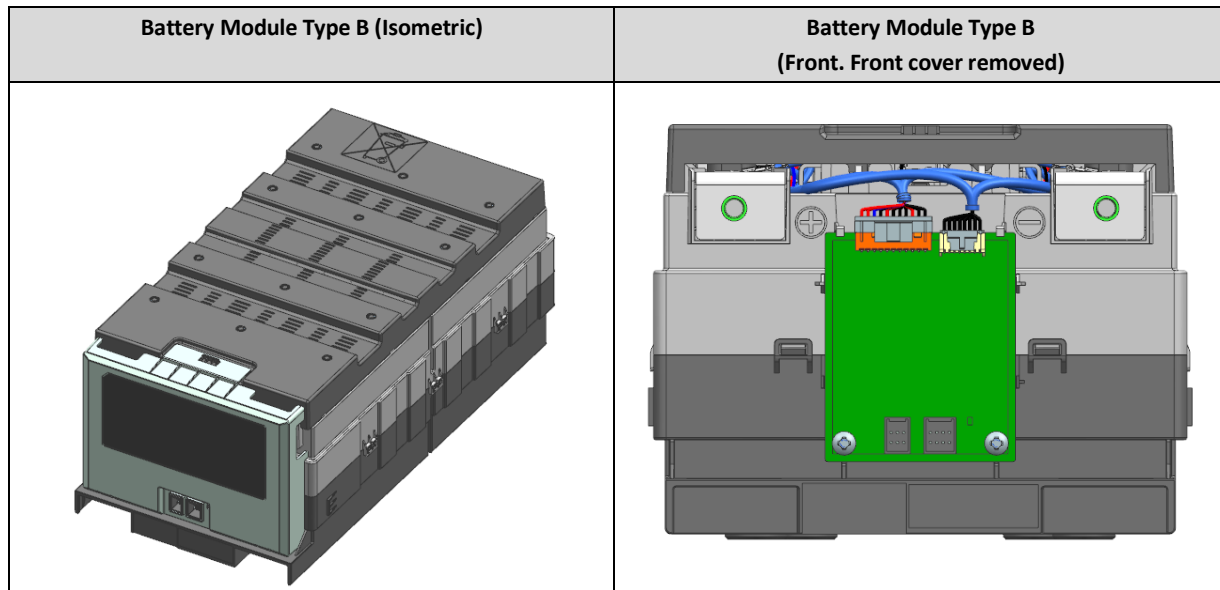

Figure 2-2: Battery Module Type B

### 2.1.2 SMU (String Management Unit)

SMU collects all information about the battery system and controls the battery system by switching the main power line and controls each Battery Module by cell balancing. SMU calculates the state-of-charge (SOC) and state-of-health (SOH) of the battery system. Key components in the SMU are Rack BMS, MCCB, and shunt resistor. Rack BMS is the main controller that takes all data from the Module BMS, measures the string voltage and current, determines the state of the battery and controls the MCCB accordingly.

UL: V049-0011XA (X = A, B)

CE: V049-0012XA (X = A, B)

X = A for general customer (SDI serial number barcode only)

X = B for specific customer (customer SKU serial number barcode + SDI serial number barcode)

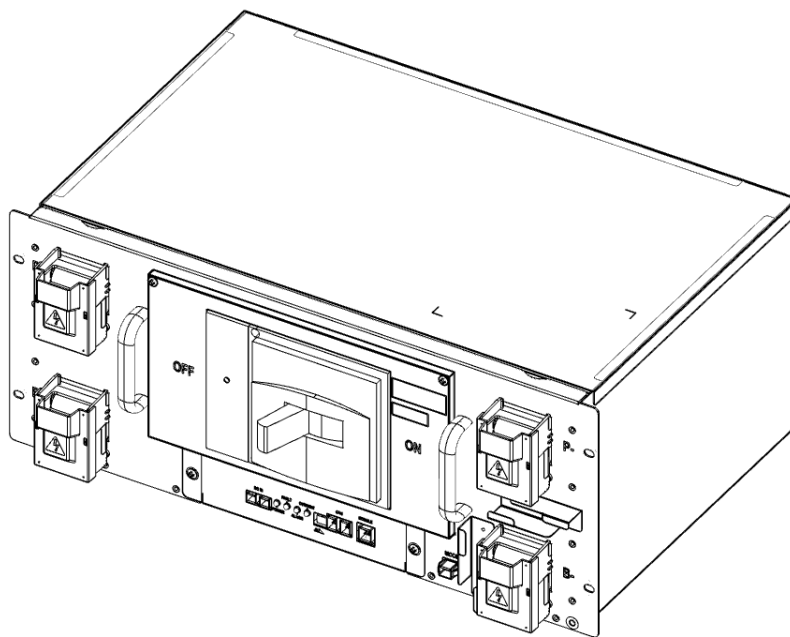

Figure 2-3: SMU

SMU provides an auxiliary breaker switch that can be connected to the building monitoring system.

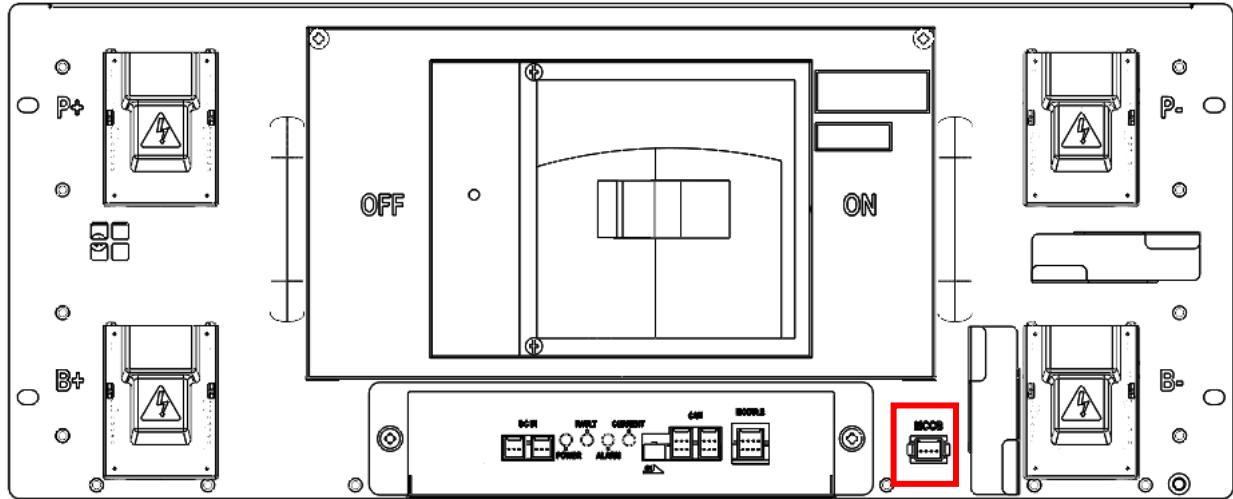

Figure 2-4: Auxiliary Breaker Switch

Table 2-1: Extra Auxiliary Breaker Switch Connector Description

Item	Part Name	Description
Connector	J21SPM-04V-KX	-
Harness Housing	J21SF-04V-KX-L	-
Harness Terminal	SJ2F-01GF-P1.0	AWG 20~24
Pin No.	Pin Name	Function
1	Normal Open	
2	Common	
3	Normal Close	
4	-	

P+ and P- terminal blocks connect to the DC link from the UPS. Cable and lug terminals should be selected according to the terminal block's size and material.



Figure 2-5: Terminal Block Isometric View



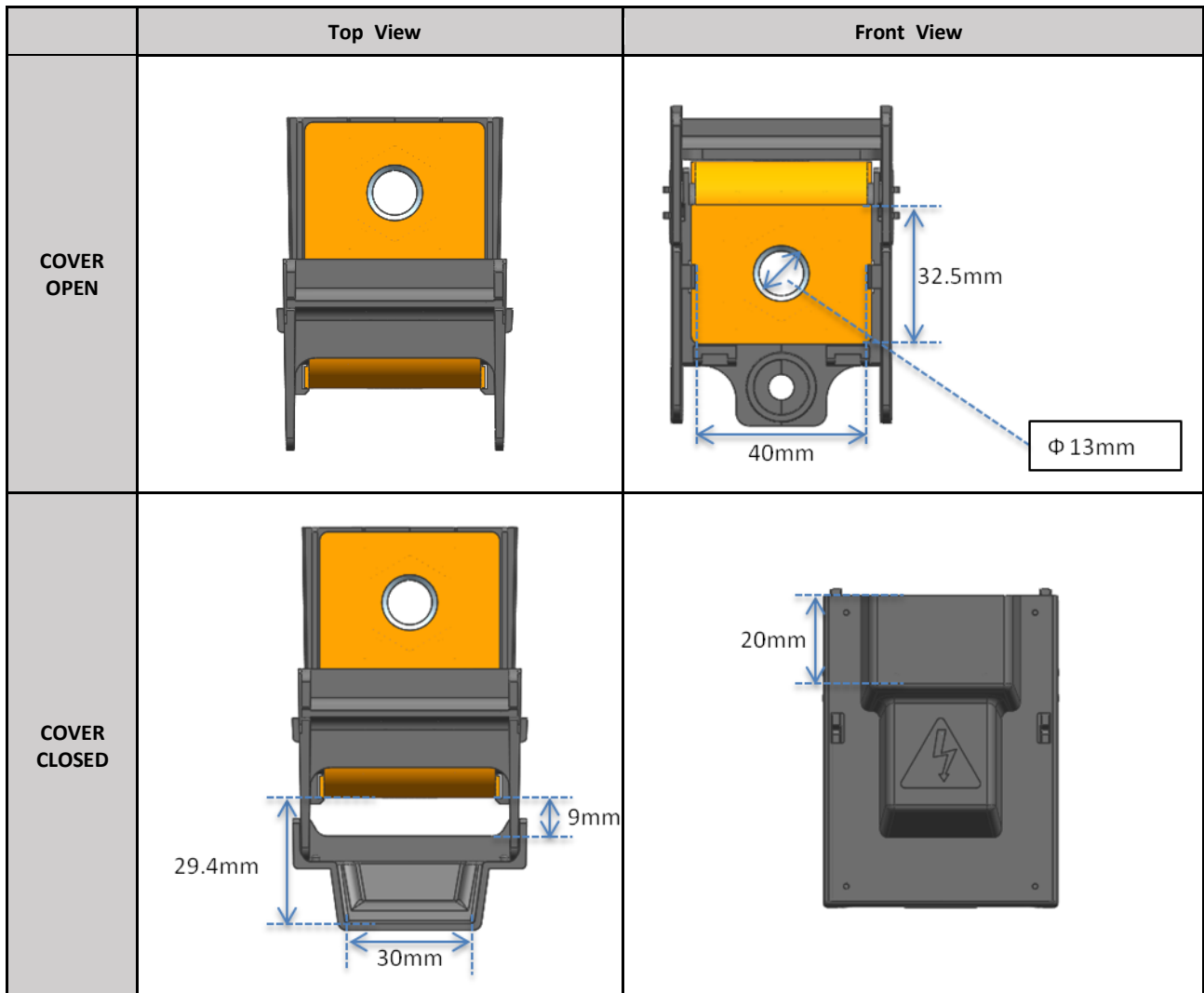

Figure 2-6: Terminal Block Front / Top View (Cover Opened/Closed)

Table 2-2: Terminal Block Description

Item	Detail	Description
Conducting Material	Cu	C1100
Insulating Material (Guide)	PA66	GF25%
Insulating Material (Cover)	PC	
Conductive Area	32.5mm x 40.0mm	
Rated Current	473A	Calculated in accordance with DIN 43670 MELSON & BOTH equation

**2.1.3 SMPS Assembly (Type A / Type B)**

3-Phase Type A (with System BMS): V044-0006XA

X = A (for general customer)

X = B (for specific customer)

3-Phase Type B (without System BMS): SJ94-00238B (for general customer)

1-Phase Type A (with System BMS): V044-0004XA

X = A (for general customer)

X = B (for specific customer)

1-Phase Type B (without System BMS): V044-0005AA (for general customer)

SMPS Assembly houses the System BMS and SMPS, which provides power to the System BMS and SMU. Two options are available for the SMPS depending on the AC input range and cabling: 3 phase and 1 phase. The System BMS assembly provides data to the external systems (i.e. building management system, UPS, etc.) while controlling and monitoring all connected Rack BMS.

There are two types of SMPS Assembly: Type A is with System BMS and Type B is without System BMS.

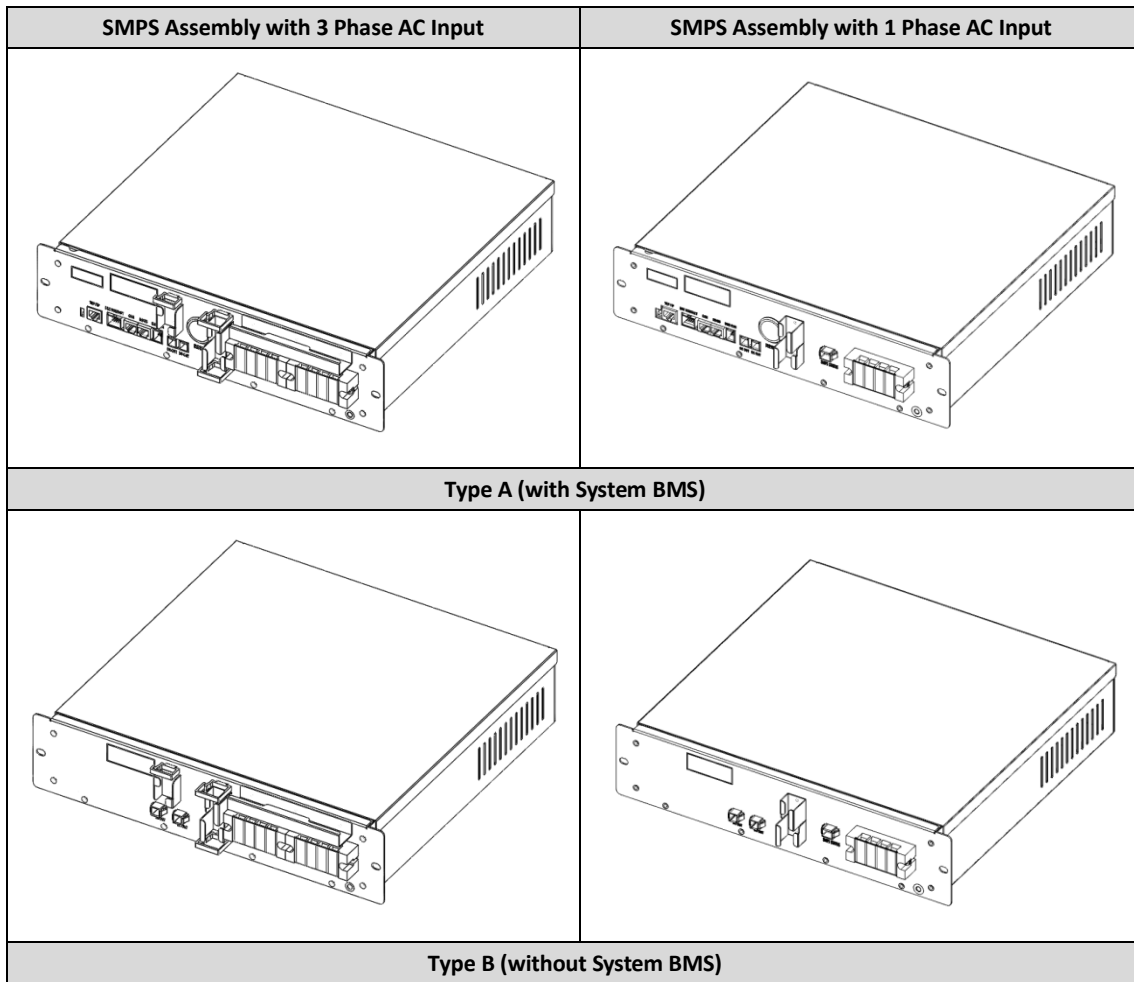

Figure 2-7: SMPS Assembly

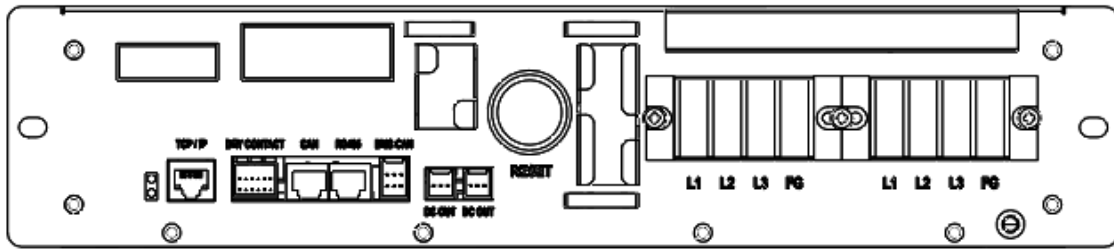

Figure 2-8: Front View of SMPS Assembly Type A, 3-Phase Input

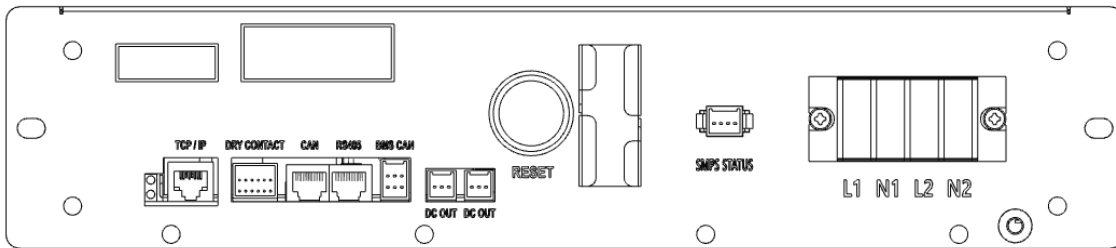

Figure 2-9: Front View of SMPS Assembly Type A, 1-Phase Input

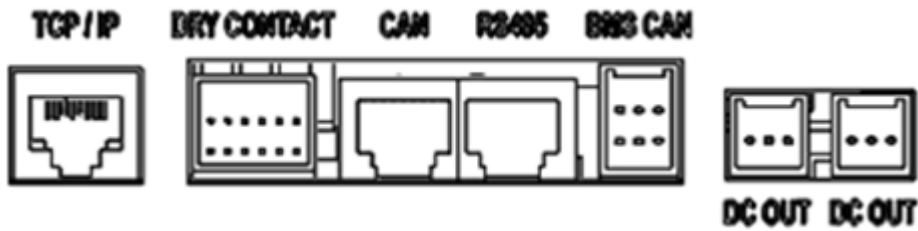

Figure 2-10: SMPS Assembly Type A – System BMS Connections

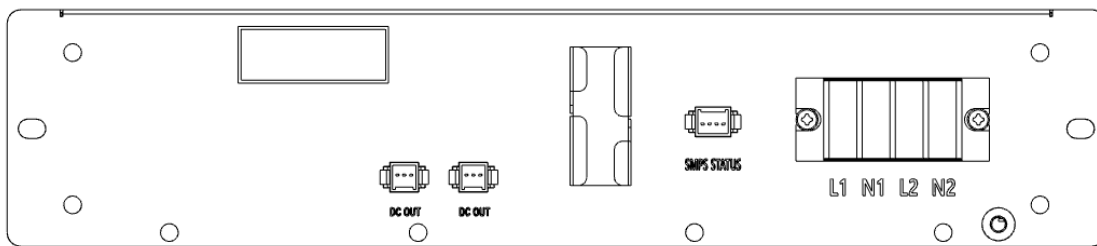

Figure 2-11: Front View of SMPS Assembly Type B, 1-Phase Input

SMPS Assembly Type A provides RS485, TCP/IP and Dry contact.

Table 2-3: RS485 Connector Description

Item	Part Name	Description
Connector	IM25G-008-256	2 Port, RJ45
Harness Housing	RJ45	-
Harness Terminal	RJ45	-
Pin No.	Pin Name	Function
Left. 1	CAN port	For debugging purpose only
Left. 2		
Left. 3		
Left. 4		
Left. 5		
Left. 6		
Left. 7		
Left. 8		
Right. 1	RS485 A	Rx+ (Short to Tx+ externally)
Right. 2	RS485 B	Rx- (Short to Rx- externally)
Right. 3	RS485 Z	Tx- (Short to Rx- externally)
Right. 4	-	
Right. 5	-	
Right. 6	RS485 Y	Tx+
Right. 7	-	
Right. 8	GND	

Table 2-4: TCP/IP Connector Description

Item	Part Name	Description
Connector	VS-08-BU-RJ45/LP-1	PHOENIX CONTACT
Harness Housing	RJ45	-
Harness Terminal	RJ45	-
Pin No.	Pin Name	Function
1	TX+	TCP/IP TX+
2	TX-	TCP/IP TX-
3	RX+	TCP/IP RX+
4	GND	GND
5	GND	GND
6	RX-	TCP/IP RX-
7	GND	GND
8	GND	GND

Table 2-5: Dry Contact Connector Description

Item	Part Name	Description
Connector	S12B-J11DK-TXR	JST
Harness Housing	J11DF-12V-KX	-
Harness Terminal	SF1F-21T-P0.6	AWG 18~22
Pin No.	Pin Name	Function
1A	DRY CONTACT 0 NC	Refer to the product specification.
2A	DRY CONTACT 1 COM	
3A	DRY CONTACT 1 NO	
4A	DRY CONTACT 2 NC	
5A	-	
6A	DRY CONTACT IN- (GND)	
1B	DRY CONTACT 0 COM	
2B	DRY CONTACT 0 NO	
3B	DRY CONTACT 1 NC	
4B	DRY CONTACT 2 COM	
5B	DRY CONTACT 2 NO	
6B	DRY CONTACT IN+	

Table 2-6: AC Terminal Description (3 phase)

Item	Part Name	Description
Terminal Block	SL3T-4P	Seoil Electronics
Terminals	Ring terminal	320 ~ 575VAC, 6A
Pin No.	Pin Name	Function
1	L1	3 phase AC, L1
2	L2	3 phase AC, L2
3	L3	3 phase AC, L3
4	PE	-

Table 2-7: AC Terminal Description (1 phase)

Item	Part Name	Description
Terminal Block	SL3T-4P	Seoil Electronics
Terminals	Ring terminal	100 ~ 240VAC, 6A
Pin No.	Pin Name	Function
1	L1	SMPS #1 1 phase AC, L
2	N1	SMPS #1 1 phase AC, N
3	L2	SMPS #2 1 phase AC, L
4	N2	SMPS #2 1 phase AC, N

SMPS Assembly with 1 phase AC input has auxiliary connectors for the status of the SMPS.

Table 8: SMPS Status (SMPS Assembly 1 Phase Only)

Item	Part Name	Description
Connector	J21SPM-04V-KX	-
Harness Housing	J21SF-04V-KX-L	-
Harness Terminal	SJ2F-01GF-P1.0	AWG 20~24
Pin No.	Pin Name	Function
1	SMPS #1 STATUS (+)	SMPS #1 status
2	SMPS #1 STATUS (-)	SMPS #1 status
3	SMPS #2 STATUS (+)	SMPS #2 status
4	SMPS #2 STATUS (-)	SMPS #2 status

### 2.1.4 Rack Frame

White: V808-00066A

Black: V808-00068A

The Rack Frame is used to mount the modules, SMU and SMPS assembly and provides ground connections for SMU and SMPS Assembly.

(Grounding cable/busbar for the rack frame is necessary for the SMU and SMPS Assembly as they are grounded to the rack frame when installed. An equipment grounding conductor is required to ground the rack frames together and to the UPS module).

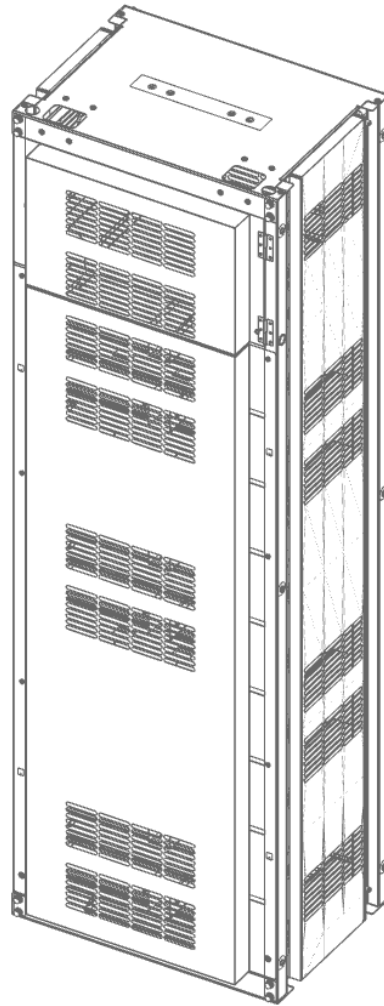

Figure 2-12: Rack Frame

## 3. Battery System Operation

The battery system for a UPS is designed to be always on. The UPS and the critical load must be set up so that the battery system's maximum allowable voltage and current are not exceeded.

### 3.1 Indicator LED

Four indicator LED's on the front of the SMU in each rack displays the status of the battery system per string. Table 3-1 shows each LED's color and the battery status indicated.

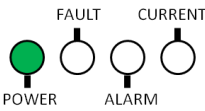
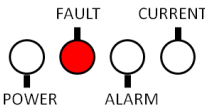
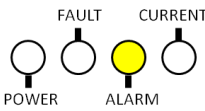
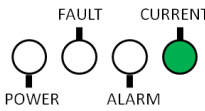
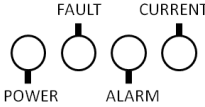
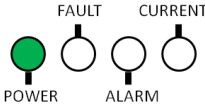
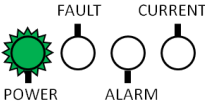
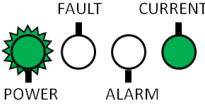
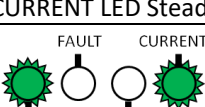
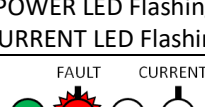

Table 3-1: Indicator LED Status

Items	POWER(Green)	FAULT(Red)	ALARM(Yellow)	CURRENT(Green)
Location				
Status	On : MCCB Off Off : Power Off Blink : MCCB On	On : N/A Off : No Major Protection Blink : Major Protection	On : N/A Off : No Minor Protection Blink : Minor Protection	On : Discharge Off : Idle Blink : Charge



Depending on the battery system’s operating conditions, each indicator LED may be on, blinking or off. Table 3-2 shows the LED indication for the battery status.

Table 3-2: Indicated Codes

LED Status	Battery Status	Remarks
 <p>All LED's Off</p>	BMS Power Off	MCCB Off
 <p>POWER LED Steady</p>	Normal	MCCB Off
 <p>POWER LED Flashing</p>	Normal	MCCB On
 <p>POWER LED Flashing CURRENT LED Steady</p>	Normal	Discharge
 <p>POWER LED Flashing CURRENT LED Flashing</p>	Normal	Charge
 <p>POWER LED Steady FAULT LED Flashing</p>	Major Protection MCCB Tripped	Overvoltage Protection Undervoltage Protection Overtemperature Protection Overcurrent Protection
 <p>POWER LED Flashing ALARM LED Flashing</p>	Minor Protection MCCB On	Voltage Imbalance Error Voltage Sensing Error Undertemperature Protection Temperature Imbalance Error

### 3.2 Dry Contact Signals

Dry contact signals are sent from the System BMS in the SMPS Assembly to let the UPS know the status of the battery system. Three Form-C output channels send signals for major protection, minor protection, and charge stop request. One input channel receives a signal to trip the MCCB when requested from the UPS.

Three options of dry contact operation can be selected during installation.

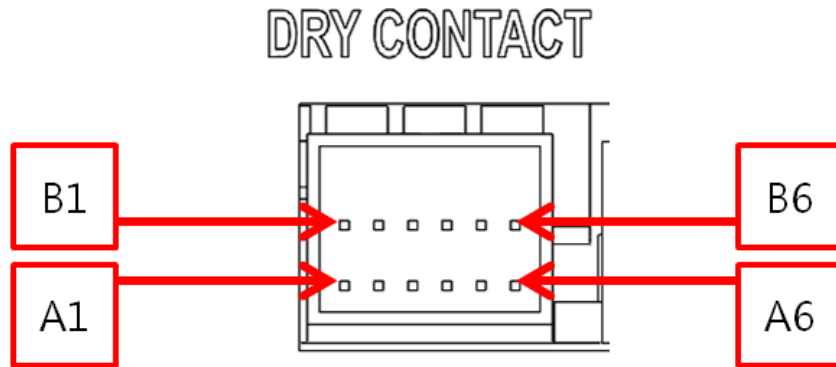

Figure 3-1: Dry Contact Connector Pinout

Table 3-3: Dry Contact Connector Information

Item	Part Name	Description
Connector	S12B-J11DK-GWXR	JST
Harness Housing	J11DF-12V-KX	JST

Table 3-4: Dry Contact Connector Description (Option 1. Customer ID = 0)

Pin No.	Pin Name	Function
B1	Major Common	Over-Voltage Protection Under-Voltage Protection Over-Temperature Protection Over-Current Protection
A1	Major Normal Close	
B2	Major Normal Open	
A2	Minor Common	Voltage Imbalance Error Voltage Sensing Error Under Temperature protection Temperature Imbalance Error
B3	Minor Normal Close	
A3	Minor Normal Open	
B4	Charge Common	Charge Stop Set Condition 1. Overvoltage alarm(4.25V/Cell) 2. SOC 100% Charge Stop Release Condition 1. SOC < 97% or Discharge Current >  3A
A4	Charge Normal Close	
B5	Charge Normal Open	
A5	Reserved	
B6	Input	Set Condition: UPS <b>closes</b> B6, A6 contacts for more than 3 second. Action : Battery MCCB Trip
A6	GND	

Table 3-5: Dry Contact Operation (Option 1. Customer ID = 0)

Battery Status	MAJOR			MINOR			CHARGE STOP		
	B1	A1	B2	A2	B3	A3	B4	A4	B5
Normal Status	COM	Open	Close	COM	Open	Close	COM	Open	Close
Major Protection	COM	Close	Open	COM	Open	Close	COM	Open	Close
Minor Protection	COM	Open	Close	COM	Close	Open	COM	Open	Close
Charge Stop	COM	Open	Close	COM	Open	Close	COM	Close	Open
BMS Power Off	COM	Close	Open	COM	Close	Open	COM	Close	Open

Table 3-6: Dry Contact Connector Description (Option 2. Customer ID = 1)

Pin No.	Pin Name	Function
B1	Major Common	Overvoltage Protection Undervoltage Protection Overtemperature Protection Overcurrent Protection
A1	Major Normally Closed	
B2	Major Normally Open	
A2	Minor Common	Voltage Imbalance Error Voltage Sensing Error Undertemperature Protection Temperature Imbalance Error
B3	Minor Normally Closed	
A3	Minor Normally Open	
B4	MCCB Status Common	All MCCB's are Off : A4, B4 are closed. One of the MCCB's is on : B5, B4 are closed.
A4	MCCB Status Normally Closed	
B5	MCCB Status Normally Open	
A5	Reserved	—
B6	Input	Set Condition: UPS opens B6, A6 contacts for more than 3 seconds. Action : Battery MCCB Trip
A6	GND	

Table 3-7: Dry Contact Operation (Option 2. Customer ID = 1)

Battery Status	MAJOR			MINOR			MCCB Status		
	B1	A1	B2	A2	B3	A3	B4	A4	B5
Normal Status	COM	Open	Close	COM	Open	Close	COM	Open	Close
Major Protection	COM	Close	Open	COM	Open	Close	COM	Close	Open
Minor Protection	COM	Open	Close	COM	Close	Open	COM	Open	Close
MCCB Off	COM	Close	Open	COM	Open	Close	COM	Close	Open
BMS Power Off	COM	Close	Open	COM	Close	Open	COM	Close	Open

Table 8: Dry Contact Connector Description (Option 3. Customer ID = 2)

Pin No.	Pin Name	Function
B1	Discharge Prohibit Common	Undervoltage Protection Overtemperature Protection Discharge Overcurrent Protection
A1	Discharge Prohibit Normal Close	
B2	Discharge Prohibit Normal Open	
A2	Charge Prohibit Common	Overvoltage Alarm, Overvoltage Protection Overtemperature Protection Charge Overcurrent Protection
B3	Charge Prohibit Normal Close	
A3	Charge Prohibit Normal Open	
B4	MCCB Status Common	All MCCBs are off : 4A, 4B is closed One of MCCB is on : 5B, 4B is closed
A4	MCCB Status Normal Close	
B5	MCCB Status Normal Open	
A5	Reserved	
B6	Input	Set Condition: UPS <b>opens</b> B6, A6 contacts for more than 1 second. Action : Battery MCCB Trip
A6	GND	

Table 9: Dry Contact Operation (Option 3. Customer ID = 2)

Battery Status	Discharge Prohibited			Charge Prohibited			MCCB Status		
	B1 (COM)	A1 (NC)	B2 (NO)	A2 (COM)	B3 (NC)	A3 (NO)	B4 (COM)	A4 (NC)	B5 (NO)
Normal Status (All MCCB on)	COM	Close	Open	COM	Close	Open	COM	Open	Close
At least one MCCB is on	COM	-	-	COM	-	-	COM	Open	Close
Discharge Prohibited (UVP, OTP, Discharge OCP)	COM	Open	Close	COM	-	-	COM	-	-
Charge Prohibited (OV alarm, OVP, OTP, Charge OCP)	COM	-	-	COM	Open	Close	COM	-	-
All MCCBs Off	COM	-	-	COM	-	-	COM	Close	Open
EPO Received (B6, A6 contacts are OPEN for more than 1 second)	COM	-	-	COM	-	-	COM	Close	Open
BMS Power Off	COM	Close	Open	COM	Close	Open	COM	Close	Open

### 3.3 Operation Status

Refer to the table below for typical and maximum state of charge and discharge conditions to keep the battery system in normal operation.

Table 3-10: Range of Operation (136S Configuration)

No.	Item	Specification	Remarks
1	Nominal Capacity	34.6kWh	1/3C@R.T
2	Nominal Voltage <sup>1</sup>	516.8V DC	3.8V/cell
3	Maximum Voltage <sup>1</sup>	571.2V DC	4.2V/cell
4	Discharging Method	Constant Power	
	End of Discharge Voltage <sup>1</sup>	408V DC	3.0V/cell
	Recommended End of Discharge Voltage	435.2V DC	3.2V/cell
	Standard Discharging Current	22.3A	1/3C@R.T
	Maximum Continuous Discharge Power	183.6kW	Peak 450A @ EODV
5	Charging Method	CC-CV, Floating	
	Floating Charge Voltage	571.2V DC	4.2V/cell
	Standard Charge Current	22.3A	1/3C
	Maximum Peak Charge Current	250A	2 second pulse
	Maximum Continuous Charging Current	67A	1C
6	Recommended Operation Temperature	23±5°C	
7	Storage Temperature	0 ~ 40°C	
8	Storage Humidity	Less than 90 % RH	Noncondensing
9	Recommended Storage Humidity	Less than 60 % RH	Noncondensing
10	Storage Period <sup>2</sup>	Less than 6 months	

<sup>1</sup> Specified voltage must be satisfied in all load and charging conditions.

<sup>2</sup> Capacity degradation will occur depending on storage time. To minimize capacity degradation, storage temperature of less than 10°C and 3.630V per cell is recommended.

Table 3-11: Range of Operation (128S Configuration)

No.	Item	Specification	Remarks
1	Nominal Capacity	32.6kWh	1/3C@R.T
2	Nominal Voltage <sup>1</sup>	486.4V DC	3.8V/cell
3	Maximum Voltage <sup>1</sup>	537.6V DC	4.2V/cell
4	Discharging Method	Constant Power	
	End of Discharge Voltage <sup>1</sup>	384V DC	3.0V/cell
	Recommended End of Discharge Voltage	409.6V DC	3.2V/cell
	Standard Discharging Current	22.3A	1/3C@R.T
	Maximum Continuous Discharge Power	173kW	Peak 450A @ EODV
5	Charging Method	CC-CV, Floating	
	Floating Charge Voltage	537.6V DC	4.2V/cell
	Standard Charge Current	22.3A	1/3C
	Maximum Peak Charge Current	250A	2 second pulse
	Maximum Continuous Charging Current	67A	1C
6	Recommended Operation Temperature	23±5°C	
7	Storage Temperature	0 ~ 40°C	
8	Storage Humidity	Less than 90 % RH	Noncondensing
9	Recommended Storage Humidity	Less than 60 % RH	Noncondensing
10	Storage Period <sup>2</sup>	Less than 6 months	

<sup>1</sup> Specified voltage must be satisfied in all load and charging conditions.

<sup>2</sup> Capacity degradation will occur depending on storage time. To minimize capacity degradation, storage temperature of less than 10°C and 3.630V per cell is recommended.

Table 3-12: Range of Operation (112S Configuration)

No.	Item	Specification	Remarks
1	Nominal Capacity	28.5kWh	1/3C@R.T
2	Nominal Voltage <sup>1</sup>	425.6V DC	3.8V/cell
3	Maximum Voltage <sup>1</sup>	470.4V DC	4.2V/cell
4	Discharging Method	Constant Power	
	End of Discharge Voltage <sup>1</sup>	336V DC	3.0V/cell
	Recommended End of Discharge Voltage	358.4V DC	3.2V/cell
	Standard Discharging Current	22.3A	1/3C@R.T
	Maximum Continuous Discharge Power	151kW	Peak 450A @ EODV
5	Charging Method	CC-CV, Floating	
	Floating Charge Voltage	470.4V DC	4.2V/cell
	Standard Charge Current	22.3A	1/3C
	Maximum Peak Charge Current	250A	2 second pulse
	Maximum Continuous Charging Current	67A	1C
6	Recommended Operation Temperature	23±5°C	
7	Storage Temperature	0 ~ 40°C	
8	Storage Humidity	Less than 90 % RH	Noncondensing
9	Recommended Storage Humidity	Less than 60 % RH	Noncondensing
10	Storage Period <sup>2</sup>	Less than 6 months	

<sup>1</sup> Specified voltage must be satisfied in all load and charging conditions.

<sup>2</sup> Capacity degradation will occur depending on storage time. To minimize capacity degradation, storage temperature of less than 10°C and 3.630V per cell is recommended.



Table 3-13: Range of Operation (104S Configuration)

No.	Item	Specification	Remarks
1	Nominal Capacity	26.5kWh	1/3C@R.T
2	Nominal Voltage <sup>1</sup>	395.2V DC	3.8V/cell
3	Maximum Voltage <sup>1</sup>	436.8V DC	4.2V/cell
4	Discharging Method	Constant Power	
	End of Discharge Voltage <sup>1</sup>	312V DC	3.0V/cell
	Recommended End of Discharge Voltage	332.8V DC	3.2V/cell
	Standard Discharging Current	22.3A	1/3C@R.T
	Maximum Continuous Discharge Power	140kW	Peak 450A @ EODV
5	Charging Method	CC-CV, Floating	
	Floating Charge Voltage	436.8V DC	4.2V/cell
	Standard Charge Current	22.3A	1/3C
	Maximum Peak Charge Current	250A	2 second pulse
	Maximum Continuous Charging Current	67A	1C
6	Recommended Operation Temperature	23±5°C	
7	Storage Temperature	0 ~ 40°C	
8	Storage Humidity	Less than 90 % RH	Noncondensing
9	Recommended Storage Humidity	Less than 60 % RH	Noncondensing
10	Storage Period <sup>2</sup>	Less than 6 months	

<sup>1</sup> Specified voltage must be satisfied in all load and charging conditions.

<sup>2</sup> Capacity degradation will occur depending on storage time. To minimize capacity degradation, storage temperature of less than 10°C and 3.630V per cell is recommended.

Table 3-14: Range of Operation (80S Configuration)

No.	Item	Specification	Remarks
1	Nominal Capacity	20.4kWh	1/3C@R.T
2	Nominal Voltage <sup>1</sup>	304V DC	3.8V/cell
3	Maximum Voltage <sup>1</sup>	336V DC	4.2V/cell
4	Discharging Method	Constant Power	
	End of Discharge Voltage <sup>1</sup>	240V DC	3.0V/cell
	Recommended End of Discharge Voltage	256V DC	3.2V/cell
	Standard Discharging Current	22.3A	1/3C@R.T
	Maximum Continuous Discharge Power	108kW	Peak 450A @ EODV
5	Charging Method	CC-CV, Floating	
	Floating Charge Voltage	336V DC	4.2V/cell
	Standard Charge Current	22.3A	1/3C
	Maximum Peak Charge Current	250A	2 second pulse
	Maximum Continuous Charging Current	67A	1C
6	Recommended Operation Temperature	23±5°C	
7	Storage Temperature	0 ~ 40°C	
8	Storage Humidity	Less than 90 % RH	Noncondensing
9	Recommended Storage Humidity	Less than 60 % RH	Noncondensing
10	Storage Period <sup>2</sup>	Less than 6 months	

<sup>1</sup> Specified voltage must be satisfied in all load and charging conditions.

<sup>2</sup> Capacity degradation will occur depending on storage time. To minimize capacity degradation, storage temperature of less than 10°C and 3.630V per cell is recommended.

When the operating limits of the battery system are exceeded, protective measures are taken autonomously to protect the system from failure. The following table lists the protective functions and their actions.

Table 3-15. Protective Functions (136S Configuration)

No	Items	Level	SET Condition	Time (Sec)	MCCB	Release Condition	Time (Sec)	MCCB
1	Over Voltage Protection - Cell	Major	Max Cell $\geq 4.28V$	5	OFF	Max Cell $< 4.25V$ & Reset	5	ON
2	Under Voltage Protection - Cell	Major	Min Cell $\leq 2.5V$	3	OFF	Min Cell $> 2.70V$ & Reset	3	ON
3	Over Voltage Protection - Rack	Major	Rack Voltage $\geq 582.08V$	5	OFF	Rack Voltage $< 578V$ & Reset	5	ON
4	Under Voltage Protection - Rack	Major	Rack Voltage $\leq 340$	3	OFF	Rack Voltage $> 367.2V$ & Reset	3	ON
5	Voltage Imbalance	Major	Max Cell $\geq 3.80V$ & $\Delta V_{cell} \geq 100mV$	5	OFF	$\Delta V_{cell} < 30mV$ & Reset	5	ON
6	Voltage Sensing Error (Rack)	Minor	$  \text{Rack V} - \text{Cell Sum V}   \geq 40.8V$	10	ON	$  \text{Rack V} - \text{Cell Sum V}   < 20.4V$ & Reset	3	ON
7	Voltage Sensing Error (Module)	Minor	$  \text{Module V} - \text{Cell Sum V}   \geq 190mV$	5	ON	$  \text{Module V} - \text{Cell Sum V}   < 190mV$ & Reset	3	ON
8	Over Temperature Protection	Major	Max Temp $\geq 75^{\circ}C$	3	OFF	Max Temp $< 65^{\circ}C$ & Reset	3	ON
9	Under Temperature Protection	Minor	Min Temp $\leq 0^{\circ}C$	3	ON	Min Temp $> 5^{\circ}C$ & Reset	3	ON
10	Temperature imbalance	Major	Max Cell T - Min Cell T $\geq 40^{\circ}C$	30	OFF	Max Cell T - Min Cell T $< 20^{\circ}C$ & Reset	3	ON
11	Over Current Protection (Charge)	Major	Level2 Current $\geq 250A$	2	OFF	$  \text{Current}   < 10A$ & Reset	3	ON
		Major	Level1 Current $\geq 200A$	60	OFF	$  \text{Current}   < 10A$ & Reset	3	ON
12	Over Current Protection (Discharge)	Major	Level4 $  \text{Current}   \geq 600A$	1	OFF	$  \text{Current}   < 10A$ & Reset	3	ON
		Major	Level3 $  \text{Current}   \geq 540A$	10	OFF	$  \text{Current}   < 10A$ & Reset	3	ON
		Major	Level2 $  \text{Current}   \geq 495A$	30	OFF	$  \text{Current}   < 10A$ & Reset	3	ON
		Major	Level1 $  \text{Current}   \geq 470A$	60	OFF	$  \text{Current}   < 10A$ & Reset	3	ON
13	Communication Failure (Module $\leftrightarrow$ Rack)	Major	No Communication	30	OFF	Re Communication & Reset	-	ON
14	Communication Failure (Rack $\leftrightarrow$ System)	Major	No Communication	30	OFF	Re Communication & Reset	-	ON
15	SW Failure - MCCB	Minor	MCCB OFF & $  \text{Current}   \geq 2.4A$	3	ON	(MCCB OFF & $(  \text{Current}   < 2.4A)$ & Reset	-	ON
16	SW Sensor Failure - MCCB	Minor	MCCB contact ON = MCCB Trip ON	3	ON	(MCCB contact $\neq$ MCCB Trip) & Reset	-	ON
17	Current Sensing Error	Minor	No communication with Current IC	3	ON	Re communication with Current IC	-	ON
18	Fuse Failure	Minor	Fuse Blown	10	ON	Fuse ON & Reset	-	ON

Table 3-16. Protective Functions (128S Configuration)

No	Items	Level	SET Condition	Time (Sec)	MCCB	Release Condition	Time (Sec)	MCCB
1	Over Voltage Protection - Cell	Major	Max Cell $\geq 4.28V$	5	OFF	Max Cell $< 4.25V$ & Reset	5	ON
2	Under Voltage Protection - Cell	Major	Min Cell $\leq 2.5V$	3	OFF	Min Cell $> 2.70V$ & Reset	3	ON
3	Over Voltage Protection - Rack	Major	Rack Voltage $\geq 547.84V$	5	OFF	Rack Voltage $< 544V$ & Reset	5	ON
4	Under Voltage Protection - Rack	Major	Rack Voltage $\leq 320$	3	OFF	Rack Voltage $> 345.6V$ & Reset	3	ON
5	Voltage Imbalance	Major	Max Cell $\geq 3.80V$ & $\Delta V_{cell} \geq 100mV$	5	OFF	$\Delta V_{cell} < 30mV$ & Reset	5	ON
6	Voltage Sensing Error (Rack)	Minor	$ Rack V - Cell Sum V  \geq 38.4V$	10	ON	$ Rack V - Cell Sum V  < 19.2V$ & Reset	3	ON
7	Voltage Sensing Error (Module)	Minor	$ Module V - Cell Sum V  \geq 190mV$	5	ON	$ Module V - Cell Sum V  < 190mV$ & Reset	3	ON
8	Over Temperature Protection	Major	Max Temp $\geq 75^{\circ}C$	3	OFF	Max Temp $< 65^{\circ}C$ & Reset	3	ON
9	Under Temperature Protection	Minor	Min Temp $\leq 0^{\circ}C$	3	ON	Min Temp $> 5^{\circ}C$ & Reset	3	ON
10	Temperature imbalance	Major	Max Cell T - Min Cell T $\geq 40^{\circ}C$	30	OFF	Max Cell T - Min Cell T $< 20^{\circ}C$ & Reset	3	ON
11	Over Current Protection (Charge)	Major	Level2 Current $\geq 250A$	2	OFF	$ Current  < 10A$ & Reset	3	ON
		Major	Level1 Current $\geq 200A$	60	OFF	$ Current  < 10A$ & Reset	3	ON
12	Over Current Protection (Discharge)	Major	Level4 $ Current  \geq 600A$	1	OFF	$ Current  < 10A$ & Reset	3	ON
		Major	Level3 $ Current  \geq 540A$	10	OFF	$ Current  < 10A$ & Reset	3	ON
		Major	Level2 $ Current  \geq 495A$	30	OFF	$ Current  < 10A$ & Reset	3	ON
		Major	Level1 $ Current  \geq 470A$	60	OFF	$ Current  < 10A$ & Reset	3	ON
13	Communication Failure (Module $\leftrightarrow$ Rack)	Major	No Communication	30	OFF	Re Communication & Reset	-	ON
14	Communication Failure (Rack $\leftrightarrow$ System)	Major	No Communication	30	OFF	Re Communication & Reset	-	ON
15	SW Failure - MCCB	Minor	MCCB OFF & $ Current  \geq 2.4A$	3	ON	(MCCB OFF & $( Current  < 2.4A)$ & Reset	-	ON
16	SW Sensor Failure - MCCB	Minor	MCCB contact ON = MCCB Trip ON	3	ON	(MCCB contact $\neq$ MCCB Trip) & Reset	-	ON
17	Current Sensing Error	Minor	No communication with Current IC	3	ON	Re communication with Current IC	-	ON
18	Fuse Failure	Minor	Fuse Blown	10	ON	Fuse ON & Reset	-	ON

Table 3-17. Protective Functions (112S Configuration)

No	Items	Level	SET Condition	Time (Sec)	MCCB	Release Condition	Time (Sec)	MCCB
1	Over Voltage Protection - Cell	Major	Max Cell $\geq 4.28V$	5	OFF	Max Cell $< 4.25V$ & Reset	5	ON
2	Under Voltage Protection - Cell	Major	Min Cell $\leq 2.5V$	3	OFF	Min Cell $> 2.70V$ & Reset	3	ON
3	Over Voltage Protection - Rack	Major	Rack Voltage $\geq 479.36V$	5	OFF	Rack Voltage $< 476V$ & Reset	5	ON
4	Under Voltage Protection - Rack	Major	Rack Voltage $\leq 280$	3	OFF	Rack Voltage $> 302.4V$ & Reset	3	ON
5	Voltage Imbalance	Major	Max Cell $\geq 3.80V$ & $\Delta V_{cell} \geq 100mV$	5	OFF	$\Delta V_{cell} < 30mV$ & Reset	5	ON
6	Voltage Sensing Error (Rack)	Minor	$  \text{Rack V} - \text{Cell Sum V}   \geq 33.6V$	10	ON	$  \text{Rack V} - \text{Cell Sum V}   < 16.8V$ & Reset	3	ON
7	Voltage Sensing Error (Module)	Minor	$  \text{Module V} - \text{Cell Sum V}   \geq 190mV$	5	ON	$  \text{Module V} - \text{Cell Sum V}   < 190mV$ & Reset	3	ON
8	Over Temperature Protection	Major	Max Temp $\geq 75^{\circ}C$	3	OFF	Max Temp $< 65^{\circ}C$ & Reset	3	ON
9	Under Temperature Protection	Minor	Min Temp $\leq 0^{\circ}C$	3	ON	Min Temp $> 5^{\circ}C$ & Reset	3	ON
10	Temperature imbalance	Major	Max Cell T - Min Cell T $\geq 40^{\circ}C$	30	OFF	Max Cell T - Min Cell T $< 20^{\circ}C$ & Reset	3	ON
11	Over Current Protection (Charge)	Major	Level2 Current $\geq 250A$	2	OFF	$  \text{Current}   < 10A$ & Reset	3	ON
		Major	Level1 Current $\geq 200A$	60	OFF	$  \text{Current}   < 10A$ & Reset	3	ON
12	Over Current Protection (Discharge)	Major	Level4 $  \text{Current}   \geq 600A$	1	OFF	$  \text{Current}   < 10A$ & Reset	3	ON
		Major	Level3 $  \text{Current}   \geq 540A$	10	OFF	$  \text{Current}   < 10A$ & Reset	3	ON
		Major	Level2 $  \text{Current}   \geq 495A$	30	OFF	$  \text{Current}   < 10A$ & Reset	3	ON
		Major	Level1 $  \text{Current}   \geq 470A$	60	OFF	$  \text{Current}   < 10A$ & Reset	3	ON
13	Communication Failure (Module $\leftrightarrow$ Rack)	Major	No Communication	30	OFF	Re Communication & Reset	-	ON
14	Communication Failure (Rack $\leftrightarrow$ System)	Major	No Communication	30	OFF	Re Communication & Reset	-	ON
15	SW Failure - MCCB	Minor	MCCB OFF & $  \text{Current}   \geq 2.4A$	3	ON	(MCCB OFF & $(  \text{Current}   < 2.4A)$ & Reset	-	ON
16	SW Sensor Failure - MCCB	Minor	MCCB contact ON = MCCB Trip ON	3	ON	(MCCB contact $\neq$ MCCB Trip) & Reset	-	ON
17	Current Sensing Error	Minor	No communication with Current IC	3	ON	Re communication with Current IC	-	ON
18	Fuse Failure	Minor	Fuse Blown	10	ON	Fuse ON & Reset	-	ON

Table 3-18. Protective Functions (104S Configuration)

No	Items	Level	SET Condition	Time (Sec)	MCCB	Release Condition	Time (Sec)	MCCB
1	Over Voltage Protection - Cell	Major	Max Cell $\geq 4.28V$	5	OFF	Max Cell $< 4.25V$ & Reset	5	ON
2	Under Voltage Protection - Cell	Major	Min Cell $\leq 2.5V$	3	OFF	Min Cell $> 2.70V$ & Reset	3	ON
3	Over Voltage Protection - Rack	Major	Rack Voltage $\geq 445.12V$	5	OFF	Rack Voltage $< 442V$ & Reset	5	ON
4	Under Voltage Protection - Rack	Major	Rack Voltage $\leq 260$	3	OFF	Rack Voltage $> 280.8V$ & Reset	3	ON
5	Voltage Imbalance	Major	Max Cell $\geq 3.80V$ & $\Delta V_{cell} \geq 100mV$	5	OFF	$\Delta V_{cell} < 30mV$ & Reset	5	ON
6	Voltage Sensing Error (Rack)	Minor	$ Rack V - Cell Sum V  \geq 31.2V$	10	ON	$ Rack V - Cell Sum V  < 15.6V$ & Reset	3	ON
7	Voltage Sensing Error (Module)	Minor	$ Module V - Cell Sum V  \geq 190mV$	5	ON	$ Module V - Cell Sum V  < 190mV$ & Reset	3	ON
8	Over Temperature Protection	Major	Max Temp $\geq 75^{\circ}C$	3	OFF	Max Temp $< 65^{\circ}C$ & Reset	3	ON
9	Under Temperature Protection	Minor	Min Temp $\leq 0^{\circ}C$	3	ON	Min Temp $> 5^{\circ}C$ & Reset	3	ON
10	Temperature imbalance	Major	Max Cell T - Min Cell T $\geq 40^{\circ}C$	30	OFF	Max Cell T - Min Cell T $< 20^{\circ}C$ & Reset	3	ON
11	Over Current Protection (Charge)	Major	Level2 Current $\geq 250A$	2	OFF	$ Current  < 10A$ & Reset	3	ON
		Major	Level1 Current $\geq 200A$	60	OFF	$ Current  < 10A$ & Reset	3	ON
12	Over Current Protection (Discharge)	Major	Level4 $ Current  \geq 600A$	1	OFF	$ Current  < 10A$ & Reset	3	ON
		Major	Level3 $ Current  \geq 540A$	10	OFF	$ Current  < 10A$ & Reset	3	ON
		Major	Level2 $ Current  \geq 495A$	30	OFF	$ Current  < 10A$ & Reset	3	ON
		Major	Level1 $ Current  \geq 470A$	60	OFF	$ Current  < 10A$ & Reset	3	ON
13	Communication Failure (Module $\leftrightarrow$ Rack)	Major	No Communication	30	OFF	Re Communication & Reset	-	ON
14	Communication Failure (Rack $\leftrightarrow$ System)	Major	No Communication	30	OFF	Re Communication & Reset	-	ON
15	SW Failure - MCCB	Minor	MCCB OFF & $ Current  \geq 2.4A$	3	ON	(MCCB OFF & $( Current  < 2.4A)$ & Reset	-	ON
16	SW Sensor Failure - MCCB	Minor	MCCB contact ON = MCCB Trip ON	3	ON	(MCCB contact $\neq$ MCCB Trip) & Reset	-	ON
17	Current Sensing Error	Minor	No communication with Current IC	3	ON	Re communication with Current IC	-	ON
18	Fuse Failure	Minor	Fuse Blown	10	ON	Fuse ON & Reset	-	ON

Table 3-19. Protective Functions (80S Configuration)

No	Items	Level	SET Condition	Time (Sec)	MCCB	Release Condition	Time (Sec)	MCCB
1	Over Voltage Protection - Cell	Major	Max Cell $\geq 4.28V$	5	OFF	Max Cell $< 4.25V$ & Reset	5	ON
2	Under Voltage Protection - Cell	Major	Min Cell $\leq 2.5V$	3	OFF	Min Cell $> 2.70V$ & Reset	3	ON
3	Over Voltage Protection - Rack	Major	Rack Voltage $\geq 342.4V$	5	OFF	Rack Voltage $< 340V$ & Reset	5	ON
4	Under Voltage Protection - Rack	Major	Rack Voltage $\leq 200$	3	OFF	Rack Voltage $> 216V$ & Reset	3	ON
5	Voltage Imbalance	Major	Max Cell $\geq 3.80V$ & $\Delta V_{cell} \geq 100mV$	5	OFF	$\Delta V_{cell} < 30mV$ & Reset	5	ON
6	Voltage Sensing Error (Rack)	Minor	$ Rack V - Cell Sum V  \geq 24V$	10	ON	$ Rack V - Cell Sum V  < 12V$ & Reset	3	ON
7	Voltage Sensing Error (Module)	Minor	$ Module V - Cell Sum V  \geq 190mV$	5	ON	$ Module V - Cell Sum V  < 190mV$ & Reset	3	ON
8	Over Temperature Protection	Major	Max Temp $\geq 75^{\circ}C$	3	OFF	Max Temp $< 65^{\circ}C$ & Reset	3	ON
9	Under Temperature Protection	Minor	Min Temp $\leq 0^{\circ}C$	3	ON	Min Temp $> 5^{\circ}C$ & Reset	3	ON
10	Temperature imbalance	Major	Max Cell T - Min Cell T $\geq 40^{\circ}C$	30	OFF	Max Cell T - Min Cell T $< 20^{\circ}C$ & Reset	3	ON
11	Over Current Protection (Charge)	Major	Level2 Current $\geq 250A$	2	OFF	$ Current  < 10A$ & Reset	3	ON
		Major	Level1 Current $\geq 200A$	60	OFF	$ Current  < 10A$ & Reset	3	ON
12	Over Current Protection (Discharge)	Major	Level4 $ Current  \geq 600A$	1	OFF	$ Current  < 10A$ & Reset	3	ON
		Major	Level3 $ Current  \geq 540A$	10	OFF	$ Current  < 10A$ & Reset	3	ON
		Major	Level2 $ Current  \geq 495A$	30	OFF	$ Current  < 10A$ & Reset	3	ON
		Major	Level1 $ Current  \geq 470A$	60	OFF	$ Current  < 10A$ & Reset	3	ON
13	Communication Failure (Module $\leftrightarrow$ Rack)	Major	No Communication	30	OFF	Re Communication & Reset	-	ON
14	Communication Failure (Rack $\leftrightarrow$ System)	Major	No Communication	30	OFF	Re Communication & Reset	-	ON
15	SW Failure - MCCB	Minor	MCCB OFF & $ Current  \geq 2.4A$	3	ON	(MCCB OFF & ( $ Current  < 2.4A$ ) & Reset	-	ON
16	SW Sensor Failure - MCCB	Minor	MCCB contact ON = MCCB Trip ON	3	ON	(MCCB contact $\neq$ MCCB Trip) & Reset	-	ON
17	Current Sensing Error	Minor	No communication with Current IC	3	ON	Re communication with Current IC	-	ON
18	Fuse Failure	Minor	Fuse Blown	10	ON	Fuse ON & Reset	-	ON

### 3.3.1 Normal Status

In normal status, the battery system is available for charge or discharge. The system operator must follow the guidelines below to ensure safe and optimal performance from the battery.

- The battery must be fully charged to power the critical load for the duration of the backup time.
- After a full discharge at maximum continuous power, cool the battery for at least 12 hours before another discharge in order to avoid over-temperature protection. For optimal performance, wait until the battery temperature returns to at least  $\pm 3^{\circ}\text{C}$  within the room temperature.
- Immediate recharging after a full discharge at maximum continuous power may degrade the battery performance.

### 3.3.2 Minor Protection Status (Alarm)

When a minor protection (alarm status) occurs, the battery system will send a message to the UPS or other systems and request that all charge or discharge operation be stopped until the problem is corrected. Battery system will not be disconnected in minor protection status to maximize the battery's availability. Refer to Section 5 "Troubleshooting" for solutions to minor protection status.

### 3.3.3 Major Protection Status (Fault)

If the system detects a major protection (fault status), it will trip the MCCB to disconnect the battery system from the UPS to prevent damage to the battery. Measures must be taken to clear the major protection status and return the battery system to normal status. Personnel must be on-site to return the MCCB from "trip" to "on" position after returning the system status to normal. Refer to Section 5 "Troubleshooting" for details on solutions to major protection status.



## 4. Maintenance Checks

The battery system components are designed to be free of regular maintenance. Regular inspection of components and power connections are recommended to ensure proper performance. Scheduled checks of the battery system are recommended but not mandatory for optimal performance. Refer to 3.3 Operation Status for the battery system's operating conditions.

### 4.1 Daily Checks

Following is a list of items to be checked daily.

- Rack voltage should be in its floating charge voltage.
- Cell voltage range should be within 300mV.
- MCCB must be on for all racks.
- There must be no alarms or faults.
- Maintaining room temperature and humidity according to the range of operation..

### 4.2 Monthly Checks

Personnel should visually inspect the battery system monthly and review log data about the battery and its operating environment.

- Battery should have no visible damage (rust, bent structure, damaged or missing cables or busbars, etc.)
- Check the recorded data of the battery system for the voltage and current readings.
- Check the date and time of charge and discharge cycles.
- Check whether any alarms or faults have been triggered.

### 4.3 Annual Check

A trend analysis of the recorded data (battery and environment) is recommended.

## 4.4 Maintenance Checklist

Refer to the following checklist template for scheduled checks. Detailed recordings may be necessary depending on the level of maintenance required by the user. Use Table 3-10: Range of Operation to check the criteria for each item.

Table 4-1: Maintenance Checklist Template

Items	Criteria	Location	Schedule	Result
Battery Status	1. Battery voltage a) Rack voltage check b) Cell voltage check (max/min difference) 2. Alarm or faults: No alarms or faults set 3. MCCB status: All on	Control room	Daily	
	1. Alarm or protection: No alarms or protections set Check the indicator LED's in each rack 2. MCCB status: All on Check the position of the MCCB handle	On-Site	Weekly	
	1. Visual Inspection: check for physical damages (rust, bent structure, damaged or missing cables, etc.)	On-Site	Monthly	
Environment	Temperature (measured from facility's HVAC unit or other measurement devices)	Control Room or On-Site	Daily	
	Humidity (measured from facility's HVAC unit or other measurement device)		Daily	
Recorded Data	1. Recorded voltage and current 2. Date and time of charge and discharge cycles 3. Number of alarms and faults recorded	Control Room	Monthly	
	1. Recorded voltage and current 2. Date and time of charge and discharge cycles 3. Number of alarms and faults recorded 4. Record of temperature and humidity (measured from facility's HVAC unit or other measurement device)	Control Room	Annual	

## 5. Troubleshooting, Repair and Replacement





Users must operate the battery system within its specified range of operating conditions. Refer to the “Product Specification” for details.





If the battery system is not operated under the specified conditions, it may display protective modes depending on conditions. Users should familiarize themselves with the types of protective modes and the battery system’s behavior during these modes. Dry contact signals from the System BMS and indicator LED’s on the front of each SMU displays the status of the battery system. Users can quickly and easily determine the battery system’s status from a centralized monitoring location using the dry contact signals or perform an on-site examination using the indicator LED’s. Detailed status of the battery system can be examined by using additional monitoring software.

When additional examination is necessary, some tools and instruments may be required. Refer to the installation manual and Table 5-1 “Recommended Tools and Instruments for Repair and Replacement” for the list of tools that may be needed and instructions on how to use them.

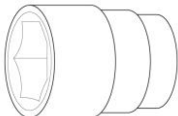
If repair or replacement is required, refer to the installation manual for safety guidelines and basic information on disassembly and reassembly of components.

Table 5-1: Recommended Tools and Instruments for Repair and Replacement

No.	Items	Use	Appearance
1	Power Screwdriver/Drill (Maximum torque: 26Nm [270 kgf cm])	Fastening SMU and SMPS assemblies to the rack frames (5.1–6.1Nm [50–60 kgf cm])	
2	Phillips Screwdriver or Bit (M5 Tip)	Fastening SMU and SMPS assemblies to the rack frames	
3	Box Cutter	Opening boxes	
4	Forklift	Moving pallets of modules and SMUs	
5	Insulated Torque Wrench	Installing high-voltage cable (10~50 Nm [100 ~ 500 kgf cm])	
6	Insulated Sockets (13 mm, 17mm and 19mm)	Installing power cables and busbars	

No.	Items	Use	Appearance
7	Insulated Extension Bar for Sockets	Installing a power cable	
8	Battery Tester	Measuring battery modules' voltage and internal impedance	
9	Digital Multimeter	Measuring battery string's voltage Probes must be rated for 600V DC or above	
10	DC Ammeter (Clamp Meter)	Measuring battery string's current Must be rated for DC 1000A or above	-
11	Controllable DC Load Recommended Specifications 1) Input DC 40V or above 2) 1kW or above 3) Controllable with 10mV resolution or less 4) CV discharge available	Discharging replacement battery module	-
12	Controllable DC Power Supply Recommended specifications 1) Output DC 40V or above 2) 1kW or above 3) Controllable with 10mV resolution or less 4) CC-CV charge available	Charging replacement battery module	-
13	Computer Microsoft® Windows® 7 SP1 (English) or later recommended	Running battery monitoring software	

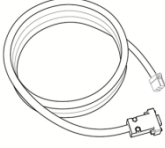
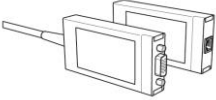
No.	Items	Use	Appearance
14	Rack BMS ID Writer Cable Use with computer	Battery monitoring software	
15	IXXAT USB-to-CAN V2 Use with computer	Battery monitoring software	

## 5.1 Troubleshooting

To determine the status of the battery system, users must use additional battery status monitoring software to examine the protection mode. Refer to the installation manual about using the monitoring software. Also, refer to Section 3.3 Operation Status for set and release conditions for each protection mode. Once the user knows the protection mode, refer to the following sections for solutions.

### 5.1.1 Overvoltage Protection – Cell (Major Protection)

Possible Problem	Solution
Overcharged Cell	<ul style="list-style-type: none"> <li>- Press the reset switch in SMPS Assembly and see if it clears the protection.</li> <li>- Check the UPS settings for floating charge voltage. It must be set at 4.2V per cell (i.e., for 136S system, 571.2V must be set as floating charge voltage and for 128S system, 537.6V must be set as floating charge voltage)</li> <li>- Check the dry contact signal cable for “charge stop” and see whether the “charge stop” signal is correctly received by the UPS.</li> <li>- Check the actual cell voltage data using monitoring software and see if there is a cell voltage reading significantly higher than other battery cells. If so, cell balancing is required. Refer to troubleshooting for voltage imbalance.</li> <li>- If the problem persists, the module with the overcharged cell may have to be replaced.</li> </ul>
Defective Wiring	<ul style="list-style-type: none"> <li>- Remove the front cover of the module and check the Module BMS wiring.</li> <li>- Press the reset switch in SMPS Assembly and see if it clears the protection.</li> </ul>
Loose Busbar Installation	<ul style="list-style-type: none"> <li>- Check the torque of the module and SMU busbars.</li> <li>- Retighten any loose bolts.</li> </ul>
Measurement Error	<ul style="list-style-type: none"> <li>- Press the reset switch in SMPS Assembly and see if it clears the protection.</li> <li>- Check the actual cell voltage data using monitoring software.</li> <li>- Replace the Module BMS if the cell voltage is incorrect.</li> <li>- If the problem persists, replace the battery module.</li> </ul>

### 5.1.2 Undervoltage Protection – Cell (Major Protection)

Possible Problem	Solution
Deep-Discharged Cell	<ul style="list-style-type: none"> <li>- Press the reset switch in the SMPS Assembly and see if it clears the protection.</li> <li>- Check the UPS settings for the end-of-discharge voltage. It must be set at 3.0V per cell (i.e., for 136S system, 408V must be set as the end-of-discharge voltage and for 128S system, 384V must be set as end of discharge voltage).</li> <li>- Check the actual cell voltage data using monitoring software and see if there is a cell voltage reading significantly lower than for other battery cells. If so, cell balancing is required. Refer to the Troubleshooting Section 5.2.5 “Cell Voltage Balancing.”</li> </ul>
Defective Wiring	<ul style="list-style-type: none"> <li>- Remove the Battery Module’s front and check the Module BMS wiring.</li> <li>- Press the reset switch in the SMPS Assembly and see if it clears the protection.</li> </ul>
Loose Busbar	<ul style="list-style-type: none"> <li>- Check the torque of the module and SMU busbars.</li> <li>- Retighten any loose bolts.</li> </ul>
Measurement Error	<ul style="list-style-type: none"> <li>- Press the reset switch in SMPS Assembly and see if it clears the protection.</li> <li>- Check the actual cell voltage data using monitoring software.</li> <li>- Replace the Module BMS if the cell voltage is incorrect.</li> <li>- If the problem persists, replace the battery module.</li> </ul>

**5.1.3 Overvoltage Protection – Rack (Major Protection)**

Possible Problem	Solution
Overcharged Cell	<ul style="list-style-type: none"> <li>- Check the UPS settings for floating charge voltage. It must be set at 4.2V per cell (i.e., for 136S system, 571.2V must be set as floating charge voltage and for 128S system, 537.6V must be set as floating charge voltage).</li> <li>- Check the dry contact signal cable for “charge stop” and see if the “charge stop” signal is correctly received by the UPS.</li> <li>- Check the actual cell voltage data using monitoring software and see if there is a cell voltage reading significantly higher than for other battery cells. If so, cell balancing is required. Refer to Troubleshooting Section 5.2.5 “Cell Voltage Balancing.”</li> <li>- If the problem repeats, the Battery Module with the overcharged cell may have to be replaced.</li> </ul>
Loose Busbar	<ul style="list-style-type: none"> <li>- Check the torque of the module and SMU busbars.</li> <li>- Retighten any loose bolts.</li> </ul>
Measurement Error	<ul style="list-style-type: none"> <li>- Check the actual rack voltage data using monitoring software.</li> <li>- Replace the SMU if the rack voltage readings are incorrect.</li> </ul>

**5.1.4 Undervoltage Protection – Rack (Major Protection)**

Possible Problem	Solution
Deep-Discharged Cell	<ul style="list-style-type: none"> <li>- Check the UPS settings for end of discharge voltage. It must be set at 3.0V per cell. (i.e., for 136S system, 408V must be set as end-of-discharge voltage. and for 128S system, 384V must be set as the end-of-discharge voltage).</li> <li>- Check the actual cell voltage data using monitoring software and see if there is a cell voltage reading significantly lower than for other battery cells. If so, cell balancing is required. Refer to Troubleshooting Section 5.2.5 “Cell Voltage Balancing.”</li> </ul>
Loose Busbar	<ul style="list-style-type: none"> <li>- Check the torque of the module and SMU busbars.</li> <li>- Retighten any loose bolts.</li> </ul>
Blown Fuse	<ul style="list-style-type: none"> <li>- Check whether the “fuse failure” alarm is set.</li> <li>- Check the status of the rack fuse.</li> <li>- Replace any blown fuse and reset the system.</li> </ul>
Measurement Error	<ul style="list-style-type: none"> <li>- Check the actual rack voltage data using monitoring software</li> <li>- Replace the SMU if the rack voltage is incorrect.</li> </ul>

**5.1.5 Voltage Imbalance (Major Protection)**

Possible Problem	Solution
Imbalanced Cell	<ul style="list-style-type: none"> <li>- Check the actual cell voltage data using monitoring software and see if there is a cell voltage reading significantly higher or lower than for other battery cells. If so, cell balancing is required. Refer to Troubleshooting Section 5.2.5 “Cell Voltage Balancing.”</li> </ul>
Loose Busbar	<ul style="list-style-type: none"> <li>- Check the torque of the module and SMU busbars.</li> <li>- Retighten any loose bolts.</li> </ul>
Defective Wiring	<ul style="list-style-type: none"> <li>- Remove the front cover of the module and check the Module BMS wiring.</li> <li>- Press the reset switch in the SMPS Assembly and see if it clears the protection.</li> </ul>
Measurement Error	<ul style="list-style-type: none"> <li>- Check the actual cell voltage data using monitoring software</li> <li>- Replace the Module BMS if the cell voltage is incorrect.</li> <li>- If the problem persists, replace the battery module.</li> </ul>

### 5.1.6 Voltage Sensing Error (Minor Protection)

Possible Problem	Solution
Defective Wiring	<ul style="list-style-type: none"> <li>- Remove the module's front cover and check the Module BMS wiring.</li> <li>- Press the reset switch in the SMPS Assembly and see if it clears the protection.</li> </ul>
Loose busbar	<ul style="list-style-type: none"> <li>- Check the torque of the module and SMU busbars.</li> <li>- Retighten any loose bolts.</li> </ul>
Measurement Error	<ul style="list-style-type: none"> <li>- Check the actual cell voltage data using monitoring software.</li> <li>- Check the actual rack voltage data using monitoring software.</li> <li>- Measure the rack voltage and each module's voltage using a digital multimeter and compare the readings to the data obtained from the monitoring software. To measure the rack's voltage, a multimeter with proper probe rating must be used.</li> <li>- If module voltage reading is not correct, determine which module has the incorrect voltage and check its Module BMS connection. If the problem persists, replace the module BMS.</li> <li>- If the problem persists, the module must be replaced.</li> <li>- Replace the SMU if the rack voltage is incorrect.</li> </ul>

### 5.1.7 Overtemperature Protection (Major Protection)

Possible Problem	Solution
Defective Wiring	<ul style="list-style-type: none"> <li>- Remove the module's front cover and check the Module BMS wiring.</li> <li>- Press the reset switch in the SMPS Assembly and see if it clears the protection.</li> </ul>
Measurement Error	<ul style="list-style-type: none"> <li>- Check the actual cell temperature data using monitoring software.</li> <li>- If cell temperature reading is not correct, check the connection of Module BMS.</li> <li>- If the problem persists, the module must be replaced.</li> </ul>
Defective Thermistor	<ul style="list-style-type: none"> <li>- If the thermistor inside the Battery Module is defective (short), the temperature may be fixed at 95°C. Battery Module must be replaced.</li> </ul>
Improper Ventilation	<ul style="list-style-type: none"> <li>- Make sure the rack frame is placed so that air can flow naturally through the frame.</li> <li>- Forced air convection may be used.</li> </ul>

### 5.1.8 Undertemperature Protection (Minor Protection)

Possible Problem	Solution
Defective Wiring	<ul style="list-style-type: none"> <li>- Remove the module's front cover and check the Module BMS wiring.</li> <li>- Press the reset switch in SMPS Assembly and see if it clears the protection.</li> </ul>
Measurement Error	<ul style="list-style-type: none"> <li>- Check the actual cell temperature data using monitoring software.</li> <li>- If cell temperature reading is not correct, check the connection of the Module BMS.</li> <li>- If the problem persists, the Module must be replaced.</li> </ul>
Defective Thermistor	<ul style="list-style-type: none"> <li>- If the thermistor inside the Battery Module is defective (open), the temperature may be set at -30°C. Battery Module must be replaced.</li> </ul>

### 5.1.9 Temperature Imbalance (Major Protection)

Possible Problem	Solution
Defective Wiring	<ul style="list-style-type: none"> <li>- Remove the module's front cover and check the Module BMS wiring.</li> <li>- Press the reset switch in the SMPS Assembly and see if it clears the protection.</li> </ul>
Measurement Error	<ul style="list-style-type: none"> <li>- Check the actual cell temperature data using monitoring software.</li> <li>- If cell temperature reading is not correct, check the connection of Module BMS.</li> </ul>
Defective Thermistor	<ul style="list-style-type: none"> <li>- If the thermistor inside the Battery Module is defective, the temperature may be set at -30°C if opened or 95°C if shorted. Battery module must be replaced.</li> </ul>



Possible Problem	Solution
Improper Ventilation	<ul style="list-style-type: none"> <li>- Make sure that the rack frame is placed so that air can flow naturally through the frame.</li> <li>- Forced air convection may be used to provide extra cooling.</li> </ul>

**5.1.10 Overcurrent Protection (Charge) (Major Protection)**

Possible Problem	Solution
Adjacent Rack Disconnected (multiple rack configuration only)	<ul style="list-style-type: none"> <li>- Current flow may be concentrated in a multiple rack configuration if only some racks are connected and some are disconnected.</li> <li>- Make sure that the MCCB in all racks are in the “on” position.</li> </ul>
Inrush Current from Adjacent Rack (multiple rack configuration only)	<ul style="list-style-type: none"> <li>- If there is a voltage difference between the racks, there may be inrush current from rack to rack.</li> <li>- Measure the rack’s inrush current in all conditions using a clamp meter.</li> <li>- Match the rack’s voltage by installing modules with similar voltage for different strings.</li> </ul>
Inrush Current from UPS	<ul style="list-style-type: none"> <li>- Use a clamp meter to measure the inrush current when the UPS is initially switched on.</li> <li>- Condition the UPS DC bus to reduce or eliminate the inrush.</li> </ul>
Measurement Error	<ul style="list-style-type: none"> <li>- Check the current readings using the monitoring program.</li> <li>- If the values are sporadic, the BMS may be malfunctioning.</li> <li>- If the values are constant but incorrect, the BMS may be calibrated incorrectly.</li> <li>- Replace the SMU.</li> </ul>

**5.1.11 Overcurrent Protection (Discharge) (Major Protection)**

Possible Problem	Solution
Adjacent Rack Disconnected (multiple rack configuration only)	<ul style="list-style-type: none"> <li>- Current flow may be concentrated in a multiple rack configuration if some racks are connected and some are disconnected.</li> <li>- Make sure that the MCCB in all racks are in the “on” position.</li> </ul>
Inrush Current from Adjacent Rack (multiple rack configuration only)	<ul style="list-style-type: none"> <li>- If there is a voltage difference between the racks, there may be inrush current from rack to rack.</li> <li>- Use a clamp meter to measure the rack’s inrush current in all conditions.</li> <li>- Match the rack’s voltage by installing modules with similar voltage for different strings.</li> </ul>
Inrush Current from UPS	<ul style="list-style-type: none"> <li>- Use a clamp meter to measure the inrush current when the UPS is initially switched on.</li> <li>- Condition the UPS DC bus to reduce or eliminate the inrush.</li> </ul>
Measurement Error	<ul style="list-style-type: none"> <li>- Check the current readings using the monitoring program.</li> <li>- If the values are sporadic, BMS may be malfunctioning.</li> <li>- If the values are constant but incorrect, BMS may be calibrated incorrectly.</li> <li>- Replace the SMU.</li> </ul>

**5.1.12 Communication Failure (Module ↔ Rack) (Major Protection)**

Possible Problem	Solution
Defective Signal Cable	<ul style="list-style-type: none"> <li>- Replace the signal cable between the SMU and the module.</li> <li>- Replace the signal cables between the modules.</li> </ul>
Defective Module BMS	<ul style="list-style-type: none"> <li>- Check the LED on the Module BMS.</li> <li>- If it is not blinking, replace the Module BMS.</li> </ul>

**5.1.13 Communication Failure (Rack ↔ System) (Major Protection)**

Possible Problem	Solution
------------------	----------

Possible Problem	Solution
Signal Termination	- Make sure that the communication terminating switch is on for the SMU that is farthest from the SMPS Assembly Type A.
Defective Signal Cable	- Replace the signal cable between the SMU and the SMPS Assembly. - Press the reset switch in the SMPS Assembly.
Adjacent Rack not Powered	- Check the indicator LED of adjacent racks. - If the POWER LED is not on, make sure that the AC input cables to its own SMPS Assembly are connected correctly and securely. - Check the power cables from the "DC OUT" port of the SMPS Assembly to the SMU's "DC IN" port and make sure they are installed correctly.
Incorrect Rack BMS Configuration	- The Rack BMS CAN ID may be set incorrectly. - Refer to the installation manual for BMS configuration and try setting the CAN ID again. - Reset the system by pressing the reset switch in the SMPS Assembly.
Defective Rack BMS	- Check the status of the indicator LED's. - If all four LED's are on or all off, the Rack BMS may be damaged. - Replace the SMU.
Defective System BMS	- Check the communication from the SMPS Assembly data ports (TCP/IP or RS485) using the monitoring software and, if available, using an oscilloscope to check the waveform of the data signals. - Check the status of the LED inside the SMPS Assembly. Refer to Figure 5-1. System BMS LED If there is only steady red LED, reset the System BMS by removing then reapplying the AC power to the SMPS Assembly (power-on reset). At least one or more red LED should be blinking inside the SMPS Assembly after power-on reset. - Replace the SMPS Assembly if there is no blinking red LED even after a power-on reset.

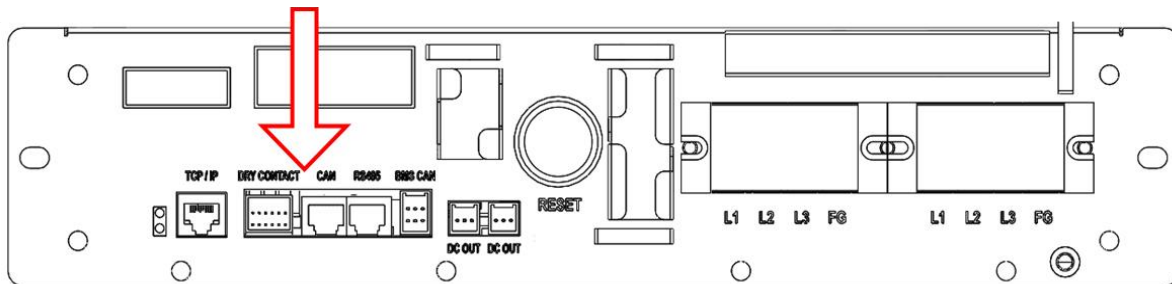

Figure 5-1. System BMS LED

### 5.1.14 Communication Failure (System BMS ↔ Monitoring Software)

Possible Problem	Solution
System BMS improperly initiated	<ul style="list-style-type: none"> <li>- Check the communication from the SMPS Assembly data ports (TCP/IP or RS485) using the monitoring software and, if available, using an oscilloscope to check the waveform of the data signals.</li> <li>- Check the status of the LED inside the SMPS Assembly. Refer to Figure 5-1. System BMS LED</li> <li>If there is only steady red LED or no LED on, reset the System BMS by removing then reapplying the AC power to the SMPS Assembly (power-on reset). At least one or more red LED should be blinking inside the SMPS Assembly after power-on reset.</li> <li>- If the problem persists, refer to 5.1.19. BMS Power is Off.</li> </ul>

### 5.1.15 MCCB Failure (Minor Protection)

Possible Problem	Solution
Defective Rack BMS	<ul style="list-style-type: none"> <li>- Press the reset switch in the SMPS Assembly and see if it clears the protection.</li> <li>- Make sure that the MCCB handle is in the "trip" or "off" position.</li> <li>- Measure the current using monitoring software while the battery is idle.</li> <li>- If measured current is not 0A, the current sensing units may be malfunctioning.</li> <li>- Replace the SMU.</li> </ul>
Defective MCCB	<ul style="list-style-type: none"> <li>- Press the reset switch in the SMPS Assembly and see if it clears the protection.</li> <li>- Make sure that the MCCB handle is in the "trip" or "off" position.</li> <li>- Check the continuity between the "B-" terminal and the "P-" terminal.</li> <li>- If there is continuity between the two terminals, the MCCB is defective.</li> <li>- Replace the SMU.</li> </ul>
Defective Auxiliary Unit	<ul style="list-style-type: none"> <li>- Move the MCCB handle to the "on" position.</li> <li>- Use the monitoring software to check the status of the MCCB.</li> <li>- If the MCCB status is "off," the MCCB auxiliary unit may be malfunctioning.</li> <li>- Replace the SMU.</li> </ul>

### 5.1.16 MCCB Sensor Failure (Minor Protection)

Possible Problem	Solution
Defective Auxiliary Unit	<ul style="list-style-type: none"> <li>- Press the trip button on the MCCB to trip it. Shift the MCCB handle to "off," then to the "on" position.</li> <li>- Press the reset switch in the SMPS Assembly.</li> <li>- If the alarm is not cleared, the rack BMS may be defective.</li> </ul>
Defective Rack BMS	<ul style="list-style-type: none"> <li>- Press the reset switch in the SMPS Assembly and see if it clears the protection.</li> <li>- If the problem persists, replace the SMU.</li> </ul>

### 5.1.17 Current Sensing Error (Minor Protection)

Possible Problem	Solution
Defective Internal Wiring	<ul style="list-style-type: none"> <li>- Press the reset switch in the SMPS Assembly and see if it clears the protection.</li> <li>- Measure the current using monitoring software during charge or discharge.</li> <li>- If there is no reading, there may be a defect in the Rack BMS or the internal wirings in the SMU. Replace the SMU</li> </ul>

**5.1.18 Fuse Failure (Minor Protection)**

Possible Problem	Solution
Fuse Blown	<ul style="list-style-type: none"> <li>- When the MCCB is in the “on” position, check the continuity between the “B-” terminal and “P-” terminal.</li> <li>- If there is no continuity between the two terminals, the fuse is blown and must be replaced. Replace the SMU.</li> </ul>
Defective Fuse Switch	<ul style="list-style-type: none"> <li>- If the fuse is not blown, the switch above the fuse may be malfunctioning.</li> <li>- Replace the SMU.</li> </ul>

**5.1.19 BMS Power is Off**

Possible Problem	Solution
Incorrect Cabling	<ul style="list-style-type: none"> <li>- Check the cable connection to the terminal block on the front side of the SMPS Assembly.</li> <li>- Check the cable connection between the SMPS Assembly “DC OUT” and SMU “DC IN.”</li> </ul>
AC Input Fuse Blown	<ul style="list-style-type: none"> <li>- Remove the SMPS Assembly and remove the top cover.</li> <li>- Check the continuity of the AC input fuse holder.</li> <li>- If any fuse is blown, replace the SMPS Assembly.</li> </ul>
Defective SMPS	<ul style="list-style-type: none"> <li>- If all AC input connections are correctly installed and energized, but the BMS is not being powered, the SMPS Assembly may be defective. Replace the SMPS Assembly.</li> </ul>

**5.1.20 MCCB Handle Cannot be Set to “On”**

Possible Problem	Solution
UPS Signaling the MCCB to Open	<ul style="list-style-type: none"> <li>- Check the status of the UPS. Typical operation and end of discharge or due to an emergency power off will result in a trip signal to the battery MCCB’s. The MCCB’s will be prevented from closing until the UPS signal is removed.</li> </ul>
System in Fault Status	<ul style="list-style-type: none"> <li>- Check the indicator LED on the front side of the SMU</li> <li>- If the FAULT LED (red LED) is blinking, the major protection (fault) status is set.</li> <li>- Major protection must be cleared before setting the MCCB to “on.”</li> <li>- Press the reset button in SMPS Assembly Type A to clear the protection.</li> </ul>
SMPS not Powered	<ul style="list-style-type: none"> <li>- Check the AC input connection.</li> <li>- Check if the AC input is energized.</li> <li>- If all AC input connections are correctly installed and energized, SMPS Assembly may be defective. Replace the SMPS Assembly.</li> </ul>
Defective Cable	<ul style="list-style-type: none"> <li>- Check the cable connection to DC IN</li> <li>- If the cable is defective, replace the DC IN cable</li> </ul>
Defective MCCB Unit	<ul style="list-style-type: none"> <li>- Replace the SMU</li> </ul>
Defective Rack BMS	<ul style="list-style-type: none"> <li>- Check the indicator LED on the front side of the SMU.</li> <li>- If the indicator LED is not operational or if all LED’s are on, the Rack BMS may be defective.</li> <li>- Replace the SMU.</li> </ul>

## 5.2 Repair Procedures

Service personnel can resolve some problems by performing the following procedures without having to call Samsung SDI's customer service.

### 5.2.1 Module BMS Connection Check

CAUTION	
	<ul style="list-style-type: none"><li>▪ Follow the instructions to protect the Module BMS against damage.</li><li>▪ Important: DO NOT deviate from the sequence of steps.</li><li>▪ The voltage of the connected system increases proportionally as battery modules are connected. Exercise extreme caution to prevent the terminals from touching anything other than their intended mounting points.</li><li>▪ Terminals and their connected wires have either positive or negative polarity (Positive: B+, P+; Negative: B-, P-). The polarity of a terminal or a wire connected to the terminal is on the front of each module and SMU. To prevent a potentially dangerous short circuit, use extreme caution to prevent terminals and/or wires with opposite polarity from contacting each other.</li><li>▪ Do not permit either battery terminal to contact the rack frame because it is possible to contact a connection with the opposite polarity.</li></ul>

Check the following points to make sure the Module BMS is connected correctly.

1. Check the wire connection to the signal connectors. Make sure they are firmly inserted into the connector.

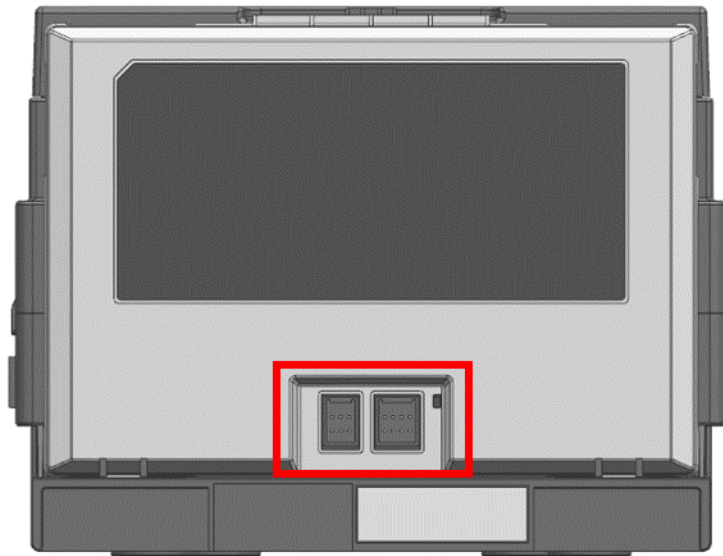

Figure 5-2: Signal Connectors

2. Remove the front cover to check the voltage and temperature sensing connectors. Press the hook on the bus bar openings and pull the front cover towards the front to remove.

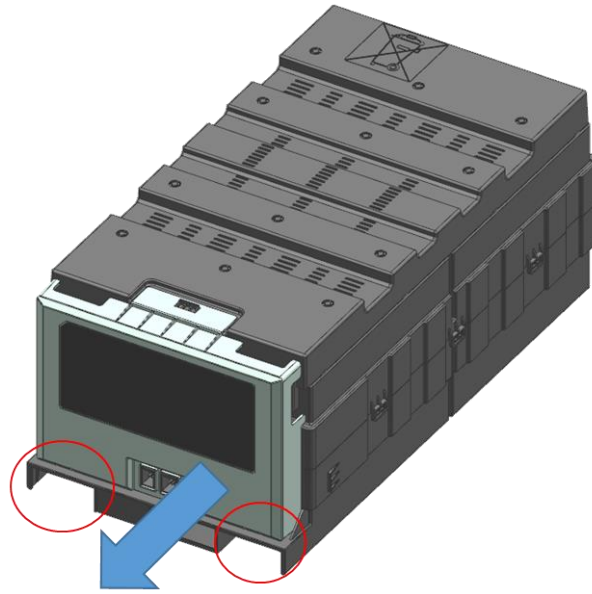

Figure 5-3: Removing the Battery Module Front Cover

3. Make sure that the voltage and temperature sensing wires are firmly inserted into the connector.

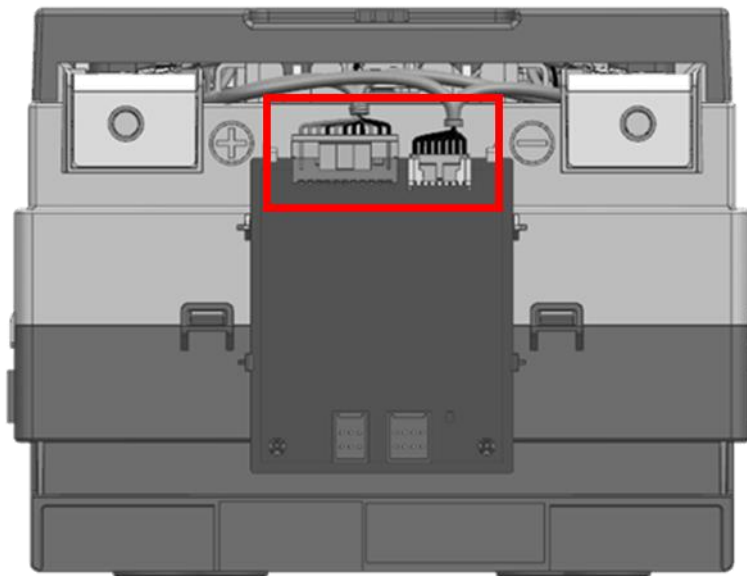

Figure 5-4: Voltage and Temperature Sensing Connectors

### 5.2.2 SMU Connection Check

Check the following points to make sure the SMU is connected correctly.

1. Check the wire connection to the “DC IN” connectors. Both wires must be firmly inserted into the connectors.

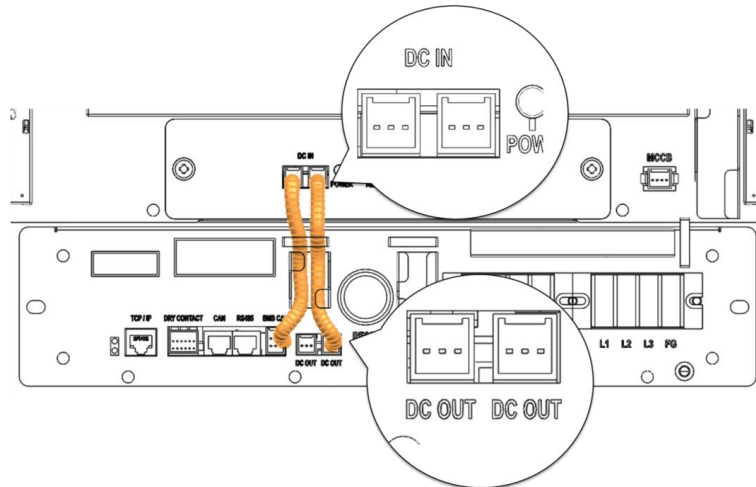

Figure 5-5: DC Power Cables from SMPS Assembly Type A to SMU

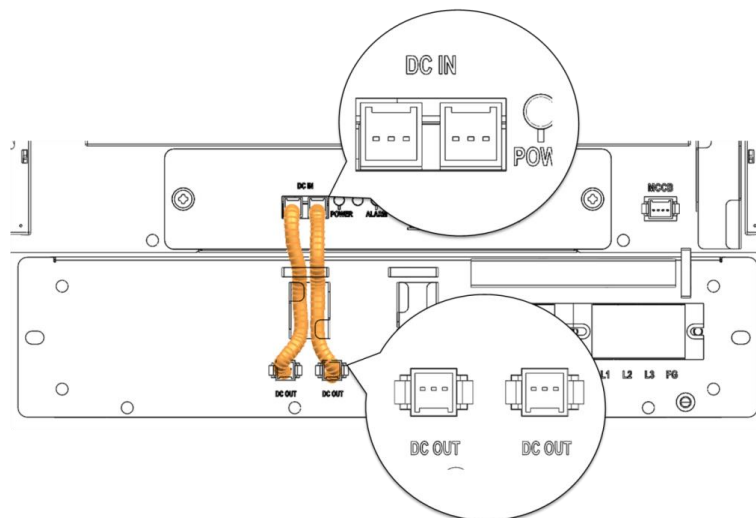

Figure 5-6: DC Power Cables from SMPS Assembly Type B to SMU

2. Check the CAN connections to the SMU. For the rack with the SMPS Assembly Type A, one of the connections must be made to the SMPS Assembly. A termination resistor switch must be turned on in the rack that is farthest from the rack with SMPS Assembly Type A. Refer to Figure 5-9: Termination resistor setting.



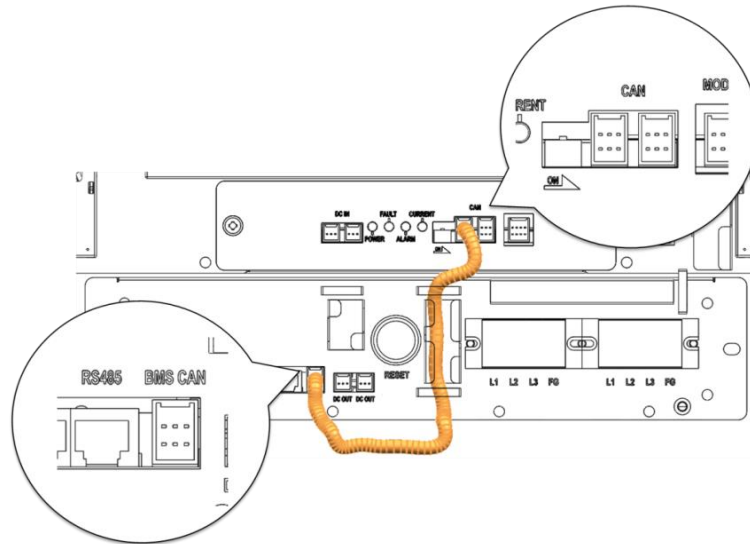

Figure 5-7: CAN Signal Cable Connection from SMPS Assembly to SMU



Figure 5-8: Signal Cabling Examples of Left Alignment of SMUs



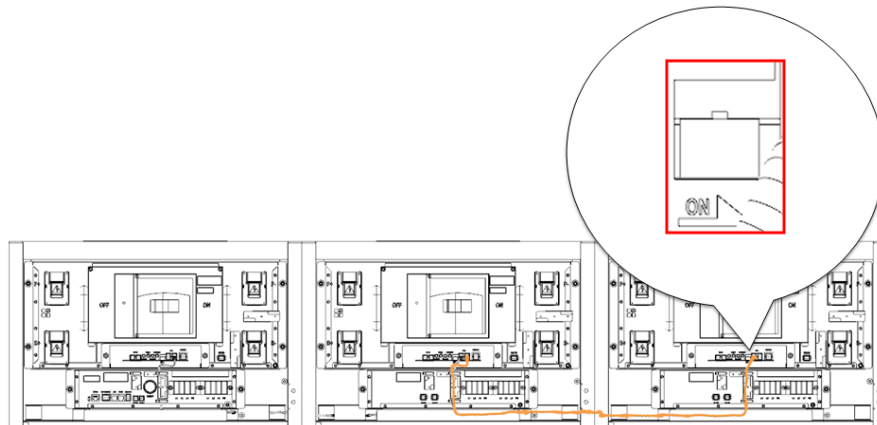

Figure 5-9: Termination resistor setting

### 5.2.3 SMPS Assembly Connection Check

1. Check the wire connection to the “DC OUT” connectors. Both wires must be firmly inserted into the connectors.

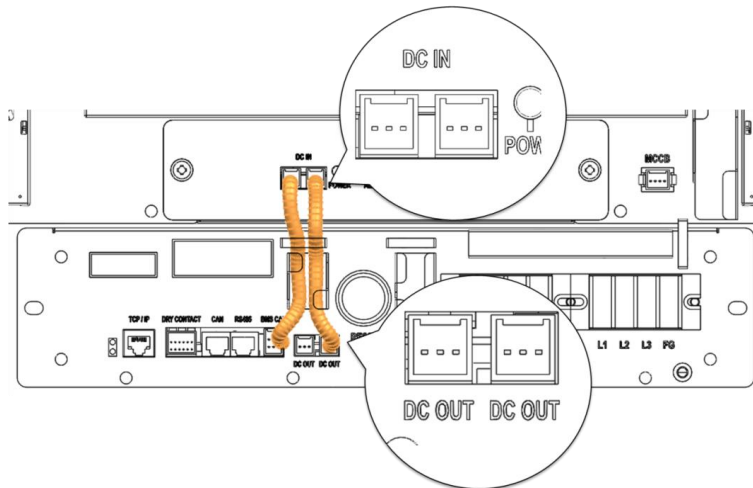

Figure 5-10: DC Power Cables from SMPS Assembly Type A to SMU

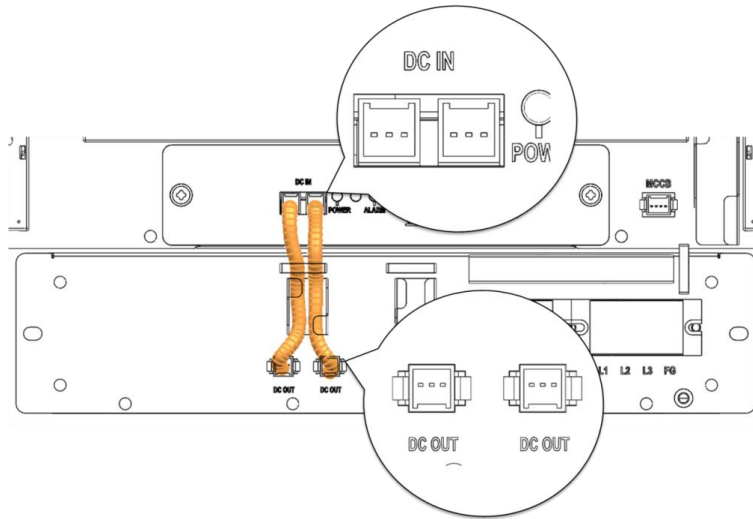

Figure 5-11: DC Power Cables from SMPS Assembly Type B to SMU

2. Check the CAN connections to the SMU.

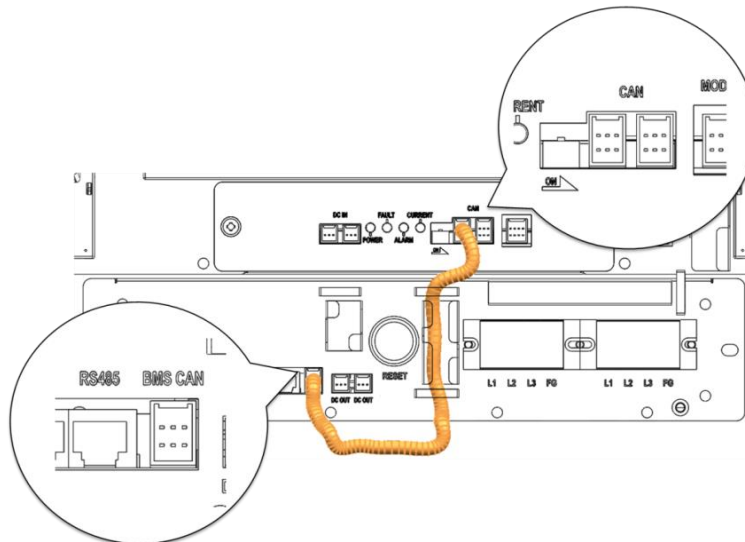

Figure 5-12: CAN Signal Cable Connection from SMPS Assembly to SMU

3. Check the dry contact connector.

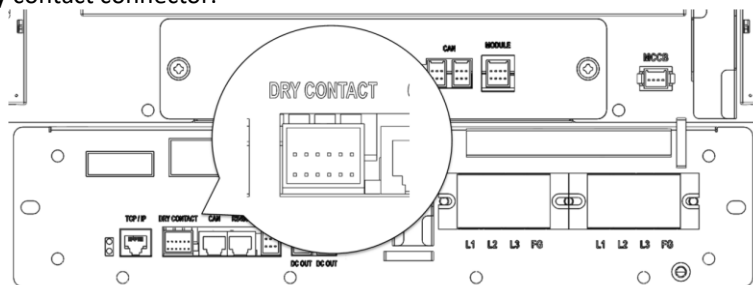



Figure 5-13: Dry Contact Cable Connection to SMPS Assembly

	<b>WARNING</b>
<p>Before checking the AC input terminal connections, make sure they are not energized.</p>	

4. Check the AC input terminal. Remove the protective cover.

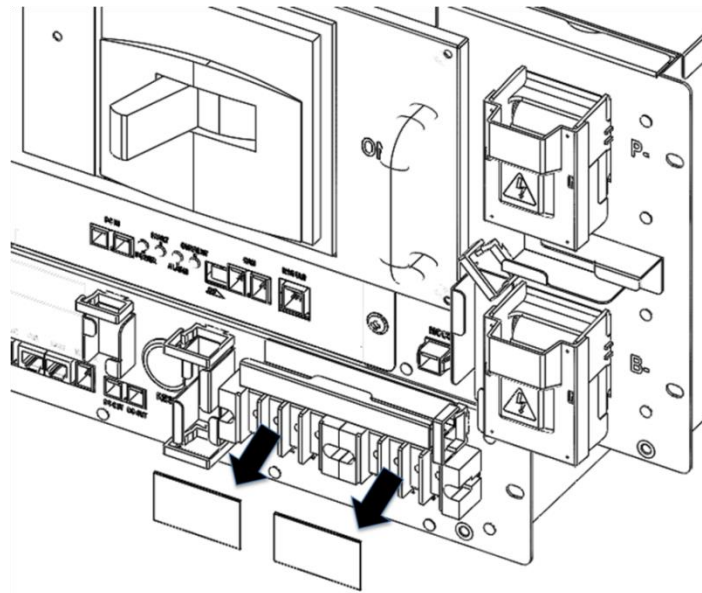

Figure 5-14: AC Input Terminals

5. Check each AC input in the SMPS Assembly.

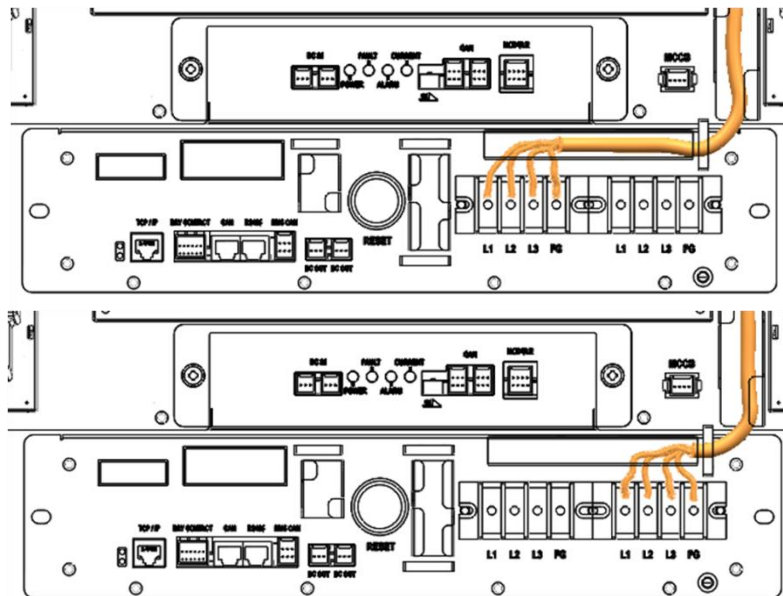

Figure 5-15: AC Input Terminals with Cables Attached

6. Reattach the protective covers to the AC input terminals.

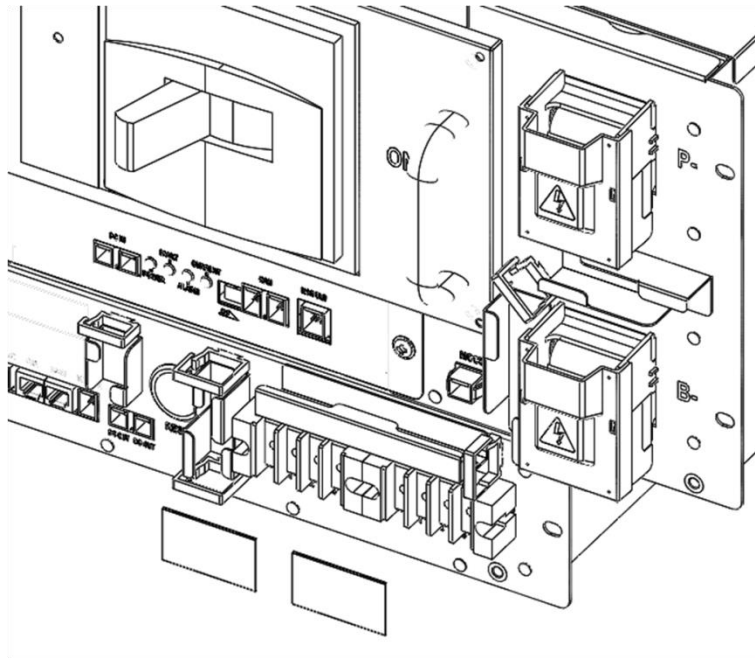

Figure 5-16: AC Input Terminals Protective Covers

## 5.2.4 Busbar Connection Check



**Verify for zero energy state or isolation between racks (strings)!**  
**Make sure that the UPS interface is locked out and tagged out!**

	<b>CAUTION</b>
	<ul style="list-style-type: none"> <li>▪ Follow the instructions exactly to protect the module BMS from damage.</li> <li>▪ Important: DO NOT deviate from the sequence of the steps below.</li> <li>▪ The voltage of the connected system increases proportionally as battery modules are connected. Exercise extreme caution to prevent the terminals from touching anything except their intended mounting points.</li> <li>▪ Terminals and their connected wires have either positive or negative polarity (Positive: B+, P+; Negative: B-, P-). The polarity of a terminal or a wire connected to the terminal is on the front of each module and SMU. Exercise extreme caution to prevent terminals and/or wires with opposite polarity from contacting each other.</li> <li>▪ Do not permit either battery terminal to contact the rack frame because it is possible to contact a connection with the opposite polarity.</li> </ul>

	<b>WARNING</b>
	<ul style="list-style-type: none"> <li>▪ Covers protect the power terminals on Battery Modules and SMU Assemblies to guard against a short circuit. Power terminal covers must be removed before connecting a power busbar. The covers must be reattached immediately.</li> </ul>

Verify that the bolts connecting the busbars are properly torqued..

1. Remove the Battery Module front covers and SMU B+, B-, P+, P- covers.

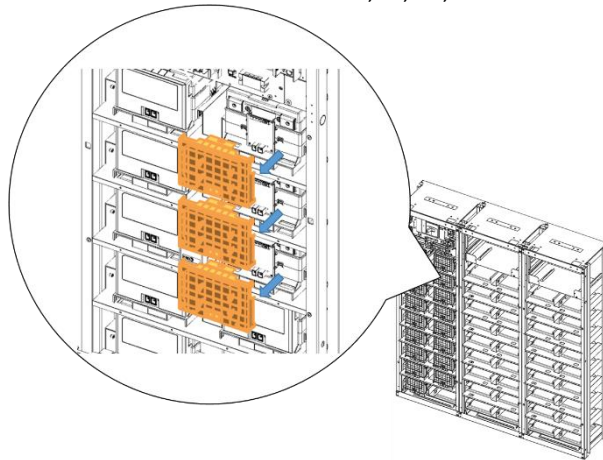



Figure 5-17: Remove the front covers

2. Check the torque settings of the bolts on the busbar.

	<b>NOTICE</b>
	<ul style="list-style-type: none"><li>▪ Connect the power busbar to battery module terminals with an M8 screw.</li><li>▪ The fastening torque should be 8.16–11.94 Nm/80 (117 kgf cm).</li><li>▪ Use an insulated extension torque wrench with a 13 mm socket.</li></ul>

	<b>NOTICE</b>
	<ul style="list-style-type: none"><li>▪ Connect the power busbar to SMU terminals with an M12 screw.</li><li>▪ The fastening torque should be 30 Nm (300 kgf cm).</li><li>▪ Use an insulated extension torque wrench with a 19 mm socket.</li></ul>

3. Reattach the Battery Module front covers and SMU B+, B-, P+, P- covers.

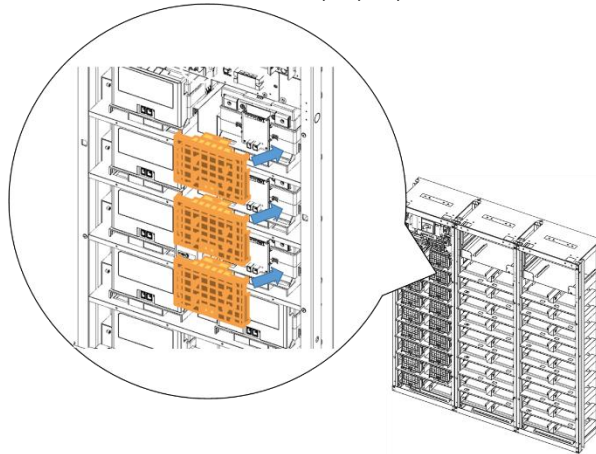

Figure 5-18: Reattach the Front Covers

### 5.2.5 Cell Voltage Balancing

When the battery system is idle – neither charging nor discharging– it will balance the cell voltage if the following conditions are present:

- Minimum cell voltage is above 3.0V.
- Discrepancy between the cell voltage is above the 20mV range.

Cell voltage balancing runs automatically whenever the battery system is idle (neither charging nor discharging).

### 5.2.6 System Reset

To reset the battery system after a major protection fault, press the “reset button” on the front of the SMPS Assembly Type A. This will reset all protection conditions and return the system to normal status.

	<b>NOTICE</b>
	<ul style="list-style-type: none"> <li>Make sure all protection conditions have been cleared before pressing the reset button.</li> <li>Refer to 5.1 Troubleshooting for guides on clearing protection conditions.</li> </ul>

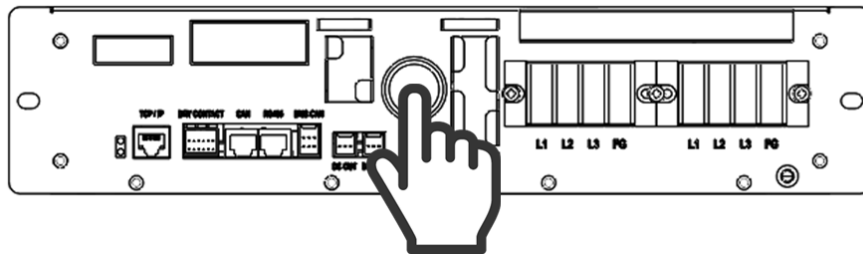





Figure 5-19: Pressing the Reset Button

### 5.2.7 MCCB Handle Control

	<b>CAUTION</b>
	<ul style="list-style-type: none"> <li>Terminals and their connected wires have either positive or negative polarity (Positive: B+, P+; Negative: B-, P-). The polarity of a terminal or a wire connected to the terminal is on the front of each module and SMU. Exercise extreme caution to prevent terminals and/or wires with opposite polarity from contacting each other.</li> <li>Do not permit either battery terminal to contact the rack frame because it is possible to contact a connection with the opposite polarity.</li> </ul>

	<b>WARNING</b>
	<ul style="list-style-type: none"> <li>Covers protect the power terminals on Battery Modules and SMU Assemblies to guard against a short circuit.</li> <li>When handling the MCCB, make sure the covers are installed properly.</li> </ul>

1. Make sure all major protection is cleared by checking the indicator LED in front of the SMU. Before handling the MCCB, verify that the indicator LED is in normal status.

LED Status	Battery Status	Remarks
<div style="display: flex; justify-content: space-around; align-items: center;"> <div style="text-align: center;"> <p>FAULT</p>  <p>POWER</p> </div> <div style="text-align: center;"> <p>CURRENT</p>  <p>ALARM</p> </div> </div> <p>POWER LED Steady</p>	Normal Status	MCCB Off

2. If the MCCB handle is in the “TRIP” position, move the handle to the left “OFF” position. If the MCCB handle is already in the “OFF” position, proceed to the next step.

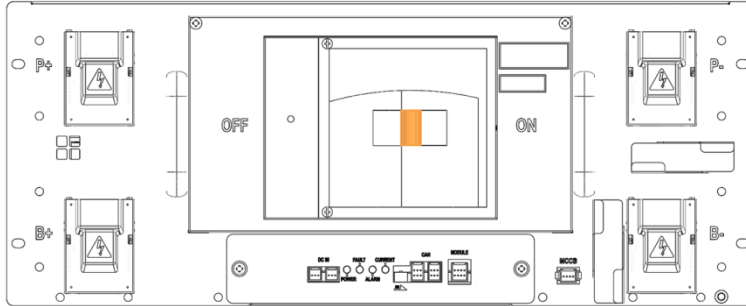

Figure 5-20: MCCB Handle in Trip Position

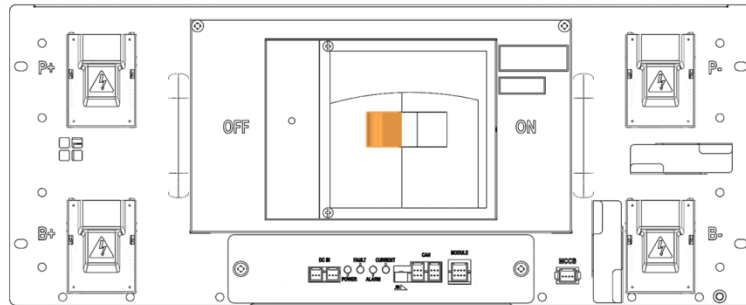

Figure 5-21: MCCB Handle in Off Position

3. Press the handle to the right "ON" position.

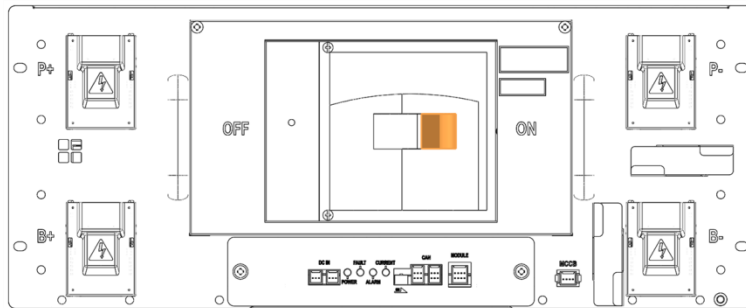
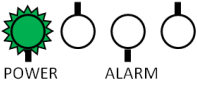



Figure 5-22: MCCB Handle in On Position

4. Check the SMU indicator LED. Make sure that the indicator LED is in normal status and that the MCCB is on.

LED Status	Battery Status	Remarks
<p style="text-align: center;">FAULT    CURRENT</p>  <p style="text-align: center;">POWER    ALARM</p> <p style="text-align: center;">POWER Flashing</p>	Normal Status	MCCB On



## 5.3 Replacement Procedures

	<b>WARNING</b>
	<b>Arc Flash and Shock Hazard</b> Appropriate tools are required while working on this energized equipment.

	<b>WARNING</b>
	<b>Sharp Edges</b> Wear protective gear, including gloves, when working within the battery system enclosures. Sharp edges can exist and may cause severe injury.

	<b>WARNING</b>
	<b>Pinch Point</b> Multiple pinch-points are present in most system components. Be aware that there is a serious risk of injury while working around and in equipment enclosures. These pinch points can cause severe bodily injury.

	<b>CAUTION</b>
	<b>Heavy object</b> Can cause muscle strain or back injury. Use lifting aids and proper lifting techniques when moving trays, batteries and other heavy objects.



**Verify with a voltmeter that no power is present on the system.**  
**Use lock out/tag out procedures to secure the UPS and batteries.**

This section will explain the procedures for disassembly and installation of user-replaceable components. Follow the safety instructions when replacing Battery Modules, Rack Fuse, SMU, and SMPS Assembly. Refer to the installation manual for more details.

### 5.3.1 Wire Harness Replacement

	<b>NOTICE</b>
	<ul style="list-style-type: none"><li>Use only the proper signal cables. These are specified by the part names in the parts list table of the installation manual.</li></ul>

	<b>WARNING</b>
	<p><b>Rack BMS / Module BMS Damage</b> Do not insert both ends of the signal cable WIRE ASSY MODULE TO MODULE #1 or WIRE ASSY MODULE TO MODULE #2 into the same Battery Module.</p>

#### 5.3.1.1 SMU to Module Wire Harness Replacement

1. Remove the signal cable “WIRE ASSY RACK TO MODULE SHIELDING” between the SMU “MODULE” connector and Module #1 “Right Connector”. Press the tab above each end of the connectors and pull the wires out gently.

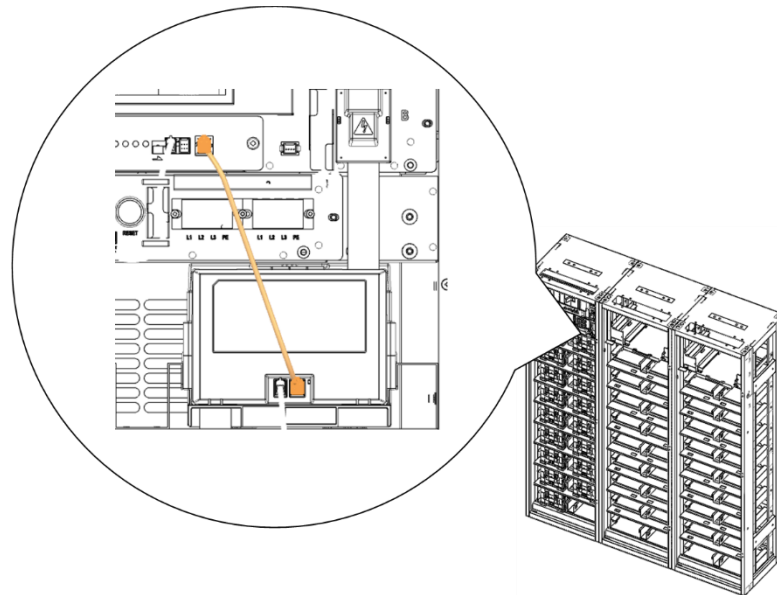

Figure 5-23: Remove SMU to Module #1 Right Connector

2. Install the replacement wire harness signal cable “WIRE ASSY RACK TO MODULE SHIELDING” between the SMU “MODULE” connector and Module #1 “Right Connector”.

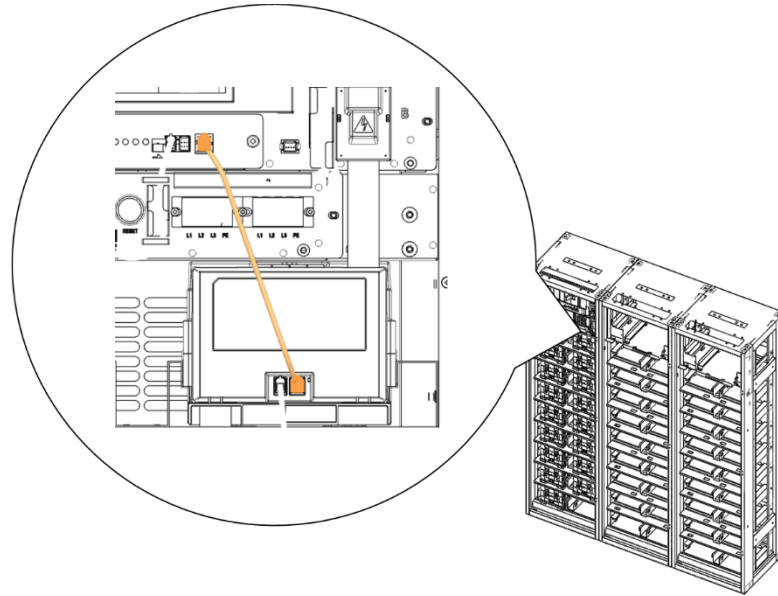

Figure 5-24: Install Signal Cable Between the SMU and Battery Module #1 Right Connector

### 5.3.1.2 Module to Module Wire Harness Replacement

1. Remove the signal cable "WIRE ASSY MODULE TO MODULE."

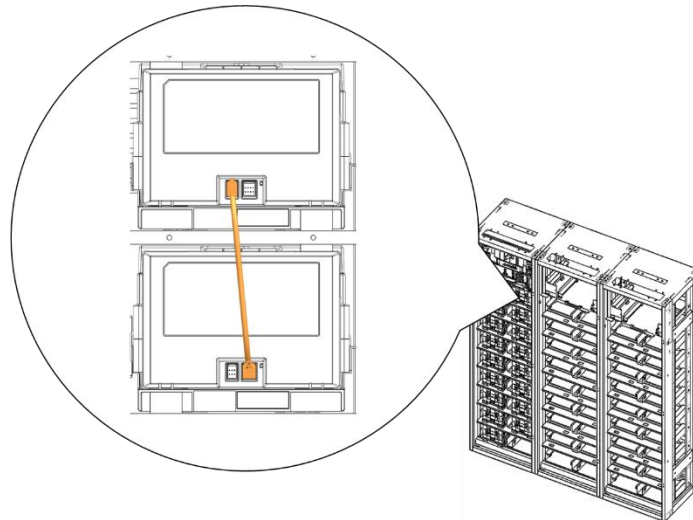

Figure 5-25: Remove Module to Module Signal Cable

2. Install the replacement signal cable "WIRE ASSY MODULE TO MODULE."

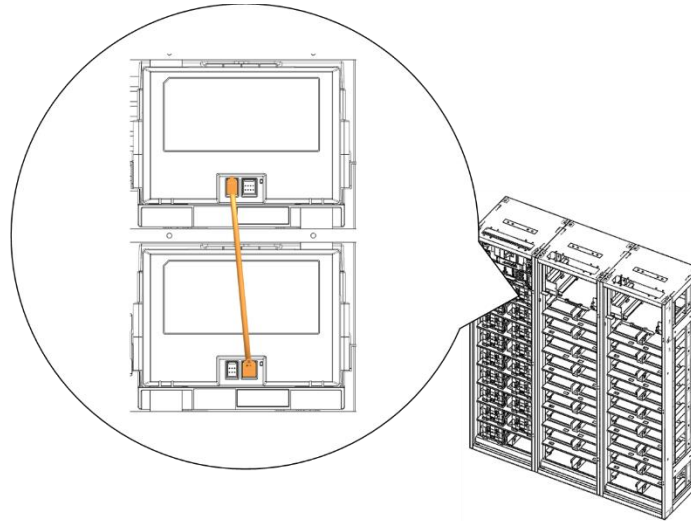

Figure 5-26: Install Module to Module Signal Cable

### 5.3.1.3 SMU to SMU CAN Wire Harness Replacement

1. Remove the CAN wire harness between SMU Assemblies.

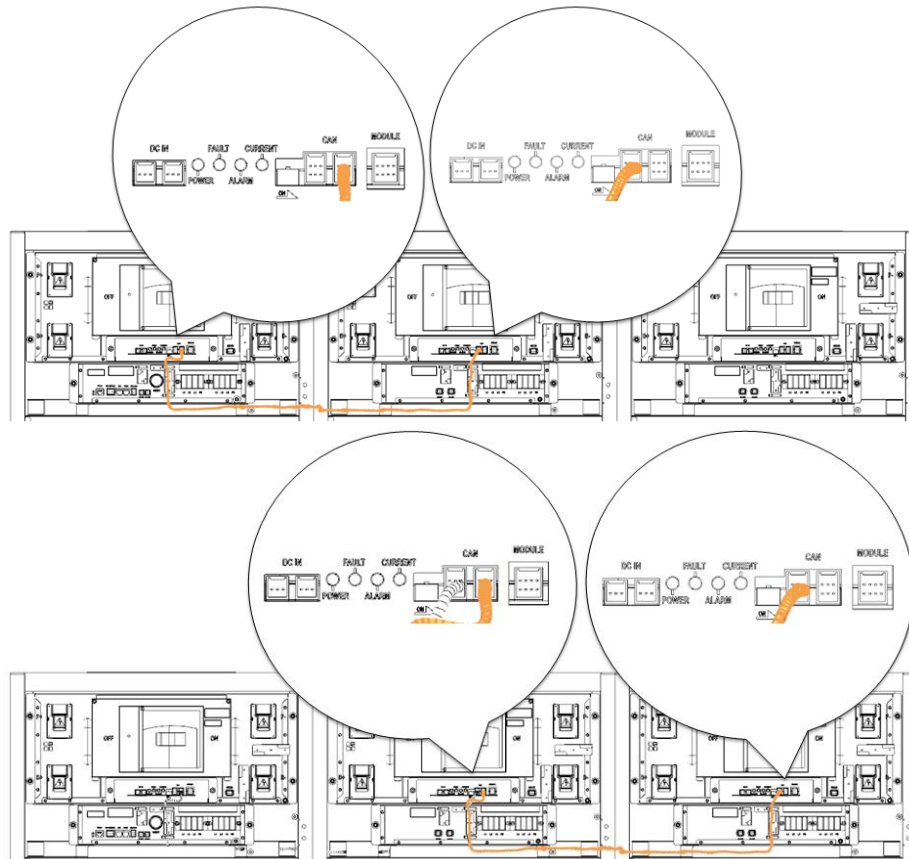

Figure 5-27: CAN Wire Harness Between SMU Assemblies

2. Install the replacement CAN wire harness between SMUs

#### 5.3.1.4 SMU to SMPS Assembly CAN Wire Harness Replacement

1. Remove the CAN wire harness between the SMU and SMPS Assembly.

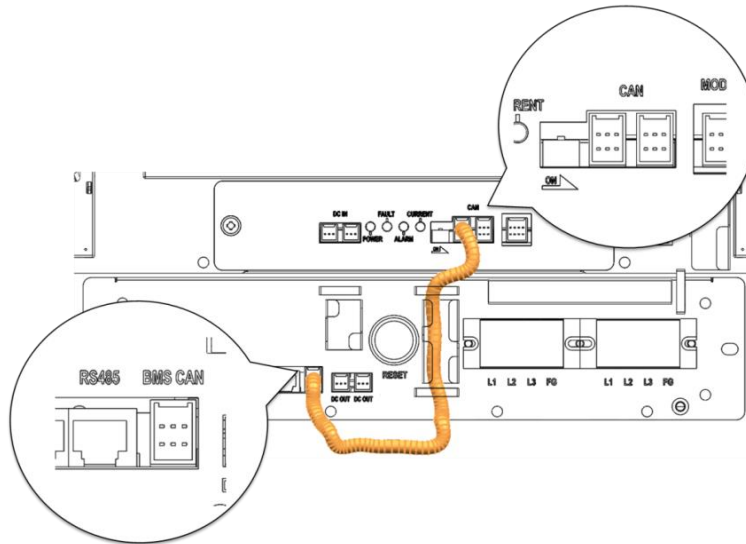

Figure 5-28: CAN Cable Connection from SMPS Assembly to SMU

2. Install the replacement CAN wire harness between the SMU and SMPS Assembly.

### 5.3.1.5 SMU to SMPS Assembly DC Power Wire Harness Replacement

1. Turn the MCCB off.

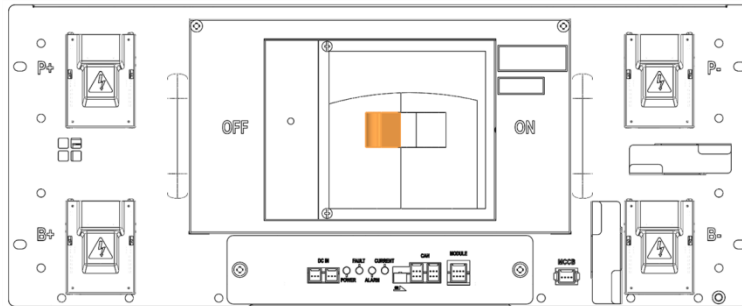

Figure 5-29: MCCB Handle in "OFF" position

2. Remove the DC power wire harness.

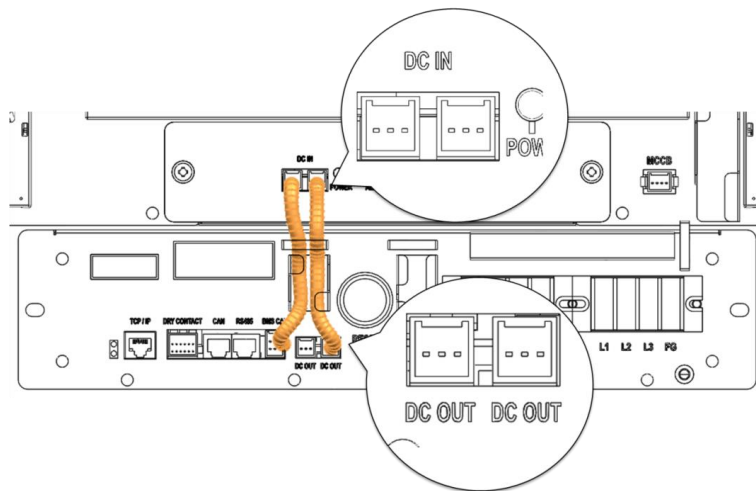

Figure 5-30: DC Power Cables from SMPS Assembly Type A to SMU

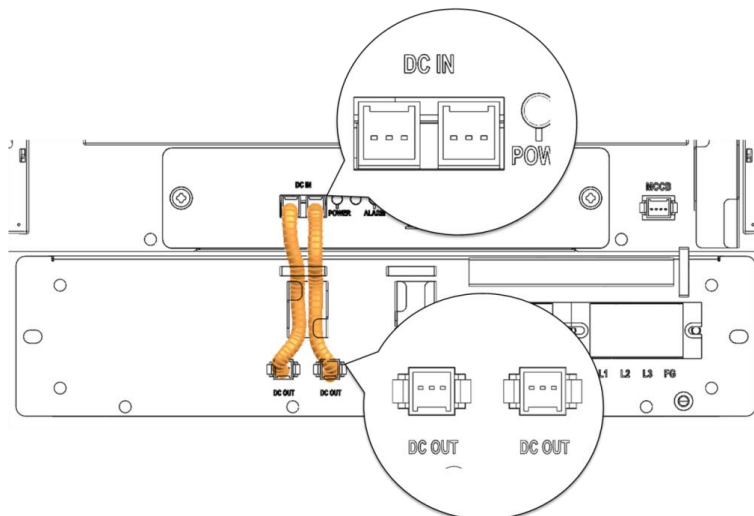

Figure 5-31: DC Power Cables from SMPS Assembly Type B to SMU

3. Install the replacement DC power wire harness
4. Check the indicator LED and make sure it is in normal status.
5. Turn the MCCB on.

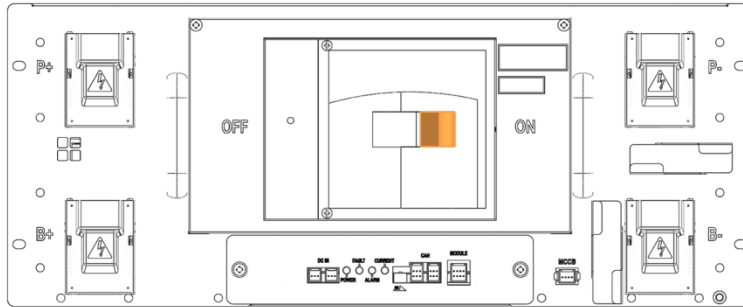





Figure 5-32: MCCB Handle in "ON" Position

### 5.3.2 Battery Module Replacement

	<b>CAUTION</b>
	<ul style="list-style-type: none"> <li>▪ Follow the instructions exactly to protect the Module BMS and Battery Module from damage.</li> <li>▪ DO NOT deviate from the sequence of steps below.</li> <li>▪ The voltage of the connected system increases proportionally as battery modules are connected. Exercise extreme caution to prevent the terminals from touching anything other than their intended mounting points.</li> <li>▪ Terminals and their connected wires have either positive or negative polarity (Positive: B+, P+; Negative: B-, P-). The polarity of a terminal or a wire connected to the terminal is on the front of each module and SMU. Exercise extreme caution to prevent terminals and/or wires with opposite polarity from contacting each other.</li> <li>▪ Do not permit either battery terminal to contact the rack frame because it is possible to contact a connection with the opposite polarity.</li> </ul>

	<b>NOTICE</b>
	<ul style="list-style-type: none"> <li>▪ Connect the power busbar to the Battery Module Terminals with an M8 screw. Use an insulated extension torque wrench with a 13 mm socket.</li> <li>▪ The fastening torque should be 8.16–11.94 Nm (80–117 kgf·cm).</li> </ul>

	<b>NOTICE</b>
	<ul style="list-style-type: none"> <li>▪ Connect the power busbar to the SMU terminals with an M12 bolt. Use an insulated extension torque wrench with a 19 mm socket</li> <li>▪ The fastening torque should be 30 N·m (300 kgf·cm).</li> </ul>

	<b>NOTICE</b>
	<ul style="list-style-type: none"> <li>▪ When charging or discharging the battery module, the following settings must be followed to prevent damaging the battery module.</li> <li>▪ Maximum charge voltage : 33.6V</li> <li>▪ Minimum discharge voltage : 24V</li> <li>▪ Maximum charge current : 22.3A</li> <li>▪ Maximum discharge current : 67A</li> </ul>



4. Identify the defective Battery Module's type. It must be replaced with an identical type of Battery Module.
5. Remove the front cover of the Battery module to determine the type.  
Press the hook on the bus bar opening and pull the front cover towards the front to remove.

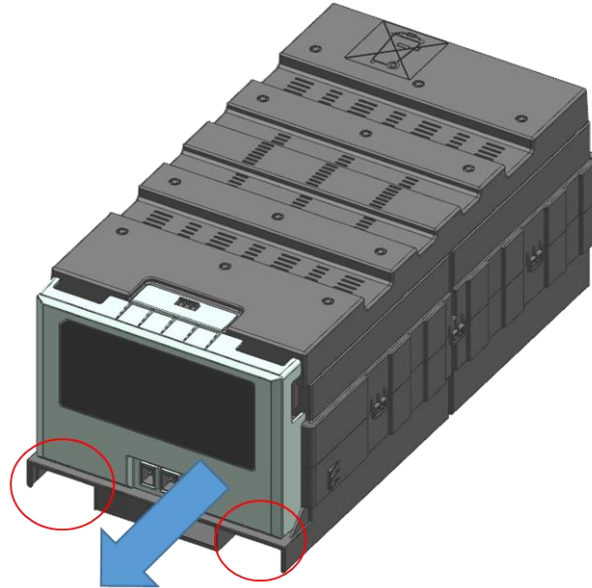

Figure 5-33: Removing the Battery Module Front Cover

6. Type A's positive (+) terminal is on the right side when viewed from the front; Type B's positive (+) terminal is on the left.  
Type A's middle is black; Type B's middle is gray.

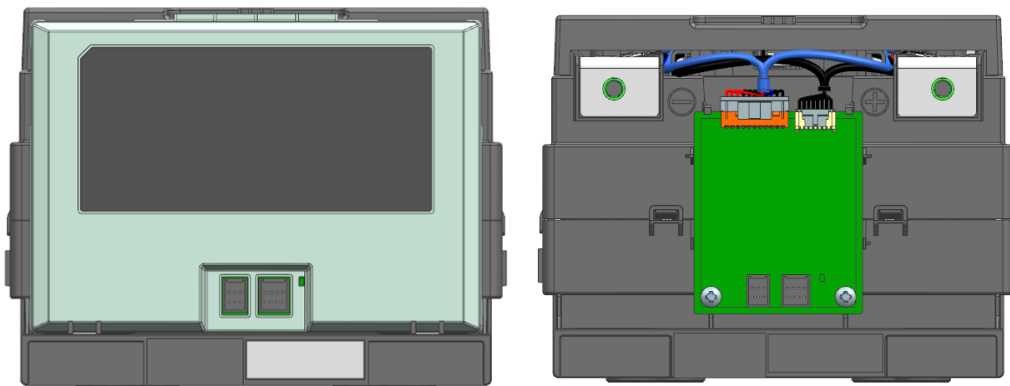

Figure 5-34: Battery Module Type A

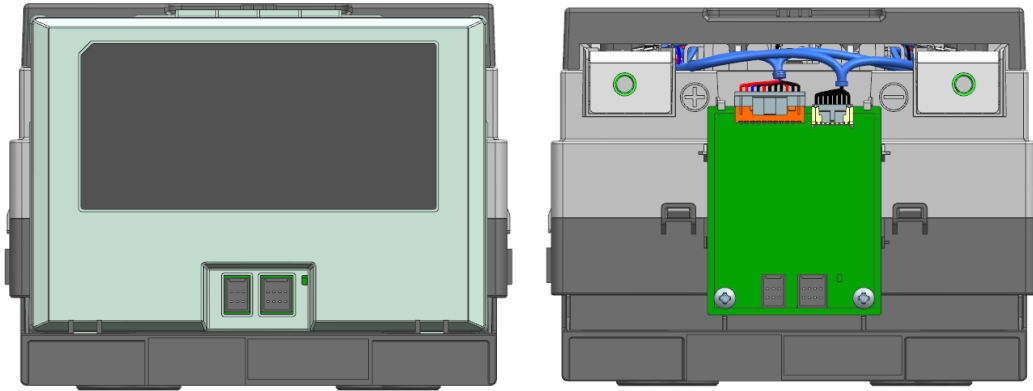

Figure 5-35: Battery Module Type B

7. Turn the MCCB off by pushing the MCCB handle to the "OFF" position.

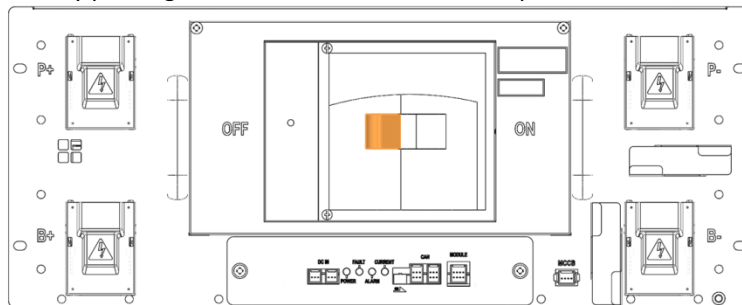

Figure 5-36: MCCB Handle in "OFF" Position

8. Turn off the AC input to the SMPS Assembly.
9. Remove front covers from all Battery Modules.

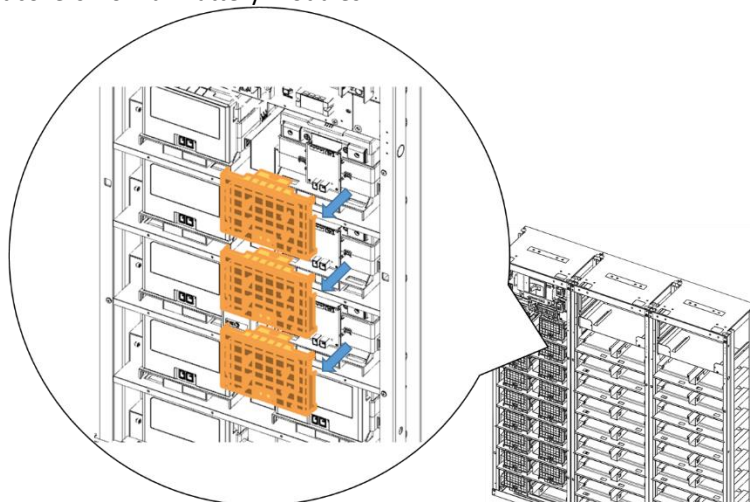

Figure 5-37: Remove Battery Module Front Covers

10. Use a multimeter to measure the voltage of each Battery Module except the defective Battery Module. Record the measurements for reference.

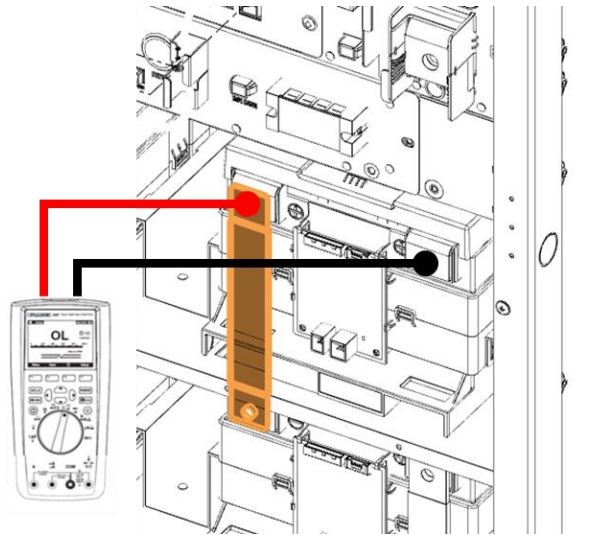

Figure 5-38: Measuring Each Battery Module's Voltage

11. Reattach the front covers to all Battery Modules.

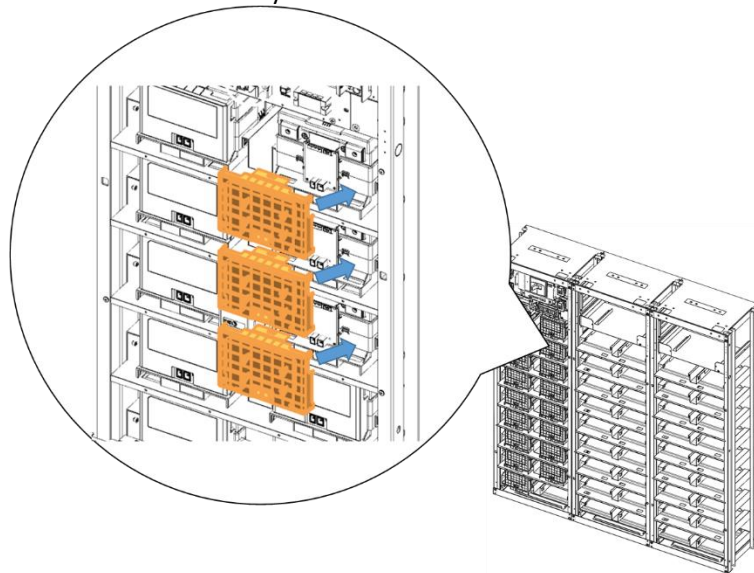

Figure 5-39: Assemble Battery Module Front Covers

12. Charge or discharge the replacement Battery Module to match the average voltage of the other modules.

If the replacement Battery Module's voltage is higher than the other battery modules, use a controllable load to discharge the battery module to match the voltage to within 300mV of the other Battery Modules' average voltage.

If the replacement Battery Module's voltage is lower than the other Battery Modules, use a controllable DC power supply to charge the Battery Module to match the other Battery Modules' average voltage to within 300mV.

When using a DC power supply to charge the battery module directly, use a switch or a circuit breaker between the battery module's terminal and the DC power supply's terminal. Refer to the diagram below.

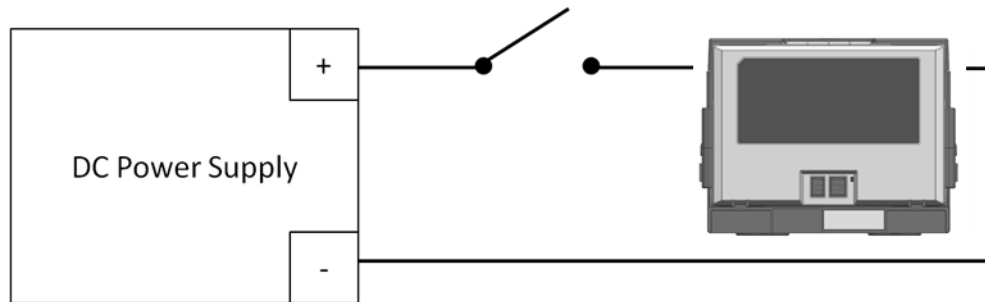

Figure 5-40: DC Power Supply and Battery Module Connection

Before turning the switch or the circuit breaker on, DC power supply's output voltage must match the Battery Module's voltage to prevent inrush current from the battery.

Set the DC power supply's output voltage to the Battery Module's voltage.

Set the output current to 0A.

Turn the DC power supply's output on to pre-charge the capacitors within the power supply.

Turn the switch or circuit breaker on

Raise the output voltage of the DC power supply to the charging voltage.

Set the output current to 22.3A or less.

When the output of the DC power supply reaches the set charging voltage and charging current is decreased to less than 1.34A, stop charging the battery module by disconnecting the switch or circuit breaker.

Turn the DC power supply's output off.

Disconnect the charged battery module

13. Disconnect the control cables from the defective Battery Module.

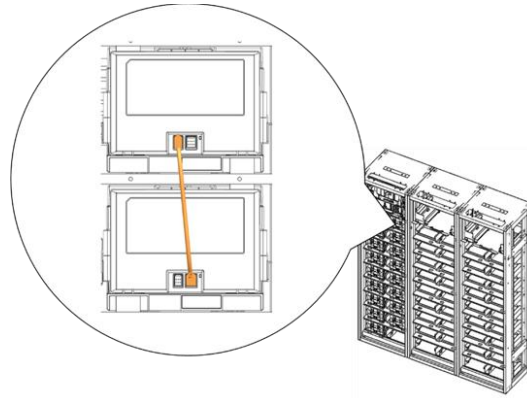

Figure 5-41: Battery Module Signal Cables

14. Remove the front covers from the defective Battery Module and adjacent Battery Modules.

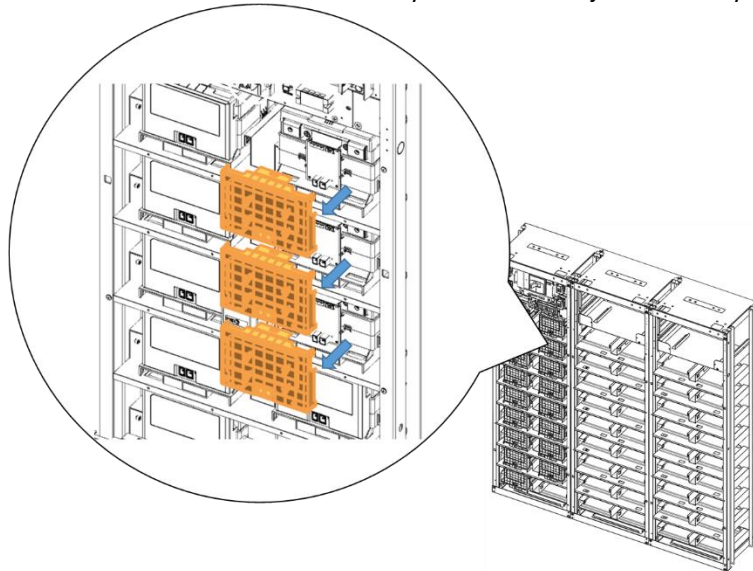

Figure 5-42: Remove Battery Module Front Covers

15. Unbolt the positive and negative busbars from the terminals on the defective Battery Module and the adjacent battery modules.

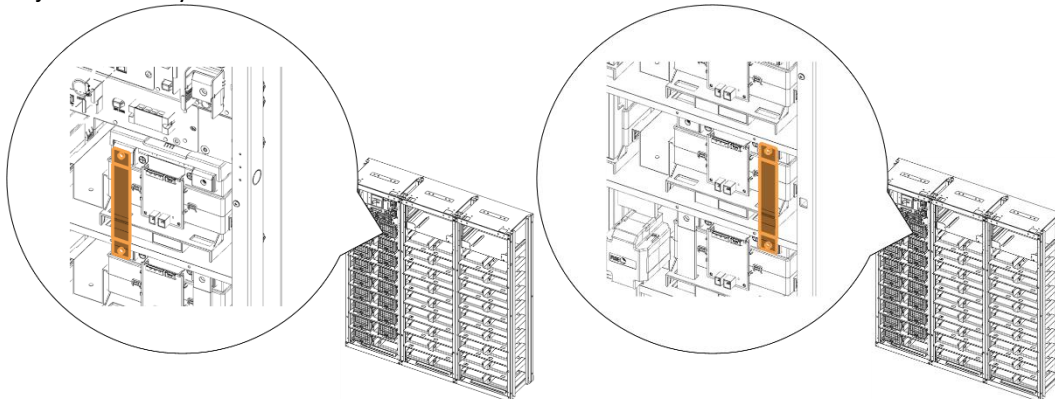
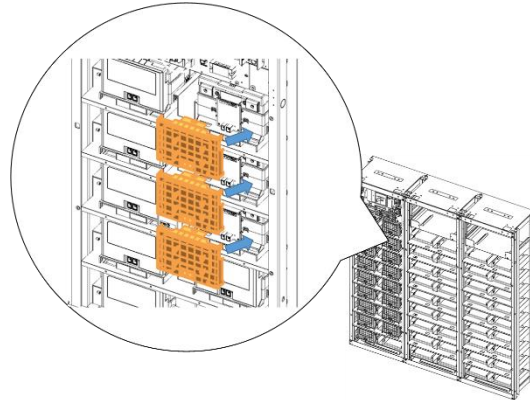

Figure 5-43: Busbars on Positive and Negative Terminals

16. Remove the two busbars.

17. Reattach the battery module front covers



18. Using a rod (a long screwdriver of at least 254mm [10 in.] long may be used), pivot the guide in the Rack Frame to separate the hooks on the Battery Module from the matching hole in the rack frame.

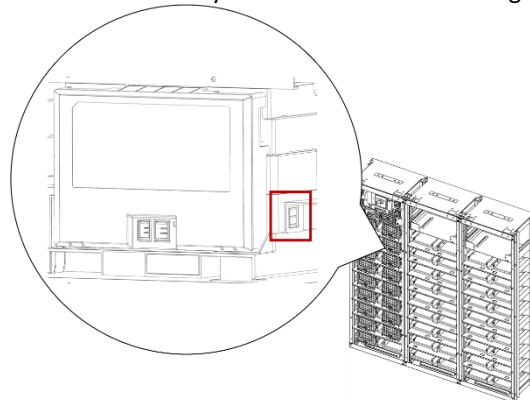
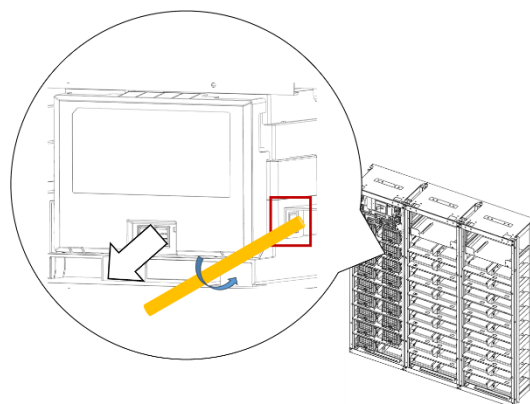

Figure 5-44: Hook and slots on the rack frame



Pivoting the Guide and Pulling the Battery Module Out

19. Pull out the Battery Module while pivoting the guide and remove the Battery Module from the rack frame.

20. Insert the replacement Battery Module.



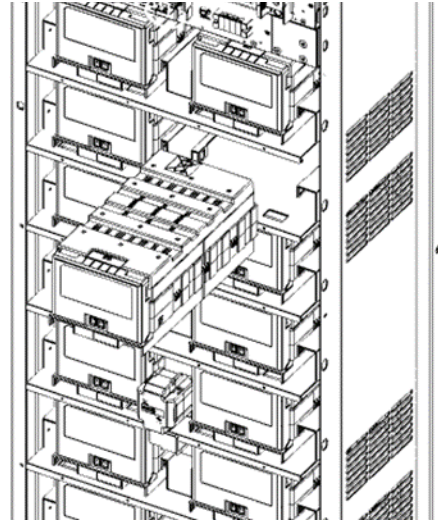

Figure 5-45: Inserting the Replacement Battery Module

21. Remove the front cover from the replacement Battery Module and from adjacent Battery Module.

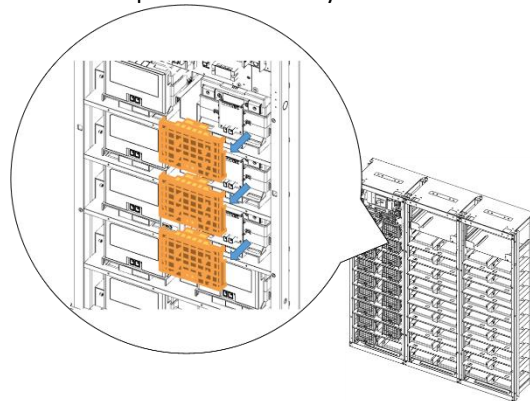

Figure 5-46: Removing the Front Covers

22. Install the busbars.

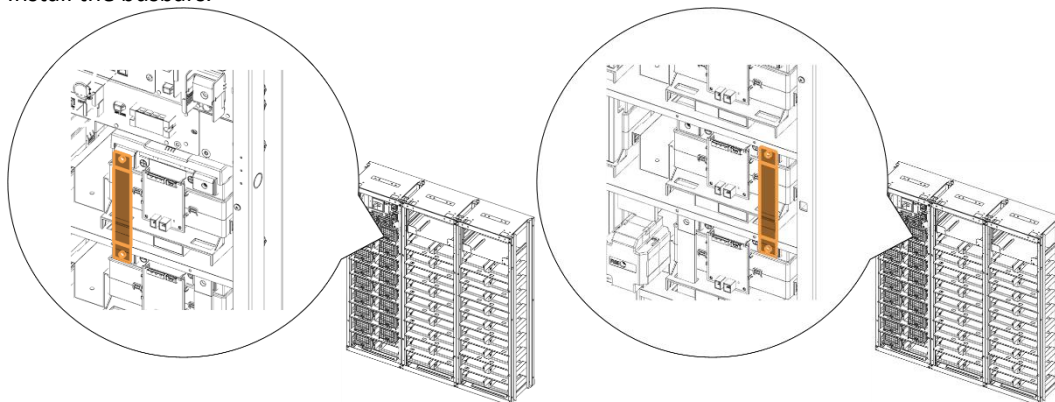

Figure 5-47: Busbars

23. Reattach the front cover to the Battery Module.

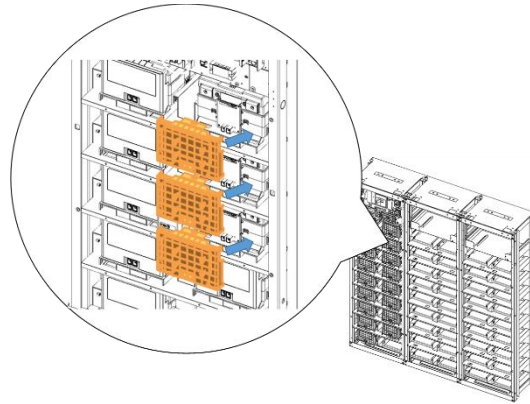

Figure 5-48: Reattaching the Front Cover to the Battery Module

24. Reconnect the signal cables.

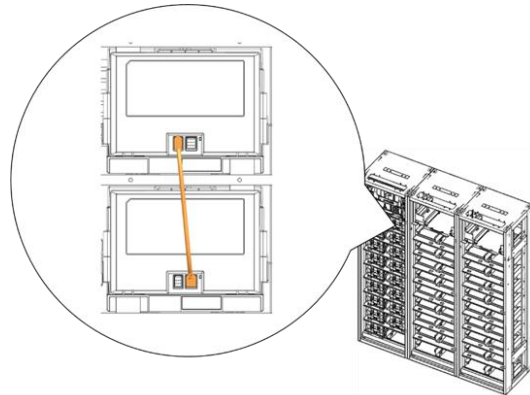

Figure 5-49: Connecting the Signal Cables

25. Turn on the AC input to the SMPS Assembly.

26. Check the indicator LED and make sure it is in normal status.

27. Turn the MCCB handle to the "ON" position.

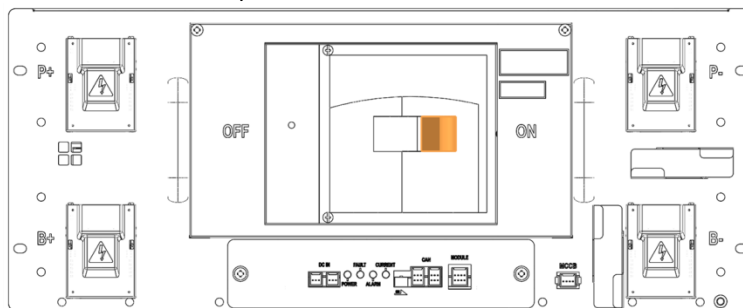



Figure 5-50: MCCB Handle in "ON" Position



### 5.3.3 Rack Fuse / Module Fuse Replacement

	<b>CAUTION</b>
	<ul style="list-style-type: none"> <li>▪ Follow the instructions exactly to protect the Module BMS and Battery Module from damage.</li> <li>▪ DO NOT deviate from the sequence of the steps below.</li> <li>▪ The voltage of the connected system increases proportionally as battery modules are connected. Exercise extreme caution to prevent the terminals from touching anything other than their intended mounting points.</li> <li>▪ Exercise extreme caution to prevent terminals and wires from contacting a wire or terminal with the opposite polarity.</li> <li>▪ Do not permit either battery terminal to contact the rack frame because it is possible to contact a connection with the opposite polarity.</li> </ul>

	<b>NOTICE</b>
	<p>The Rack Fuse Busbar Assembly is assembled at the installation site using M12 x 16L screws. The fastening torque should be 30 Nm (300 kgf cm).</p>

1. Turn the MCCB off. If multiple strings are installed in parallel, turn the MCCB off for all racks.

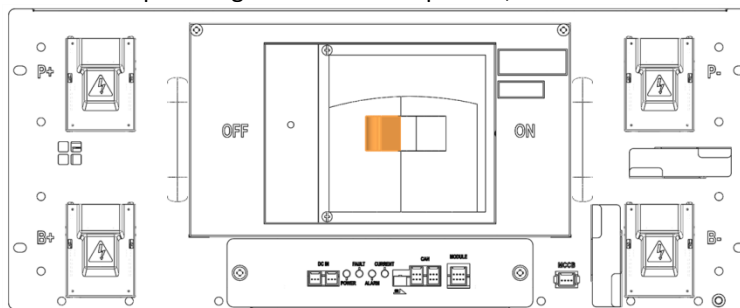

Figure 5-51: MCCB Handle in "OFF" Position

2. Turn off the AC input to the SMPS Assembly.
3. Remove front covers from the Battery Modules adjacent to the rack fuse.

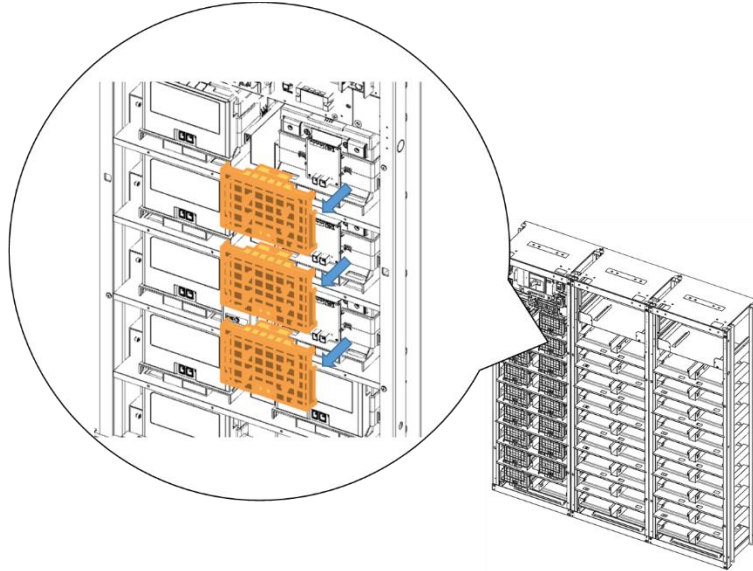

Figure 5-52: Remove the Battery Module Front Covers

4. Remove the bolts from the Battery Module terminals that are connected to the rack fuse.
5. Remove the rack fuse assembly.
6. Remove the busbars and bolts attached to the rack fuse and reattach the busbars and bolts to the replacement rack fuse.
7. Attach the replacement rack fuse with busbars attached.
8. Assemble the bolts for the Battery Module terminals.
9. Reattach the front covers to the Battery Modules.
10. Reattach the rack fuse cover.
11. Turn on the AC input to the SMPS Assembly.
12. Check the SMU indicator LED and make sure it is in normal status.
13. Turn the MCCB handle to the "ON" position.

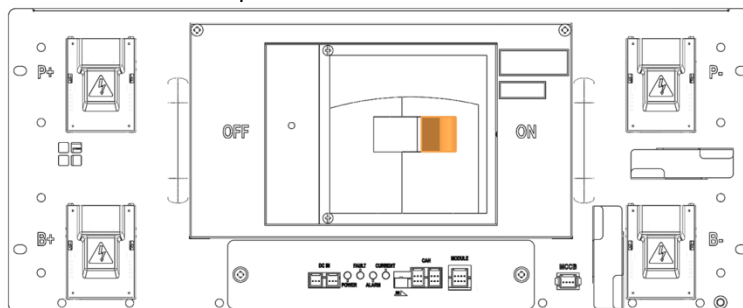

Figure 5-53: MCCB Handle in "ON" Position



### 5.3.4 SMU Replacement

1. Turn the MCCB off. If multiple strings are installed in parallel, turn the MCCB off for all racks.

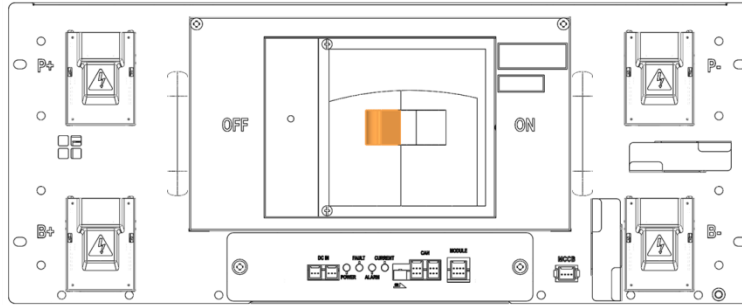

Figure 5-54: MCCB Handle in "OFF" Position

2. Remove the DC input and communication wires from the Battery Module, the adjacent rack and the SMPS Assembly.

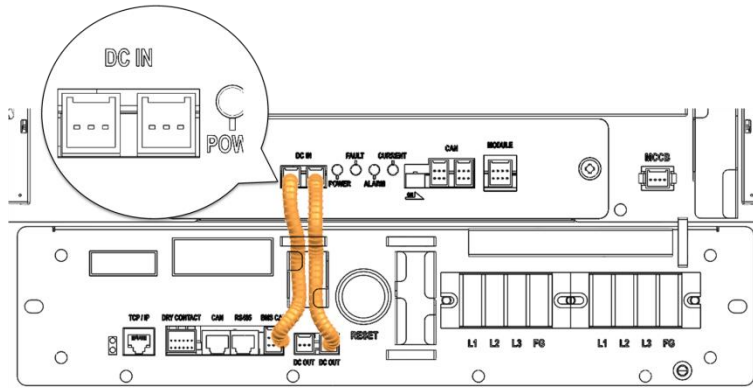

Figure 5-55: DC IN Cable

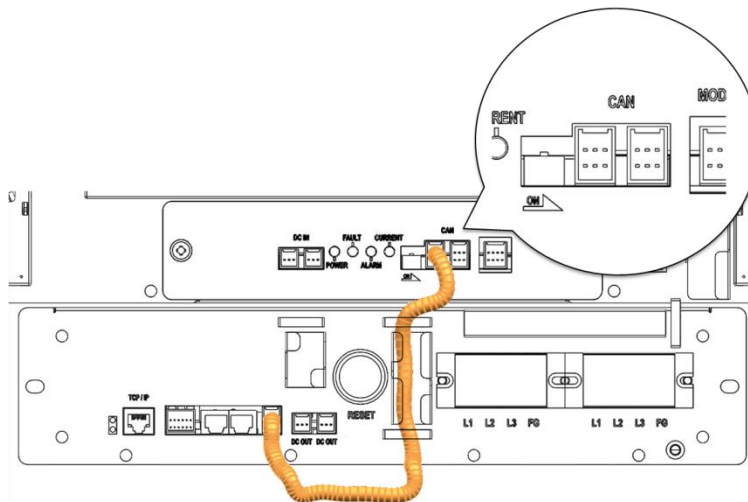

Figure 5-56: CAN Cable to SMPS Assembly

Figure 5-57: CAN Cable to Adjacent Rack

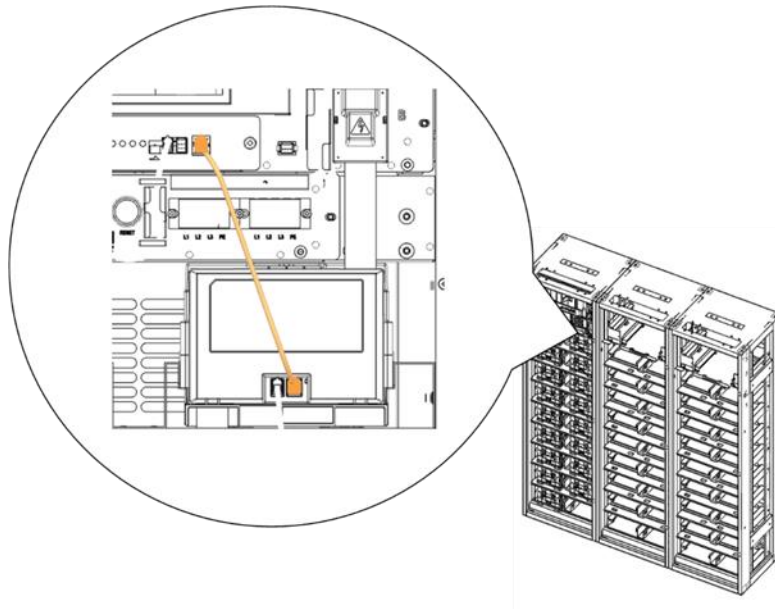

Figure 5-58: Module Signal Cable

3. Remove the front cover from the Battery Module on the ninth shelf.
4. Remove the bolts from B+ on Battery Module #16, and from B- on Battery Module #1.
5. Remove terminal covers from the battery terminals.

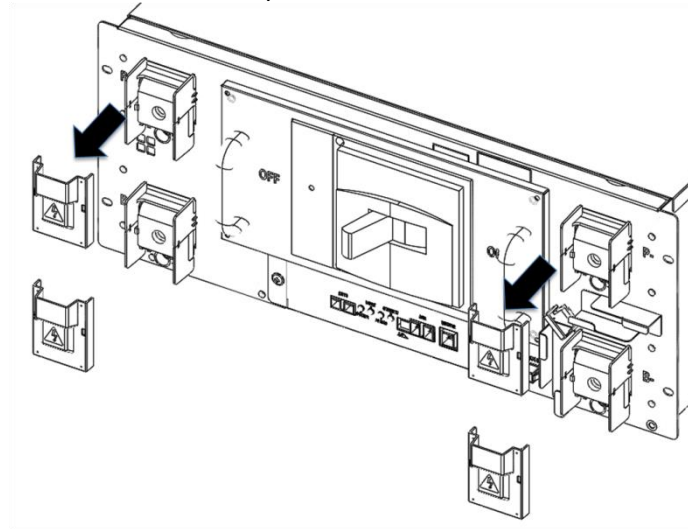

Figure 5-59: SMU Terminal Covers

6. Hold the busbar on its insulated portion and remove the bolts from the terminals for B+, B- terminals.
7. Remove the busbars.

8. Remove the connections to P+, P- terminals. Make sure there is adequate clearance in front of the SMU for its easy removal.

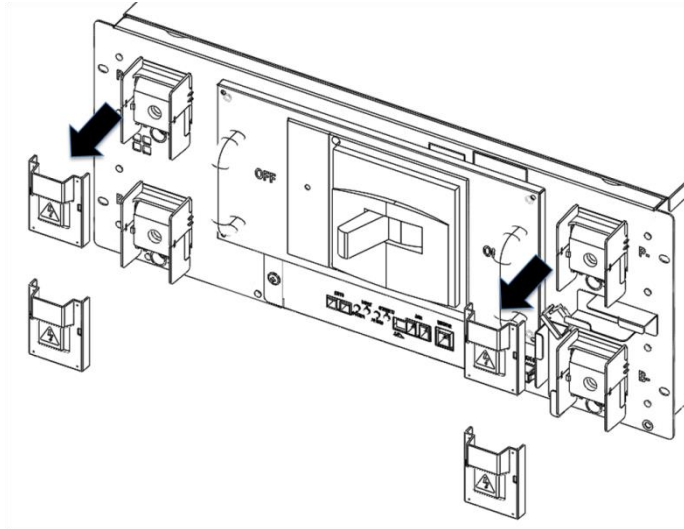

Figure 5-60: P+, P- Terminals

9. Remove screws from the SMU and its ground cable.
10. Remove the SMU and insert its replacement.
11. Insert and tighten the screws on the SMU and its grounding cable.
12. Reattach the busbars and reinstall the bolts for B+ for Battery Module #16, and B- for Battery Module #1.
13. Reinstall the bolts for B+ and B- terminals.
14. Reinstall the bolts for P+ and P- terminals.
15. Reattach the terminal covers.

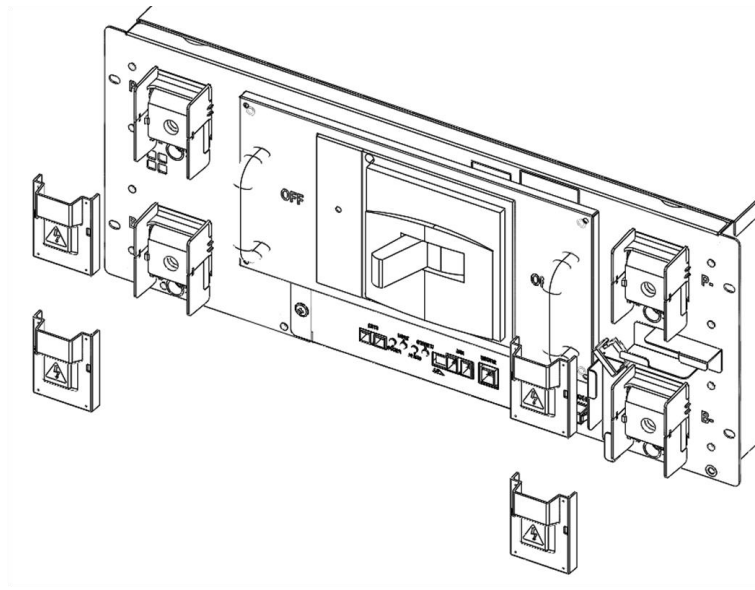

Figure 5-61: B+, B-, P+, P- Terminal Connections and Terminal Covers

16. Reattach the signal cables to the Battery Module, adjacent rack, SMPS Assembly, and DC IN cable.

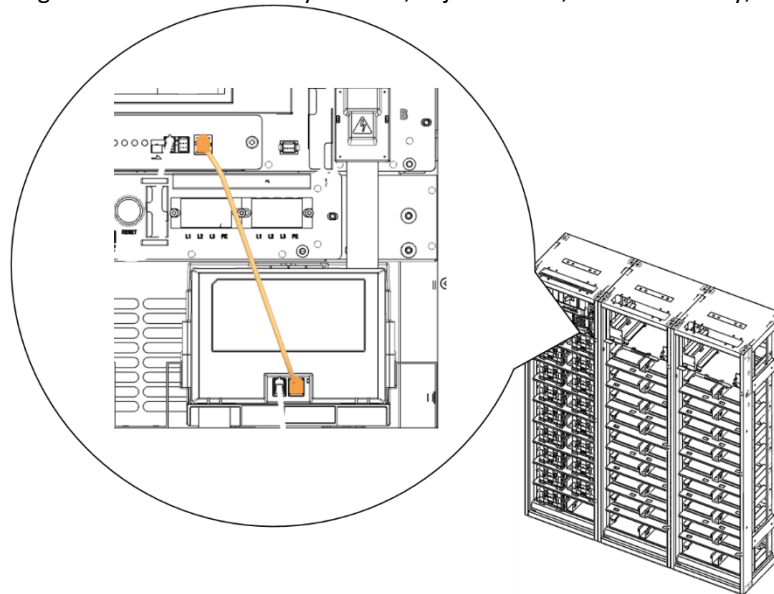

Figure 5-62: SMU to Module Signal Cable

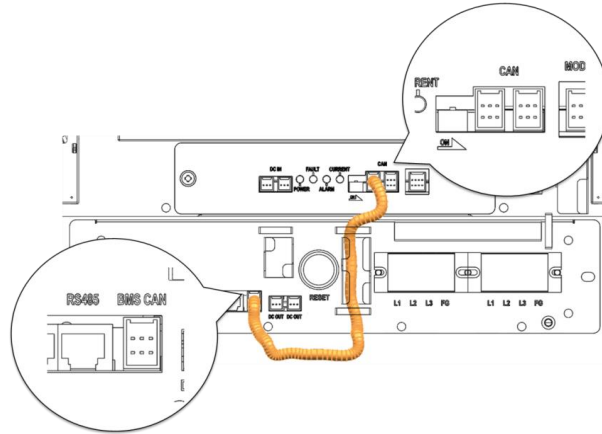

Figure 5-63: SMU to SMPS Assembly CAN Signal Cable

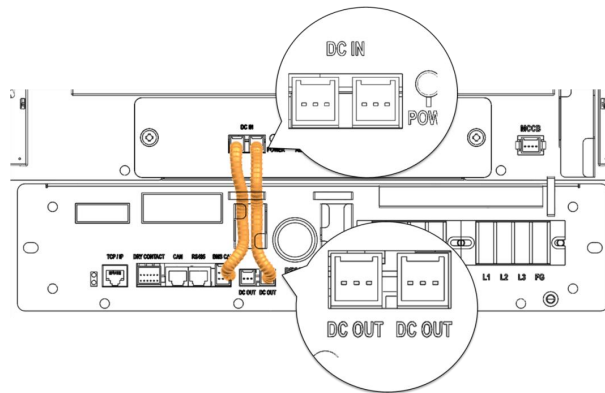

Figure 5-64: DC Power Cables from SMPS Assembly Type A to SMU

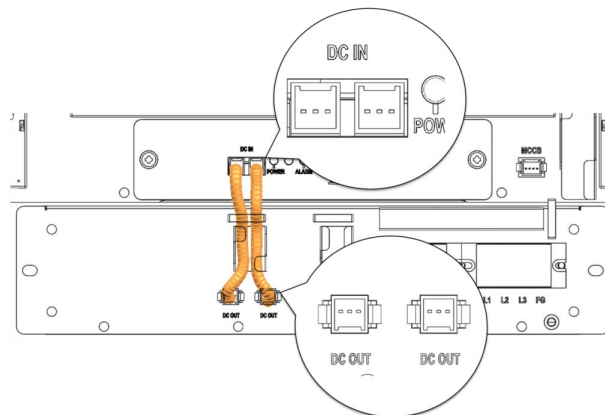

Figure 5-65: DC Power Cables from SMPS Assembly Type B to SMU

17. Check the indicator LED and make sure it is in normal status.
18. Turn the MCCB handle to “ON” position.



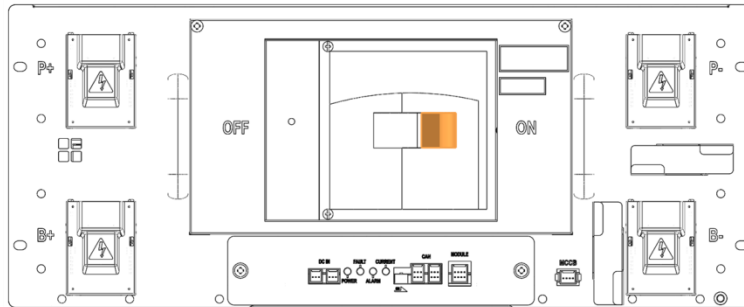



Figure 5-66: MCCB Handle in “ON” Position

19. The Rack BMS in the replacement SMU must be configured according to the rack configuration. Refer to the “Installation Manual” for details.

### 5.3.5 SMPS Assembly Replacement

	<b>NOTICE</b>
<p>SMPS Assembly 3 Phase Type A is used as a reference. Similar steps are used for SMPS Assembly 3 Phase Type B, SMPS Assembly 1 Phase Type A and B.</p>	

1. Turn off the MCCB.

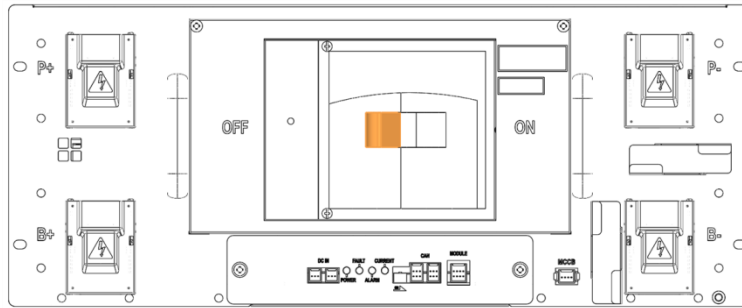



Figure 5-67: MCCB Handle in "OFF" Position

2. Turn off the AC input to the SMPS Assembly.

	<b>WARNING</b>
<p>Before working on the AC input terminal connections, use a voltmeter to verify that they are not energized.</p>	

3. Remove the protective covers from the AC input terminals.

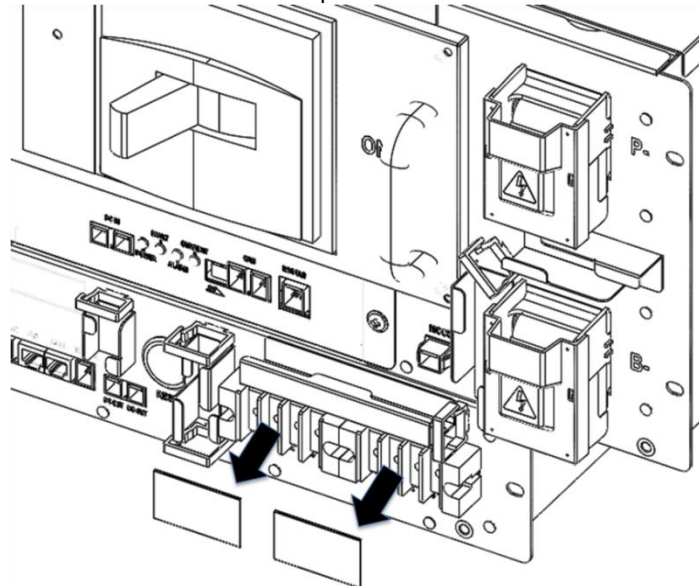

Figure 5-68: AC Input Terminals

- Remove the AC input cables. Make sure the AC cables are not energized.

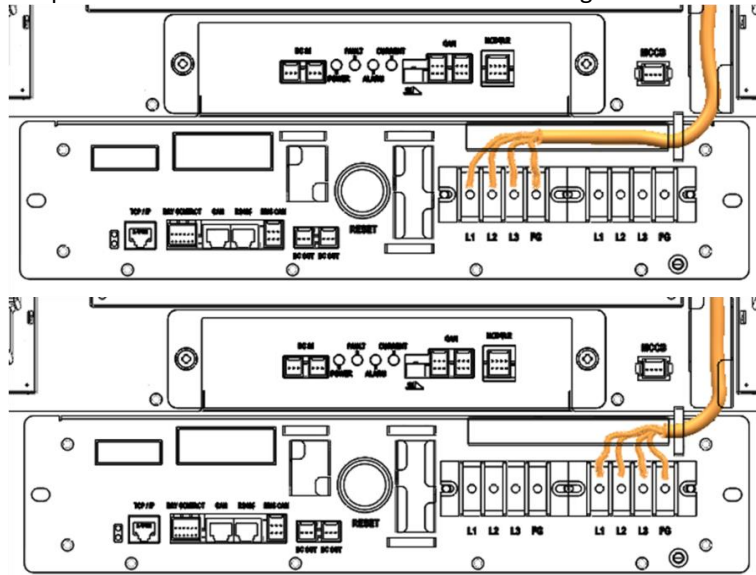

Figure 5-69: Cables to the AC Input Terminals

- Remove the DC OUT connection.

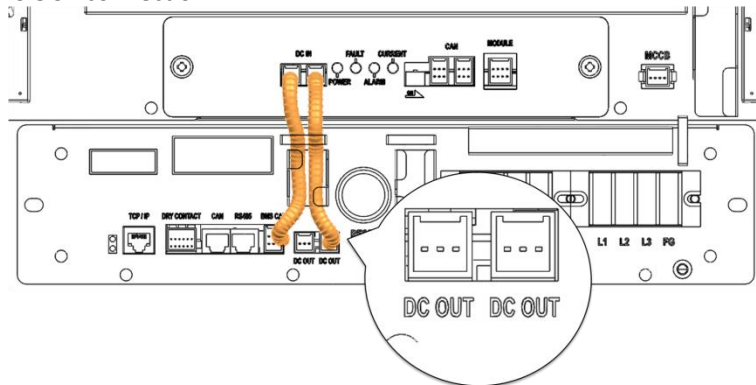

Figure 5-70: DC OUT Connection

- Remove the BMS CAN connection.

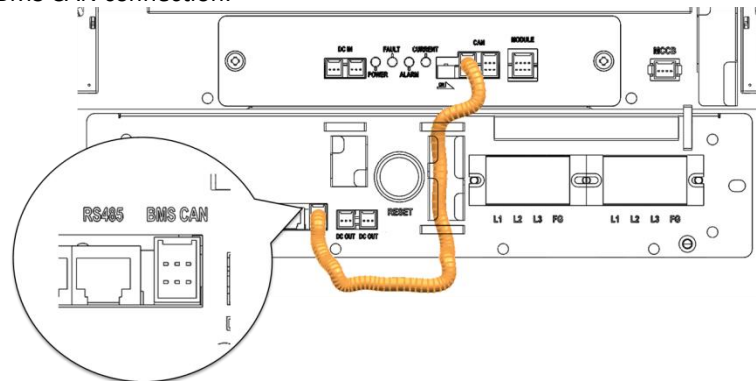

Figure 5-71: BMS CAN Connection



- Remove the TCP/IP connection.

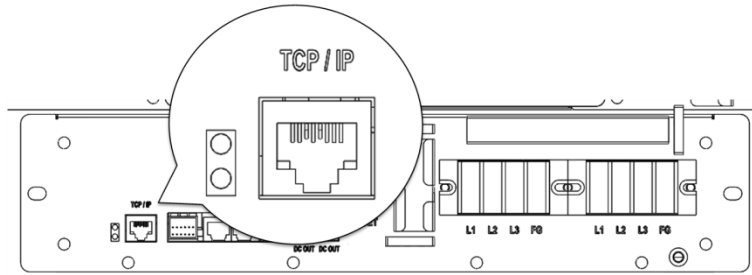

Figure 5-72: TCP/IP Connection

- Remove the dry contact connection.

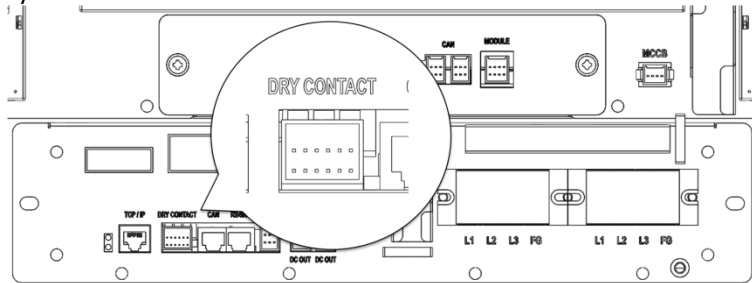

Figure 5-73: Dry Contact Connection

- Unscrew the SMPS Assembly from the rack frame.

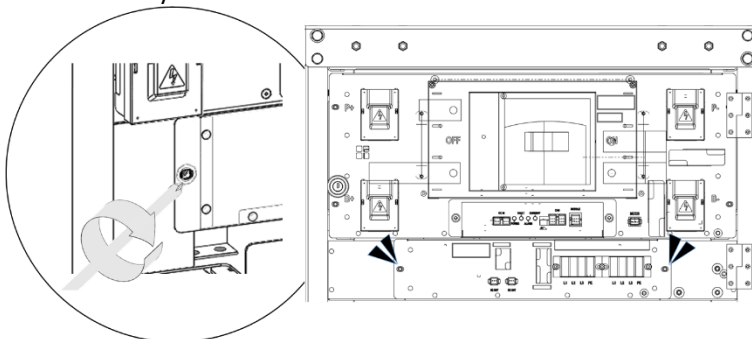

Figure 5-74: Unscrew SMPS Assembly

10. Detach the grounding cable from the rack frame.

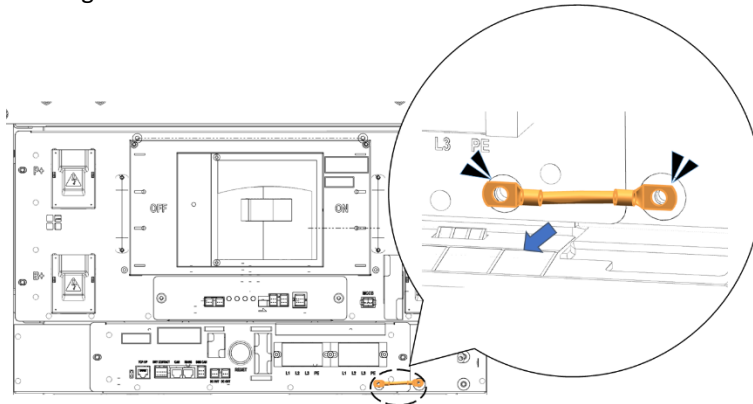

Figure 5-75: Unscrew SMPS Assembly Grounding Cable

11. Remove the SMPS Assembly.

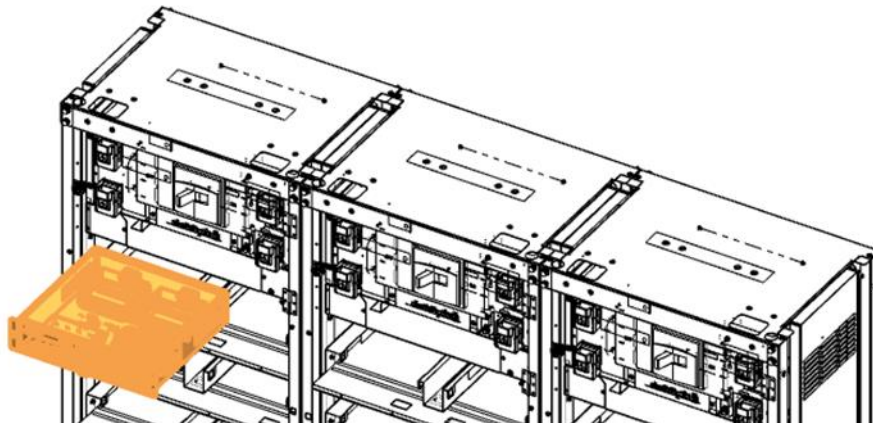

Figure 5-76: Remove the SMPS Assembly

12. Insert the replacement SMPS Assembly into the rack frame on the shelf designated for it.

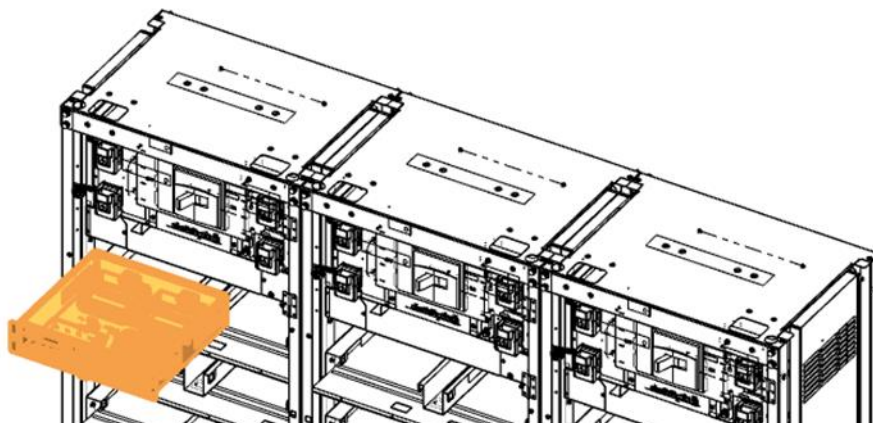

Figure 5-77: Insert the SMPS Assembly

13. Attach the SMPS Assembly to the rack frame using screws and torque them to 5.1–6.1 Nm (50–60 kgf cm).

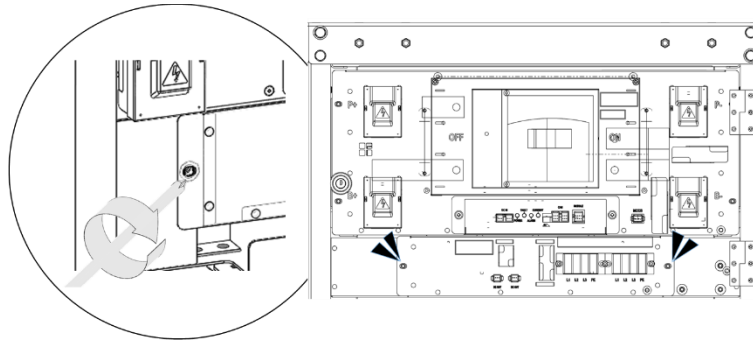

Figure 5-78: Screw on the SMPS Assembly

14. Connect the ground cable to the SMPS Assembly.

	<p><b>NOTICE</b></p> <p>Connect a ground cable between the SMPS Assembly and the Rack Frame using SCREW M5 x 10L. Torque the screw to 5.1–6.1 Nm (50–60 kgf cm). Double-check that the torque setting is correct.</p>
--	---

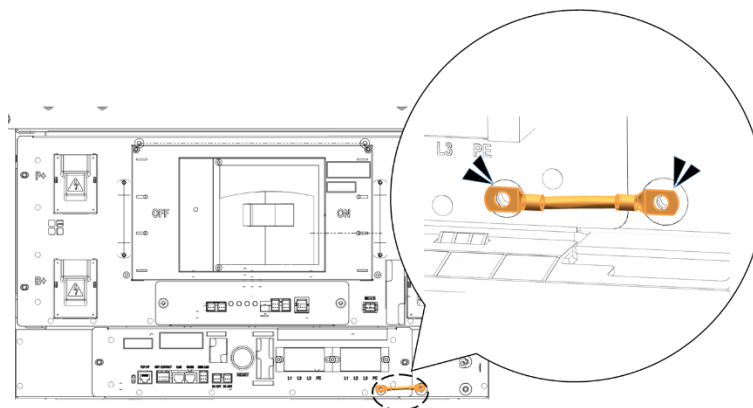

Figure 5-79: Screw on the SMPS Assembly Grounding Cable

15. Connect the SMU DC power cables.

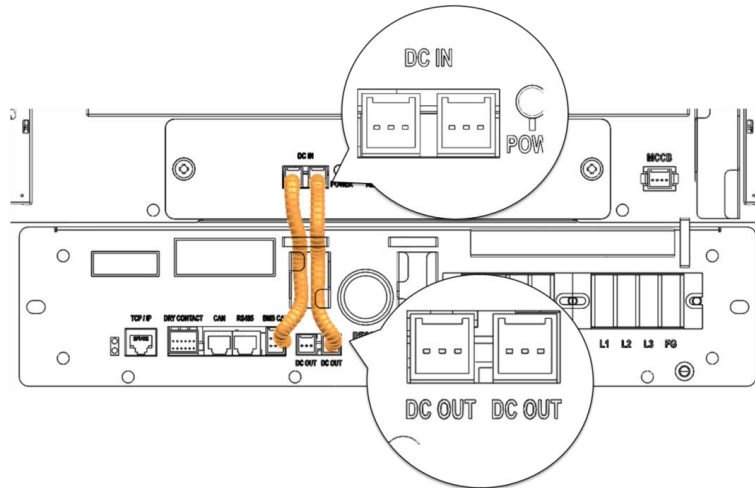

Figure 5-80: DC Power Cables from SMPS Assembly Type A to SMU

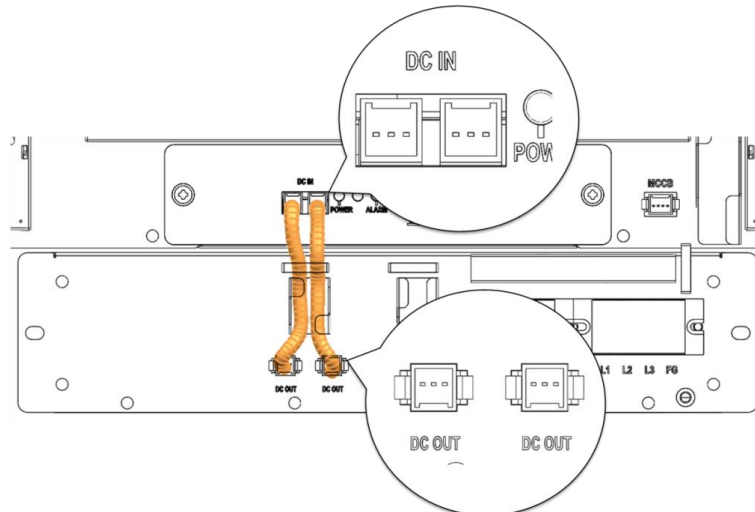

Figure 5-81: DC Power Cables from SMPS Assembly Type B to SMU

16. Connect the signal cable from the SMPS Assembly to the SMU "WIRE ASSY RACK TO SYSTEM."



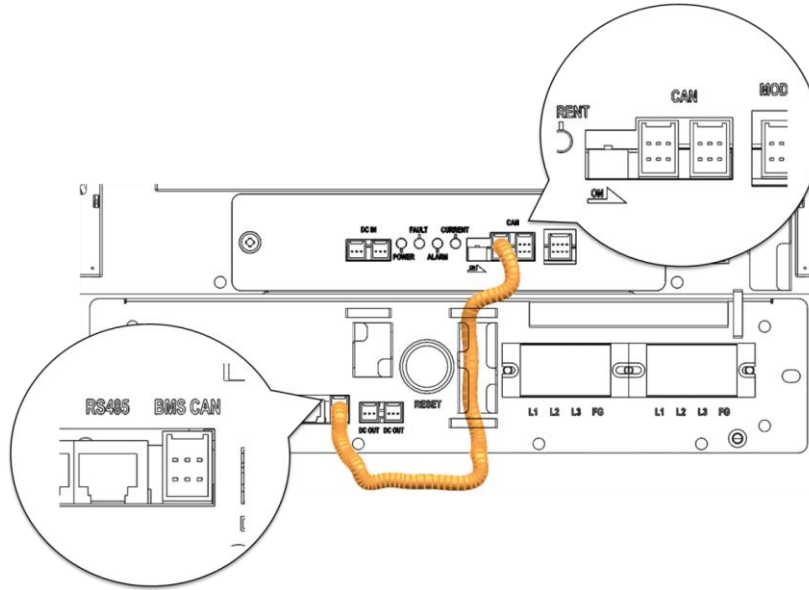

Figure 5-82: BMS CAN Cable from SMPS Assembly to SMU

17. Connect the TCP/IP Cable.

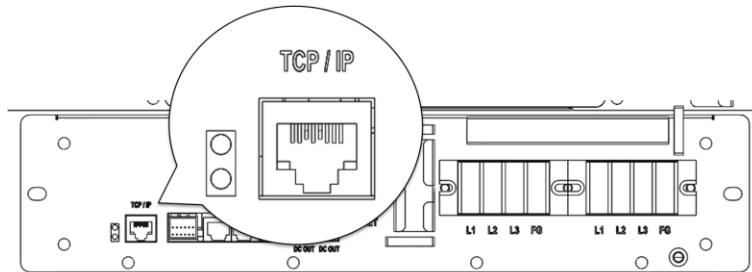

Figure 5-83: TCP/IP Cable

18. Connect the dry contact cable.

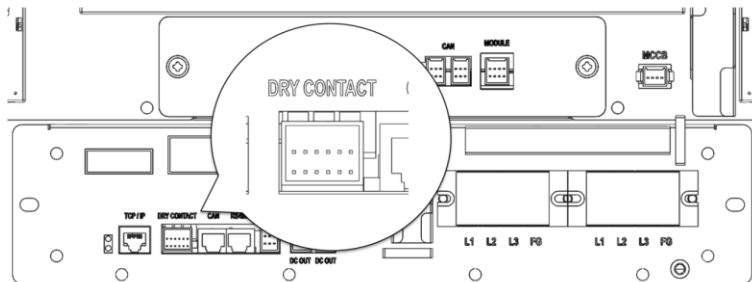

Figure 5-84: Dry Contact Cable

19. Remove the protective covers from the AC input terminals.

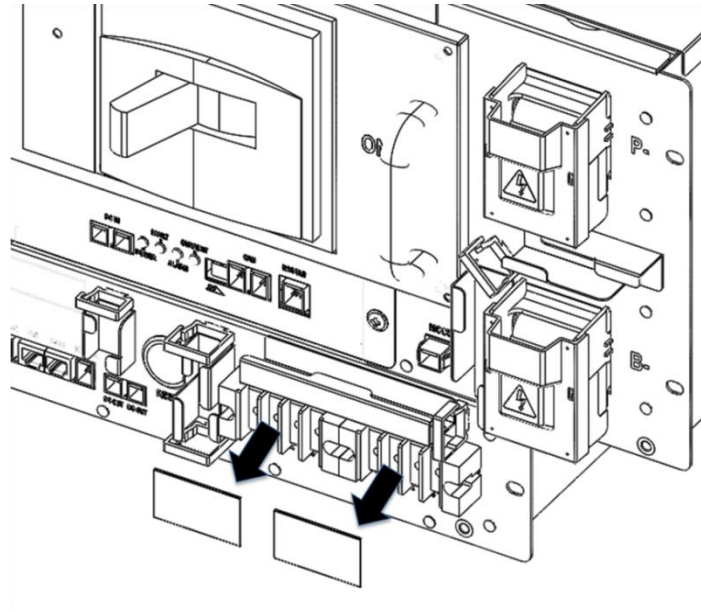

Figure 5-85: AC Input Terminals

20. Connect each AC input in the SMPS Assembly. Make sure the AC cables are not energized.<sup>1</sup>

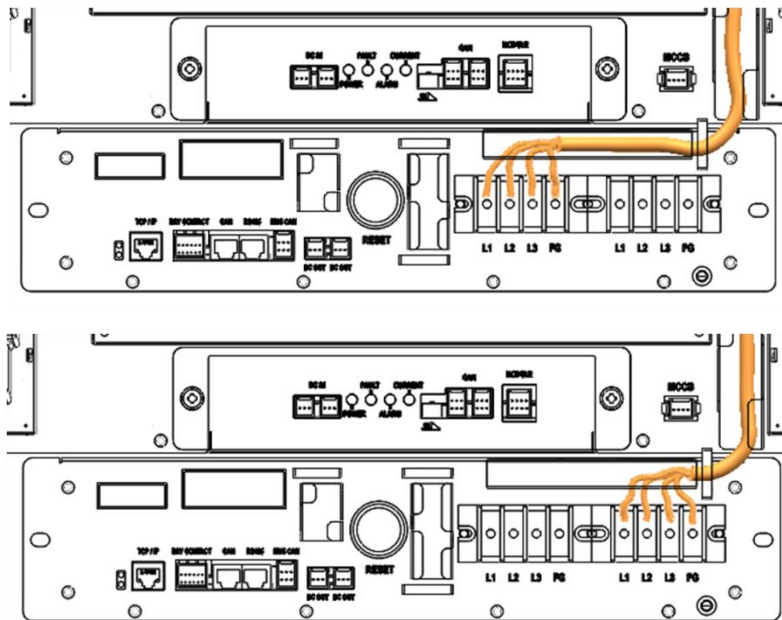

Figure 5-86: AC Input Terminals with Cables Attached

21. Reattach the protective covers to the AC input terminals.

<sup>1</sup> AC cables are not provided. They must be provided by the installer or customer.

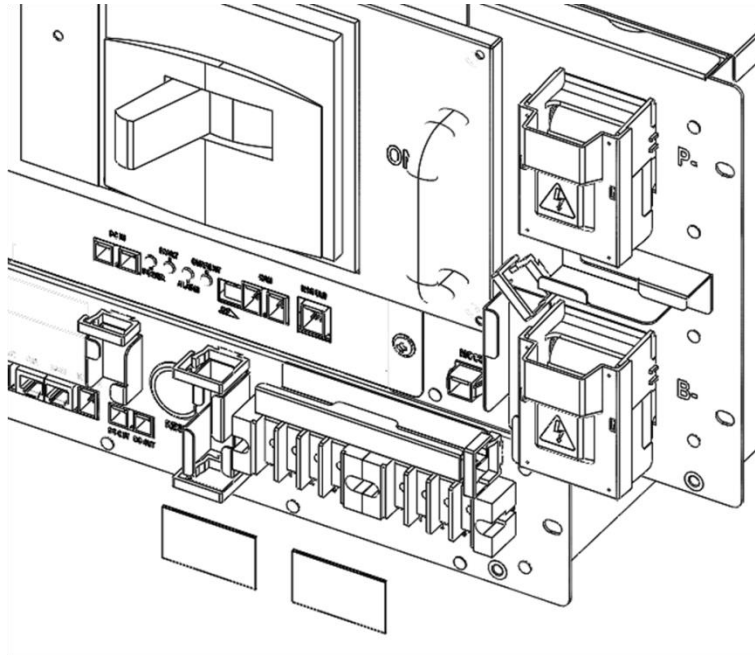

Figure 5-87: AC Input Terminals Protective Cover

22. Turn on the AC input to the SMPS Assembly.
23. Check the indicator LED and make sure it is in normal status.
24. Turn the MCCB handle to the "ON" position.

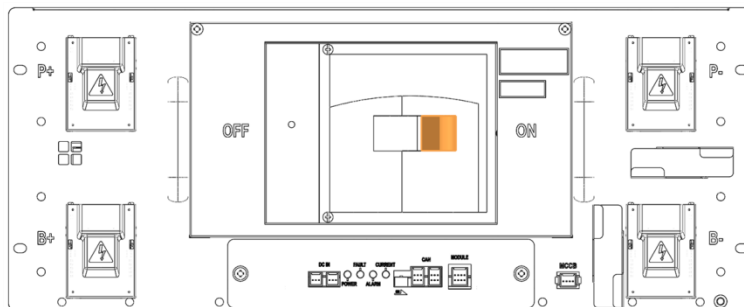



Figure 5-88: MCCB Handle in "ON" Position

25. For SMPS Assembly Type A, the System BMS inside the replacement SMU must be configured according to the battery system configuration. Refer to the installation manual for details.

### 5.3.6 Module BMS Replacement

	<b>CAUTION</b>
	<ul style="list-style-type: none"><li>▪ Follow the instructions exactly to protect the Module BMS and Battery Module from damage.</li><li>▪ DO NOT deviate from the sequence of the steps below.</li><li>▪ The voltage of the connected system increases proportionally as battery modules are connected. Exercise extreme caution to prevent the terminals from touching anything other than their intended mounting points.</li><li>▪ Exercise extreme caution to prevent terminals and wires from contacting a wire or terminal with the opposite polarity.</li><li>▪ Do not permit either battery terminal to contact the rack frame because it is possible to contact a connection with the opposite polarity.</li></ul>

1. Remove the wire harnesses that are connected to the signal connectors.
2. Remove the front cover of the battery module
3. Disconnect the voltage and temperature sensing connectors.

4. Remove the two screws on the Module BMS
5. Lift the Module BMS from the battery module.

	<p><b>NOTICE</b></p> <ul style="list-style-type: none"><li>▪ Four hooking points hold the Module BMS in place. Use care when removing and installing the Module BMS to prevent the hooks from damage.</li></ul>
---	---

6. Reverse the steps above to replace the Module BMS.

## **6. Appendix**

### **6.1 Disposal and Recycling**

For recycling, contact the manufacturer.

Contaminated packaging must be disposed in accordance with local regulations.









[www.SamsungSDI.com](http://www.SamsungSDI.com)