

Eaton® 9155 UPS

8–15 kVA
User's Guide



p/n: 164201553
Revision H0

Class A EMC Statements

FCC Part 15

NOTE  This equipment has been tested and found to comply with the limits for a Class A digital device, pursuant to part 15 of the FCC Rules. These limits are designed to provide reasonable protection against harmful interference when the equipment is operated in a commercial environment. This equipment generates, uses, and can radiate radio frequency energy and, if not installed and used in accordance with the instruction manual, may cause harmful interference to radio communications. Operation of this equipment in a residential area is likely to cause harmful interference in which case the user will be required to correct the interference at his own expense.

ICES-003

This Class A Interference Causing Equipment meets all requirements of the Canadian Interference Causing Equipment Regulations ICES 003.

Cet appareil numérique de la classe A respect et outes les exigences du Reglement sur le matériel brouilleur du Canada.

IEC 62040-2

Some configurations are classified under IEC 62040-2 as “C2 UPS for Unrestricted Sales Distribution.”

VCCI Notice

この装置は、情報処理装置等電波障害自主規制協議会（VCCI）の基準に基づくクラスA情報技術装置です。この装置を家庭環境で使用すると電波妨害を引き起こすことがあります。この場合には使用者が適切な対策を講ずるよう要求されることがあります。



IMPORTANT

To ensure you have the most up-to-date content and information for this product, please review the latest manual revision on our website, www.eaton.com/9155.

Eaton reserves the right to change specifications without prior notice. Modbus is a registered trademark of Schneider Automation, Inc. MOXA is a registered trademark and MGate is a trademark of MOXA, Inc. Spiralock is a registered trademark of Spiralock Corporation. KIRK is a registered trademark of Kirk Key Interlock company, LLC, a subsidiary of Halma plc. National Electrical Code and NEC are registered trademarks of National Fire Protection Association, Inc. ERIFLEX and FLEXIBAR are registered trademark of Erico International Corporation. All other trademarks are property of their respective companies.

©Copyright 2004-2019 Eaton, Raleigh, NC, USA. All rights reserved. No part of this document may be reproduced in any way without the express written approval of Eaton.

Table of Contents

1 Introduction	1
1.1 Options and Accessories	2
1.1.1 Maintenance Bypass Module (MBM)	2
1.1.2 Power Distribution Module (PDM)	2
1.1.3 Bypass Power Module	2
1.1.4 Parallel Tie Cabinet	2
1.1.5 Input Isolation Transformer	2
1.1.6 Seismic Kit	2
1.2 Using This Manual	3
1.3 Conventions Used in This Manual	3
1.4 Symbols, Controls, and Indicators	4
1.5 For More Information	4
1.6 Getting Help	5
1.7 Equipment Registration	5
2 Safety Warnings	7
2.1 Consignes de Sécurité	8
2.1.1 CONSIGNES DE SÉCURITÉ IMPORTANTES CONSERVER CES INSTRUCTIONS	8
2.2 Advertencias de Seguridad	9
2.2.1 INSTRUCCIONES DE SEGURIDAD IMPORTANTES GUARDE ESTAS INSTRUCCIONES	9
3 UPS Installation Plan and Unpacking	11
3.1 Creating an Installation Plan	11
3.2 Preparing the Site	11
3.2.1 Environmental and Installation Considerations	11
3.3 UPS System Power Wiring Preparation	23
3.4 Inspecting and Unpacking the Equipment	26
4 UPS System Installation	27
4.1 Preliminary Installation Information	27
4.2 Unloading the UPS Cabinet from the Pallet	27
4.3 External AC Power Wiring Installation	30
4.3.1 Selecting an Installation Option	30
4.3.2 UPS Only Installation	31
4.3.3 Input Isolation Transformer Installation	33
4.3.4 UPS-Mounted Bypass Switch Installation	35
4.3.4.1 MBM/PDM Setup	36
4.3.4.2 Wiring the MBM/PDM	38
4.3.5 Bypass Power Module Installation	42
4.4 Stabilizing the Cabinet	43
4.5 Internal Battery Tray Wiring Connections	45

Table of Contents

4.6 Extended Battery Module Installation.....	49
5 UPS Wiring Diagrams and Schematics	53
6 Communication	59
6.1 Installing Communication Options and Control Terminals	59
6.2 Communication Options	62
6.2.1 DB-9 Communication Port	62
6.2.2 X-Slot Cards.....	63
6.2.3 Power Management Software.....	64
6.3 Control Terminals	64
6.3.1 Remote Emergency Power-off	64
6.3.2 Relay Output Contacts.....	65
6.3.3 Programmable Signal Inputs.....	65
7 UPS Operating Instructions	67
7.1 Control Panel Functions	67
7.1.1 Changing the Language.....	68
7.1.2 Display Functions	68
7.1.3 User Settings.....	68
7.2 Initial UPS Startup.....	70
7.2.1 Normal Mode Startup	71
7.2.2 Starting the UPS on Battery	71
7.2.3 Internal Bypass Startup	72
7.2.4 Maintenance Bypass Startup.....	73
7.3 UPS Shutdown	73
7.4 UPS Bypass Operation.....	73
7.4.1 Transfer the load from the UPS to maintenance bypass	75
7.4.2 Transfer the load from maintenance bypass to the UPS	76
7.5 Configuring the UPS for EBMs	76
8 UPS Maintenance.....	79
8.1 UPS and Battery Care	79
8.2 Storing the UPS and Batteries	79
8.3 When to Replace Batteries	79
8.4 Recycling the Used Battery or UPS.....	79
9 Troubleshooting	81
9.1 Typical Alarms and Conditions	81
9.2 Silencing the Alarm	82
10 Product Specifications.....	83
11 Warranty.....	89

List of Figures

Figure 1.	The Eaton 9155 UPS and EBM (2-High Cabinets Shown)	1
Figure 2.	UPS Cabinet Dimensions (2-High Front and Right Side Views)	14
Figure 3.	Extended Battery Module Dimensions (2-High Front and Right Side Views)	15
Figure 4.	UPS Cabinet Dimensions (3-High Front and Right Side Views)	16
Figure 5.	Extended Battery Module Dimensions (3-High Front and Right Side Views)	17
Figure 6.	UPS Cabinet Dimensions (2 or 3-High Top and Bottom Views)	18
Figure 7.	Extended Battery Module Dimensions (2 or 3-High Top and Bottom Views).....	19
Figure 8.	2-High UPS Cabinet Center of Gravity	20
Figure 9.	2-High EBM Cabinet Center of Gravity	21
Figure 10.	3-High UPS Cabinet Center of Gravity	22
Figure 11.	3-High EBM Cabinet Center of Gravity	23
Figure 12.	Removing the Stabilizing Bracket Bolts	28
Figure 13.	Removing the Brackets and Shipping Pad.....	29
Figure 14.	Unloading the Cabinet	30
Figure 15.	Removing the Pallet.....	30
Figure 16.	UPS Rear View	32
Figure 17.	UPS Terminal Block	33
Figure 18.	UPS with Input Isolation Transformer Rear View	34
Figure 19.	Input Isolation Transformer Hardwiring	35
Figure 20.	UPS Rear View (2-High Cabinet Shown)	36
Figure 21.	Attaching the L-Brackets.....	37
Figure 22.	Installing the MBM or PDM	37
Figure 23.	Securing the MBM or PDM	38
Figure 24.	UPS with MBM Rear View	39
Figure 25.	MBM/PDM Hardwiring.....	40
Figure 26.	Wiring from Maintenance Bypass Switch to UPS	41
Figure 27.	Bypass Power Module Dimensions.....	42
Figure 28.	Lowering the Leveling Feet	43
Figure 29.	Stabilizing Bracket with One Cabinet	44
Figure 30.	Stabilizing Bracket with Two Cabinets	44
Figure 31.	Stabilizing Bracket with Three Cabinets.....	45
Figure 32.	Removing the Front Covers	46
Figure 33.	Battery Panel (Dead Front)	47
Figure 34.	Internal Battery Tray Wiring Connections.....	48
Figure 35.	Internal Battery Tray Wiring Diagram	49
Figure 36.	Typical EBM Installation (2-High Cabinets Shown)	50
Figure 37.	Front Ground Strap Installation (2-High Cabinets Shown)	51
Figure 38.	UPS Only Wiring Diagram	53
Figure 39.	UPS with Input Isolation Transformer Wiring Diagram	54

List of Figures

Figure 40.	UPS with Input Isolation Transformer and MBM/PDM Wiring Diagram	55
Figure 41.	UPS with MBM Wiring Diagram	56
Figure 42.	UPS with PDM Wiring Diagram	57
Figure 43.	Communication Options and Control Terminals	59
Figure 44.	Removing the Front Covers	60
Figure 45.	Installing Communication Cables	60
Figure 46.	Removing Knockout Tabs	61
Figure 47.	Reinstalling the Front Covers	61
Figure 48.	Communication Port	62
Figure 49.	Optional X-Slot Cards	63
Figure 50.	External Control Terminal Connections	64
Figure 51.	Eaton 9155 Control Panel	67
Figure 52.	Maintenance Bypass Switch	74
Figure 53.	Typical Hardwired Installation with UPS-Mounted Bypass Switch	75

List of Tables

Table 1.	Air Conditioning or Ventilation Requirements During Full Load Operation.....	12
Table 2.	UPS Cabinet Weights	13
Table 3.	UPS Cabinet Clearances	13
Table 4.	UPS Terminal Block (TB1) Wiring	24
Table 5.	Input Isolation Transformer Terminal Block Wiring	25
Table 6.	MBM/PDM Terminal Block (TB10) Wiring	25
Table 7.	Communication Port Pin Assignment.....	62
Table 8.	Programmable Signal Inputs	66
Table 9.	Menu Map for Display Functions	68
Table 10.	User Settings.....	69
Table 11.	UPS-Mounted Bypass Switch Positions.....	74
Table 12.	Troubleshooting Guide.....	81
Table 13.	Model List.....	83
Table 14.	Dimensions and Weights	83
Table 15.	Environmental and Safety Specifications	84
Table 16.	Technical Specifications	84
Table 17.	Model Specifications	85
Table 18.	Battery Specifications.....	87
Table 19.	Battery Runtimes (in Minutes) at Full Load.....	87

List of Tables

Chapter 1 Introduction

The Eaton® 9155 is a double-conversion, split-phase, online uninterruptible power supply (UPS) for protecting computer systems and other intelligent devices. It is ideal for protecting essential information technology and electrical engineering infrastructure in corporate, telecom, health care, banking, and industrial applications.

The UPS provides a steady, well-regulated power supply for your computing and communications equipment, while protecting it from the frequent irregularities that are inherent in commercially available power. Voltage spikes, power surges, brownouts, and power failures have the potential to corrupt critical data, destroy unsaved work sessions, and in some instances, damage expensive hardware.

With the Eaton 9155, you can safely eliminate the effects of electrical line disturbances and guard the integrity of your systems and equipment. [Figure 1](#) shows the Eaton 9155 UPS and an optional Extended Battery Module (EBM).

Figure 1. The Eaton 9155 UPS and EBM (2-High Cabinets Shown)

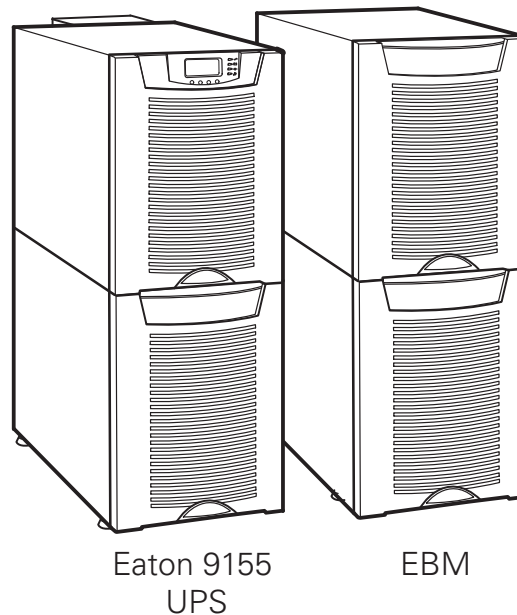

Providing outstanding performance and reliability, the Eaton 9155's unique benefits including the following:

- Online UPS design with pure sine wave output. The UPS filters and regulates incoming AC power and provides consistent power to your equipment without draining the battery.
- More wattage in less space with a 0.9 power factor—protecting more equipment and leaving more room for expansion.
- Support for Powerware Hot Sync® paralleling of multiple modules for redundancy or extra capacity.
- Input current total harmonic distortion (THD) of less than five percent, using active input power factor correction.
- ABM® technology that uses advanced battery management to increase battery service life, optimize recharge time, and provide a warning before the end of useful battery life.

- Start-on-battery capability for powering up the UPS even if utility power is not available.
- Up to four hours of extended runtime with added EBMs.
- Emergency shutdown control through the remote emergency power-off (REPO) port.
- Standard communication options with a DB-9 serial port, relay output contacts, and programmable signal inputs.
- Optional X-Slot® cards with enhanced communication capabilities for increased power protection and control.
- Advanced power management with the Software Suite CD for graceful shutdowns and power monitoring.
- Backed by worldwide agency approvals.

1.1 Options and Accessories

The following options for the Eaton 9155 are available:

1.1.1 Maintenance Bypass Module (MBM)

The optional MBM is installed on the UPS rear panel and is used to bypass the UPS during maintenance or servicing. The maintenance bypass switch on the MBM provides a Make-Before-Break (MBB) wrap-around bypass for UPS service without shutting down the load.

1.1.2 Power Distribution Module (PDM)

The optional PDM provides the same functionality as the MBM and also comes equipped with several different types of output receptacles.

1.1.3 Bypass Power Module

The Eaton Bypass Power Module (BPM) is designed to be a maintenance bypass switch that also contains flexible output power distribution and mounting options.

The BPM provides added reliability to Eaton uninterruptible power supply (UPS) systems by ensuring seamless, uninterrupted, no-break transfer as well as a lock-out/tag-out (LOTO) feature to ensure the greatest safety for UPS technicians and electricians. The BPM also offers output distribution in order to simplify wiring in a rackmount IT environment, potentially removing the need for a panelboard, breakers, and conduit for distribution.

1.1.4 Parallel Tie Cabinet

An optional parallel system with up to three UPSs can be installed to provide a parallel capacity and/or redundant system. This load sharing system provides more capacity than a single UPS and can provide backup, depending on the load and configuration. In addition, when one UPS is taken out of service for maintenance or is not operating properly, a redundant UPS continues to supply uninterrupted power to the critical load. A parallel Powerware Hot Sync Controller Area Network (CAN) Bridge Card provides connectivity for system metering and operational mode control. The parallel system consists of two to three UPSs, each with a parallel CAN Bridge Card, and a parallel tie cabinet.

Refer to the *Eaton 9155 Parallel UPS (8–15 kVA) User's Guide* for more information.

1.1.5 Input Isolation Transformer

The optional input isolation transformer is located at the bottom of a 3-high UPS model. The input isolation transformer provides a neutral from a 208V or 240V input source with 240V output and can be wired to the UPS or to an MBM/PDM.

1.1.6 Seismic Kit

The optional seismic kit secures the UPS and optional EBMs for Zone 4 seismic installations.

1.2 Using This Manual

This manual describes how to install and operate the Eaton 9155 UPS. Read and understand the procedures described in this manual to ensure trouble-free installation and operation. In particular, be thoroughly familiar with the REPO procedure or the LOAD OFF procedure, see **Chapter 7 UPS Operating Instructions**.

The information in this manual is divided into sections and chapters. The system, options, and accessories being installed dictate which parts of this manual should be read. At a minimum, **Chapter 1 Introduction** through **Chapter 4 UPS System Installation** and **Chapter 7 UPS Operating Instructions** should be examined.

Read through each procedure before beginning the work. Perform only those procedures that apply to the UPS system being installed or operated.

1.3 Conventions Used in This Manual

This manual uses these type conventions:

- **Bold type** highlights important concepts in discussions, key terms in procedures, and menu options, or represents a command or option that you type or enter at a prompt.
- *Italic type* highlights notes and new terms where they are defined.
- `Screen type` represents information that appears on the screen or LCD.

Icon	Description
Note	Information notes call attention to important features or instructions.
[Keys]	Brackets are used when referring to a specific key, such as [Enter] or [Ctrl].

In this manual, the term UPS refers only to the UPS cabinet and its internal elements. The term UPS system refers to the entire power protection system – the UPS cabinet, an external battery system, and options or accessories installed.

The term line-up-and-match refers to accessory cabinets that are physically located adjacent to the UPS. The term standalone refers to accessory cabinets that are located separate from the UPS.

Left and right side notations are referenced standing in front of the cabinet.

1.4 Symbols, Controls, and Indicators

The following are examples of symbols used on the product to alert you to important information:



RISK OF ELECTRIC SHOCK - Observe the warning associated with the risk of electric shock symbol.



CAUTION: REFER TO OPERATOR'S MANUAL - Refer to your operator's manual for additional information, such as important operating and maintenance instructions.



This symbol indicates that you should not discard the product in the trash. This product must be disposed of properly. For more information, contact your local recycling/reuse or hazardous waste center.



This symbol indicates that you should not discard waste electrical or electronic equipment (WEEE) in the trash. For proper disposal, contact your local recycling/reuse or hazardous waste center.



ON - Indicates that the switch is in the ON position.



OFF - Indicates that the switch is in the OFF position.



PHASE - The word "phase."

1.5 For More Information

Refer to the **Eaton 9155 Parallel UPS 8-15 kVA User's Guide** for the following additional information:

- Installation instructions, including site preparation, planning for installation, wiring and safety information, and detailed illustrations of cabinets with dimensional and connection point drawings
- Operation, including breakers, standard features and optional accessories, procedures for using the bypass functions, and information about maintenance

Refer to the **Eaton Bypass Power Module (BPM) User's Guide** for the following additional information:

- Installation instructions, including site preparation, planning for installation, wiring and safety information, and detailed illustrations of cabinets with dimensional and connection point drawings
- Operation, including breakers, standard features and optional accessories, procedures for using the bypass functions, and information about maintenance

Refer to the **Eaton Remote Monitoring Device (RMD) Installation and Operation Manual** for additional installation and operating instructions.

- Visit www.eaton.com/powerquality or contact an Eaton service representative for information on how to obtain copies of these manuals.

1.6 Getting Help

If help is needed with any of the following:

- Scheduling initial startup
- Regional locations and telephone numbers
- A question about any of the information in this manual
- A question this manual does not answer

Please call the Customer Reliability Center at:

United States: **1-800-843-9433**
Canada: **1-800-461-9166 ext 260**
All other countries: **Call your local service representative**

Please have the following information ready when you call for service:

- Model number
- Serial number
- Firmware version number
- Date of failure or problem
- Symptoms of failure or problem
- Customer return address and contact information

Please use the following e-mail address for manual comments, suggestions, or to report an error in this manual:

E-ESSDocumentation@eaton.com

1.7 Equipment Registration

Please visit www.eaton.com/pg/register to register your new Eaton UPS / Eaton UPS Accessory.

Model Number:

Serial Number:

Chapter 2 Safety Warnings

IMPORTANT SAFETY INSTRUCTIONS SAVE THESE INSTRUCTIONS

This manual contains important instructions that you should follow during installation and maintenance of the UPS and batteries. Please read all instructions before operating the equipment and save this manual for future reference.

DANGER

This UPS contains LETHAL VOLTAGES. All repairs and service should be performed by AUTHORIZED SERVICE PERSONNEL ONLY. There are NO USER SERVICEABLE PARTS inside the UPS.

WARNING

- This UPS contains its own energy source (batteries). The UPS output may carry live voltage even when the UPS is not connected to an AC supply.
 - To reduce the risk of fire or electric shock, install this UPS in a temperature and humidity controlled, indoor environment, free of conductive contaminants. Ambient temperature must not exceed 40°C (104°F). Do not operate near water or excessive humidity (95% maximum).
 - To reduce the risk of fire, connect only to a circuit provided with 100 amperes maximum branch circuit overcurrent protection in accordance with the National Electrical Code® (NEC®), ANSI/NFPA 70.
 - Output overcurrent protection and disconnect switch must be provided by others.
-

CAUTION

- Batteries can present a risk of electrical shock or burn from high short circuit current. Observe proper precautions. Servicing should be performed by qualified service personnel knowledgeable of batteries and required precautions. Keep unauthorized personnel away from batteries.
 - Proper disposal of batteries is required. Refer to your local codes for disposal requirements.
 - Never dispose of batteries in a fire. Batteries may explode when exposed to flame.
-

2.1 Consignes de Sécurité

2.1.1 CONSIGNES DE SÉCURITÉ IMPORTANTES CONSERVER CES INSTRUCTIONS



IMPORTANT

Cet manuel comporte des instructions importantes que vous êtes invité à suivre lors de toute procédure d'installation et de maintenance des batteries et de l'onduleur. Veuillez consulter entièrement ces instructions avant de faire fonctionner l'équipement et conserver ce manuel afin de pouvoir vous y reporter ultérieurement.



DANGER!

Cet onduleur contient des TENSIONS MORTELLES. Toute opération d'entretien et de réparation doit être EXCLUSIVEMENT CONFIEE A UN PERSONNEL QUALIFIE AGRÉÉ. AUCUNE PIÈCE RÉPARABLE PAR L'UTILISATEUR ne se trouve dans l'onduleur.



AVERTISSEMENT!

- Cet onduleur renferme sa propre source d'énergie (batteries). Les prises de sortie peuvent être sous tension même lorsque l'onduleur n'est pas branché sur le secteur.
 - Pour réduire les risques d'incendie et de décharge électrique, installer l'onduleur uniquement à l'intérieur, dans un lieu dépourvu de matériaux conducteurs, où la température et l'humidité ambiantes sont contrôlées. La température ambiante ne doit pas dépasser 40 °C. Ne pas utiliser à proximité d'eau ou dans une atmosphère excessivement humide (95 % maximum).
 - La protection contre une surintensité pour le(s) circuit(s) de sortie de courant alternatif doit être fournie par un autre fournisseur.
 - Les interrupteurs de déconnexion convenables pour le(s) circuit(s) de sortie de courant alternatif doivent être fournis par un autre fournisseur.
-



ATTENTION!

- Les batteries peuvent présenter un risque de décharge électrique ou de brûlure par des courts-circuits de haute intensité. Prendre les précautions nécessaires.
 - Une mise au rebut réglementaire des batteries est obligatoire. Consulter les règlements en vigueur dans votre localité.
 - Ne jamais jeter les batteries au feu. L'exposition aux flammes risque de les faire exploser.
-

2.2 Advertencias de Seguridad

2.2.1 INSTRUCCIONES DE SEGURIDAD IMPORTANTES GUARDE ESTAS INSTRUCCIONES



IMPORTANT

Este manual contiene instrucciones importantes que debe seguir durante la instalación y el mantenimiento del SIE y de las baterías. Por favor, lea todas las instrucciones antes de poner en funcionamiento el equipo y guarde este manual para referencia en el futuro.



PELIGRO

Este SIE contiene VOLTAJES MORTALES. Todas las reparaciones y el servicio técnico deben ser efectuados SOLAMENTE POR PERSONAL DE SERVICIO TÉCNICO AUTORIZADO. No hay NINGUNA PARTE QUE EL USUARIO PUEDA REPARAR dentro del SIE.



WARNING

- Este SIE contiene su propia fuente de energía (las baterías). Los receptáculos de salida pueden transmitir corriente eléctrica aun cuando el SIE no esté conectado a un suministro de corriente alterna (c.a.).
- Para reducir el riesgo de incendio o de choque eléctrico, instale este SIE en un lugar cubierto, con temperatura y humedad controladas, libre de contaminantes conductores. La temperatura ambiente no debe exceder los 40°C. No trabaje cerca del agua o con humedad excesiva (95% máximo).
- La protección contra exceso de corriente para el/los circuito(s) de CA de salida será suministrada por terceros.
- Los interruptores de desconexión debidamente clasificados para el/los circuito(s) de CA de salida serán suministrados por terceros.



PRECAUCIÓN

- Las baterías pueden presentar un riesgo de descargas eléctricas o de quemaduras debido a la alta corriente de cortocircuito. Preste atención a las instrucciones correspondientes.
- Es necesario desechar las baterías de un modo adecuado. Consulte las normas locales para conocer los requisitos pertinentes.
- Nunca deseche las baterías en el fuego. Las baterías pueden explotar si se las expone a la llama.

Safety Warnings

Chapter 3 UPS Installation Plan and Unpacking

Use the following basic sequence of steps to install the UPS:

1. Create an installation plan for the UPS system.
2. Prepare your site for the UPS system.
3. Inspect and unpack the UPS cabinet.
4. Unload and install the UPS cabinet, and wire the system.
5. Complete the Installation Checklist.
6. Have authorized service personnel perform preliminary operational checks and start up the system.

The instructions are intended for the chief operator/system supervisor, electrical consultants, and installation electricians. Local regulations and electrical code must be followed during the UPS installation.

3.1 Creating an Installation Plan

Before installing the UPS system, read and understand how this manual applies to the system being installed. Use this chapter's procedures and illustrations and those in **Chapter 4 UPS System Installation** to create a logical plan for installing the system.

3.2 Preparing the Site

For the UPS system to operate at peak efficiency, the installation site should meet the environmental parameters outlined in this manual. The operating environment must meet the weight, clearance, and environmental requirements specified.

3.2.1 Environmental and Installation Considerations

The UPS system installation must meet the following guidelines:

- The system must be installed on a level floor suitable for computer or electronic equipment.
- The system must be operated at an altitude no higher than 1500m (5000 ft) without derating. For additional assistance with high altitude operation, contact an Eaton service representative (see paragraph [1.6 Getting Help](#)).
- The system must be installed in a temperature and humidity controlled indoor area free of conductive contaminants.



CAUTION

Do not expose the UPS to overly aggressive environments, like salt mist or corrosive gases. High relative humidity accelerates the effects of contaminants. The UPS should be installed in a G1 environment (based on ANSI/ISA S-71.04 classifications). If the UPS is used in a more aggressive environment, it can cause reduced product life and possibly early failure. If the installation location does not meet the recommended environment, contact Eaton service representative for further information (see paragraph [1.6 Getting Help](#)).

- The environmental requirements specified below are for the air at the intake ports of the 9155 UPS, and are the maximum, not to exceed, ratings.
 - There shall be at least a 1.8°F (1.0°C) difference between the dry bulb temperature and the wet bulb temperature, at all times, to maintain a non-condensing environment.
 - The maximum rate of temperature change shall be limited to 3°F over 5 minutes (36°F/hour), based on the ASHRAE Standard 90.1-2013.

- The newer, more energy efficient data center cooling methods (such as air side economization) can create much wider ranges of temperature and Relative Humidity (RH) in the UPS room and/or data center. There are two aspects of this increased operating environment that can, if ignored, create issues.
 - One is the creation of microclimates, which are persistent variations of temperature and/or RH within a single room. For example one side of the room is always cooler than the other side, no matter the actual temperature.
 - The other aspect is the rate of change of temperature and/or RH, which can occur during transitions within the cooling system. Examples: changing the mixture ratio of inside versus outside air, or external changes in the outside air when going from night to day, and back to night.
 - When ignored, either one of these aspects can create an undesirable microclimate at the UPS location. If the environment created by this microclimate exceeds the UPS operating specification, the UPS reliability, over time, will be reduced. These same environmental extremes will also create reliability concerns for any servers that are exposed to them.

Failure to follow guidelines may void your warranty.

The basic environmental requirements for operation of the UPS are:

- Ambient Temperature Range: 5–40°C (41–104°F)
- Recommended Operating Range: 5–40°C (41–104°F)
- Maximum Relative Humidity: 5–95%, noncondensing

 **CAUTION**

If battery systems are located in the same room as the UPS, the battery manufacturer's environmental requirements should be followed if they are more stringent than the UPS requirements. Operating temperatures above the recommended range will result in decreased battery life and performance, and may reduce or void the battery warranty.

The UPS ventilation requirements are shown in [Table 1](#). To allow for future power upgrades, Eaton recommends using air conditioning or ventilation sized for the fully rated UPS kVA installed instead of the derated kVA ordered. Sizing the site cooling infrastructure to be capable of cooling the maximum kVA size will allow a full power rating upgrade without having to modify the infrastructure.

Table 1. Air Conditioning or Ventilation Requirements During Full Load Operation

Model	UPS Rating	Minimum Required Cooling Air Flow
Eaton 9155 UPS	8–15 kVA	129 liter/sec (274 cfm)

The UPS equipment operating environment must meet the weight requirements shown in [Table 2](#) and the size requirements shown in [Table 3](#).

When planning the installation, consider the UPS weight for floor loading. The strength of the installation surface must be adequate for point and distributed loadings. The approximate weights are shown in the following table.

Table 2. UPS Cabinet Weights

Standard Model Floor Loadings (2-High/3-High Cabinets)			
Eaton 9155	Maximum Weight (lb)	Point Loading (lb/in²)	Distributed Loading (lb/ft²)
2-High UPS	352	88	166
3-High UPS	590	148	278
2-High UPS with Maintenance Bypass Module (MBM) or Power Distribution Module (PDM)			
3-High UPS with MBM/PDM			
3-High UPS with Isolation Transformer	558	140	263
2-High EBM	480	120	226
3-High EBM	710	178	335

The UPS cabinet uses forced air cooling to regulate internal component temperature. Allow clearance in front of and in back of the cabinet for proper air circulation. The clearances required around the UPS cabinet are shown in the following table.

Table 3. UPS Cabinet Clearances

From Front of Cabinet	36" (91.4 cm) working space
From Back of Cabinet	6" (15.2 cm) without an MBM/PDM installed; with an MBM/PDM installed, clearance is determined by the customer-supplied mating

Figure 2. UPS Cabinet Dimensions (2-High Front and Right Side Views)

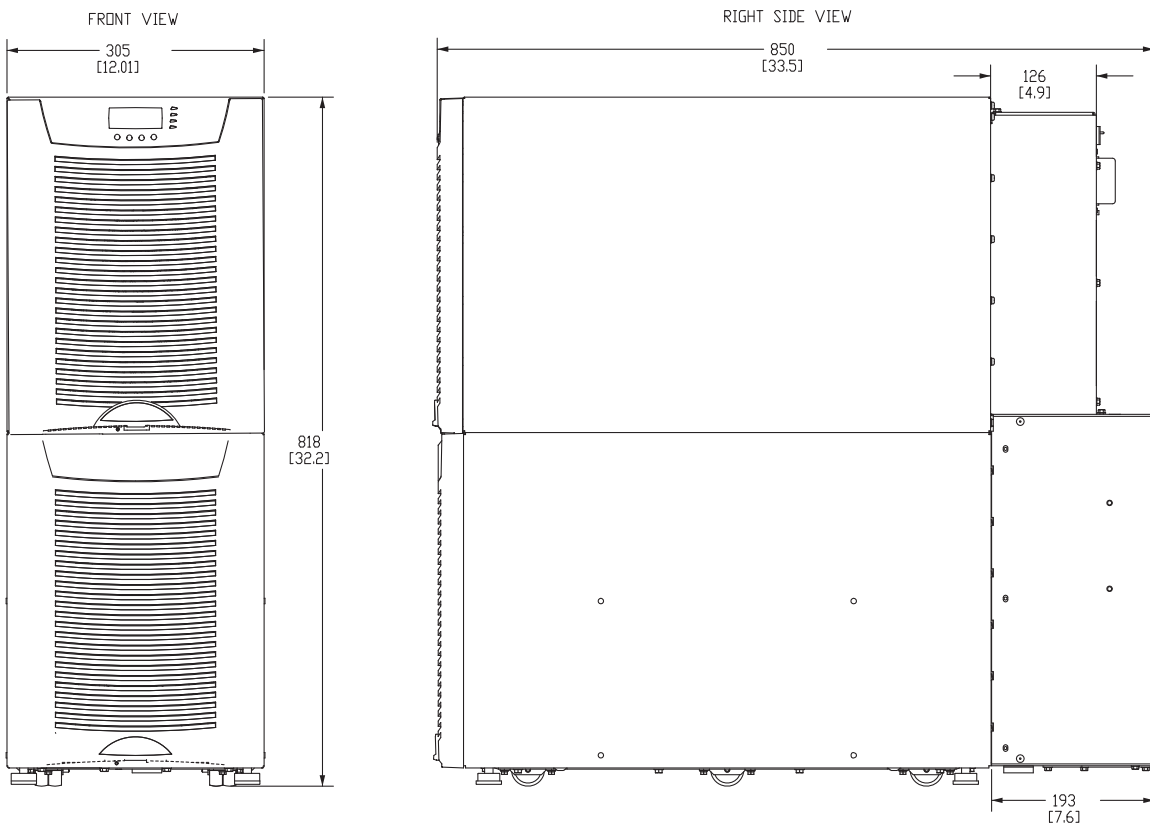

Dimensions are in millimeters [inches]

Figure 3. Extended Battery Module Dimensions (2-High Front and Right Side Views)

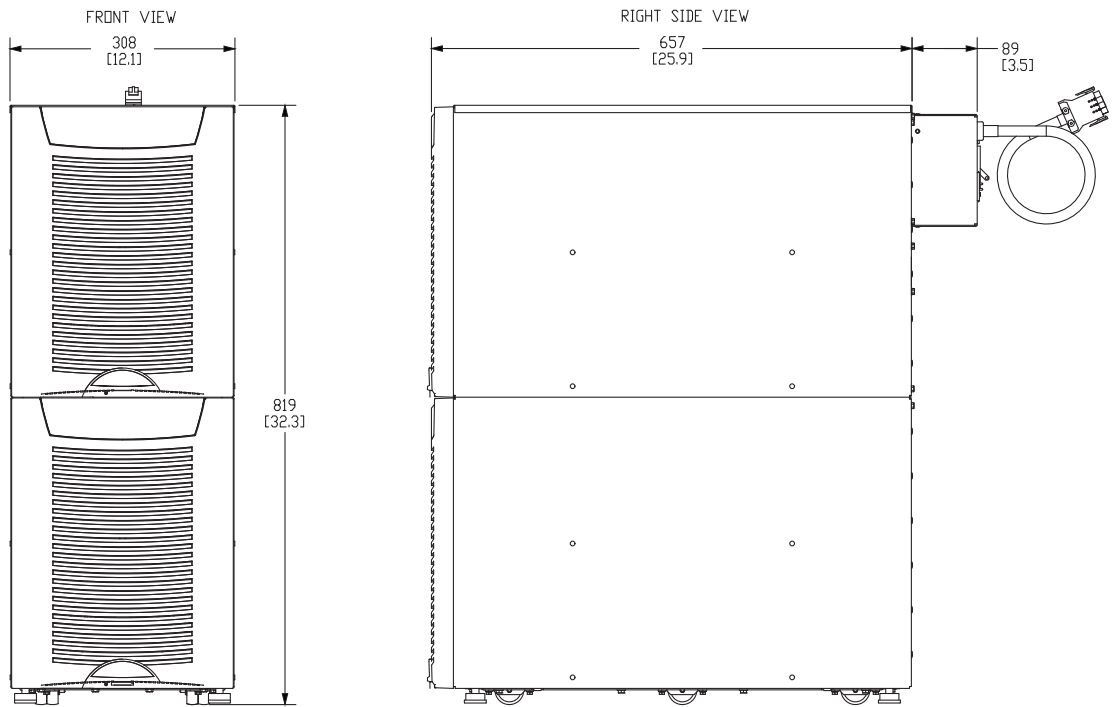

Dimensions are in millimeters [inches]

Figure 4. UPS Cabinet Dimensions (3-High Front and Right Side Views)

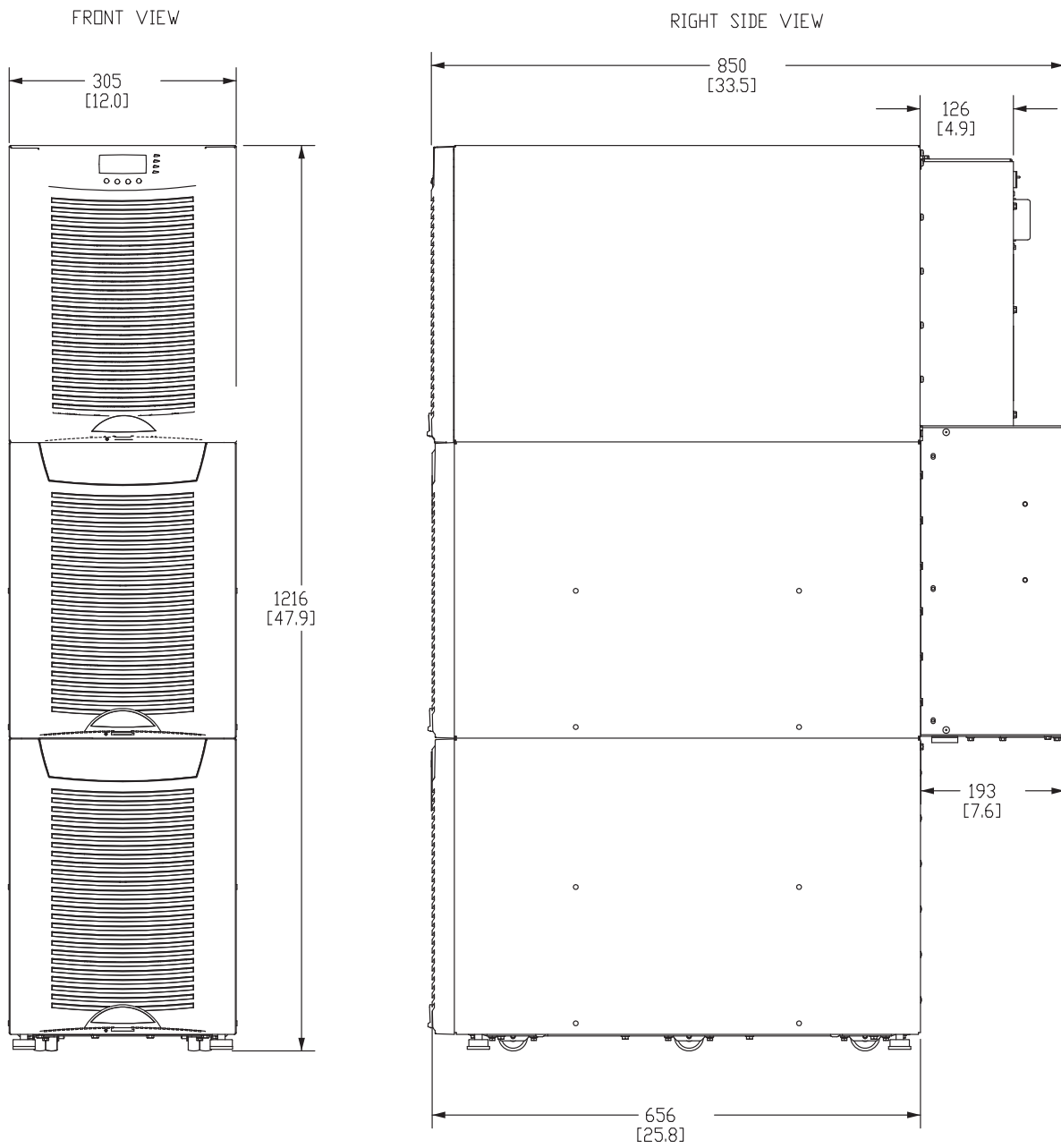

Dimensions are in millimeters (inches)

Figure 5. Extended Battery Module Dimensions (3-High Front and Right Side Views)

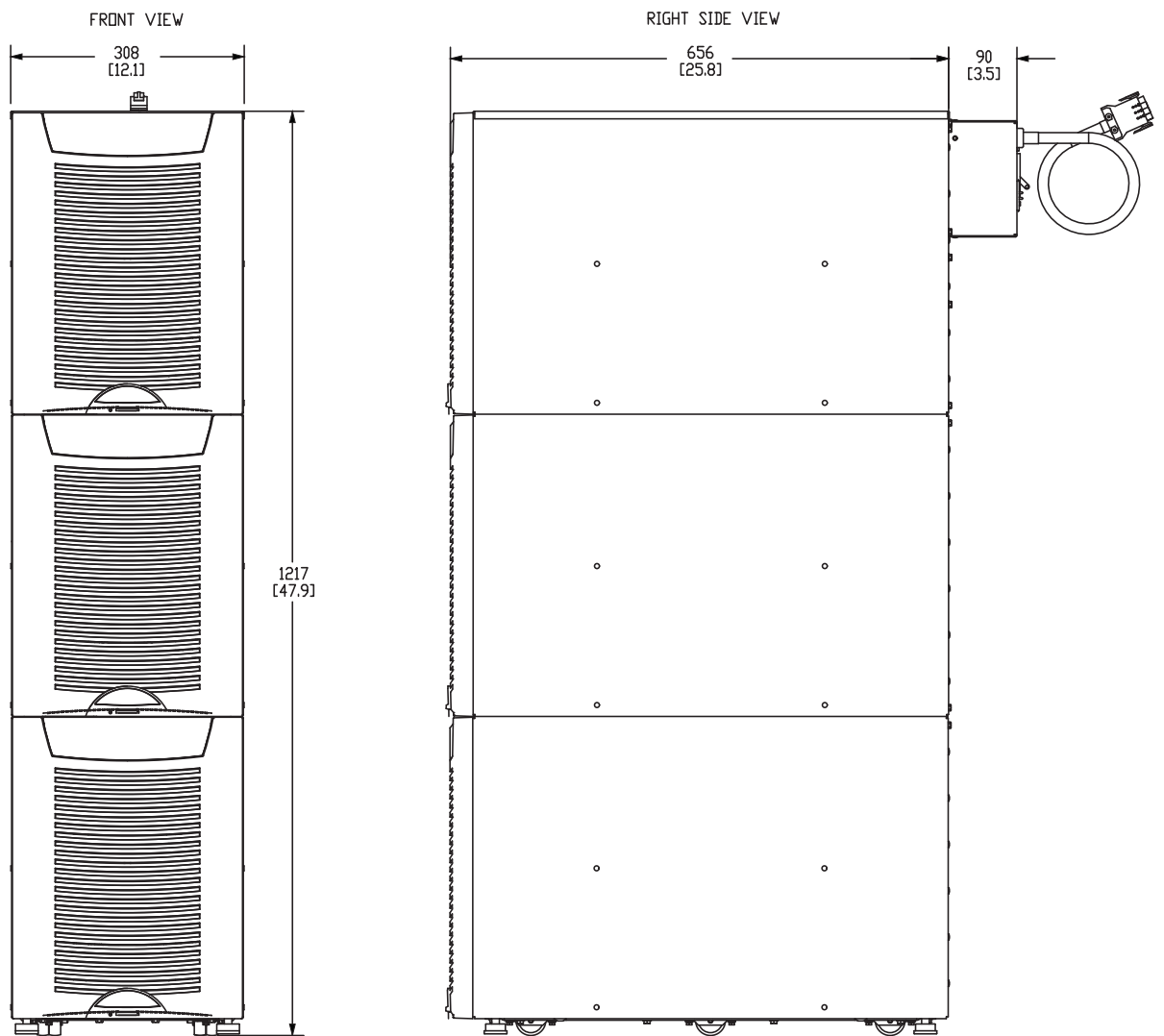

Dimensions are in millimeters [inches]

Figure 6. UPS Cabinet Dimensions (2 or 3-High Top and Bottom Views)

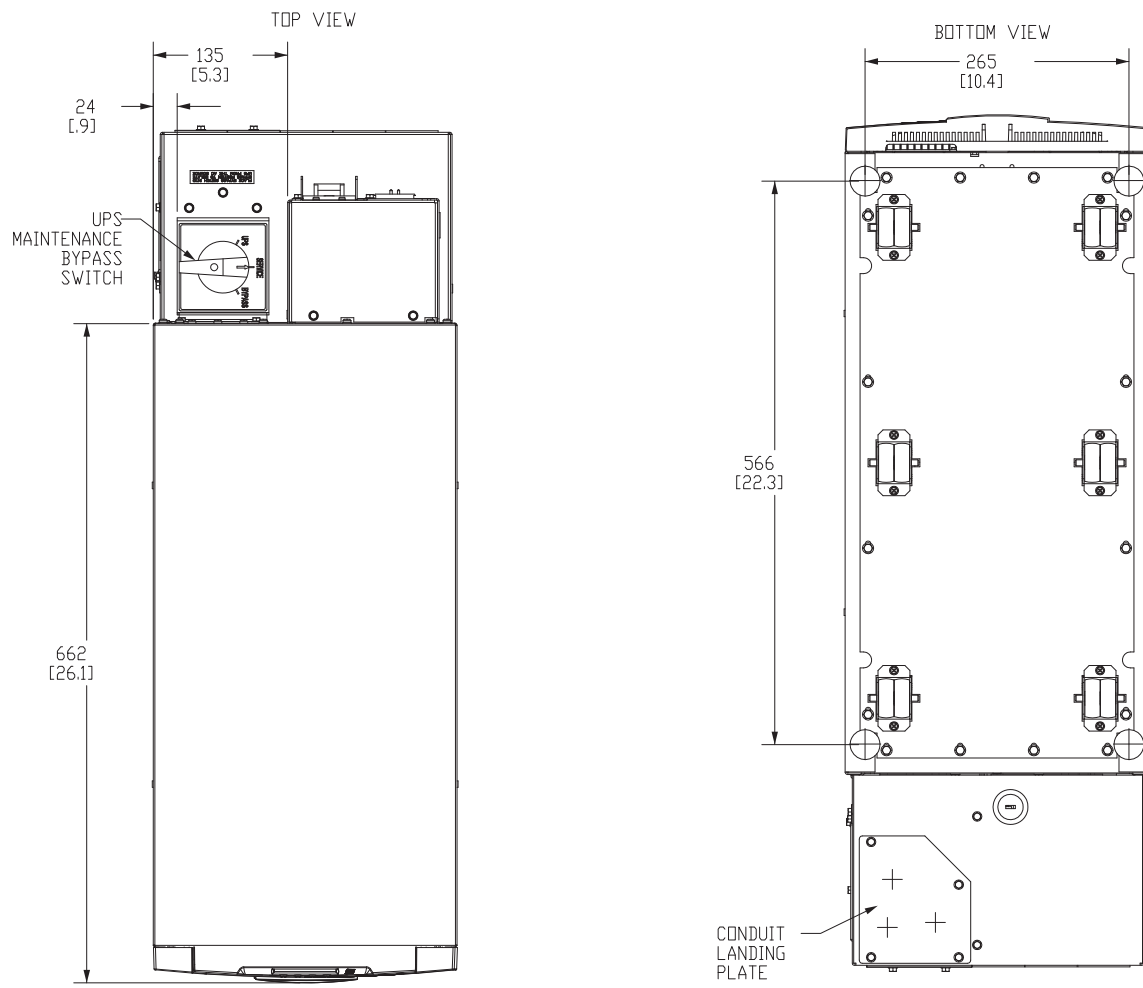

Dimensions are in millimeters [inches]

Figure 7. Extended Battery Module Dimensions (2 or 3-High Top and Bottom Views)

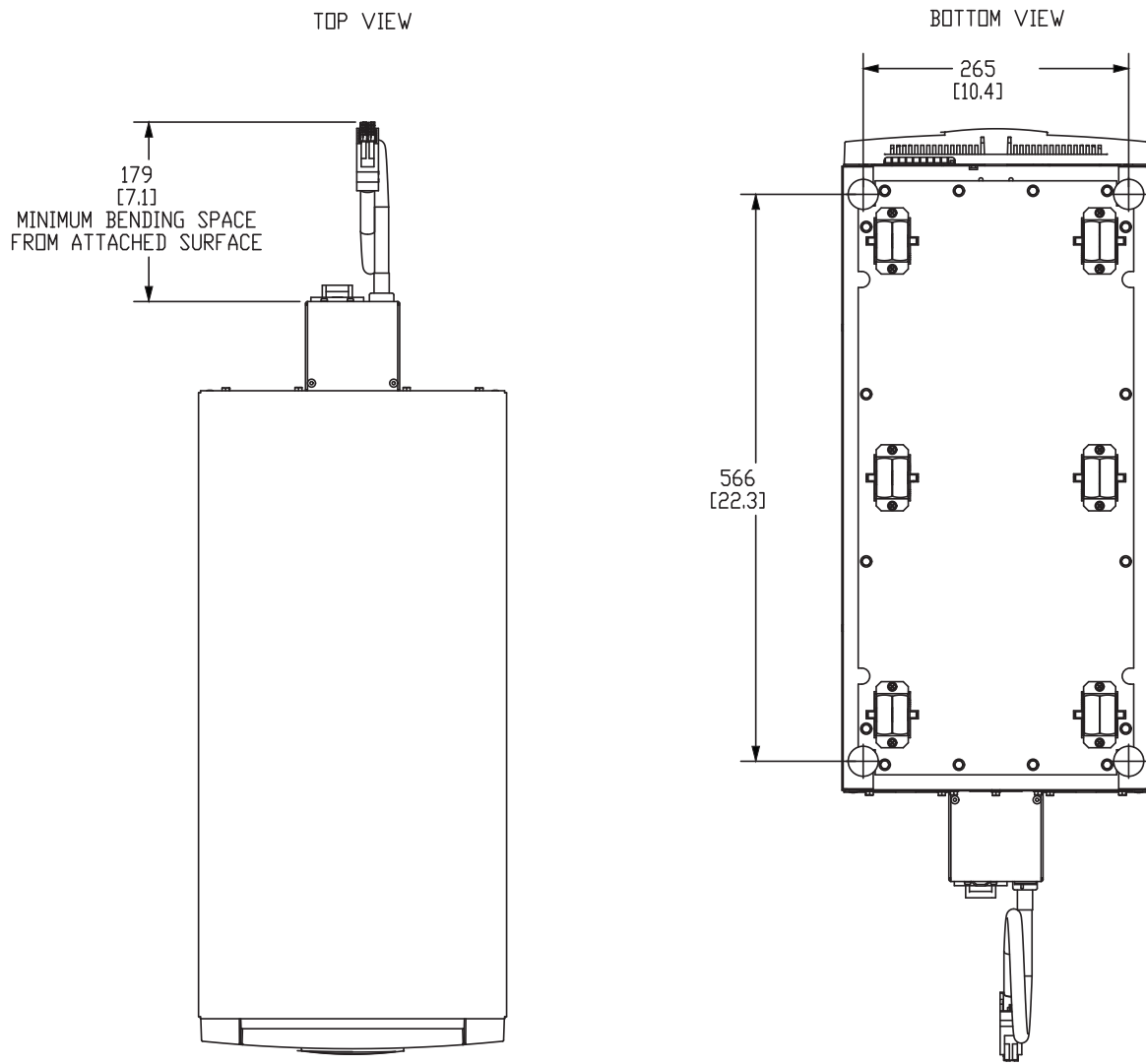

Dimensions are in millimeters [inches]

Figure 8. 2-High UPS Cabinet Center of Gravity

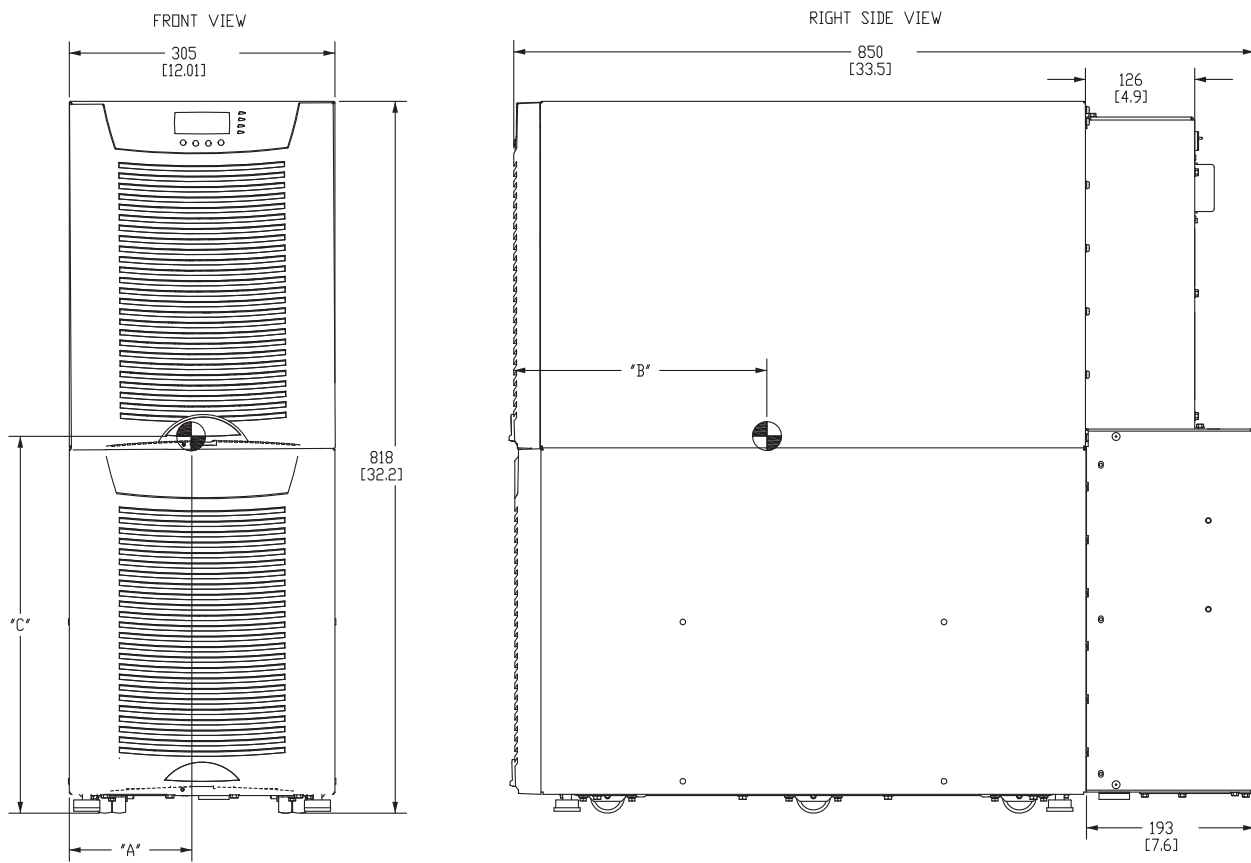

Dimensions are in millimeters [inches]

Weight and Center of Gravity	Dimensions mm [in] See Figure 8 .			Weight kg [lb]
	A	B	C	
Eaton 9155 8-15 kVA UPS 2-High	81 [3.2]	452 [17.8]	406 [16.0]	169 [373]

Figure 9. 2-High EBM Cabinet Center of Gravity

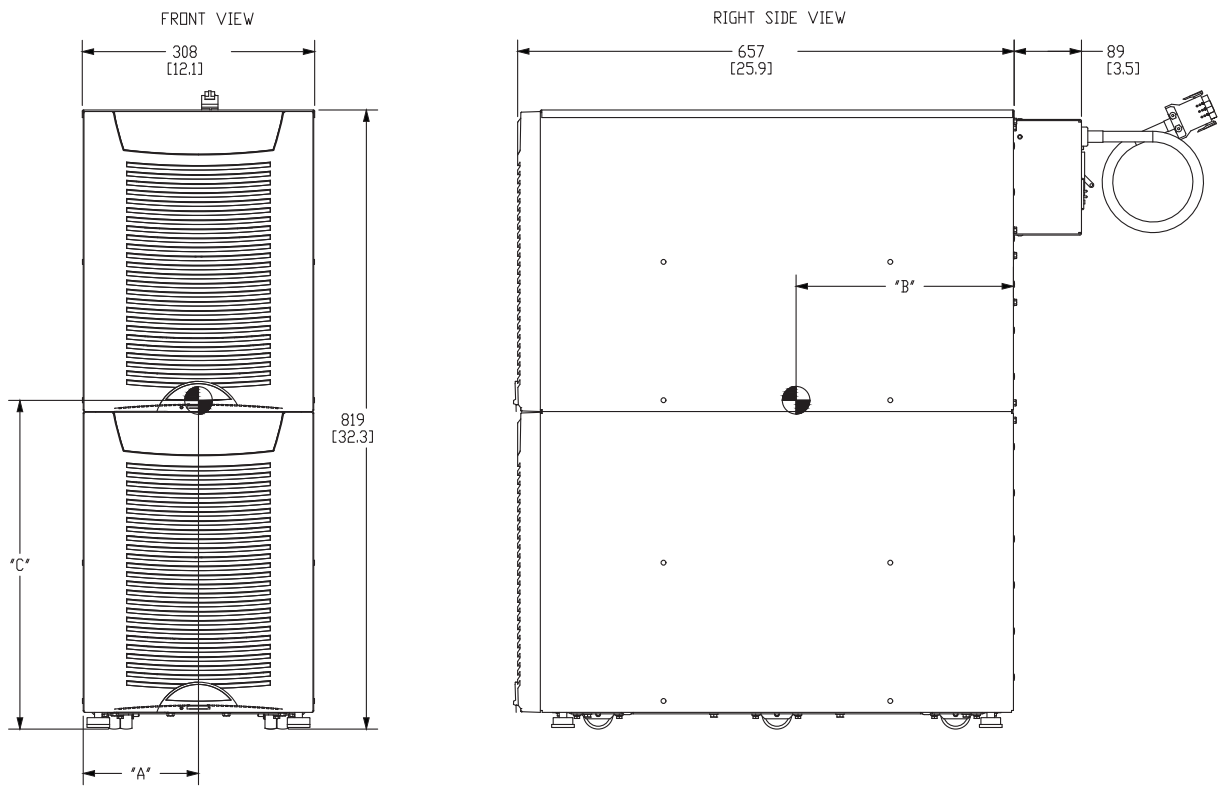

Dimensions are in millimeters [inches]

Weight and Center of Gravity	Dimensions mm [in] See Figure 9 .			Weight kg [lb]
	A	B	C	
Eaton 9155 Extended Battery Module 2-High	81 [3.2]	452 [17.8]	406 [16.0]	218 [480]

Figure 10. 3-High UPS Cabinet Center of Gravity

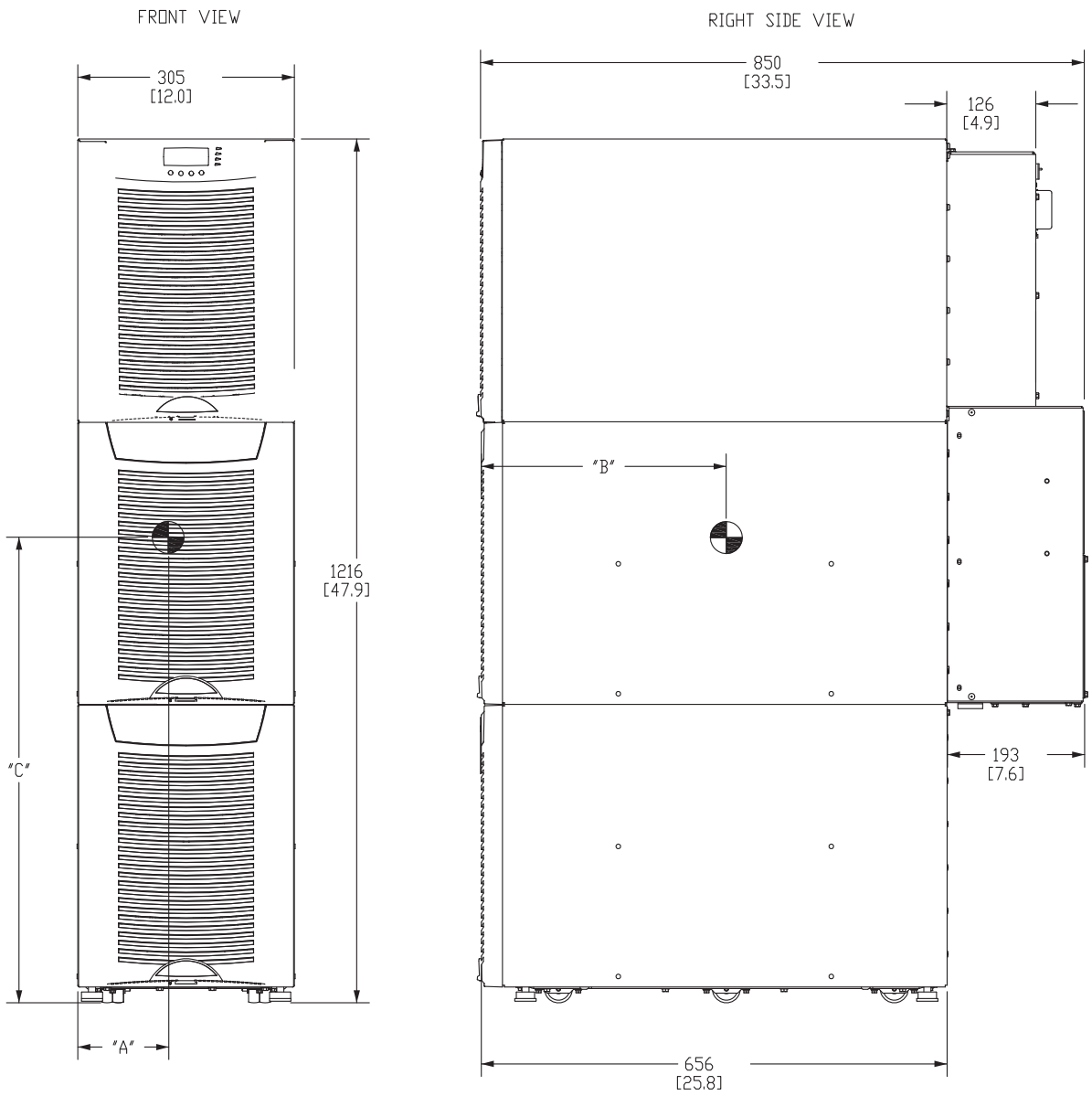

Dimensions are in millimeters [inches]

Weight and Center of Gravity	Dimensions mm [in] See Figure 10 .			Weight kg [lb]
	A	B	C	
Eaton 9155 8–15 kVA UPS 3-High	81 [3.2]	452 [17.8]	610 [24.0]	276 [609]

Figure 11. 3-High EBM Cabinet Center of Gravity

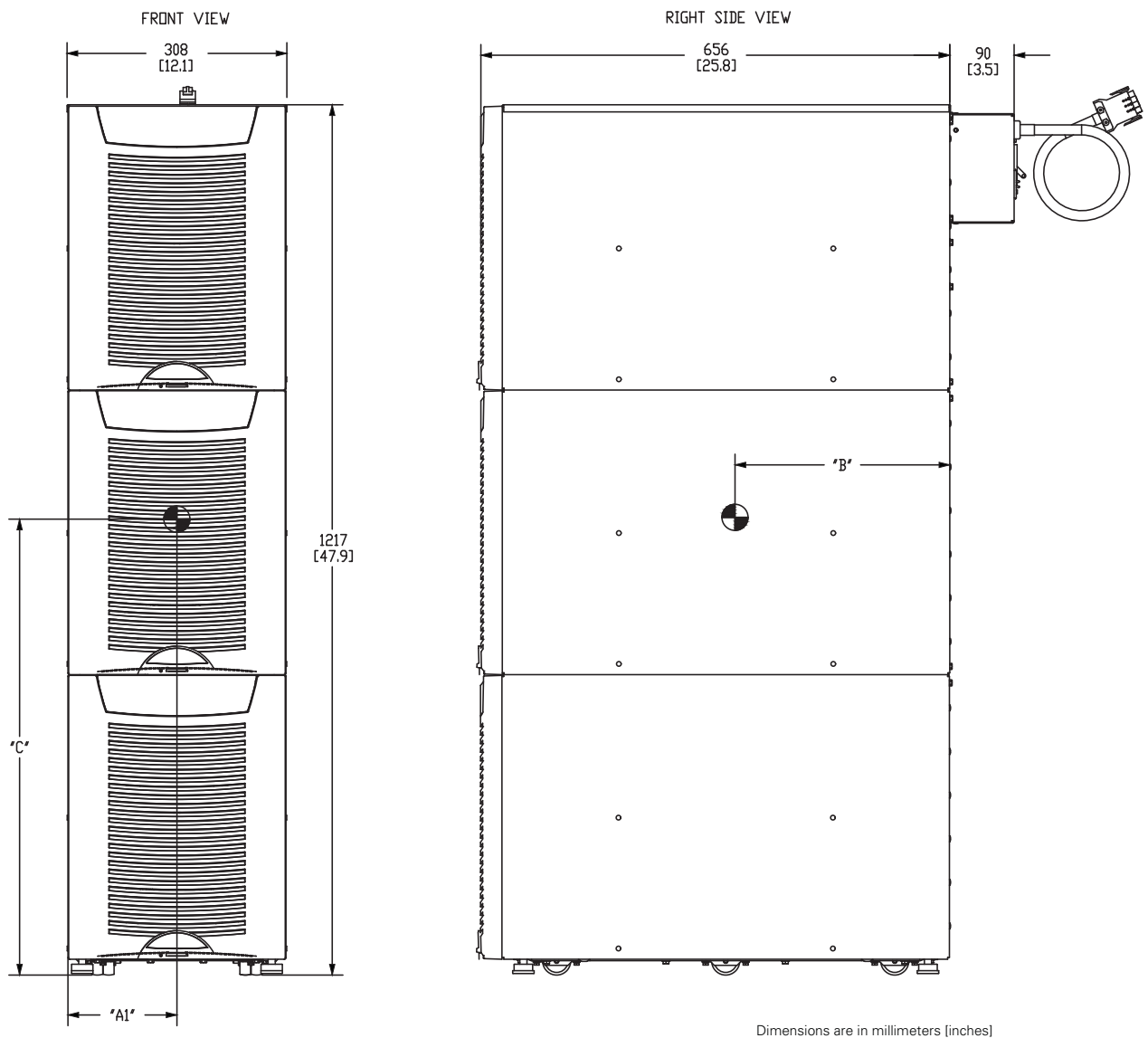

Weight and Center of Gravity	Dimensions mm [in] See Figure 11 .			Weight kg [lb]
	A	B	C	
Eaton 9155 Extended Battery Module 3-High	81 [3.2]	452 [17.8]	610 [24.0]	276 [609]

3.3 UPS System Power Wiring Preparation

Read and understand the following notes while planning and performing the installation:

 **WARNING**

As a result of the connected loads high leakage current is possible. Connection to earth ground is required for safety and proper product operation. Do not check UPS operation by any action that includes removal of the earth (ground) connection with loads attached.

- Refer to national and local electrical codes for acceptable external wiring practices.
- For external wiring, use 90°C copper wire.

 **IMPORTANT**

This product has been evaluated for use with **copper wire only**. For external wiring, use only 90°C copper wire.

Wire sizes listed in [Table 4](#) through [Table 6](#) are for copper wiring only. If wire is run in an ambient temperature greater than 40°C, larger size wire may be necessary. Wire sizes are based on using the specified breakers.

- Recommended wire sizes are based on NFPA National Electrical Code® (NEC®) 70 Table 310.15(B)(16) 90° C ampacity with 40°C ambient correction factors.
- Input neutral must be wired for proper operation. Failure to connect an input neutral will void the warranty. If the optional input transformer is installed, an input neutral is not required.
- The Eaton 9155 UPS is a single-feed UPS only.

Table 4. UPS Terminal Block (TB1) Wiring

Wire Function		Terminal Position	Input Circuit Breaker Rating		Minimum Wire Size*	Tightening Torque	Conduit Connection (Entry Size)
Input	Ground	TB1-1			8 AWG	25 lb in (2.83 Nm)	2" access hole for 1-1/2" conduit
	AUX	TB1-2-1 and 2-2			—		
	Not Used	TB1-2A-1 and 2A-2			—		
	L1	TB1-3	8 kVA	60A	4 AWG (21.2 mm ²)		
	Neutral	TB1-4	10 kVA	80A	3 AWG (26.7 mm ²)		
	L2	TB1-5	12 kVA	100A	2 AWG (33.6 mm ²)		
			15 kVA	110A	2 AWG (33.6 mm ²)		
Output	L1	TB1-6			8 AWG	25 lb in (2.83 Nm)	2" access hole for 1-1/2" conduit
	Neutral	TB1-7			8 AWG		
	L2	TB1-8			8 AWG		
	Not Used	TB1-8A-1 and 8A-2			—		
	Ground	TB1-9			8 AWG		

* Use only 75°C-rated copper wire. Minimum wire size is based on 120/208 full load ratings applied to NEC Code Table 310-16. Code may require a larger AWG size than shown in this table because of temperature, number of conductors in the conduit, or long service runs. Follow local requirements.

Table 5. Input Isolation Transformer Terminal Block Wiring

Wire Function		Terminal Position	Input Circuit Breaker Rating		Minimum Wire Size*	Tightening Torque
Input	L1	TB1-1	8 kVa	60A	3 AWG (26.7 mm ²)	25 lb in (2.83 Nm)
	L2 (208V)	TB1-2	10 kVA	80A	2 AWG (33.6 mm ²)	
	L2 (240V)	TB1-3	12 kVA	100A	1 AWG (42.4 mm ²)	
Output	L1	TB1-4	8 kVA		4 AWG (21.2 mm ²)	25 lb in (2.83 Nm)
	L2	TB1-5	10 kVA		3 AWG (26.7 mm ²)	
			12 kVA		2 AWG (33.6 mm ²)	
	Neutral	TB1-6	15 kVA		2 AWG (33.6 mm ²)	
Ground	Output	TB1-7			8 AWG	25 lb in (2.83 Nm)
	Input	TB1-8				

* Use only 75°C-rated copper wire. Minimum wire size is based on 120/208 full load ratings applied to NEC Code Table 310-16. Code may require a larger AWG size than shown in this table because of temperature, number of conductors in the conduit, or long service runs. Follow local requirements.

Table 6. MBM/PDM Terminal Block (TB10) Wiring

Wire Function		Input Circuit Breaker Rating		Minimum Wire Size*	Tightening Torque	Conduit Connection (Entry Size)
Input	Ground			8 AWG		
	L1	8 kVa	60A	4 AWG (21.2 mm ²)	120 lb in (13.5 Nm)	2" access hole for 1-1/2" conduit
	Neu- tral	10 kVA	80A	3 AWG (26.7 mm ²)		
		12 kVA	100A	2 AWG (33.6 mm ²)		
	L2	15 kVA	100A	2 AWG (33.6 mm ²)		
Output	L1			3 AWG	120 lb in (13.5 Nm)	2" access hole for 1-1/2" conduit
	Neu- tral			3 AWG		
	L2			3 AWG		
	Ground			8 AWG		

* Use only 75°C-rated copper wire. Minimum wire size is based on 120/208 full load ratings applied to NEC Code Table 310-16. Code may require a larger AWG size than shown in this table because of temperature, number of conductors in the conduit, or long service runs. Follow local requirements.

3.4 Inspecting and Unpacking the Equipment

The cabinet is shipped bolted to a metal and wood pallet with outer protective packaging material covering the cabinets.

1. Carefully inspect the outer packaging for evidence of damage during transit.

 **CAUTION**

Do not install a damaged cabinet. Report any damage to the carrier and contact an Eaton service representative immediately.



NOTE

Check the battery recharge date on the packaging label. If the date has expired and the batteries were never recharged, do not use the UPS. Contact your service representative.

2. Use a forklift or pallet jack to move the packaged cabinet to the installation site, or as close as possible, before unpacking. If possible, move the cabinet using the pallet. Insert the forklift or pallet jack forks between the supports on the bottom of the pallet.
3. Set the pallet on a firm, level surface, allowing a minimum clearance of 3m (10 ft) on each side for removing the cabinet from the pallet.
4. Remove the protective packaging material from the cabinet and recycle in a responsible manner. Retain any parts kits packaged with the cabinet.
5. Inspect the contents for any evidence of physical damage, and compare each item with the Bill of Lading. If damage has occurred or shortages are evident, contact an Eaton service representative immediately to determine the extent of the damage and its impact on further installation.

If any equipment has been damaged during shipment, keep the shipping and packing materials for the carrier or place of purchase and file a claim for shipping damage. If you discover damage after acceptance, file a claim for concealed damage.

To file a claim for shipping damage or concealed damage: 1) File with the carrier within 15 days of receipt of the equipment; 2) Send a copy of the damage claim within 15 days to your service representative.



NOTE

While waiting for installation, protect the unpacked cabinet from moisture, dust, and other harmful contaminants. Failure to store and protect the UPS properly may void the warranty.



NOTE

Check the battery recharge date on the packaging label. If the date has expired and the batteries were never recharged, do not use the UPS. Contact your service representative.

Chapter 4 UPS System Installation

4.1 Preliminary Installation Information

 **WARNING**

Installation should be performed only by qualified personnel.

Refer to the following while installing the UPS system:

- Review **Chapter 3 UPS Installation Plan and Unpacking**, for cabinet dimensions, equipment weight, wiring and terminal data, and installation notes.
- Do not tilt the cabinets more than $\pm 10^\circ$ during installation.
- Remove conduit landing plates to add conduit landing holes as required.
- If perforated floor tiles are required for ventilation, place them in front of the UPS.

4.2 Unloading the UPS Cabinet from the Pallet

The following tools are required for unloading the cabinet(s):

- 15 mm wrench or socket
- 7 mm nutdriver or socket

 **CAUTION**

The UPS and Extended Battery Module (EBM) are heavy (see). Unloading the cabinets requires at least two people to safely remove the cabinets from the pallet.

To remove the UPS or EBM from the shipping pallet:

1. Remove the two M10 bolts securing the stabilizing bracket to the pallet (see [Figure 12](#)).

Figure 12. Removing the Stabilizing Bracket Bolts

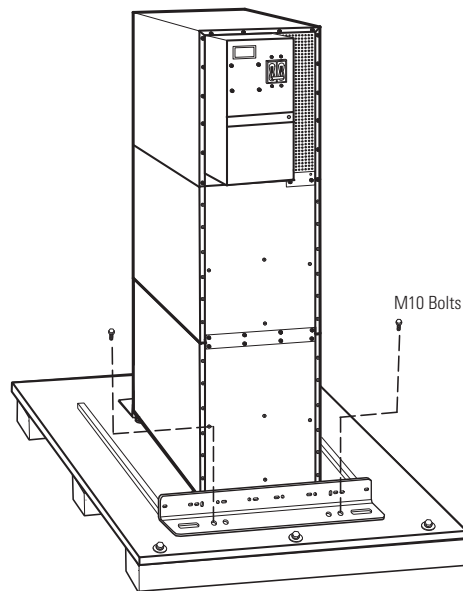

2. Remove the M10 bolts from the two Pallet Brackets securing the leveling feet to the pallet (see [Figure 13](#)).
3. Remove the four M4 screws securing the stabilizing bracket to the cabinet rear panel and remove the bracket (see [Figure 13](#)). Retain the hardware for later use.



NOTE

Be sure to retain the stabilizing bracket and hardware for later re-assembly onto the cabinet.

4. Remove the front cover from the bottom cabinet to access the front shipping bracket.
Press and release the handle latch at the bottom of the cover and then lift the cover up and off the cabinet.
5. Remove the three M10 bolts securing the rear shipping pad to the pallet and remove the shipping pad (see [Figure 13](#)).



NOTE

Hold the back of the cabinet so that the bolts can be removed easily without the cabinet rolling backward.

6. Remove the two M10 bolts securing the front shipping bracket and remove the bracket (see [Figure 13](#)).
If needed, adjust the leveling feet to release the bracket.

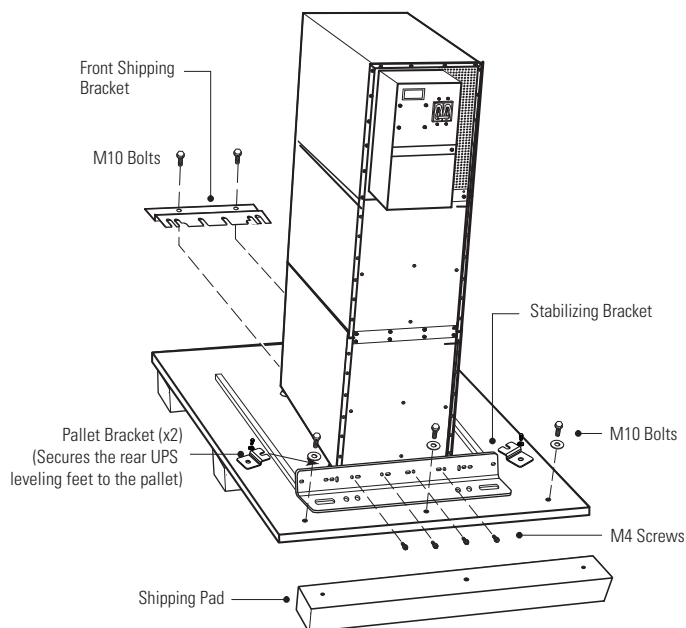
Figure 13. Removing the Brackets and Shipping Pad

7. Reinstall the front cover removed in [Step 4](#).

Hang the top edge of the cover on the cabinet first, then lower the bottom edge and snap into place.

**NOTE**

Be sure to support the front and back of the cabinet when rolling it off the pallet to prevent tipping.

8. Slowly roll the cabinet toward the rear of the pallet. Once the pallet tilts, continue rolling the cabinet down the pallet until the cabinet touches the floor (see [Figure 14](#)).

If needed, adjust the leveling feet so that the cabinet will roll.

Figure 14. Unloading the Cabinet

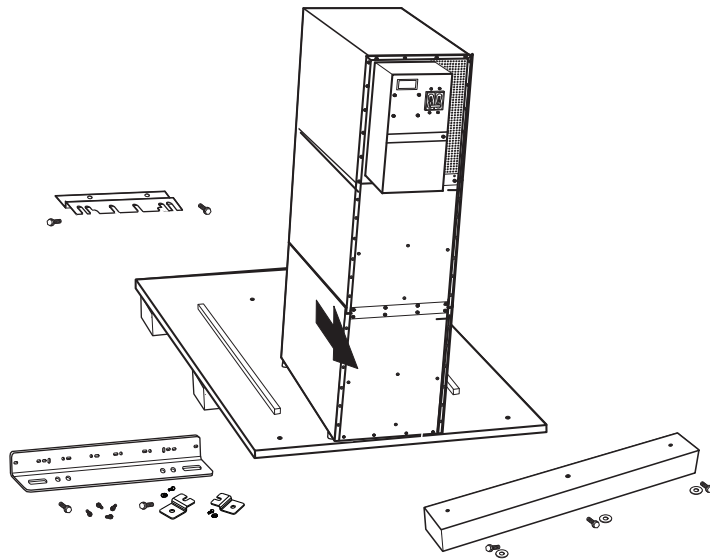

9. With the cabinet supported, slowly pull the pallet away from the cabinet (see [Figure 15](#)).

Figure 15. Removing the Pallet

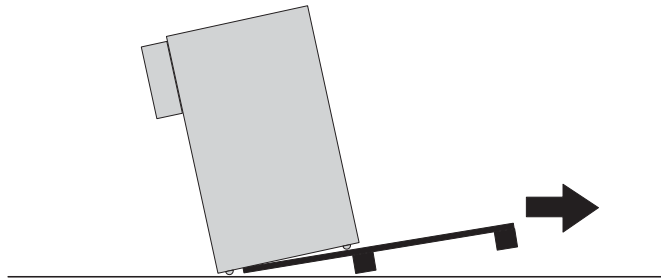

10. Roll the cabinet to the desired location.

4.3 External AC Power Wiring Installation

4.3.1 Selecting an Installation Option

You are now ready to install the Eaton 9155 UPS. Select one of the following installation options according to your UPS configuration:

UPS Configuration	Paragraph Section
UPS only	4.3.2 UPS Only Installation
UPS with an input isolation transformer	4.3.3 Input Isolation Transformer Installation
UPS with a UPS-Mounted Bypass Switch	4.3.4 UPS-Mounted Bypass Switch Installation
UPS with a Bypass Power Module (BPM)	Refer to the Eaton Bypass Power Module (BPM) User's Guide .
Parallel UPS configuration	Refer to the Eaton 9155 Parallel UPS (8-15 kVA) User's Guide .

4.3.2 UPS Only Installation

The Eaton 9155 has the following power connections:

- 2-phase (L1 and L2), neutral, and ground connection for rectifier/bypass input
- 2-phase (L1 and L2), neutral, and ground connection for load output

The nominal input/output voltages are:

- 100/200, 110/220, or 120/240 Vac with 180° phase displacement
- 120/208 or 127/220 Vac with 120° phase displacement

Output overcurrent protection and disconnect switch must be provided by others.

WARNING

Only qualified service personnel (such as a licensed electrician) should perform the UPS installation and initial startup. Risk of electrical shock.

To hardwire the UPS:

1. Verify that the electrical connections to the installation site have been properly installed.
2. A wall-mounted, user-supplied, readily-accessible disconnection device must be incorporated in the input wiring.

Compare the circuit breaker ratings and wire sizes to the specifications in [Table 4](#).



NOTE

To accommodate the feature of easy system expandability, it is recommended that initial installation of the Eaton 9155 UPS contain wiring to support the maximum capacity of the UPS cabinet.

3. Switch off utility power to the distribution point where the UPS will be connected. Be absolutely sure there is no power.
4. Determine your equipment's grounding requirements according to your local electrical code.
5. Verify that the UPS battery circuit breaker is in the OFF position (see [Figure 16](#)).

Figure 16. UPS Rear View

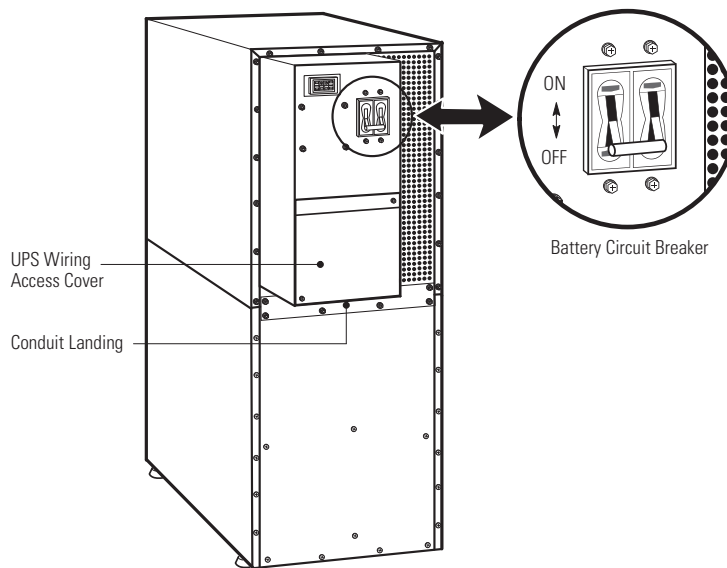

6. Remove the UPS wiring access cover and retain (see [Figure 16](#)).
7. Install conduit and hardwire the input, output, and ground terminations for the UPS.
See [Table 4](#) for specifications and [Figure 17](#) for a detailed view of the UPS terminal block.
8. Replace the UPS wiring access cover.
9. Continue to paragraph [4.4 Stabilizing the Cabinet](#) to complete the UPS installation.



NOTE

Input neutral must be wired for proper operation. Failure to connect an input neutral will void the warranty.

Figure 17. UPS Terminal Block

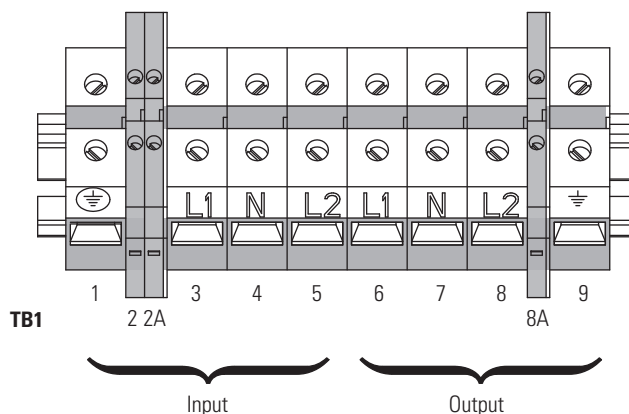

4.3.3 Input Isolation Transformer Installation

The Eaton 9155 has the following power connections:

- 2-phase (L1 and L2), neutral, and ground connection for rectifier/bypass input
- 2-phase (L1 and L2), neutral, and ground connection for load output



CAUTION

- The input isolation transformer output is always 240V (180° phase angle).
- If installing a Maintenance Bypass Module (MBM) or Power Distribution Module (PDM), the UPS MUST be set up for 240V output only; otherwise, the “Bypass Not Available” alarm annunciates. Any equipment connected to the output requiring 208V (120° phase angle) is at risk for damage when using the maintenance bypass switch.

Output overcurrent protection and disconnect switch must be provided by others.

[Figure 39](#) and [Figure 40](#) show the oneline diagrams of the input isolation transformer with the UPS.



WARNING

Only qualified service personnel (such as a licensed electrician) should perform the UPS installation and initial startup. Risk of electrical shock.

To hardwire the input isolation transformer and UPS (all hardware is supplied in the accessory kit):

1. Verify that the electrical connections to the installation site have been properly installed.
2. A wall-mounted, user-supplied, readily-accessible disconnection device must be incorporated in the input wiring.

Compare the circuit breaker ratings and wire sizes to the specifications in [Table 5](#).

i NOTE To accommodate the feature of easy system expandability, it is recommended that initial installation of the Eaton 9155 UPS contain wiring to support the maximum capacity of the UPS cabinet.

3. Switch off utility power to the distribution point where the UPS will be connected. Be absolutely sure there is no power.
4. Determine your equipment's grounding requirements according to your local electrical code.
5. Verify that the UPS battery circuit breaker is in the OFF position (see [Figure 18](#)).
6. Verify that the input circuit breaker is in the OFF position.
7. Remove the UPS wiring access cover and retain.
8. Remove the input isolation transformer wiring cover and retain.

Figure 18. UPS with Input Isolation Transformer Rear View

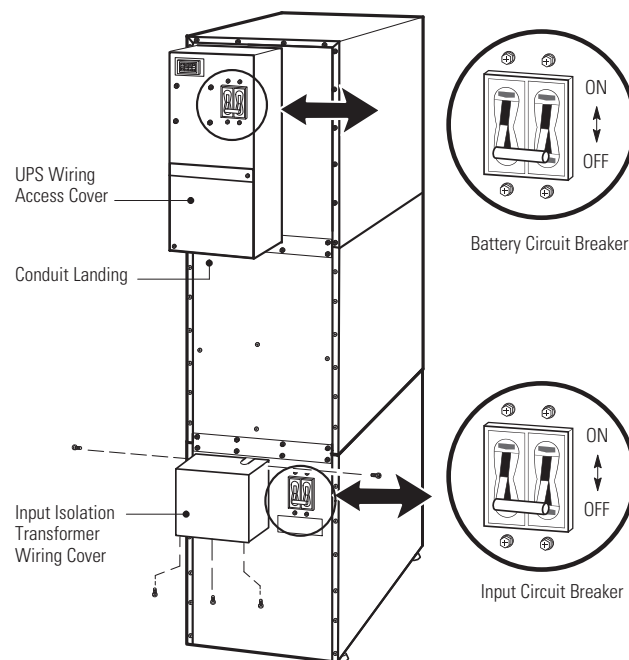

9. If you are also installing an optional MBM or PDM, proceed to [Step 15](#); otherwise, continue to [Step 10](#).
10. On the input isolation transformer, punch the two pilot holes in the conduit landing for the input and output conduit using a Greenlee® punch or similar device (see [Figure 19](#)).
11. Hardwire the input, output, and ground terminations for the input isolation transformer.
See [Table 4](#) for specifications and [Figure 17](#) for a detailed view of the UPS terminal block.

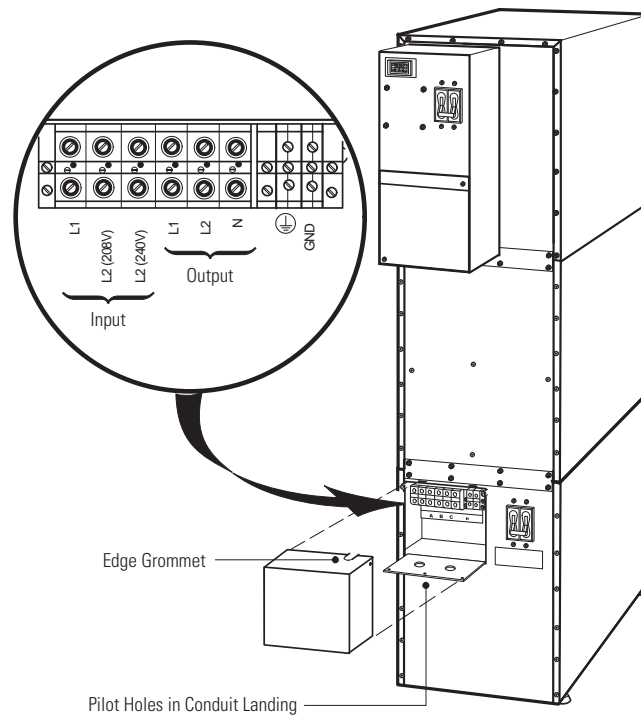
Figure 19. Input Isolation Transformer Hardwiring**NOTE**

Input neutral is supplied by the input isolation transformer.

12. Wire the output of the input isolation transformer terminal block to the UPS input terminal block (see [Table 4](#) and [Figure 17](#)).
13. Replace the UPS wiring access cover and the input isolation transformer wiring cover.
14. Continue to to complete the UPS installation.
15. On the input isolation transformer, punch one pilot hole in the conduit landing for the input conduit using a Greenlee punch or similar device (see [Figure 19](#)).
16. Install the supplied edge grommet in the top of the input isolation transformer wiring cover.
17. Hardwire the input terminations (TB1-1 through TB1-3) for the input isolation transformer.
See [Table 5](#) for specifications and [Figure 19](#) for a detailed view of the input isolation transformer terminal block.
18. Punch a hole in the bottom of the MBM/PDM using a Greenlee punch or similar device for wiring access.
Insert the supplied nylon bushing inside the wiring access hole.
19. Continue to to complete the installation.

4.3.4 UPS-Mounted Bypass Switch Installation

This section describes the Maintenance Bypass Module (MBM) and Power Distribution Module (PDM) installation. Both modules have a Make-Before-Break (MBB) maintenance bypass switch.

4.3.4.1 MBM/PDM Setup

If you purchased an optional MBM/PDM, attach the module to the UPS before any wiring installation. All hardware is supplied in the accessory kit.

To attach the optional MBM/PDM to the UPS:

1. Remove the connecting plate between the top cabinet and the cabinet below it on the UPS rear panel (see [Figure 20](#)). Discard the plate. Retain the screws for later use.
2. Remove the lowest top cover screw on each side of the UPS and discard.

Figure 20. UPS Rear View (2-High Cabinet Shown)

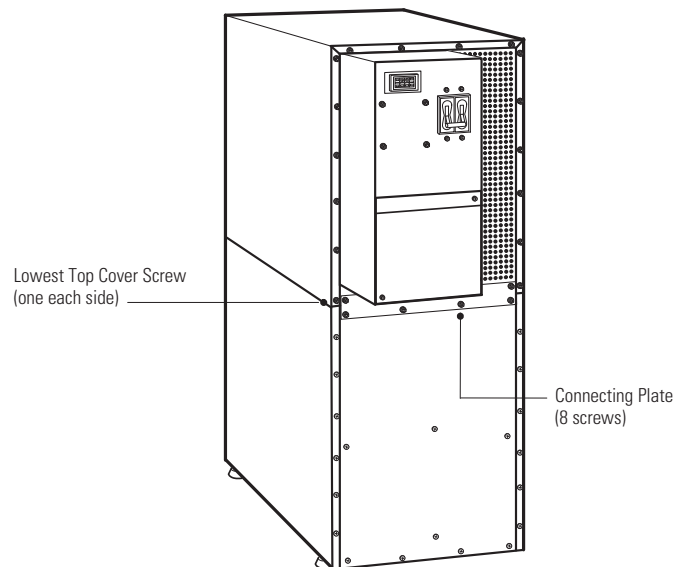

3. Attach the supplied L-bracket to the lower rear (for 2-high) or middle rear (for 3-high) cabinet using three screws (see [Figure 21](#)).

Repeat for the other side.

4. Remove the UPS wiring access cover and retain.

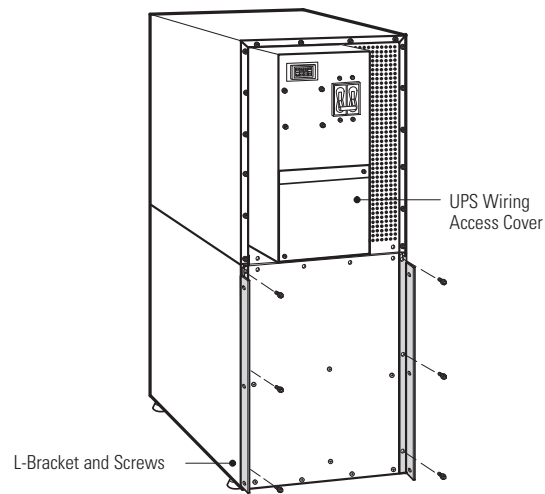
Figure 21. Attaching the L-Brackets

5. Remove the MBM/PDM wiring access cover and one of the conduit landing plates and retain (See [Figure 22](#)).
6. Tilt the top of the module forward and slide the module onto the L-brackets. The top left flange on the module fits up under the UPS electronics unit through an access slot.

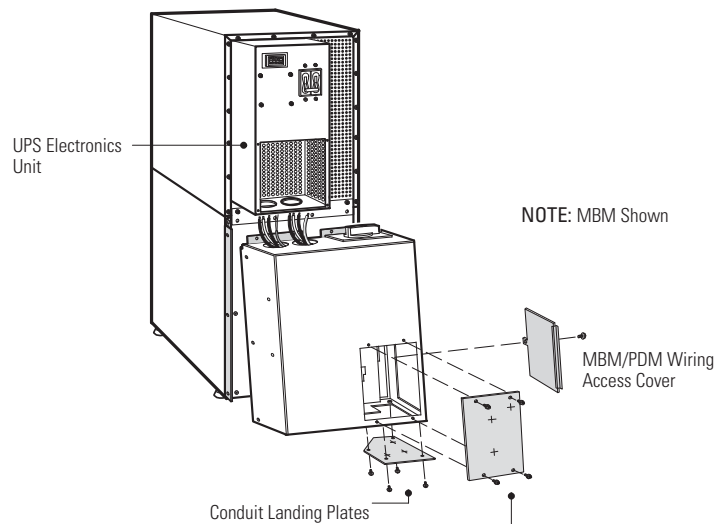
Figure 22. Installing the MBM or PDM

7. Secure the sides of the module to the L-brackets using six screws (see [Figure 23](#)).
8. Secure the top of the module to the top cabinet using four of the screws removed in [Step 1](#).

9. Continue to paragraph [4.3.4.2 Wiring the MBM/PDM](#).

Figure 23. Securing the MBM or PDM

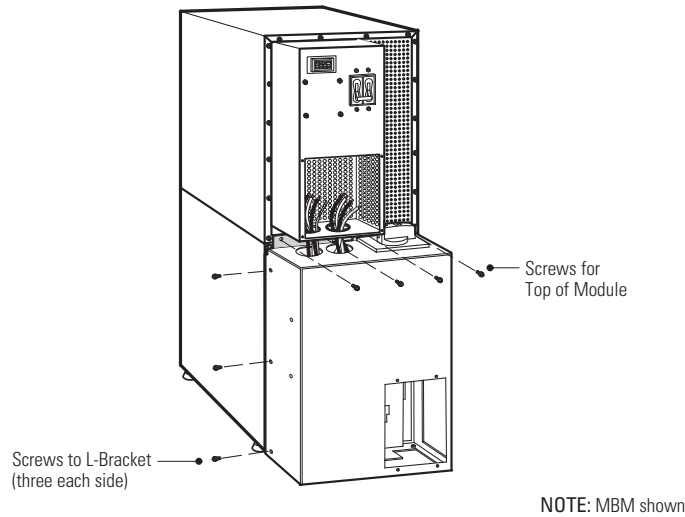

4.3.4.2 Wiring the MBM/PDM

The Eaton 9155 UPS has the following power connections:

- 2-phase (L1 and L2), neutral, and ground connection for rectifier/bypass input
- 2-phase (L1 and L2), neutral, and ground connection for load output

The nominal input/output voltages are:

- 100/200, 110/220, or 120/240 Vac with 180° phase displacement
- 120/208 or 127/220 Vac with 120° phase displacement

Output overcurrent protection and disconnect switch must be provided by others.

[Figure 41](#) and [Figure 42](#) show the oneline diagrams of the MBM and PDM with the UPS.

⚡ WARNING

Only qualified service personnel (such as a licensed electrician) should perform the UPS installation and initial startup. Risk of electrical shock.

To hardwire the MBM/PDM:

1. Verify that the electrical connections to the installation site have been properly installed.
2. A wall-mounted, user-supplied, readily-accessible disconnection device must be incorporated in the input wiring.

Compare the circuit breaker ratings and wire sizes to the specifications in [Table 6](#).

i NOTE To accommodate the feature of easy system expandability, it is recommended that initial installation of the Eaton 9155 UPS contain wiring to support the maximum capacity of the UPS cabinet.

3. Switch off utility power to the distribution point where the UPS will be connected. Be absolutely sure there is no power.
4. Determine your equipment's grounding requirements according to your local electrical code.
5. Verify that the UPS battery circuit breaker is in the OFF position (see [Figure 24](#)).

Figure 24. UPS with MBM Rear View

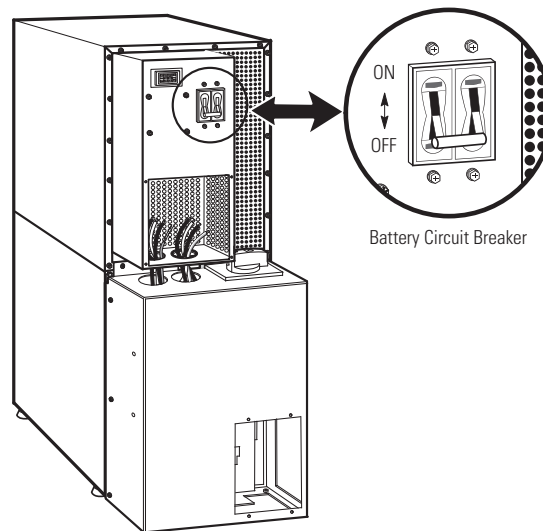

6. Punch two holes in the MBM/PDM conduit landing plate for the input and output conduit using a Greenlee punch or similar device.
7. Hardwire the input, output, and ground terminations for the MBM/PDM.
See [Table 6](#) for specifications and [Figure 19](#) for a detailed view of the MBM/PDM terminal block.

Figure 25. MBM/PDM Hardwiring

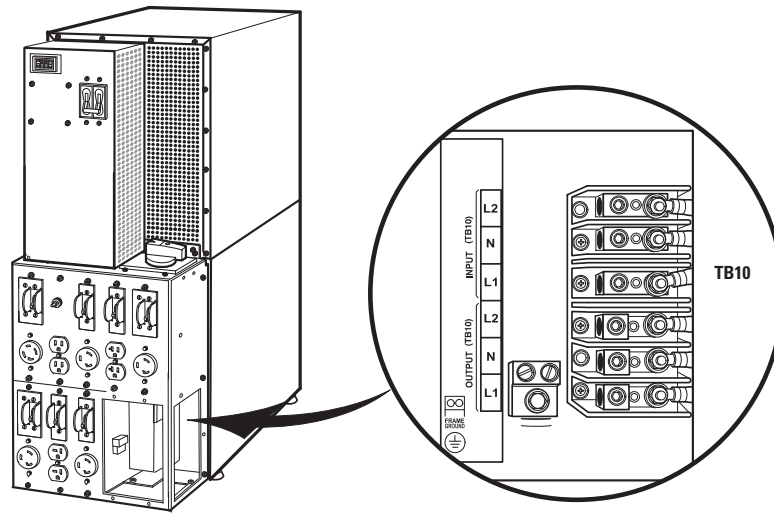

NOTE: PDM shown



NOTE

Input neutral must be wired for proper operation. Failure to connect an input neutral will void the warranty. However, when wired with the optional isolation transformer, input neutral is supplied by the isolation transformer.

8. Connect the factory-installed wiring from the maintenance bypass switch to the UPS terminal block (see [Figure 26](#)).

Connect the maintenance bypass (red and black) wires to TB1-2 (the A/B maintenance bypass auxiliary contacts) on the UPS terminal block.

Figure 26. Wiring from Maintenance Bypass Switch to UPS

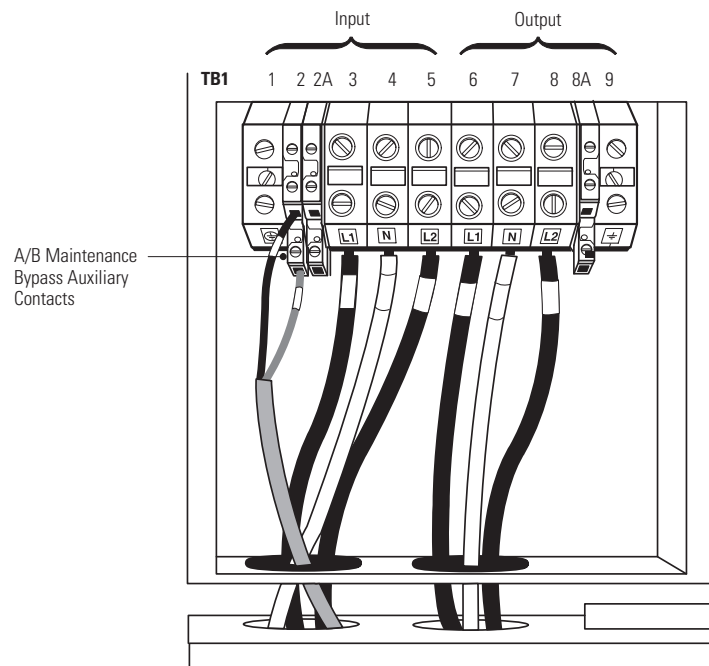

9. Replace the wiring access cover on the UPS and the optional isolation transformer, if applicable.
10. Replace the MBM/PDM wiring access cover and conduit landing plate.
11. Continue to paragraph [4.4 Stabilizing the Cabinet](#) to complete the installation.

4.3.5 Bypass Power Module Installation

For complete details on the installation process, and operation of the Eaton Bypass Power Module, refer to the **Eaton Bypass Power Module (BPM) User's Guide**, listed in paragraph [1.5 For More Information](#).

[Figure 27](#) shows the Eaton Bypass Power Module and its dimensions.

Figure 27. Bypass Power Module Dimensions

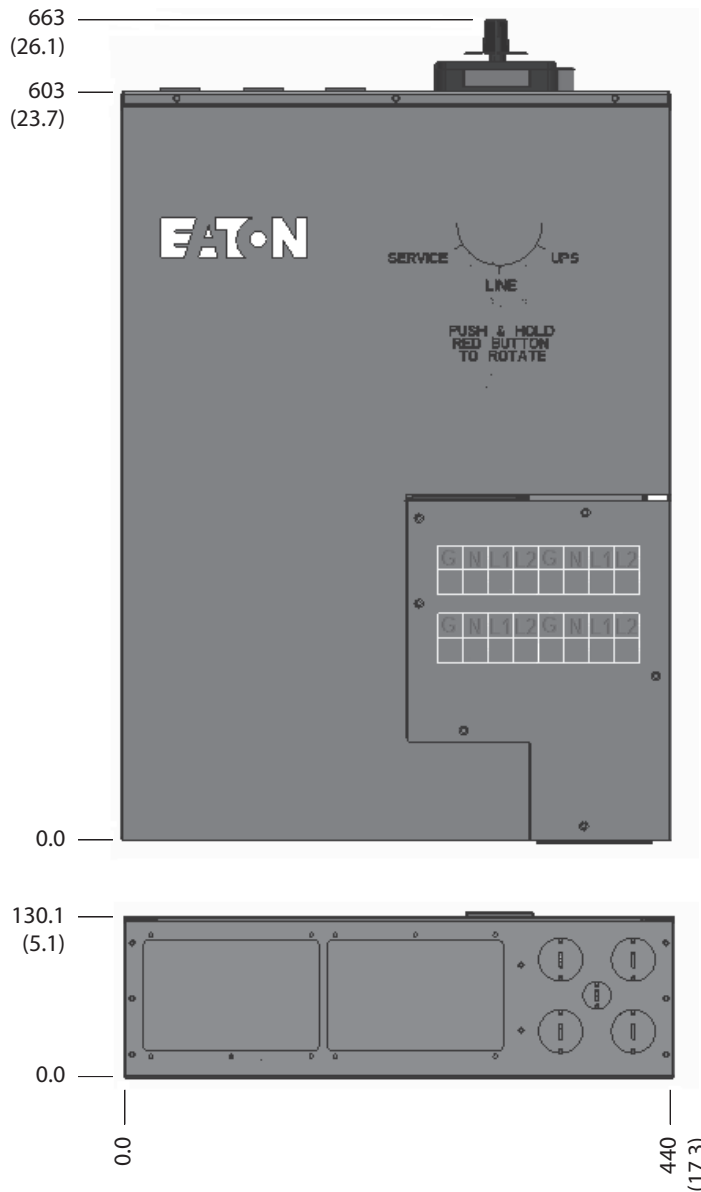

Dimensions are in millimeters [inches]

4.4 Stabilizing the Cabinet

NOTE 1 For seismic installations, you **MUST** order and install an Eaton 9155 UPS seismic kit; do not use the following instructions.



NOTE 2 For non-seismic installations, you **MUST** install the stabilizing bracket on all 3-high cabinets. The stabilizing bracket is optional for 2-high cabinets.

To stabilize the cabinet(s):

1. Lower the leveling feet to prevent the cabinet from rolling (see [Figure 28](#)).

Figure 28. Lowering the Leveling Feet

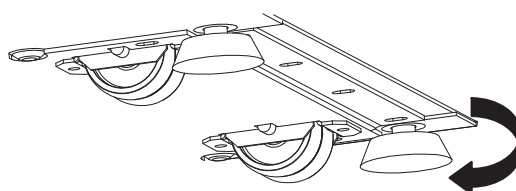

2. Attach the stabilizing bracket to the bottom of the cabinet rear panel using the retained hardware from the shipping pallet according to the cabinet configuration:
 - For one cabinet, see [Figure 29](#).
 - For two cabinets, see [Figure 30](#).
 - For three cabinets, see [Figure 31](#).



NOTE No more than three cabinets can be attached together. For four cabinets, use two of the two-cabinet installations. For five cabinets, use one three-cabinet and one two-cabinet installation.

3. Use the holes and slots in the bottom of the bracket to attach the cabinet to the flooring if desired.
4. Continue to one of the following sections:
 - See paragraph [4.5 Internal Battery Tray Wiring Connections](#) to install the internal battery tray wiring.
 - See paragraph [4.6 Extended Battery Module Installation](#) to install optional EBMs.
 - See [Chapter 6 Communication](#) to install UPS communication options, such as X-Slot cards or remote emergency power-off (REPO).
 - See [Chapter 7 UPS Operating Instructions](#) to start up the UPS system.

Figure 29. Stabilizing Bracket with One Cabinet

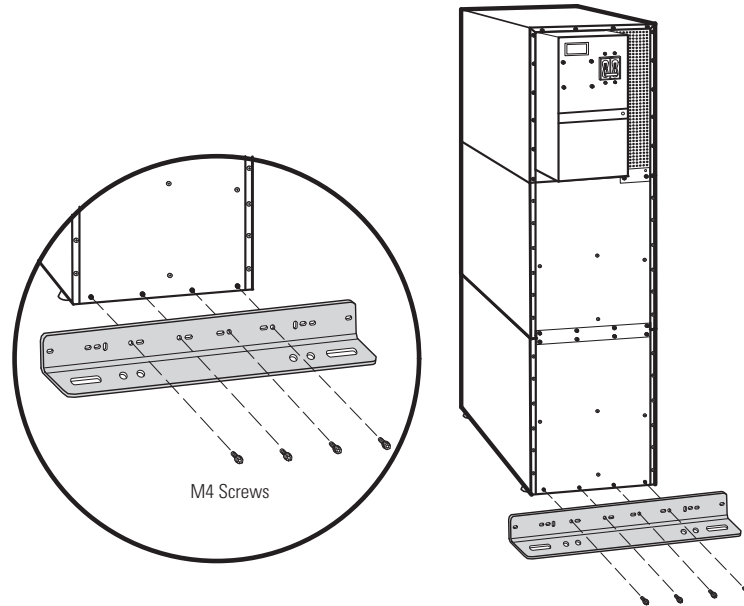

Figure 30. Stabilizing Bracket with Two Cabinets

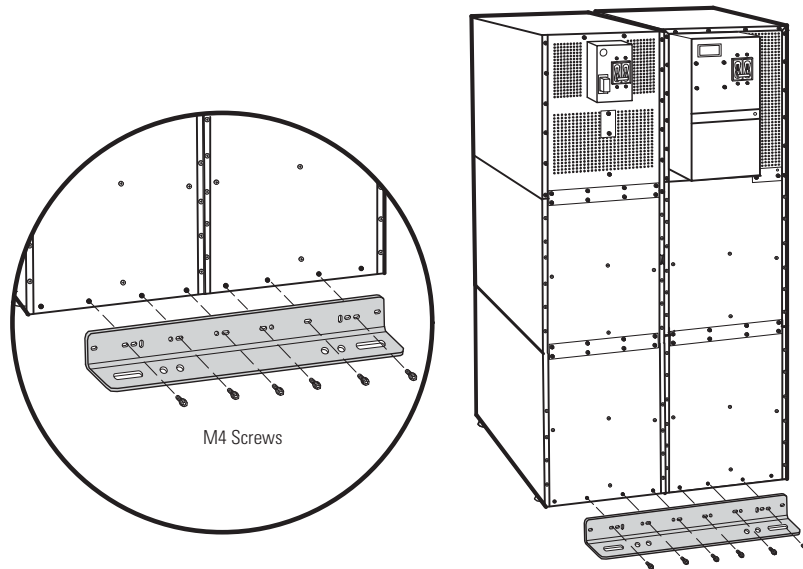
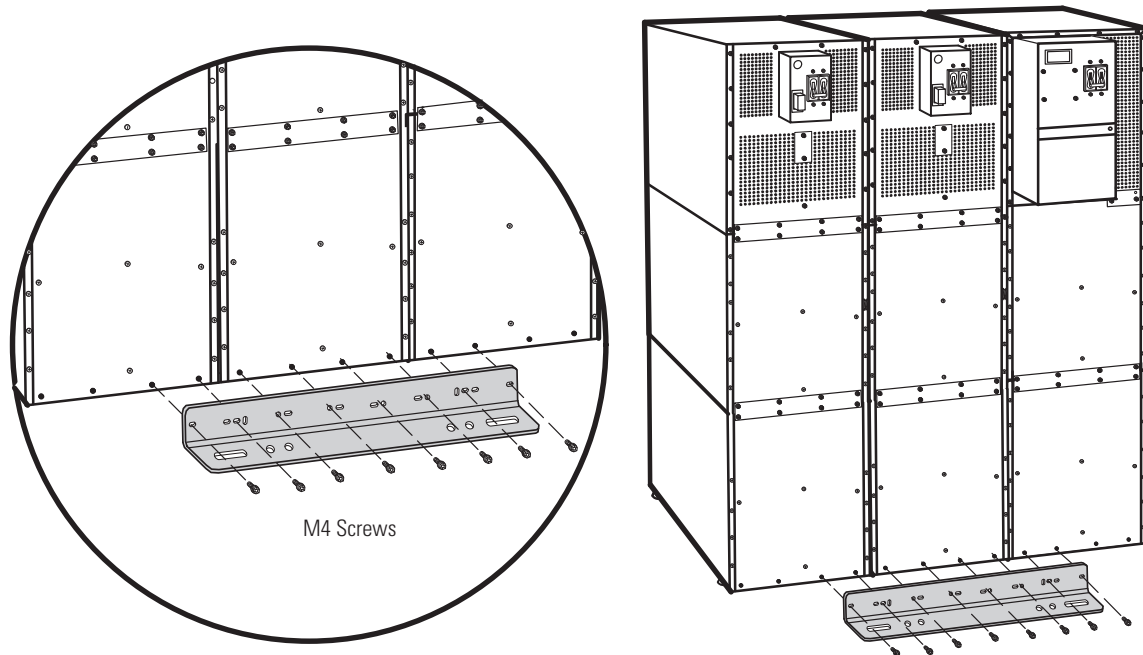

Figure 31. Stabilizing Bracket with Three Cabinets



4.5 Internal Battery Tray Wiring Connections

NOTE

To reduce electrical safety risks during transportation, the UPS is shipped with the internal battery tray assemblies disconnected.

DANGER

This UPS contains LETHAL VOLTAGES. All repairs and service should be performed by AUTHORIZED SERVICE PERSONNEL ONLY. There are NO USER SERVICEABLE PARTS inside the UPS.

WARNING

The UPS is intended to be operated only with batteries installed. When batteries are not installed a stabilizing bracket is required to prevent a tip hazard.

WARNING

Only qualified service personnel (such as a licensed electrician) should perform the UPS installation. Initial startup must be performed by an authorized Eaton Customer Service Engineer. Risk of electrical shock.

CAUTION

- Servicing should be performed by qualified service personnel knowledgeable of batteries and required precautions. Keep unauthorized personnel away from batteries.
- Batteries can present a risk of electrical shock or burn from high short circuit current. The following precautions should be observed: 1) Remove watches, rings, or other metal objects; 2) Use tools with insulated handles; 3) Do not lay tools or metal parts on top of batteries; 4) Disconnect charging source prior to connecting or disconnecting battery terminals; 5) Wear voltage rated gloves and electrical hazard footwear.
- When replacing batteries, replace with the same type and number of batteries or battery packs. Contact your service representative to order new batteries.
- Proper disposal of batteries is required. Refer to your local codes for disposal requirements.
- Never dispose of batteries in a fire. Batteries may explode when exposed to flame.
- Do not open or mutilate the battery or batteries. Released electrolyte is harmful to the skin and eyes and may be extremely toxic.
- Determine if the battery is inadvertently grounded. If inadvertently grounded, remove source of ground. Contact with any part of a grounded battery can result in electrical shock. The likelihood of such shock will be reduced if such grounds are removed during installation and maintenance.
- **ELECTRIC ENERGY HAZARD.** Do not attempt to alter any battery wiring or connectors. Attempting to alter wiring can cause injury.

To access and install the internal battery trays and wiring connections:

1. Verify that the input, output, and battery circuit breakers are in the OFF position
2. Remove the front covers of all cabinets, starting with the top cabinet.

Press and release the handle latch at the bottom of each cover and then lift the cover up and off the cabinet (see [Figure 32](#)).

Figure 32. Removing the Front Covers

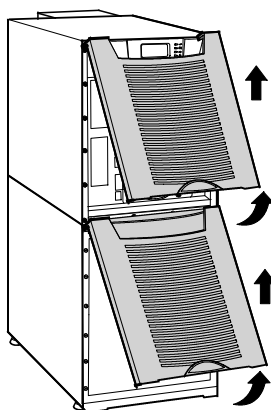

3. The battery cover panel is made up of two parts joined together with four screws. Remove both parts of the panel at the same time by removing the 10 M4 screws on the edges of the panel and M4 screw in the middle of the panel (see [Figure 33](#)).

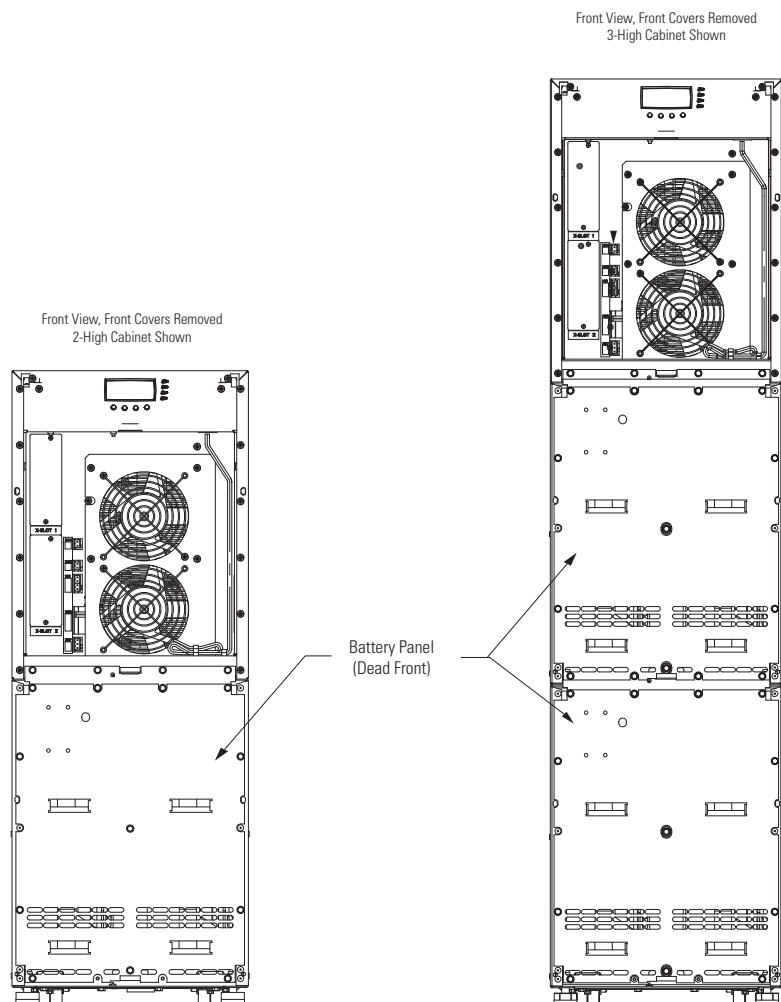
Figure 33. Battery Panel (Dead Front)

4. Connect the UPS battery wiring to the Battery tray wiring, red connector to red connector, black connector to black connector (see [Figure 34](#) and [Figure 35](#)).

Figure 34. Internal Battery Tray Wiring Connections

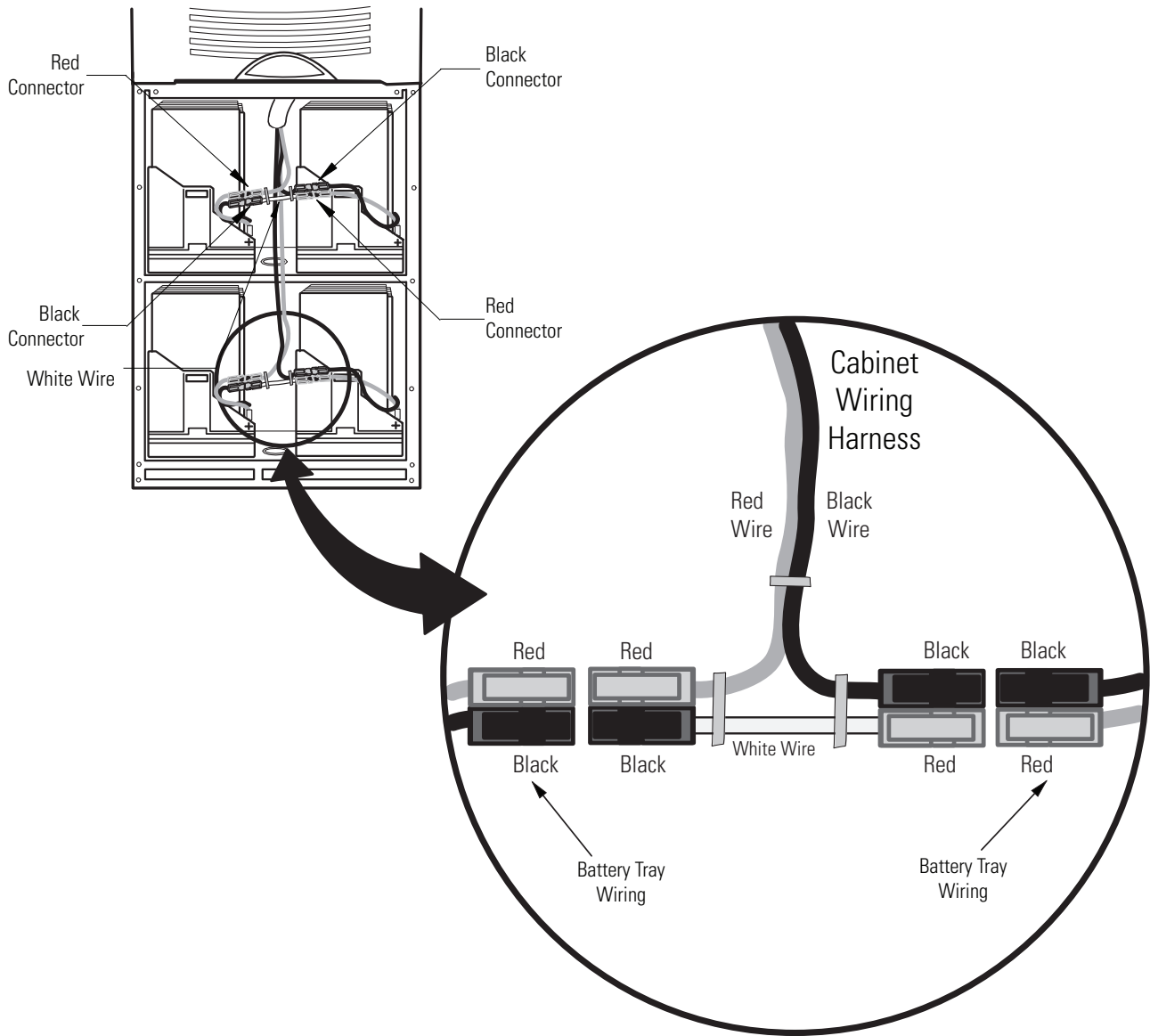
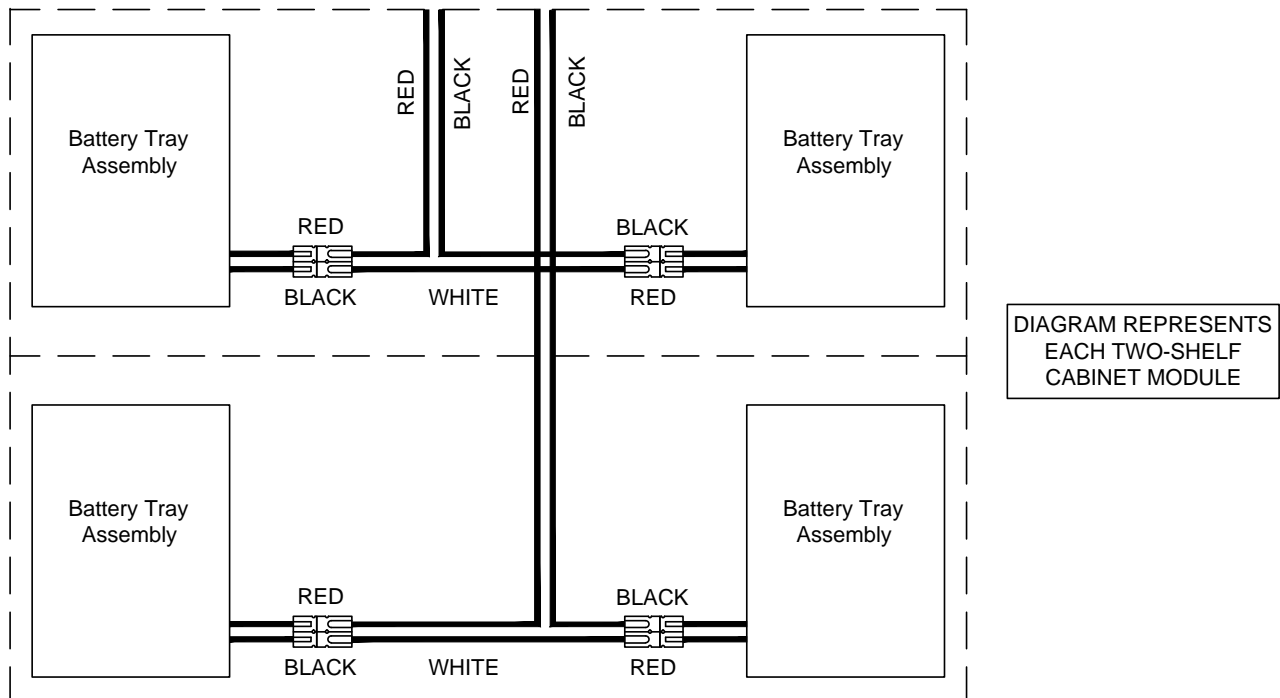

Figure 35. Internal Battery Tray Wiring Diagram

5. Repeat these steps to connect each battery tray to the UPS-Battery wiring harness.
6. Continue to one of the following sections:
 - See paragraph [4.6 Extended Battery Module Installation](#) to install optional EBMs.
 - See [Chapter 6 Communication](#) to install UPS communication options, such as X-Slot cards or remote emergency power-off (REPO).
 - See [Chapter 7 UPS Operating Instructions](#) to start up the UPS.

4.6 Extended Battery Module Installation

NOTE 1 A maximum of 22 battery strings can be installed in one configuration, including UPS batteries (4 EBM-64 models or 3 EBM-96 models). UPS-32 models contain 2 strings; UPS-64 models contain 4 strings; EBM-64 models contain 4 strings; and EBM-96 models contain 6 strings.



NOTE 2 For non-seismic installations, you **MUST** install the stabilizing bracket on all 3-high cabinets. The stabilizing bracket is optional for 2-high cabinets.

To install the optional Extended Battery Module (EBM):

1. Position the EBM adjacent to the next cabinet.
2. Verify that all battery circuit breakers are in the OFF position (see [Figure 36](#)).
3. Remove the two ground straps from the EBM rear panel.

4. Install one ground strap between the UPS and EBM rear panels as shown in [Figure 36](#).
5. If additional EBMs are installed, attach another ground strap between the first and second EBM. Repeat for each additional EBM.
6. Plug the EBM cable into the UPS battery connector.
7. If additional EBMs are installed, plug the EBM cable of the second cabinet into the battery connector on the first EBM. Repeat for each additional EBM.

Figure 36. Typical EBM Installation (2-High Cabinets Shown)

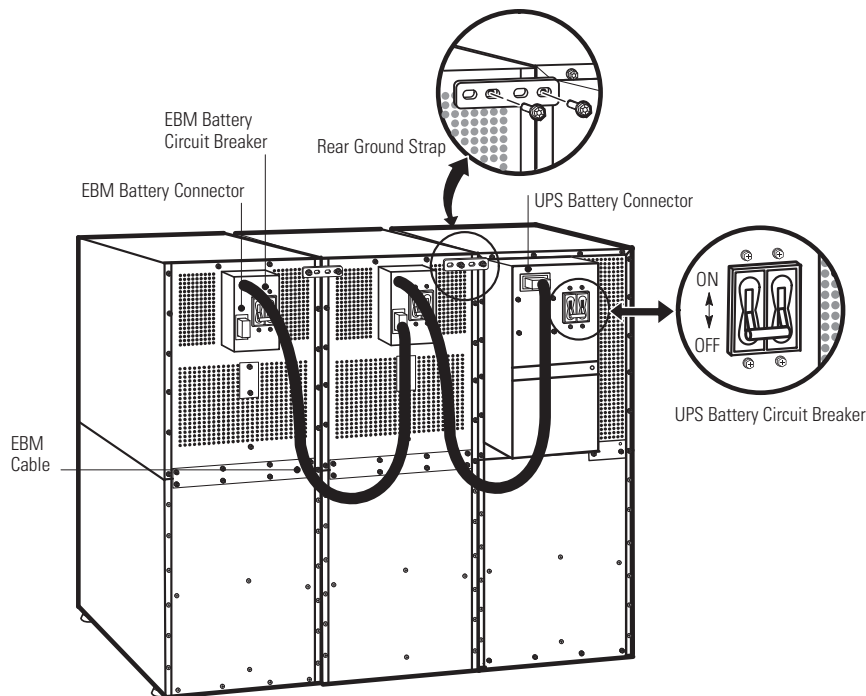

8. Remove the top front covers of all cabinets.
Press and release the handle latch at the bottom of the cover and then lift the cover up and off the cabinet.
9. Install the remaining ground straps between each cabinet (see [Figure 37](#)).
10. Reinstall the top front covers removed in [Step 8](#).
Hang the top edge of the cover on the cabinet first, then lower the bottom edge and snap into place.
11. Continue to one of the following sections:
 - See [Chapter 6 Communication](#) to install UPS communication options, such as X-Slot cards or remote emergency power-off (REPO).
 - See [Chapter 7 UPS Operating Instructions](#) to start up the UPS system.



NOTE

After UPS startup, ensure maximum battery runtime by configuring the UPS for the correct number of EBMs (see paragraph [7.5 Configuring the UPS for EBMs](#)).

Figure 37. Front Ground Strap Installation (2-High Cabinets Shown)

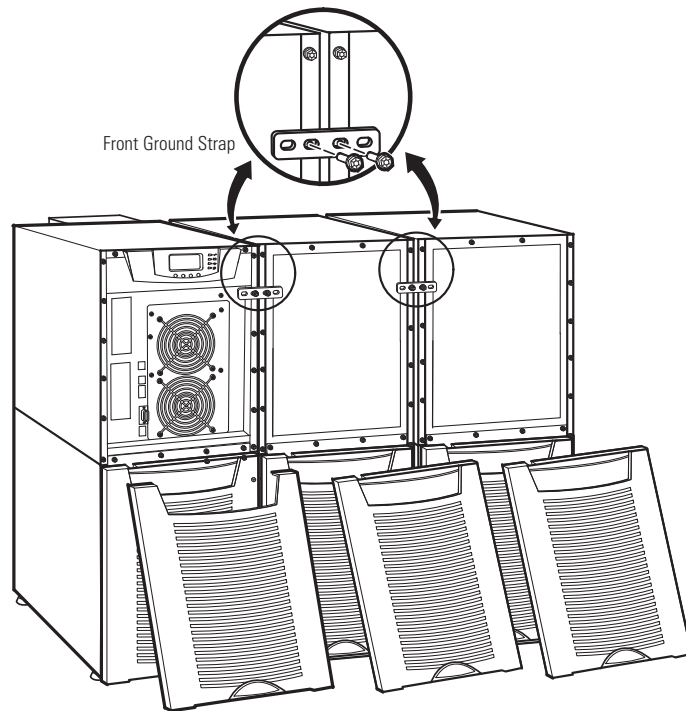

Chapter 5 UPS Wiring Diagrams and Schematics

Figure 38. UPS Only Wiring Diagram

Note: Diagram illustrates one out of two battery strings (2-high configuration) or four battery strings (3-high configuration). Battery symbol shown represents a battery tray assembly containing 8 batteries.

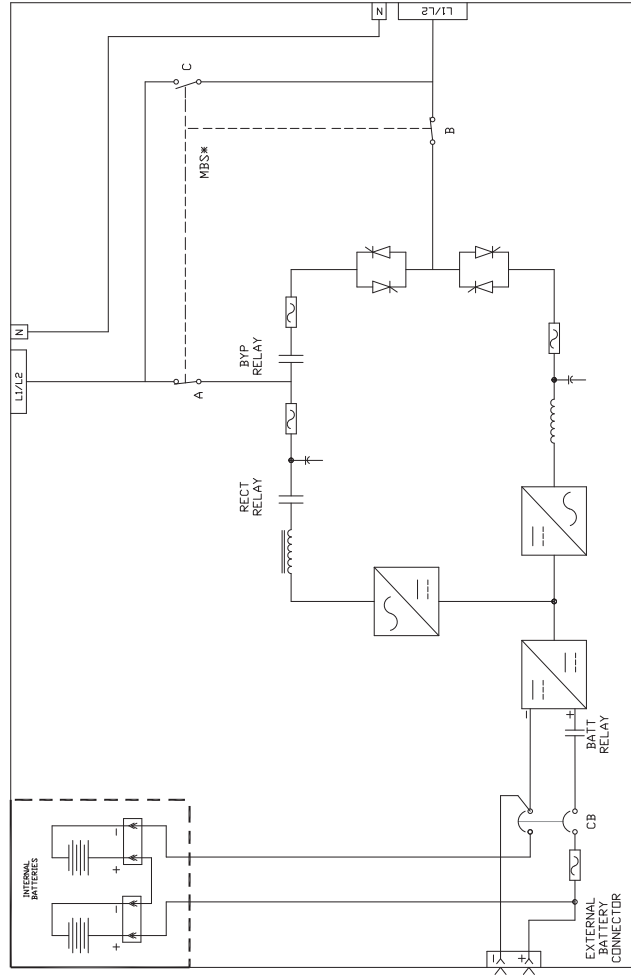

One-line diagram for 9155 8-15 kVA 2 or 3-High UPS with internal batteries

Notes:

1. Use only 90°C-Rated copper wire, minimum wire size is based on 120/208 full load ratings applied to Nation Electrical Code®(NEC®) Table 310.15(B)(16). Code may require a larger AWG size than shown in this table because of temperature, number of conductors in the conduit, or long service runs. Follow local requirements.
2. Per NEC article 300-20(A) for ferrous metal raceways, all three-phase conductors must be run in the same conduit. Neutral and ground must be run in the same conduit as the phase conductors.
3. Conduit is sized to accommodate one neutral conductor the same size as the phase conductor and one ground conductor. If two neutral conductors or an oversized neutral conductor are to be installed, check the size of the conduit needed to accommodate the extra wire or size and use that conduit size in place of the conduit size listed. Conduit sizes were chosen from NEC table C1, type letters RHH, RHW, RHW-2, TW, THW, THHW, THW-2.

Figure 39. UPS with Input Isolation Transformer Wiring Diagram

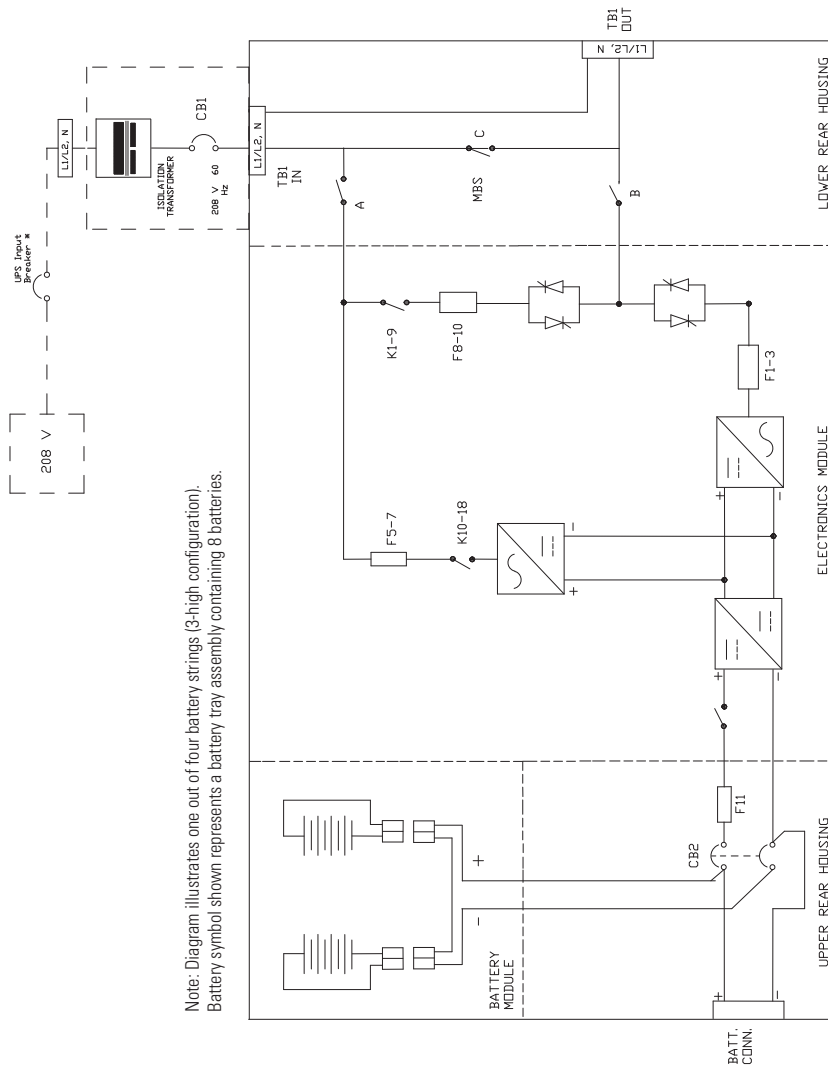

Note: Diagram illustrates one out of four battery strings (3-high configuration). Battery symbol shown represents a battery tray assembly containing 8 batteries.

One-line diagram for 9155 8-15 kVA 3-High UPS with Input Transformer Module and internal batteries

Notes:

1. Use only 90° C-Rated copper wire, minimum wire size is based on 120/208 full load ratings applied to Nation Electrical Code®(NEC®) Table 310.15(B)(16). Code may require a larger AWG size than shown in this table because of temperature, number of conductors in the conduit, or long service runs. Follow local requirements.
2. Per NEC article 300-20(A) for ferrous metal raceways, all three-phase conductors must be run in the same conduit. Neutral and ground must be run in the same conduit as the phase conductors.
3. Conduit is sized to accommodate one neutral conductor the same size as the phase conductor and one ground conductor. If two neutral conductors or an oversized neutral conductor are to be installed, check the size of the conduit needed to accommodate the extra wire or size and use that conduit size in place of the conduit size listed. Conduit sizes were chosen from NEC table C1. type letters RHH, RHW, RHW-2, TW, THW, THHW, THW-2.

Figure 40. UPS with Input Isolation Transformer and MBM/PDM Wiring Diagram

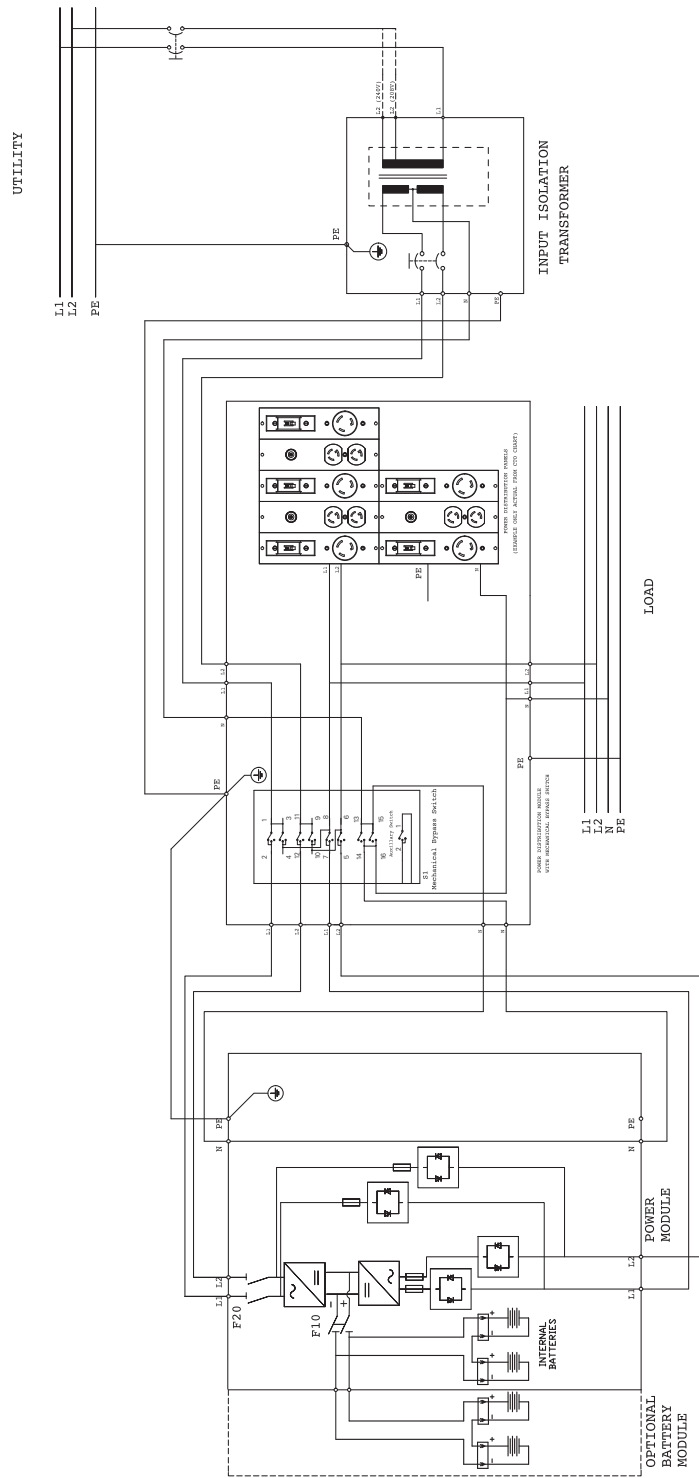

Figure 41. UPS with MBM Wiring Diagram

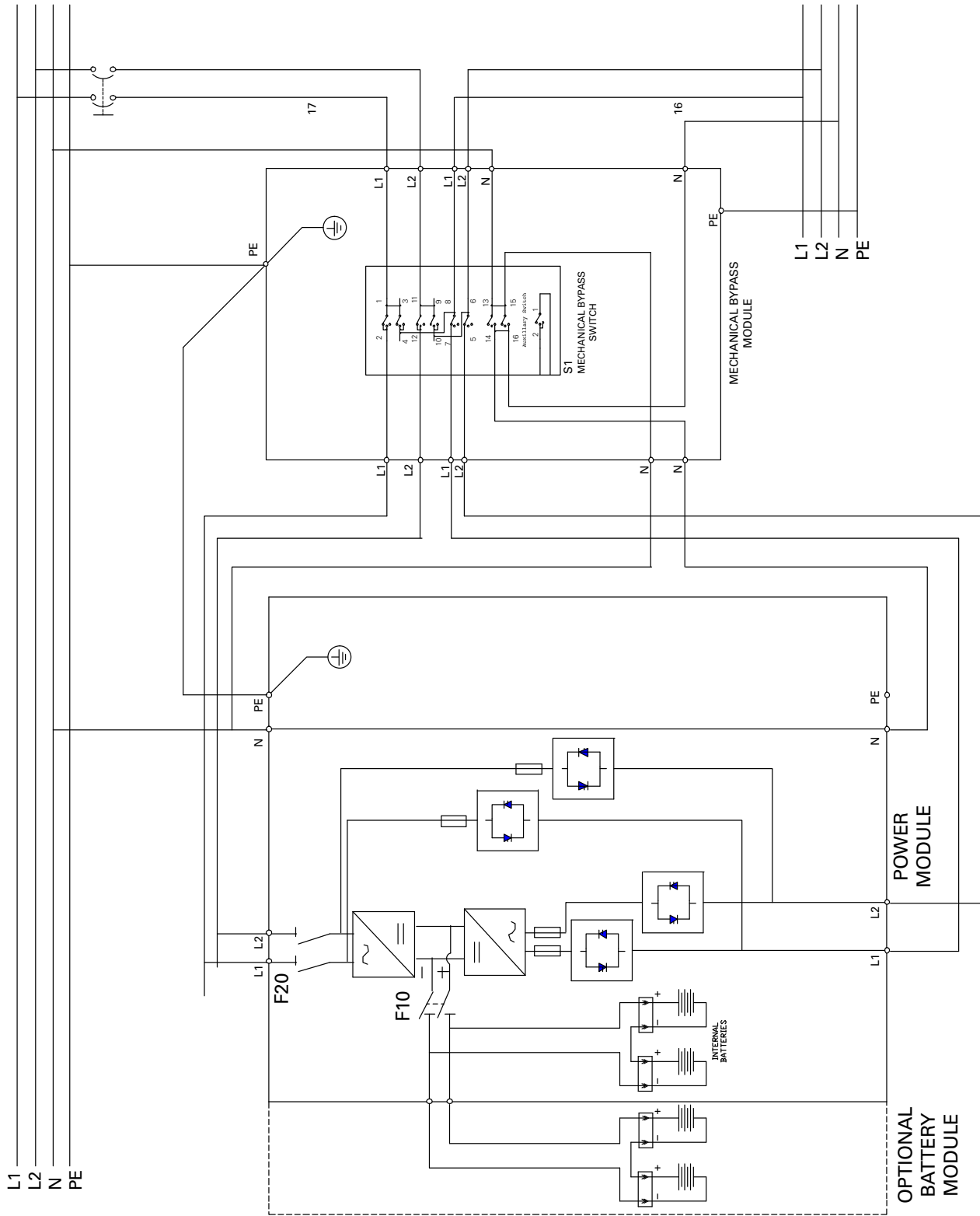
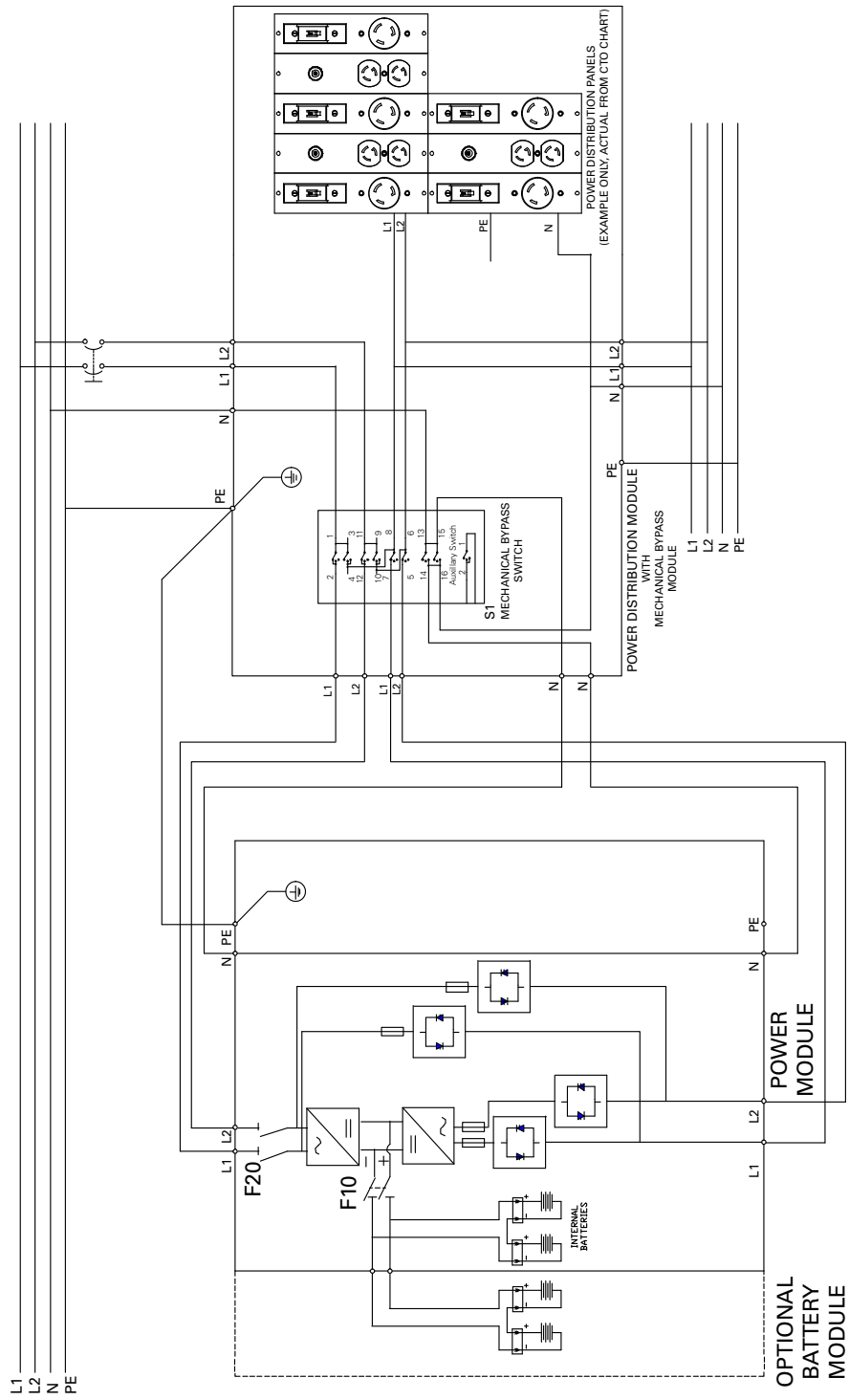

Figure 42. UPS with PDM Wiring Diagram



Chapter 6 Communication

This section describes the:

- DB-9 communication port
- X-Slot cards
- Power Management Software
- Remote emergency power-off (REPO)
- Relay output contacts
- Programmable signal inputs

[Figure 43](#) shows the location of the communication options and control terminals on the UPS.

Figure 43. Communication Options and Control Terminals

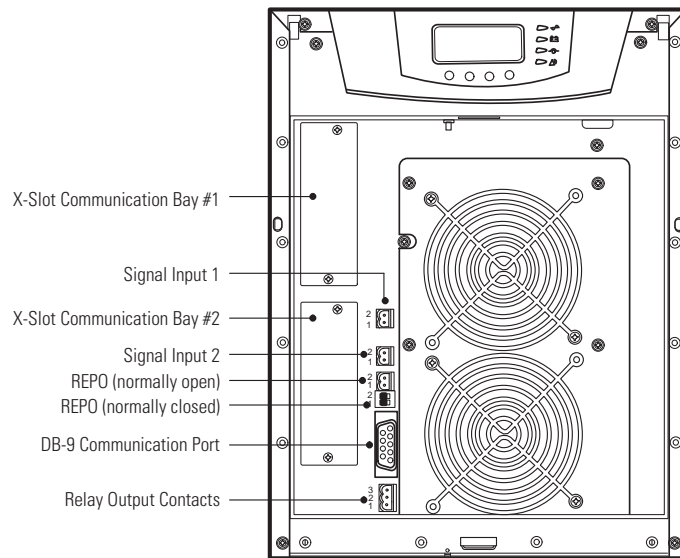

6.1 Installing Communication Options and Control Terminals

To access and install the communication options and control terminals:

1. Remove the front covers of all cabinets, starting with the top cabinet.

Press and release the handle latch at the bottom of each cover and then lift the cover up and off the cabinet (see [Figure 44](#)).

Figure 44. Removing the Front Covers

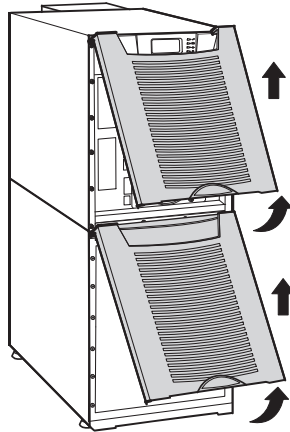

2. Install the appropriate X-Slot card and/or necessary cable(s) into the top cabinet (see [Figure 43](#) and [Figure 45](#)).

Figure 45. Installing Communication Cables

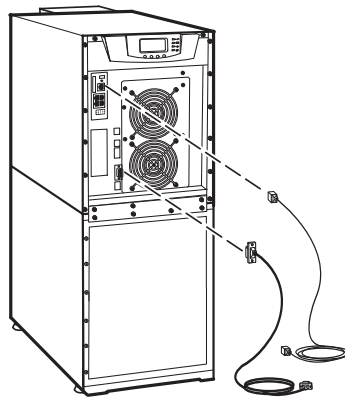

3. On the bottom cover (and also the middle cover if 3-high), remove a knockout tab in the top edge of the cover for each cable:
With wire cutters, cut either side of the tab and twist down to remove the tab (see [Figure 46](#)).

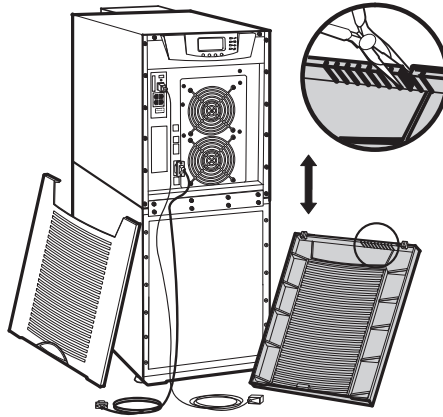
Figure 46. Removing Knockout Tabs

4. Route the cable(s) to the approximate location of the cover access holes.
5. Connect the cables to the appropriate location.
See paragraph [6.2 Communication Options](#) or [6.3 Control Terminals](#) for detailed information.
6. Reinstall the front covers, starting with the bottom cabinet (see [Figure 47](#)).
Hang the top edge of the cover on the cabinet first, then lower the bottom edge and snap into place. Be sure the cables fit in the access holes in the covers.
7. Continue to [Chapter 7 UPS Operating Instructions](#) to start up the UPS.

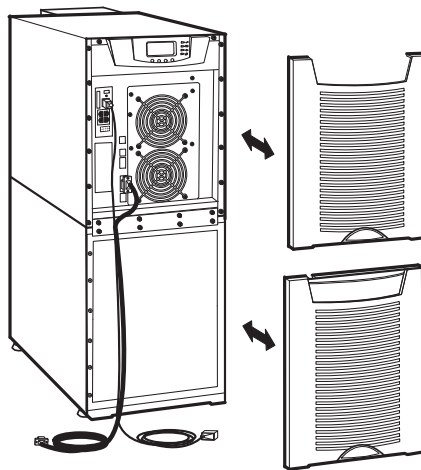
Figure 47. Reinstalling the Front Covers

6.2 Communication Options

The Eaton 9155 has serial communication capabilities through the DB-9 communication port or through an X-Slot card in one of the available bays. In addition, the power management software can be installed and used to communicate with the UPS via one of the serial communication connections.

The UPS supports two serial communication devices according to the following table:

Independent	Multiplexed	
X-Slot 1	X-Slot 2	DB-9 Communication Port
Any X-Slot card	Any X-Slot card except the Eaton Modem Card	Not in use
Any X-Slot card	Eaton Relay Interface Card Powerware Hot Sync® CAN Bridge Card	Available
Any X-Slot card	Not in use	Available



NOTE

You can configure relays, signal inputs, and the serial port baud rate through the front panel menus (see [Table 10](#)).

6.2.1 DB-9 Communication Port

To establish communication between the UPS and a computer, connect your computer to the UPS communication port using the supplied communication cable.

When the communication cable is installed, power management software can exchange data with the UPS. The software polls the UPS for detailed information on the status of the power environment. If a power emergency occurs, the software initiates the saving of all data and an orderly shutdown of the equipment.

The cable pins are identified in [Figure 48](#) and the pin functions are described in [Table 7](#). See [Figure 43](#) for the communication port location.

Figure 48. Communication Port

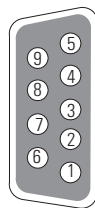

Table 7. Communication Port Pin Assignment

Pin Number	Signal Name	Function	Direction from the UPS
2	TxD	Transmit to external device	Out
3	RxD	Receive from external device	In
5	GND	Signal common (tied to chassis)	—

6.2.2 X-Slot Cards

X-Slot cards allow the UPS to communicate in a variety of networking environments and with different types of devices. The Eaton 9155 has two available communication bays for any X-Slot card, including:

- **ConnectUPS -X Web/SNMP Card** – has SNMP and HTTP capabilities as well as monitoring through a Web browser interface; connects to a twisted-pair Ethernet (10/100BaseT) network. It has a built-in switching hub that allows three additional network devices to be connected to the network without the requirement of additional network drops. In addition, a Environmental Monitoring Probe can be attached to obtain humidity, temperature, smoke alarm, and security information.
- **Relay Interface Card** – has isolated dry contact (Form-C) relay outputs for UPS status: Utility failure, Low battery, UPS alarm/OK, or On bypass.
- **Modbus® Card** – allows you to continuously and reliably monitor the UPSs in your Building Management System (BMS).
- **Industrial Relay Card (IRC)** – is used to indicate the operating status of the UPS system using the customer’s monitoring equipment. The IRC uses four isolated normally-open or normally-closed dry relay contacts to indicate the UPS status. Normal, Bypass, Battery, and Alarm mode can be monitored.
- **Multi-Server Card** – has six serial communication ports that can communicate simultaneously with other computers using power management software (provided on the Software Suite CD).
- **Modem Card** – provides out-of-band remote notification and monitoring using modem communication directly to cell phones and pagers.
- **Single-Port Card** – provides serial communication.
- **ConnectUPS-MX SNMP Card** – has Ethernet, modem, and SNMP capabilities.
- **USB Card** – connects to a USB port on your computer.



NOTE

The Eaton 9155 does not detect plug-and-play hardware. Before installing the USB Card, set the UPS baud rate to 1200 through the front panel (see [Table 10](#)).

See [Figure 43](#) for the location of the two X-Slot communication bays.

Figure 49. Optional X-Slot Cards

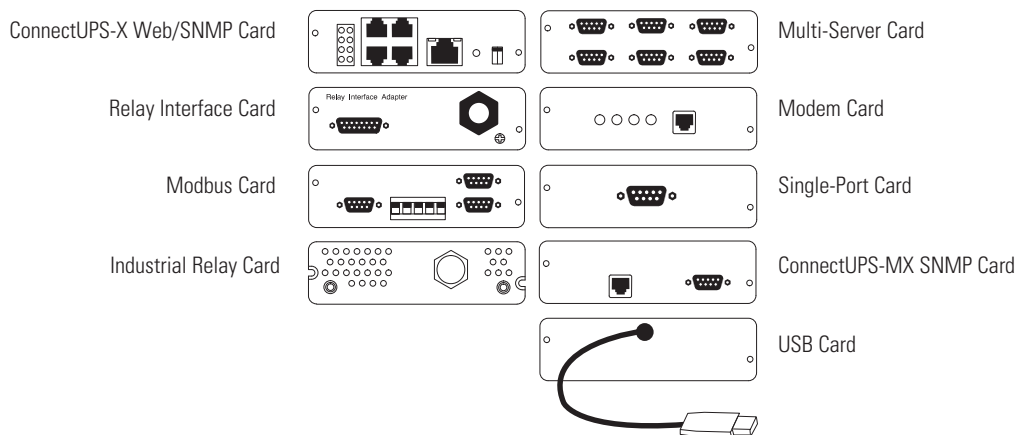

6.2.3 Power Management Software

Each Eaton 9155 UPS ships with power management software and an interface cable. To begin installing power management software, see the instructions accompanying the Software Suite CD.

i NOTE Use only the supplied communication cable to connect the UPS to your computer.

Power management software provides up-to-date graphics of UPS power and system data and power flow. It also gives you a complete record of critical power events, and it notifies you of important UPS or power information. If there is a power outage and the Eaton 9155 UPS battery power becomes low, power management software can automatically shut down your computer system to protect your data before the UPS shutdown occurs.

6.3 Control Terminals

The cables should be connected to the control terminals with a mating connector. Input and output terminals have a functional isolation from terminal to terminal. They are connected to the UPS chassis through individual 1 MΩ resistors.

Figure 50. External Control Terminal Connections

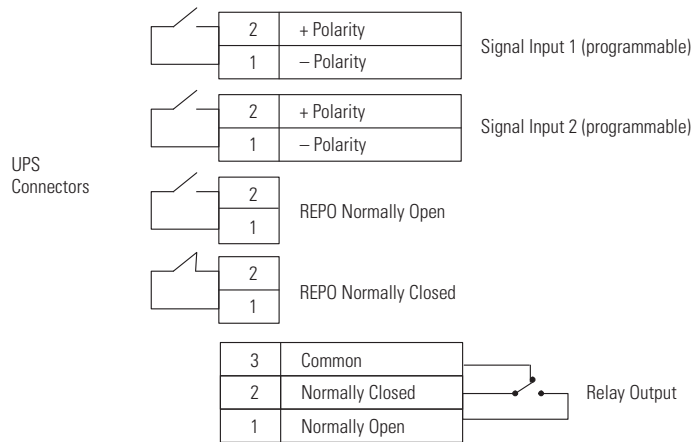

NOTE: If using a semiconductor switch type, pay attention to the proper polarity. A relay or other mechanical control is preferred.

i NOTE If using a semiconductor switch type, pay attention to the proper polarity. A relay or other mechanical control is preferred

6.3.1 Remote Emergency Power-off

REPO is used to shut down the UPS from a distance. This feature can be used for shutting down the load and the UPS by thermal relay, for instance in the event of room overtemperature. When REPO is activated, the UPS shuts down all converters, de-energizes all system relays, trips the battery circuit breaker, and fully powers down within 10-15 seconds.

There are two REPO positions that may be used, normally-open or normally-closed.

The pins on the normally-closed REPO connector are connected together. When this connection is open, the logic circuitry completely shuts down the UPS, thus preventing the power from supplying the load.

If the use of normally-closed REPO operation is desired, replace the connector with a normally-closed external switch (see [Figure 43](#)).

If the use of normally-open REPO operation is desired, connect a normally-open external switch (see [Figure 43](#)).

-
- 

NOTE 1 To restart the UPS, reconnect the REPO connector pins and turn on the UPS manually. The pins must be shorted to keep the UPS running. Maximum resistance is 10 ohm.
 - 

NOTE 2 Leave the REPO connector installed in the REPO port on the UPS even if the REPO function is not needed.
-

 **CAUTION**

- The REPO must not be connected to any utility connected circuits. Reinforced insulation to the utility is required. The REPO switch must have a minimum rating of 24 Vdc and 20 mA.
 - To ensure the UPS stops supplying power to the load during any mode of operation, the input power must be disconnected from the UPS when the emergency power-off function is activated.
-

REPO Connections		
Wire Function	Terminal Wire Size Rating	Suggested Wire Size
REPO	L1	12–22 AWG (4–0.32 mm ²)
	L2	
		18 AWG (0.82 mm ²)

6.3.2 Relay Output Contacts

The UPS incorporates a programmable relay output with potential free contacts for remote alarm indications (see [Figure 43](#)). An additional four relay outputs can be obtained with the X-Slot compatible Relay Interface Card.

 **WARNING**

The relay output contacts must not be connected to any utility connected circuits. Reinforced insulation to the utility is required. The relay output contacts have a maximum rating of 30 Vac/1A and 60 Vdc/2A nominal values.

6.3.3 Programmable Signal Inputs

The UPS incorporates two programmable signal inputs (see [Figure 36](#) on page 49). Use of non-polar (relay) control input is recommended. The pins must be shorted with maximum resistance of 10 ohm in order to activate the specific input.

-
- 

NOTE See [Figure 50](#) for the polarity and verify these connections if polarity control is required.
-

The default and programmable settings for the signal inputs are shown in [Table 8](#).

Table 8. Programmable Signal Inputs

Signal	Description
Disable Bypass Operation	If active, the automatic transfer to the static bypass is prevented.
Charger Off	If active, the battery charge function is disabled. In a utility power outage, the discharge of batteries is supported.
Remote ON/OFF	If active, the UPS output turns off regardless of the mode of operation. Auxiliary power, fan, communication, and rectifier/battery charger remain functional. Restart is initiated immediately when this signal is inactive.
Request Bypass	If active, the UPS transfers to bypass if the bypass voltage, frequency, and synchronization are all okay.
Request Normal	If active, the UPS transfers to inverter operation if not prohibited by REPO or an alarm condition.
Force Bypass	If active, the UPS is forced to static bypass operation regardless of the bypass status.
External Battery Breaker Status	If active, the UPS knows that the batteries are disconnected.
Building Alarm 1–6	These alarms can be activated separately or at the same time with other building alarms.
Not in Use	Default
Shutdown	If active, the UPS shuts down immediately.
Delayed Shutdown	If active, the UPS shuts down after a user-configured delay time. Default shutdown delay is 120 seconds. The UPS automatically restarts when the signal changes to inactive.
Normal/Bypass	If active, the UPS transfers to bypass if okay. If inactive, the UPS transfers to the inverter when possible.
On Generator	If active, the UPS knows that input is fed from the generator. Bypass is disabled; the automatic battery test is disabled.
External Transformer Overtemperature	This option is not used.

Chapter 7 UPS Operating Instructions

This chapter contains information on how to use the Eaton 9155, including front panel operation, UPS startup and shutdown, operation of the maintenance bypass switch, and configuring the UPS for Extended Battery Modules (EBMs).



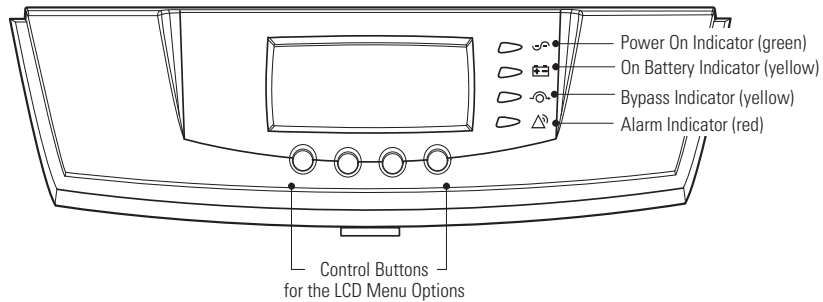

7.1 Control Panel Functions

The UPS has a four-button graphical LCD with backlight. It provides useful information about the UPS itself, load status, events, measurements, and settings (see [Figure 51](#)).

Figure 51. Eaton 9155 Control Panel



The following table shows the indicator status and description.

Indicator	Status	Description
 Green	On	The UPS is operating normally.
	Flashing	A new information message is active.
	Off	The UPS is turned off and will not turn on automatically.
 Yellow	On	The UPS is in Battery mode.
 Yellow	On	The UPS is in Bypass mode.
 Red	On	The UPS has an active alarm.
	Flashing	There is a new UPS alarm condition. See Chapter 9 Troubleshooting for additional information.





7.1.1 Changing the Language

Press and hold the first button on the left for approximately five seconds to select the language menu. This action is possible from any LCD menu screen.

7.1.2 Display Functions

As the default or after 15 minutes of inactivity, the LCD displays the selectable startup screen. The default is the Eaton logo and can be changed to the Mimic screen in the User Settings menu.

The backlit LCD automatically dims after a long period of inactivity. Press any button to restore the screen.

Use the two middle buttons ( and ) to scroll through the menu structure. Press the  button to enter a submenu. Press the  button to select an option. Press the  button to cancel or return to the previous menu.

The following table shows the basic menu structure.

Table 9. Menu Map for Display Functions

Main Menu	Submenu	Display Information or Menu Function
UPS Status		UPS off / System normal / UPS supporting load / UPS on battery / UPS on bypass / Active alarm list / Battery status
Event Log		Displays up to 127 events and alarms
Measurements	Output	L-N and L-L / Current / Frequency / Power
	Battery	Voltage / Current / Runtime
	Input	L-N and L-L / Current / Frequency
	Bypass	L-N and L-L / Frequency
Control	Go to Bypass Mode	Transfers the UPS to internal Bypass mode When this command is active, the option changes to Go to Normal Mode.
	Start Battery Test	Initiates a battery test
	Display Test	Four different selectable tests for the front panel functions: the LEDs cycle through, the alarm beep sounds, the backlight turns off and on, and the pixels scroll through to test the LCD.
Settings	User Settings	See Table 10 for more information.
	Service Settings	This screen is password-protected.
Identification		UPS Type / Part Number / Serial Number / Firmware / Display / CAN Bridge
Turn UPS ON/OFF	ON and OFF Options	

7.1.3 User Settings

The following table displays the options that can be changed by the user.



NOTE

Changes to the output voltage or frequency options should be made before turning on the UPS; otherwise, the changes do not take effect.

Table 10. User Settings

Description	Available Settings	Default Setting
Set Date and Time	Set Month Date: mm/dd/yyyy Time: 24:00	01/01/2003 00:00
Display Contrast	Adjust contrast with up/down arrow buttons	Moderate
Change Language	Select Language: <English> Elegir idioma <Español>	English
Relay Config	Relay: [Alarm 1] [X-Slot 1-1/2/3/4] or [X-Slot 2-1/2/3/4] Setup: [Battery Low] [On Battery] [On Bypass] [UPS ok] [custom] [empty]	Alarm 1: empty X-Slots (1 or 2) #1: UPS ok #2: On Bypass #3: Summary Alarm #4: On Battery
Signal Inputs	[empty] [Logic] (see paragraph 6.3.3 Programmable Signal Inputs for more information.)	<empty>
Serial Port Config	Port: [X-Slot-1] [X-Slot-2/Serv] Speed: [19200] [9600] [2400] [1200]	19200
Modem Config	Modem Installation	<Not Installed>
	Set Modem Call Events	Event #0 Call modem: no
	Set Modem Init String	ATZ0
	Set Modem Call Command	None
	Set Modem Communication Password	None
Start Screen	Eaton logo Mimic screen	Eaton logo
User Password	Enabled/Disabled If Enabled is selected, the password is USER.	Disabled
Audible Alarms	Normal Sound/Disabled	Normal Sound
Battery Charging	ABM cycling/constant	ABM cycling
Automatic Battery Tests	Enabled/Disabled Enabled automatically runs the battery test once a month.	Enabled
Full Power Battery Test	Enabled/Disabled	Enabled
Number of Battery Strings	0 through 22 (see paragraph 7.5 Configuring the UPS for EBMs for more information.)	2 strings for UPS-32 models 4 strings for UPS-64 models

Table 10. User Settings (Continued)

Description	Available Settings	Default Setting
Battery Capacity	1 through 65535 watts per cell	34 W/cell
Battery Low Alarm Level	1.750 through 1.950 volts per cell	1.880 V/cell
Set Nominal Output Voltage	Output: [120V/208V] [127V/220V]	120V/208V
Bypass Voltage High Limit	+1 through +20% (1% increments)	120V +10%
Bypass Voltage Low Limit	-1 through -20% (1% increments)	120V -15%
Nominal Output Frequency	50 Hz or 60 Hz	60 Hz
Synchronization	Enabled/Disabled	Enabled
Synchronization Window	±0.5 through ±3.0 Hz (0.1 Hz increments)	±2.0 Hz
Unsynchronized Transfer to Bypass	Allowed/Not Allowed	Not Allowed
Output Frequency Slew Rate	0.1 through 5 hertz per second (0.1 Hz increments)	0.5 Hz/s
Usage of Bypass	Enabled/Disabled	Enabled
Transfer to Bypass When Overload	After a delay/Immediately	After a delay
Automatic Start Delay	-1 through 32767 seconds (-1 means disabled)	0s
Control Commands from X-Slot1	Allowed/Disabled	Allowed
Control Commands from X-Slot2/Serv	Allowed/Disabled	Allowed
X-Slot Signal Input Activation Delay	0 through 65 seconds	5s
Input signal delayed shutdown delay	1 through 65535 seconds	120s
Site Wiring Fault Notice	Enabled/Disabled	Enabled
Reset Custom Event Settings	0 through 32	Total: 0/32
Auto Output Configuration	Enabled/Disabled	Enabled for initial startup Disabled after initial startup

7.2 Initial UPS Startup

Startup and operational checks must be performed by an authorized Eaton Customer Service Engineer, or the warranty terms specified on the product's resources page become void. See for details. This service is offered as part of the sales contract for the UPS. Contact an Eaton service representative in advance (a minimum two-week notice is required) to reserve a preferred startup date.



Only qualified service personnel (such as a licensed electrician) should perform the UPS installation. Initial startup must be performed by an authorized Eaton Customer Service Engineer. Risk of electrical shock.

Verify that UPS installation has been carried out correctly and the UPS ground has been connected.

Select one of the following startup options:

Startup Option	Section
Normal mode	See paragraph 7.2.1 Normal Mode Startup .
Battery mode	See paragraph 7.2.2 Starting the UPS on Battery .
Bypass mode	See paragraph 7.2.3 Internal Bypass Startup .
UPS maintenance bypass	See paragraph 7.2.4 Maintenance Bypass Startup .
Bypass Power Module	Refer to the Eaton Bypass Power Module (BPM) User's Guide .
Parallel UPS configuration	Refer to the Eaton 9155 Parallel UPS (8–15 kVA) User's Guide .





7.2.1 Normal Mode Startup

1. If you have an optional MBM/PDM, verify that the maintenance bypass switch is in the UPS position (see [Figure 52](#)).
2. If an optional isolation transformer is installed, switch the input circuit breaker to the ON position.
3. Switch ON the utility power where the UPS is connected.
4. Wait for the front panel LCD to illuminate.

The  indicator flashes.

5. Switch all battery circuit breakers to the ON position.

The  indicator stops flashing.

6. Press any button on the front panel display to activate the menu options.
7. Press the  button on the front panel display and then press the  button to select the TURN UPS ON/OFF menu.
8. Press the  or  button to select the TURN UPS ON option; press and hold the  button for three seconds, until the UPS stops beeping.

The  indicator illuminates. The UPS is now powering the load.

If the  indicator is flashing, check the UPS status from the front panel to view the active alarms. Correct the alarms and restart if necessary.

7.2.2 Starting the UPS on Battery



NOTE

Before using this feature, the UPS must have been powered by utility power at least once.





To start the UPS on battery:

1. If you have an optional MBM/PDM, verify that the maintenance bypass switch is in the UPS position (see [Figure 52](#)).
2. Switch all battery circuit breakers to the ON position.



NOTE

Leave the battery circuit breaker(s) in the ON position during this operation. If you need to cancel this operation, wait until the front panel LCD illuminates before switching the battery circuit breaker(s) off.

3. Wait for the front panel LCD to illuminate.
4. Press any button on the front panel display to activate the menu options.
5. Within three minutes, press the  button on the front panel display and then press the  button to select the TURN UPS ON/OFF menu.
6. Press the  or  button to select the TURN UPS ON option; press and hold the  button for three seconds, until the UPS stops beeping.

The UPS starts in Battery mode within two minutes and supplies battery power to your equipment.



and



are illuminated.

7.2.3 Internal Bypass Startup

To start the UPS in internal Bypass mode:

1. If you have an optional MBM/PDM, verify that the maintenance bypass switch is in the UPS position (see [Figure 52](#)).
2. If an optional isolation transformer is installed, switch the input circuit breaker to the ON position.



NOTE

When using the optional isolation transformer, Bypass mode is available only for 240V phase-phase (180° phase angle).

3. Switch ON the utility power where the UPS is connected.
4. Wait for the front panel LCD to illuminate.





The  indicator flashes.



5. Switch all battery circuit breakers to the ON position.





The  indicator stops flashing.

6. Press any button on the front panel display to activate the menu options.
7. Using the  button on the front panel display, scroll to the Control menu option and press the  button.
8. Press the  button to select the Go to Bypass Mode option.



The  and  indicators illuminate, indicating the UPS is operating in Bypass mode. The load is now powered by utility power.

To switch to Normal mode from internal Bypass mode:





1. Press the  button to select the Go To Normal Mode option.
2. Press the  button until the Eaton logo or Mimic screen appears.

7.2.4 Maintenance Bypass Startup

To start the UPS in maintenance bypass (UPS-mounted operation):

1. Verify that the maintenance bypass switch is in the BYPASS position (see [Figure 52](#)).
2. Switch ON the utility power where the UPS is connected.
The load is now powered by utility power.
3. To transfer the load to the UPS, see [7.4.2 Transfer the load from maintenance bypass to the UPS](#).

7.3 UPS Shutdown

1. Press any button on the front panel display to activate the menu options.
2. Press the  button on the front panel display and then press the  button to select the TURN UPS ON/OFF menu.
3. Press the  or  button to select the TURN UPS OFF option; press and hold the  button for three seconds, until the UPS stops beeping.
The input contactor opens.
4. Repeat [Step 3](#), two times.
5. Switch the UPS battery circuit breaker to the OFF position.
The UPS is disconnected from the batteries and is on logic power only.
6. Switch Off the utility power where the UPS is connected.

7.4 UPS Bypass Operation

The UPS-mounted maintenance bypass switch is part of the optional Maintenance Bypass Module (MBM) or Power Distribution Module (PDM) and is located on the back of the UPS (see [Figure 52](#)).

Figure 52. Maintenance Bypass Switch

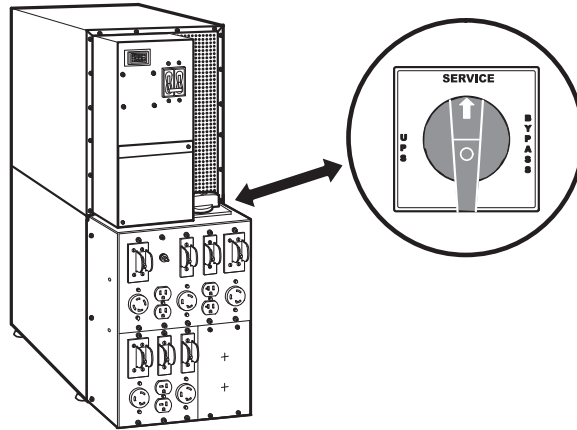

NOTE: PDM shown

The UPS-mounted bypass switch has three positions as described in [Table 11](#).



NOTE

In the UPS or SERVICE position, AC input power is still connected to the input terminals inside the UPS.

Table 11. UPS-Mounted Bypass Switch Positions

Switch Position	Description
UPS	Connects the UPS output to the load.
SERVICE	Connects the load directly to AC input power and disconnects UPS output. AC input power is still connected to the UPS input.
BYPASS	Like the SERVICE position, BYPASS connects the load directly to AC input power and disconnects UPS output. However, because BYPASS also disconnects AC input from the UPS, this is the appropriate position for UPS maintenance or repair.

[Figure 53](#) shows a UPS with a separate battery cabinet and a UPS-mounted bypass switch.

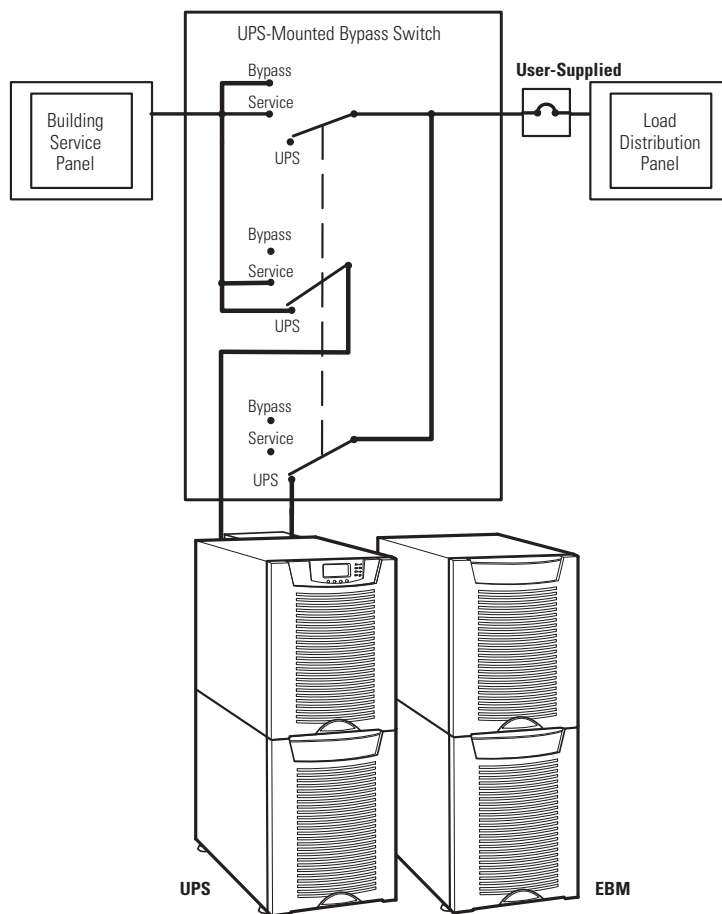
Figure 53. Typical Hardwired Installation with UPS-Mounted Bypass Switch

7.4.1 Transfer the load from the UPS to maintenance bypass

1. Remove the cables and screws for any ConnectUPS Web/SNMP or PXGX card and then remove the x-slot card.



NOTE

Before proceeding ensure that there are no active alarms or notices.

2. Set the system to internal Bypass mode:
 - Using the ↑ button on the front panel display, scroll to the **Control** menu option and press the → button.
 - Press the ← button to select the **Go to Bypass Mode** option.



The  indicator illuminates indicating the UPS system is operating in Bypass mode.
3. Turn the maintenance bypass switch on the back of the UPS to the SERVICE position (see [Figure 52](#)).

The Normal LED  will be flashing.

The UPS is now bypassed, with the load powered by utility power.

Verify the load has been transferred to bypass by viewing the output meters screen.

4. Command the UPS off.

Press the  button on the front display, scroll to the UPS On/Off menu. Press the  button to turn the UPS off.

Rear fan is running signifying load is being supplied utility power on bypass.

5. Switch all of the UPS battery circuit breakers to the Off position.
6. Turn the maintenance bypass switch on the back of the UPS to the Bypass position (see [Figure 52](#)).

7.4.2 Transfer the load from maintenance bypass to the UPS

1. Turn the maintenance bypass switch on the back of the UPS to the SERVICE position (see [Figure 52](#)).
2. Switch all of the UPS battery circuit breakers to the ON position.
3. Wait 1.5 to 2 minutes for the internal startup process to complete.

Wait until the bypass indicator illuminates and the two front fans are operating before proceeding to the next step.

Verify the output voltage is present on the meters screen.

4. Turn the maintenance bypass switch on the back of the UPS to the UPS position to return to Normal mode (see [Figure 52](#)).







When the green UPS normal indicator illuminates, the UPS is powering the load.

Verify the load is transferred to the UPS by viewing the output meters screen.

5. Reinstall any ConnectUPS Web/SNMP or PXGX cards, secure with retained hardware and connect cables.



7.5 Configuring the UPS for EBMs

To ensure maximum battery runtime, configure the UPS for the correct number of EBMs:

1. Press any button on the front panel display to activate the menu options.
2. Using the  button, scroll to the Settings menu.
3. Press the  button twice to select the User Settings menu.
4. Using the  button, scroll to the Battery Setup option and press the  button.
5. The “Number of Battery Strings will appear”, using the  or  buttons to select the number of strings according to your UPS configuration:

All 2-High UPS and EBM Cabinets*	Number of Strings
UPS + 1 EBM	6
UPS + 2 EBMs	10
UPS + 3 EBMs	14
UPS + 4 EBMs	18
All 3-High UPS and EBM Cabinets*	Number of Strings

UPS + 1 EBM	10
UPS + 2 EBMs	16
UPS + 3 EBMs	22
* UPS-32 models contain 2 strings; EBM-64 models contain 4 strings. UPS-64 models contain 4 strings; EBM-96 models contain 6 strings.	

6. Press the  button to save the setting.
7. Press the  button until the Eaton logo appears.

Chapter 8 UPS Maintenance

This section explains how to:

- Care for the UPS and batteries
- Recycle used batteries or UPS
- Use the maintenance bypass switch

8.1 UPS and Battery Care

For the best preventive maintenance, keep the area around the UPS clean and dust-free. If the atmosphere is very dusty, clean the outside of the system with a vacuum cleaner.

For full battery life, keep the UPS at an ambient temperature of 77°F (25°C).



NOTE

The batteries in the UPS are rated for a 3–5 year service life. The length of service life varies, depending on the frequency of usage and ambient temperature. Batteries used beyond expected service life will often have severely reduced runtimes. Replace batteries at least every 5 years to keep units running at peak efficiency.

8.2 Storing the UPS and Batteries

When storing the UPS and optional cabinets, the following requirements should be met:

- Verify that the battery circuit breaker is in the OFF position.
- Avoid temperature and humidity extremes. To maximize battery life, the recommended storage temperature is 59°F (15°C) to 77°F (25°C).
- If you store the UPS for a long period, recharge the batteries every 10 months by applying utility power. The batteries charge to 80% capacity in approximately 3 hours. However, it is recommended that the batteries charge for 48 hours after long-term storage.
- Check the battery recharge date on the shipping carton label. If the date has expired and the batteries were never recharged, do not use the UPS. Contact your service representative.

8.3 When to Replace Batteries



NOTE

Batteries must be replaced by authorized service personnel.



When the  indicator flashes and the LCD panel displays Battery Failure, the batteries may need replacing. Contact your service representative to replace the batteries. Change the batteries approximately every five years.

8.4 Recycling the Used Battery or UPS

Contact your local recycling or hazardous waste center for information on proper disposal of the used battery or UPS.

 **WARNING**

- Do not dispose of the battery or batteries in a fire. Batteries may explode. Proper disposal of batteries is required. Refer to your local codes for disposal requirements.
- Do not open or mutilate the battery or batteries. Released electrolyte is harmful to the skin and eyes. It may be toxic.

 **CAUTION**

Do not discard the UPS or the UPS batteries in the trash. This product contains sealed, lead-acid batteries and must be disposed of properly. For more information, contact your local recycling/reuse or hazardous waste center.

 **CAUTION**

Do not discard waste electrical or electronic equipment (WEEE) in the trash. For proper disposal, contact your local recycling/reuse or hazardous waste center.

Chapter 9 Troubleshooting

This section explains:

- Typical UPS alarms and conditions
- How to silence an alarm
- Service and support

9.1 Typical Alarms and Conditions

[Table 12](#) describes typical alarms and conditions; check the Event Log through the control panel for a list of active alarms. If an alarm appears with a service code, please contact the Help Desk, see paragraph [1.6 Getting Help](#).

Table 12. Troubleshooting Guide











Alarm or Condition	Possible Cause	Action
On Battery  LED is on. 1 beep every second	A utility failure has occurred and the UPS is in Battery mode.	The UPS is powering the equipment with battery power. Prepare your equipment for shutdown.
Battery Low  LED is on. Continuous beep for 10 seconds	The battery is running low.	Five minutes or less of battery power remains (depending on load configuration and battery charge). Save your work and turn off your equipment. When utility power is restored, the UPS restarts automatically, provides power to the load, and charges the battery.
Battery Breaker  LED is on. 1 beep every second	The UPS does not recognize the internal batteries.	Verify the battery circuit breaker is in the ON position. If the condition persists, contact your service representative.
Overload  LED is on. 1 beep every second	Power requirements exceed the UPS capacity (greater than 100% of nominal; see page 75 for specific output overload ranges).	Remove some of the equipment from the UPS. The UPS continues to operate, but may switch to Bypass mode if the load increases. The alarm resets when the condition becomes inactive.
Overtemperature  LED is on. 1 beep every second	UPS internal temperature is too high or the fan has failed.	If you have an optional Maintenance Bypass Module (MBM) or Power Distribution Module (PDM), turn the maintenance bypass switch to the SERVICE position. If you have a wall-mounted bypass switch, turn the maintenance bypass switch to the LINE position. Otherwise, shut down the UPS. Clear vents and remove any heat sources. Allow the UPS to cool.

Table 12. Troubleshooting Guide (Continued)

Alarm or Condition	Possible Cause	Action
		Ensure the airflow around the UPS is not restricted. If the alarm disappears, turn the maintenance bypass switch back to the UPS position (or restart the UPS if you do not have a switch). If the condition persists, contact your service representative.
Battery test failed	The batteries need service.	Contact your service representative.
The UPS does not start.	The main utility breaker is off.	Verify that the main utility breaker is on.
	If an optional isolation transformer is installed, the input circuit breaker is off.	Verify that the isolation transformer input circuit breaker is on.
	The remote emergency power-off (REPO) switch is active or the REPO connector is missing.	Reset the REPO switch and restart the UPS. Verify that the REPO connector is present.
Power is not available at the UPS output receptacles.	The UPS is in Standby mode.	Supply power to the connected equipment: Press any button on the front panel display to activate the menu options. Press the  button on the front panel display and then press the  button to select the TURN UPS ON/OFF menu. Press the  button to select the TURN UPS ON option; press the  button. Press and hold the  button for three seconds, until the UPS stops beeping.
The UPS does not provide the expected backup time.	The batteries need charging or service.	Apply utility power for 48 hours to charge the batteries. If the condition persists, contact your service representative.
	Battery circuit breakers are in the OFF position.	Switch all battery circuit breakers to the ON position.

9.2 Silencing the Alarm

Before silencing an alarm, check the alarm condition and perform the applicable action to resolve the condition (see [Table 12](#)).

To silence the alarm for an existing fault, press any button on the front panel display. If the alarm status changes, the alarm beeps again, overriding the previous alarm silencing.

Chapter 10 Product Specifications

This section provides the following specifications:

- Model list
- Dimensions and weights
- Environmental and safety specifications
- Technical specifications
- Model specifications
- Battery specifications
- Battery runtimes

Table 13. Model List

UPS	Description	Power Rating
9155-8-32	2-high: UPS with one battery section 3-high: UPS with one battery and one isolation transformer section	8 kVA, 7.2 kW
9155-8-64	3-high: UPS with two battery sections	8 kVA, 7.2 kW
9155-10-32	2-high: UPS with one battery section 3-high: UPS with one battery and one isolation transformer section	10 kVA, 9 kW
9155-10-64	3-high: UPS with two battery sections	10 kVA, 9 kW
9155-12-32	2-high: UPS with one battery section 3-high: UPS with one battery and one isolation transformer section	12 kVA, 10.8 kW
9155-12-64	3-high: UPS with two battery sections	12 kVA, 10.8 kW
9155-15-32	2-high: UPS with one battery section 3-high: UPS with one battery and one isolation transformer section	15 kVA, 13.5 kW
9155-15-64	3-high: UPS with two battery sections	15 kVA, 13.5 kW
Extended Battery Module (EBM)	Description	
9155-EBM-64	2-high: two battery sections	
9155-EBM-96	3-high: three battery sections	

Table 14. Dimensions and Weights

	Dimensions (H x W x D)	Weight
2-High UPS	32.2" x 12" x 33.5" (81 x 30 x 85 cm)	352 lb (160 kg)
3-High UPS-32	47.8" x 12" x 33.5" (121.5 x 30 x 85 cm)	550 lb (250 kg)
3-High UPS-64	47.8" x 12" x 33.5" (121.5 x 30 x 85 cm)	590 lb (268 kg)

Table 14. Dimensions and Weights (Continued)

	Dimensions (H x W x D)	Weight
2-High EBM	32.2" x 12" x 30.3" (81 x 30 x 77 cm)	480 lb (218 kg)
3-High EBM	47.8" x 12" x 30.3" (121.5 x 30 x 77 cm)	710 lb (322 kg)
PDM (rear UPS mount)	16.5" x 12" x 7" (42 x 30 x 17.8 cm)	25 lb (11 kg)
MBM (rear UPS mount)	16.5" x 12" x 7" (42 x 30 x 17.8 cm)	18 lb (8 kg)

Table 15. Environmental and Safety Specifications

Operating Temperature	50°F to 104°F (10°C to 40°C) Optimal battery performance: 77°F (25°C)
Transit Temperature	-13°F to 131°F (-25°C to 55°C)
Storage Temperature	32°F to 77°F (0°C to 25°C) Recommended battery storage: 59°F to 77°F (15°C to 25°C)
Ventilation	Front air intake, forced air, two fans, positive pressurization, temperature UPS-monitored
Altitude	9,843 ft (3,000m) operating without derating 32,810 ft (10,000m) during transportation
Relative Humidity	5-95% noncondensing
Heat Dissipation	5582 BTU/hr maximum online 5294 BTU/hr maximum on battery
Audible Noise	<56 dBA at 1 meter distance, typical loads <62 dBA for heavy load, high ambient or high altitude, on battery
Surge Suppression	ANSI C62.41 Category B3
Safety Conformance	NOM-019-SCFI, UL 1778, CSA C22.2, No. 107.3
Agency Markings	cULus, NOM-NYCE
EMC (Class A)	IEC 62040-2, FCC Part 15, ICES-003, VCCI

Table 16. Technical Specifications

Technology	Online, double-conversion, split-phase topology with static bypass switch and optional 3-position maintenance bypass switch. Frequency independent operation.
Input Voltage Range	75–144 Vac per phase
Isolation Transformer Input Voltage Range	208V or 240V ±20%
Input Power Factor	>0.99 at full load nominal line conditions
Input Rated Voltage	100/200, 110/220, or 120/240 Vac with 180° phase displacement 120/208 or 127/220 Vac with 120° phase displacement
Input Frequency Range	45–65 Hz

Table 16. Technical Specifications (Continued)

Input Rated Frequency	50/60-Hz selectable, auto configuring
Output Voltage Regulation	±1% static, Phase to Neutral ±2% static, Phase to Phase ±5% dynamic at 100% resistive load change Response time <1 ms
Output Voltage Distortion	<2% THD linear load <5% THD non-linear load
Output Frequency	50/60-Hz selectable or auto configuring
Output Frequency Regulation	Synchronization to line
Output Frequency Conversion	Frequency/phase-converter operation with derated output load capacity to 80%; Frequency Conversion mode can be configured through the front panel or through XCP commands. Bypass is not available in Frequency Conversion mode.
Output Overload	101–110% for 10 minutes 111–125% for 60 seconds 126–149% for 5 seconds >150% for 300 milliseconds

Table 17. Model Specifications

15 kVA Model					
Output Voltage (Line Line)	200	220	240	208	220
Output Voltage (Line Neutral)	100	110	120	120	127
Input Current*	71A	71A	71A	71A	67A
Output Current	63A	63A	63A	63A	59A
Output kVA (Line–Line Loads)	12.5	13.8	15.0	13.0	13.0
Output kVA (Line–Neutral Loads)	12.5	13.8	15.0	15.0	15.0
Output kW	11.3	12.4	13.5	13.5	13.5
Output Peak Current	155	155	155	155	155
Efficiency (Minimum)	88%	88%	88%	88%	88%
Power Dissipation (BTU/hr)	5582	5582	5582	5582	5582
DC Voltage (Supply)	192	192	192	192	192
12 kVA Model					
Output Voltage (Line Line)	200	220	240	208	220
Output Voltage (Line Neutral)	100	110	120	120	127
Input Current*	68A	62A	57A	57A	54A
Output Current	60A	55A	50A	50A	47A

Table 17. Model Specifications (Continued)

15 kVA Model					
Output kVA (Line–Line Loads)	12.0	12.0	12.0	10.4	10.4
Output kVA (Line–Neutral Loads)	12.0	12.0	12.0	12.0	12.0
Output kW	10.8	10.8	10.8	10.8	10.8
Output Peak Current	132	132	132	132	132
Efficiency (Minimum)	88%	88%	88%	88%	88%
Power Dissipation (BTU/hr)	4512	4512	4512	4512	4512
DC Voltage (Supply)	192	192	192	192	192
10 kVA Model					
Output Voltage (Line Line)	200	220	240	208	220
Output Voltage (Line Neutral)	100	110	120	120	127
Input Current*	57A	52A	48A	48A	45A
Output Current	50A	45A	42A	42A	39A
Output kVA (Line–Line Loads)	10.0	10.0	10.0	8.7	8.7
Output kVA (Line–Neutral Loads)	10.0	10.0	10.0	10.0	10.0
Output kW	9.0	9.0	9.0	9.0	9.0
Output Peak Current	110	110	110	110	110
Efficiency (Minimum)	87%	87%	87%	87%	87%
Power Dissipation (BTU/hr)	4175	4175	4175	4175	4175
DC Voltage (Supply)	192	192	192	192	192
8 kVA Model					
Output Voltage (Line Line)	200	220	240	208	220
Output Voltage (Line Neutral)	100	110	120	120	127
Input Current*	46A	42A	38A	38A	36A
Output Current	40A	36A	33A	33A	31A
Output kVA (Line–Line Loads)	8.0	8.0	8.0	6.9	6.9
Output kVA (Line–Neutral Loads)	8.0	8.0	8.0	8.0	8.0
Output kW	7.2	7.2	7.2	7.2	7.2
Output Peak Current	88	88	88	88	88
Efficiency (Minimum)	87%	87%	87%	87%	87%
Power Dissipation (BTU/hr)	3300	3300	3300	3300	3300

Table 17. Model Specifications (Continued)

15 kVA Model					
DC Voltage (Supply)	192	192	192	192	192
* Input current for the input isolation transformer is 4% higher than for the UPS.					

Table 18. Battery Specifications

Battery Type	9 Ah sealed, valve-regulated lead acid (VRLA), maintenance-free, minimum 3-year float service life at 25°C (77°F), voltage 192 Vdc (96 cells per string)
Number of Strings	Maximum of 22 strings per full configuration, including UPS batteries (4 EBM-64 cabinets or 3 EBM-96 cabinets, plus UPS batteries) UPS-32: 2 strings; UPS-64: 4 strings EBM-64: 4 strings; EBM-96: 6 strings
Battery Replacement	Must be replaced by a qualified service technician
Charger	Service configurable 0.5 34A per string, with overall maximum of 34A (limited by input current). Default: 3.4A per string
Charging	Internal battery: approximately 3 hours to 80% usable capacity at nominal line voltage after full load discharge External battery: no more than 10x discharge time to 90% usable capacity at nominal line voltage after full load discharge
Start-on-Battery	Allows start of UPS without utility input
Performance	ABM technology increases battery service life, optimizes recharge time, and provides a warning before the end of useful battery life
Protection	Extended Battery Module output protected by 100A circuit breaker

Table 19. Battery Runtimes (in Minutes) at Full Load

2-High Cabinets					
Load	32 Internal UPS Batteries	(1) EBM-64	(2) EBM-64	(3) EBM-64	(4) EBM-64
15 kVA/13.5 kW	4	23	43	65	88
12 kVA/10.8 kW	6	30	56	85	116
10 kVA/9 kW	8	37	69	106	144
8 kVA/7.2 kW	11	49	91	139	189
3-High Cabinets					
Load	64 Internal UPS Batteries	(1) EBM-96	(2) EBM-96	(3) EBM-96	
15 kVA/13.5 kW	13	43	76	113	
12 kVA/10.8 kW	18	56	101	149	
10 kVA/9 kW	22	69	124	184	

Table 19. Battery Runtimes (in Minutes) at Full Load (Continued)

8 kVA/7.2 kW	29	91	164	242
--------------	----	----	-----	-----

NOTE Battery times are approximate and vary depending on the load configuration and battery charge.

Chapter 11 Warranty

For warranty information, please refer to the Resources link on our website, www.eaton.com/9155.

EQUIPMENT REGISTRATION

Please visit www.eaton.com/pg/register to register your new Eaton UPS / Eaton UPS Accessory.

Model Number:

Serial Number:



164201553 H0