

DWG NO. 2677 G01

SH 2 REV D

| REVISIONS | | | | | | |
|-----------|----------|--|--------|-----|------|------|
| REV | CHG. NO. | DESCRIPTION | DATE | BY | CHKR | ENGR |
| D | ECN-6580 | NO CHANGES TO THIS SHEET, SEE SHEET 1. | 2-7-00 | GRD | RCM | CDP |

NOTE:
FOR INFORMATION NOT SHOWN
SEE DETAILS ON ANCHORAGE TO
STRUCTURAL SLAB

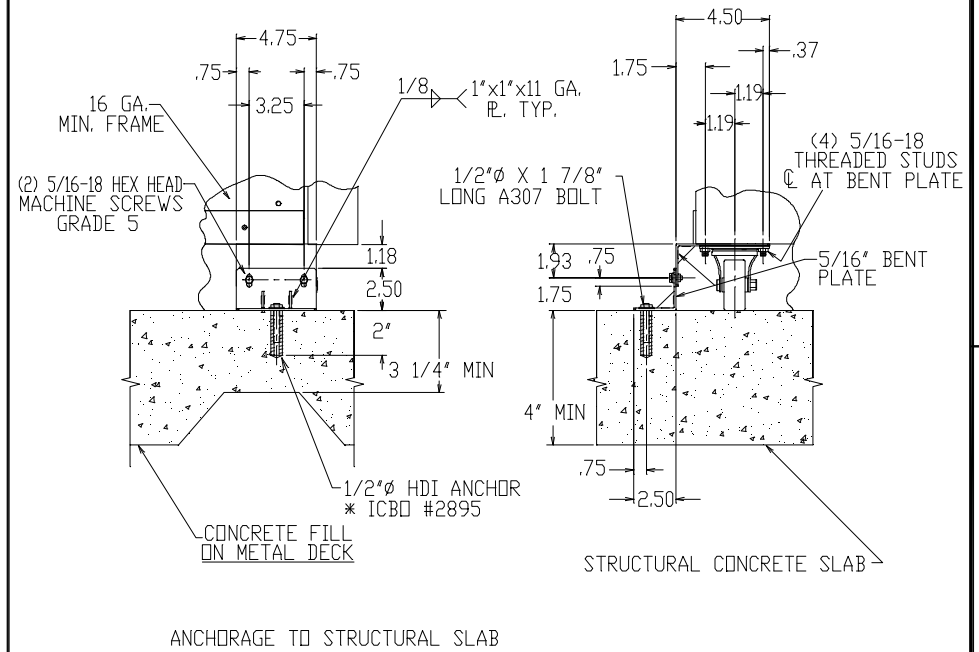
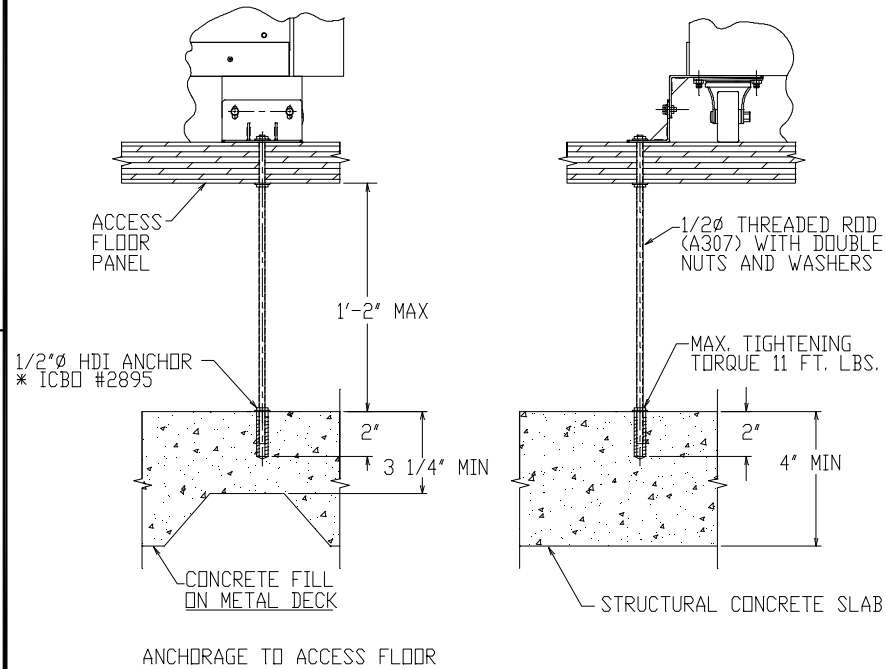

| | | | |
|--------------------------------|---|---|--|
| CAD SYSTEM AUTOCAD | DIMENSION TOLERANCE UNLESS OTHERWISE SPECIFIED DIMENSIONS ARE IN INCHES TOLERANCES ARE: INCHES ± DEC. DIM. .XX = ± .02 DEC. DIM. .XXX = ± .010 ANGLES ± 2' | APPROVED | BEST POWER A UNIT OF GENERAL SIGNAL P.O. BOX 280 NECEDAH, WI 54646 (608) 563-7200 |
| DATABASE a.c.a.d./2000-2999 | PROPRIETARY PROPRIETARY INFORMATION IN THIS DOCUMENT IS THE EXCLUSIVE PROPERTY OF BEST POWER, UNIT OF GENERAL SIGNAL AND MAY BE USED SOLELY FOR INSTALLATION OR SERVICE OF BEST POWER'S PRODUCTS. ANY OTHER USE EXPRESSLY PROHIBITED. THIS DOCUMENT MUST NOT BE REPRODUCED WITHOUT BEST POWER'S WRITTEN PERMISSION AND MUST BE RETURNED TO BEST POWER UPON DEMAND. | DRAWN BY: RJW DATE: 1-25-91 CHECKED BY: DSK DATE: 4-15-91 ENGINEER: RM DATE: 4-13-91 STANDARDS ENGINEER: _____ MANUFACTURING ENG: _____ QUALITY ASSURANCE: _____ | TITLE: FE 7KVA SEISMIC ANCHORAGE, TO FLOOR & SLAB |
| DO NOT SCALE DRAWING | | PART NO. | SCALE: NONE |
| | | SIZE B | DWG NO. 2677 G01 |
| | | REV D | SHEET 2 OF 2 |