

NOTES: UNLESS OTHERWISE SPECIFIED

1. THE ENGINEER OF RECORD SHALL VERIFY THE ADEQUACY OF THE SUPPORTING STRUCTURE INCLUDING ACCESS FLOOR PANEL TO RESIST THE GRAVITY AND LATERAL LOAD FROM THE EQUIPMENT.
2. WHEN INSTALLING DRILLED-IN ANCHORS IN EXISTING NON-PRESTRESSED REINFORCED CONCRETE, USE CARE AND CAUTION TO AVOID CUTTING OR DAMAGING THE EXISTING REINFORCING BARS. WHEN INSTALLING THEM INTO EXISTING PRESTRESSED CONCRETE (PRE- OR POST-TENSIONED), LOCATE THE PRESTRESSED TENDONS BY USING A NON-DESTRUCTIVE METHOD PRIOR TO INSTALLATION. EXERCISE EXTREME CARE AND CAUTION TO AVOID CUTTING OR DAMAGING THE TENDONS DURING INSTALLATION. MAINTAIN A MINIMUM CLEARANCE OF ONE INCH BETWEEN THE REINFORCEMENT AND THE DRILLED-IN ANCHOR.
3. ANCHORAGE DESIGNED PER CALIFORNIA CODE OF REGULATIONS, TITLE 24, PART 2, 1998 EDITION, USING TABLE 16B-0. $F_p = Z I C_p W_p$, WHERE $Z = 4$ $I = 1.5$ $C_{ph} = 1.0$ $C_{pv} = .33$.
4. TEST STANDARD: BELLCORE TECHNICAL REFERENCE TR-EOP-000063 ISSUE 3, MARCH 1988, SECTION 4.5.
5. ASSUMPTIONS: THE CONCRETE THAT THE "HDI" IS TO BE SET IN SHALL BE 3000 PSI (110 P.C.F. MINIMUM). STRUCTURAL ANGLE OR PLATE SHALL BE ASTM A-36 MINIMUM.
6. AGENCY CRITICAL PARTS. NO SUBSTITUTIONS OF MATERIALS ALLOWED.
7. TEST ANCHORS AS FOLLOWS:

TEST VALUES HARDROCK OR LIGHTWEIGHT CONCRETE						
ANCHOR DIA. (IN)	WEDGE		SLEEVE		SHELL	
	LOAD (LBS)	TORQUE (FT-LBS)	LOAD (LBS)	TORQUE (FT-LBS)	LOAD (LBS)	TORQUE (FT-LBS)
1/4	800	10	400	4	1000	-
5/16	-	-	400	5	1400	-
3/8	1100	25	700	10	1800	-
1/2	2000	50	900	20	2700	-
5/8	2300	80	1100	45	3700	-
3/4	3700	150	1400	90	5400	-
1	5800	250	-	-	-	-

- a. SHELL TYPE ANCHORS SHOULD BE TESTED AS FOLLOWS:
VISUALLY INSPECT 25% FOR FULL EXPANSION AS EVIDENCED BY THE LOCATION OF THE EXPANSION PLUG IN THE ANCHOR BODY. PLUG LOCATION OF A FULLY EXPANDED ANCHOR SHOULD BE AS RECOMMENDED BY THE MANUFACTURER, OR, IN THE ABSENCE OF SUCH RECOMMENDATION, AS DETERMINED ON THE JOB SITE FOLLOWING THE MANUFACTURER'S INSTALLATION INSTRUCTIONS, AND; PROOF LOAD 5% AS INDICATED IN THE TABLE ABOVE, BUT NOT LESS THAN THREE ANCHORS PER DAY FOR EACH DIFFERENT PERSON OR CREW INSTALLING ANCHORS, OR; TEST 50% OF THE INSTALLED ANCHORS PER 1925B.3.5.
- b. TEST EQUIPMENT IS TO BE CALIBRATED BY AN APPROVED TESTING LABORATORY IN ACCORDANCE WITH STANDARD RECOGNIZED PROCEDURES.
- c. THE FOLLOWING CRITERIA APPLY FOR THE ACCEPTANCE OF INSTALLED ANCHORS:
HYDRAULIC RAM METHOD: THE ANCHOR SHOULD HAVE NO OBSERVABLE MOVEMENT AT THE APPLICABLE TEST LOAD. FOR WEDGE AND SLEEVE TYPE ANCHORS, A PRACTICAL WAY TO DETERMINE OBSERVABLE MOVEMENT IS THAT THE WASHER UNDER THE NUT BECOMES LOOSE.
TORQUE WRENCH METHOD: THE APPLICABLE TEST TORQUE MUST BE REACHED WITHIN THE FOLLOWING LIMITS:
WEDGE OR SLEEVE TYPE: ONE-HALF (1/2) TURN OF THE NUT.
ONE-QUARTER (1/4) TURN OF THE NUT FOR THE 3/8 IN. SLEEVE ANCHOR ONLY.
- d. TESTING SHOULD OCCUR 24 HOURS MINIMUM AFTER INSTALLATION OF THE SUBJECT ANCHORS.
- e. IF ANY ANCHOR FAILS TESTING, TEST ALL ANCHORS OF THE SAME CATEGORY NOT PREVIOUSLY TESTED UNTIL TWENTY (20) CONSECUTIVE PASS, THEN RESUME THE INITIAL TESTING FREQUENCY.

REVISIONS						
REV	CHG. NO.	DESCRIPTION	DATE	BY	CHKR	ENGR
D	ECN-6680	REVISED NOTES	2-8-00	GRD	RCM	CDP

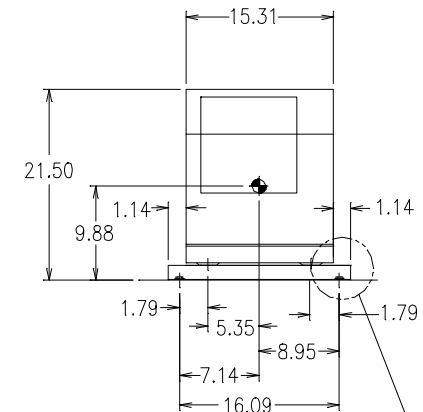
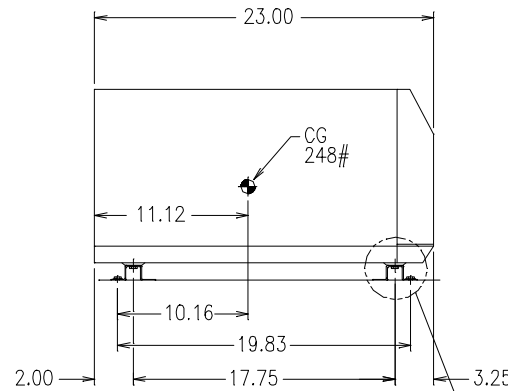
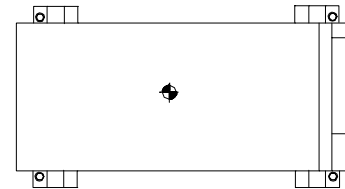

SEE SHEET 2 OF 2 FOR DETAILS

SEE SHEET 2 OF 2 FOR DETAILS

CAD SYSTEM AUTOCAD	DIMENSION TOLERANCE UNLESS OTHERWISE SPECIFIED DIMENSIONS ARE IN INCHES TOLERANCES ARE: INCHES ± DEC. DIM. .XX = ± .02 DEC. DIM. .XXX = ± .010 ANGLES ± 2'	APPROVED DRAWN BY: RJW DATE: 1-21-91 CHECKED BY: DSK DATE: 4-15-91 ENGINEER: RM DATE: 4-13-91 STANDARDS ENGINEER: _____ MANUFACTURING ENG: _____ QUALITY ASSURANCE: _____	BEST POWER A UNIT OF GENERAL SIGNAL P.O. BOX 280 NECEDAH, WI 54646 (608) 568-7200 TITLE: FE 3.1 KVA SEISMIC ANCHORAGE, CENTER OF GRAVITY
DATABASE acad/2000-2999 PROPRIETARY PROPRIETARY INFORMATION IN THIS DOCUMENT IS THE EXCLUSIVE PROPERTY OF BEST POWER, UNIT OF GENERAL SIGNAL AND MAY BE USED SOLELY FOR INSTALLATION OR SERVICE OF BEST POWER'S PRODUCTS. ANY OTHER USE EXPRESSLY PROHIBITED. THIS DOCUMENT MUST NOT BE REPRODUCED WITHOUT BEST POWER'S WRITTEN PERMISSION AND MUST BE RETURNED TO BEST POWER UPON DEMAND.	DO NOT SCALE DRAWING	PART NO.	SCALE: NONE
		SIZE: B DWG NO.: 2688 G01 REV: D	SHEET 1 OF 2