

UL924 INSTALLATION ADDENDUM

In addition to the standard install guide and manual supplied for the Powerware 9155, 9355 & 9390 series UPS. Please review this addendum; it contains a listing of specific changes made to meet all UL924 Emergency Lighting System requirements.

IMPORTANT SAFEGUARDS READ AND FOLLOW ALL SAFETY INSTRUCTIONS

When using electrical equipment, basic safety precautions should always be practiced including the following:

- Do not let power supply cords touch hot surfaces.
- Do not mount near gas or electric heaters.
- Use caution when servicing batteries. If acid is spilled or spread on the skin or eyes, flush with fresh water and contact a physician immediately.
- Equipment should be mounted in locations and at heights where it will not be subject to tampering by unauthorized personnel.
- Use if accessory equipment not recommended by the manufacturer may cause an unsafe condition.
- Do not use this equipment for other than its intended use.

SAVE THESE INSTRUCTIONS

ATTENTION: These systems are designed and tested as a set and require both the inverter (UPS) and added battery cabinet(s) as listed to supply a minimum 90 minutes of on-battery runtime in the event of a power outage for EMERGENCY EGRESS LIGHTING. These systems are designed for dedicated egress lighting only. These systems have been specifically modified to require mechanical means to shut off or turn to bypass mode (or otherwise disable) as required by Life Safety Codes within the UL924 standard. All modifications done to achieve UL924 listings do not interfere with standard accessories typically available for use with these 8-80KVA Eaton products. Examples include Seismic Kits and Options Cabinets.¹

1. This is true for some 8-30KVA 480V Models. The UL approved 20-30KVA system is used accompanied with an Options Cabinet (part number BH-KBT004-200 for 20-30KVA and BH-KBT001-200 10KVA for 277VAC) added to the line up to meet 480V requirements.

DETAILED 8KVA/7.2KW & 10KVA/9.0KW 277VAC versions

Summary of mechanical changes for inverter and matching Battery Cabinet(s)

Shield Guard over any exposed circuit breakers, the DC breaker on the back of each battery cabinet and the 2 breakers on the UPS (one DC breaker and one input breaker). This Shield Guard requires a small tool to disconnect (open) but can be switched on by a finger. Mechanical BATTERY CABLE STRAIN RELIEFs are also added on all 15KVA and below systems to DC Battery connectors which are supplied and are required to be re-installed before system activation is complete.

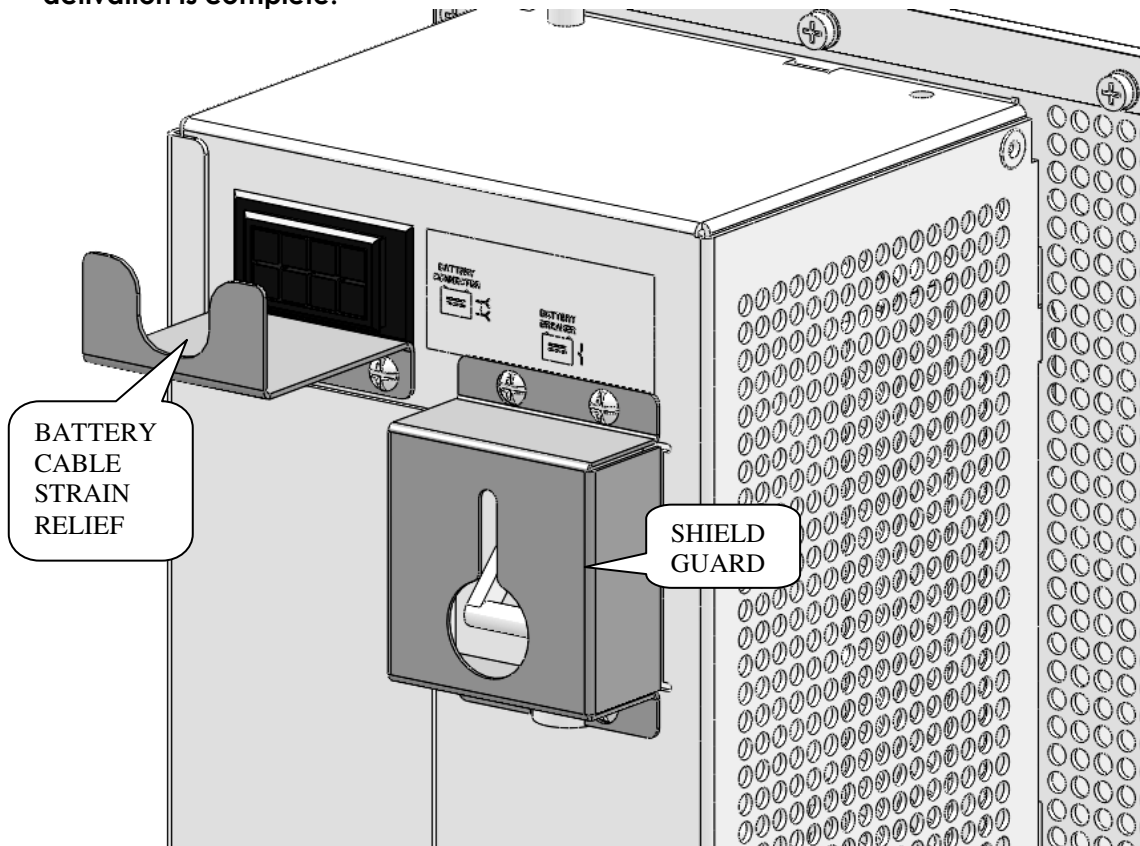

FIGURE 1

Bolts added to secure front panel (or Bezel) which otherwise exposes a means of disconnect

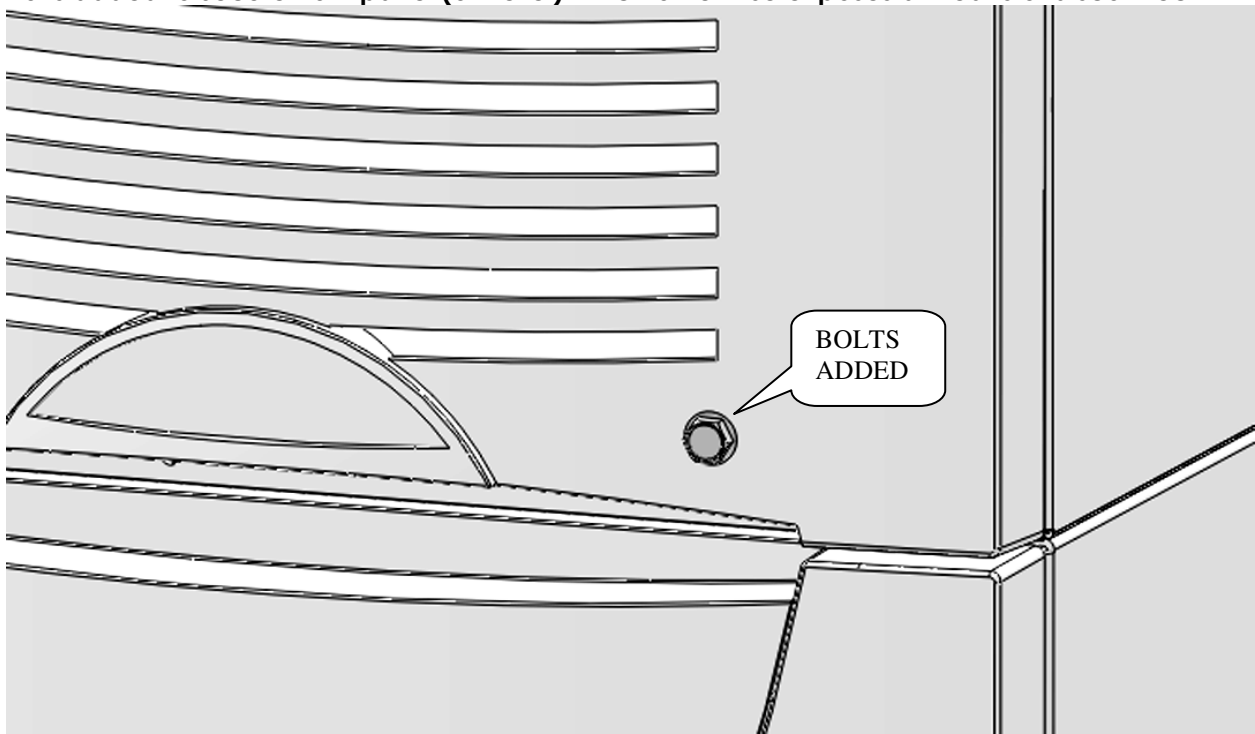

FIGURE 2

SHIELDED BRACKET installed over front panel display buttons which require a pen tip or other small tool to activate.

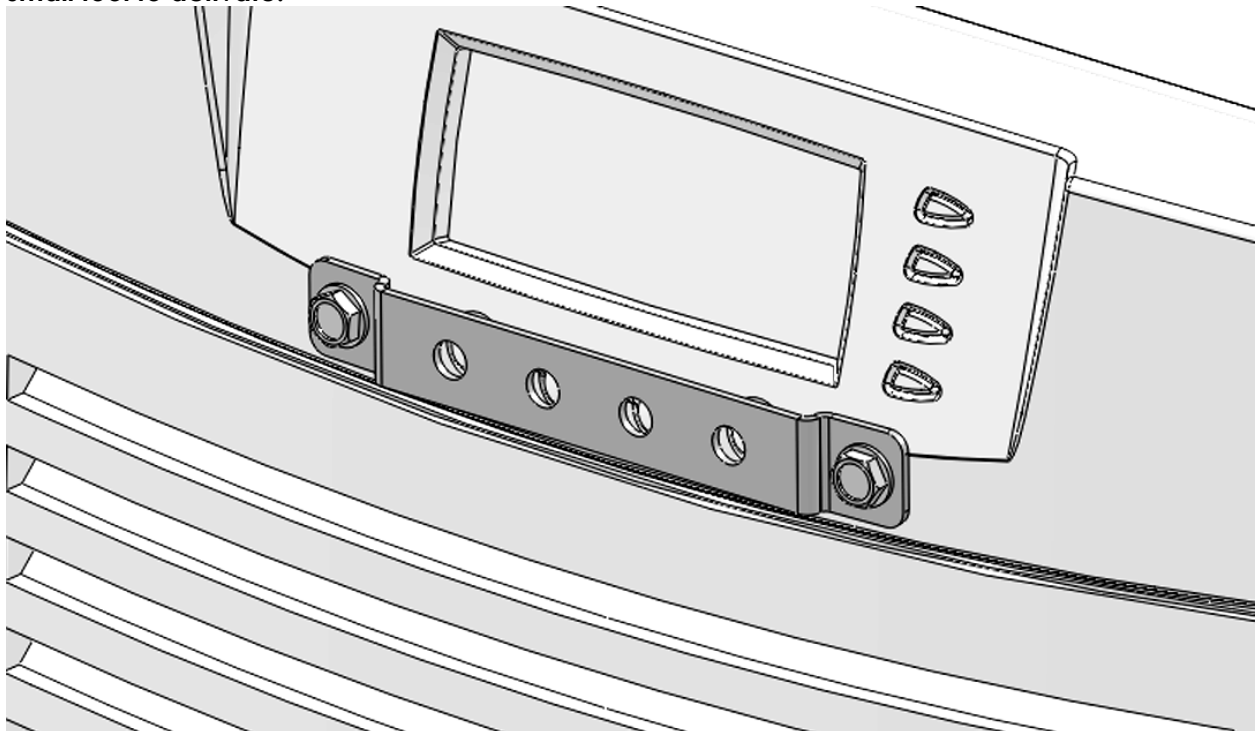

FIGURE 3

9155 Series 277VAC 1P 15KVA Chassis models approved and UL Listed UL924 configurations:

8KVA 277VAC 1PH 7.2KW* includes (1) BH-8KEL2081P-100 Controller (UPS) module and (2) BH-EBM96EL-600 and (1) BH-KBT001-200 OPTION CABINET

10KVA 277VAC 1PH 9.0KW* includes (1) BH-10KEL2081P-100 Controller (UPS) module and (2) BH-EBM96EL-600 and (1) BH-KBT001-200 OPTION CABINET

***The UL approved 8-10KVA system is used accompanied with an Options Cabinet (part number BH-KBT001-200) 9KW Max Output Rated added to the line up to meet 277V requirement. NOTE this cabinet can be used for any 1P 277VAC application up to 9KW max output.**

NOTE 1: THE PREFERRED INTERCONNECTION SCHEME FOR 9155 277VAC SYSTEMS IS TO SUPPLY THE UPPER OUTPUT TRANSFORMER IN AN L-L FASHION WITHOUT UPS OUTPUT NEUTRAL TO SUBSTANTIALLY REDUCE LEAKAGE CURRENTS.

NOTE 2:

CIRCUIT BREAKER RECOMMENDATIONS SERVICE SIDE (LOWER INPUT TRANSFORMER) FULL LOAD CURRENT 45A BREAKER 60A

CIRCUIT BREAKER RECOMMENDATIONS LOAD SIDE (UPPER INPUT TRANSFORMER) FULL LOAD CURRENT 40A BREAKER 55A

DETAILED 8KVA/5.7KW, 10KVA/6.8KW & 15KVA/10.7KW 1P 208/240VAC versions

Summary of mechanical changes for inverter and matching Battery Cabinet(s)

Shield Guard over any exposed circuit breakers, the DC breaker on the back of each battery cabinet and the 2 breakers on the UPS (one DC breaker and one input breaker). This Shield Guard requires a small tool to disconnect (open) but can be switched on by a finger.

Mechanical BATTERY CABLE STRAIN RELIEFs are also added on all 15KVA and below systems to DC Battery connectors which are supplied and are required to be re-installed before system activation is complete.

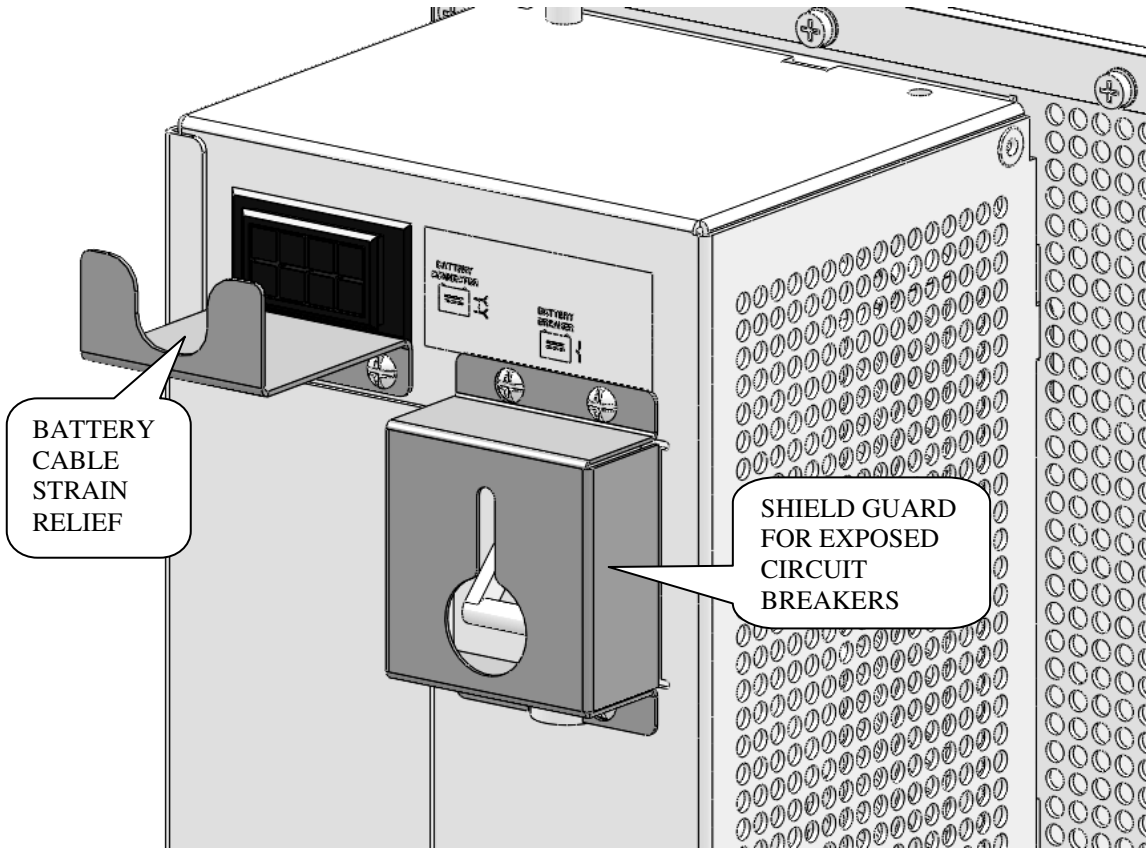

FIGURE 4

Bolts added to secure front panel (or Bezel) which otherwise exposes a means of disconnect

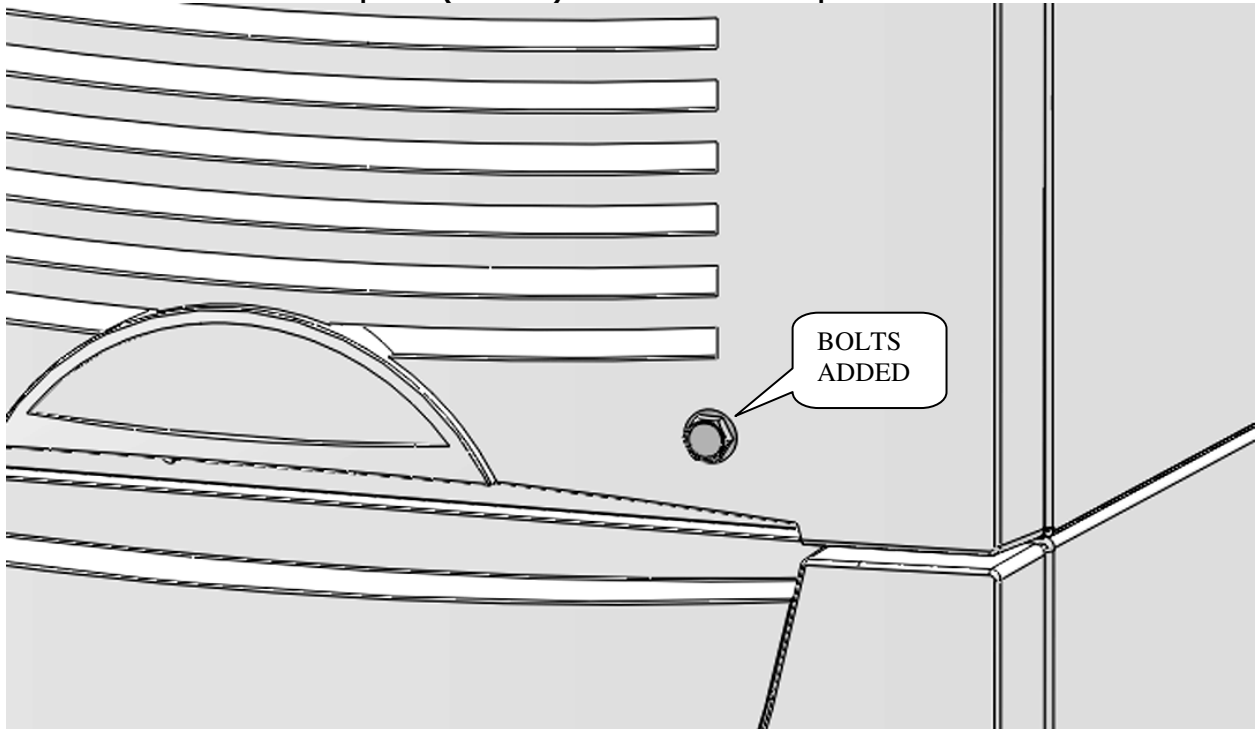

FIGURE 5

SHIELDED BRACKET installed over front panel display buttons which require a pen tip or other small tool to activate.

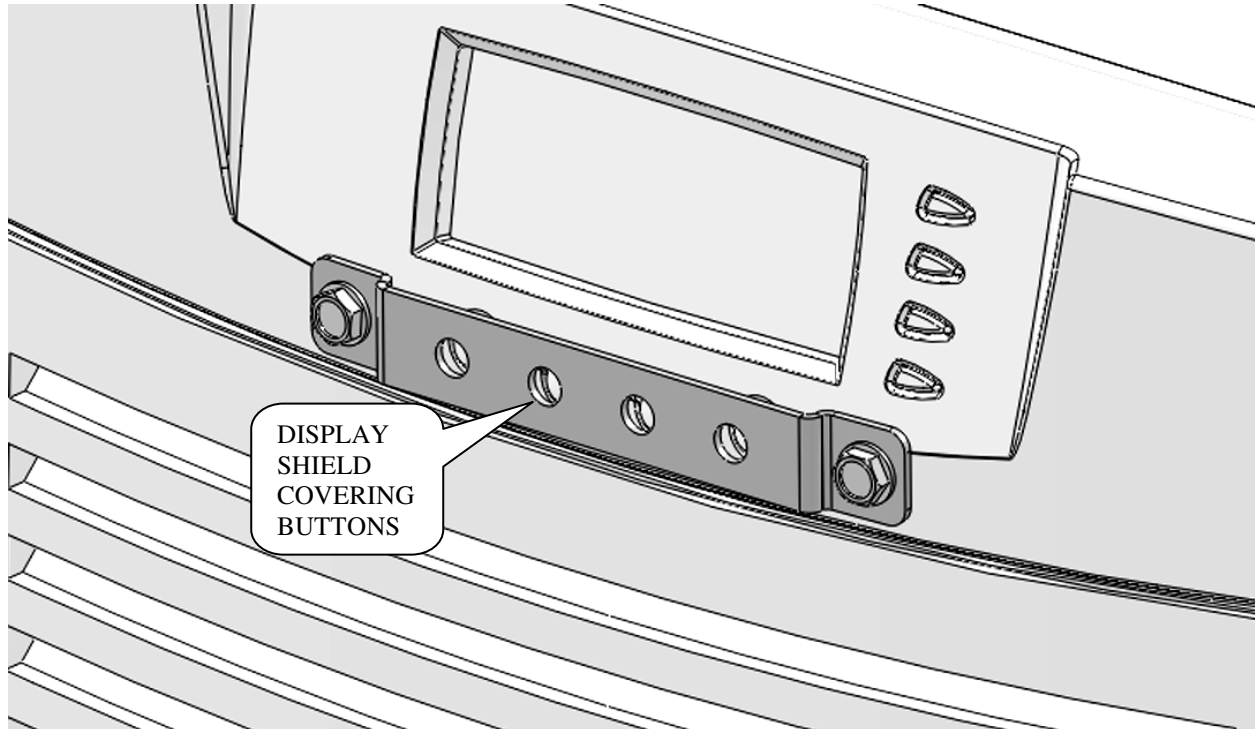

FIGURE 6

9155 Series 208/240VAC 1P 15KVA Chassis current models approved and UL Listed UL924 configurations:

8KVA 208VAC 1PH 5.7KW includes (1) BH-8KEL2081P-100 Controller (UPS) module and (1) BH-EBM96EL-600

10KVA 208VAC 1PH 6.8KW includes (1) BH-10KEL2081P-100 Controller (UPS) module and (2) BH-EBM96EL-600

15KVA 208VAC 1PH 10.7KW includes (1) BH-15KEL2081P-100 Controller (UPS) module and (3) BH-EBM96EL-600

DETAILED 8KVA/7.2KW, 10KVA/8.5KW & 15KVA/13.1KW 3P 208VAC versions

Summary of mechanical changes for inverter and matching Battery Cabinet(s)

Shield Guard over any exposed circuit breakers, the DC breaker on the back of each battery cabinet and the 2 breakers on the UPS (one DC breaker and one input breaker). This Shield Guard requires a small tool to disconnect (open) but can be switched on by a finger.

Mechanical BATTERY CABLE STRAIN RELIEFS are also added on all 15KVA and below systems to

DC Battery connectors which are supplied and are required to be re-installed before system activation is complete.

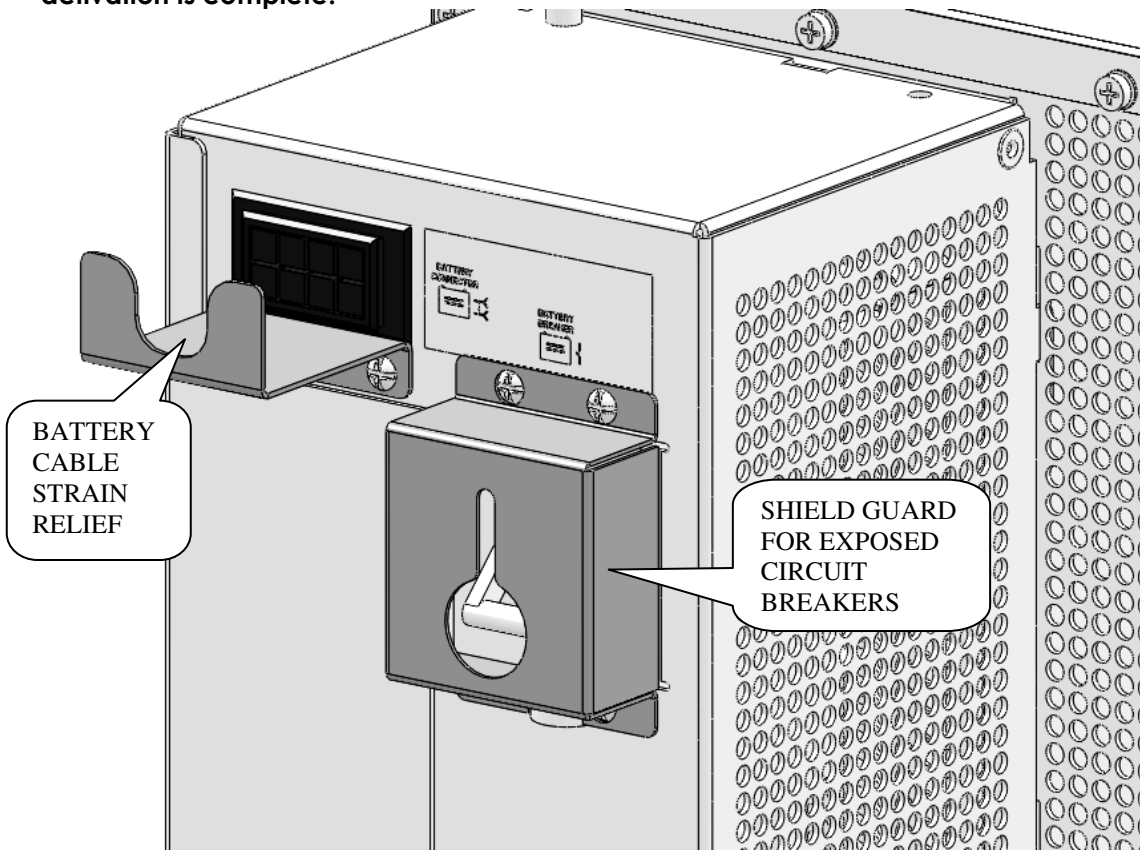

FIGURE 7

Figure 8 shows the Service Bypass Switch with the handle removed, this is another requirement based on the UL924 standard in which the handle when installed can place the system off line or without battery backup. The handle ships with the UPS and should only be used during authorized service unless installed in a restricted area (authorized access only)

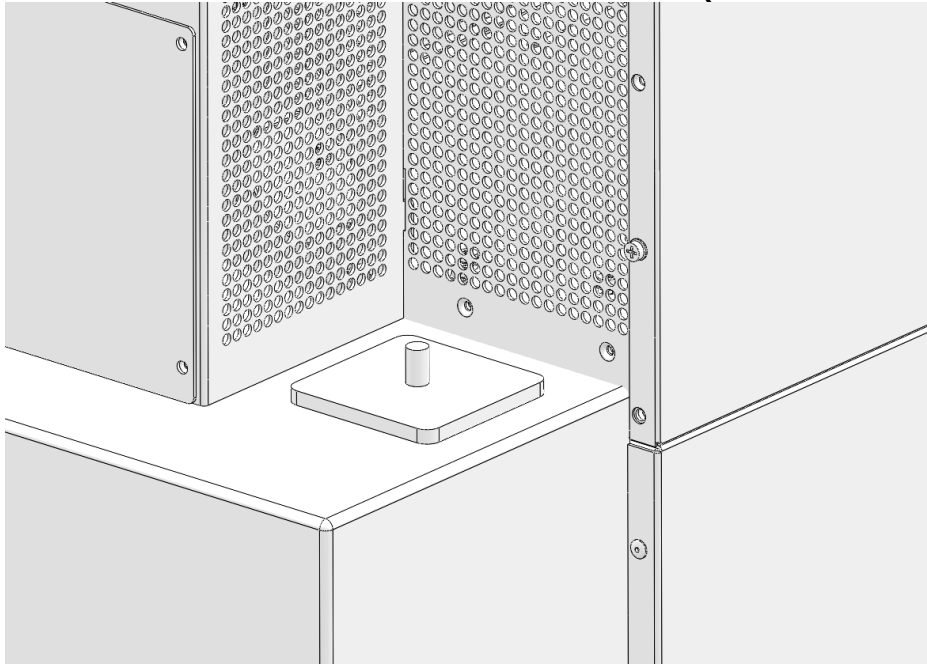

FIGURE 8

Bolts added to secure front panel (or Bezel) which otherwise exposes a means of disconnect

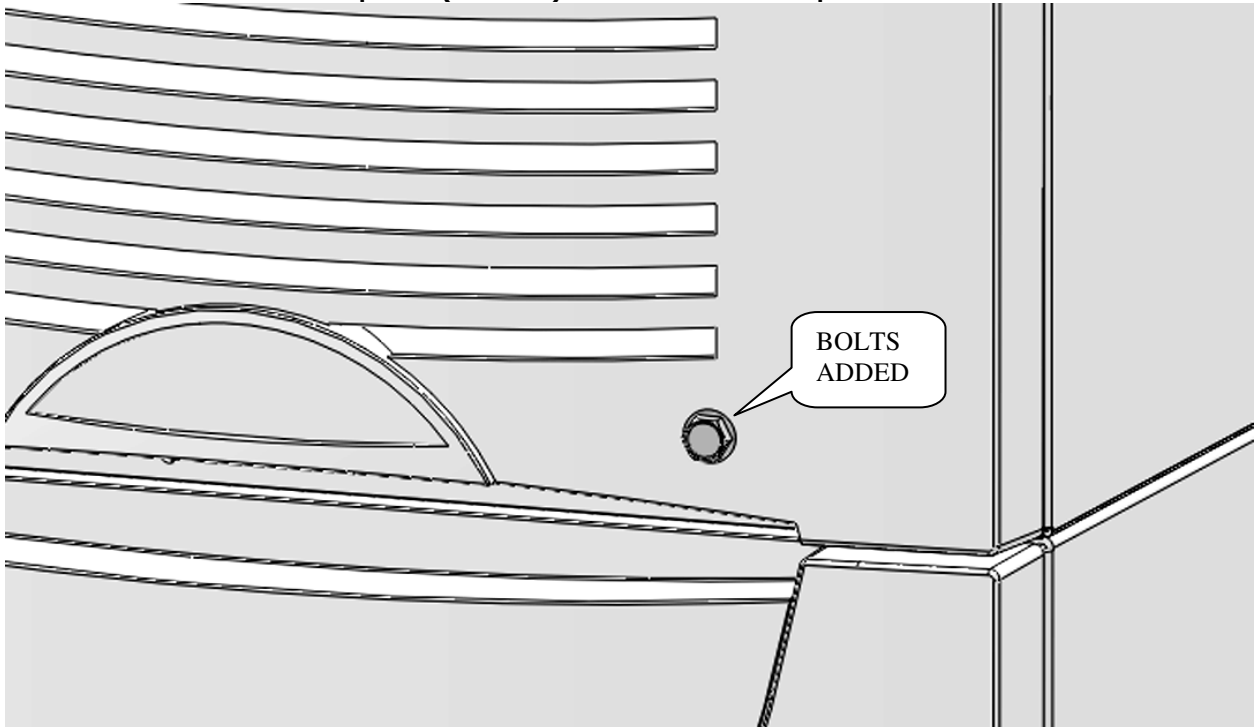

FIGURE 9

SHIELDED BRACKET installed over front panel display buttons which require a pen tip or other small tool to activate.

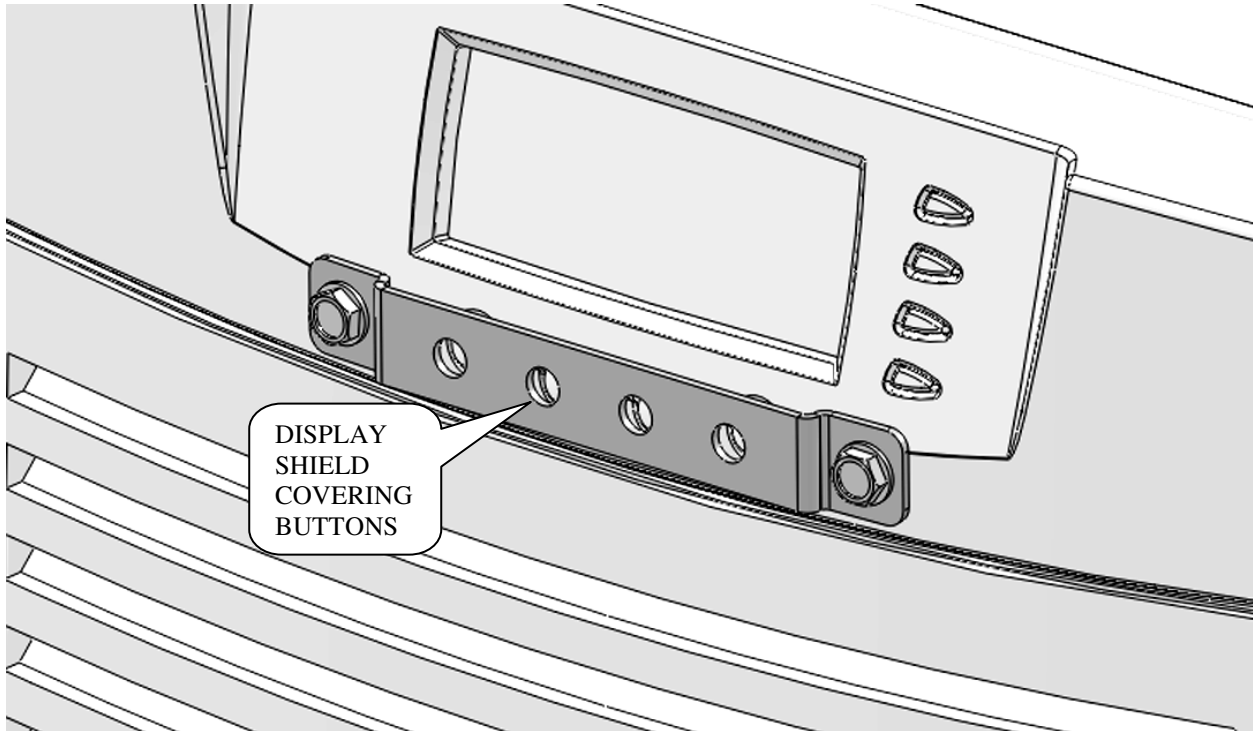

FIGURE 10

9355 Series 208VAC 3P 15KVA Chassis current models approved and UL Listed UL924 configurations:

8KVA 208VAC 3PH 7.2KW includes (1) BH-8KEL2083P-100 Controller (UPS) module and (1) BH-EBM96EL-600

10KVA 208VAC 3PH 8.5KW includes (1) BH-10KEL2083P-100 Controller (UPS) module and (2) BH-EBM96EL-600

15KVA 208VAC 3PH 13.1KW includes (1) BH-15KEL2083P-100 Controller (UPS) module and (3) BH-EBM96EL-600

DETAILED 20KVA/18KW, 30KVA/24KW & 30KVA/27KW 3P 208VAC versions

Summary of mechanical changes for inverter and matching Battery Cabinet(s)

Modifications include:

Shielded bracket over front panel display buttons, or recessed buttons, either of which require a pen tip or other small tool to activate. (See FIGURE 11)

Front panel has Bolts added (similar to all Extended Battery Cabinets) which otherwise exposes a means of disconnect via Service Bypass Switch.

9355 Series 208VAC 3P 30KVA Chassis current models approved and UL Listed UL924 configurations:

30KVA 208VAC 3PH 27KW includes (1) BH-30KEL2083P-100 Controller (UPS) module and (3) BH-EBC72EL-600

30KVA 208VAC 3PH 24KW includes (1) BH-30KEL208SF-100 Controller (UPS) module and (2) BH-EBC72EL-600

20KVA 208VAC 3PH 18KW includes (1) BH-20KEL2083P-100 Controller (UPS) module and (2) BH-EBC72EL-600

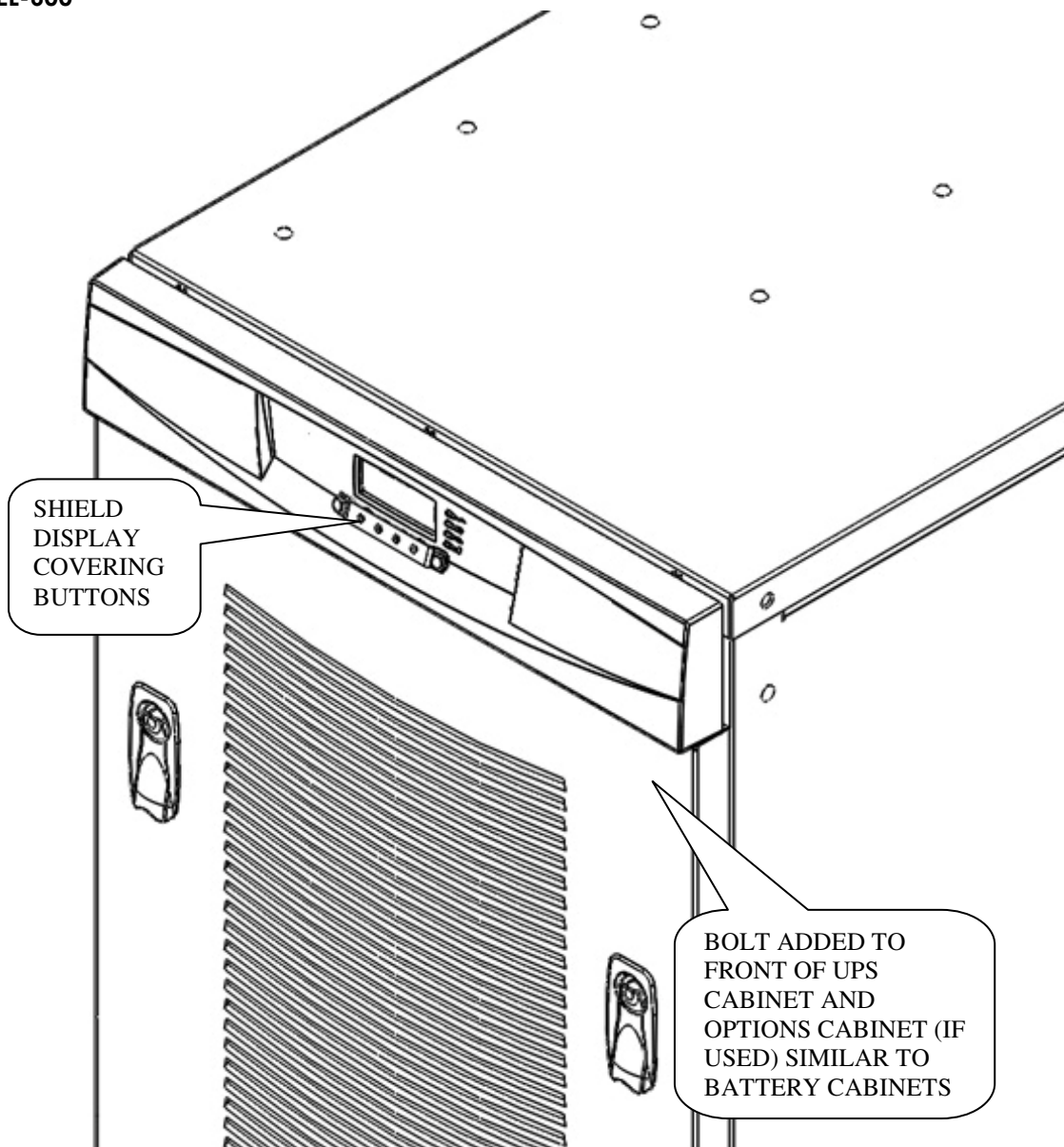

FIGURE 11

DETAILED 40KVA/36KW, 50KVA/45KW, 60KVA/54KW, & 80KVA/72KW 3P 480VAC versions

Summary of mechanical changes for inverter and matching Battery Cabinet(s)

Modifications include:

Shielded bracket over front panel display buttons, or recessed buttons, either of which require a pen tip or other small tool to activate. (See FIGURE 12)

9390 Series 480VAC 3P 80KVA Chassis current models approved and UL Listed UL924 configurations:

40KVA 480VAC 3PH 36KW includes (1) BH-40KEL480SF-100 Controller (UPS) module and (2) BH-IBC40E50EL-600

40KVA 480VAC 3PH 36KW includes (1) BH-40KEL4803P-100 Controller (UPS) module and (2) BH-IBC40E50EL-600

50KVA 480VAC 3PH 45KW includes (1) BH-50KEL4803P-100 Controller (UPS) module and (2) BH-IBC40E50EL-600

60KVA 480VAC 3PH 54KW includes (1) BH-60KEL4803P-100 Controller (UPS) module and (2) BH-IBC40E50EL-600

80KVA 480VAC 3PH 72KW includes (1) BH-80KEL4803P-100 Controller (UPS) module and (3) BH-IBC40E50EL-600

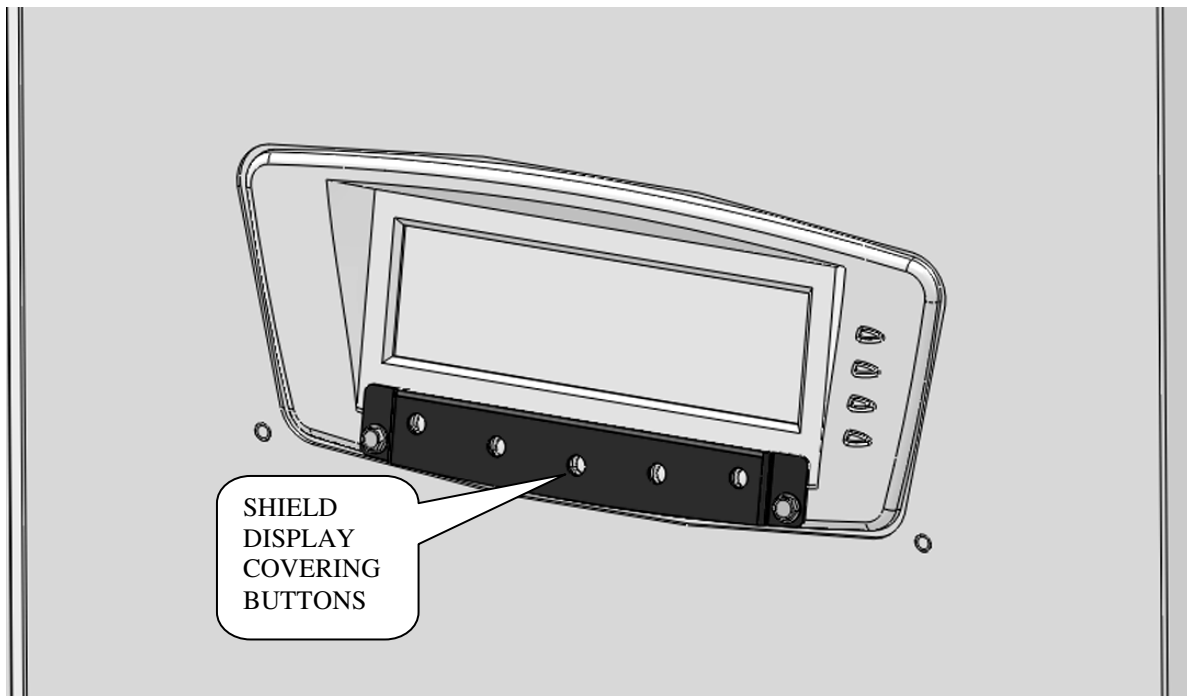

FIGURE 12