

Eaton® 9EHD UPS

20-40 kVA (380/400/415V)
Installation and Operation Manual



Powering Business Worldwide

IMPORTANT SAFETY INSTRUCTIONS SAVE THESE INSTRUCTIONS

This manual contains important instructions that you should follow during installation and maintenance of the UPS and batteries. Please read all instructions before operating the equipment and save this manual for future reference.

CONSIGNES DE SÉCURITÉ IMPORTANTES CONSERVER CES INSTRUCTIONS

Ce manuel comporte des instructions importantes que vous êtes invité à suivre lors de toute procédure d'installation et de maintenance des batteries et de l'onduleur. Veuillez consulter entièrement ces instructions avant de faire fonctionner l'équipement et conserver ce manuel afin de pouvoir vous y reporter ultérieurement

**©2016 Eaton Corporation
All Rights Reserved**

The contents of this manual are the copyright of the publisher and may not be reproduced (even extracts) unless permission granted. Every care has been taken to ensure the accuracy of the information contained in this manual, but no liability can be accepted for any errors or omission. The right to make design modifications is reserved.

Table of Contents

1	INTRODUCTION	1
1.1	UPS Standard Features	2
1.1.1	Installation Features	2
1.1.2	Control Panel	2
1.1.3	Customer Interface	2
1.1.4	Dual Input	2
1.1.5	Lift Lugs	2
1.1.6	Door Stopper	2
1.1.7	Maintenance Bypass	2
1.1.8	Advanced Battery Management	2
1.1.9	IP Protection Class	2
1.2.0	Halogen-Free Cables	2
1.2	Options and Accessories	3
1.2.1	External Battery Cabinet	3
1.2.2	Parallel System	3
1.2.3	Monitoring and Communication	3
1.2.4	Bottom Base Vibration Dampers	3
1.2.5	IP42 Kit	3
1.3	Battery System	4
1.4	Basic System Configurations	4
1.5	Using This Manual	4
1.6	Conventions Used in This Manual	4
1.7	Symbols, Controls, and Indicators	5
1.8	For More Information	5
1.9	Getting Help	5
2	SAFETY WARNINGS	6
SECTION 1—INSTALLATION		
3	UPS INSTALLATION PLAN AND UNPACKING	8
3.1	Creating an Installation Plan	8
3.2	Preparing the Site	8
3.2.1	Environmental and Installation Considerations	8
3.2.2	UPS System Power Wiring Preparation	14
3.2.3	UPS System Interface Wiring Preparation	19
3.3	Inspecting and Unpacking the UPS Cabinets	20
4	UPS SYSTEM INSTALLATION	22
4.1	Preliminary Installation Information	22
4.2	Unloading the UPS Cabinet from the Pallet	22
4.3	External Battery Cabinet Installation	26
4.4	External Power Wiring Installation	27
4.5	Installing Interface Connections	29
4.5.1	Installing Building Alarm Connections	29
4.5.2	Installing Parallel Pull Chain and CAN Control Wiring and Connections	34
4.5.3	Installing Mini-Slot Interface Connections	36
4.6	Installing a REPO Switch	37
4.7	Initial Startup	39
4.8	Completing the Installation Checklist	39

SECTION 2—OPERATION

5	UNDERSTANDING UPS OPERATION	42
5.1	UPS System Overview	42
5.2	Single UPS	43
5.2.1	Modes	43
5.2.2	Standard Normal Mode	43
5.2.3	Bypass Mode	45
5.2.4	Battery Mode	46
5.3	Single UPS Unit System Online Configurations	47
6	UPS OPERATING INSTRUCTIONS	49
6.1	UPS Controls and Indicators	49
6.1.1	Control Panel	50
6.2	Using the Control Panel	51
6.2.1	Status Indicators	51
6.2.2	System Events	52
6.2.3	Using the LCD and Pushbuttons	53
6.2.4	Using the Menu	54
6.2.5	Mimic Screen	54
6.2.6	Display Menu Operation	55
6.2.7	System Controls	57
6.3	Single UPS Operation	59
6.3.1	Starting the UPS in Standard Normal Mode (Default Mode)	59
6.3.2	Starting the UPS in Bypass Mode	59
6.3.3	Transfer from Normal to Bypass Mode	60
6.3.4	Transfer from Bypass to Normal Mode	61
6.3.5	Transfer from Normal Mode to Internal Maintenance Bypass	61
6.3.6	Transfer from Internal Maintenance Bypass to Normal Mode	62
6.3.7	UPS and Critical Load Shutdown	62
6.3.8	Charger Control	63
6.3.9	Battery Test	63
6.3.10	Using the UPS LOAD OFF Command	63
6.3.11	Using the Remote Emergency Power-off Switch	64
6.4	Multiple UPS Parallel Operation	65
6.4.1	Starting the Parallel UPS in Standard Normal Mode (Default Mode)	65
6.4.2	Starting the Parallel UPS in Bypass Mode	66
6.4.3	Transfer from Normal to Bypass Mode	66
6.4.4	Transfer from Bypass to Normal Mode	67
6.4.5	Single UPS Shutdown	67
6.4.6	Single UPS Restart	68
6.4.7	UPS and Critical Load Shutdown	68
6.4.8	Charger Control	69
6.4.9	Battery Test	69
6.4.10	Using the UPS LOAD OFF Command	70
6.4.11	Using the Remote Emergency Power-off Switch	71

7	COMMUNICATION	72
7.1	Mini-Slot Cards	72
7.2	Relay Card-MS	73
7.3	Building Alarm Monitoring	73
8	UPS MAINTENANCE	74
8.1	Important Safety Instructions	74
8.2	Performing Preventative Maintenance	75
8.2.1	DAILY Maintenance	75
8.2.2	MONTHLY Maintenance	75
8.2.3	PERIODIC Maintenance	76
8.2.4	ANNUAL Maintenance	76
8.2.5	BATTERY Maintenance	76
8.3	Installing Batteries	77
8.4	Recycling the Used Battery or UPS	77
8.5	Maintenance Training	77
9	PRODUCT SPECIFICATIONS	78
9.1	Model Numbers	78
9.2	Specifications	78

List of Figures

Figure 1-1.	Eaton 9EHD UPS (20-40 kVA)	1
Figure 3-1.	UPS Cabinet Dimensions (Front and Right Side Views)	11
Figure 3-2.	UPS Cabinet Dimensions (Top and Bottom Views)	11
Figure 3-3.	UPS Cabinet Centre of Gravity (without output transformer)	12
Figure 3-4.	UPS Cabinet Centre of Gravity (with output transformer)	13
Figure 3-5.	UPS Cabinet as Shipped on Pallet (wood container removed)	21
Figure 4-1.	Disassemble the bracket bolts that fixed on pallet in front side and rear side, total 8pcs.	23
Figure 4-2.	Take out the M20 hang bolts (4pcs)	23
Figure 4-3.	Lift cabinet with four hang bolts, move to the right installation position and put it down	24
Figure 4-4.	Assemble the bracket bolts in front side and rear side, total 8pcs	24
Figure 4-5.	Mounting Dimension of Bottom Installation	25
Figure 4-6.	Power Terminal Location (EATON 9EHD-31-40/40,30,20)	28
Figure 4-7.	Power Terminal Location (EATON 9EHD-33-40/40,30,20)	28
Figure 4-8.	Interface Terminal Locations	29
Figure 4-9.	Interface Terminal Detail	30
Figure 4-10.	Interface Terminal Locations (without transfer)	31
Figure 4-11.	Interface Terminal Detail (without transfer)	32
Figure 4-12.	Building Alarm Terminal Block Connector Assignments(without transfer)	32
Figure 4-13.	Interface Wiring Access (without transfer)	33
Figure 4-14.	Pull Chain Terminal Block Connector Assignments	34
Figure 4-15.	Parallel UPS system connections	35
Figure 4-16.	REPO Terminal Block Connector Assignments	37
Figure 4-17.	Normally-Open REPO Switch Wiring	38
Figure 4-18.	Normally-Closed REPO Switch Wiring	39
Figure 5-1.	Main Elements of the UPS System	42
Figure 5-2.	Path of Current Through the UPS in standard Normal Mode	44
Figure 5-3.	Path of Current Through the UPS in standard Bypass Mode	45
Figure 5-4.	Path of Current Through the UPS in standard Battery Mode	46
Figure 5-5.	UPS System Oneline(3 Phase Input, 3 Phase Output)	48
Figure 6-1.	UPS Controls and Indicators	49
Figure 6-2.	UPS Switches	50
Figure 6-3.	UPS Control Panel	51
Figure 6-4.	Parts of the LCD	53
Figure 6-5.	Main Menu and Mimic Screen	54
Figure 6-6.	Typical Initial Setup Screen	57
Figure 6-7.	Typical System Control Screen	58
Figure 6-8.	20-40 kVA Optional internal Maintenance Bypass switch arrangement	61
Figure 7-1.	Optional Mini-Slot Cards	72
Figure 7-2.	Relay Card-MS	73
Figure 8-1.	Air Filter Location	76

List of Tables

Table 3-1.	UPS Cabinet Weights	9
Table 3-2.	UPS Cabinet Clearances.	9
Table 3-3.	9EHD Required Clearance	9
Table 3-4.	Air Conditioning or Ventilation Requirements During Full Load Operation.	10
Table 3-5.	Input/Output Ratings and External Wiring Requirements for the Eaton 9EHD 20-40 kVA	16
Table 3-6.	UPS External Power Cable Terminations for the Eaton 9EHD 20-40kVA	17
Table 3-7.	Recommended Input Circuit Breaker Ratings.	17
Table 3-8.	Recommended Bypass Circuit Breaker, Output Circuit Breaker and Bypass Fuse Parameters Ratings.	18
Table 3-9.	Recommended DC input circuit breaker rating.	18
Table 4-1.	Building Alarm Connections	32
Table 4-2.	Pull Chain Connections.	34
Table 4-3.	REPO Connections.	37
Table 4-4.	Normally-Open REPO Wire Terminations	38
Table 4-5.	Normally-Closed REPO Wire Terminations	39
Table 6-1.	Status Indicators	51
Table 6-2.	Display Function Menu Map.	54
Table 6-3.	Display Menu Operation.	55
Table 6-4.	Command Menu Operation	58
Table 6-5.	Typical System Status Messages	58
Table 9-1.	UPS Model.	78
Table 9-2.	Environment.	78
Table 9-3.	UPS Input	79
Table 9-4.	UPS Output	79

Chapter 1 Introduction

The Eaton 9EHD 20-40 kVA uninterruptible power supply (UPS) is a true online, continuous-duty, transformer-free, double-conversion, solid-state, three-phase system, providing conditioned and uninterruptible AC power to protect the customer's load from power failures.

The Eaton 9EHD 20-40 kVA online power protection system is used to prevent loss of valuable electronic information, minimise equipment downtime, and minimise the adverse effect on production equipment due to unexpected power problems.

The Eaton 9EHD 20-40 kVA UPS continually monitors incoming electrical power and removes the surges, spikes, sags, and other irregularities that are inherent in commercial utility power. Working with a building's electrical system, the UPS system supplies clean, consistent power that sensitive electronic equipment requires for reliable operation. During brownouts, blackouts, and other power interruptions, batteries provide emergency power to safeguard operation.

The UPS is housed in a single free-standing cabinet, with safety shields behind the door for hazardous voltage protection. Figure 1-1 shows the Eaton 9EHD 20-40 kVA UPS.



NOTE 1 Startup may be performed by the customer's qualified electrical contractor for single (not parallel) UPS installations without any accessory cabinets.

NOTE 2 Startup and operational checks for parallel systems or installations with accessory cabinets must be performed by an authorised Eaton Customer Service Engineer, or the warranty terms may become void. This service is offered as part of the sales contract for the UPS. Contact an Eaton service representative in advance (usually a two-week notice is required) to reserve a preferred startup date.



Figure 1-1. Eaton 9EHD UPS (20-40 kVA)

1.1 UPS Standard Features

The UPS has many standard features that provide cost-effective and consistently reliable power protection. The descriptions in this section provide a brief overview of the UPS standard features.

1.1.1 Installation Features

Power wiring can be routed to the bottom of the cabinet with connections made to easily accessible terminals.

1.1.2 Control Panel

The control panel, located on the front of the UPS, contains a liquid crystal display (LCD) and pushbutton switches to control the operation of the UPS and to display the status of the UPS system. See Chapter 6, "UPS Operating Instructions," for additional information.

1.1.3 Customer Interface

- Building Alarm Monitoring – Up to three inputs in the UPS are available to connect the facility's alarm system contacts. Some system configurations may limit the number of inputs available. The UPS uses these inputs to monitor the building alarms in addition to the UPS status. See Chapter 7, "Communication," for additional information.
- Mini-Slot Communication Bays – Two communication bays are standard equipment. One to two optional Mini-Slot connectivity cards can be installed in the UPS module at any time. Mini-Slot cards are quickly installed at the front (behind door) of the UPS and are hot-pluggable. See Chapter 7, "Communication," for additional information.

1.1.4 Dual Input

Dual feed models are available for 9EHD UPS. To update a single feed UPS to dual feed, field update kits for dual feed can be purchased from Eaton. Connectors on dual feed models provide a separated bypass input to UPS.

1.1.5 Lift Lugs

The cabinet can be lifted with the lift lugs which are assembled on the top cover when it is carried.

1.1.6 Door Stopper

Door stopper can help to lock the door when the door is opened 105 degree.

1.1.7 Maintenance Bypass

The internal Maintenance Bypass for 20-40 kVA models consists of input, output and bypass switches used to control the AC input to the UPS the inverter output, and a Maintenance Bypass switch used to partially isolate the UPS so that a limited number of components can be serviced without interrupting power to critical systems.

1.1.8 Advanced Battery Management

A three-stage charging system increases battery service life by optimising recharge time, and protects batteries from damage due to high current charging and inverter ripple currents. Charging at high currents can overheat and damage batteries.

1.1.9 IP Protection Class

Degrees of protection provided by 9EHD 20-40kVA UPS enclosures is IP32.

1.2.0 Halogen-Free Cables

The halogen-free cable is environmentally friendly cables that do not emit toxic fumes when burned. It is particularly applicable to public places, such as subways, airports, ships, schools, hospitals and other personnel-intensive and valuable areas of property.

1.2 Options and Accessories

Contact an Eaton sales representative for information about the following options.

1.2.1 External Battery Cabinet

Battery backup protection is provided by equipping the UPS system with up to four External Battery Cabinets (EBCs) containing sealed lead-acid, maintenance-free batteries. The EBCs are housed in single, free-standing cabinets designed for line-up-and-match installation, but may be installed separate from the UPS cabinet.

1.2.2 Parallel System

A parallel UPS system with up to two UPSs can be installed to provide a parallel capacity and/or redundant system. This load sharing system provides more capacity than a single UPS, and can provide backup, depending on the load and configuration. In addition, when one UPS is taken out of service for maintenance or is not operating properly, a redundant UPS continues to supply uninterrupted power to the critical load. A Controller Area Network (CAN) Bridge provides connectivity for system metering and operational mode control.

1.2.3 Monitoring and Communication

Mini-Slot Cards – Optional Mini-Slot cards support several protocols, such as WEB/SNMP, RELAY / RS232 and Modbus. See Chapter 7, “Communication,” for additional information on monitoring and communication features.

1.2.4 Bottom Base Vibration Dampers

Vibration dampers on the bottom base can increase antiseismic capacity.

1.2.5 IP42 Kit

Add one more stainless steel net can increase the cabinet rating from IP32 to IP42 for 9EHD 20-40kVA models.

1.3 Battery System

The battery system is in an external cabinet. The battery system provides emergency short-term backup power to safeguard operation during brownouts, blackouts, and other power interruptions. The battery system is equipped with lead-acid batteries or nickel-cadmium batteries. The Battery normal voltage: 432V (216 cells) or 480V(240 cells, Default)NiCad: 384V (320 cells) or 400V (334 cells, Default) or 432V (360 cells) or 480V (400 cells)

1.4 Basic System Configurations

The following basic UPS system configurations are possible:

- Single UPS.
- Single UPS with external batteries and accessory cabinets.

The UPS system configuration can be enhanced by adding optional accessories such as a Remote Emergency Power-off (REPO) control or Mini-Slot communication cards.

1.5 Using This Manual

This manual describes how to install and operate the Eaton 9EHD 20-40 kVA. Read and understand the procedures described in this manual to ensure trouble-free installation and operation. In particular, be thoroughly familiar with the REPO procedure (see paragraph 6.3.11).

The information in this manual is divided into sections and chapters. The system, options, and accessories being installed dictate which parts of this manual should be read. At a minimum, Chapters 1 through 4 and Chapter 6 should be examined.

Read through each procedure before beginning the procedure. Perform only those procedures that apply to the UPS system being installed or operated.

1.6 Conventions Used in This Manual

This manual uses these type conventions:

- Bold type highlights important concepts in discussions, key terms in procedures, and menu options, or represents a command or option that you type or enter at a prompt.
- Italic type highlights notes and new terms where they are defined.
- Screen type represents information that appears on the screen or LCD.

Icon	Description
Note	Information notes call attention to important features or instructions.
[Keys]	Brackets are used when referring to a specific key, such as [Enter] or [Ctrl].

In this manual, the term UPS refers only to the UPS cabinet and its internal elements. The term UPS system refers to the entire power protection system – the UPS cabinet, an external battery system, and options or accessories installed.

1.7 Symbols, Controls, and Indicators

The following are examples of symbols used on the UPS or accessories to alert you to important information:



RISK OF ELECTRIC SHOCK - Observe the warning associated with the risk of electric shock symbol.



CAUTION: REFER TO OPERATOR'S MANUAL - Refer to your operator's manual for additional information, such as important operating and maintenance instructions.



This symbol indicates that you should not discard the UPS or the UPS batteries in the trash. This product contains sealed, lead-acid batteries (or nickel-cadmium batteries) and must be disposed of properly. For more information, contact your local recycling/reuse or hazardous waste centre.



This symbol indicates that you should not discard waste electrical or electronic equipment (WEEE) in the trash. For proper disposal, contact your local recycling/reuse or hazardous waste centre.

1.8 For More Information

Refer to the External Battery Cabinet Installation Manual for the following additional information:

- Installation instructions, including site preparation, planning for installation, wiring and safety information, and detailed illustrations of cabinets with dimensional and connection point drawings

Visit www.eaton.com/powerquality or contact an Eaton service representative for information on how to obtain copies of these manuals.

1.9 Getting Help

If help is needed with any of the following:

- Scheduling initial startup
- Regional locations and telephone numbers
- A question about any of the information in this manual
- A question this manual does not answer

Please call your local service representative.

Chapter 2 Safety Warnings

IMPORTANT SAFETY INSTRUCTIONS SAVE THESE INSTRUCTIONS

This manual contains important instructions that should be followed during installation and maintenance of the UPS and batteries. Read all instructions before operating the equipment and save this manual for future reference.

The UPS is designed for industrial or computer room applications, and contains safety shields behind the door and front panels. However, the UPS is a sophisticated power system and should be handled with appropriate care.

DANGER

This UPS contains LETHAL VOLTAGES. All repairs and service should be performed by AUTHORISED SERVICE PERSONNEL ONLY. There are NO USER SERVICEABLE PARTS inside the UPS.

WARNING

- The UPS is powered by its own energy source (batteries). The output terminals may carry live voltage even when the UPS is disconnected from an AC source.
 - To reduce the risk of fire or electric shock, install this UPS in a temperature and humidity controlled, indoor environment, free of conductive contaminants. Ambient temperature is recommended not to exceed 40°C(104°F). Do not operate near water or excessive humidity (95% maximum). The system is not intended for outdoor use.
 - As a result of the connected loads high leakage current is possible. Connection to earth ground is required for safety and proper product operation. Do not check UPS operation by any action that includes removal of the earth (ground) connection with loads attached.
 - Ensure all power is disconnected before performing installation or service.
 - Batteries can present a risk of electrical shock or burn from high short-circuit current. The following precautions should be observed: 1) Remove watches, rings, or other metal objects; 2) Use tools with insulated handles; 3) Do not lay tools or metal parts on top of batteries; 4) Wear rubber gloves and boots.
 - ELECTRIC ENERGY HAZARD. Do not attempt to alter any UPS or battery wiring or connectors. Attempting to alter wiring can cause injury.
 - Do not open or mutilate batteries. Released electrolyte is harmful to the skin and eyes. It may be toxic.
 - The UPS unit is not suitable for IT or corner-earthed power distribution systems.
-

CAUTION

- Installation or servicing should be performed by qualified service personnel knowledgeable of UPS and battery systems, and required precautions. Keep unauthorised personnel away from equipment. Consider all warnings, cautions, and notes before installing or servicing equipment. DO NOT DISCONNECT the batteries while the UPS is in Battery mode.
-

- See installation instructions before connecting to the supply.
 - Risk of explosion if battery is replaced by an incorrect type. Dispose of used batteries according to the instructions.
 - Replace batteries with the same number and type of batteries as originally installed with the UPS.
 - Disconnect the charging source prior to connecting or disconnecting terminals.
 - Determine if the battery is inadvertently grounded. If it is, remove the source of the ground. Contacting any part of a grounded battery can cause a risk of electric shock. An electric shock is less likely if you disconnect the grounding connection before you work on the batteries.
 - Proper disposal of batteries is required. Refer to local codes for disposal requirements.
 - Do not dispose of batteries in a fire. Batteries may explode when exposed to flame.
 - Keep the UPS door closed and front panels installed to ensure proper cooling airflow and to protect personnel from dangerous voltages inside the unit.
 - Do not install or operate the UPS system close to gas or electric heat sources.
 - The operating environment should be maintained within the parameters stated in this manual.
 - Keep surroundings uncluttered, clean, and free from excess moisture.
 - Observe all DANGER, CAUTION, and WARNING notices affixed to the inside and outside of the equipment.
-

 **CAUTION**

This product is designed for commercial and industrial applications. In a residential environment, the product may cause radio interference, in which the user may be required to take additional measures.

Chapter 3 UPS Installation Plan and Unpacking

Use the following basic sequence of steps to install the UPS:

1. Create an installation plan for the UPS system (Chapter 3).
2. Prepare your site for the UPS system (Chapter 3).
3. Inspect and unpack the UPS cabinet (Chapter 3).
4. Unload and install the UPS cabinet, and wire the system (Chapter 4).
5. Install features, accessories, or options, as applicable (Chapter 4).
6. Complete the Installation Checklist (Chapter 4).
7. Have authorised service personnel perform preliminary operational checks and start up the system.



NOTE

Startup and operational checks for parallel systems or installations with accessory cabinets must be performed by an authorised Eaton Customer Service Engineer, or the warranty terms may become void. This service is offered as part of the sales contract for the UPS. Contact an Eaton service representative in advance (usually a two-week notice is required) to reserve a preferred startup date.



CAUTION

It must be ensured that no line input source can accidentally be connected to the UPS during installation.



WARNING

- Installation may only be carried out by qualified technicians and in conformity with the applicable safety standards.
- The UPS unit is not suitable for IT or corner-earthed power distribution systems.

3.1 Creating an Installation Plan

Before installing the UPS system, read and understand how this manual applies to the system being installed. Use the procedures and illustrations in paragraph 3.2 and Chapter 4 to create a logical plan for installing the system.

3.2 Preparing the Site

For the UPS system to operate at peak efficiency, the installation site should meet the environmental parameters outlined in this manual. If the UPS is to be operated at an altitude higher than 1000m (3300 ft), contact an Eaton service representative for important information about high altitude operation. The operating environment must meet the weight, clearance, and environmental requirements specified.

3.2.1 Environmental and Installation Considerations

The UPS system installation must meet the following guidelines:

- The system must be installed on a level floor suitable for computer or electronic equipment.
- Suitable for mounting on concrete or other non-combustible surfaces only.
- The system must be installed in a temperature and humidity controlled indoor area free of conductive contaminants.

Failure to follow guidelines may void your warranty.

The UPS equipment operating environment must meet the weight requirements shown in Table 3-1 and the size requirements shown in Figure 3-1 to Figure 3-2. Dimensions are in millimetres (inches).

Table 3-1. UPS Cabinet Weights

Model	Power Rating	Weight kg(lb) without transformer		Weight kg(lb) without transformer (optional)		Remark
		Installed	Shipping	Installed	Shipping	
9EHD-31-40/20	20kVA	390(858)	465(1023)	650(1430)	725(1595)	EATON---9EHD UPS Series 31 --- three-phase input, single output. 33 ---three-phase input, three-phase output.
9EHD-33-40/20						
9EHD-31-40/30	30kVA	390(858)	465(1023)	650(1430)	725(1595)	
9EHD-33-40/30						
9EHD-31-40/40	40kVA	390(858)	465(1023)	650(1430)	725(1595)	
9EHD-33-40/40						

The UPS cabinet uses forced air cooling to regulate internal component temperature. Air inlets are in the front of the cabinet and outlets are in the top of the cabinet. Allow clearance in front of and in top of the cabinet for proper air circulation. The clearances required around the UPS cabinet are shown in Table 3-2 and Table 3-3.

Table 3-2. UPS Cabinet Clearances

From Top of Cabinet	≥500 mm(20") working space
From Front of Cabinet	≥900 mm(36") working space
From Back of Cabinet	≥50 mm(2") working space
From Right Side of Cabinet	See Table No:3-3
From Left Side of Cabinet	See Table No:3-3

The basic environmental requirements for operation of the UPS are:

- Ambient Temperature Range: 0–40°C (32–104°F)
- Recommended Operating Range: 20–25°C (68–77°F)
- Maximum Relative Humidity: 95%, noncondensing

Table 3-3. 9EHD Required Clearance

A: 9EHD Required Clearance for paralleled adjacent UPS or UPS and adjacent PDU

ambient	20kVA	30 kVA	40 kVA
25 °C			
30 °C			
35 °C	≤50	≤50	≤50
40 °C			

B: 9EHD Recommended Clearance for UPS with adjacent battery cabinet

ambient	20 kVA	30 kVA	40 kVA
25 °C	≥300	≥300	≥300

 **CAUTION**

If battery systems are located in the same room as the UPS, the battery manufacturer's environmental requirements should be followed if they are more stringent than the UPS requirements. Operating temperatures above the recommended range will result in decreased battery life and performance, and may reduce or void the battery warranty.

The UPS ventilation requirements are shown in Table 3-4.

Table 3-4. Air Conditioning or Ventilation Requirements During Full Load Operation

Model	Rating	Input/Output Voltage	Heat Rejection BTU/hr x1000 (kg-cal/hr)
Eaton 9EHD-31-40/20	20 kVA	380/220 230/230 240/240	4.62(1165)
Eaton 9EHD-33-40/20		380/380 400/400 415/415	
Eaton 9EHD-31-40/30	30 kVA	380/220 230/230 240/240	6.94(1750)
Eaton 9EHD-33-40/30		380/380 400/400 415/415	
Eaton 9EHD-31-40/40	40 kVA	380/220 230/230 240/240	9.24(2330)
Eaton 9EHD-33-40/40		380/380 400/400 415/415	

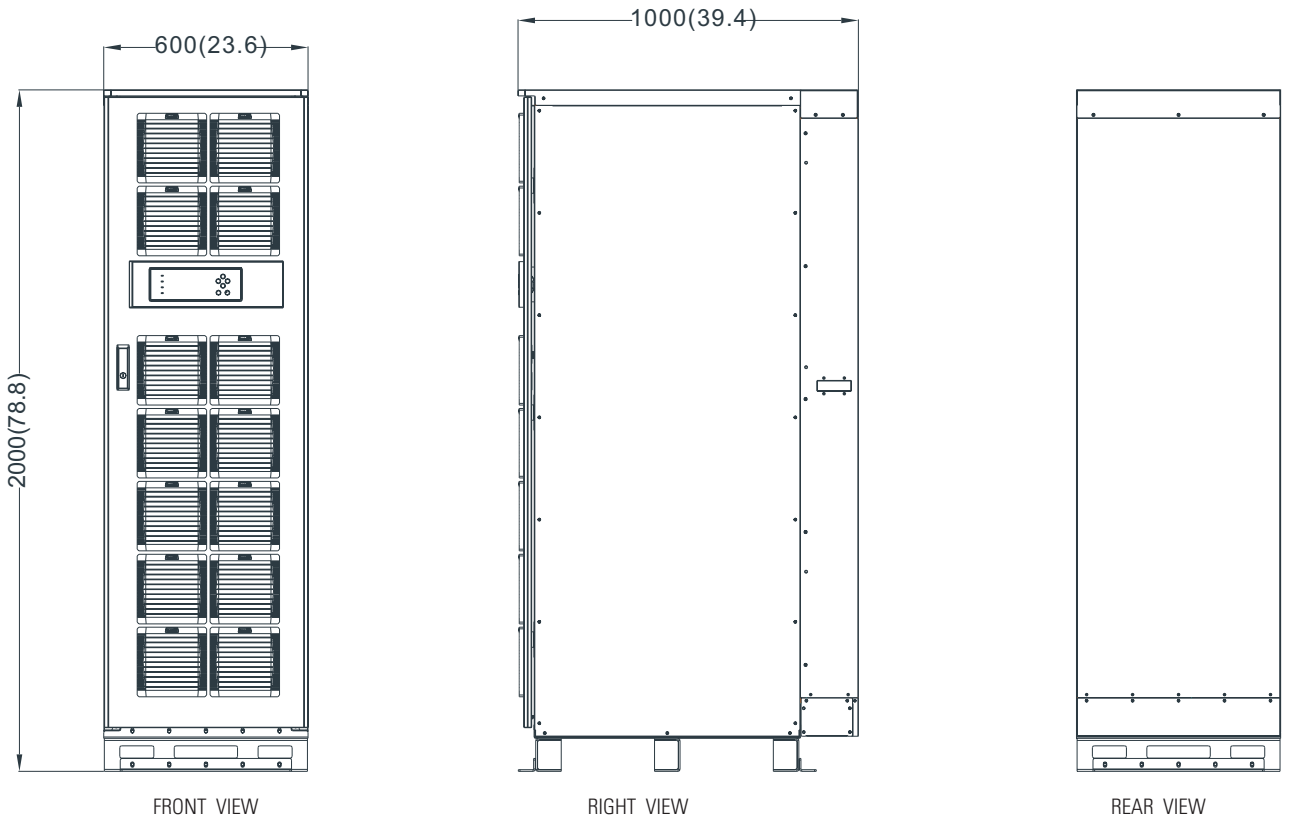

Figure 3-1. UPS Cabinet Dimensions (Front and Right Side Views)

Dimensions are in millimetres [inches]

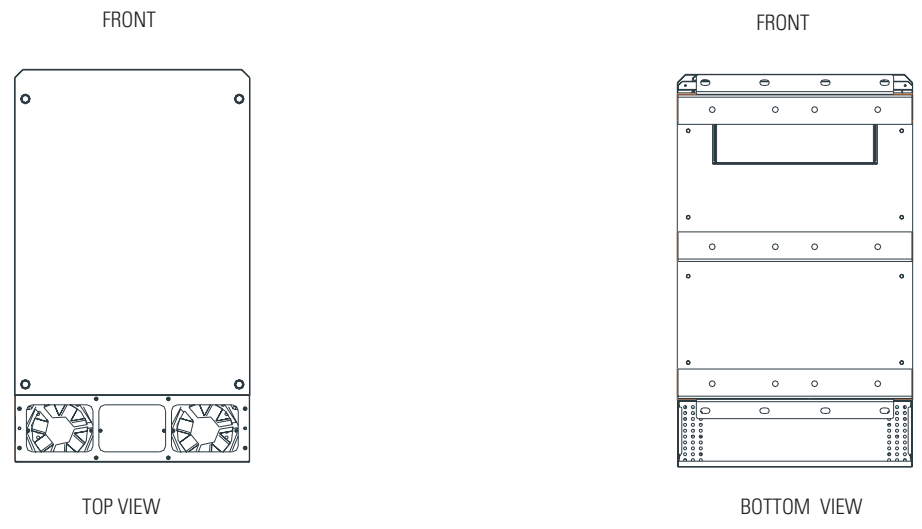

Figure 3-2. UPS Cabinet Dimensions (Top and Bottom Views)

Dimensions are in millimetres [inches]

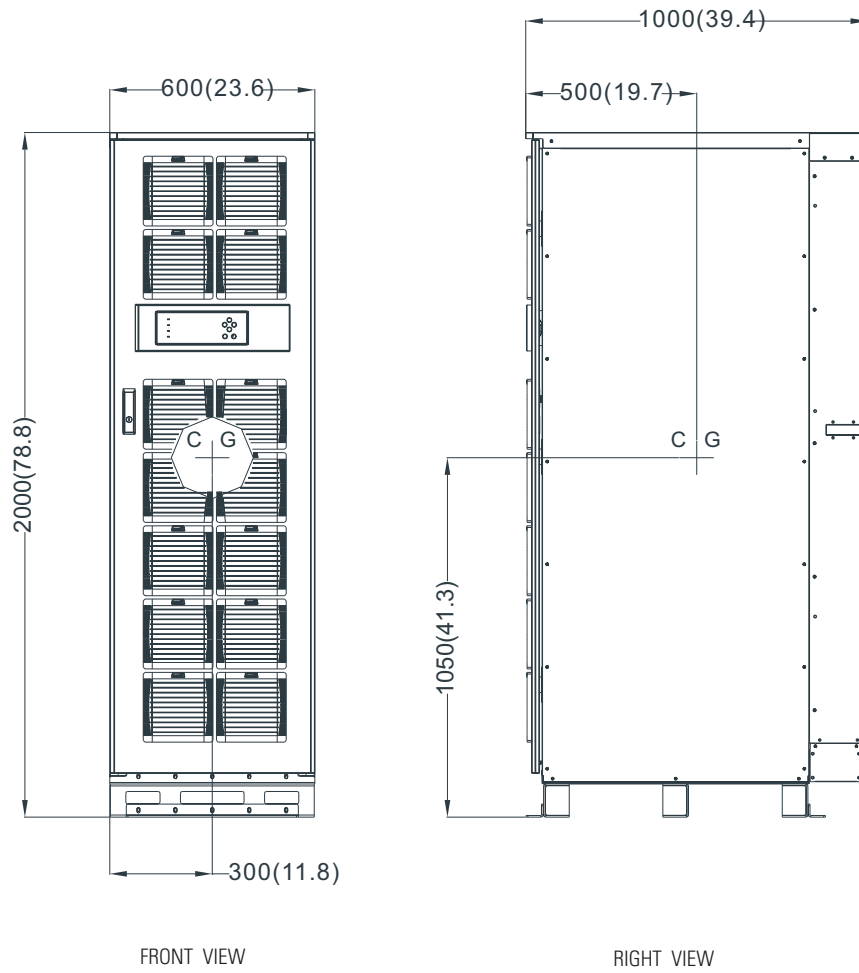

Figure 3-3. UPS Cabinet Centre of Gravity (without output transformer)

Dimensions are in millimetres [inches]

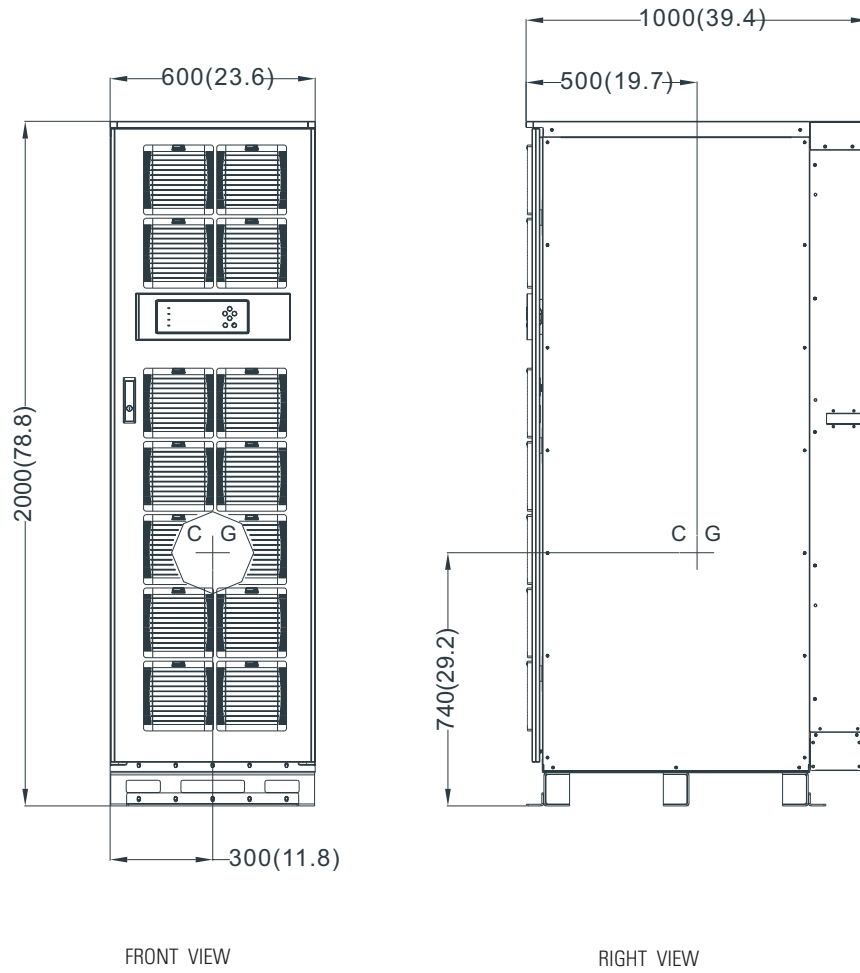

Figure 3-4. UPS Cabinet Centre of Gravity (with output transformer)

Dimensions are in millimetres [inches]

3.2.2 UPS System Power Wiring Preparation

The UPS system installation must meet the following guidelines:

- The system must be installed on a level floor suitable for computer or electronic equipment.
- The system must be installed in a temperature and humidity controlled indoor area free of conductive contaminants.

Failure to follow guidelines may void your warranty.

The UPS equipment operating environment must meet the weight requirements shown in Table 3-1 and the size requirements shown in Figure 3-1 and Figure 3-2. Dimensions are in millimetres (inches).

WARNING

- **HIGHTOUCH CURRENT EARTH CONNECTION ESSENTIAL BEFORE CONNECTING SUPPLY.**
As a result of the connected loads high leakage current is possible. Connection of the earth (ground) is required for proper product operation. Do not check UPS operation by removal of the Earth (ground) connection.
- The UPS unit is not suitable for IT and corner-earthed power distribution systems.

WARNING

- **RISK OF ELECTRIC SHOCK.** This ups receives power from more than one source - disconnection of the AC and the DC source is required to de - energise this unit before servicing. After disconnecting the utility power and the DC power, authorised service personnel should wait at least five minutes for capacitor bleedoff before attempting internal access to the UPS module.
- Backfeed protection is an internally fitted option on this device. If this is an option externally fitted backfeed contactor is not necessary to install.
- the below label should be applied on all primary power isolators installed remote from the UPS area and on external access points.

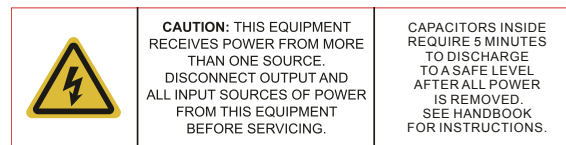
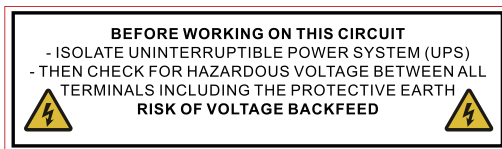

- Refer to national and local electrical codes for acceptable external wiring practices.
- To allow for future kVA upgrades, consider installing a derated UPS using wiring and external overcurrent protection breakers sized for a fully rated UPS.
- For external wiring, use 90°C copper wire. Wire sizes listed in Table 3-5 are for copper wiring only. If wire is run in an ambient temperature greater than 30°C, higher temperature wire and/or larger size wire may be necessary. Wire sizes are based on using the specified breakers.
- Material and labour for external wiring requirements are to be supplied by designated personnel.
- If installing an external maintenance bypass, all feeds to the UPS including the Rectifier Input Breaker (RIB) (if installed) must have a service disconnect independent of the maintenance bypass power path. Most maintenance bypass solutions provide UPS input feeds derived from but isolated from the maintenance bypass power path. If the maintenance bypass solution being installed does not provide such functionality, DO NOT use a single feeder breaker to supply both the UPS and the maintenance bypass.

- The bypass feed into this equipment uses four wires (three line conductors and neutral conductor), plus grounding conductor (protective earthing conductor) . The rectifier feed into this equipment uses four wires (three line conductors and neutral conductor), plus grounding conductor (protective earthing conductor). The phases must be symmetrical about ground (from a Wye/Star source) for proper equipment operation.
- Parallel UPS input wiring size requirements and output wiring size requirements from the UPSs to the Tie Cabinet are the same as those for single systems.
- This device is not equipped with its own mains separation device. It is , therefore, essential that the customer install such a device at the installation site near the UPS.
- Install a proper three-pole overcurrent disconnect device before connecting to the UPS, the disconnect device shall disconnect simultaneously all line conductors of the AC MAINS SUPPLY.
- Do not disconnect neutral, neutral required for system operation.
- If a disconnect device interrupts the neutral conductor, it shall simultaneously interrupt all line conductors.
- When single-phase current exceeds 100A, switches of protective atmosphere should be equipped with arc-control device.
- The UPS requires an input neutral connection. Ensure that an input neutral is connected prior to energising the UPS. If a 4 pole Automatic Transfer Switch is installed upstream of the UPS it must work with a break before make transition with a minimum transfer time of 50ms.

Figure 4-6 and Figure 4-7 show the location of the UPS power cable terminals.

Table 3-5. Input/Output Ratings and External Wiring Requirements for the Eaton 9EHD 20-40 kVA

Basic Unit Rating	cross-sections	Units	Rating 50/60 Hz		
		kVA kW	20 18	30 27	40 36
Input and Output Voltage		Volts	400/230	400/230	400/230
A: AC Input to UPS Rectifier Full load current plus battery recharge current (3) Phases, (1) Neutral, (1) Ground		Amps	41	56	70
Conductor Size (Phase A, B, C and N)	min	mm ²	4×1	6×1	10×1
	max	mm ²	16×1	25×1	35×1
B: AC Input to UPS Bypass (Five Wire, Dual-Feed) Full Load Current (3) Phases, (1) Neutral		Amps	29	43	58
Conductor Size (Phase A, B, C)	min	mm ²	2.5×1	4×1	6×1
	max	mm ²	10×1	16×1	25×1
Conductor Size (N) (linear load)	min	mm ²	6×1	10×1	16×1
	max	mm ²	25×1	35×1	50×1
C: DC Input from External Battery (432 Vdc) (1) Positive, (1) Negative		Total Amps	46	69	92
Conductor Size	min	mm ²	6×1	10×1	16×1
	max	mm ²	25×1	35×1	50×1
D: AC Output to Critical Load (Five Wire) Full Load Current (3) Phases, (1) Neutral		Amps	29	43	58
Conductor Size (Phase A, B, C)	min	mm ²	2.5×1	4×1	6×1
	max	mm ²	10×1	16×1	25×1
Conductor Size (N) (linear load)	min	mm ²	6×1	10×1	16×1
	max	mm ²	25×1	35×1	50×1
Protective bonding conductors			1.0times		
Protective earthing conductors	min	mm ²	6×1	10×1	16×1
Neutral (N) (Mains/Load):(Non-linear load)			1.7 times		
Backfeed protection device			Clearance distance:>=2.0 mm Break time <=15s		

NOTE Callout letters A, B, C, and D map to Figure 5-5.

 CAUTION

External overcurrent protection is not provided by this product, but is required by codes. Refer to table 3-5 for wiring requirements. If an input/output lockable disconnect is required, it is to be supplied by the user.

Table 3-6. UPS External Power Cable Terminations for the Eaton 9EHD 20-40 kVA

Terminal Function	Terminal	Function	Bus landing	Tightening Torque Nm (lb in)	Screw Size and Type
AC Input to UPS Rectifier	L1	Phase A	M8 bolt mounting	8 (70)	50.24 mm ² (M8). Hex
	L2	Phase B	M8 bolt mounting	8 (70)	50.24 mm ² (M8). Hex
	L3	Phase C	M8 bolt mounting	8 (70)	50.24 mm ² (M8). Hex
	N	Neutral	M8 bolt mounting	8 (70)	50.24 mm ² (M8). Hex
AC Input to Bypass	L1	Phase A	M8 bolt mounting	8 (70)	50.24 mm ² (M8). Hex
	L2	Phase B	M8 bolt mounting	8 (70)	50.24 mm ² (M8). Hex
	L3	Phase C	M8 bolt mounting	8 (70)	50.24 mm ² (M8). Hex
	N	Neutral	M8 bolt mounting	8 (70)	50.24 mm ² (M8). Hex
AC Output to Critical Load	L1	Phase A	M8 bolt mounting	8 (70)	50.24 mm ² (M8). Hex
	L2	Phase B	M8 bolt mounting	8 (70)	50.24 mm ² (M8). Hex
	L3	Phase C	M8 bolt mounting	8 (70)	50.24 mm ² (M8). Hex
	N	Neutral	M8 bolt mounting	8 (70)	50.24 mm ² (M8). Hex
DC Input from External Battery	+	Battery (+)	M10 bolt mounting	10(86)	78.52 mm ² (M10). Hex
	-	Battery (-)	M10 bolt mounting	10(86)	78.52 mm ² (M10). Hex
Customer Ground	Ground	Ground	M8 bolt mounting	12 (106)	50.24 mm ² (M8). Hex
Heater (Optional)	L	Ground(jerry)	M6 bolt mounting	3(26)	28.26 mm ² (M6). Hex
	N	Ground(jerry)	M6 bolt mounting	3(26)	28.26 mm ² (M6). Hex

NOTE Callout letters A, B, C, and D map to Figure 5-5.

Table 3-7. Recommended Input Circuit Breaker Ratings

UPS Model	Circuit Breaker Rating		
	Load Derating	400V	I2T A2Sec
Eaton 9EHD-31-40/20	80% Derated	51A	>2116
Eaton 9EHD-33-40/20	100% Rating	41A	
Eaton 9EHD-31-40/30	80% Derated	70A	>3969
Eaton 9EHD-33-40/30	100% Rating	56A	
Eaton 9EHD-31-40/40	80% Derated	88A	>6241
Eaton 9EHD-33-40/40	100% Rating	70A	



CAUTION

To reduce the risk of fire, connect only to a circuit provided with maximum input circuit breaker current ratings from Table 3-7 in accordance with local regulations.

The line-to-line unbalanced output capability of the UPS is limited only by the full load per phase current values for AC output to critical load shown in Table 3-5. The recommended line-to-line load unbalance is 50% or less.

Readily accessible disconnect devices (Bypass and output overcurrent protection and bypass disconnect breaker) are to be supplied by the customer. Table 3-8 lists the recommended rating for bypass and output circuit breakers.

Table 3-8. Recommended Bypass Circuit Breaker, Output Circuit Breaker and Bypass Fuse Parameters Ratings

UPS Model	Circuit Breaker Rating		Fuse Parameters	
	Load Derating	400V	Current/Min	I ² T A ² Sec/Max
Eaton 9EHD-33-40/20	80% Derated	36A	40A	10200
	100% Rating	29A		
Eaton 9EHD-33-40/30	80% Derated	54A	63A	10200
	100% Rating	43A		
Eaton 9EHD-33-40/40	80% Derated	73A	80A	20400
	100% Rating	58A		

There is no DC disconnect device within the UPS. A battery disconnect breaker is recommended, And may be required by local codes when batteries are remotely located. The battery disconnect breaker should be installed between the battery and the UPS

External DC input overcurrent protection and disconnect breaker for the remote battery location is to be provided by the user. Table 3-9 lists the maximum rating for continuous-duty rated circuit breakers satisfying the criteria for both.

Table 3-9. Recommended DC input circuit breaker rating

UPS Model	Circuit Breaker Rating	
	Load Derating	Rated battery voltage (480V, 40 sections)
Eaton 9EHD-33-40/20	80% Derated	58A
	100% Rating	46A
Eaton 9EHD-33-40/30	80% Derated	86A
	100% Rating	69A
Eaton 9EHD-33-40/40	80% Derated	115A
	100% Rating	92A

Battery voltage is computed at 2 volts per cell. Rated battery current is computed at 2 volts per cell. The battery wiring used between the battery and the UPS should not allow a voltage drop of more than 1% of nominal DC voltage at rated battery current. If the conductors used for DC input from the battery cabinets to the UPS are those provided by the UPS manufacturer, and the UPS and battery cabinets are manufactured by the same supplier, then it is acceptable if they do not meet the noted minimum conductor sizes.

3.2.3 UPS System Interface Wiring Preparation

Control wiring for features and options should be connected at the customer interface terminal blocks located inside the UPS.

 **WARNING**

Do not directly connect contactor contacts to the mains related circuits. Reinforced insulation is required before connecting to the mains.

Read and understand the following notes while planning and performing the installation:

- Interface wiring should be rated for 24V, 1A minimum.
- For interface wiring from 30V to 600V, the wire should be rated for 600V, 1A minimum.
- Because of the REPO and building alarm wiring route in the UPS cabinet, the wire should be rated for a minimum of 300V.
- Use twisted-pair wires for each input and return or common.
- All interface wiring and conduit is to be supplied by the customer.
- When installing external interface wiring between a REPO or building alarm and the UPS interface terminals, conduit must be installed between each device and the UPS cabinet.
- If using the power terminal wiring channel, keep interface wiring separate from power wiring or use shielded wire.
- If using conduit, install the interface wiring in separate conduit from the power wiring.
- All building alarm inputs require an isolated normally-open contact or switch (rated at 24 Vdc, 20 mA minimum) connected between the alarm input and common terminal. All control wiring and switch contacts are customer-supplied.
- LAN and telephone drops for use with Mini-Slot connectivity cards must be supplied by the customer.
- The REPO feature opens all contactors in the UPS cabinet and isolates power from your critical load. Local electrical codes may also require tripping upstream protective devices to the UPS.
- The REPO switch must be a latching-type switch not tied to any other circuits.
- A jumper wire must be connected between pins 3 and 4 on the REPO terminal block if using a normally-closed REPO switch.
- REPO wiring should be a minimum of 0.5~2.0 mm².
- The REPO switch wiring must be in accordance with local regulations.
- The maximum distance between the REPO and the UPS cannot exceed 150 metres (500 feet).

3.3 Inspecting and Unpacking the UPS Cabinets

The cabinet is shipped bolted to a wooden pallet and protected with an outer wood container.

 **WARNING**

The UPS cabinet is heavy (see Table 3-1). If unpacking and unloading instructions are not closely followed, the cabinet may tip and cause serious injury.

1. Carefully inspect the outer packaging for evidence of damage during transit.

 **CAUTION**

Do not install a damaged cabinet. Report any damage to the carrier and contact an Eaton service representative immediately.



NOTE

For the following step, verify that the forklift or pallet jack is rated to handle the weight of the cabinet (see Table 3-1 for cabinet weight).

2. Use a forklift or pallet jack to move the packaged cabinet to the installation site, or as close as possible, before unpacking. If possible, move the cabinets using the pallet. Insert the forklift or pallet jack forks between the supports on the bottom of the pallet (see Figure 3-3 and Figure 3-4 for the UPS cabinet centre of gravity measurements).

 **CAUTION**

Do not tilt the UPS cabinets more than 10° from vertical or the cabinets may tip over.

3. Set the pallet on a firm, level surface, allowing a minimum clearance of 3m (10 ft) on each side for removing the cabinet from the pallet.
4. Remove the protective wood container from the cabinet:



NOTE

For the following steps, use pincer type pliers or a large flat blade screw driver to straighten the securing tabs.

- a. Straighten the tabs securing the top panel of the wooden container to the side panels of the container.
 - b. Remove the top panel and retain for later use as a ramp in unloading the cabinet from the pallet.
 - c. Straighten the tabs securing the side panels of the container to the front and back panels of the container.
 - d. Remove the side panels.
 - e. Straighten the tabs securing the front and back panels of the container to the bottom of the container.
 - f. Remove the front and back panels.
5. Remove the inner protective packaging. Retain the parts kit box, ramp brackets, and ramp extension packed at the top of the cabinet.
 6. Recycle the remainder of the outer shipping container and the inner protective packaging in a responsible manner.

7. Inspect the contents for any evidence of physical damage, and compare each item with the Bill of Lading. If damage has occurred or shortages are evident, contact an Eaton service representative immediately to determine the extent of the damage and its impact on further installation.

**NOTE**

While waiting for installation, protect the unpacked cabinet from moisture, dust, and other harmful contaminants. Failure to store and protect the UPS properly may void your warranty.

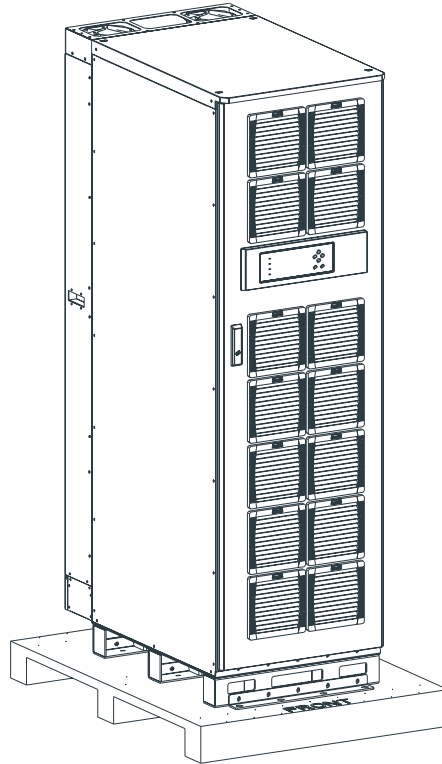

Figure 3-5. UPS Cabinet as Shipped on Pallet (wood container removed)

Chapter 4 UPS System Installation

4.1 Preliminary Installation Information



WARNING

Installation should be performed only by qualified personnel. See installation instructions before connecting to the supply.

Refer to the following while installing the UPS system:

- Chapter 3 for cabinet dimensions, equipment weight, wiring and terminal data, and installation notes.
- Do not tilt the cabinets more than $\pm 10^\circ$ during installation.
- If perforated floor tiles are required for ventilation, place them in front of the UPS.
- The UPS unit is not suitable for IT or corner-earthed power distribution systems.
- Suitable for mounting non-combustible surfaces only

4.2 Unloading the UPS Cabinet from the Pallet

The UPS Cabinet is bolted to a wooden pallet supported by wood skids. To remove the pallet:



WARNING

The UPS cabinet is heavy (see Table 3-1). If unpacking and unloading instructions are not closely followed, the cabinet may tip and cause serious injury.



CAUTION

- Do not tilt cabinet more than 10° from vertical.
 - Lift the cabinets only with a forklift or damage may occur.
-



NOTE

For the following steps, verify that the forklift or pallet jack is rated to handle the weight of the cabinet (see Table 3-1 for cabinet weight).

If not already accomplished, use a forklift or pallet jack to move the UPS cabinet to the installation area, or as close as possible, before unloading from the pallet. Insert the forklift or pallet jack forks between the supports on the bottom of the pallet (see Figure 3-9 through Figure 3-11 for the UPS cabinet centre of gravity measurements)

WARNING

Do not stand directly in front of the pallet while unloading the cabinet. If unloading instructions are not closely followed, the cabinet may cause serious injury.

See Figure 4-1 through Figure 4-5 for the UPS installation. Lift the cabinet only with a forklift or a crane, and make sure the load of them is enough.

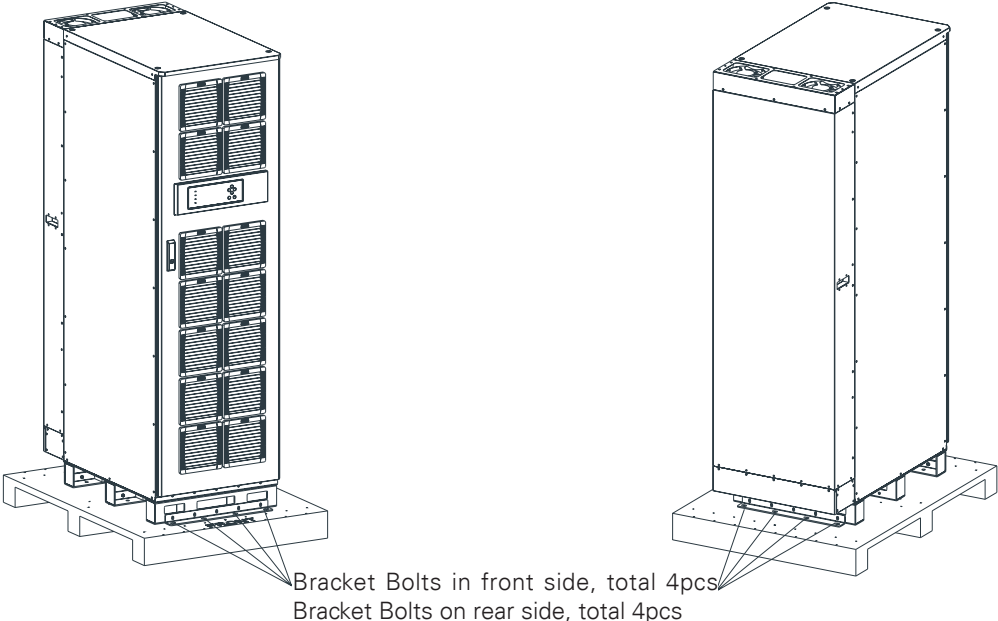

Warning: Do not throw away the bolts, and the size is M12*40

Figure 4-1. Disassemble the bracket bolts that fixed on pallet in front side and rear side, total 8pcs

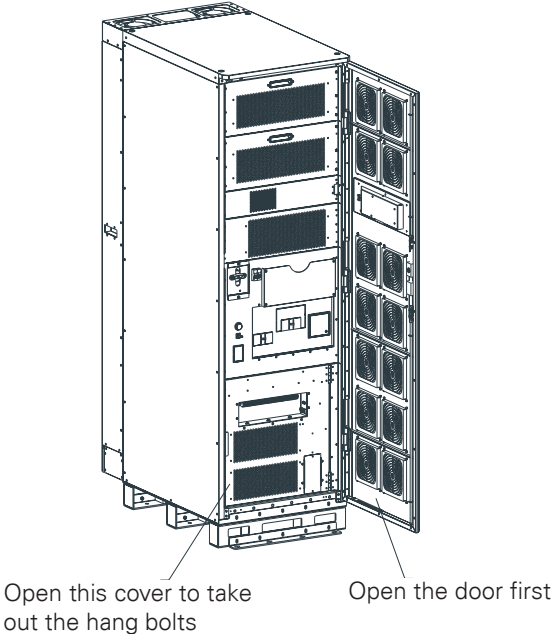
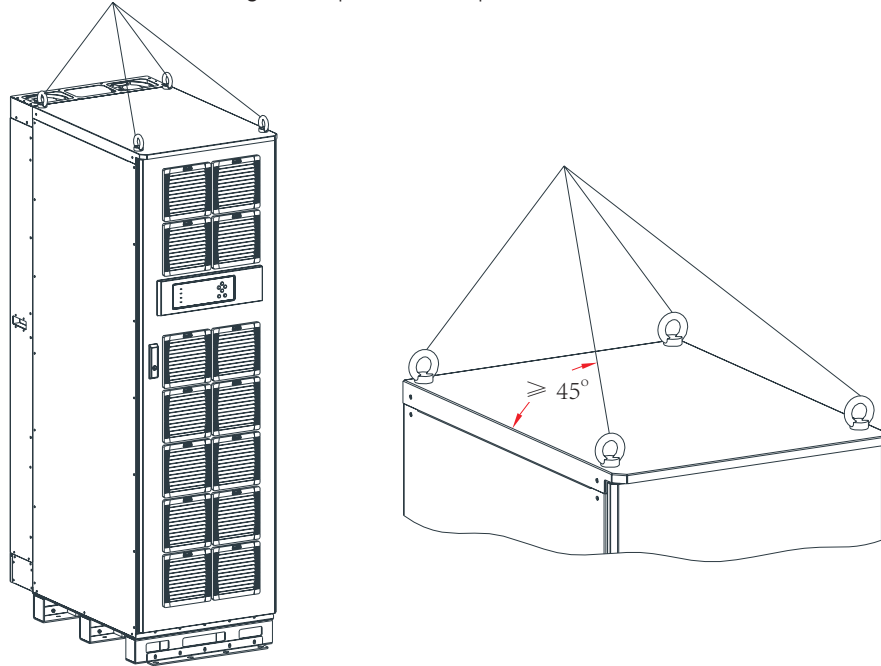

Figure 4-2. Take out the M20 hang bolts (4pcs)

Assemble hang bolts(4pcs) at the top of the cabinet.



Warning:

1. Hang bolts should be screw tightened.
2. Must use all the four hand bolts to lift the cabinet.
3. Make sure the load of sling and crane is larger than 2 tons.
4. The angle between the sling and the level must greater than or equal to 45 degrees.
5. These machine is too heavy, make sure the ground is able to withstand.

Figure 4-3. Lift cabinet with four hang bolts, move to the right installation position and put it down

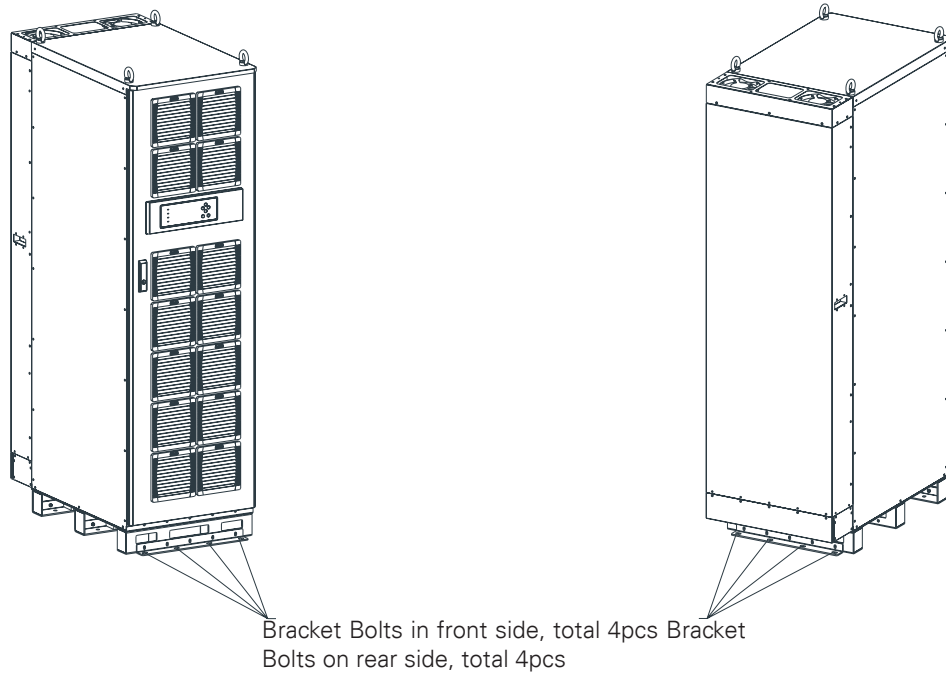

Bracket Bolts in front side, total 4pcs
Bracket Bolts on rear side, total 4pcs

Figure 4-4. Assemble the bracket bolts in front side and rear side, total 8pcs

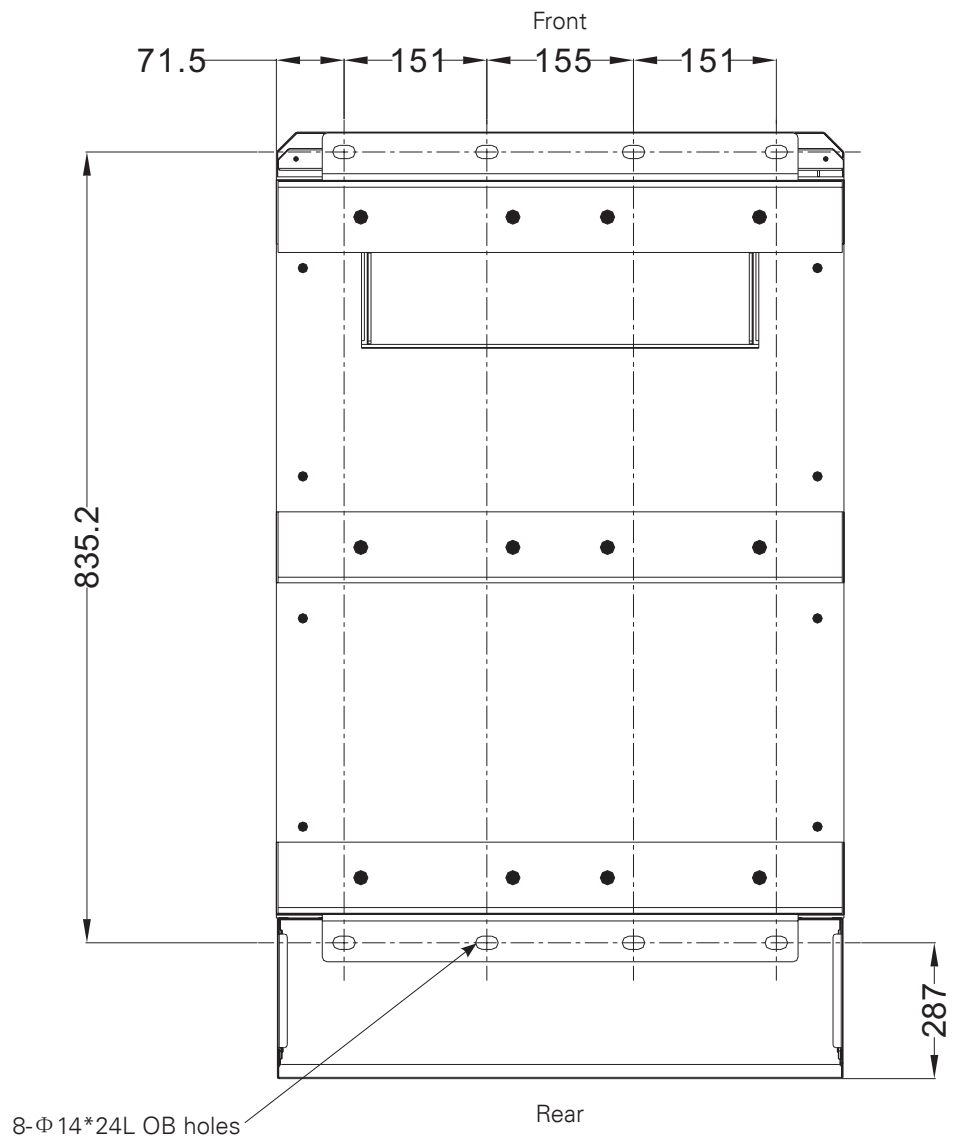

Figure 4-5. Mounting Dimension of Bottom Installation

4.3 External Battery Cabinet Installation

Before connecting the external battery, please read the notice and warning label on the battery cabinet.

 **WARNING**

- In the event of malfunction, the battery cabinet chassis or battery cabinet frames may become live.
- Special care should be taken when working with the battery cabinet associated with the equipment. Ensure the battery number is suited to the setting of the battery charging voltage before installing the battery. When the battery cabinet is connected the overall voltage exceeds nominal voltage. It is very important to ensure that the batteries are installed separately, in a dedicated battery cabinet.
- Battery back-up time do not exceed one hour, if the battery setting shall be exceeded one hour, consult to the professional personnel.

 **CAUTION**

- The most common battery type used in UPS installations is the valve regulated battery. Valve regulated cells are not sealed. The amount of gas given off is less than for flooded cells, but when planning the battery installation, allowance must be made for adequate ventilation and heat dissipation. Valve regulated cells are not completely maintenance-free. They must be kept clean and their connections checked periodically to ensure they are tight, and that there is no evidence of corrosion. It is inevitable that the batteries will lose charge during transportation and storage; before attempting to carry out an autonomy test, ensure that the batteries are fully charged as this may take several hours. Cell performance typically improves after a few discharge/recharge cycles.
- The requirements of the EC directives are satisfied when battery cabinet are used with original accessories. If alternative batteries are used, you must ensure that the applicable EC directives are met and declare conformity.

Connect the battery cabinet as follows:

Turn off the UPS.

Check all the external battery breakers are open.

Connect PE first.

Connect the battery cabinet(s) with cables sized according to cable cross section and protective device specification to terminals + (positive pole) and - (negative pole).

Refer to instructions provided with the battery cabinet or by vendor.

 **WARNING**

ENSURE CORRECT POLARITY!

4.4 External Power Wiring Installation



NOTE

Without accessory cabinets, conduit and wiring enter from the bottom of the UPS conduit landing plate. With accessory cabinets, wiring can be installed between the UPS and accessory cabinets by using conduit or by routing wiring through the power terminal cover base wiring channels.

To install wiring:

1. Route the wiring to the UPS terminal blocks in the UPS. Figure 4-6 and Figure 4-7 for wiring access information and terminal locations.
2. Ground the UPS according to local and/or national electrical wiring codes by routing and connecting the ground wire to the input ground lug. See Figure 4-6 and Figure 4-7 for UPS terminal locations. For a detailed view of the UPS ground terminals, see Figure 4-6 and Figure 4-7.
3. Connect phase A, B, C, and Neutral rectifier input power wiring from the utility source to the rectifier input and neutral terminals. See paragraph 3.2.2 for wiring and termination requirements. For a detailed view of the UPS terminal block, see Figure 4-6 and Figure 4-7.
4. Bypass input power wiring from the utility source to the bypass input terminals and neutral terminals. See paragraph 3.2.2 for wiring and termination requirements.

Attention: Mains input N and Bypass input N are connected together inside UPS

For single feed installation, jumpers the input and bypass terminals (L1-L1, L2- L2, L3- L3) must be installed.

The jumpers are in the cable kit which is supplied with the UPS.

For a detailed view of the UPS terminal block, see Figure 4-6 and Figure 4-7.

5. Connect phase A, B, and C, and Neutral power wiring from output terminals and neutral terminals to the critical load. See paragraph 3.2.2 for wiring and termination requirements. For a detailed view of the UPS terminal block, see Figure 4-6 and Figure 4-7.
6. If wiring interface connections, proceed to paragraph 4.5.



WARNING

- HIGHTOUCH CURRENT. EARTH CONNECTION ESSENTIAL BEFORE CONNECTING SUPPLY. As a result of the connected loads high leakage current is possible. Connection of the earth (ground) is required for proper product operation. Do not check UPS operation by removal of the Earth (ground) connection.
- If there's input ATS for dual source input or generator as UPS input source, the ATS should be 3-pole; if with 4-pole ATS, the N interruption time should be less than 50ms.
- BAT+/BAT- are terminals connected to the battery cabinet, Battery+ polarity should use red cable, battery- polarity should use black or blue cable.
- This device may not be fitted with an optional internal mains disconnection device. If not fitted, it is essential that the customer install such a device at the installation site near the UPS.
- Input neutral line should be directly connected to input "N" terminal of UPS wire connection terminal bay without AC input idle-run.
- There are protective earthing terminals within the UPS for mains supply, load supply and battery. The battery cabinet earth protection can be connected either to the UPS or to a common earthing terminal outside the UPS.

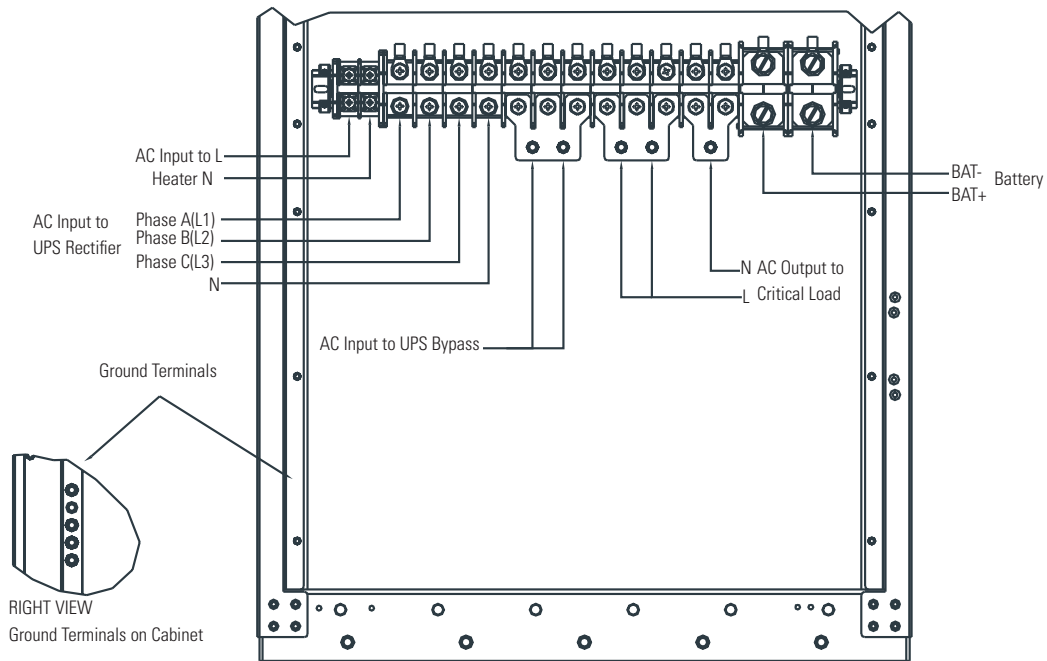

Figure 4-6. Power Terminal Location (EATON 9EHD-31-40/40,30,20)

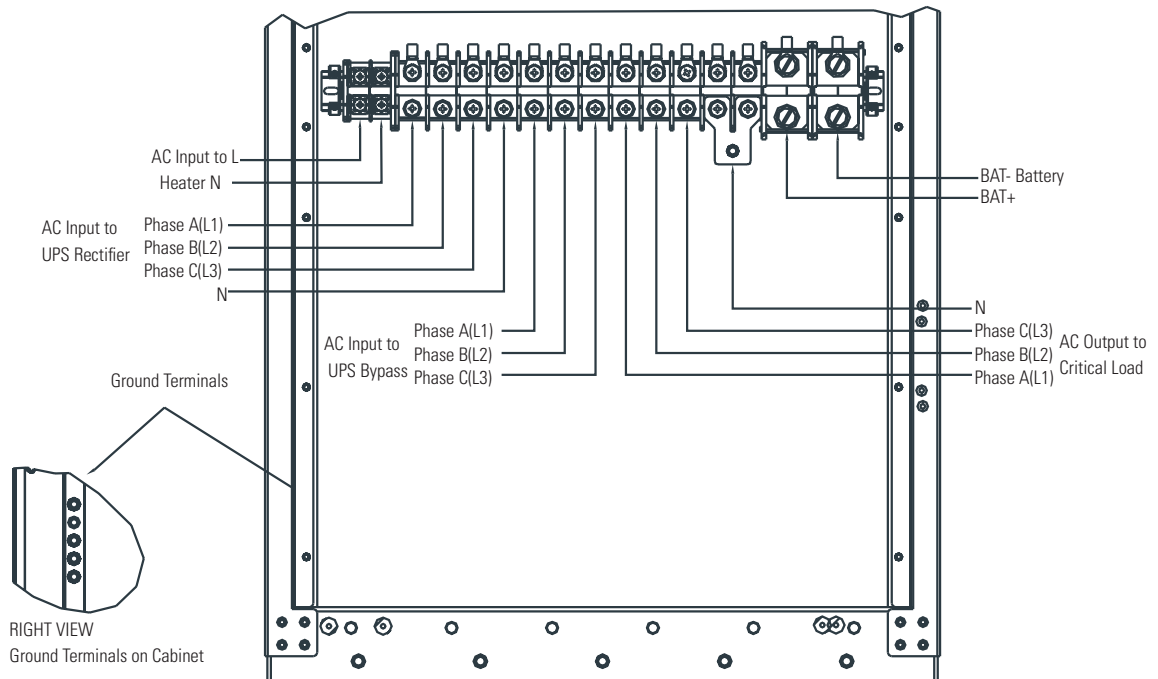

Figure 4-7. Power Terminal Location (EATON 9EHD-33-40/40,30,20)

4.5 Installing Interface Connections

4.5.1 Installing Building Alarm Connections

To install wiring:

1. Verify the UPS system is turned off and all power sources are removed. See Chapter 6, "UPS Operating Instructions", for shutdown instructions.
2. To locate the appropriate terminals and review the wiring and termination requirements, see paragraph 3.2.3, Table 4-1, Figure 4-8 and Figure 4-12.
3. Interface cables can enter the UPS via bottom hole see Figure 4-8 and Figure 4-13.
4. Connect the building alarm interface wiring as shown in Table 4-1 and Figure 4-12.
5. If wiring parallel connections, proceed to paragraph 4.5.2; if wiring Mini-Slot connections, proceed to paragraph 4.5.3;

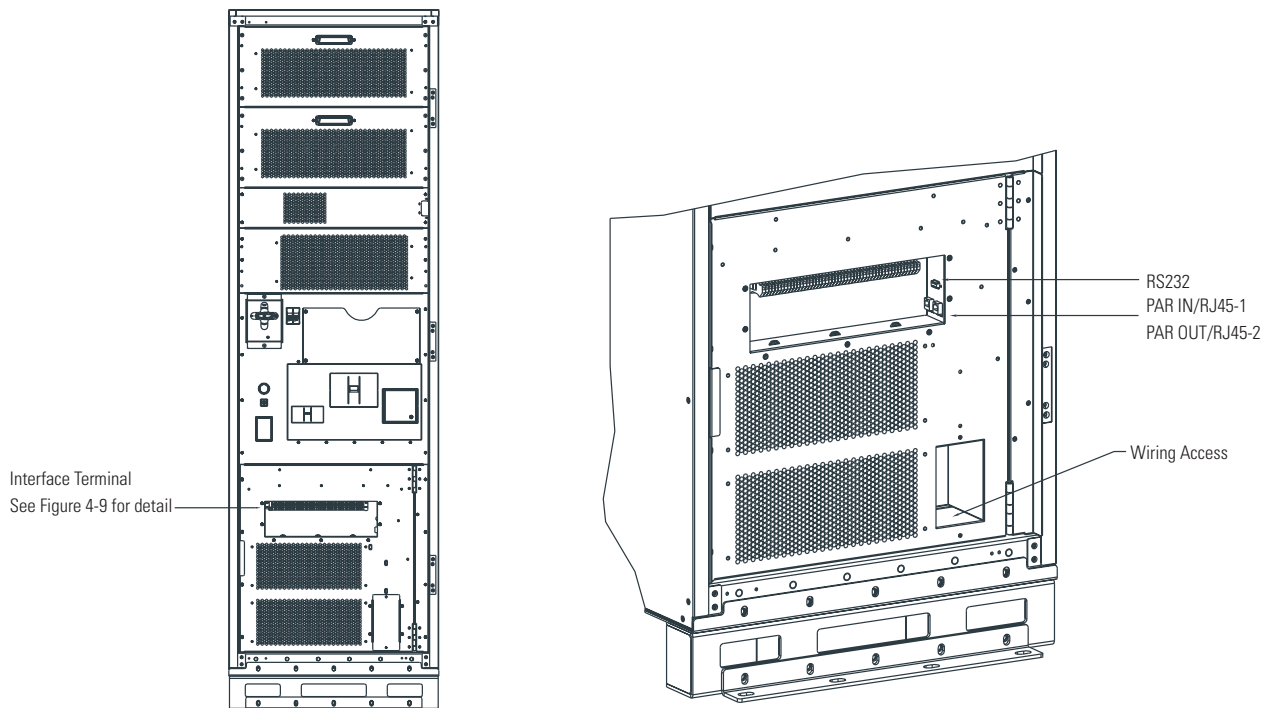

Figure 4-8. Interface Terminal Locations

1	2	3	4	5	6	7	8	9	10	11
RLY1-INPUT		RLY1-K1			RLY1-K2			RLY1-K3		
1	2	NC	COM	NO	NC	COM	NO	NC	COM	NO

12	13	14	15	16	17	18	19	20	21	22
RLY1-K4			RLY1-K5			RLY2-INPUT		RLY2-K1		
NC	COM	NO	NC	COM	NO	1	2	NC	COM	NO

23	24	25	26	27	28	29	30	31	32	33	34
RLY2-K2			RLY2-K3			RLY2-K4			RLY2-K5		
NC	COM	NO	NC	COM	NO	NC	COM	NO	NC	COM	NO

35	36	37	38	39	40	41	42	43	44	45	46
Building Alarm1		Building Alarm2		Building Alarm3		REPO				Pull Chain	
BA1 +	BA2 -	BA2 +	BA2 -	BA3 +	BA3 -	REPO_1	REPO_2	REPO_3	REPO_4	Pul CH+	Pul CH-

47	48	49	50
BAT TEMP			
TEMP+	TEMP-		

Figure 4-9. Interface Terminal Detail

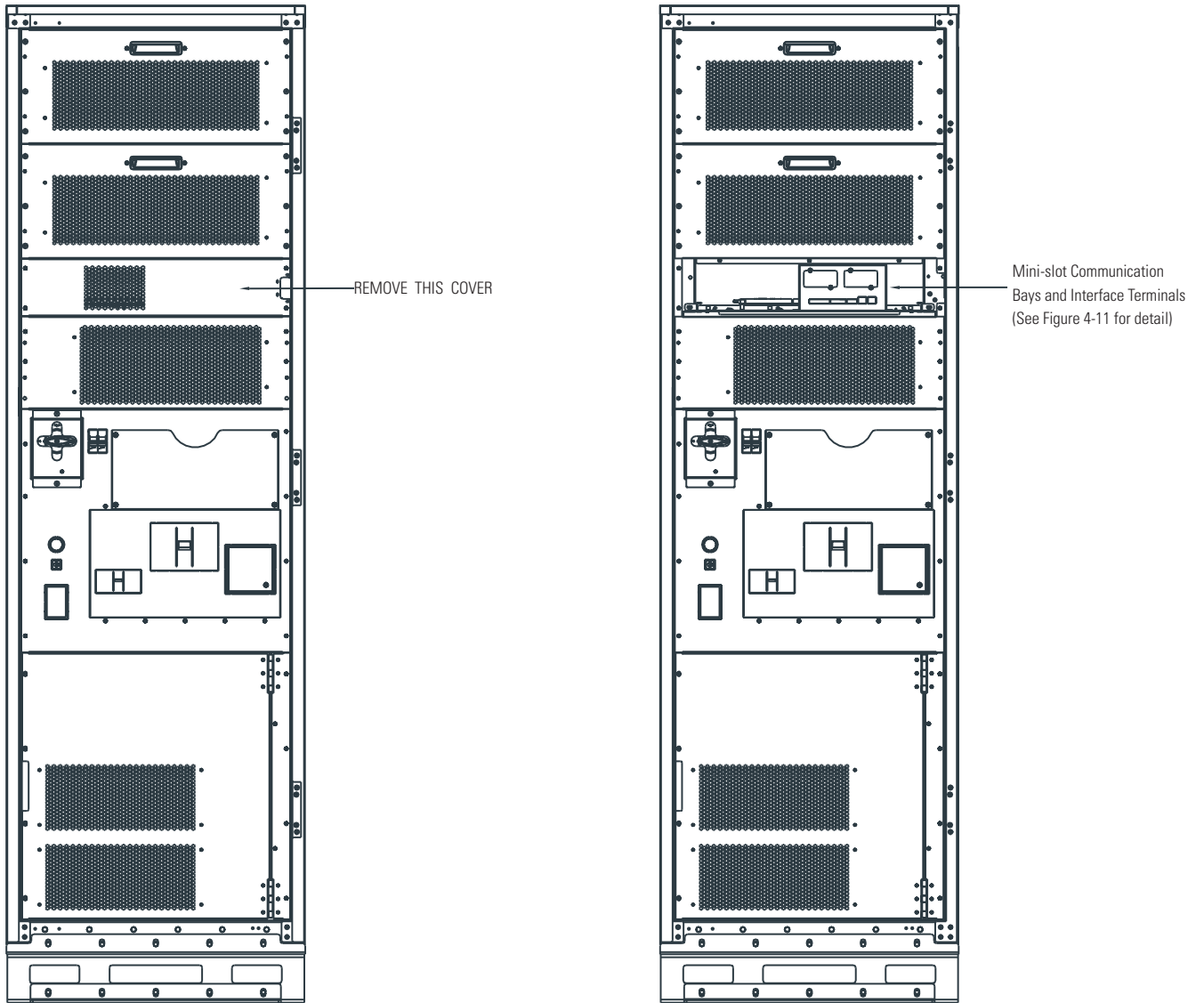

Figure 4-10. Interface Terminal Locations (without transfer)

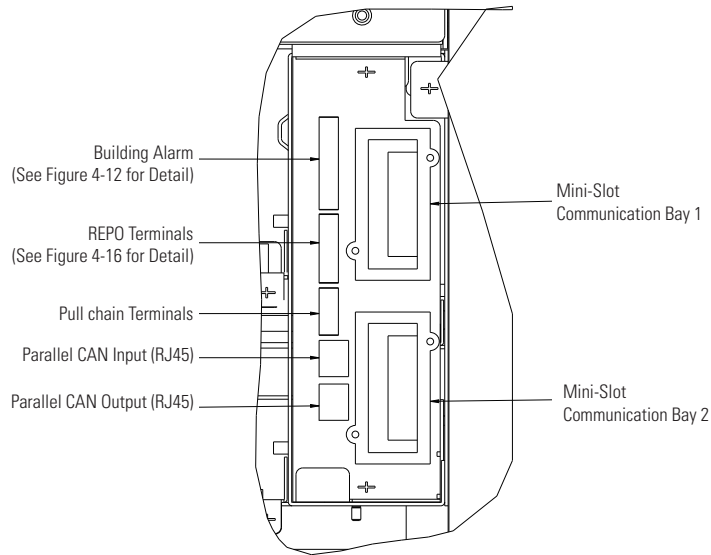

Figure 4-11. Interface Terminal Detail (without transfer)

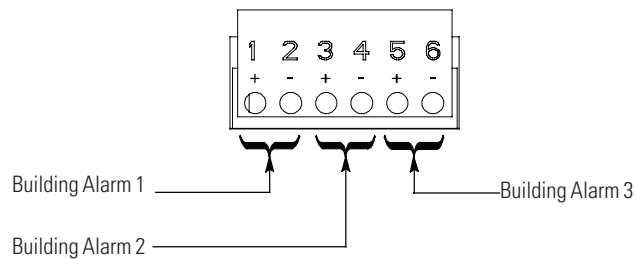

Figure 4-12. Building Alarm Terminal Block Connector Assignments (without transfer)

Table 4-1. Building Alarm Connections

Building Alarm Terminal	Name	Description
1	Building Alarm 1 +	Input: Programmable UPS alarm, activated by a remote dry contact closure.
2	Building Alarm 1 -	
3	Building Alarm 2 +	Input: Programmable UPS alarm, activated by a remote dry contact closure.
4	Building Alarm 2 -	
5	Building Alarm 3 +	Input: Programmable UPS alarm, activated by a remote dry contact closure.
6	Building Alarm 3 -	

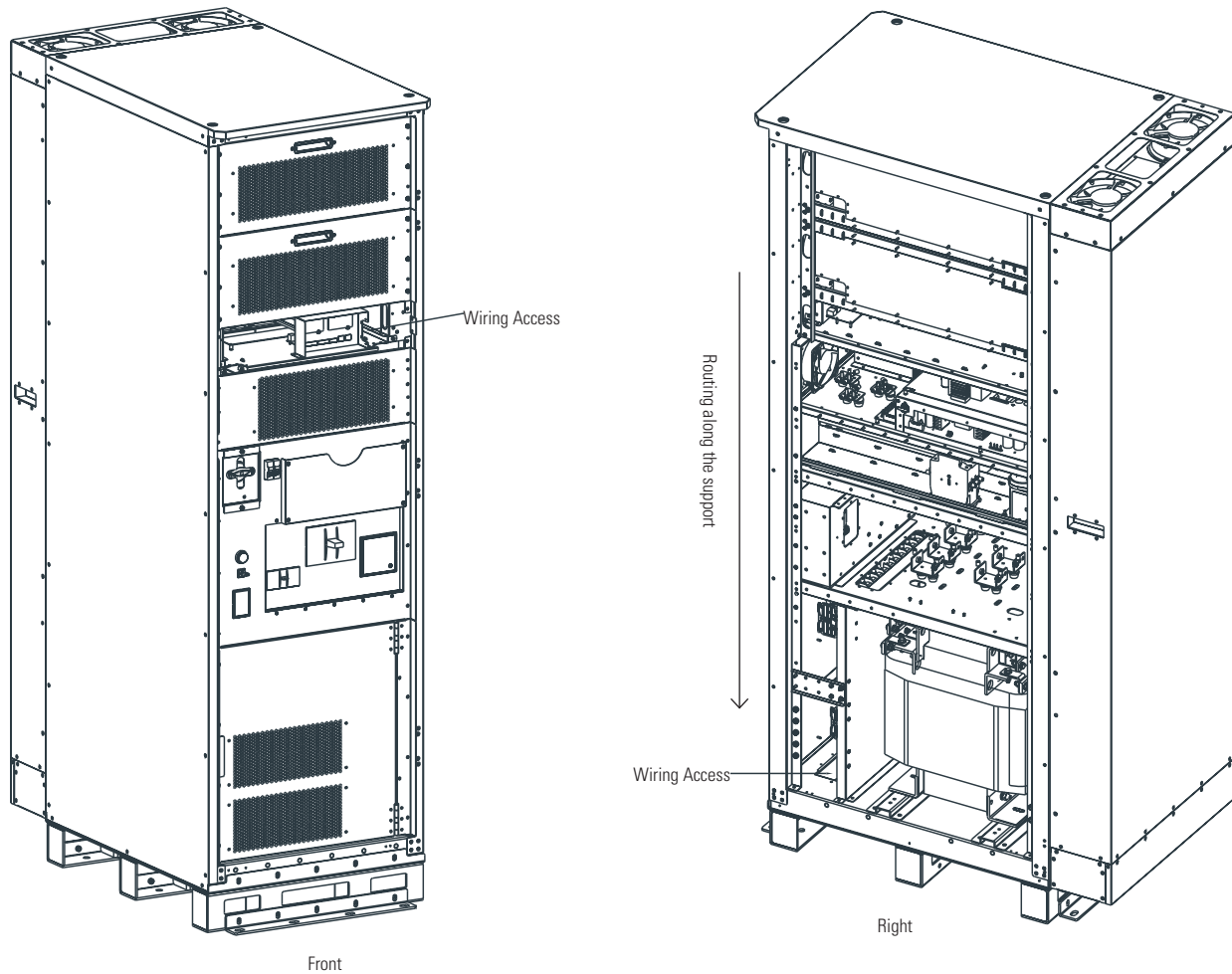

Figure 4-13. Interface Wiring Access (without transfer)

⚠ CAUTION

If the external communication terminal block is not present, It is necessary to ensure the equipment is not under operation and isolated the equipment completely from all input and output sources before working on the communication circuit.

Work on the communication circuit according to the below installation procedure:

1. Disconnect all input and output sources of power from this equipment.
 2. Check for hazardous voltage between all terminals including the protective earth, ensure the equipment has no hazardous voltage.
 3. Remove the front cover plate that covered the parallel communication ports and the right panel, then working on the communication circuit and routing as figure 4-13.
 4. After working the circuit, the front cover plate that covered the parallel communication ports and the right panel of the UPS must be installed and tightened.
-

4.5.2 Installing Parallel Pull Chain and CAN Control Wiring and Connections

To install wiring:

1. Verify the UPS system is turned off and all power sources are removed. See Chapter 6, "UPS Operating Instructions", for shutdown instructions.
2. Installing Parallel system, see Figure 4-15.

⚠ CAUTION

- Parallel system combined input and output cable length should be in accordance with the following rule. It should be designed to ensure that wiring impedance from point of supply to UPS input and from UPS output to load connection for each UPS module in a multi-module system is equal, or within a tolerance of approximately $\pm 10\%$. This is to ensure approximately equal current sharing when in static bypass mode and restrain input/output high frequency loop current of parallel system. Suggest that parallel system combined input and output cable length no less than 10m, no less than 5m no less than for input and no less than 5m no less than for output.

Total length of 1A = 2A = 3A = 4A

1B = 2B = 3B = 4B

1C = 2C = 3C = 4C

- If installing only two UPS modules (redundant), this requirement is no longer required as each UPS is capable of supporting the full bypass requirement. However, this would preclude future expansion.
 - Ensure that each UPS static bypass is fed from a single common source, as is an external bypass switch if installed. If each UPS is fed with a separate rectifier source, please consult Eaton for advice on compatibility.
-

3. To locate the appropriate terminals and review the wiring and termination requirements, see paragraph 3.2.3, Table 4-2, Figure 4-6 and Figure 4-11.

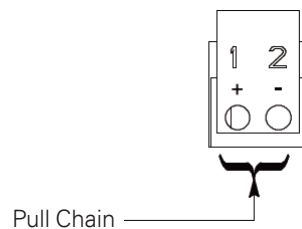
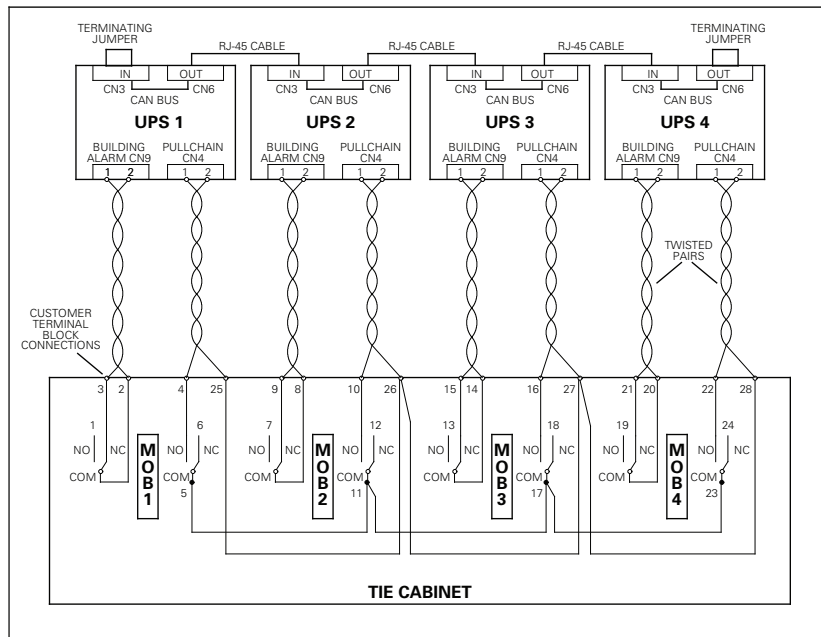

Figure 4-14. Pull Chain Terminal Block Connector Assignments

Table 4-2. Pull Chain Connections

Pull Chain Terminal	Name	Description
1	Pull Chain +	Output: Backup control for parallel operation.
2	Pull Chain -	

4. Remove the small parts from the knockout in the right side plate.
5. Route and install RJ-45 Controller Area Network (CAN) cables between the UPS cabinets. See Figure 4-6 and Figure 4-11 for wiring information.
6. Route and install pull chain wiring (Twisted Wires 0.5-2.0 mm²) between the UPS cabinets and cabinet MOBs. See Figure 4-6 and Figure 4-11 for wiring information.
7. If wiring Mini-Slot connections, proceed to paragraph 4.5.3;



Parallel UPS Control Wiring with MOBs

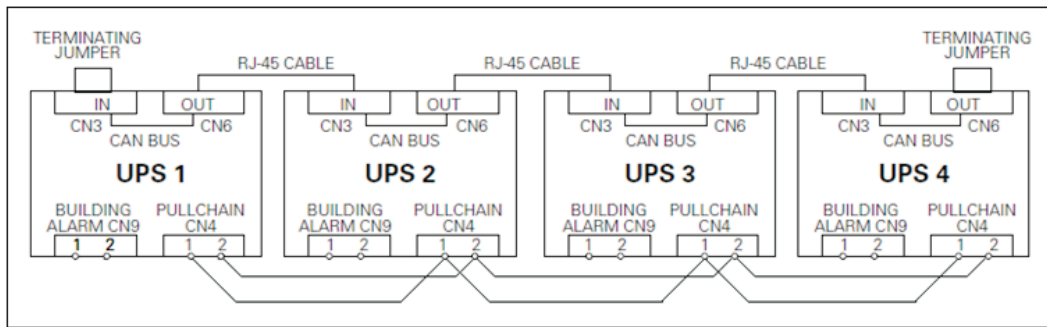

Parallel UPS Control Wiring without MOBs

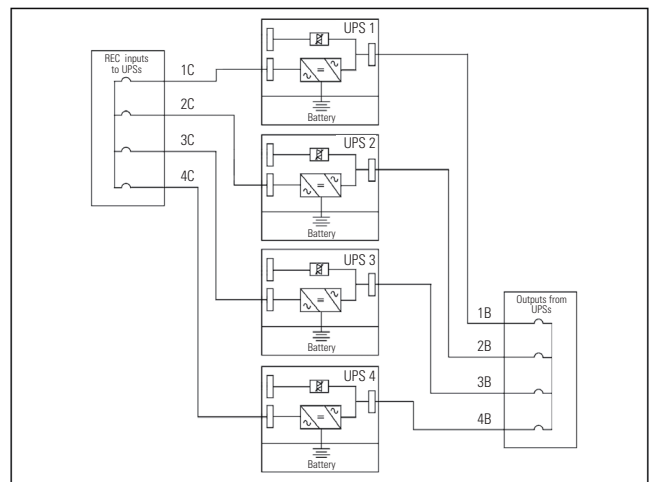
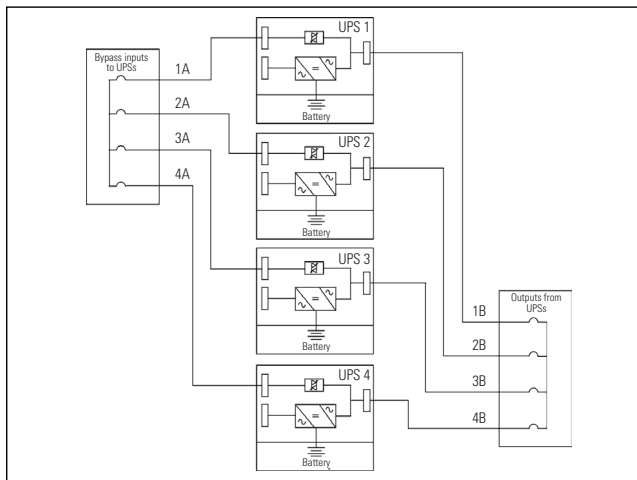

Parallel UPS system connections

Figure 4-15. Parallel UPS system connections

4.5.3 Installing Mini-Slot Interface Connections



NOTE LAN drop for connection to UPS communications card is to be supplied by customer.

For installation and setup of an Mini-Slot card, contact an Eaton service representative (see paragraph 1.8)

To install wiring:

1. If not already installed, install the LAN and telephone drops.
2. Route and install the LAN and other cables to the appropriate Mini-Slot cards. See Figure 4-6 and Figure 4-17 for Mini-Slot communication bay locations.
3. Refer to the manual supplied with the Mini-Slot card for operator instructions.
4. Install the power terminal cover using the provided hardware.

4.6 Installing a REPO Switch

A latching-type Remote Emergency Power-off (REPO) switch can be used in an emergency to shut down the UPS and remove power to the critical load from a location away from where the UPS is installed. Shows a REPO switch.



NOTE 1 Before installing a REPO switch, verify that the UPS was installed according to the instructions in paragraphs 4.2 through 4.5.

NOTE 2 When installing the REPO switch, you must install conduit between the device and the UPS cabinet for wiring the switch.

NOTE 3 The REPO switch must be a normally-open or normally-closed latching-type switch not tied into any other circuits.

NOTE 4 This procedure is intended for installing the Eaton-supplied REPO switch. If installing another manufacturer's switch, use this procedure, and Figure 4-13 and Figure 4-14 as a guide.

NOTE 5 The REPO switch wiring must be in accordance with local regulations.

To Install a REPO switch:

1. Verify the UPS system is turned off and all power sources are removed. See Chapter 6, "UPS Operating Instructions," for shutdown instructions.
2. Securely mount the REPO switch. Recommended locations include operator's consoles or near exit doors.
3. To locate the appropriate terminals and review the wiring and termination requirements, see paragraph 3.2.3, Table 4-3, Figure 4-6, Figure 4-8, and Figure 4-12.

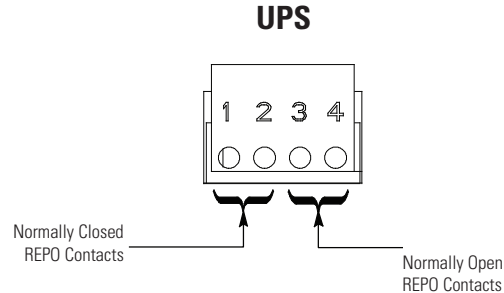

Figure 4-16. REPO Terminal Block Connector Assignments

Table 4-3. REPO Connections

REPO Terminal	Description
1	Input: normally-closed dry contact used to activate UPS EPO from a remote switch.
2	
3	Input: normally-open dry contact used to activate UPS EPO from a remote switch.
4	

4. Normally-Open REPO Switch Wiring see Table 4-4 and Figure 4-13, Normally-Closed REPO Switch Wiring see Table 4-5 and Figure 4-14 .
5. If using a normally-closed REPO switch, connect a jumper wire between pins 3 and 4 on the REPO terminal block.

6. If required, install wiring from the REPO switch to the trip circuitry of the upstream protective devices. A second contact block is provided on the REPO switch for this function. The REPO switch wiring must be in accordance with local regulations.
7. Reinstall the interface terminal cover using the retained hardware.

Table 4-4. REPO Connections

From REPO Station(s) Switch Contact Block (Either Block)	To REPO Terminal Block on Back of UPS Cabinet	Wire Size	Tightening Torque
3,4 NO	See Figure 4-13 for wiring	Twisted Wires (2) (0.5–2.0 mm ²)	7 lb in (0.8 Nm)

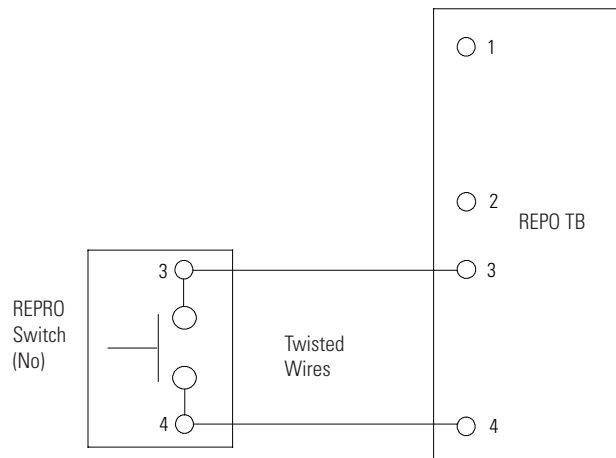

Figure 4-17. Normally-Open REPO Switch Wiring

Table 4-5. REPO Connections

From REPO Station(s) Switch Contact Block (Either Block)	To REPO Terminal Block on Back of UPS Cabinet	Wire Size	Tightening Torque
1,2,3,4 NC	See Figure 4-18 for wiring	Twisted Wires (2) (0.5 -2.0mm ²)	7 lb in (0.8 Nm)

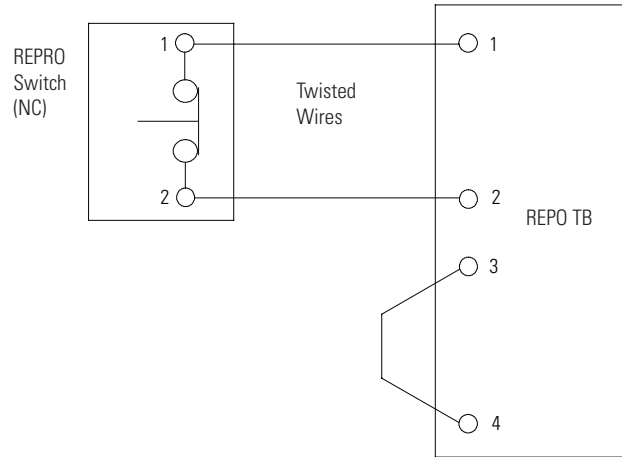

Figure 4-18. Normally-Closed REPO Switch Wiring

4.7 Initial Startup

Startup may be performed by the customer’s qualified electrical contractor for single (not parallel) UPS installations without any accessory cabinets.

Startup and operational checks for parallel systems or installations with accessory cabinets must be performed by an authorised Eaton Customer Service Engineer, or the warranty terms may become void. This service is offered as part of the sales contract for the UPS. Contact an Eaton service representative in advance (usually a two-week notice is required) to reserve a preferred startup date.

4.8 Completing the Installation Checklist

The final step in installing the UPS system is completing the following Installation Checklist. This checklist ensures that you have completely installed all hardware, cables, and other equipment. Complete all items listed on the checklist to ensure a smooth installation. Make a copy of the Installation Checklist before filling it out, and retain the original.

After the installation is complete, an Eaton Customer Service Engineer must verify the operation of the UPS system and commission it to support the critical load. The service representative cannot perform any installation tasks other than verifying software and operating setup parameters. Service personnel may request a copy of the completed Installation Checklist to verify all applicable equipment installations have been completed.



NOTE The Installation Checklist **MUST** be completed prior to starting the UPS system for the first time.

Installation Checklist

- All packing materials and restraints have been removed from each cabinet.
- The UPS cabinet is placed in its installed location.
- All conduits and cables are properly routed to the UPS and any ancillary cabinets.
- All power cables are properly sized and terminated.
- Neutral conductors are installed.
- A ground conductor is properly installed.
- Building alarms are wired appropriately. (Optional)
- LAN drops are installed. (Optional)
- LAN connections have been completed. (Optional)
- The REPO device is mounted in its installed location and its wiring is terminated inside the UPS cabinet. (Optional)
- A jumper wire is connected between pins 3 and 4 on the REPO terminal block if using a normally-closed REPO switch. (Optional)
- All terminal cover plates are installed.
- Accessories are mounted in installed locations and wiring is terminated inside the UPS cabinet. (Optional)
- Air conditioning equipment is installed and operating correctly.
- The area around the installed UPS system is clean and dust-free. (Eaton recommends that the UPS be installed on a level floor suitable for computer or electronic equipment.)
- Adequate workspace exists around the UPS and other cabinets.
- Adequate lighting is provided around all UPS equipment.
- A 230 Vac service outlet is located within 7.5 metres (25 feet) of the UPS equipment.
- Startup and operational checks are performed by an authorised Eaton Customer Service Engineer, for parallel systems or installations with accessory cabinets.

Parallel System Installation Checklist

- Each cabinet in the parallel system is placed in its installed location.
- All conduits and cables are properly routed to the UPSs and to the parallel tie cabinet.
- All power cables are properly sized and terminated.
- Neutral conductors are installed between cabinets as required.
- Ground conductors are properly installed.
- CAN wiring between the UPSs is properly installed.
- Pull chain wiring between the UPSs is properly installed.
- Adequate workspace exists around the UPSs, parallel tie cabinet, and other cabinets.
- Startup and operational checks are performed by an authorised Eaton Customer Service Engineer, for parallel systems.

Chapter 5 Understanding UPS Operation

5.1 UPS System Overview

The Eaton 9EHD UPS is a continuous-duty, solid-state, transformer-free, three-phase, true online system that provides conditioned and uninterruptible AC power to the UPS system's output and critical load.

The basic system consists of a rectifier, battery converter, inverter, monitoring/operation control panel, integrated communication server, and digital signal processor (DSP) logic. Figure 5-1 shows the main elements of the UPS system.

If utility power is interrupted or falls outside the parameters specified in Chapter 9, "Product Specifications," the UPS uses a backup battery supply to maintain power to the critical load for a specified period of time or until the utility power returns. For extended power outages, the UPS allows you to either transfer to an alternative power system (such as a generator) or shut down your critical load in an orderly manner.

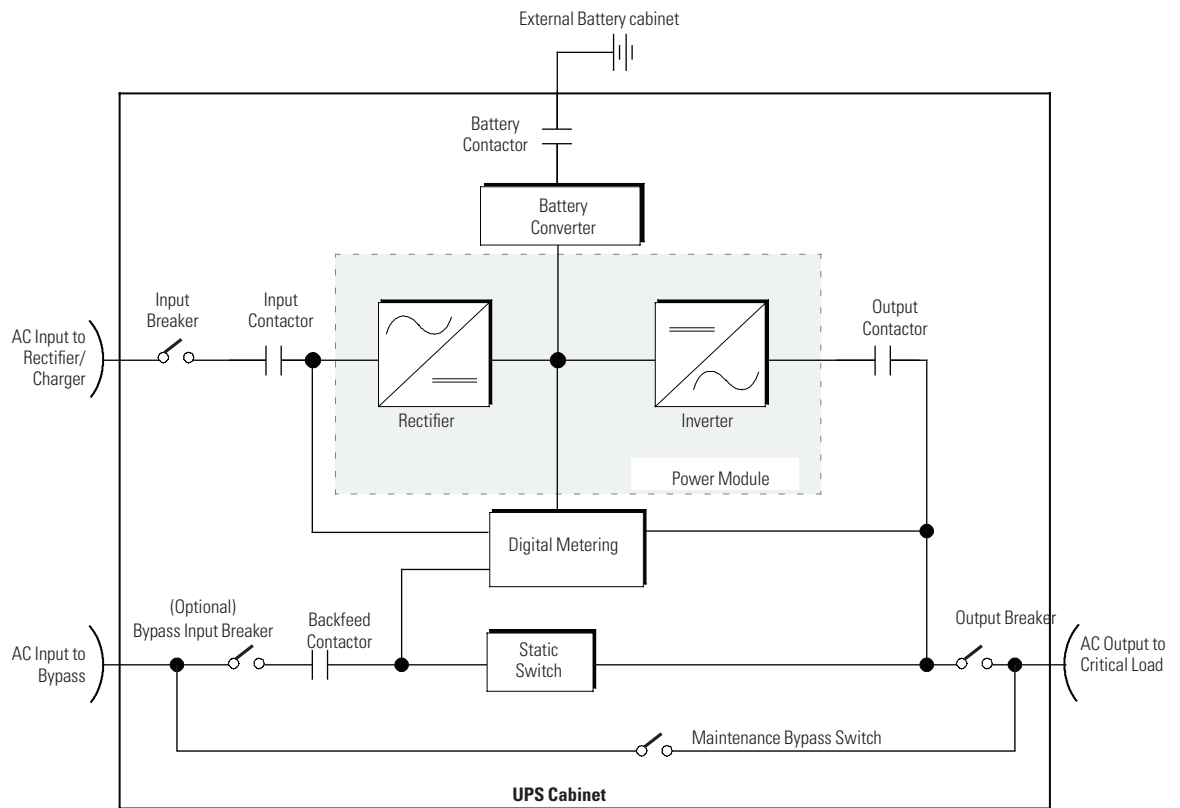

Figure 5-1. Main Elements of the UPS System

The emergency bypass consists of a continuous static switch, and an optional backfeed protection contactor. The backfeed protection contactor (if fitted) is located in series with the static switch. The static switch is armed and ready during normal operation.

5.2 Single UPS

A single UPS operates independently to support an applied load from the inverter, providing conditioned and uninterruptible AC power to the critical load from the output of the module. During an outage, the inverter continues to operate, supporting power to the load from the battery supply. If the unit requires service, applied loads are transferred to the internal bypass either automatically or manually. With the exception of an optional external battery cabinet, no other cabinets or equipment are required for the single UPS to successfully support its applied loads.

5.2.1 Modes

The Eaton 9EHD UPS supports a critical load in three different modes of operation:

- In Standard Normal mode, the critical load is supplied by the inverter, which derives its power from rectified utility AC power. In this mode, the battery charger also provides charging current for the battery, if needed, Standard mode is the standard normal operating mode.
- In Bypass mode, the critical load is directly supported by utility power.
- In Battery mode, the battery provides DC power, which maintains inverter operation. The battery supports the critical load.

The following paragraphs describe the differences in the UPS operating modes, using block diagrams to show the power flow during each mode of operation.

5.2.2 Standard Normal Mode

During Standard Normal mode, power for the system is derived from a utility input source through the rectifier input contactor. Three-phase AC input power is converted to DC using IGBT devices to produce a regulated DC voltage to the inverter. When the battery contactor is closed the battery is charged directly from the regulated rectifier output through a buck or boost DC converter, depending on the system voltage and the size of the battery string attached to the unit.

Figure 5-2 shows the path of electrical power through the UPS system when the UPS is operating in Normal mode.

The battery converter derives its input from the regulated DC output of the rectifier and provides either a boosted or bucked regulated DC voltage charge current to the battery. The battery is always connected to the UPS and ready to support the inverter should the utility input become unavailable.

The inverter produces a three-phase AC output to a customer's load without the use of a transformer. The inverter derives regulated DC from the rectifier and uses IGBT devices and pulse-width modulation (PWM) to produce a regulated and filtered AC output. The AC output of the inverter is delivered to the system output through the output contactor.

If the utility AC power is interrupted or is out of specification, the UPS automatically switches to Battery mode to support the critical load without interruption. When utility power returns, the UPS returns to Normal mode.

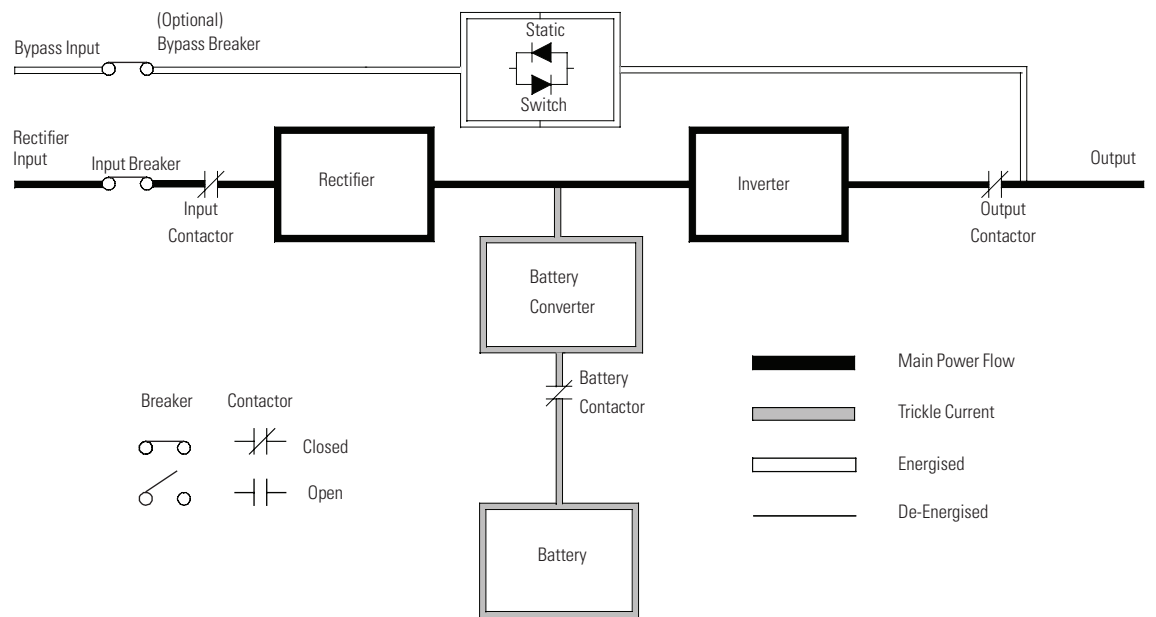

Figure 5-2. Path of Current Through the UPS in standard Normal Mode

If the UPS becomes overloaded or unavailable, the UPS switches to Bypass mode. The UPS automatically returns to Normal mode when the overload condition is cleared and system operation is restored within specified limits.

If the UPS suffers an internal failure, it switches automatically to Bypass mode and remains in that mode until the failure is corrected and the UPS is back in service.

5.2.3 Bypass Mode

CAUTION

The critical load is not protected from voltage or frequency fluctuations or power outages while the UPS is in Bypass mode.

The UPS automatically switches to Bypass mode if it detects an overload, load fault, or internal failure. The UPS can also be transferred from Normal mode to Bypass mode manually. The bypass source supplies the commercial AC power to the load directly. Figure 5-3 shows the path of electrical power through the UPS system when operating in Bypass mode.

In Bypass mode, the output of the system is provided with three-phase AC power directly from the system input. While in this mode, the output of the system is not protected from voltage or frequency fluctuations or power outages from the source. Some power line filtering and spike protection is provided to the load but no active power conditioning or battery support is available to the output of the system in the Bypass mode of operation.

The internal bypass is comprised of a solid-state, silicon-controlled rectifier (SCR) continuous static switch, and an optional backfeed protection contactor. The static switch is used instantaneously anytime the inverter is unable to support the applied load. The continuous static switch is wired in series with the backfeed protection contactor (if fitted), and together they are wired in parallel with the rectifier and inverter.

The static switch, being an electronically-controlled device, can be turned on immediately to pick up the load from the inverter while inverter output contactor opens to isolate the inverter. The backfeed protection contactor (if fitted) is normally closed, ready to support the static switch unless the bypass input source becomes unavailable.

If the UPS transfers to Bypass mode from Normal mode due to any reason other than operator intervention, the UPS automatically attempts to transfer back to Normal mode (up to three times within a ten minute period). The fourth transfer locks the critical load to the bypass source and requires operator intervention to transfer.

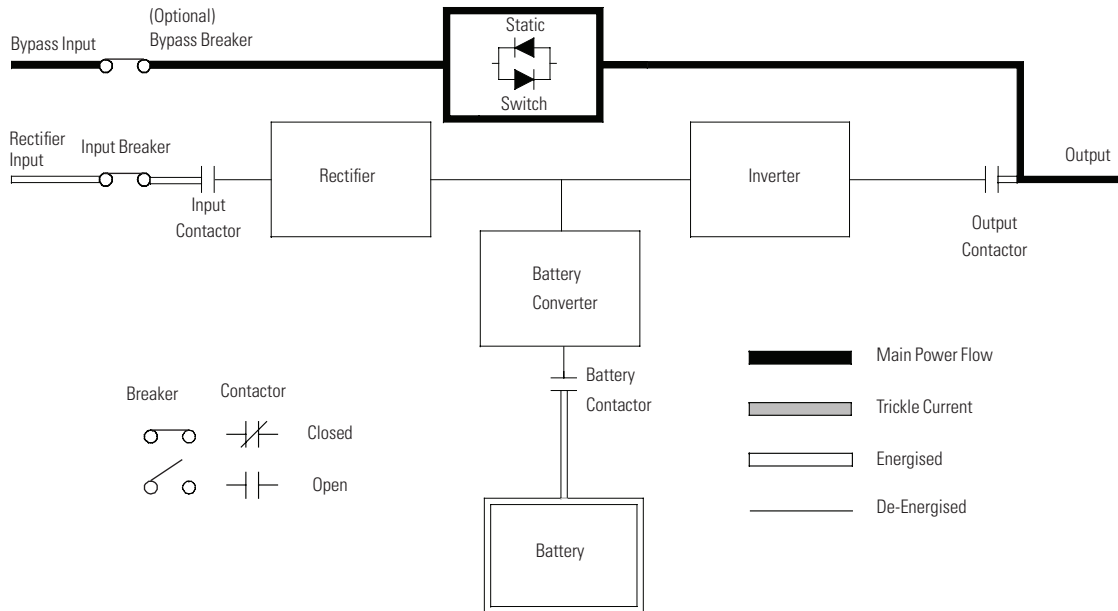

Figure 5-3. Path of Current Through the UPS in standard Bypass Mode

5.2.4 Battery Mode

The UPS automatically transfers to Battery mode if a utility power outage occurs, or if the utility power does not conform to specified parameters. In Battery mode, the battery provides emergency DC power that the inverter converts to AC power.

Figure 5-4 shows the path of electrical power through the UPS system when operating in Battery mode.

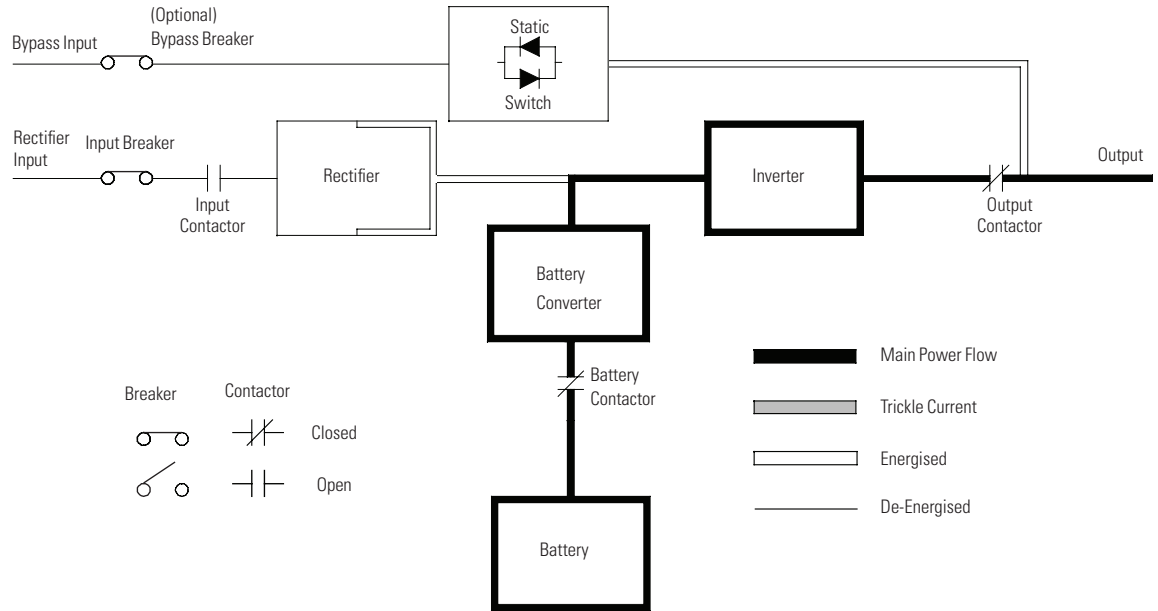

Figure 5-4. Path of Current Through the UPS in standard Battery Mode

During a utility power failure, the rectifier no longer has an AC utility source from which to supply the DC output voltage required to support the inverter. The input contactor opens and the battery instantaneously supplies energy to the battery converter. The converter boosts the voltage so that the inverter can support the customer's load without interruption. If bypass is common with the rectifier input, the backfeed protection contactor also opens. The opening of the input and the optional backfeed protection contactors prevent system voltages from bleeding backwards through the static switch and rectifier snubber components to the utility source.

If the input power fails to return or is not within the acceptance windows required for normal operation, the battery continues discharging until a DC voltage level is reached where the inverter output can no longer support the connected loads. When this event occurs, the UPS issues another set of audible and visual alarms indicating SHUTDOWN IMMINENT. Unless the rectifier has a valid AC input soon, the output can be supported for only two minutes before the output of the system shuts down. If the bypass source is available, the UPS transfers to bypass instead of shutting down.

If at any time during the battery discharge the input power becomes available again, the input and the backfeed protection contactors close and the rectifier begins to supply DC current to the converter and inverter. At this point, the unit returns to Normal mode. Depending on the total load and the duration of the battery discharge, battery current limit alarms may be seen for a short time due to the current required to recharge the battery.

5.3 Single UPS Unit System Online Configurations

The system oneline drawings in this section show the simplified internal structure of the UPS, battery supply, and basic maintenance bypass.

Online Drawing	UPS Model	Voltage		System Type
		Input	Output	
See Figure 5-5	See Table 9-1	380/400/415	380/400/415	Single Reverse Transfer UPS with External Battery

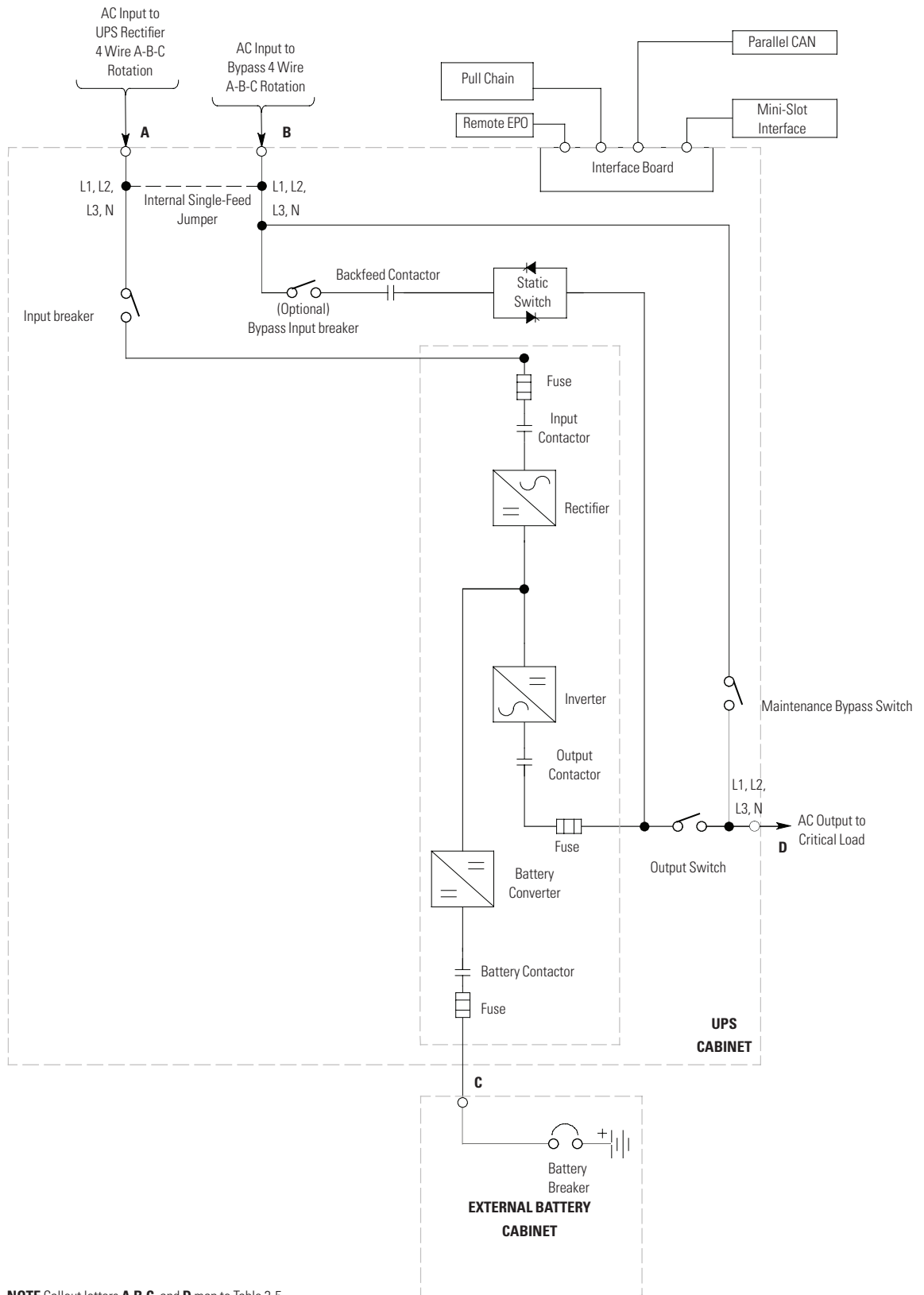

NOTE Callout letters **A,B,C,** and **D** map to Table 3-5.

Figure 5-5. UPS System Oneline(3 Phase Input, 3 Phase Output)

Chapter 6 UPS Operating Instructions

This section describes how to operate the UPS.



NOTE 1 Before starting the UPS, ensure all installation tasks are complete and a preliminary startup has been performed by authorized service personnel. The preliminary startup verifies all electrical interconnections to ensure the installation was successful and the system operates properly.

NOTE 2 Read this section of the manual and have thorough knowledge of UPS operation before attempting to operate any of the controls.

6.1 UPS Controls and Indicators

The controls and indicators identified and described in this section are used to control and monitor UPS operation. Figure 6-1 shows the controls and indicators and Figure 6-2 shows the UPS switches.

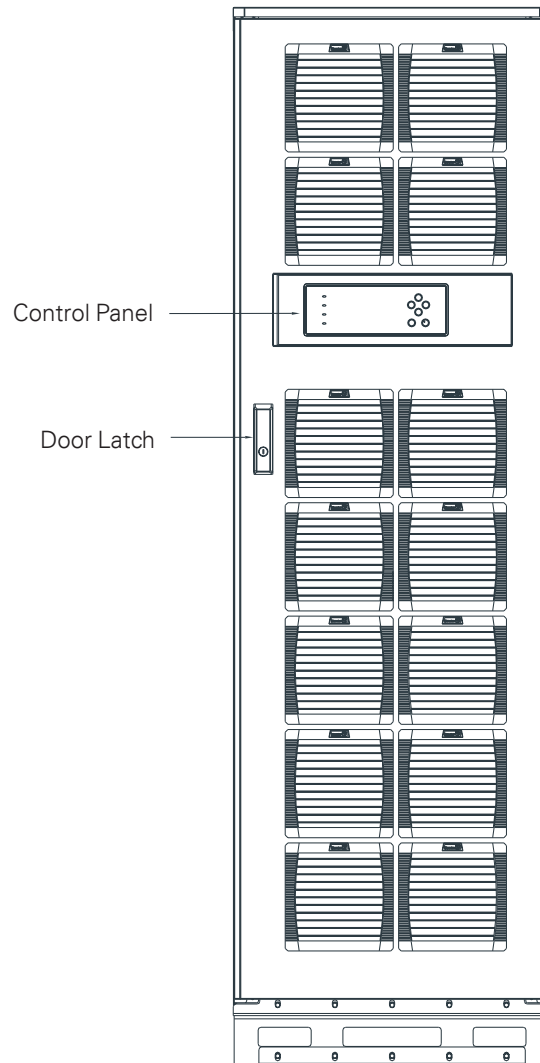

Figure 6-1. UPS Controls and Indicators

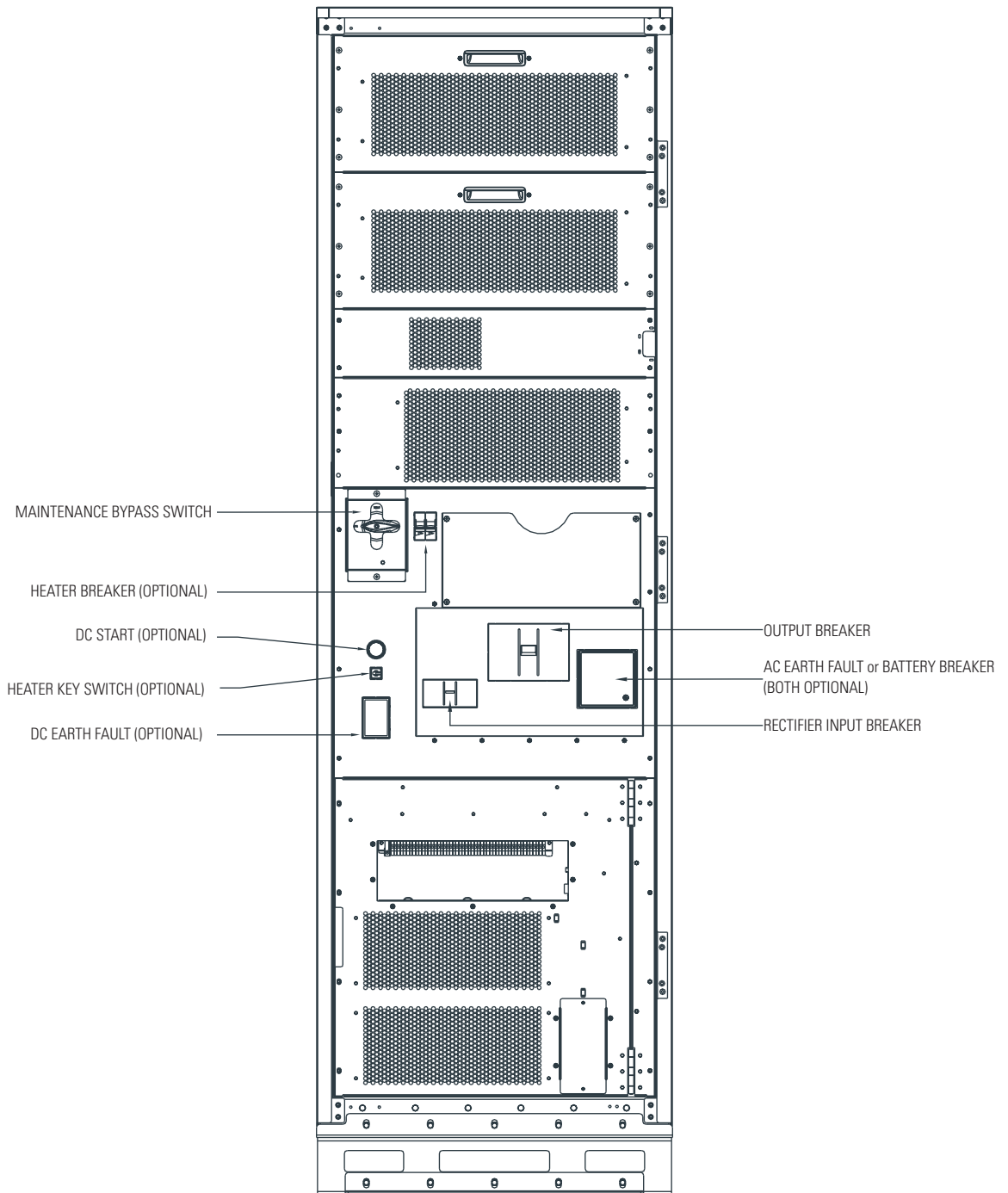

Figure 6-2. UPS Switches

6.1.1 Control Panel

The control panel is used to set up and control the UPS, and to monitor UPS operation. For a description of the UPS control panel functions, see paragraph 6.2.

6.2 Using the Control Panel

The following paragraphs describe the UPS control panel, including controls and indicators, and how to monitor UPS operation. The control panel (see Figure 6-3) is located on the front door of the UPS.

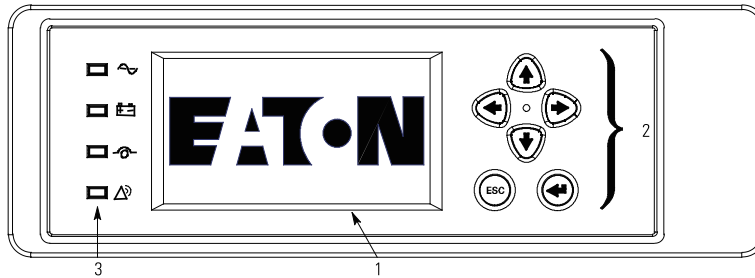

Figure 6-3. UPS Control Panel

The control panel consists of:

- A liquid crystal display (LCD) (1)
- Menu navigation pushbutton switches (2)
- A vertical column of status indicators (3). See paragraph 6.2.1.

The following paragraphs describe using the UPS control panel to monitor the UPS. See paragraph 6.3 for use of the operational controls.





When the unit powers up, the screen displays the Eaton logo as shown in Figure 6-3. To advance to the Main Menu and Mimic screen, press any control panel pushbutton once.

6.2.1 Status Indicators

The four symbols on the right side of the control panel are status indicators. These colored light emitting diode (LED) lamps work with the alarm horn to let you know the operating status of the UPS.

Table 6-1 describes the status indicators.

Table 6-1. Status Indicators

Indicator	Status	Description
 Green	On	The UPS is in Normal mode. The power module is supplying power to the critical load.
 Green	Off	The UPS is turned off.
 Yellow	On	The UPS is in Battery mode. Because Battery mode is a normal condition of the UPS, the Normal indicator also remains illuminated.
 Yellow	On	The UPS is in Bypass mode. The critical load is supported by the bypass source. The Normal indicator is not illuminated when the system is in Bypass mode.
 Red	On	The UPS has an active alarm and requires immediate attention. The LCD shows the highest priority active alarms. All alarms are accompanied by an audible horn. To silence the horn, press any control panel pushbutton once. The Alarm indicator may be illuminated along with other indicators.

6.2.2 System Events

When the UPS system is running in Normal mode, it continually monitors itself and the incoming utility power. In Battery or Bypass modes, the UPS may issue alarms to let you know exactly what event caused the change from Normal mode. System events on the UPS can be indicated by horns, lights, messages, or all three.

Select the EVENTS symbol from the menu bar on the main menu screen to display the active events screen. This screen shows any currently active alarms, notices, or commands. This screen shows any currently active alarms and notices. For more information on using the events screen, see paragraph 6.2.6.

- System Event Horns –The system event horn beeps to alert an operator that an event needing attention is taking place. The horn cycles at a half-second rate.
- System Event Indicators –The status indicators on the UPS control panel work with the event horn to let the operator know when the UPS is operating in any mode other than normal. Only the Normal mode indicator is illuminated during normal UPS system operation. The other indicators illuminate to indicate alarms or events. When an alarm occurs, first check these indicators to see what type of event has taken place. For descriptions of the status indicators, see paragraph 6.2.1.
- System Event Messages –When a system event occurs, a message appears on the LCD in the UPS status area. This message is also written to the Events Log and may be added to the History Log. The messages are divided into four categories: alarms, notices, status, and commands.

6.2.3 Using the LCD and Pushbuttons

The LCD on the control panel provides an operator interface with the UPS system. Figure 6-4 identifies the display areas discussed in the following sections.

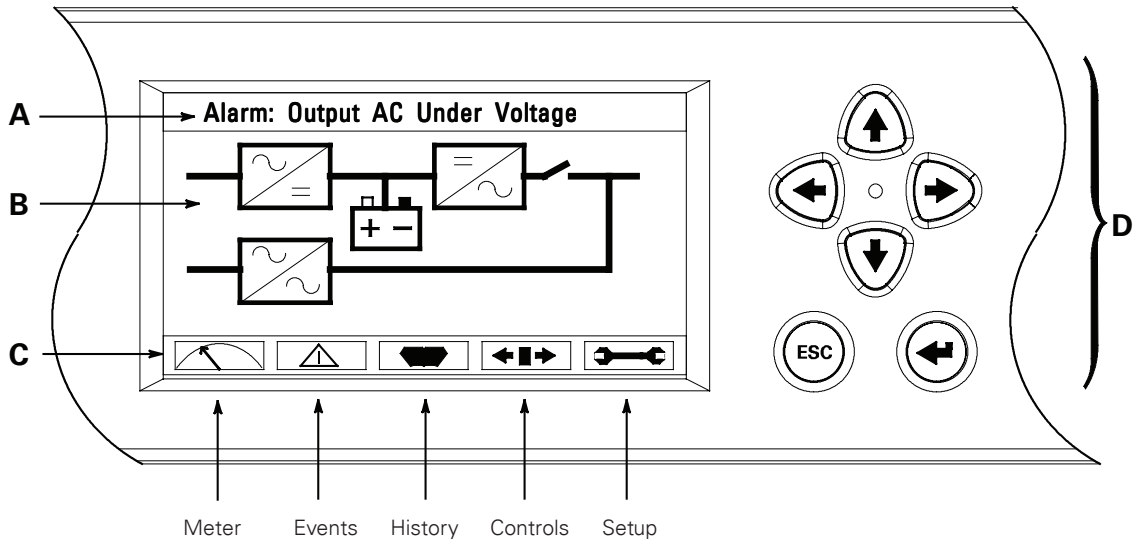

Figure 6-4. Parts of the LCD

- A** The UPS status area automatically scrolls between the Eaton model number, current date and time, active alarms, UPS status, load percent, and battery runtime for the UPS. The top line of display blinks while scrolling when the system needs attention. Some notices and alarms may be accompanied by an audible horn. To silence the horn, press any control panel pushbutton once. Shown is a typical alarm message. For more information about alarms and notices, see paragraph 6.2.2.
- B** The information area contains data about UPS status and operations.
- C** The menu bar shows the symbols of the available screens. To select a screen, highlight the screen symbol using the navigation pushbuttons and then press the RETURN pushbutton.
- D** The navigation pushbuttons function depending on the screen displayed. Use the Up, Down, Left, and Right pushbuttons to scroll through available screens and the Esc and Enter pushbuttons to select menu screens and functions.

You can use the LCD and the pushbuttons to:

- Look at a log of UPS events (alarms, notices, and commands) (see paragraph 6.2.6)
- Monitor UPS operation (see paragraph 6.2.6)
- Set UPS parameters (see paragraph 6.2.6)
- Control UPS operation (see paragraphs 6.2.6 and 6.2.7)

After approximately 10 minutes, the display screen darkens. To restore the screen, press any pushbutton once.

6.2.4 Using the Menu

The UPS menu bar allows you to display data in the information area to help you monitor and control UPS operation. Table 6-2 shows the basic menu structure.

Table 6-2. Display Function Menu Map

Menu Option	Description
METERS	Displays performance meters for the system or critical load.
EVENTS	Displays the list of Active System Events.
HISTORY	Displays a historical log of system events.
CONTROLS	Displays the System Control screen.
SETUP	Allows you to set the date and time for the time stamp, set the display language, the unit name, and meter subscripts, change the password, and view the firmware version numbers.
ESC	Returns to Main Menu and Mimic screen from the Meters, Events, History, Controls, or Setup screens. Returns to the main System Setup Level screen from a setup submenu.
←	Return arrow acknowledges or executes a command, or saves a setting.
↓ ↑	Up and down arrows scroll through screens and lists or highlight settings.
← →	Left and right arrows select or adjust settings displayed on the screen.

6.2.5 Mimic Screen

Figure 6-5 shows the Main Menu and Mimic screen. To select the Mimic screen from the Meters, Events, History, Controls, or Setup screens, press the ESC pushbutton on the current menu bar.

The Mimic screen shows the internal components of the UPS cabinet and a real-time graphical representation of the operating status of the system.

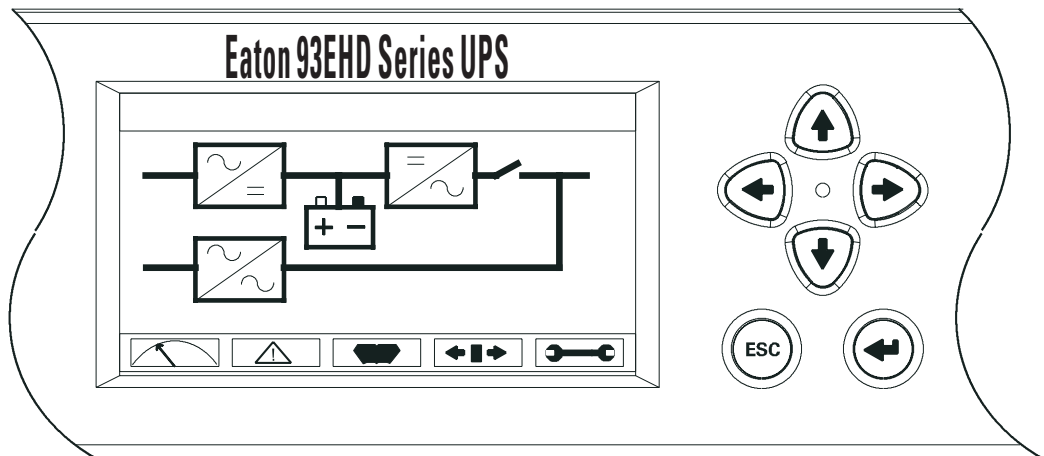

Figure 6-5. Main Menu and Mimic Screen

6.2.6 Display Menu Operation

Table 6-3 describes the menu functions and how to use them.

Table 6-3. Display Menu Operation

Function	Subfunction	Operation
Meters – UPS		The Meter screens show the UPS meter readings for the unit. The default voltage displayed on these screens is phase-to-neutral. These can be changed to display the voltage phase-to-phase (A-B, B-C, C-A). Use the LEFT or RIGHT arrow pushbuttons to select the METER symbol on the main menu bar, to display the Meter screens. To scroll through the meter screens, press the UP or DOWN arrow pushbutton. The current UPS readings are displayed in the information area of the screen.
	Output – UPS	The Output screen shows output voltage (phase to neutral), output current (each phase), and frequency being supplied by the UPS, as well as the kVA, kW, and power factor measurements.
	Input – UPS	The Input screen shows input voltage (phase to neutral), input current (each phase), and frequency of the incoming utility source, as well as the kVA, kW, and power factor measurements.
	Bypass	The Bypass screen shows the bypass input voltage (phase to neutral), input current (each phase), and frequency of the incoming utility source, as well as the kVA, kW, and power factor measurements.
	Battery – UPS	The Battery screen displays the battery voltage (Vdc) and the battery current (Idc).
Events		Use the LEFT or RIGHT arrow pushbuttons to select the EVENTS symbol on the main menu bar to display the Events screens. A listing of all system events that are currently active is displayed. The most recent event is listed first. As events clear, they are removed from the Events listing. To scroll through the events, press the UP or DOWN arrow pushbutton.
History		Use the LEFT or RIGHT arrow pushbuttons to select the HISTORY symbol on the main menu bar to display the History screen. The history Log lists up to 512 events in chronological order, with the most recent event listed last (once 512 is reached, the earliest event is overwritten). The end of the log (the most recent events) is displayed first; scroll upward to view older event listings. To scroll through the events, press the UP or DOWN arrow pushbutton.
Setup – User	Function Selection	This screen can be used to display user information and show the firmware versions installed. Use the LEFT or RIGHT arrow pushbuttons to select the SETUP symbol on the main menu bar to display the Setup screen. Use the UP or DOWN arrow pushbutton to highlight the function desired, then press the RETURN pushbutton to display the function screen. See Figure 6-6 for a typical screen display.
	User Info	The User Info screen provides the model, CTO and serial numbers of the UPS, the Output voltage, frequency, and kVA rating, the input voltage rating, and the battery run time rating. Use the LEFT or RIGHT arrow pushbuttons to select USER on the Setup menu bar. Use the UP or DOWN arrow pushbutton. to select Info, then press the RETURN pushbutton to display the function screen. To return to the System Setup screen, press the ESC pushbutton.
	About	The About screen provides the firmware version numbers installed on the UPS. Use the LEFT or RIGHT arrow pushbuttons to select USER on the Setup menu bar. Use the UP or DOWN arrow pushbutton. to select About. To return to the System Setup screen, press the ESC pushbutton.
Setup – Config (System Level 1 Setup)	Password	To enter a password if required, use the LEFT or RIGHT arrow pushbutton to select the password character position. Use the UP or DOWN arrow pushbutton to change the password character. Once the password is entered, select DONE and then press the RETURN pushbutton. The System Setup Level 1 menu screen is displayed. The default System Setup Level 1 password is 0101.
	Function Selection	This screen can be used to set the date and time, change the display language, enter a unit name, change the meter style, perform lamp test, clear the history log, and enter a password to access Level 1 functions. Use the LEFT or RIGHT arrow pushbuttons to select the SETUP symbol on the main menu bar to display the Setup screen. Use the LEFT or RIGHT arrow pushbutton to select CONFIG on the Setup menu bar. Enter a password if required.
	Clock	The Clock Setup screen allows the selection of either month/day/year or day/month/year formats and daylight savings time for display on the screen and for logging events in the Event and History Logs. Use the UP or DOWN arrow pushbutton to select CLOCK to display the Clock screen. Use the UP or DOWN arrow pushbutton to highlight the desired format, then press the RETURN pushbutton to display the Set Date and Time screen. To return to the System Setup screen, press the ESC pushbutton.

Table 6-3. Display Menu Operation

Function	Subfunction	Operation
Setup – Config (System Level 1 Setup) (continued)	Set Date and Time MM/DD/YYYY	The Set Date and Time MM/DD/YYYY screen allows the internal date and time of the UPS to be set in the month/day/year format. The date and time information is used for display on the screen and for logging events in the Event and History Logs. Use the LEFT or RIGHT arrow pushbutton to highlight the setting to be changed. Use the UP or DOWN arrow pushbutton to make the change. When finished making changes, use the LEFT or RIGHT arrow pushbutton to highlight SAVE and the UP or DOWN arrow pushbutton to select YES. To complete the save function and return to the System Setup screen, select the RETURN arrow pushbutton.
	Set Date and Time DD/MM/YYYY	The Set Date and Time DD/MM/YYYY screen allows the internal date and time of the UPS to be set in the day/month/year format. The date and time information is used for display on the screen and for logging events in the Event and History Logs. Use the LEFT or RIGHT arrow pushbutton to highlight the setting to be changed. Use the UP or DOWN arrow pushbutton to make the change. When finished making changes, use the LEFT or RIGHT arrow pushbutton to highlight SAVE and the UP or DOWN arrow pushbutton to select YES. To complete the save function and return to the System Setup screen, select the RETURN arrow pushbutton.
	Language	The Language Setup screen allows the display menu language to be selected. Use the UP or DOWN arrow pushbutton to highlight Language, then press the RETURN pushbutton to display the Language screen. Use the UP or DOWN arrow pushbutton to highlight the desired language, then press the RETURN pushbutton. To return to the System Setup screen, press the ESC pushbutton.
	Unit Name	The Unit Name Setup screen allows a unit name to be entered. Use the UP or DOWN arrow pushbutton to highlight Unit Name, then press the RETURN pushbutton to display the Unit Name screen. Use the LEFT or RIGHT arrow pushbutton to highlight the character to be changed. Use the UP or DOWN arrow pushbutton to make the change. When finished making changes, use the LEFT or RIGHT arrow pushbutton to highlight SAVE and the UP or DOWN arrow pushbutton to select YES. To complete the save function and return to the System Setup screen, select the RETURN arrow pushbutton. To return to the System Setup screen, press the ESC pushbutton.
	Meters	The Meters Setup screen allows the Meters Screen display style to be selected. Use the UP or DOWN arrow pushbutton to highlight Meters, then press the RETURN pushbutton to display the Meters screen. Use the UP or DOWN arrow pushbutton to highlight the desired style, then press the RETURN pushbutton. To return to the System Setup screen, press the ESC pushbutton.
	Lamp Test	The Lamp Test screen allows the control panel status lamps to be tested. Use the UP or DOWN arrow pushbutton to highlight Lamp Test, then press the RETURN pushbutton to illuminate the status lamps. To return to the System Setup screen, press the ESC pushbutton.
	Clear Log	The Clear Log screen allows the history log to be cleared. Use the UP or DOWN arrow pushbutton to highlight Clear Log, then press the RETURN pushbutton to clear the log. To return to the System Setup screen, press the ESC pushbutton.
	P/W	The P/W screen is used to change the System Setup Level 1 password. Use the UP or DOWN arrow pushbutton to highlight P/W, then press the RETURN pushbutton to display the P/W screen. Use the LEFT or RIGHT arrow pushbutton to select the password character position. Use the UP or DOWN arrow pushbutton to change the password character. Once the password is entered, select CHANGE and then press the RETURN pushbutton.
	Controls	See paragraph 6.2.7 for details.

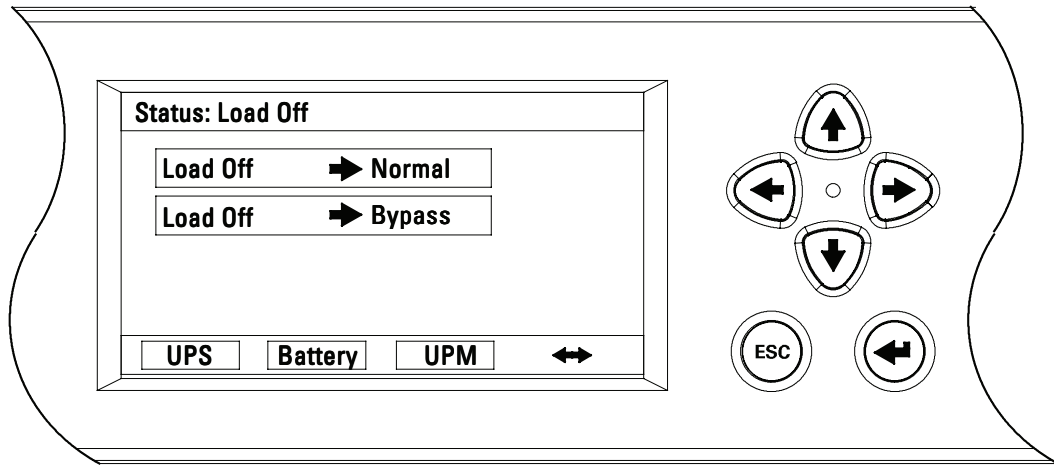

Figure 6-6. Typical Initial Setup Screen

6.2.7 System Controls

Select the CONTROLS symbol on the main menu bar, then press the RETURN pushbutton to display the Controls screen. Normal operation, transfer to bypass, load off, and charger control commands are controlled through this screen. In addition, the screen displays the current status of the UPS. Figure 6-7 shows the System Control screen.

Use the ← or → pushbutton to highlight the command screen desired, then press the RETURN pushbutton to display the command menu screen.

Use the ↑ or ↓ pushbutton to highlight the command desired.

Table 6-4 describes the control functions and provides instructions to access and use the command menu screens.

Table 6-5 lists the typical System Status Screen Messages that are displayed during UPS operation.

For detailed information about using the System Controls, see paragraph 6.3.

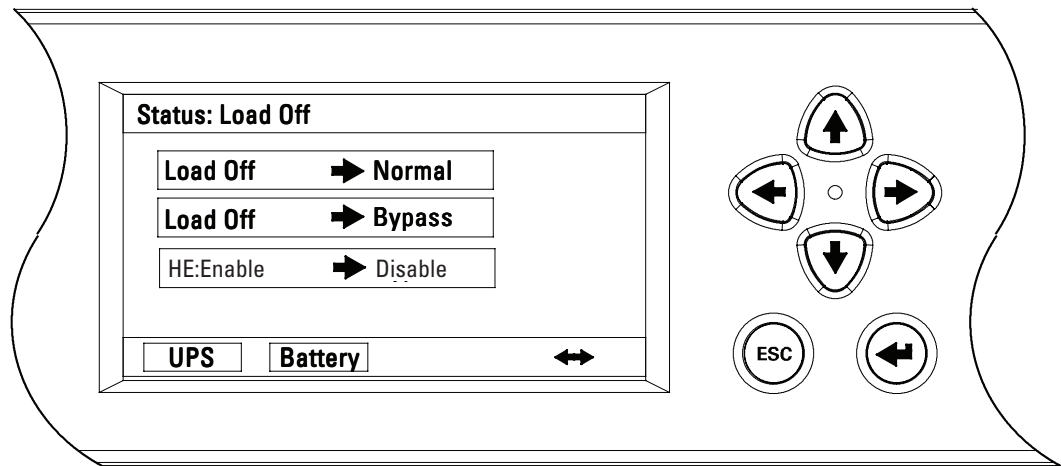

Figure 6-7. Typical System Control Screen

Table 6-4. Command Menu Operation

Function	Subfunction	Operation
UPS Control Commands		Use the up or down arrow pushbutton to highlight the command function desired, then press the RETURN pushbutton to execute the command or proceed to further command screens.
	Normal Mode	Starts the UPS in Standard Normal mode or transfers the UPS to Standard Normal mode from Bypass mode.
	Bypass Mode	Starts the UPS in Normal mode or transfers the UPS to Normal mode from Bypass mode.
	High-Efficiency (HE) Mode	Transfers the UPS from Standard Normal mode to HE mode. Transfers the from HE mode to Standard Normal mode.
Battery Control Commands		Use the up or down arrow pushbutton to highlight the command function desired, then press the RETURN pushbutton to execute the command.
	Charger	Turns the battery charger on.
	Resting	Turns the battery charger off.

Table 6-5. Typical System Status Messages

Function	Message
UPS	Load Off; Bypass; Online, HE
Bypass	Off; On; Available
Charger	Charger Resting; Charger

6.3 Single UPS Operation



NOTE

- Note switch operation nomenclature: Open = O = Off, Closed = I = On.
 - Refer to the **External Battery Cabinet Installation Manual** for EBC battery breaker location.
-

6.3.1 Starting the UPS in Standard Normal Mode (Default Mode)

To start the UPS system:

1. Unfasten the front door by lifting the latch from the bottom and turning to the right (counterclockwise) and swing the door open (see Figure 6-1).
2. Verify that the input and output breakers are open.
3. If the UPS contains bypass input breaker, verify the bypass input breaker is open .
4. If the UPS contains maintenance bypass switch, verify that the maintenance bypass switch is open or the 3-position maintenance bypass switch is on 'UPS' mode.
5. Close the UPS input feeder circuit breaker.
6. If the UPSs are wired for dual input, close the UPS Bypass input feeder circuit breaker.
7. Close the input breaker.
8. If the UPS contains bypass input breaker, close the bypass input breaker.
9. Close the output breaker.
10. Make sure MBS cover is installed.
11. Close the door and secure the latch.
12. Close the external battery breakers.
13. Observe the UPS control panel display becoming active, indicating logic power.
14. Verify no alarms are active.
15. Select the CONTROLS symbol on the main menu bar. The System Control screen is displayed.
16. If not already selected, select UPS on the System Control screen.
17. On the UPS System Control screen, select the LOAD OFF→NORMAL command, then press the RETURN pushbutton.
18. If requested, enter the Level 1 password. Default password is 1111.

After entering password, UPS will transfer to bypass first and the Bypass LED will illuminate.

The rectifier and inverter turn on. The inverter continues to ramp up to full voltage.

Once the inverter reaches full voltage, the UPS output contactor closes and the static switch turns off. Power is now supplied to the critical load in Standard Normal mode. It takes approximately one minute for the UPS to achieve Standard Normal mode.

The Normal status indicator is illuminated.

6.3.2 Starting the UPS in Bypass Mode

If the inverter output of the UPS is not available and the critical load needs to be energised:



In Bypass mode, the critical load is not protected from commercial power interruptions and abnormalities.

To start the UPS system:

1. Unfasten the front door by lifting the latch from the bottom and turning to the right (counterclockwise) and swing the door open (Figure 6-1).
2. Verify that the input and output breakers are open.
3. If the UPS contains bypass input breakers, verify that the bypass input breakers is open.
4. If the UPS contains maintenance bypass switch, verify that the maintenance bypass switch is open or the 3-position maintenance bypass switch is on 'UPS' mode.
5. Close the UPS input feeder circuit breaker.
6. If the UPS contains bypass input breaker, close the UPS Bypass input feeder circuit breaker.
7. Close the input breaker.
8. If the UPS contains two input sources, close the bypass input breaker.
9. Close the output breaker.
10. Make sure MBS cover is installed.
11. Close the door and secure the latch.
12. Close the external battery breakers.
13. Observe the UPS control panel display becoming active, indicating logic power.
14. Verify no alarms are active.
15. Select the CONTROLS symbol on the main menu bar. The System Control screen is displayed.
16. If not already selected, select UPS on the System Control screen.
17. On the UPS System Control screen, select the LOAD OFF → BYPASS command, then press the RETURN pushbutton.

6.3.3 Transfer from Normal to Bypass Mode

To transfer the critical load to Bypass mode:

 **CAUTION**

In Bypass mode, the critical load is not protected from commercial power interruptions and abnormalities.

1. Select the CONTROLS symbol on the main menu bar. The System Control screen is displayed.
2. If not already selected, select UPS on the System Control screen.
3. On the UPS System Control screen, select the NORMAL → BYPASS command, then press the RETURN pushbutton.

The UPS transfers to Bypass mode.

The BYPASS status indicator is illuminated. The power module remains on.

 **WARNING**

Power is present inside the UPS cabinet.

6.3.4 Transfer from Bypass to Normal Mode

To transfer the critical load to Normal mode:

1. Select the CONTROLS symbol on the main menu bar. The System Control screen is displayed.
2. If not already selected, select UPS on the System Control screen.
3. On the UPS System Control screen, select the BYPASS →NORMAL command, then press the RETURN pushbutton.

The UPS transfers to Normal mode. If the power module is not available, the system remains on bypass and an alarm sounds.

The NORMAL status indicator is illuminated.

6.3.5 Transfer from Normal Mode to Internal Maintenance Bypass

To transfer the load to maintenance bypass:

1. On the UPS System Control screen, select the NORMAL →BYPASS command, then press the RETURN
2. Loosen the screws that fix the cover over the maintenance bypass switch and slide the cover to the right. This action will signal the UPS to transfer to static bypass. Refer to Figure 6-8 for switch arrangement.
3. Verify that the LCD/LED display indicates the UPS is in Bypass mode.
4. Close the Maintenance Bypass switch.
5. Open the Bypass Input and Output switches separately .



NOTE

- The Neutral Switch should remain closed unless operated by a service technician.
 - Maintenance Bypass operate must be performed by an authorized Eaton Customer Service Engineer.
-



WARNING

Power is present inside the UPS cabinet.

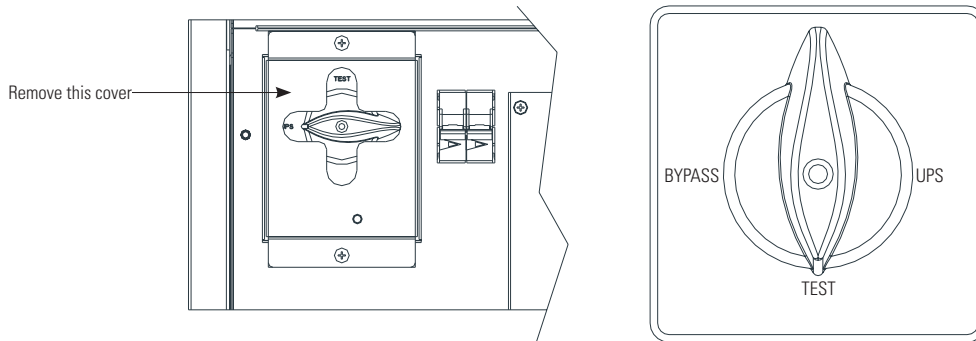

Figure 6-8. 20-40 kVA Optional internal Maintenance Bypass switch arrangement

6.3.6 Transfer from Internal Maintenance Bypass to Normal Mode

To transfer the load to Normal mode:

1. Output Breaker is all along closed.
2. Close the Input and Bypass input Breakers
3. Transform the 3-position Maintenance Bypass switch to 'Test' mode from 'BYPASS' mode.
4. Command the UPS to run in Bypass mode via the Control panel.
5. Verify that the LCD/LED display indicates the UPS is in Bypass mode.
6. Transform the 3-position Maintenance Bypass switch to 'UPS' mode from 'TEST' mode.
7. Fix the cover over the 3-position maintenance Bypass switch and tighten the screws.
8. Command the UPS to transfer to Normal mode via the control panel.

6.3.7 UPS and Critical Load Shutdown

To perform maintenance or service on the critical load, shut down power to the load:

1. Turn off all equipment that is being powered by the UPS.
2. Perform the LOAD OFF procedure in paragraph 6.3.12.
The output and bypass backfeed contactors (if fitted) open, and the power module is turned off.
3. Perform the battery charger off procedure in paragraph 6.3.10.
The input and battery contactors open.

 **WARNING**

Power is present inside the UPS cabinet after the upstream input feeder circuit breakers are opened because of the installed external battery cabinet.

4. Open the UPS Input breaker.
5. If the UPS contains a Bypass input breaker, open the Bypass input breaker.
6. If the UPS contains a Maintenance Bypass switch, open the Maintenance Bypass switch.
7. Open the UPS input and bypass feeder circuit breakers.
8. Open all external battery breakers.

6.3.8 Charger Control

To turn the battery charger on:

1. Select the CONTROLS symbol on the main menu bar. The System Control screen is displayed.
2. Select Battery on the System Control screen.
3. On the Battery System Control screen, select the RESTING → CHARGING command, then press the RETURN pushbutton.

To turn the battery charger off:

1. Select the CONTROLS symbol on the main menu bar. The System Control screen is displayed.
2. Select Battery on the System Control screen.
3. On the Battery System Control screen, select the CHARGING → RESTING command, then press the RETURN pushbutton.

6.3.9 Battery Test

NOTE 1 This UPS has a user initiated battery test intended to determine if the batteries are able to support the load.



NOTE 2 The battery test is only able to be initiated when the battery is fully charged. This normally occurs within 72 hours of the start of a charging cycle. The command will not be shown if the test is not able to be run.

To start the battery test:

1. Select the CONTROLS symbol on the main menu bar. The System Control screen is displayed.
2. Select Battery on the System Control screen.
3. On the Battery System Control screen, select the RESTING → TESTING command, then press the RETURN pushbutton.

6.3.10 Using the UPS LOAD OFF Command

A UPS Load Off is initiated by the Load Off command on the UPS Control screen. The UPS LOAD OFF controls the UPS output by powering down the UPS and de-energising the critical load.

The UPS (including Bypass) remains off until restarted.

To use the LOAD OFF command:

1. Select the CONTROLS symbol on the main menu bar. The System Control screen is displayed.
2. Select UPS on the System Control screen.
3. On the UPS System Control screen, select the NORMAL → LOAD OFF or BYPASS → LOAD OFF command depending on the UPS mode, then press the RETURN pushbutton.

The Verify Action screen is displayed, providing a choice to proceed or abort the shutdown.

CAUTION

All power to the critical load is lost when the LOAD OFF is selected in the following step. You should use this feature only when you want to de-energise the critical load.

4. Select Yes or no, then press the RETURN pushbutton.

Selecting Yes will immediately shut down the UPS and de-energising the critical load. Selecting No will abort the shutdown.

 **CAUTION**

Do not attempt to restart the system after Load Off until the cause of the shutdown has been identified and cleared.

5. To restart the UPS after pressing the LOAD OFF pushbutton, follow the procedure in paragraph 6.3.1 or 6.3.2.

 **WARNING**

Power is present inside the UPS cabinet after the upstream input feeder circuit breakers are opened because of the installed external battery cabinet.

6.3.11 Using the Remote Emergency Power-off Switch

A UPS emergency power-off is initiated by the REPO pushbutton switch. In an emergency, you can use this switch to control the UPS output. The REPO switch de-energises the critical load and powers down the UPS immediately, without asking for verification.

The UPS, including Bypass, remains off until restarted.

 **CAUTION**

All power to the critical load is lost when the REPO switch is activated in the following step. You should use this feature only when you want to de-energise the critical load.



NOTE

The following instructions are for the Eaton-supplied REPO switch. If a customer-supplied REPO switch is used, it may not activate in the same manner; refer to the operating instructions provided with the switch.

To use the REPO switch:

1. Firmly push the red pushbutton until it locks into place. The switch latches into the activated state .

The input, output, battery, and bypass backfeed contactors open, and the power module is turned off immediately, without asking for verification.

 **CAUTION**

Do not attempt to restart the system after the REPO until the cause of the shutdown has been identified and cleared.

2. To deactivate the REPO switch in preparation for restarting the UPS, insert the supplied key and rotate clockwise until the red pushbutton releases. To remove the key, rotate the key back to the vertical position.
3. Restart the UPS by following the procedure in paragraph 6.3.1 or 6.3.2.

6.4 Multiple UPS Parallel Operation

The paragraphs in this section provide operating instructions for a UPS system containing multiple UPSs.



NOTE 1 Refer to the **External Battery Cabinet Installation Manual** listed in paragraph 1.8 for EBC battery breaker location.

NOTE 2 Start and control system wide function from UPS 1.

6.4.1 Starting the Parallel UPS in Standard Normal Mode (Default Mode)

To start the UPS system:

1. Unfasten the front door by lifting the latch from the bottom and turning to the right (counterclockwise) and swing the door open (see Figure 6-1).
2. Verify that all input breakers are open.
3. If the UPSs contain a maintenance bypass breaker, verify that the maintenance bypass breakers are open.
4. Close all Module Output Breakers (MOBs).
5. Close all UPS input feeder circuit breakers.
6. If the UPSs are wired for dual input, close all of the UPSs Bypass input feeder circuit breakers.
7. Close all input breakers.
8. If the UPSs contain a bypass input switch, close all bypass input switches.
9. Close the door and secure the latch.
10. Close all external battery breakers.
11. Observe the UPS control panel display becoming active, indicating logic power.
12. Verify no alarms are active.
13. Select the CONTROLS symbol on the main menu bar. The System Control screen is displayed.
14. If not already selected, select UPS on the System Control screen.
15. On the UPS System Control screen, select the LOAD OFF → NORMAL command, then press the RETURN pushbutton.
16. If requested, enter the Level 1 password. Default password is 1111.

After entering password, UPS will transfer to bypass first and the Bypass LED will illuminate.

All rectifiers and inverters turn on. The inverters continue to ramp up to full voltage.

Once all inverters reach full voltage, the UPS output contactor closes and the static switch turns off. Power is now supplied to the critical load in Standard Normal mode. It takes approximately one minute for the UPS to achieve Standard Normal mode.

The Normal status indicator is illuminated.

17. If the UPS contains an output switch, close the output switch.

6.4.2 Starting the Parallel UPS in Bypass Mode

If the inverter output of the parallel UPS is not available and the critical load needs to be energised:

 **CAUTION**

In Bypass mode, the critical load is not protected from commercial power interruptions and abnormalities.

1. Unfasten the front door by lifting the latch from the bottom and turning to the right (counterclockwise) and swing the door open (Figure 6-1).
2. Verify that all input breaker are open.
3. If the UPSs contain a maintenance bypass switch, verify that the maintenance bypass switches are open.
4. Close all Module Output Breakers (MOBs).
5. Close all UPS input feeder circuit breakers.
6. If the UPSs are wired for dual input, close all of the UPS Bypass input feeder circuit breakers.
7. Close all input breakers.
8. If the UPSs contain a bypass input switch, close all of the bypass input switches.
9. Close the door and secure the latch.
10. Close the external battery breakers.
11. Observe the UPS control panel display becoming active, indicating logic power.
12. Verify no alarms are active.
13. Select the CONTROLS symbol on the main menu bar. The System Control screen is displayed.
14. If not already selected, select UPS on the System Control screen.
15. On the UPS System Control screen, select the LOAD OFF → BYPASS command, then press the RETURN pushbutton.

The critical load is immediately supplied by the bypass source, in Bypass mode from all UPSs.

The BYPASS status indicator is illuminated.

16. If the UPS contains an output switch, close the output switch.

6.4.3 Transfer from Normal to Bypass Mode

To transfer the critical load to Bypass mode:

 **CAUTION**

In Bypass mode, the critical load is not protected from commercial power interruptions and abnormalities.

1. Select the CONTROLS symbol on the main menu bar. The System Control screen is displayed.
2. If not already selected, select UPS on the System Control screen.
3. On the UPS System Control screen, select the NORMAL → BYPASS command, then press the RETURN pushbutton.

All of the UPSs transfer to Bypass mode.

The BYPASS status indicator is illuminated. The power module remains on.

 **WARNING**

Power is present inside the UPS cabinet.

6.4.4 Transfer from Bypass to Normal Mode

To transfer the critical load to Normal mode:

1. Select the CONTROLS symbol on the main menu bar. The System Control screen is displayed.
2. If not already selected, select UPS on the System Control screen.
3. On the UPS System Control screen, select the BYPASS → NORMAL command, then press the RETURN pushbutton.

All of the UPSs transfer to Normal mode. If the power module is not available, the system remains on bypass and an alarm sounds.

The NORMAL status indicator is illuminated.

 **WARNING**

Power is present inside the UPS cabinet.

6.4.5 Single UPS Shutdown

To shut down the UPS:

1. Open the MOB for the UPS being shut down.
2. Select the CONTROLS symbol on the main menu bar. The System Control screen is displayed.
3. If not already selected, select UPS on the System Control screen.
4. On the UPS System Control screen, select the NORMAL → UPS OFF command, then press the RETURN pushbutton.

The output and bypass backfeed contactors open, and the power module is turned off on the UPS being shut down.

Logic power remains on.

 **WARNING**

Power is present inside the UPS cabinet until the upstream input feeder circuit breaker is opened.

5. Open the UPS input and, if installed, the bypass feeder circuit breakers for the UPS being shut down.
6. If EBCs are installed, open all battery breakers

The UPS is now completely shut down.

6.4.6 Single UPS Restart

To restart a single UPS from a shutdown state:

1. Close the MOB for the UPS being restarted.
2. Close the UPS input and, if installed, bypass feeder circuit breakers for the UPS being restarted.
3. If the UPS contains an input switch, close the input switch.
4. If the UPS contains a bypass input switch, close the bypass input switch.
5. If the UPS contains an output switch, close the output switch.
6. Close the external battery breakers.
7. On the UPS being restarted, observe the UPS control panel display becoming active, indicating logic power.
8. Verify no alarms are active on the UPS being restarted.
9. On the UPS being restarted, select the CONTROLS symbol on the main menu bar. The System Control screen is displayed.
10. If not already selected, select UPS on the System Control screen.
11. On the UPS System Control screen, select the UPS OFF → NORMAL command, then press the RETURN pushbutton.
12. If requested, enter the Level 1 password. Default password is 1111.

The rectifier and inverter turn on. The inverter continues to ramp up to full voltage.

Once the inverter reaches full voltage, the UPS output contactor closes and the static switch turns off. Power is now supplied to the critical load in Standard Normal mode along with the other UPSs online. It takes approximately one minute for the UPS to achieve Standard Normal mode.

The Normal status indicator is illuminated.

6.4.7 UPS and Critical Load Shutdown

To perform maintenance or service on the critical load, shut down power to the load:

1. Turn off all equipment that is being powered by the UPS parallel system.
2. Transfer the UPSs to bypass by performing the procedure in paragraph 6.4.3.
3. Perform the LOAD OFF procedure in paragraph 6.4.10.

The output and bypass backfeed contactors open, and the power module is turned off.

4. Perform the battery charger off procedure in paragraph 6.4.8 for each UPS.

The input and battery contactors open.

WARNING

Power is present inside the UPS cabinets after the upstream input feeder circuit breakers are opened because of the installed external battery cabinet.

5. If the UPSs contain input switches, open all input switches.
6. If the UPSs contain bypass input switches, open all of the bypass input switches.
7. If the UPSs contain maintenance bypass switches, open all of the maintenance bypass switches.
8. If the UPSs contain an output switch, open the output switch.
9. Open all of the MOB.
10. Open all of the UPSs input and bypass feeder circuit breakers.
11. Open all external battery breakers

6.4.8 Charger Control

To turn an individual UPS battery charger on:

1. Select the CONTROLS symbol on the main menu bar on the UPS requiring the charger to be turned on. The System Control screen is displayed.
2. Select Battery on the System Control screen
3. On the Battery System Control screen, select the RESTING → CHARGING command, then press the RETURN pushbutton.

To turn an individual UPS battery charger off:

1. Select the CONTROLS symbol on the main menu bar on the UPS requiring the charger to be turned off. The System Control screen is displayed.
2. Select Battery on the System Control screen.
3. On the Battery System Control screen, select the CHARGING → RESTING command, then press the RETURN pushbutton.

6.4.9 Battery Test

NOTE 1 This UPS has a user initiated battery test intended to determine if the batteries are able to support the load.



NOTE 2 The battery test is only able to be initiated when the battery is fully charged. This normally occurs within 72 hours of the start of a charging cycle. The command will not be shown if the test is not able to be run.

To start an individual UPS battery test:

1. Select the CONTROLS symbol on the main menu bar on the UPS to be tested. The System Control screen is displayed.
2. Select Battery on the System Control screen.
3. On the Battery System Control screen, select the RESTING → TESTING command, then press the RETURN pushbutton.

6.4.10 Using the UPS LOAD OFF Command

A UPS Load Off is initiated by the Load Off command on the UPS Control screen. The UPS LOAD OFF controls the UPSs output by powering down the UPS and de-energising the critical load.

The UPSs (including Bypass) remains off until restarted.

To use the LOAD OFF command:

1. Select the CONTROLS symbol on the main menu bar on the UPS to be shut down. The System Control screen is displayed.
2. Select UPS on the System Control screen.
3. On the UPS System Control screen, select the NORMAL →LOAD OFF or BYPASS →LOAD OFF command depending on the UPS mode, then press the RETURN pushbutton.

The Verify Action screen is displayed, providing a choice to proceed or abort the shutdown.

 **CAUTION**

All power to the critical load is lost when the LOAD OFF is selected in the following step. You should use this feature only when you want to de-energise the critical load.

4. Select Yes or no, then press the RETURN pushbutton.
Selecting Yes will immediately shut down the UPS and de-energising the critical load. Selecting No will abort the shutdown.
5. If another UPS is to be shut down, proceed to that UPS and repeat Step 1 through Step 4.

 **CAUTION**

Do not attempt to restart the system after Load Off until the cause of the shutdown has been identified and cleared.

6. To restart the UPS after pressing the LOAD OFF pushbutton, follow the procedure in paragraph 6.4.1 or 6.4.2.

 **WARNING**

Power is present inside the UPS cabinet after the upstream input feeder circuit breakers are opened because of the installed external battery cabinet.

6.4.11 Using the Remote Emergency Power-off Switch

A UPS emergency power-off is initiated by the REPO pushbutton switch. In an emergency, you can use this switch to control the UPS output. The REPO switch de-energises the critical load and powers down the UPS immediately, without asking for verification.

The UPSs, including Bypass, remains off until restarted.

 **CAUTION**

All power to the critical load is lost when the REPO switch is activated in the following step. You should use this feature only when you want to de-energise the critical load.



NOTE

The following instructions are for the Eaton-supplied REPO switch. If a customer-supplied REPO switch is used, it may not activate in the same manner; refer to the operating instructions provided with the switch.

To use the REPO switch:

1. Firmly push the red pushbutton until it locks into place. The switch latches into the activated state .
The input, output, battery, and optional bypass backfeed contactors open, and the power module is turned off immediately, without asking for verification.

 **CAUTION**

Do not attempt to restart the system after the REPO until the cause of the shutdown has been identified and cleared.

2. To deactivate the REPO switch in preparation for restarting the UPS, insert the supplied key and rotate clockwise until the red pushbutton releases. To remove the key, rotate the key back to the vertical position.
3. Restart the UPS by following the procedure in paragraph 6.4.1 or 6.4.2.

 **WARNING**

Power is present inside the UPS cabinet after the upstream input feeder circuit breakers are opened because of the installed external battery cabinet.

Chapter 7 Communication

This chapter describes the communication features of the Eaton 9EHD UPS. For terminal wiring information, see paragraph 3.2.3 and paragraph 4.4. For location of the customer interface panel and terminals, see Figure 4-9 and Figure 4-10.

7.1 Mini-Slot Cards

The Eaton 9EHD UPS has two standard, factory-installed Mini-Slot communication bays. See Figure 4-9 for bay locations. The UPS is compatible with the following Mini-Slot cards (see Figure 7-1):

- Network Management Card and Modbus/Jbus – provides remote monitoring through a Web browser interface, e-mail, and a network management system (NMS) using SNMP and connects to a twisted-pair Ethernet (10/100BaseT) network. The card also provides direct integration of UPS information (meters and status) to a Building Management System (BMS) using the Modbus RTU protocol.
- Network Management Card – provides remote monitoring through a Web browser interface, e-mail, and a network management system (NMS) using SNMP and connects to a twisted-pair Ethernet (10/100BaseT) network.
- Management Card Contact and RS232 / Serial – two types of interfaces via a DB9 connector are available with this card. Dry contact mode provides a simple way to transmit UPS information to an alarm system, PLC, or computer system via dry relay contacts. The transmitted information is load powered, load on bypass, load on battery, load on utility, battery fault, and low battery. RS232 mode provides an RS232 interface for connection to a PC or to a UPS Control display unit. Jumpers are used to select the interface (contacts or RS232).

LAN and telephone drops for use with Mini-Slot connectivity cards must be supplied by facility planners or the customer.

The Industrial relay Card-MS (IRC-MS) provides a simple way to remotely input UPS information to an alarm system, PLC or a computer system via dry contacts. It offers five isolated dry contact outputs and one isolated dry contact input.

Relays K1 through K5 are identical in function. Each output contact function can be assigned by the customer. The UPS information is also configurable.

For installation and setup of a Mini-Slot card, contact an Eaton service representative (see paragraph 1.8). Refer to the manual supplied with the Mini-Slot card for user instructions.

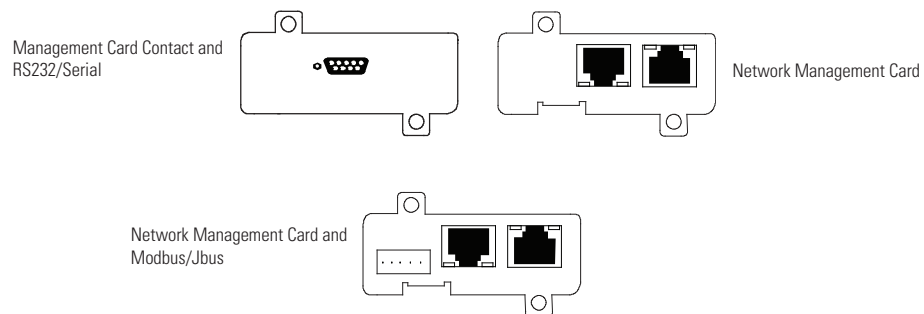

Figure 7-1. Optional Mini-Slot Cards

7.2 Relay Card-MS

Two types of interfaces via a DB9 connector are available with this card. Dry contact mode provides a simple way to transmit UPS information to an alarm system, PLC, or computer system via dry relay contacts. By default the transmitted information is load powered, load on bypass, load on battery, load on utility, battery fault, and low battery. RS232 mode provides an RS232 interface for connection to a PC or to a UPS Control display unit. Jumpers are used to select the interface (contacts or RS232).

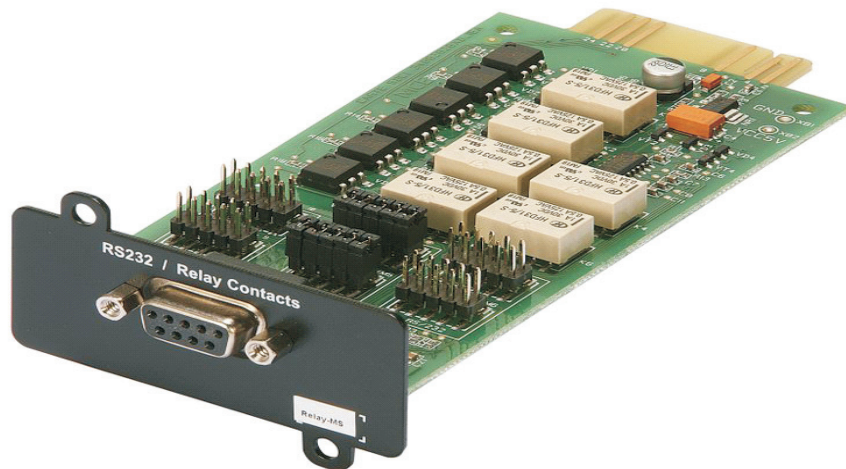

Figure 7-2. Relay Card-MS

7.3 Building Alarm Monitoring

This standard feature lets you connect the UPS to your building alarms, such as smoke detectors or overtemperature alarms. The customer interface terminals for external connections are located inside the UPS. Use twisted-pair wires for each alarm input and common, refer Figure 4-9. The building alarms can be programmed to display the alarm functional name.

Chapter 8 UPS Maintenance

The components inside the UPS cabinet are secured to a sturdy metal frame. All repairable parts and assemblies are located for easy removal, with very little disassembly. This design allows authorised service personnel to perform routine maintenance and servicing quickly.

You must schedule periodic performance checks of your UPS system to keep it running properly. Regular routine checks of operation and system parameters enable your system to function efficiently for many trouble-free years.

8.1 Important Safety Instructions

Remember that your UPS system is designed to supply power **EVEN WHEN DISCONNECTED FROM THE UTILITY POWER**. The UPS module interiors are unsafe until the DC power source is disconnected and the electrolytic capacitors are discharged. After disconnecting the utility power and the DC power, authorised service personnel should wait at least five minutes for capacitor bleedoff before attempting internal access to the UPS module.

 **WARNING**

- Servicing and maintenance should be performed by qualified service personnel only.
- **LETHAL VOLTAGE PRESENT.** This unit should not be operated with the cabinet doors open or protective panels removed. Do not make any assumptions about the electrical state of any cabinet in the UPS system.

Each battery string is an energy source in itself. **DO NOT ATTEMPT TO ACCESS ANY INTERNAL AREA OF THE BATTERY STRING YOURSELF. VOLTAGES ARE ALWAYS PRESENT IN THE BATTERY STRING.** If you suspect that a battery string needs service, contact an Eaton service representative.

If the string requires service contact an Eaton service representative.

 **WARNING**

The UPS don't work in normal model when performing battery maintenance.

Observe these precautions when working on or around batteries:

- Remove watches, rings, or other metal objects.
- Use tools with insulated handles.
- Wear rubber gloves and boots.
- Do not lay tools or metal parts on top of batteries.
- Disconnect the charging source prior to connecting or disconnecting terminals.
- Determine if the battery is inadvertently grounded. If it is, remove the source of the ground. Contact with any part of a grounded battery can result in electrical shock. The likelihood of such shock is reduced if such grounds are removed during installation and maintenance.
- When replacing lead-acid batteries, use the same number of sealed, lead-acid batteries.
- When replacing nickel-cadmium batteries, use the same number of nickel-cadmium batteries.
- Proper disposal of batteries is required. Refer to your local codes for disposal requirements.
- Do not dispose of batteries in a fire. Batteries may explode when exposed to flame.
- Do not open or mutilate batteries. Released electrolyte is harmful to the skin and eyes. It may be toxic.

8.2 Performing Preventative Maintenance

The UPS system requires very little preventative maintenance. However, the system should be inspected periodically to verify that the units are operating normally and that the batteries are in good condition.

8.2.1 DAILY Maintenance

Perform the following steps daily:

1. Check the area surrounding the UPS system. Ensure the area is not cluttered, allowing free access to the unit.
2. Ensure the air intakes (vents on the front door of the UPS cabinet and the exhaust openings (on the rear of the UPS cabinet) are not blocked.
3. Ensure the operating environment is within the parameters specified in paragraph 3.2.1 and Chapter 9, "Product Specifications."
4. Ensure the UPS is in Normal mode (Normal status indicator is illuminated). If an alarm lamp is illuminated or the Normal status indicator is not illuminated, contact an Eaton service representative.

8.2.2 MONTHLY Maintenance

Perform the following steps monthly:

1. Monitor system parameters as described in paragraph 6.2, "Using the Control Panel."
2. Check the UPS air filters (located behind the front door) and wash or replace as necessary. See Figure 8-1 for filter location. Contact an Eaton service representative for replacement filters. To remove the filters:

 **CAUTION**

Verify washed filter is thoroughly dry before reinstalling.

- a. Unfasten the front door by lifting the latch from the bottom and turning to the right (counterclockwise) and swing the door open (see Figure 6-1).
 - b. Remove the upper and lower foam filters from the frame on the front door.
 - c. Replace the washed or new foam filters into the frame on the front door.
 - d. Close the front door and secure the latch.
3. Record maintenance results and any corrective actions in a suitable log.

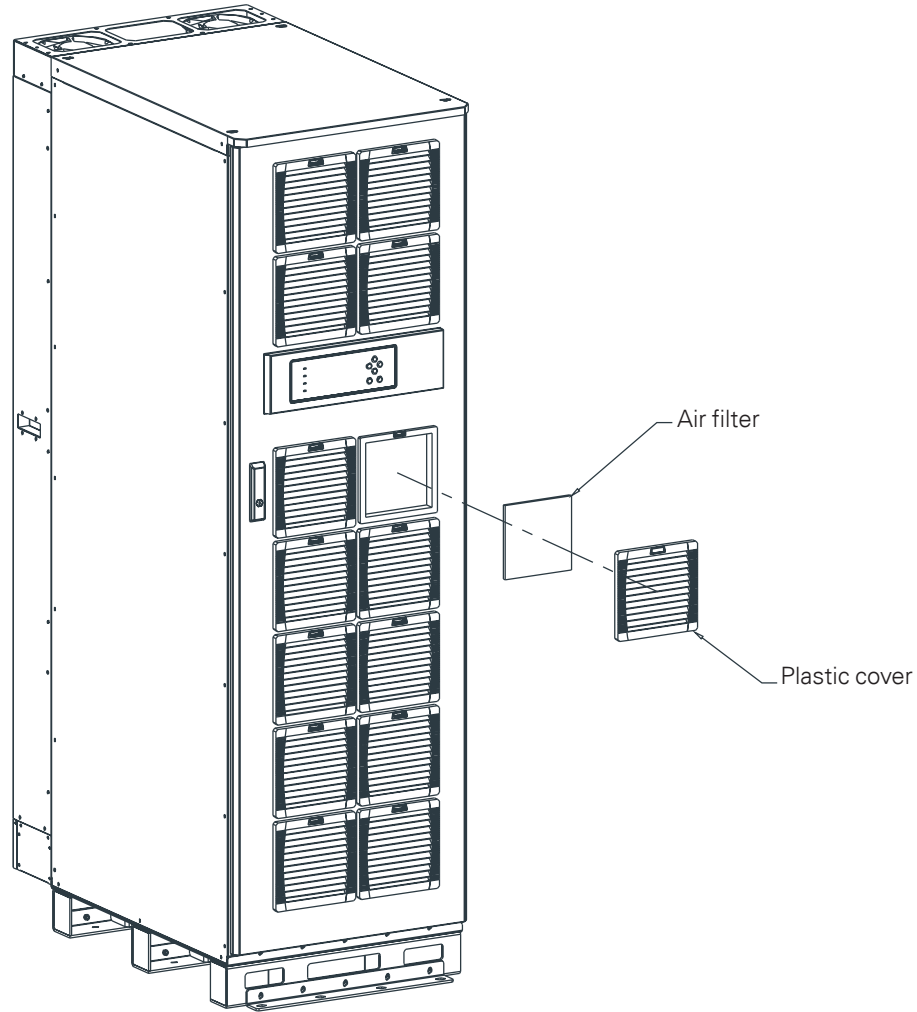

Figure 8-1. Air Filter Location

8.2.3 PERIODIC Maintenance

Periodic inspections of the UPS should be made to determine if components, wiring, and connections exhibit evidence of overheating. Particular attention should be given to the compression lug connections. Maintenance procedures should specify that the compression lug connections be retorqued to values listed in this manual.

8.2.4 ANNUAL Maintenance

Annual preventive maintenance should be performed only by authorised service personnel familiar with maintenance and servicing of the UPS system. Contact an Eaton service representative for more information about service offerings.

8.2.5 BATTERY Maintenance

Contact an Eaton service representative for battery maintenance. Battery replacement and maintenance should be performed only by authorised service personnel.

8.3 Installing Batteries



NOTE There is no manual DC disconnect device within the UPS.

Install batteries in accordance with the battery and battery system manufacturer's instructions.

8.4 Recycling the Used Battery or UPS

Contact your local recycling or hazardous waste centre for information on proper disposal of the used battery or UPS.

WARNING

- Do not dispose of the battery or batteries in a fire. Batteries may explode. Proper disposal of batteries is required. Refer to your local codes for disposal requirements.
 - Do not open or mutilate the battery or batteries. Released electrolyte is harmful to the skin and eyes. It may be toxic.
 - A battery can cause electrical shock, burn from high short-circuit current, or fire. Observe proper precautions.
-

ATTENTION!

- Une batterie peut présenter un risque de choc électrique, de brûlure, ou d'incendie. Suivre les précautions qui s'imposent.
 - Pour le remplacement, utiliser le même nombre et modèle des batteries.
 - L'élimination des batteries est règlementée. Consulter les codes locaux à cet effet.
-

CAUTION

Do not discard the UPS or the UPS batteries in the trash. This product contains sealed, lead-acid batteries (or nickel-cadmium batteries) and must be disposed of properly. For more information, contact your local recycling/reuse or hazardous waste centre.

CAUTION

Do not discard waste electrical or electronic equipment (WEEE) in the trash. For proper disposal, contact your local recycling/reuse or hazardous waste centre.

8.5 Maintenance Training

A basic training course, available from Eaton Corporation, gives you a competent working knowledge of the UPS system operation and teaches you how to perform first level corrective maintenance. For more information about training and other services, contact the Help Desk (see paragraph 1.8).

Chapter 9 Product Specifications

9.1 Model Numbers

The UPS is housed in a free-standing cabinet with safety shields behind the door. The UPS is available in 50 or 60 Hz with various output power ratings.

Table 9-1. UPS Model

Models	Power Rating	Frequency	Description
Eaton 9EHD-31-40/20	20 kVA	50/60 Hz	9EHD---9EHD UPS Series
Eaton 9EHD-33-40/20	20 kVA	50/60 Hz	31 --- Three-phase input, Single output.
Eaton 9EHD-31-40/30	30 kVA	50/60 Hz	33 ---Three-phase input, Three-phase output.
Eaton 9EHD-33-40/30	30 kVA	50/60 Hz	
Eaton 9EHD-31-40/40	40 kVA	50/60 Hz	
Eaton 9EHD-33-40/40	40 kVA	50/60 Hz	

9.2 Specifications

The following sections detail the input, output, environmental, and battery specifications for the UPS.

Table 9-2. UPS Environmental

Operating Temperature	UPS: 0 to 40°C (32 to 104°F) without derating. The recommended operating temperature is 25°C (77°F). Battery: 5 - 25°C
Storage Temperature	-25 to +70°C, excluding batteries (prolonged storage above 40°C causes rapid battery self-discharge)
Operating Altitude	Maximum 1000m (3300 ft) at 40°C without derating
Relative Humidity (operating and storage)	5% to 95% maximum noncondensing
Acoustical Noise	< 60 dB (Rear exhaust) at a 1m distance, per ISO 7779 < 72 dB (Top exhaust) at a 1m distance, per ISO 7779
EMC	Meets IEC 62040-2 C3

Table 9-3. UPS Input

Operating Input Voltage	380/400/415 Vac
Input Voltage Range	(-15%, +20%) at 100% load
	(-50%, +20%) at 50% load
Operating Input Frequency Range	50/60 Hz
Input Frequency Range	40-72Hz
Operating Input Current	See Table 3-5. Adjustable
Input Current Harmonic Content	5% THD at full load
Power Factor	Minimum 0.99
Line Surges	6 kV OC, 3 kA SC per ANSI 62.41 and IEC 801 4
Battery Voltage	432 Vdc External
Battery Charging Capacity (432 Vdc)	16A maximum at any load up to 100% load for 20-40 kVA UPS

Table 9-4. UPS Output

UPS Output Capacity	100% rated current
Output Voltage Regulation	± 1% (10% to 100% load)
Nominal Output Voltage Three-phase input, Single output	220 Vac, 230 Vac and 240 Vac nominal
Nominal Output Voltage Three-phase input, Three-phase output	380 Vac, 400 Vac and 415 Vac nominal
Output Voltage Harmonic Content	2% maximum THD (linear load)
	5% maximum THD (nonlinear load)
Output Current	See Table 3-5 and Table 3-6
Output Voltage Balance	< 2% for 100% maximum load imbalance (linear load)
Output Voltage Phase Displacement	< 2.5° for 100% maximum load imbalance (linear load)
Frequency Regulation	0.1 Hz free running
Synchronous to Bypass	± 3 Hz (default setting)
Frequency Slew Rate	3 Hz per second (default setting)
Load Compatibility	0.9 PF Leading
	0.7 PF Leading
Overload Capability	102-105% load 60 minutes
	106-126% load 10 minutes
	126-150% load 1 minute
	>150% load 500msec

