

NOTES:
 1 RCD: xxx/-/xxx STD: xxx/-/xxx Key Dimension: *
 2 RCD: Required Control Dimension. These Dimensions need Process control & capability (initial and ongoing), 100% inspection, poke yoke, etc. as appropriate.
 3 STD: Statistically Toleranced Dimension. These Dimensions need demonstration of ongoing process capability (Cpk/PPK).
 * Key Dimension. These Dimensions are defined by ME/Mfg. and need inspection as appropriate. If you want more information, please review the criterions of <TC-RDW-18> and <TC-QAW-40>.

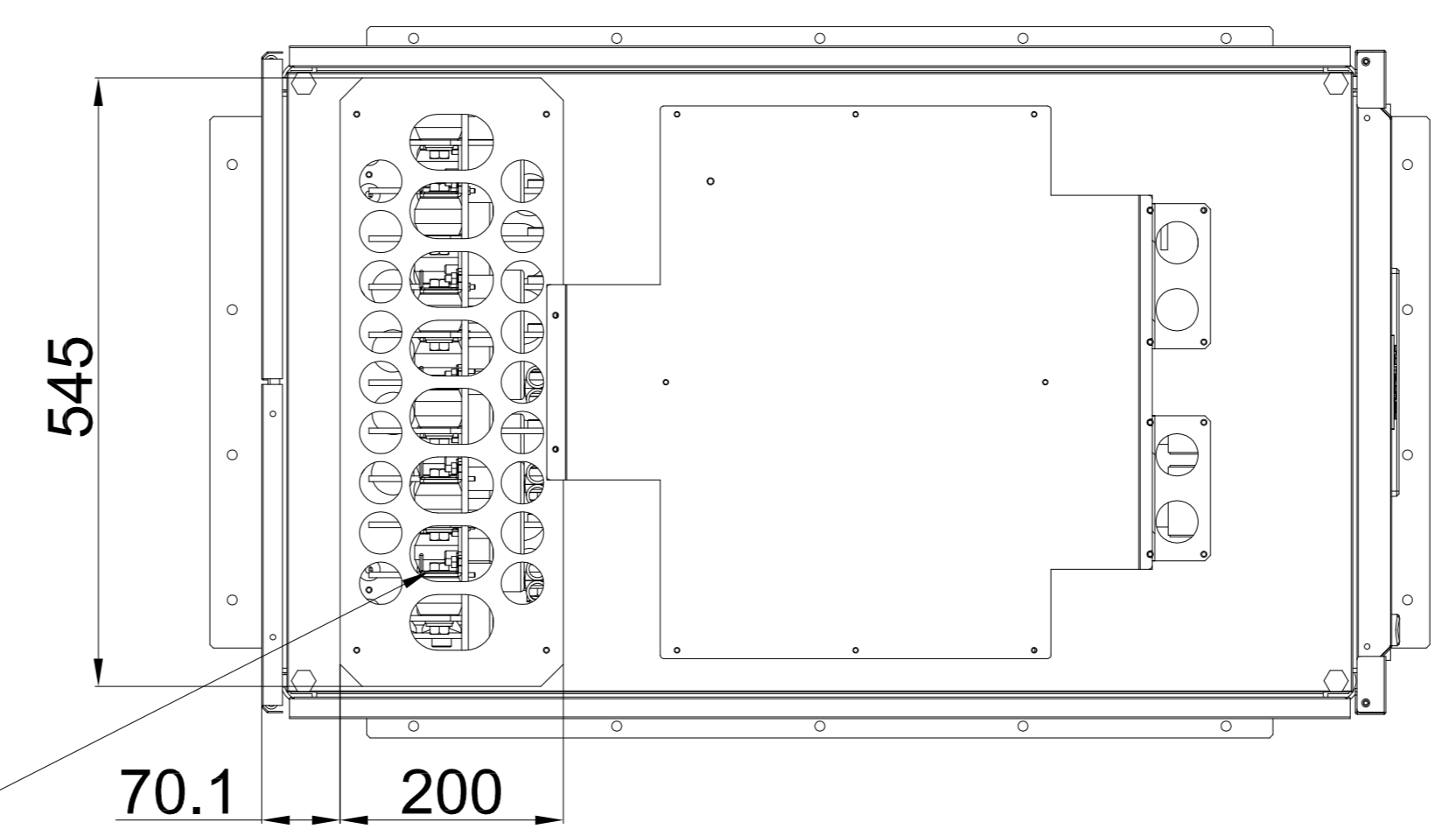

Top cable entrance

TOP VIEW

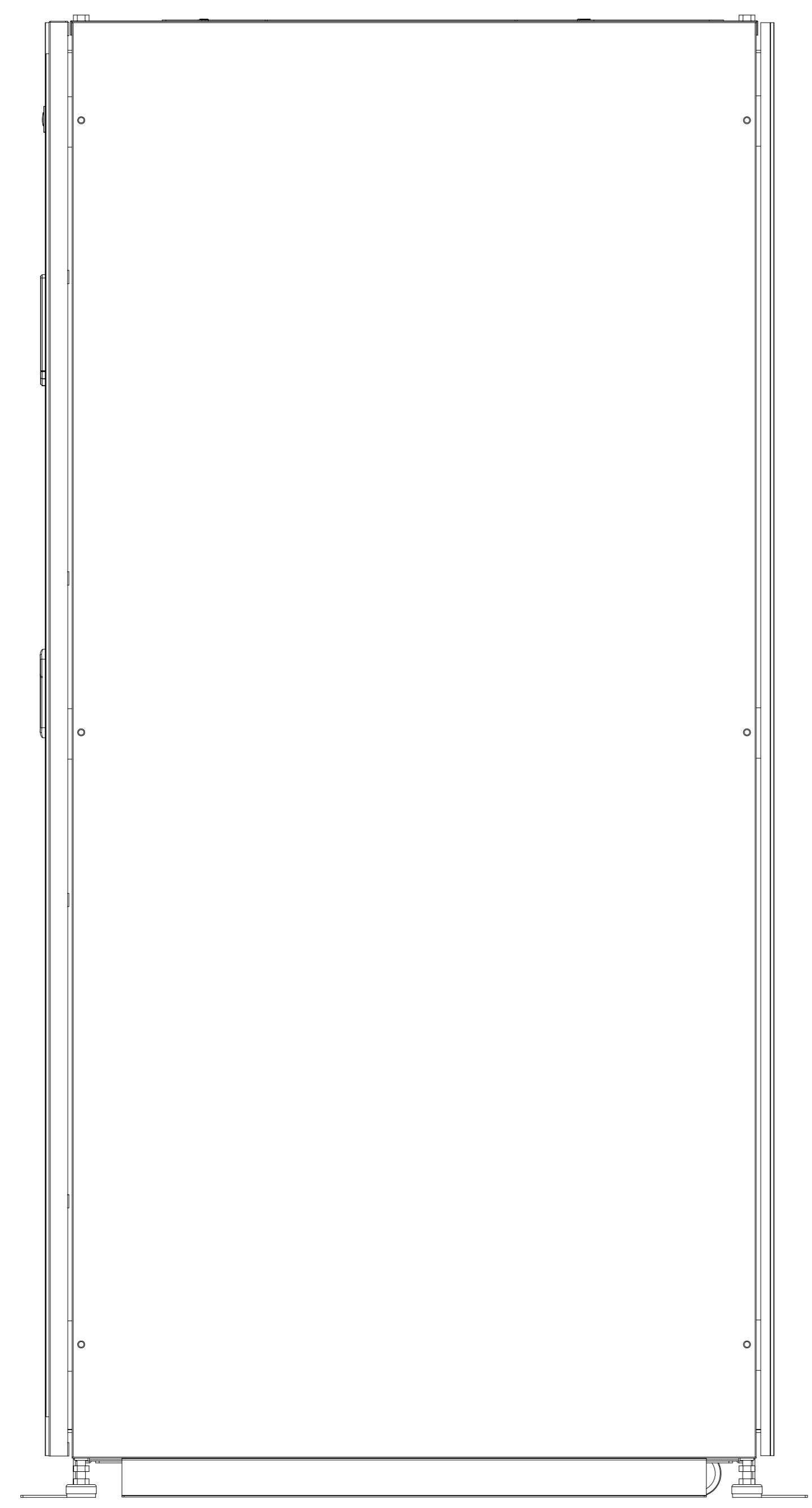

SIDE VIEW

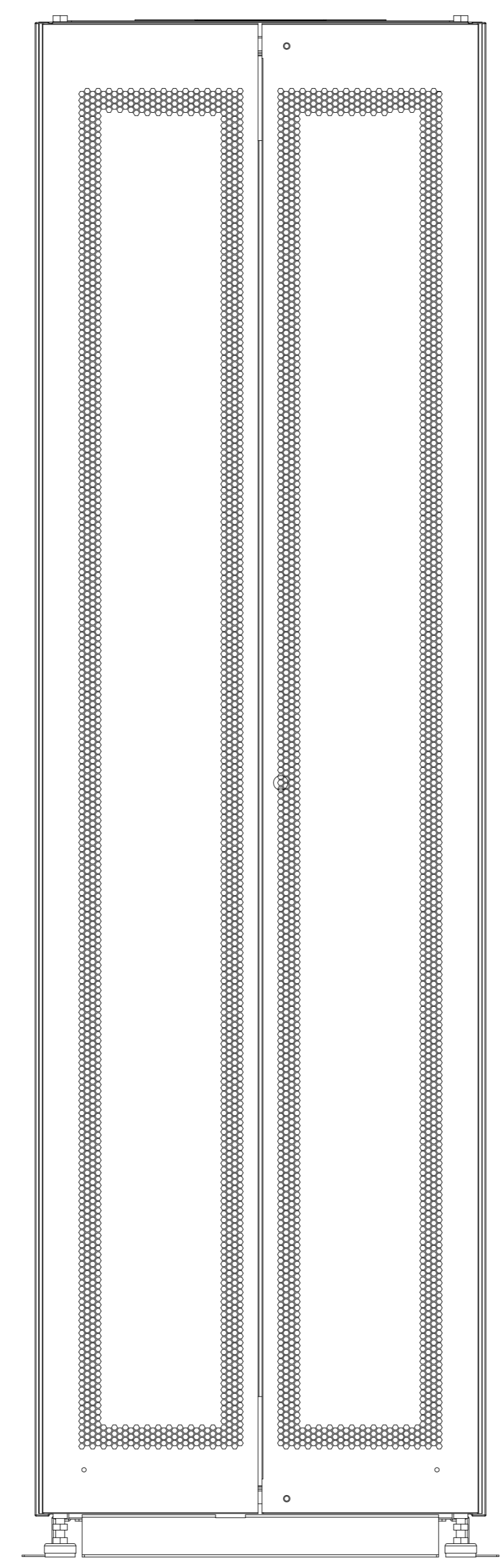

REAR VIEW

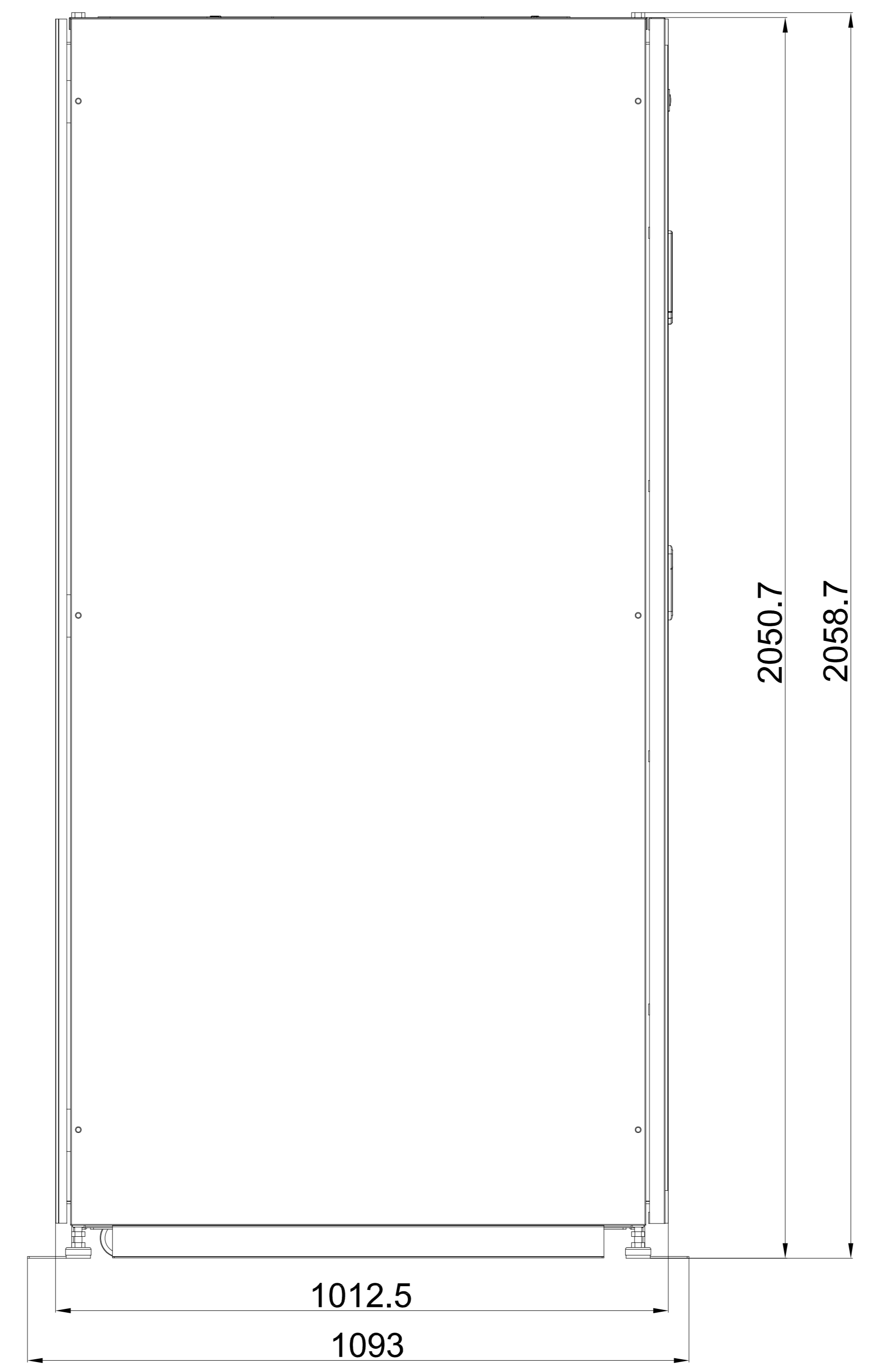

SIDE VIEW

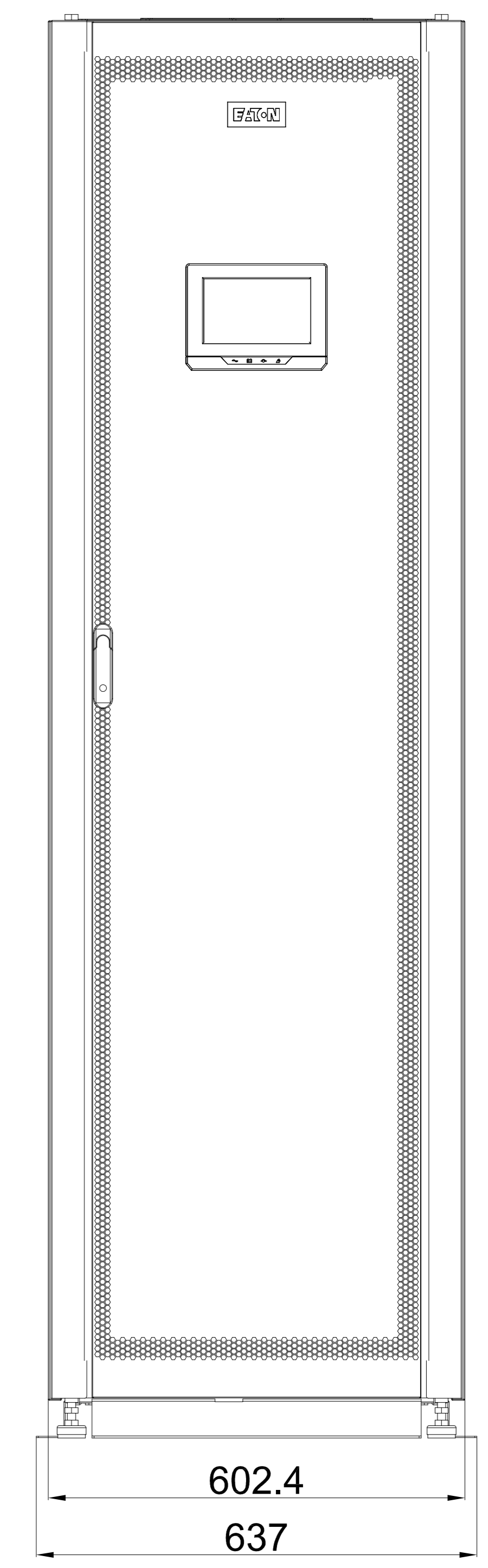

FRONT VIEW

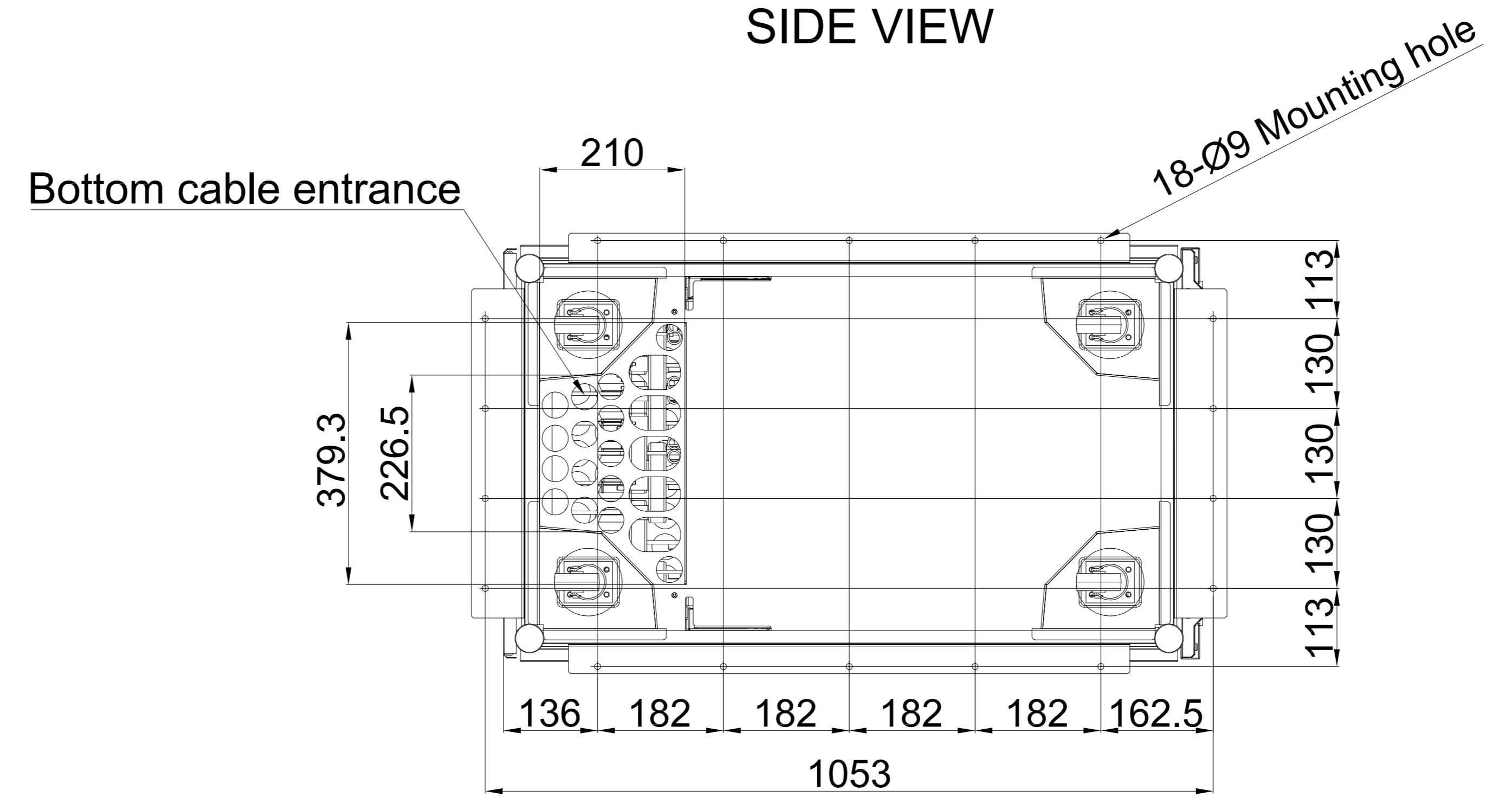

BOTTOM VIEW

METRIC		EATON CORPORATION		EATON	
DESCRIPTION: 93PR GA DRAWING					
DESIGNED BY: Roger Vito	DATE:	REVISED BY:	DATE:	REVISED BY:	DATE:
CHECKED BY:	APPROVED BY:	DESCRIPTION TITLE:	93PR GA DRAWING	SCALE:	1:1
DRAWN BY:			STATE:	SHEET:	1 OF 1
<small>THIS DOCUMENT IS UNCLASSIFIED AND UNCONTROLLED. IT IS THE PROPERTY OF EATON CORPORATION AND IS LOANED TO YOU AND IS SUBJECT TO RETURN TO EATON CORPORATION. IT IS NOT TO BE REPRODUCED OR TRANSMITTED IN ANY FORM OR BY ANY MEANS, ELECTRONIC OR MECHANICAL, INCLUDING PHOTOCOPYING, RECORDING, OR BY ANY INFORMATION STORAGE AND RETRIEVAL SYSTEM. WITHOUT THE WRITTEN PERMISSION OF EATON CORPORATION. © 2008 EATON CORPORATION. ALL RIGHTS RESERVED.</small>					