

Eaton® 93PM-L Sidecar Integrated Accessory Cabinet

60 kW (208V) Top Entry Wiring Sidecar

60 kW (208V) SIAC-B

120 kW (208V) Top Entry Wiring Sidecar

120 kW (208V) SIAC-B

Installation and Operation Manual



Powering Business Worldwide

p/n: P-164000822
Revision 01

IMPORTANT SAFETY INSTRUCTIONS SAVE THESE INSTRUCTIONS

This manual contains important instructions that you should follow during installation and maintenance of the UPS and batteries. Please read all instructions before operating the equipment and save this manual for future reference.

CONSIGNES DE SÉCURITÉ IMPORTANTES – CONSERVER CES INSTRUCTIONS

Ce manuel comporte des instructions importantes que vous êtes invité à suivre lors de toute procédure d'installation et de maintenance des batteries et de l'onduleur. Veuillez consulter entièrement ces instructions avant de faire fonctionner l'équipement et conserver ce manuel afin de pouvoir vous y reporter ultérieurement.



IMPORTANT

To ensure you have the most up-to-date content and information for this product, please review the latest manual revision on our website, www.eaton.com/93PM.

Eaton reserves the right to change specifications without prior notice. Eaton is a registered trademark of Eaton. KIRK is a registered trademark of Kirk Key Interlock company, LLC, a subsidiary of Halma plc. National Electrical Code and NEC are registered trademarks of National Fire Protection Association, Inc. Superflex is a registered trademark of LUTZE Systematic Technology. All other trademarks are property of their respective companies.

©Copyright 2018 Eaton, Raleigh, NC, USA. All rights reserved. No part of this document may be reproduced in any way without the express written approval of Eaton.

Table of Contents

1 Introduction	1
1.1 Introduction	1
1.2 Installation Features	1
1.3 Model Configurations	2
1.4 Using This Manual	5
1.5 Conventions Used in This Manual	6
1.6 Symbols, Controls, and Indicators	6
1.7 For More Information	7
1.8 Getting Help	7
1.9 Equipment Registration	8
2 Safety	9
2.1 Safety Warnings	9
3 Installation Plan and Unpacking	11
3.1 Installation Plan and Unpacking	11
3.1.1 Basic Installation Overview	11
3.2 Creating an Installation Plan	11
3.3 Preparing the Site	11
3.3.1 Environmental and Installation Considerations	11
3.3.2 Floor Mounting Brackets	17
3.3.3 SIAC Power Wiring Preparation	20
3.3.4 SIAC-B Interface Wiring Preparation	27
3.4 Inspecting and Unpacking the SIAC	27
4 Installation	29
4.1 Preliminary Installation Information	29
4.2 Unloading the Field Installed SIAC from the Pallet	29
4.3 Mechanically Joining the UPS Cabinet and SIAC	31
4.4 Electrically Connecting the UPS Cabinet and SIAC-B	33
4.4.1 Installing SIAC-B Internal Power Wiring	33
4.5 Removing and Reinstalling the Factory Installed SIAC-B	37
4.5.1 Electrically Disconnecting the UPS Cabinet and SIAC-B	37
4.5.2 Mechanically Disconnecting the UPS Cabinet and SIAC-B	37
4.5.3 Mechanically Rejoining the UPS Cabinet and SIAC-B	38
4.5.4 Electrically Reconnecting the UPS Cabinet and SIAC-B	38
4.6 Unloading the Factory Installed SIAC-B from the Pallet and Mechanical Installation	39
4.7 Two-Hole Barrel Lug Terminations to Bus Bar Installation	40
4.8 Installing SIAC-B External Power Wiring	40
4.9 Installing SIAC-B Interface Connections	43
4.9.1 Installing Sidecar Breaker Monitoring Connections	43

Table of Contents

4.10 Initial Startup.....	45
4.11 Completing the Installation Checklist.....	45
5 Operation.....	49
5.1 SIAC-B Operating Instructions.....	49
5.1.1 Sidecar Integrated Accessory Cabinet-Bypass.....	49
5.1.1.1 Circuit Breakers.....	49
5.1.1.2 Using the UPS when an SIAC-B is Installed.....	49
5.1.1.3 Transferring the UPS to Maintenance Bypass using an SIAC-B.....	51
5.1.1.4 Transferring the UPS from Maintenance Bypass using an SIAC-B.....	51
6 Onelines and Schematics.....	53
6.1 UPS with Sidecar Online Schematics.....	53
7 Maintenance.....	57
7.1 Maintenance.....	57
7.1.1 Important Safety Instructions.....	57
7.2 Performing Preventive Maintenance.....	57
7.2.1 DAILY Maintenance.....	57
7.2.2 PERIODIC Maintenance.....	57
7.2.3 ANNUAL Maintenance.....	57
7.3 Maintenance Training.....	58
8 Product Specifications.....	59
8.1 Product Specifications.....	59
8.1.1 Models.....	59
8.2 Specifications.....	59
8.2.1 Input.....	59
8.2.2 Output.....	59
8.2.3 Environmental and Safety Specifications.....	60
9 Warranty.....	61
9.1 Warranty.....	61

List of Figures

Figure 1.	Eaton 93PM-L 60 kW UPS with Left or Right Mounted Top Entry Wiring Sidecar	3
Figure 2.	Eaton 93PM-L 120 kW UPS with Left or Right Mounted Top Entry Wiring Sidecar.....	4
Figure 3.	Eaton 93PM-L 60 kW or 120 kW UPS with Left or Right Mounted SIAC-B	5
Figure 4.	93PM-L 60 kW UPS with Top Entry Sidecar Dimensions (Front Views)	13
Figure 5.	93PM-L 60 kW UPS with Top Entry Sidecar Dimensions (Top and Bottom Views).....	14
Figure 6.	93PM-L 120 kW UPS with Top Entry Wiring Sidecar Dimensions (Front View).....	15
Figure 7.	93PM-L 60 kW and 120 kW UPS with SIAC-B Dimensions (Front View)	16
Figure 8.	93PM-L 60 and 120 kW UPS with SIAC-B Dimensions (Top and Bottom Views)	17
Figure 9.	93PM-L 60 and 120 kW UPS with SIAC Floor Mounting Bracket Mounting Dimensions (Rear View)	18
Figure 10.	93PM-L 60 and 120 kW UPS with SIAC Floor Mounting Bracket Mounting Dimensions (Top View).....	19
Figure 11.	Eaton 93PM-L 60 kW or 120 kW Sidecar as Shipped on Pallet.....	28
Figure 12.	Removing the Pallet Skids and Supports – Eaton 93PM-L Field Installed SIAC	30
Figure 13.	SIAC to Cabinet Tie Strap Locations	33
Figure 14.	Eaton 93PM-L 60 kW and 120 kW SIAC-B Left or Right-Mounted Bypass Terminal Locations.....	35
Figure 15.	Maintenance Isolation Breaker (MIS) Terminal Detail	36
Figure 16.	Bypass Input Breaker (BIB) Terminal Detail	36
Figure 17.	Rectifier Input Breaker (RIB) Terminal Detail.....	37
Figure 18.	Typical Bus Bar Barrel Lug Mounting – Hardware Assembly Sequence	40
Figure 19.	Eaton 93PM-L 60 kW and 120 kW SIAC-B Conduit Landing Wire Entry Locations	42
Figure 20.	Sidecar TB1 and TB2 Terminal Locations.....	44
Figure 21.	Eaton 93PM-L SIAC-B Breaker Locations	50
Figure 22.	Eaton 93PM-L 60 kW UPS with Top Entry Sidecar System Online.....	53
Figure 23.	Eaton 93PM-L 60 kW UPS with SIAC-B (Bypass Sidecar) System Online	54
Figure 24.	Eaton 93PM-L 120 kW UPS with Top Entry Sidecar System Online	55
Figure 25.	Eaton 93PM-L 120 kW UPS with SIAC-B (Bypass Sidecar) System Online	56

List of Figures

List of Tables

Table 1.	Eaton 93PM-L 60 kW Sidecar Cabinet Weights	12
Table 2.	Eaton 93PM-L 120 kW Sidecar Cabinet Weights	12
Table 3.	External Power Wiring Recommendations: Eaton 93PM-L 60 kW and 120 kW SIAC-B (208/208) — Two and Three Breaker Maintenance Bypass	21
Table 4.	External Power Wiring Recommendations: Eaton 93PM-L 60 kW and 120 kW SIAC-B (220/220) — Two and Three Breaker Maintenance Bypass	22
Table 5.	External Power Wiring Recommendations: Eaton 93PM-L 60 kW and 120 kW SIAC-B (Single Input Bypass 220/208) — Two and Three Breaker Maintenance Bypass	23
Table 6.	External Power Wiring Recommendations: Eaton 93PM-L 60 kW and 120 kW SIAC-B (208/208) — Four Breaker Maintenance Bypass	24
Table 7.	External Power Wiring Recommendations: Eaton 93PM-L 60 kW and 120 kW SIAC-B (220/220) — Four Breaker Maintenance Bypass	25
Table 8.	External Input Power Cable Terminations for the 93PM-L 60 kW and 120 kW SIAC-B.....	26
Table 9.	Sidecar MIS and RIB Breaker Monitoring Connection and Wire Terminations	43
Table 10.	SIAC-B Circuit Breaker Position Settings.....	49

List of Tables

Chapter 1 Introduction

1.1 Introduction

The Eaton® 93PM-L 60 kW and 120 kW Top Entry Wiring Sidecar and the Sidecar Integrated Accessory Cabinet-Bypass (SIAC-B) are designed for use with the Eaton 93PM-L 60 kW and 120 kW UPS systems. The Top Entry Wiring Sidecar provides the customer with a top entry wiring installation option. The SIAC-B provides maintenance bypass functions with configurable features, enabling adaptation and expansion without costly electrical rework.



NOTE

Startup and operational checks must be performed by an authorized Eaton Customer Service Engineer, or the warranty terms specified in paragraph [9.1 Warranty](#) become void. This service is offered as part of the sales contract for the UPS. Contact an Eaton service representative in advance (a minimum two-week notice is required) to reserve a preferred startup date.

1.2 Installation Features

The Top Entry Wiring Sidecar and the SIAC-B are housed in a single cabinet that is attached to and directly integrated with the UPS cabinet. The cabinet is mounted on the left or right side of the UPS based on the ordered configuration. The sidecar matches the UPS cabinet in style and color. It has safety shields behind the removable front panel for hazardous voltage protection. Power wiring between the UPS and sidecar is factory installed unless the sidecar was shipped separately from the UPS. Output power wiring to the critical load is routed using external conduit.

The following descriptions provide a brief overview of the sidecar functions:

- Top Entry Wireway Sidecar: Empty sidecar cabinet used for top entry wiring.
- Two breaker configuration SIAC-B: The bypass sidecar contains only a Maintenance Bypass (MBP) and Maintenance Isolation (MIS) breaker. This allows Maintenance bypass for system repair or maintenance. The critical load is NOT protected in the Maintenance bypass mode.
- Three breaker configuration (used with single-feed systems) SIAC-B: Maintenance Bypass (MBP) and Maintenance Isolation (MIS) breakers, and a Bypass Input Breaker (BIB) enable power to completely bypass the UPS. The UPS can then be safely serviced or replaced without interrupting power to critical systems.
- Four breaker configuration (used with single-feed systems with backfeed protection or dual-feed systems) SIAC-B: Maintenance Bypass (MBP) and Maintenance Isolation (MIS) breakers, and a Bypass Input Breaker (BIB) enable power to completely bypass the UPS. A Rectifier Input Breaker (RIB) provides a convenient method for removing power from the UPS when using the maintenance bypass to supply the load. The UPS can then be safely serviced or replaced without interrupting power to critical systems.



NOTE

The four breaker SIAC-B is shipped configured as a single-feed system with a jumper installed between the Bypass Input Terminals and the Rectifier Input Breaker (RIB). The Bypass may be configured as a dual-feed system by removing the jumper and installing the second source wiring to the RIB.

[Figure 1](#) and [Figure 3](#) show the sidecar mounted to the UPS cabinet.

1.3 Model Configurations

The following model configurations are available:

- Eaton 93PM-L 60 kW Top Entry Wiring Sidecar
 - Right-mounted empty sidecar
 - Left-mounted empty sidecar
- Eaton 93PM-L 120 kW Top Entry Wiring Sidecar
 - Right-mounted empty sidecar
 - Left-mounted empty sidecar
- Eaton 93PM-L 60 kW SIAC-B, Eaton 93PM-L 120 kW SIAC-B
 - Right-mounted two breaker configuration containing a MBP with auxiliary contacts and MIS
 - Right-mounted three breaker configuration containing a MBP with auxiliary contacts, a MIS, and a BIB
 - Right-mounted four breaker configuration containing a MBP with auxiliary contacts, a MIS, a BIB, and a RIB
 - Left-mounted two breaker configuration containing a MBP with auxiliary contacts and MIS
 - Left-mounted three breaker configuration containing a MBP with auxiliary contacts, a MIS, and a BIB
 - Left-mounted four breaker configuration containing a MBP with auxiliary contacts, a MIS, a BIB, and a RIB

Figure 1. Eaton 93PM-L 60 kW UPS with Left or Right Mounted Top Entry Wiring Sidecar

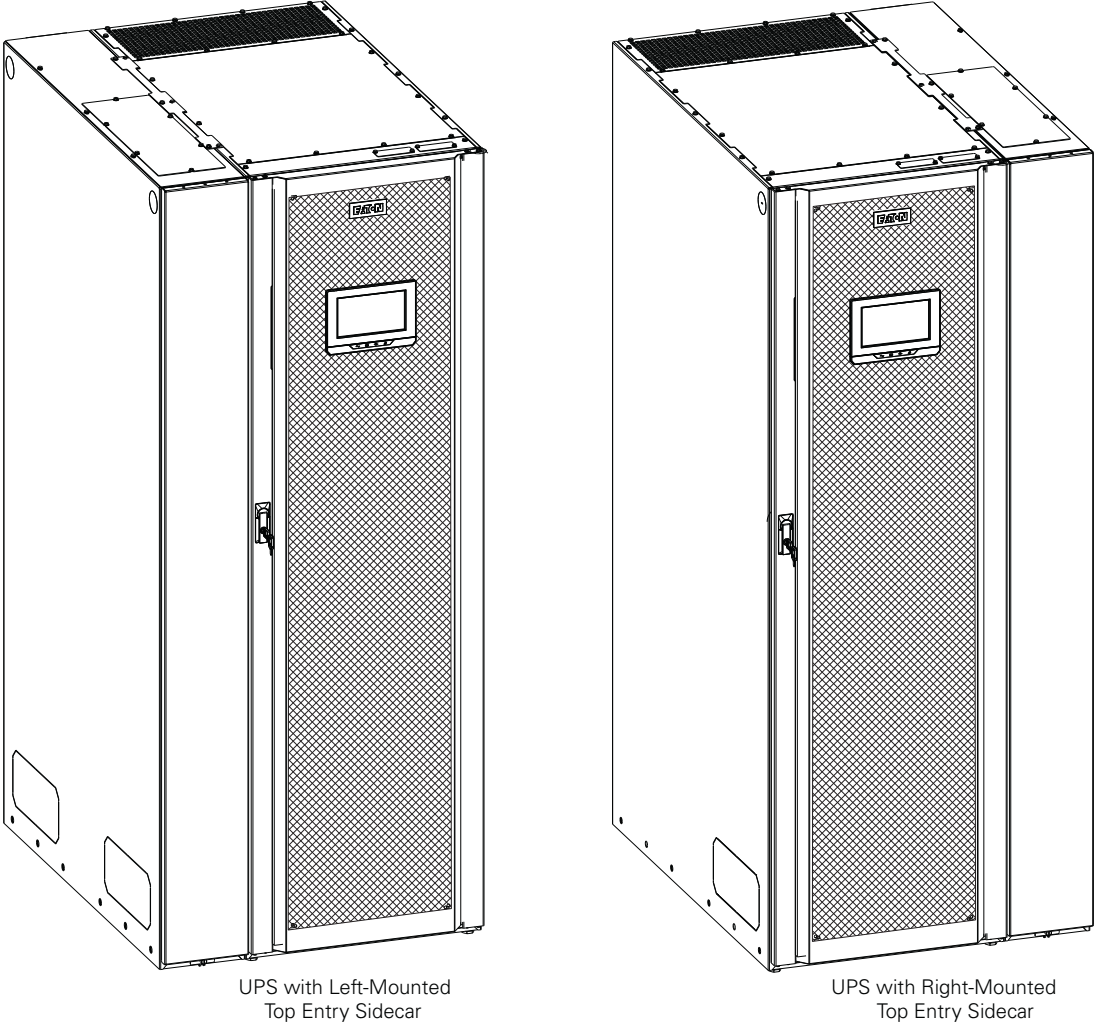
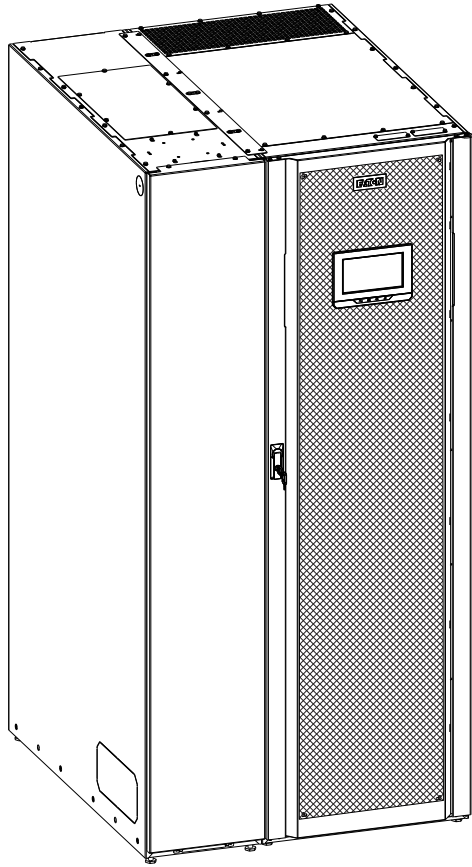
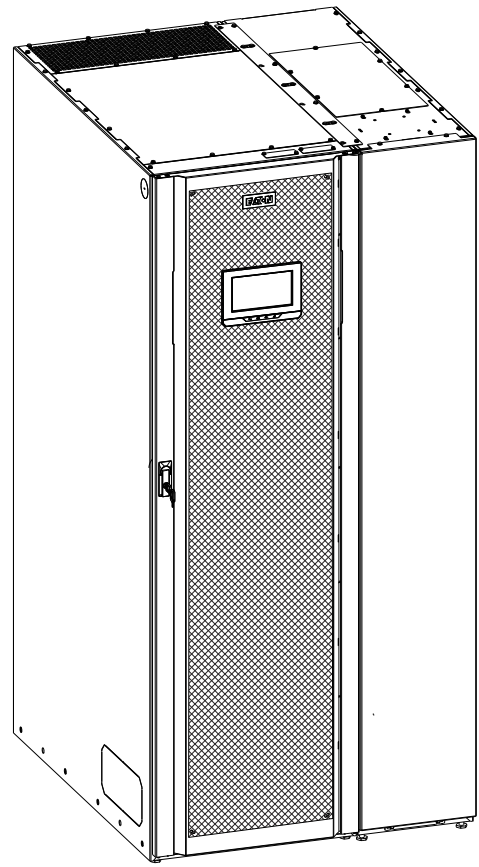

Figure 2. Eaton 93PM-L 120 kW UPS with Left or Right Mounted Top Entry Wiring Sidecar



UPS with Left-Mounted
Top Entry Sidecar

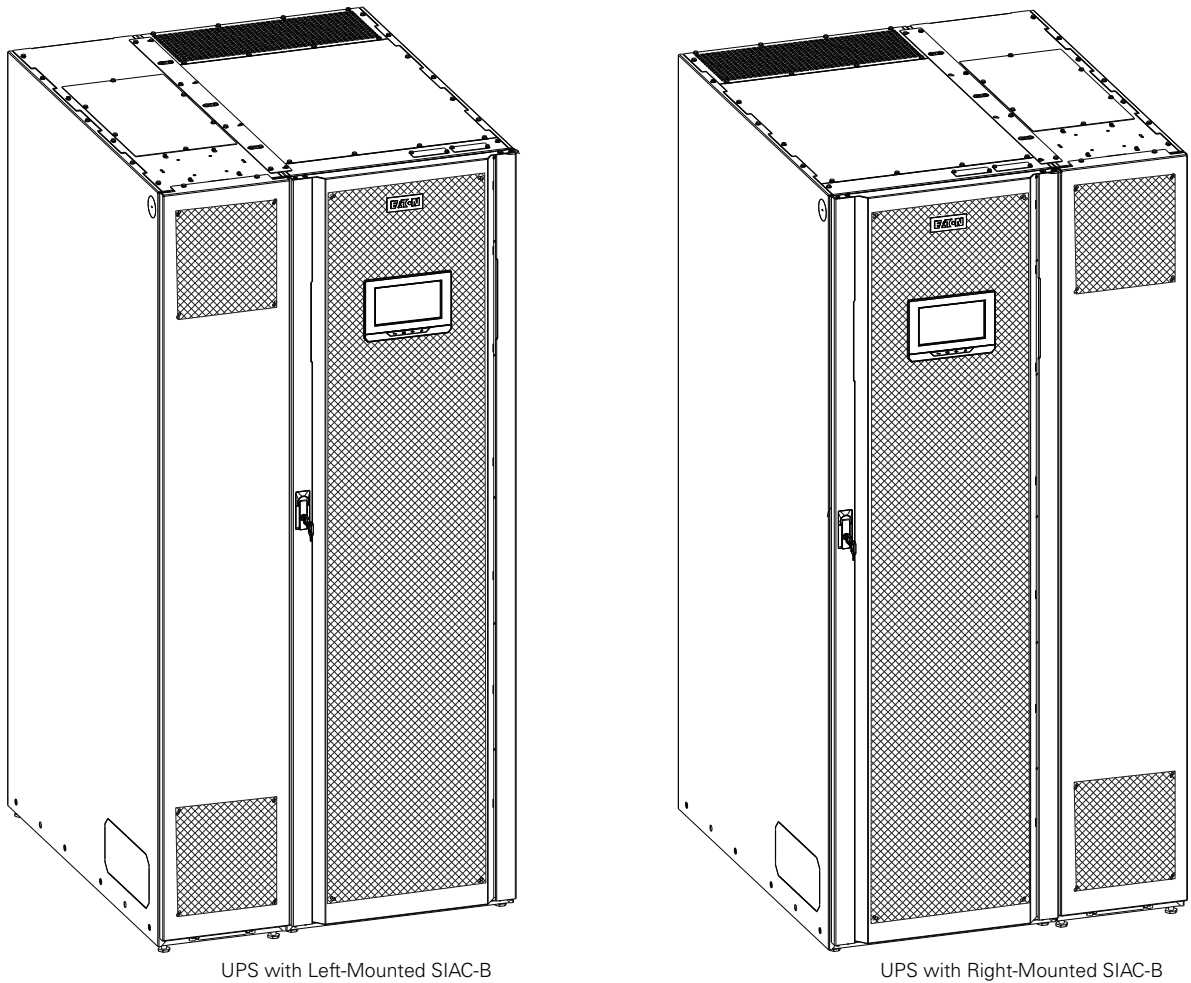

UPS with Right-Mounted
Top Entry Sidecar

Figure 3. Eaton 93PM-L 60 kW or 120 kW UPS with Left or Right Mounted SIAC-B

1.4 Using This Manual

This manual describes how to install the IAC-B and is divided into chapters. Read and understand the procedures described to ensure trouble-free installation and operation.

Read through each procedure before beginning work. Perform only those procedures that apply to the system being installed or operated.

1.5 Conventions Used in This Manual

This manual uses these type conventions:

- **Bold type** highlights important concepts in discussions, key terms in procedures, and menu options, or represents a command or option that you type or enter at a prompt.
- *Italic type* highlights new terms where they are defined.
- `Screen type` represents information that appears on the screen or LCD.

Icon	Description
NOTE	Information notes provide pertinent information about important features or instructions.
[Keys]	Brackets are used when referring to a specific key, such as [Enter] or [Ctrl].

In this manual, the term *UPS* refers only to the UPS cabinet and its internal elements. The term *UPS system* refers to the entire power protection system – the UPS cabinet, an external battery system, and options or accessories installed.

The term *line-up-and-match* refers to accessory cabinets that are physically located adjacent to the UPS. The term *standalone* refers to accessory cabinets that are located separate from the UPS.

1.6 Symbols, Controls, and Indicators

The following are examples of symbols used on the UPS or accessories to alert you to important information:



RISK OF ELECTRIC SHOCK - Observe the warning associated with the risk of electric shock symbol.



CAUTION: REFER TO OPERATOR'S MANUAL - Refer to your operator's manual for additional information, such as important operating and maintenance instructions.



This symbol indicates that you should not discard the UPS or the UPS batteries in the trash. This product contains sealed, lead-acid batteries and must be disposed of properly. For more information, contact your local recycling/reuse or hazardous waste center.



This symbol indicates that you should not discard waste electrical or electronic equipment (WEEE) in the trash. For proper disposal, contact your local recycling/reuse or hazardous waste center.

1.7 For More Information

Refer to the *Eaton 93PM-L UPS 20–60 kW Installation and Operation Manual* and the *Eaton 93PM-L UPS 20–120 kW Installation and Operation Manual* for the following additional information:

- UPS, optional components, and accessory installation instructions, including site preparation, planning for installation, and wiring and safety information. Detailed illustrations of cabinets and optional accessories with dimensional and connection point drawings are provided.
- UPS operation, including UPS controls, functions of the UPS, standard features and optional accessories, procedures for starting and stopping the UPS, and information about maintenance and responding to system events.
- Communication capabilities of the UPS system.

Visit www.eaton.com/powerquality or contact an Eaton service representative for information on how to obtain copies of these manuals.

1.8 Getting Help

If help is needed with any of the following:

- Scheduling initial startup
- Regional locations and telephone numbers
- A question about any of the information in this manual
- A question this manual does not answer

Please call the Customer Reliability Center at:

United States:	1-800-843-9433
Canada:	1-800-461-9166 ext 2200
All other countries:	Call your local service representative

Please use the following e-mail address for manual comments, suggestions, or to report an error in this manual:

E-ESSDocumentation@eaton.com

1.9 Equipment Registration

Please visit www.eaton.com/pq/register to register your new Eaton UPS / Eaton UPS Accessory.

Model Number:

Serial Number:

Chapter 2 Safety

2.1 Safety Warnings

IMPORTANT SAFETY INSTRUCTIONS SAVE THESE INSTRUCTIONS

This manual contains important instructions that should be followed during installation and maintenance of the UPS system and batteries. Read all instructions before operating the equipment and save this manual for future reference.

The UPS system is designed for industrial or computer room applications, and contains safety shields behind the door and front panels. However, the UPS system is a sophisticated power system and should be handled with appropriate care.



DANGER

This UPS system contains LETHAL VOLTAGES. All repairs and service should be performed by AUTHORIZED SERVICE PERSONNEL ONLY. There are NO USER SERVICEABLE PARTS inside the UPS. Failure to follow these instructions may result in serious injury or death.



WARNING

-
- The UPS system is powered by its own energy source (batteries). The output terminals may carry live voltage even when the UPS is disconnected from an AC source.
 - To reduce the risk of fire or electric shock, install this UPS system in a temperature and humidity controlled, indoor environment, free of conductive contaminants. Ambient temperature must not exceed 40°C (104°F). Do not operate near water or excessive humidity (95% maximum). The system is not intended for outdoor use.
 - As a result of the connected loads, high leakage current is possible. Connection to earth ground is required for safety and proper product operation. Do not check UPS system operation by any action that includes removal of the earth (ground) connection with loads attached.
 - Ensure all power is disconnected before performing installation or service.
 - ELECTRIC ENERGY HAZARD. Do not attempt to alter any UPS system or battery wiring or connectors. Attempting to alter wiring may result in serious injury or death.
-

 **CAUTION**

- Installation or servicing should be performed by qualified service personnel knowledgeable of UPS and battery systems, and required precautions. Keep unauthorized personnel away from equipment. Consider all warnings, cautions, and notes before installing or servicing equipment.
 - Keep the accessory cabinet doors closed and front panels installed to ensure proper cooling airflow and to protect personnel from dangerous voltages inside the unit.
 - Do not install or operate the UPS system close to gas or electric heat sources.
 - The operating environment should be maintained within the parameters stated in this manual.
 - Keep surroundings uncluttered, clean, and free from excess moisture.
 - Observe all DANGER, WARNING, and CAUTION notices affixed to the inside and outside of the equipment.
-

Chapter 3 Installation Plan and Unpacking

3.1 Installation Plan and Unpacking

This chapter includes planning for the Eaton 93PM-L 60 kW and 120 kW Top Entry Wiring Sidecar and Sidecar Integrated Accessory Cabinet-Bypass (SIAC-B).

**NOTE**

The SIAC is typically attached to and directly integrated with the UPS cabinet at the factory but it can be ordered and shipped separately from the UPS and installed onsite. This section must be used along with the applicable Eaton 93PM-L UPS Installation and Operation manual during installation planning and unpacking.

3.1.1 Basic Installation Overview

Use the following basic sequence of steps to install the SIAC:

1. Create an installation plan for the UPS with SIAC.
2. Prepare your site for the UPS with SIAC.
3. Inspect and unpack the UPS with SIAC (refer to the applicable Eaton 93PM UPS Installation and Operation manual listed in paragraph [1.7 For More Information](#), for inspection and unpacking instructions).
4. Unload and install the UPS with SIAC.
5. External wire the UPS with SIAC.
6. Complete the Installation Checklist.
7. Have authorized service personnel perform preliminary operational checks and start up the system.

**NOTE**

Startup and operational checks must be performed by an authorized Eaton Customer Service Engineer, or the warranty terms specified in paragraph [9.1 Warranty](#) become void. This service is offered as part of the sales contract for the UPS. Contact an Eaton service representative in advance (usually a two-week notice is required) to reserve a preferred startup date.

3.2 Creating an Installation Plan

Before installing the UPS with the SIAC, read and understand how this manual applies to the system being installed. Use the procedures and illustrations in this section to create a logical plan for installing the UPS with the SIAC.

3.3 Preparing the Site

For the UPS system to operate at peak efficiency, the installation site should meet the environmental parameters outlined in this manual. The operating environment must meet the weight, clearance, and environmental requirements specified for the applicable accessory cabinet. Specifications subject to change.

3.3.1 Environmental and Installation Considerations

The UPS system with a SIAC installation must meet the following guidelines:

- The system must be installed on a level floor suitable for computer or electronic equipment.
- The system must be operated at an altitude no higher than 1500m (5000 ft) without derating. For additional assistance with high altitude operation, contact an Eaton service representative (see paragraph [1.8 Getting Help](#)).
- The system must be installed in a temperature and humidity controlled indoor area free of conductive contaminants.

Failure to follow guidelines may void your warranty.

The basic environmental requirements for operation of the UPS with SIAC-B are:

- Ambient Temperature Range: 5–40°C (41–104°F)
- Recommended Operating Range: 5–40°C (41–104°F)
- Maximum Relative Humidity: 5–95%, noncondensing

The SIAC operating environment must meet the weight requirements shown in [Table 1](#) and [Table 2](#).

Table 1. Eaton 93PM-L 60 kW Sidecar Cabinet Weights

Model Left or Right-Mounted Sidecar	Weight kg (lb)		
	Shipping	Installed	Point Loading
Top Entry Wiring Sidecar (No Breakers)	109 (239)	78 (172)	2 at 39 (86)
Bypass Sidecar (SIAC-B) (2 Breakers)	177 (389)	146 (322)	2 at 73 (161)
Bypass Sidecar (SIAC-B) (3 Breakers)	197 (431)	166 (364)	2 at 83 (182)
Bypass Sidecar (SIAC-B) (4 Breakers)	212 (466)	181 (399)	2 at 91 (200)

NOTE Refer to the applicable Eaton 93PM-L UPS Installation and Operation manual listed in paragraph [1.7 For More Information](#) for the full list of cabinet weights of the various UPS with SIAC configurations.

Table 2. Eaton 93PM-L 120 kW Sidecar Cabinet Weights

Model Left or Right-Mounted Sidecar	Weight kg (lb)		
	Shipping	Installed	Point Loading
Top Entry Wiring Sidecar (No Breakers)	139 (305)	108 (238)	2 at 54 (119)
Bypass Sidecar (SIAC-B) (2 Breakers)	237 (520)	206 (453)	2 at 103 (227)
Bypass Sidecar (SIAC-B) (3 Breakers)	257 (562)	226 (495)	2 at 113 (248)
Bypass Sidecar (SIAC-B) (4 Breakers)	272 (597)	241 (530)	2 at 121 (265)

NOTE Refer to the applicable Eaton 93PM-L UPS Installation and Operation manual listed in paragraph [1.7 For More Information](#) for the full list of cabinet weights of the various UPS with SIAC configurations.

NOTE The clearances required around the SIAC-B are the same as the attached UPS. Refer to the appropriate Eaton 93PM UPS Installation and Operation manual listed in paragraph [1.7 For More Information](#) for the UPS cabinet clearance requirements.

NOTE The Center of Gravity measurements for the UPS and SIAC are detailed in the appropriate Eaton 93PM UPS Installation and Operation manual listed in paragraph [1.7 For More Information](#).

Figure 4. 93PM-L 60 kW UPS with Top Entry Sidecar Dimensions (Front Views)

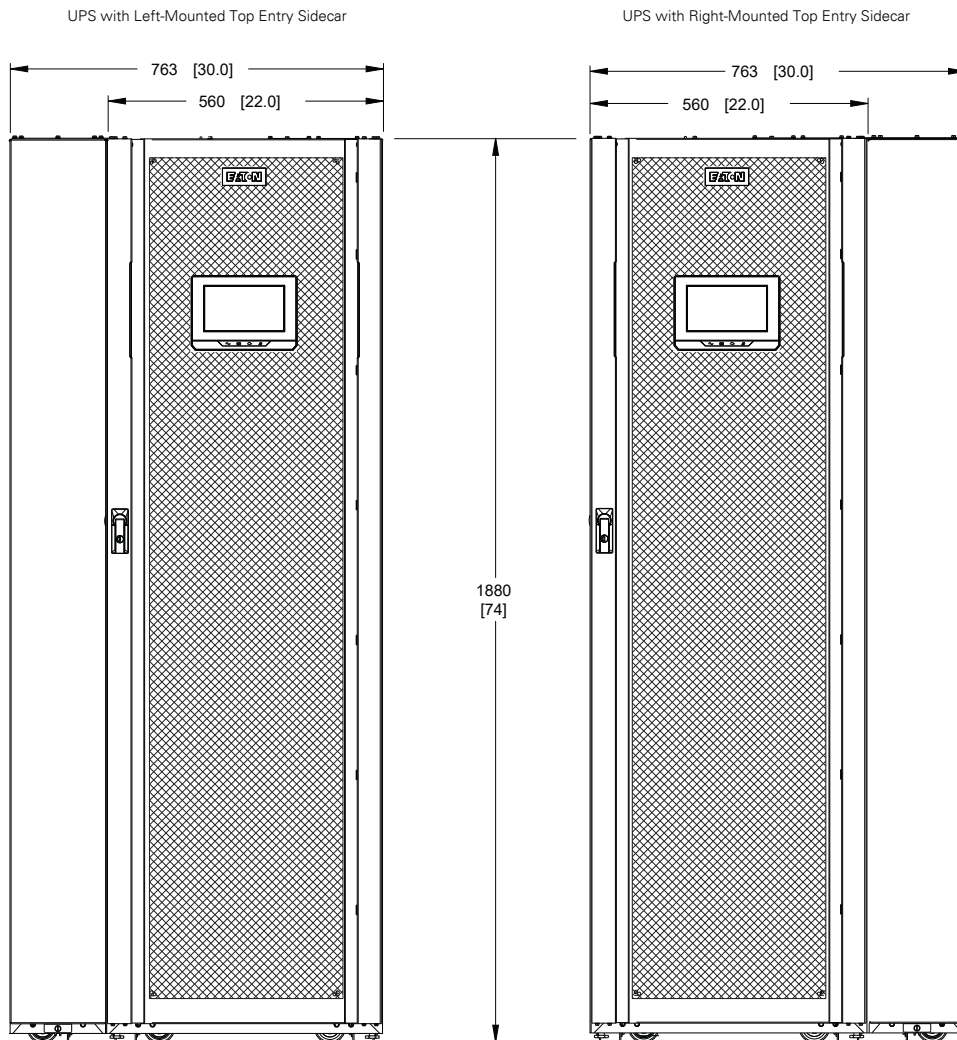

Dimensions are in millimeters (inches)

Figure 5. 93PM-L 60 kW UPS with Top Entry Sidecar Dimensions (Top and Bottom Views)

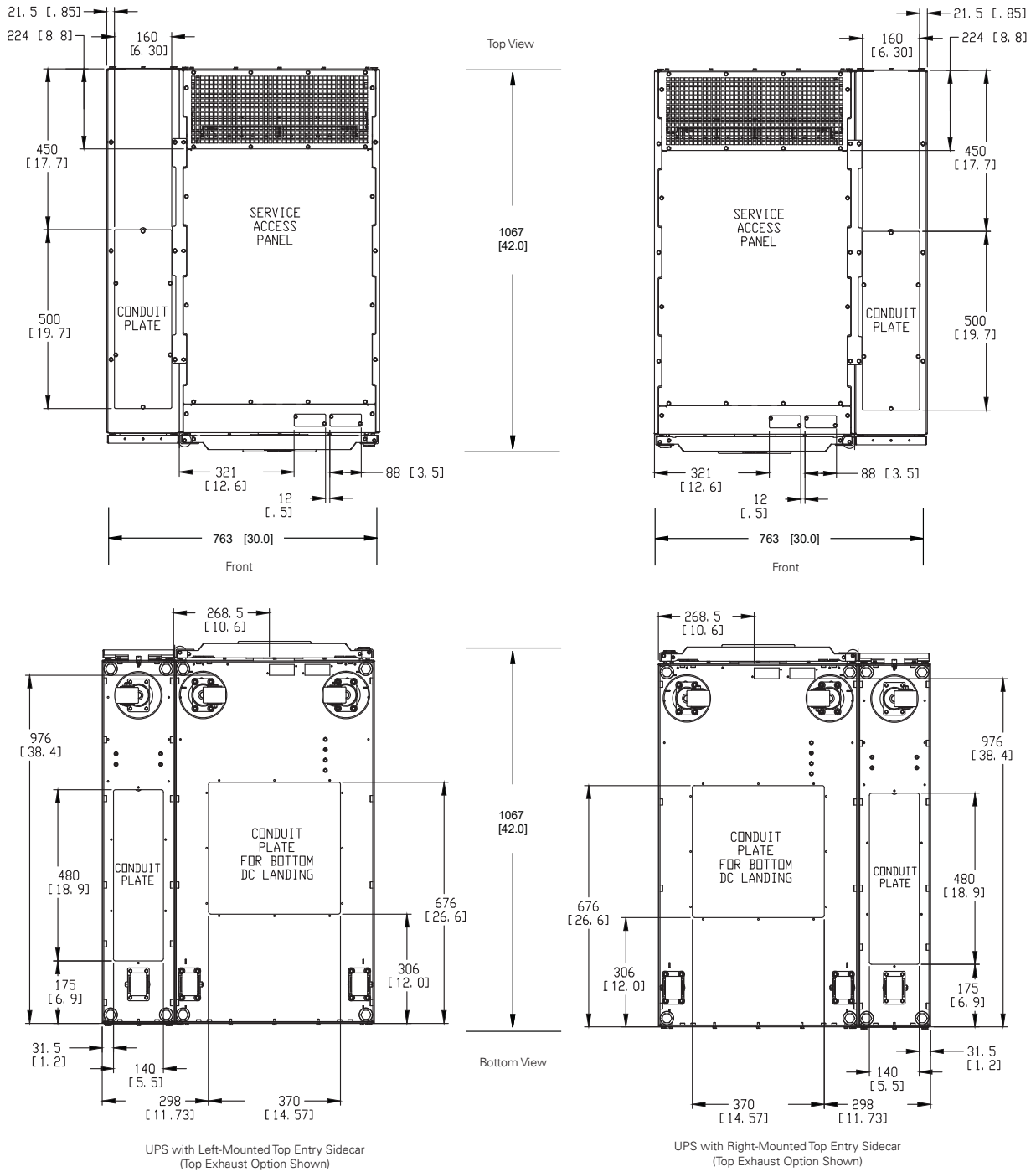

Dimensions are in millimeters [inches]

Figure 6. 93PM-L 120 kW UPS with Top Entry Wiring Sidecar Dimensions (Front View)

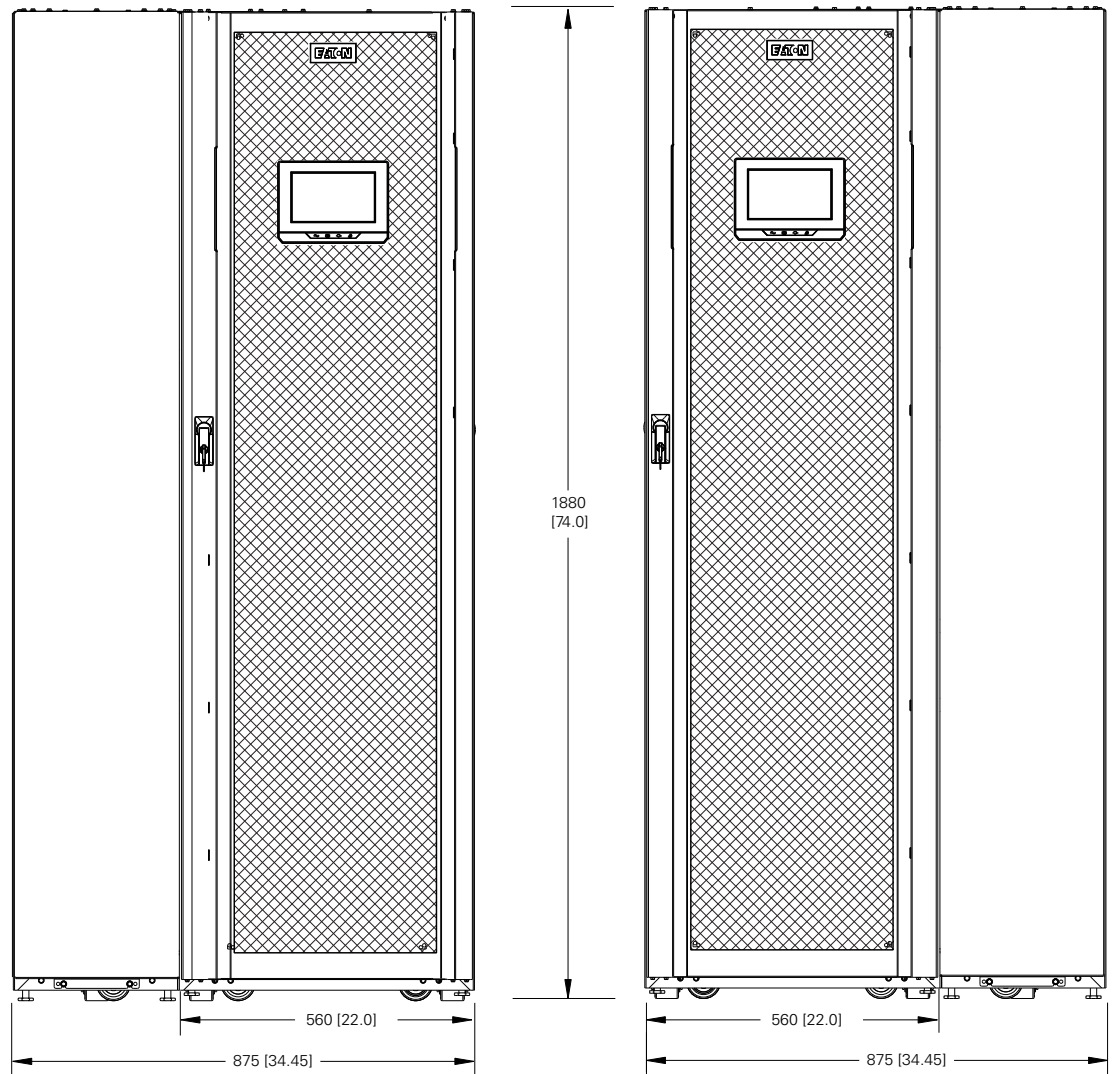

Dimensions are in millimeters [inches]

Figure 7. 93PM-L 60 kW and 120 kW UPS with SIAC-B Dimensions (Front View)

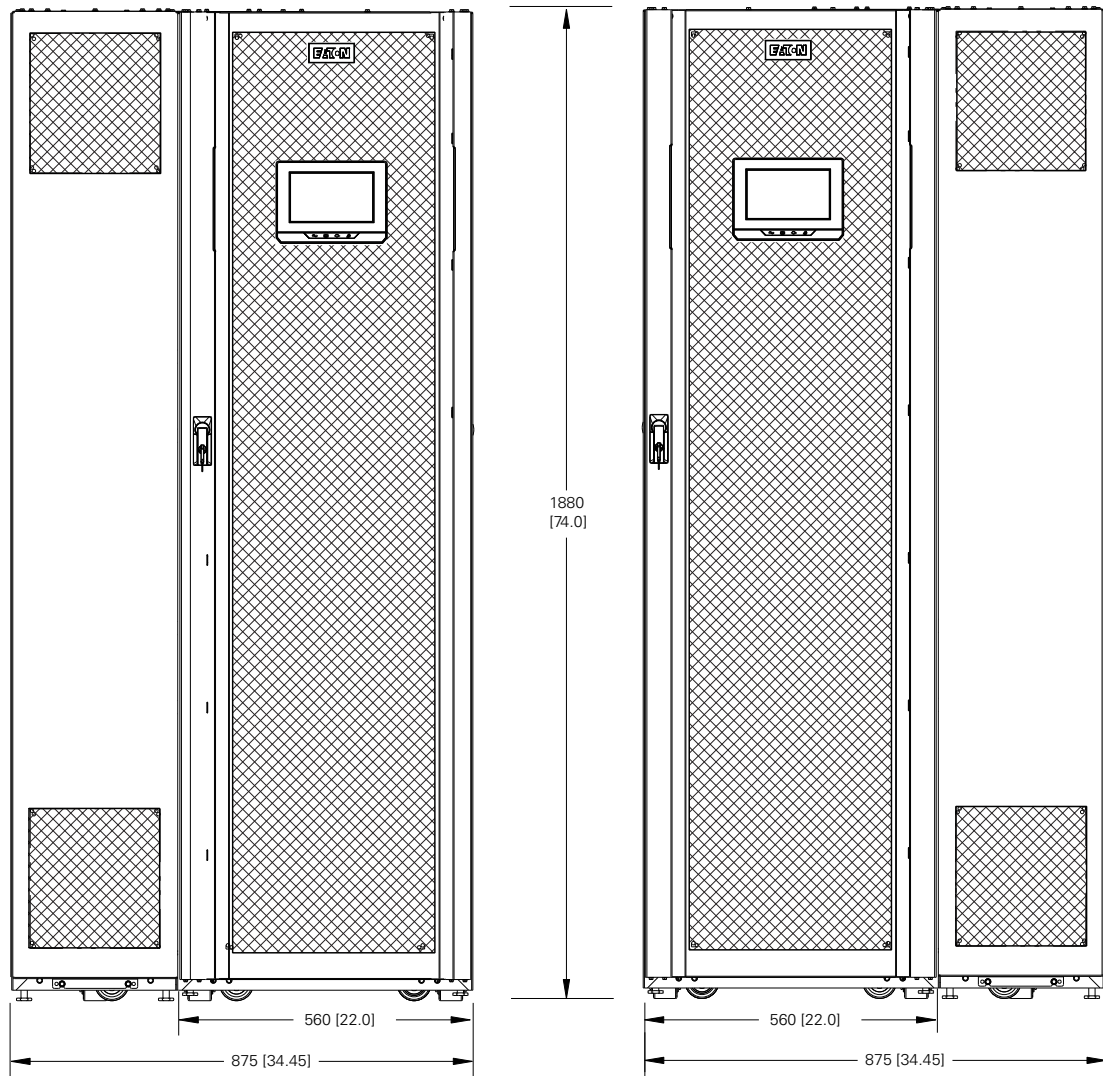

Dimensions are in millimeters [inches]

Figure 8. 93PM-L 60 and 120 kW UPS with SIAC-B Dimensions (Top and Bottom Views)

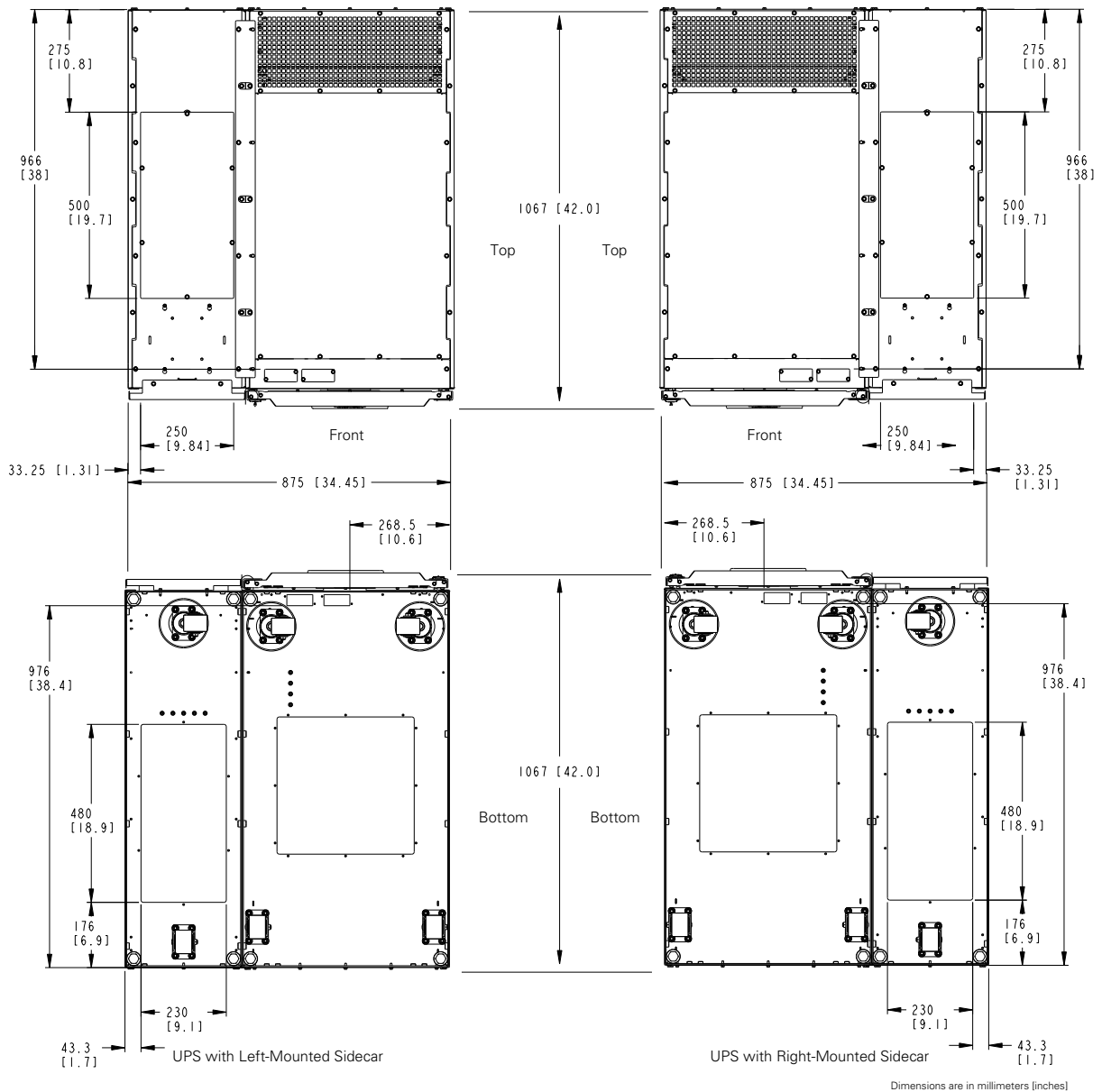

NOTE: Dimensions are the same for the 120 kW Top Entry Wiring Sidecar.

3.3.2 Floor Mounting Brackets

Floor mounting brackets are optionally available to secure the UPS with SIAC-B to the facility floor. [Figure 9](#) and [Figure 10](#) show the mounting hole locations for the brackets.

Figure 9. 93PM-L 60 and 120 kW UPS with SIAC Floor Mounting Bracket Mounting Dimensions (Rear View)

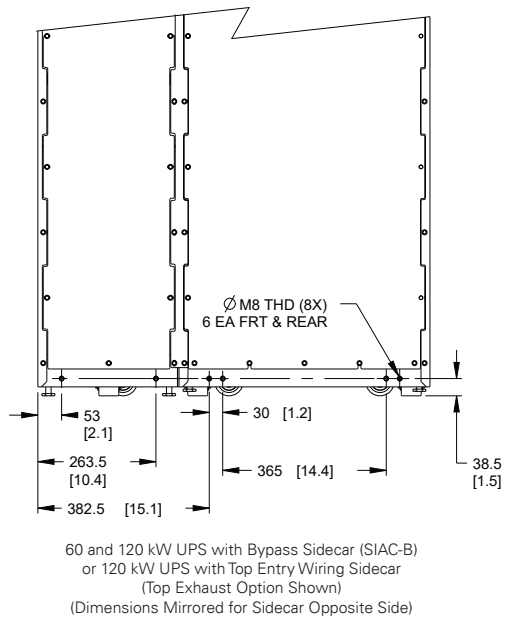
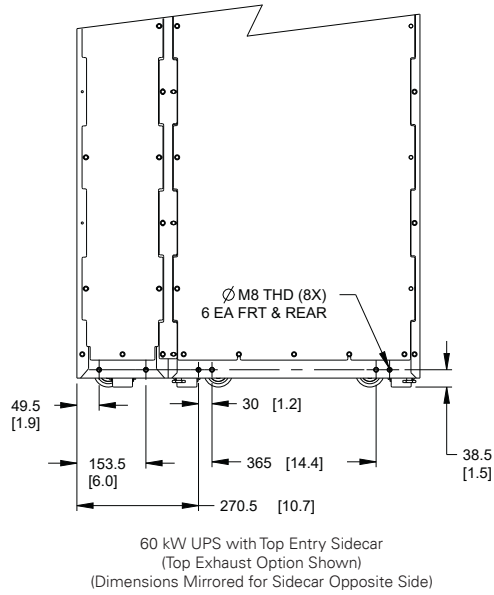

Dimensions are in millimeters [inches]

NOTE: The Front Floor Mounting Bracket's mounting dimensions are identical to the Rear Floor Mounting Bracket dimensions.

Figure 10. 93PM-L 60 and 120 kW UPS with SIAC Floor Mounting Bracket Mounting Dimensions (Top View)

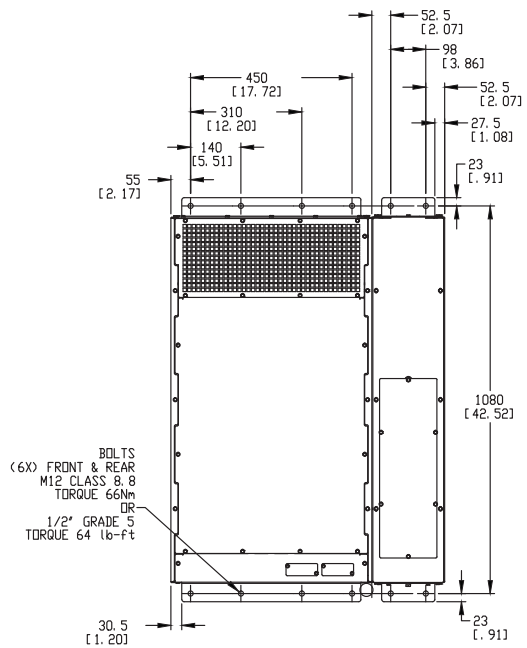

60 kW UPS with Top Entry Sidecar
(Top Exhaust Option Shown)
(Dimensions Mirrored for Sidecar Opposite Side)

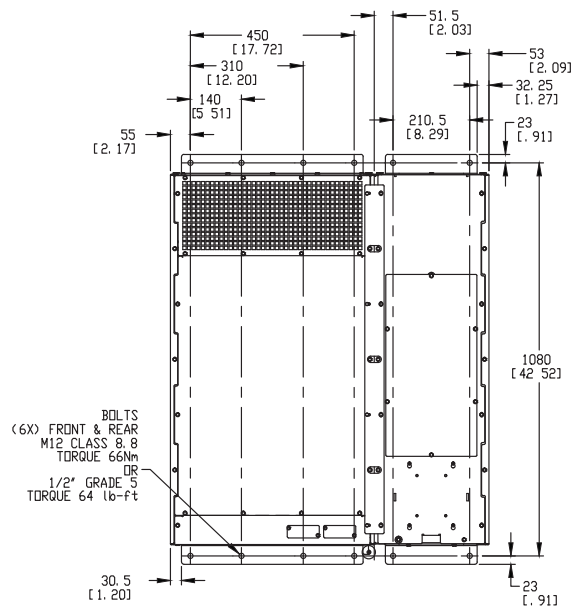

60 and 120 kW UPS with Bypass Sidecar (SIAC-B)
or 120 kW UPS with Top Entry Wiring Sidecar
(Top Exhaust Option Shown)
(Dimensions Mirrored for Sidecar Opposite Side)

Dimensions are in millimeters [inches]

3.3.3 SIAC Power Wiring Preparation

Read and understand the following notes while planning and performing the installation:

 **WARNING**

As a result of the connected loads high leakage current is possible. Connection to earth ground is required for safety and proper product operation. Do not check SIAC-B operation by any action that includes removal of the earth (ground) connection with loads attached.

- Refer to national and local electrical codes for acceptable external wiring practices.
- For external wiring, use 75°C copper wire. Wire sizes listed in [Table 3](#) through [Table 7](#) are for copper wiring only. If wire is run in an ambient temperature greater than 40°C, higher temperature wire and/or larger size wire may be necessary. Wire sizes are based on using the specified breakers.
- Recommended wire sizes are based on NFPA National Electrical Code® (NEC®) 70 Table 310.15(B)(16) 75° C ampacity with 40°C ambient correction factors.
- Four-wire SIAC-B models use a neutral for bypass input and load output, but not for rectifier input.
- The neutral conductor is sized the same as the phase conductor for balanced and resistive loads. Nonlinear loads, up to the maximum of 1.5x the load current, require a larger neutral conductor and should be sized in accordance with NFPA NEC 70 Article 310.15(B)(5).
- Refer to NEC Article 250 and local codes for proper grounding practices.
- Phase rotation must be clockwise starting with phase A (rotation A, B, C).
- Per NEC Article 300-20(a), all three-phase conductors must be run in the same conduit. A ground wire must be run in the same conduit as the phase conductors.
- Conduit is to be sized to accommodate three phase conductors, one neutral conductor, and one ground conductor. If an oversized neutral conductor is to be installed, a larger conduit size is needed to accommodate the oversized neutral.
- Refer to the appropriate Eaton 93PM UPS Installation and Operation manual listed in paragraph [1.7 For More Information](#) for UPS cabinet conduit and terminal specifications and locations.
- Material and labor for external wiring recommendations are to be provided by the customer.
- If installing an external maintenance bypass, all feeds to the UPS including the Rectifier Input Breaker (RIB) (if installed) must have a service disconnect independent of the maintenance bypass power path. Most maintenance bypass solutions provide UPS input feeds derived from but isolated from the maintenance bypass power path. If the maintenance bypass solution being installed does not provide such functionality, DO NOT use a single feeder breaker to supply both the UPS and the maintenance bypass.
- The term line-up-and-match refers to accessory cabinets that are physically located adjacent to the UPS. The term standalone refers to accessory cabinets that are located separate from the UPS.

For SIAC-B external power wiring recommendations, including the minimum AWG size of external wiring, see [Table 3](#) through [Table 7](#). Wire sizes listed are for copper wiring only.

Table 3. External Power Wiring Recommendations: Eaton 93PM-L 60 kW and 120 kW SIAC-B (208/208) — Two and Three Breaker Maintenance Bypass

	Units	Rating 50/60 Hz	
Basic Unit Rating	kW	60	120
Input and Output Voltage	Volts	208/208	208/208
AC Input to Maintenance Bypass (Four Wire, Dual-Feed) Full Load Current (3) Phases, (1) Ground	Amps	213	426
Neutral Current	Amps	288	577
Minimum Conductor Size (Phase A, B, and C) Number per Phase	B AWG or kcmil (each)	500 MCM (1)	500 MCM (2)
Neutral Wire Size Number	AWG or kcmil (each)	300 MCM (2)	300 MCM (4)
Minimum Conductor Size (Ground) Number	– AWG or kcmil (each)	1/0 (1)	1/0 (2)
AC Output to Critical Load (Four Wire) Full Load Current (3) Phases, (1) Ground	Amps	167	333
Neutral Current	Amps	288	577
Minimum Conductor Size (Phase A, B, and C) Number per Phase	D AWG or kcmil (each)	350 MCM (1)	350 MCM (2)
Neutral Wire Size Number	AWG or kcmil (each)	300 MCM (2)	300 MCM (4)
Minimum Conductor Size (Ground) Number	– AWG or kcmil (each)	2 (1)	2 (2)
Building and Inter-Cabinet Ground Minimum Conductor Size (Ground) Number	– AWG or kcmil (each)	2 (1)	2 (2)
NOTE Callout letters B and D map to Figure 23 and Figure 25 . Eaton recommends installing the UPS using wiring and external overcurrent protection breakers sized for the fully rated UPS kW frame size installed.			

Table 4. External Power Wiring Recommendations: Eaton 93PM-L 60 kW and 120 kW SIAC-B (220/220) — Two and Three Breaker Maintenance Bypass

Basic Unit Rating	Units	Rating 50/60 Hz	
	kW	60	120
Input and Output Voltage	Volts	220/220	220/220
AC Input to Maintenance Bypass (Four Wire, Dual-Feed) Full Load Current: (3) Phases, (1) Ground	Amps	202	403
Neutral Current	Amps	273	545
Minimum Conductor Size (Phase A, B, and C) Number per Phase	B AWG or kcmil (each)	500 MCM (1)	500 MCM (2)
Neutral Wire Size Number	AWG or kcmil (each)	300 MCM (2)	300 MCM (4)
Minimum Conductor Size (Ground) Number	— AWG or kcmil (each)	1/0 (1)	1/0 (2)
AC Output to Critical Load (Four Wire) Full Load Current (3) Phases, (1) Ground	Amps	157	315
Neutral Current	Amps	273	545
Minimum Conductor Size (Phase A, B, and C) Number per Phase	D AWG or kcmil (each)	300 MCM (1)	300 MCM (2)
Neutral Wire Size Number	AWG or kcmil (each)	300 MCM (2)	300 MCM (4)
Minimum Conductor Size (Ground) Number	— AWG or kcmil (each)	2 (1)	2 (2)
Building and Inter-Cabinet Ground Minimum Conductor Size (Ground) Number	— AWG or kcmil (each)	2 (1)	2 (2)
NOTE Callout letters B and D map to Figure 23 and Figure 25 . Line-up-and-match battery wiring with a 105°C rating is factory supplied with the Eaton 93PM-L Integrated Battery Cabinet (IBC). Eaton recommends installing the UPS using wiring and external overcurrent protection breakers sized for the fully rated UPS kW frame size installed.			

Table 5. External Power Wiring Recommendations: Eaton 93PM-L 60 kW and 120 kW SIAC-B (Single Input Bypass 220/208) — Two and Three Breaker Maintenance Bypass

	Units	Rating 50/60 Hz	
Basic Unit Rating	kW	60	120
Input and Output Voltage	Volts	220/208	220/208
AC Input to Maintenance Bypass (Four Wire, Single-Feed) Full Load Current: (3) Phases, (1) Ground	Amps	202	403
Neutral Current	Amps	288	577
Minimum Conductor Size (Phase A, B, and C) Number per Phase	B AWG or kcmil (each)	500 MCM (1)	500 MCM (2)
Neutral Wire Size Number	AWG or kcmil (each)	300 MCM (2)	300 MCM (4)
Minimum Conductor Size (Ground) Number	— AWG or kcmil (each)	1/0 (1)	1/0 (2)
AC Output to Critical Load (Four Wire) Full Load Current (3) Phases, (1) Ground	Amps	167	333
Neutral Current	Amps	288	577
Minimum Conductor Size (Phase A, B, and C) Number per Phase	D AWG or kcmil (each)	350 MCM (1)	350 MCM (2)
Neutral Wire Size Number	AWG or kcmil (each)	300 MCM (2)	300 MCM (4)
Minimum Conductor Size (Ground) Number	— AWG or kcmil (each)	2 (1)	2 (2)
Building and Inter-Cabinet Ground Minimum Conductor Size (Ground) Number	— AWG or kcmil (each)	2 (1)	2 (2)

NOTE Callout letters **B** and **D** map to [Figure 23](#) and [Figure 25](#).

Line-up-and-match battery wiring with a 105°C rating is factory supplied with the Eaton 93PM-L Integrated Battery Cabinet (IBC).

Eaton recommends installing the UPS using wiring and external overcurrent protection breakers sized for the fully rated UPS kW frame size installed.

Table 6. External Power Wiring Recommendations: Eaton 93PM-L 60 kW and 120 kW SIAC-B (208/208) — Four Breaker Maintenance Bypass

Basic Unit Rating	Units	Rating 50/60 Hz	
	kW	60	120
Input and Output Voltage	Volts	208/208	208/208
AC Input to RIB (3) Phases, (1) Ground	Amps	213	426
Minimum Conductor Size (Phase A, B, and C) Number per Phase	A AWG or kcmil (each)	350 MCM (1)	350 MCM (2)
Minimum Conductor Size (Ground) Number	– AWG or kcmil (each)	2 (1)	2 (2)
AC Input to Maintenance Bypass (Four Wire, Dual-Feed) Full Load Current (3) Phases – see Note, (1) Ground	Amps	213	426
Neutral Current	Amps	288	577
Minimum Conductor Size (Phase A, B, and C) Number per Phase	B AWG or kcmil (each)	500 MCM (1)	500 MCM (2)
Neutral Wire Size Number	AWG or kcmil (each)	300 MCM (2)	300 MCM (4)
Minimum Conductor Size (Ground) Number	– AWG or kcmil (each)	1/0 (1)	1/0 (2)
AC Output to Critical Load (Four Wire) Full Load Current (3) Phases – see Note, (1) Ground	Amps	167	333
Neutral Current	Amps	288	577
Minimum Conductor Size (Phase A, B, and C) Number per Phase	D AWG or kcmil (each)	350 MCM (1)	350 MCM (2)
Neutral Wire Size Number	AWG or kcmil (each)	300 MCM (2)	300 MCM (4)
Minimum Conductor Size (Ground) Number	– AWG or kcmil (each)	2 (1)	2 (2)
Building and Inter-Cabinet Ground Minimum Conductor Size (Ground) Number	– AWG or kcmil (each)	2 (1)	2 (2)

NOTE Callout letters **A**, **B** and **D** map to [Figure 23](#) and [Figure 25](#).
Line-up-and-match battery wiring with a 105°C rating is factory supplied with the Eaton 93PM-L Integrated Battery Cabinet (IBC).
Eaton recommends installing the UPS using wiring and external overcurrent protection breakers sized for the fully rated UPS kW frame size installed.

Table 7. External Power Wiring Recommendations: Eaton 93PM-L 60 kW and 120 kW SIAC-B (220/220) — Four Breaker Maintenance Bypass

		Rating 50/60 Hz	
		Units	
Basic Unit Rating		kW	60 120
Input and Output Voltage		Volts	220/220 220/220
AC Input to RIB (3) Phases, (1) Ground		Amps	202 403
Minimum Conductor Size (Phase A, B, and C) Number per Phase	A	AWG or kcmil (each)	350 MCM (1) 350 MCM (2)
Minimum Conductor Size (Ground) Number	—	AWG or kcmil (each)	2 (1) 2 (2)
AC Input to Maintenance Bypass (Four Wire, Dual-Feed) Full Load Current (3) Phases – see Note, (1) Ground		Amps	202 403
Neutral Current		Amps	273 545
Minimum Conductor Size (Phase A, B, and C) Number per Phase	B	AWG or kcmil (each)	500 MCM (1) 500 MCM (2)
Neutral Wire Size Number		AWG or kcmil (each)	300 MCM (2) 300 MCM (4)
Minimum Conductor Size (Ground) Number	—	AWG or kcmil (each)	1/0 (1) 1/0 (2)
AC Output to Critical Load (Four Wire) Full Load Current (3) Phases – see Note, (1) Ground		Amps	157 315
Neutral Current		Amps	273 545
Minimum Conductor Size (Phase A, B, and C) Number per Phase	D	AWG or kcmil (each)	300 MCM (1) 300 MCM (2)
Neutral Wire Size Number		AWG or kcmil (each)	300 MCM (2) 300 MCM (4)
Minimum Conductor Size (Ground) Number	—	AWG or kcmil (each)	2 (1) 2 (2)
Building and Inter-Cabinet Ground Minimum Conductor Size (Ground) Number	—	AWG or kcmil (each)	2 (1) 2 (2)
NOTE Callout letters A , B and D map to Figure 23 and Figure 25 . Line-up-and-match battery wiring with a 105°C rating is factory supplied with the Eaton 93PM-L Integrated Battery Cabinet (IBC). Eaton recommends installing the UPS using wiring and external overcurrent protection breakers sized for the fully rated UPS kW frame size installed.			

Table 8. External Input Power Cable Terminations for the 93PM-L 60 kW and 120 kW SIAC-B

Terminal Function	Terminal	Function	Bus Landings (using back-to-back lugs)	Tightening Torque Nm (lb in)	Screw Size and Type	
AC Input to RIB — Source 1 (4-breaker Dual-Feed version only)	E1 (RIB-1)	Phase A	60 kW UPS (See Note)	2 – 2/0 to 250 or	31 (275)	5/16" Hex
			120 kW UPS	1 – 2/0 to 500	42 (375)	3/8" Hex
	E2 (RIB-3)	Phase B	60 kW UPS (See Note)	2 – 2/0 to 250 or	31 (275)	5/16" Hex
			120 kW UPS	1 – 2/0 to 500	42 (375)	3/8" Hex
	E3 (RIB-5)	Phase C	60 kW UPS (See Note)	2 – 2/0 to 250 or	31 (275)	5/16" Hex
			120 kW UPS	1 – 2/0 to 500	42 (375)	3/8" Hex
AC Input to Maintenance Bypass — Source 2	E6	Phase A	4 – 2 bolt mounting	35 (310)	M12 Hex	
	E7	Phase B	4 – 2 bolt mounting	35 (310)	M12 Hex	
	E8	Phase C	4 – 2 bolt mounting	35 (310)	M12 Hex	
	E12	Neutral	8 – 2 bolt mounting	35 (310)	M12 Hex	
AC Output to Critical Load	E9	Phase A	4 – 2 bolt mounting	35 (310)	M12 Hex	
	E10	Phase B	4 – 2 bolt mounting	35 (310)	M12 Hex	
	E11	Phase C	4 – 2 bolt mounting	35 (310)	M12 Hex	
	E12	Neutral	8 – 2 bolt mounting	35 (310)	M12 Hex	
Building, Inter-Cabinet, and Load Ground	Ground	Ground	14 - #14-1/0 pressure termination	5.1 (45)	Slotted	

NOTE The RIB breaker has 2 holes (or bores) to accept the input wiring; each with a set screw to secure the wiring. The 60 kW RIB breaker has a small bore with a 5/16" set screw which can accept wiring from 2/0 to 250 MCM. The larger bore with a 3/8" set screw can accept wiring from 2/0 to 500 MCM. The 120 kW RIB breaker has two same sized bores with 5/16" set screws.

The power wiring terminals for the Eaton 93PM-L 60 kW and 120 kW SIAC-B are pressure terminations. The power wiring connections for this equipment are UL and CSA rated. See [Table 8](#) for external power cable terminations.

[Figure 14](#) shows the locations of the SIAC-B power cable terminals.

3.3.4 SIAC-B Interface Wiring Preparation

Control wiring for features and options should be connected at the customer interface terminal block located inside the SIAC-B.

 **WARNING**

Do not directly connect relay contacts to the mains related circuits. Reinforced insulation to the mains is required.

Read and understand the following notes while planning and performing the installation:

- Use Class 1 wiring methods (as defined by the NEC) for interface wiring from 30V to 600V. The wire should be rated for 600V, 1A minimum. 12 AWG maximum wire size.
- Use Class 2 wiring methods (as defined by the NEC) for interface wiring up to 30V. The wire should be rated for 24V, 1A minimum.
- Use twisted-pair wires for each input and return or common.
- All interface wiring and conduit is to be supplied by the customer.
- Interface wiring can be installed using the inter-cabinet wiring access pass-through or by routing wiring through conduit between cabinets.
- Install the interface wiring in separate conduit from the power wiring.

3.4 Inspecting and Unpacking the SIAC

Under normal circumstances the SIAC is attached to the UPS cabinet at the factory, but it may be ordered and shipped separately. The integrated cabinets are shipped bolted to a metal and wood pallet (see [Figure 11](#)) with outer protective packaging material covering the cabinet. Refer to the applicable Eaton 93PM UPS Installation and Operation manual listed in paragraph [1.7 For More Information](#), for inspection and unpacking instructions.

 **NOTE** Startup and operational checks must be performed by an authorized Eaton Customer Service Engineer, or the warranty terms specified in paragraph [9.1 Warranty](#) become void. This service is offered as part of the sales contract for the UPS. Contact an Eaton service representative in advance (a minimum two-week notice is required) to reserve a preferred startup date.

 **WARNING**

If unpacking and unloading instructions are not closely followed, the cabinet may tip and cause serious injury or death.

1. Carefully inspect the outer packaging for evidence of damage during transit.
-

 **NOTE** For the following step, verify that the forklift or pallet jack is rated to handle the weight of the cabinet (see [Table 1](#) or [Table 2](#)).

2. Use a forklift or pallet jack to move the packaged cabinet to the installation site, or as close as possible, before unpacking. If possible, move the cabinet using the pallet. Insert the forklift or pallet jack forks between the supports on the bottom of the pallet.
-

 **CAUTION**

Do not tilt the cabinet more than 10° from vertical or the cabinet may tip over.

3. Set the pallet on a firm, level surface, allowing a minimum clearance of 3m (10 ft) on each side for removing the cabinet from the pallet.
4. Remove the protective packaging material from the cabinet and recycle in a responsible manner. Retain any parts kits packaged with the cabinet.
5. Inspect the contents for any evidence of physical damage, and compare each item with the Bill of Lading. If damage has occurred or shortages are evident, contact an Eaton service representative immediately to determine the extent of the damage and its impact on further installation.

**NOTE**

While waiting for installation, protect the unpacked cabinet from moisture, dust, and other harmful contaminants. Failure to store and protect the UPS properly may void the warranty.

Figure 11. Eaton 93PM-L 60 kW or 120 kW Sidecar as Shipped on Pallet



93PM-L 60 kW or 120 kW SIAC-B
in Left-Mount Configuration

Chapter 4 Installation

4.1 Preliminary Installation Information



WARNING

Installation should be performed only by qualified personnel.

Refer to the following while installing the UPS system:

- Review **Chapter 3 Installation Plan and Unpacking** for cabinet dimensions, equipment weight, wiring and terminal data, and installation notes.
- Do not tilt the cabinets more than $\pm 10^\circ$ during installation.
- Remove conduit landing plates to add conduit landing holes as required.
- If perforated floor tiles are required for ventilation, place them in front of the UPS.

4.2 Unloading the Field Installed SIAC from the Pallet

The SIAC is bolted to a pallet consisting of four metal angle supports secured to two wood supports and four vertical braces.



WARNING

- The SIAC is heavy.
- Do not tilt cabinet more than 10° from vertical.
- Lift the cabinets only with a forklift or damage may occur.
- Ensure the forklift is rated to handle the weight of the cabinet.

Failure to follow these instructions may result in severe injury or death.

To remove the pallet:

1. If not already accomplished, use a forklift or pallet jack to move the SIAC to the installation area, or as close as possible, before unloading from the pallet. Insert the forklift or pallet jack forks between the supports on the bottom of the pallet.
2. Remove the screw securing the bottom of the SIAC front panel. Lift the panel straight up to remove it from the panel hanger bracket at the top of the cabinet. Retain screw for later use.
3. Locate the four 1/2" jacking bolts from the parts kit and install them in the threaded holes in the front and rear supports as shown in [Figure 12](#). Place a floor protector from the parts kit underneath each jacking bolt, and screw the bolts down against them.

The floor protectors protect the floor from being marred by the jacking bolts.

Figure 12. Removing the Pallet Skids and Supports – Eaton 93PM-L Field Installed SIAC

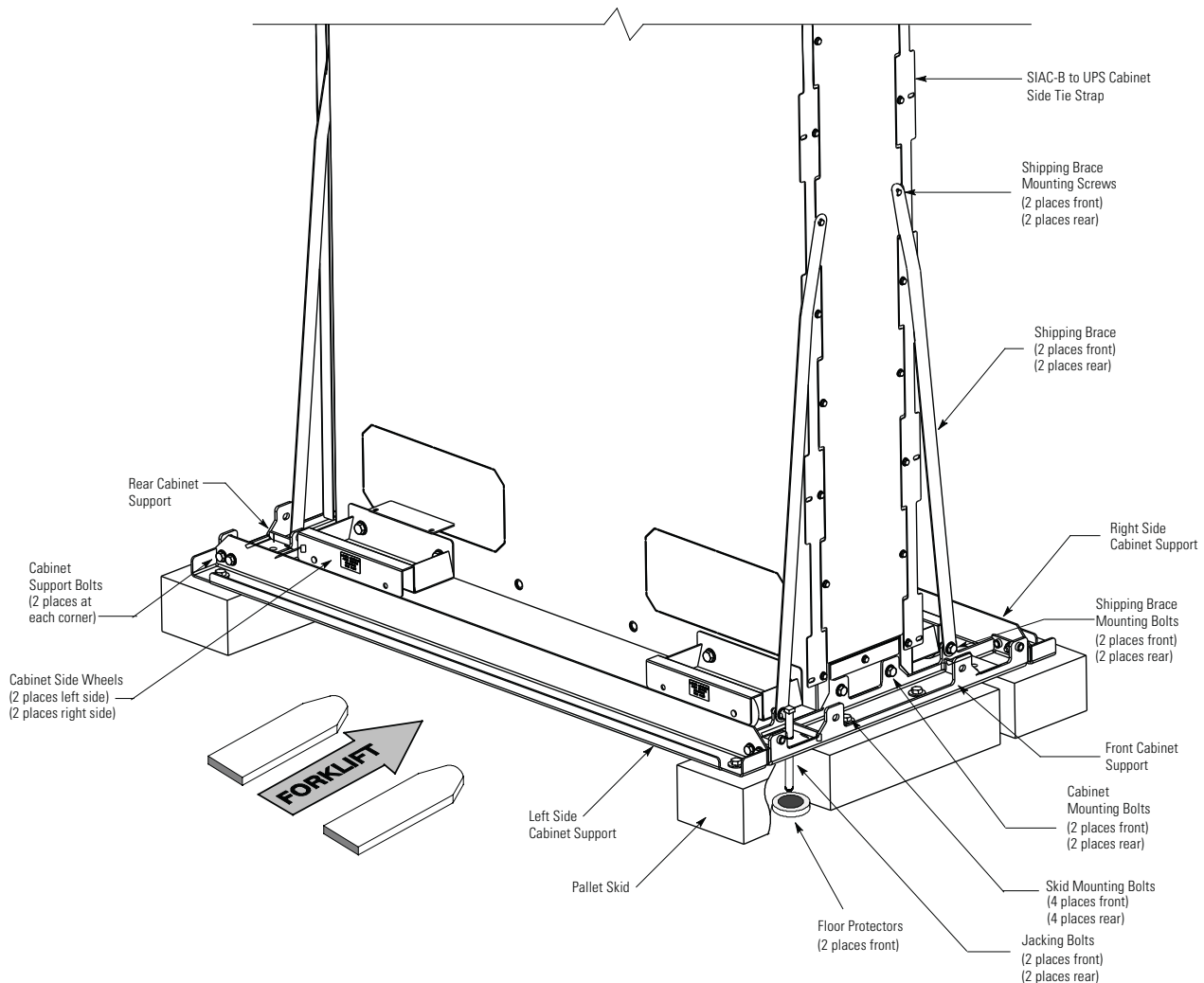

⚠ WARNING

Do not remove or loosen the cabinet mounting or cabinet support bolts until instructed. If unpacking and unloading instructions are not closely followed, the cabinet may tip and cause serious injury or death.

4. Loosen, but do not remove, the skid mounting bolts holding the pallet skids to the front and rear supports, and to the left and right side supports.

⚠ WARNING

RISK OF INSTABILITY. Turning the jacking bolts unevenly may cause the cabinet to become unbalanced. To prevent tipping the cabinet, raise the cabinet no more than 3 mm (1/8") above the floor (just enough to allow the removal of the pallet skids). Failure to follow these instructions can result in serious injury or death.

5. Turn each jacking bolt consecutively, two full turns, until the pallet skids clear the floor by approximately 3 mm (1/8").
6. Remove the hardware loosened in **Step 4**.
7. Pull the pallet skids out from under the metal angle supports without disturbing the jacking bolts. Recycle the pallet skids and hardware in a responsible manner.

**CAUTION**

CABINET MAY FALL. Do not loosen the hardware attaching the front supports to the cabinet base. The cabinet must be lowered by the jacking bolts before the supports can be removed.

8. Carefully and evenly **lower the cabinet by turning each jacking bolt consecutively two full turns (maximum)** until the cabinet side wheels contact the floor and the cabinet is no longer supported by the jacking bolts.
9. After the SIAC is resting on the floor, remove the jacking bolts and floor protectors. Recycle them in a responsible manner.
10. Remove the shipping brace screws securing the front left and right shipping braces to the cabinet. Do not reinstall screws. Recycle the screws in a responsible manner.
11. Remove the bolts securing the front left and right shipping braces to the front cabinet support. Remove the braces.
12. Remove the screws securing the back left and right shipping braces to the cabinet. Reinstall the screws (without the nylon washers) to secure the rear panel to the frame.
13. Remove the bolts securing the back left and right shipping braces to the rear cabinet support. Remove the braces.
14. Remove the cabinet support bolts fastening the front, rear, and side cabinet supports together and remove the side supports.
15. Remove the cabinet mounting bolts holding the front and rear supports to the cabinet base.
16. Recycle the bolts along with the shipping braces and support brackets in a responsible manner.
17. Reinstall the SIAC front panel and secure with retained screw.
18. If the leveling feet are not retracted, turn all four leveling feet until they are retracted as far into the cabinet as possible.

**CAUTION**

To prevent tipping when rolling the cabinet and damage to the front door, push the cabinet from the rear whenever possible. Do not push the cabinet from the sides.

19. Roll the cabinet close to the final installation location.
20. Proceed to paragraph [4.3 Mechanically Joining the UPS Cabinet and SIAC](#).

4.3 Mechanically Joining the UPS Cabinet and SIAC

To join the cabinets:

1. Lower all four leveling feet until nearly in contact with the floor.
2. Remove the two SIAC side wheels facing the UPS cabinet by removing the single bolt securing the wheel to the cabinet.
3. Move the SIAC into position against the UPS cabinet and remove the remaining two SIAC side wheels.

Mechanically Joining the UPS Cabinet and SIAC

4. Use the leveling feet to align and level the SIAC vertically with the UPS cabinet.
5. Locate the top tie strap shipped attached to the SIAC (see [Figure 13](#)) and remove the screws securing the strap to the SIAC. Retain the hardware for later use.
6. Remove the screws securing the adjacent cabinet top panel. Retain the hardware for later use.
7. Install the top tie strap between the cabinets and secure the tie strap with the retained hardware.

**NOTE**

A rear tie strap is attached to the back of the cabinet and is used only for seismic installations.

8. Locate the front tie strap shipped attached to the SIAC (see [Figure 12](#)) and remove the screws securing the strap to the SIAC. Retain the hardware for later use.
9. Remove the screws securing the adjacent cabinet front panel. Retain the hardware for later use.
10. Install the front tie strap between the cabinets and secure the tie strap with the retained hardware.
11. Remove the screws securing the internal safety shield panel and remove the panel to gain access to the pass-through tie strap. Retain the hardware for later use.
12. Locate the pass-through tie strap at the bottom right or left side of the SIAC (see [Figure 13](#)) and remove the screws securing the strap to the SIAC.
13. Remove the corresponding screws at the bottom of the UPS cabinet pass-through. Retain the hardware for later use.
14. Install the pass-through tie strap between the cabinets and secure the tie strap with the retained hardware.
15. If necessary after the installing the attaching straps, secure the SIAC in position by adjusting the leveling feet until the cabinet is level and locked in place.
16. Proceed to paragraph [4.4 Electrically Connecting the UPS Cabinet and SIAC-B](#).

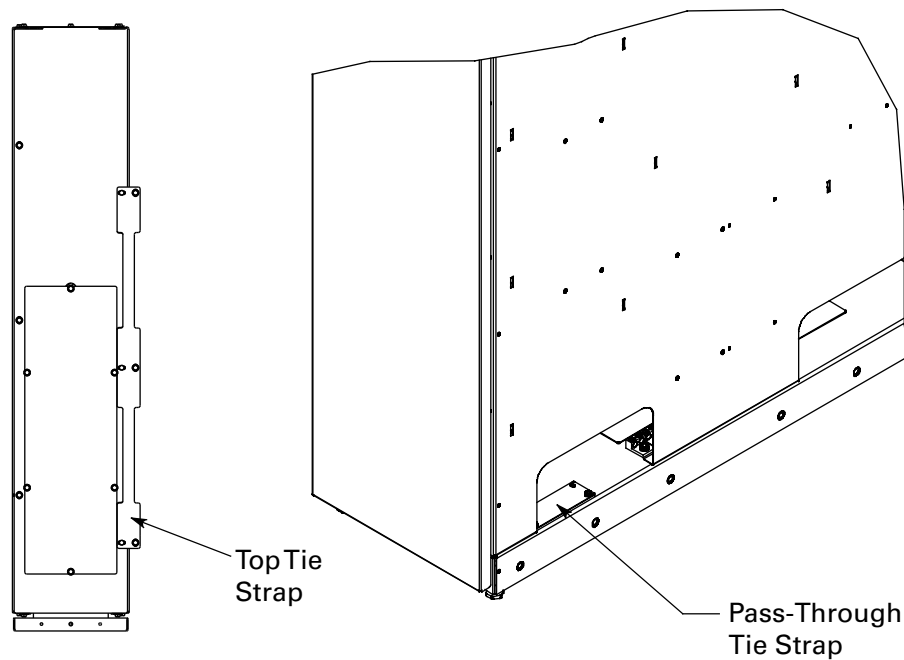
Figure 13. SIAC to Cabinet Tie Strap Locations

4.4 Electrically Connecting the UPS Cabinet and SIAC-B

Use the following procedures to wire the SIAC-B to the UPS cabinet.

4.4.1 Installing SIAC-B Internal Power Wiring

To install wiring:



NOTE

The number of power wiring phase harnesses provided will depend on the SIAC-B's breaker configuration. A two breaker SIAC-B (MBP and MIS) will have a single power wiring phase harness. A three breaker SIAC-B (MBP, MIS and BIB) will have two power wiring phase harnesses. A four breaker SIAC-B (MBP, MIS, BIB and RIB) will have three power wiring phase harnesses.

1. Locate and remove the power wiring phase harnesses, neutral harnesses, and MBP interface harness packed inside the SIAC-B. Retain for later use.



NOTE

When routing cable harnesses, ensure the cables ends marked UPS are routed to the UPS terminals.

2. Route the phase harness ends marked for the UPS Output, UPS Bypass, and UPS Input (if installed) from the SIAC-B through the bottom of the SIAC-B and UPS inter-cabinet wiring access pass-through to the UPS cabinet terminals. See [Figure 14](#) for SIAC-B terminal locations. Refer to the applicable Eaton 93PM UPS Installation and Operation manual, listed in paragraph [1.7 For More Information](#), for the UPS pass-through, terminal locations and termination requirements.
3. In the UPS cabinet, locate the harness cable ends marked UPS Output. Connect marked phase A, B, and C cable ends to the corresponding output terminals of the UPS.

4. In the UPS cabinet, locate the harness cable ends marked UPS Bypass. Connect marked phase A, B, and C cable ends to the corresponding bypass input terminals of the UPS.
5. In the UPS cabinet if an RIB is installed, locate the harness cable ends marked UPS Input. Connect marked phase A, B, and C cable ends to the corresponding rectifier input terminals of the UPS.
6. In the SIAC-B, locate the harness cable ends marked MIS. Connect marked phase A, B, and C terminal number cable ends to the corresponding terminal number of the MIS breaker.
For a detailed view of the MIS breaker terminals, see [Figure 15](#). Tighten terminals to 31Nm (275 lb in) torque.
7. In the SIAC-B if the BIB is installed, locate the harness cable ends marked BIB. Connect marked phase A, B, and C terminal number cable ends to the corresponding terminal number of the BIB breaker.
For a detailed view of the BIB breaker terminals, see [Figure 16](#). Tighten terminals to 31Nm (275 lb in) torque.
8. In the SIAC-B if the RIB is installed, locate the harness cable ends marked RIB. Connect marked phase A, B, and C terminal number cable ends to the corresponding terminal number of the RIB breaker.
For a detailed view of the RIB breaker terminals, see [Figure 17](#). Tighten terminals to 31Nm (275 lb in) torque.

**NOTE**

When routing neutral cable harnesses, ensure the cable ends with the Gray and Red Anderson connectors are routed to the SIAC-B neutral connectors.

9. Route the output and bypass neutral harnesses from the SIAC-B through the bottom of the SIAC-B and UPS inter-cabinet wiring access pass-through to the UPS cabinet terminals. See [Figure 14](#) for SIAC-B terminal locations. Refer to the applicable Eaton 93PM UPS Installation and Operation manual, listed in paragraph [1.7 For More Information](#), for the UPS pass-through and terminal locations.
10. In the UPS cabinet, locate the harness cable ends marked UPS E12 Output. Connect marked cable ends to the corresponding neutral terminals of the UPS.
11. In the UPS cabinet, locate the harness cable ends marked UPS E12 Bypass. Connect marked cable ends to the corresponding neutral terminals of the UPS.
12. In the SIAC-B, locate the cable with the Gray Anderson connector and connect to the Gray Anderson connector mounted to the cabinet sidewall.
13. In the SIAC-B, locate the cable with the Red Anderson connector and connect to the Red Anderson connector mounted to the cabinet sidewall.
14. Proceed to paragraph [4.7 Two-Hole Barrel Lug Terminations to Bus Bar Installation](#).

Figure 14. Eaton 93PM-L 60 kW and 120 kW SIAC-B Left or Right-Mounted Bypass Terminal Locations

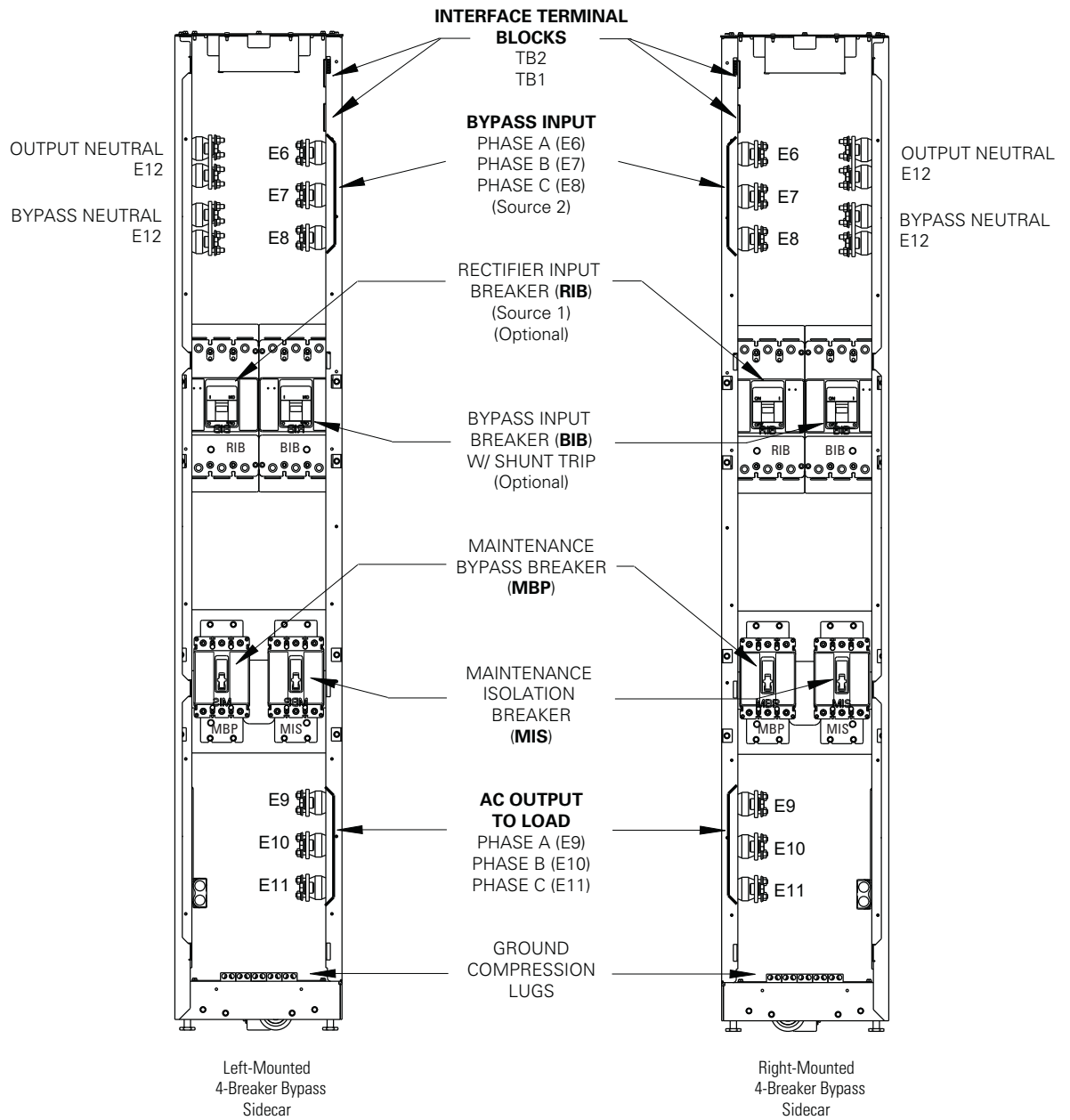

Figure 15. Maintenance Isolation Breaker (MIS) Terminal Detail

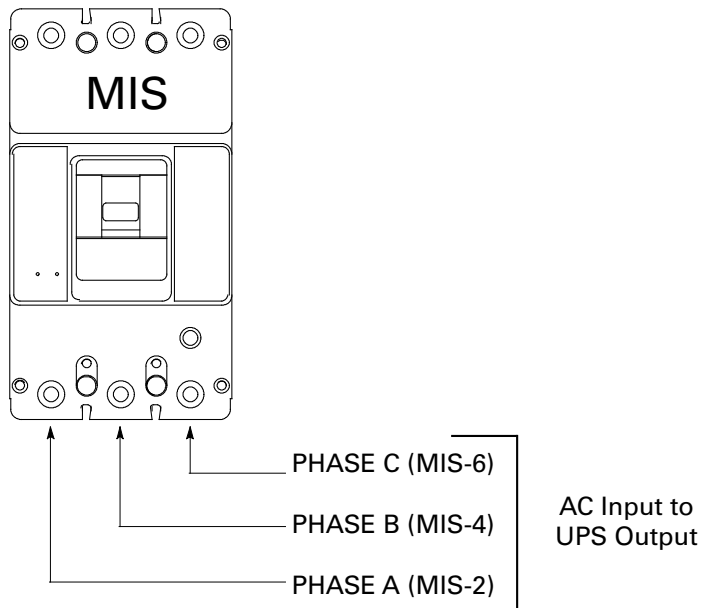

Figure 16. Bypass Input Breaker (BIB) Terminal Detail

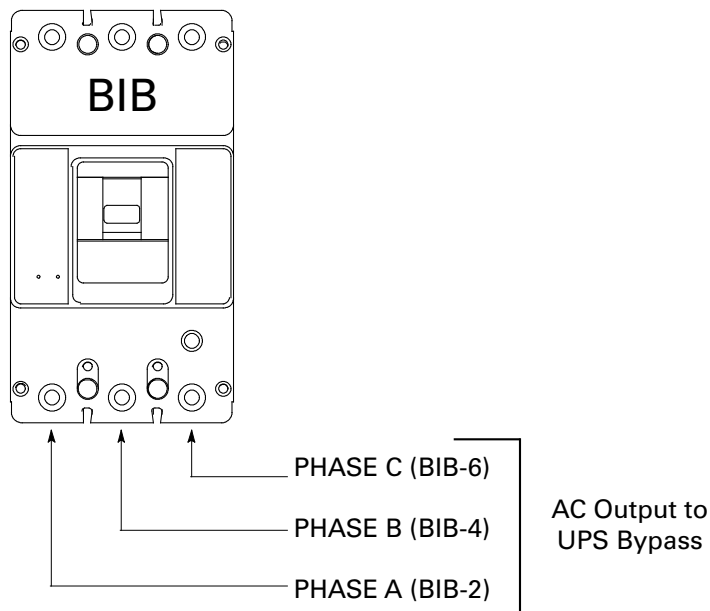
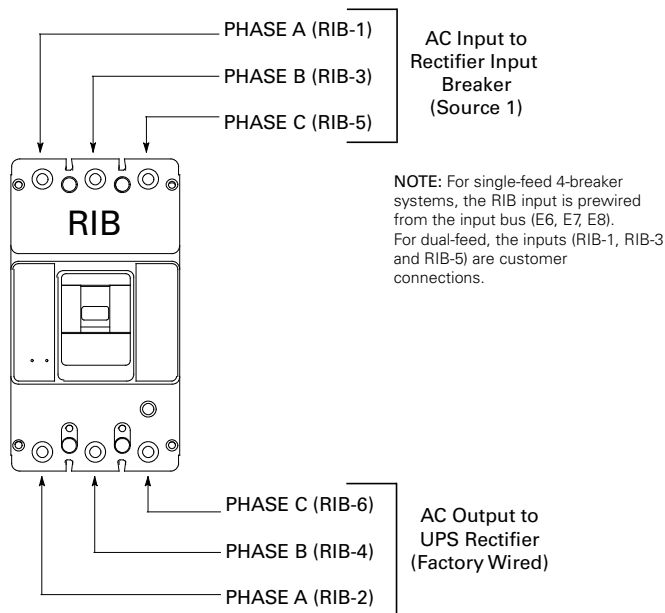

Figure 17. Rectifier Input Breaker (RIB) Terminal Detail



4.5 Removing and Reinstalling the Factory Installed SIAC-B



NOTE

The following procedure is to be used in the event that the UPS and factory installed SIAC-B are too wide to fit through doorways at the installation site.

4.5.1 Electrically Disconnecting the UPS Cabinet and SIAC-B

To disconnect wiring:

1. Verify the UPS system is turned off and all power sources are removed. Refer to the applicable Eaton 93PM UPS Installation and Operation manual, listed in paragraph [1.7 For More Information](#), for UPS operating instructions.
2. To gain access to the UPS input and output wiring area, refer to the applicable Eaton 93PM UPS Installation and Operation manual, listed in paragraph [1.7 For More Information](#).
3. Locate the UPS output, the UPS bypass input, and if an RIB is installed the UPS rectifier input. Tag and disconnect all phase and neutral wiring.
4. Locate the UPS MBP interface harness and connector and disconnect at the UPS connector (see [Figure 14](#), and [Figure 20](#)).
5. Proceed to [4.5.2 Mechanically Disconnecting the UPS Cabinet and SIAC-B](#).

4.5.2 Mechanically Disconnecting the UPS Cabinet and SIAC-B

To disconnect the cabinets:

1. Remove the hardware securing the bottom of the SIAC-B front panel. Lift the panel straight up to remove it from the panel hanger bracket at the top of the cabinet. Retain hardware for later use.

Removing and Reinstalling the Factory Installed SIAC-B

2. Remove the screws securing the internal safety shield panel and remove the panel. Retain the hardware for later use.
3. Lower the leveling feet until in contact with the floor.
4. Carefully pull all disconnected cables through the pass-through into the bottom of the SIAC-B.
5. Remove the screws securing the top tie strap and remove the strap (see [Figure 13](#)). Retain the strap and hardware for later use.
6. Remove the screws securing the pass-through tie strap and remove the strap (see [Figure 13](#)). Retain the strap and hardware for later use.



NOTE

The rear shipping bracket attached to the back of the cabinet is used only for shipping and seismic installations. Recycle the bracket in a responsible manner unless needed for seismic installation.

7. Remove the screws securing the rear shipping bracket and remove the bracket (refer to the applicable Eaton 93PM UPS Installation and Operation manual, listed in paragraph [1.7 For More Information](#), for strap location). Reinstall the screws.



CAUTION

Brace the SIAC-B after removing from the UPS cabinet to prevent the SIAC-B from falling,

8. Carefully slide the SIAC-B away from the UPS cabinet.
9. Move the cabinets to the installation area.
10. Proceed to paragraph [4.5.3 Mechanically Rejoining the UPS Cabinet and SIAC-B](#).

4.5.3 Mechanically Rejoining the UPS Cabinet and SIAC-B

To rejoin the cabinets:

1. Move the SIAC-B into position against the UPS cabinet.
2. Use the leveling feet to align and level the SIAC-B vertically with the UPS cabinet.
3. Reinstall the top tie strap (see [Figure 13](#)) removed in paragraph [4.5.2 Mechanically Disconnecting the UPS Cabinet and SIAC-B](#) and secure the tie strap with the retained hardware.



NOTE

A rear tie strap is attached to the back of the cabinet and is used only for seismic installations.

4. Reinstall the pass-through tie strap (see [Figure 13](#)) between the cabinets and secure the tie strap with the retained hardware.
5. If necessary after the installing the attaching straps, secure the SIAC-B in position by adjusting the leveling feet until the cabinet is level and locked in place.
6. Proceed to paragraph [4.5.4 Electrically Reconnecting the UPS Cabinet and SIAC-B](#).

4.5.4 Electrically Reconnecting the UPS Cabinet and SIAC-B

To reinstall wiring:

1. Carefully route all disconnected cables through the pass-through into the bottom of the UPS cabinet.
2. Reconnect the UPS output, the UPS bypass input, and if an RIB is installed the UPS rectifier input tagged wiring to the respective UPS terminals. Refer to the applicable Eaton 93PM UPS Installation and Operation manual, listed in paragraph [1.7 For More Information](#), for terminal locations and requirements.

3. Reconnect the tagged neutral wiring to the respective UPS terminals. Refer to the applicable Eaton 93PM UPS Installation and Operation manual, listed in paragraph [1.7 For More Information](#), for terminal locations and requirements.
4. Reconnect the UPS MBP interface harness connector to the UPS MBP interface terminal block connector (see [Figure 14](#), and [Figure 20](#)).
5. Refer to the applicable Eaton 93PM UPS Installation and Operation manual, listed in paragraph [1.7 For More Information](#), to complete the mechanical installation of the UPS and SIAC-B. After completing the mechanical installation return to paragraph [4.7 Two-Hole Barrel Lug Terminations to Bus Bar Installation](#).

4.6 Unloading the Factory Installed SIAC-B from the Pallet and Mechanical Installation

The SIAC-B is attached to and directly integrated with the UPS cabinet at the factory. Refer to the applicable Eaton 93PM UPS Installation and Operation manual listed in paragraph [1.7 For More Information](#) for unloading and mechanical installation instructions.

After completing the unloading and installation of the UPS with the attached SIAC-B, proceed to paragraph [4.8 Installing SIAC-B External Power Wiring](#).

4.7 Two-Hole Barrel Lug Terminations to Bus Bar Installation

Paragraphs and detail processes that require connecting input and output wiring using 2-hole barrel lugs. See [Figure 18](#) for the hardware sequence when installing the lugs to the bus bars. Tighten the bolt to the torque value listed in **Chapter 3 Installation Plan and Unpacking**, External Input Power Cable Terminations Table.

NOTE Conical washers are special purpose washers that look similar to flat washers, except for a slight conical shape. When installing conical washers, the top of the dome should be next to the bolt head and the base of the washer should be against the flat washer.

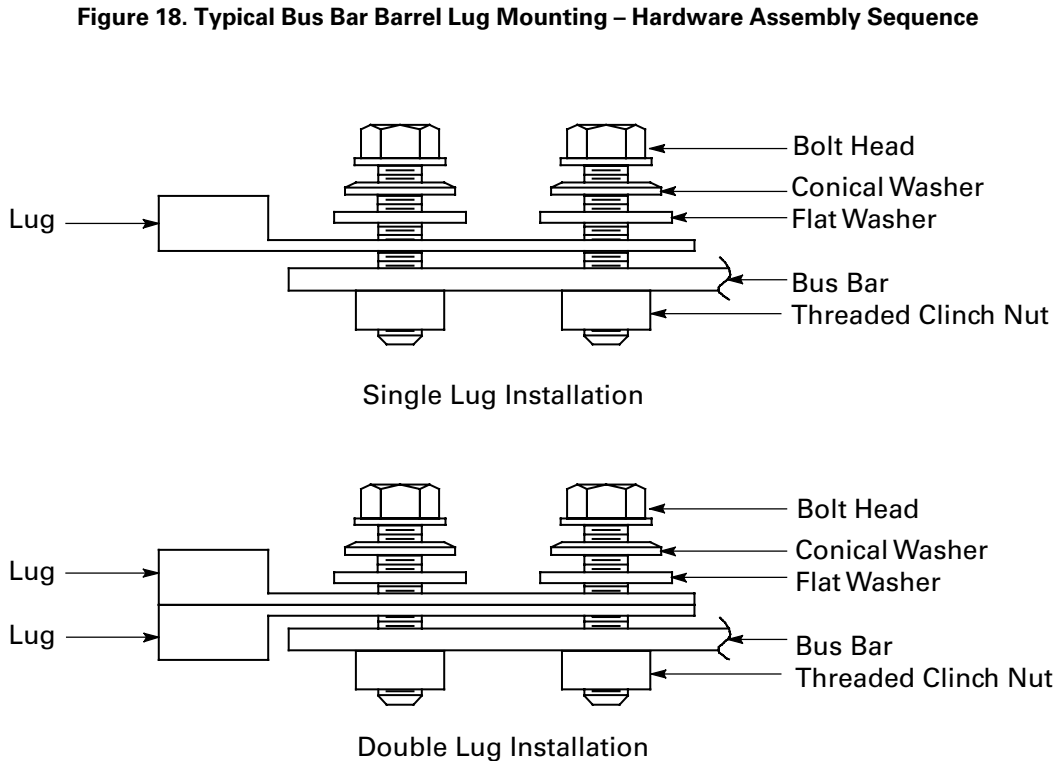

4.8 Installing SIAC-B External Power Wiring

NOTE 1 The SIAC-B Bypass Input Breaker (BIB) to UPS bypass input, the output from UPS, and the Rectifier Input Breaker (RIB) to UPS rectifier input (if installed) phase and ground wiring are prewired to the SIAC-B.

NOTE 2 External power wiring can be routed either through the top or bottom of the SIAC-B.

NOTE 3 Remove the SIAC-B top or bottom conduit landing plate to drill or punch conduit holes (see [Figure 19](#)).

To install wiring:

1. Remove the screw securing the bottom of the SIAC-B front panel. Lift the panel straight up to remove it from the panel hanger bracket at the top of the cabinet. Retain screw for later use.

2. Remove the screws securing the internal safety shield panel and remove the panel to gain access to the maintenance bypass input, critical load output, and rectifier input (if installed) terminals. Retain the hardware for later use.
3. If wiring the SIAC-B using top entry wiring access, proceed to **Step 4**; otherwise, proceed to **Step 7**.
4. **Top Entry Wiring.** Remove the top conduit landing plate (see [Figure 19](#)) from the top of the SIAC-B. Identify all conduit requirements and mark their location. Drill and punch all conduit holes in the top cover prior to mounting on the SIAC-B. Install the top conduit plate and install all conduit runs into the top cover.
5. Route the maintenance bypass input, critical load output, and rectifier input (if installed) cables (phase A, B, and C, Ground, and if required Neutral) through the conduit on the top of the SIAC-B to the SIAC-B terminals. See [Figure 14](#) for terminal locations.
6. Proceed to **Step 9**.
7. **Bottom Entry Wiring.** Remove the bottom conduit landing plate from the bottom of the SIAC-B. Identify all conduit requirements and mark their location. Drill and punch all conduit holes in the bottom conduit plate prior to mounting on the SIAC-B. Install the conduit plate and install all conduit runs into the plate.
8. Route the maintenance bypass input, critical load output, and rectifier input (if installed) cables (phase A, B, and C, Ground, and if required Neutral) through the conduit on the bottom of the SIAC-B to the SIAC-B terminals.
9. Connect phase A, B, and C, Ground, and Neutral bypass input power wiring from the utility source to the SIAC-B maintenance bypass input terminals. See paragraph [3.3.3 SIAC Power Wiring Preparation](#), [Table 3](#), [Table 4](#), [Table 5](#), [Table 6](#), or [Table 7](#) for SIAC-B wiring and termination recommendations.
For SIAC-B terminal phase wiring assignments, see [Figure 14](#).
10. Connect phase A, B, and C, Ground, and Neutral output power wiring from the SIAC-B output terminals to the critical load or Integrated Accessory Cabinet-Distribution (IAC-D). Refer to the applicable Eaton 93PM UPS or 93PM accessory cabinet installation and operation manual listed in paragraph [1.7 For More Information](#) for conduit and terminal locations and termination requirements.
11. If an RIB is installed, connect phase A, B, and C, and Ground rectifier input power wiring from the utility source to the SIAC-B rectifier input terminals.
For a detailed view of the SIAC-B RIB terminals, see [Figure 17](#).
12. If installing SIAC-B Interface Connections, go to paragraph [4.9 Installing SIAC-B Interface Connections](#); otherwise proceed to **Step 13**.
13. Reinstall the internal safety shield panel and secure with retained screws.
14. Reinstall the SIAC-B front panel and secure with retained screw.
15. After the SIAC-B is wired, return to the applicable Eaton 93PM UPS installation and operation manual listed in paragraph [1.7 For More Information](#) to complete the UPS wiring.

Figure 19. Eaton 93PM-L 60 kW and 120 kW SIAC-B Conduit Landing Wire Entry Locations

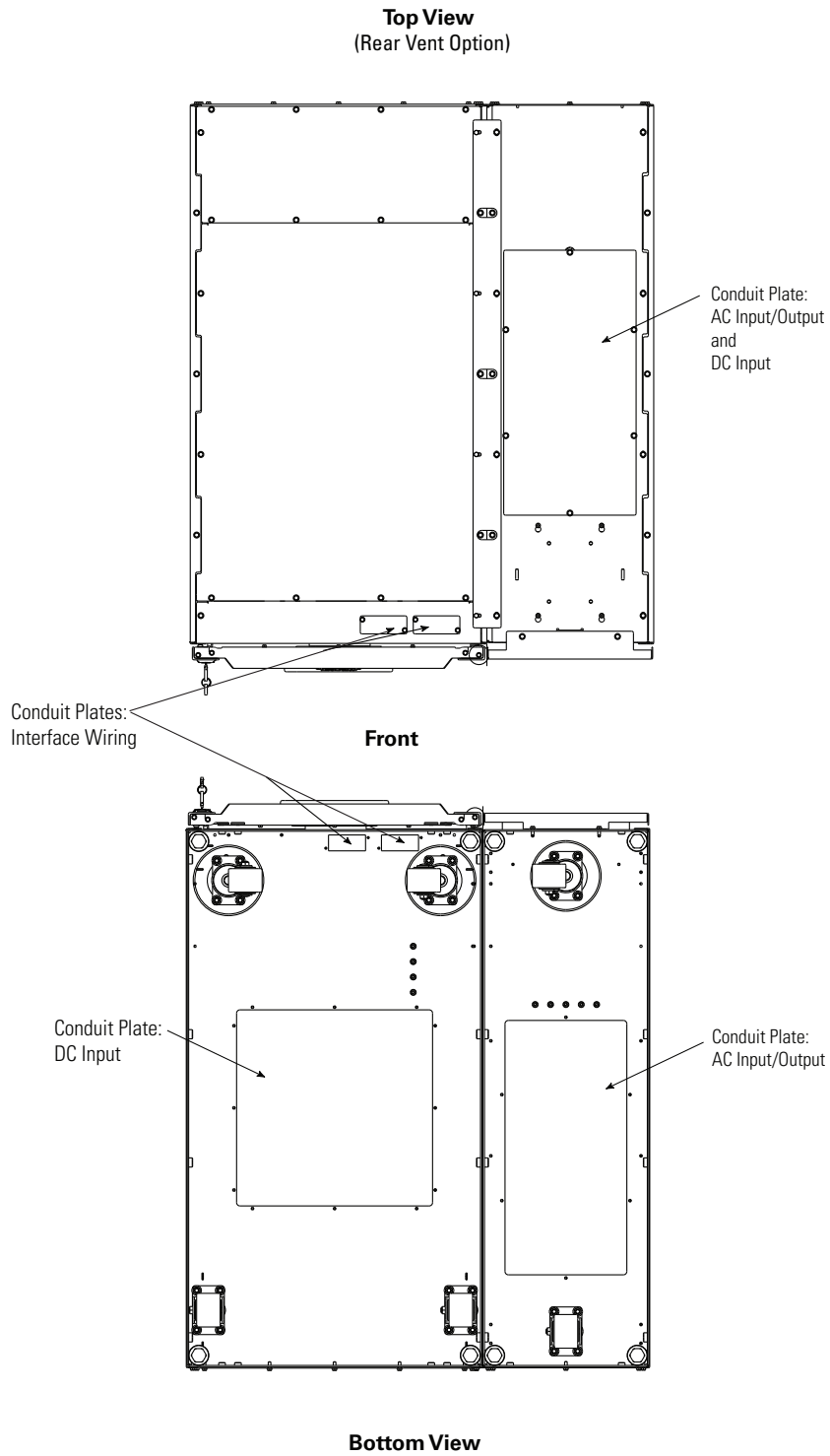

4.9 Installing SIAC-B Interface Connections

Use the procedures in the following paragraphs to connect the various interface connections.

4.9.1 Installing Sidecar Breaker Monitoring Connections

-
- NOTE 1** In a 2 Breaker Sidecar; only the Maintenance Bypass Breaker (MBP) is pre-wired for monitoring.
- NOTE 2** In a 3 or 4 Breaker Sidecar; both the Maintenance Bypass Breaker (MBP) and the Bypass Input Breaker (BIB) are pre-wired for monitoring.
-

To install wiring:

1. Verify the UPS system is turned off and all power sources are removed. Refer to the applicable Eaton 93PM UPS Installation and Operation manual, listed in paragraph [1.7 For More Information](#), for UPS operating instructions.
2. If not already removed, loosen the bottom screws and completely remove the top screws securing the sidecar front panel. Lift the panel upwards and remove from the unit. Retain the hardware for later use.
3. Route the wiring along the sidecar interface wiring channel to the sidecar terminals, TB1 and TB2.
4. Secure the wiring to the wire tie anchors provided using Zip ties.
5. If 2, 3 or 4 Breaker Sidecar and monitoring of the Maintenance Isolation Breaker (MIS) is required, connect the building alarm interface wiring to TB1. Refer to the applicable Eaton 93PM UPS Installation and Operation manual, listed in paragraph [1.7 For More Information](#) and [Table 9](#) for wiring and termination requirements. See [Figure 14](#), and [Figure 20](#) for terminal locations and assignments.
6. If 4 Breaker Sidecar and monitoring of the Rectifier Input Breaker (RIB) is required, connect the building alarm interface wiring to TB2.
7. Reinstall all safety shield panels previously removed and secure with the retained hardware.
8. Reinstall the sidecar front panel and secure with the retained hardware.
9. Close the UPS outside door and secure the latch.

Table 9. Sidecar MIS and RIB Breaker Monitoring Connection and Wire Terminations

Terminal Block	Terminal	Name	Recommended Minimum Wire Size	Size of Pressure Termination	Tightening Torque
TB1	9	MIS - Aux COM	Twisted Pair Wires #18 AWG	#14 #30 AWG	2 lb in (0.22-0.25 Nm)
	10	MIS - Aux NC			
TB2	9	RIB - Aux COM			
	10	RIB - Aux NC			

Figure 20. Sidecar TB1 and TB2 Terminal Locations

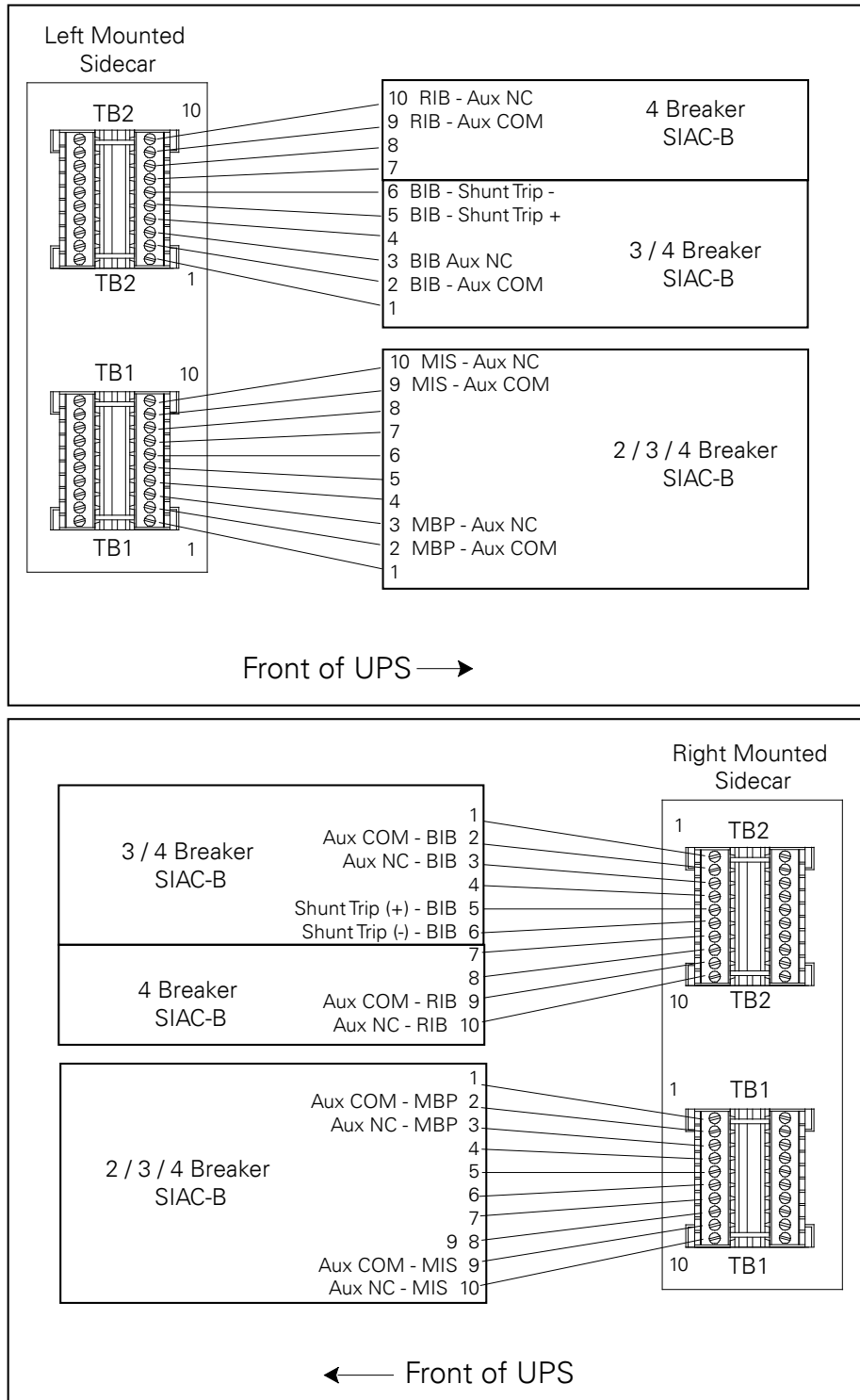

4.10 Initial Startup

Startup may be performed by the customer's battery qualified electrical contractor for single (not parallel) UPS installations without any accessory cabinets such as an External Battery Cabinet.

Startup and operational checks for parallel systems or installations with accessory cabinets must be performed by an authorized Eaton Customer Service Engineer, or the warranty terms specified in paragraph [9.1 Warranty](#) become void. This service is offered as part of the sales contract for the UPS. Contact an Eaton service representative in advance (usually a two-week notice is required) to reserve a preferred startup date.

4.11 Completing the Installation Checklist

The final step in installing the UPS system is completing the following Installation Checklist. This checklist ensures that you have completely installed all hardware, cables, and other equipment. Complete all items listed on the checklist to ensure a smooth installation. Make a copy of the Installation Checklist before filling it out, and retain the original.

After the installation is complete, an Eaton Customer Service Engineer must verify the operation of the UPS system and commission it to support the critical load. The service representative cannot perform any installation tasks other than verifying software and operating setup parameters. Service personnel may request a copy of the completed Installation Checklist to verify all applicable equipment installations have been completed.



NOTE

The Installation Checklist MUST be completed prior to starting the UPS system for the first time.

Installation Checklist

- All packing materials and restraints have been removed from each cabinet.
- The UPS cabinet is placed in its installed location.
- All conduits and cables are properly routed to the UPS and any ancillary cabinets.
- All power cables are properly sized and terminated.
- Battery cables are terminated on E4 (+) and E5 (-).
- Battery shunt trip signal wiring is connected from the UPS to the battery disconnect.
- Battery detect signal wiring is connected from the UPS to the battery disconnect.
- A ground conductor is properly installed.
- Building alarms and alarm relays are wired appropriately. (Optional)
- LAN drops are installed. (Optional)
- LAN connections have been completed. (Optional)
- The REPO device is mounted in its installed location and its wiring is terminated inside the UPS cabinet. (Optional)
- A jumper wire is connected between pins 3 and 4 on the REPO terminal block if using a normally-closed REPO switch. (Optional)
- All internal safety shields are installed.
- Accessories are mounted in installed locations and wiring is terminated inside the UPS cabinet. (Optional)
- Air conditioning equipment is installed and operating correctly.
- The area around the installed UPS system is clean and dust-free. (Eaton recommends that the UPS be installed on a level floor suitable for computer or electronic equipment.)

Completing the Installation Checklist

- Adequate workspace exists around the UPS and other cabinets.
- Adequate lighting is provided around all UPS equipment.
- A 120 Vac service outlet is located within 7.5m (25 ft) of the UPS equipment.
- Startup and operational checks are performed by an authorized Eaton Customer Service Engineer for parallel systems or installations with accessory cabinets.
- Visit www.eaton.com/pg/register to register your new Eaton UPS / Eaton UPS Accessory.

Notes

Completing the Installation Checklist

Chapter 5 Operation

5.1 SIAC-B Operating Instructions

This section describes how to operate the Sidecar Integrated Accessory Cabinet-Bypass (SIAC-B).



NOTE 1 Before using the SIAC-B, ensure all installation tasks are complete and a preliminary startup has been performed by authorized service personnel. The preliminary startup verifies all electrical interconnections to ensure the installation was successful and the system operates properly.

NOTE 2 Read this section of the manual and have thorough knowledge of UPS and SIAC-B operation before attempting to operate any of the controls.

5.1.1 Sidecar Integrated Accessory Cabinet-Bypass

5.1.1.1 Circuit Breakers

[Figure 21](#) identifies and shows the location of the circuit breakers in the SIAC-B. The following descriptions provide a brief overview of the SIAC-B breaker use.

- **Maintenance Bypass Breaker** – The Maintenance Bypass Breaker (MBP) transfers the load from the UPS output to the bypass input feeder.
- **Maintenance Isolation Breaker** – The Maintenance Isolation Breaker (MIS) isolates the UPS from the bypass feed and the load.
- **Bypass Input Breaker** – (Optional – only three and four breaker configurations) The Bypass Input Breaker (BIB) provides a single point of input power control to the UPS on single-feed systems or bypass input power control to the UPS on dual-feed systems. Using the BIB easily removes power from the UPS for servicing.
- **Rectifier Input Breaker** – (Optional – only four breaker configurations) The optional Rectifier Input Breaker (RIB) (four-breaker version only) provides a single point of rectifier input power control to the UPS on dual-feed systems and easily removes power from the UPS for servicing.

5.1.1.2 Using the UPS when an SIAC-B is Installed

To operate the SIAC-B:

1. Remove the screw securing the bottom of the SIAC-B front panel. Lift the panel straight up to remove it from the panel hanger bracket at the top of the cabinet. Retain screw for later use.
2. Close the SIAC-B bypass input feeder circuit breaker.
3. If an BIB is installed, close the SIAC-B bypass input feeder breaker.
4. If an RIB is installed, close the SIAC-B rectifier input feeder breaker.
5. Verify that the SIAC-B circuit breakers are set as follows (see [Table 10](#) and [Figure 21](#) for breaker settings and locations):

Table 10. SIAC-B Circuit Breaker Position Settings

Circuit Breaker	Position Setting
MBP	OPEN
MIS	CLOSED
BIB (if installed)	CLOSED
RIB (if installed)	CLOSED

6. Start the UPS. Refer to the applicable Eaton 93PM UPS Installation and Operation manual listed in paragraph [1.7 For More Information](#), for UPS operating procedures.
7. Reinstall the SIAC-B front panel and secure with retained screw.

Figure 21. Eaton 93PM-L SIAC-B Breaker Locations

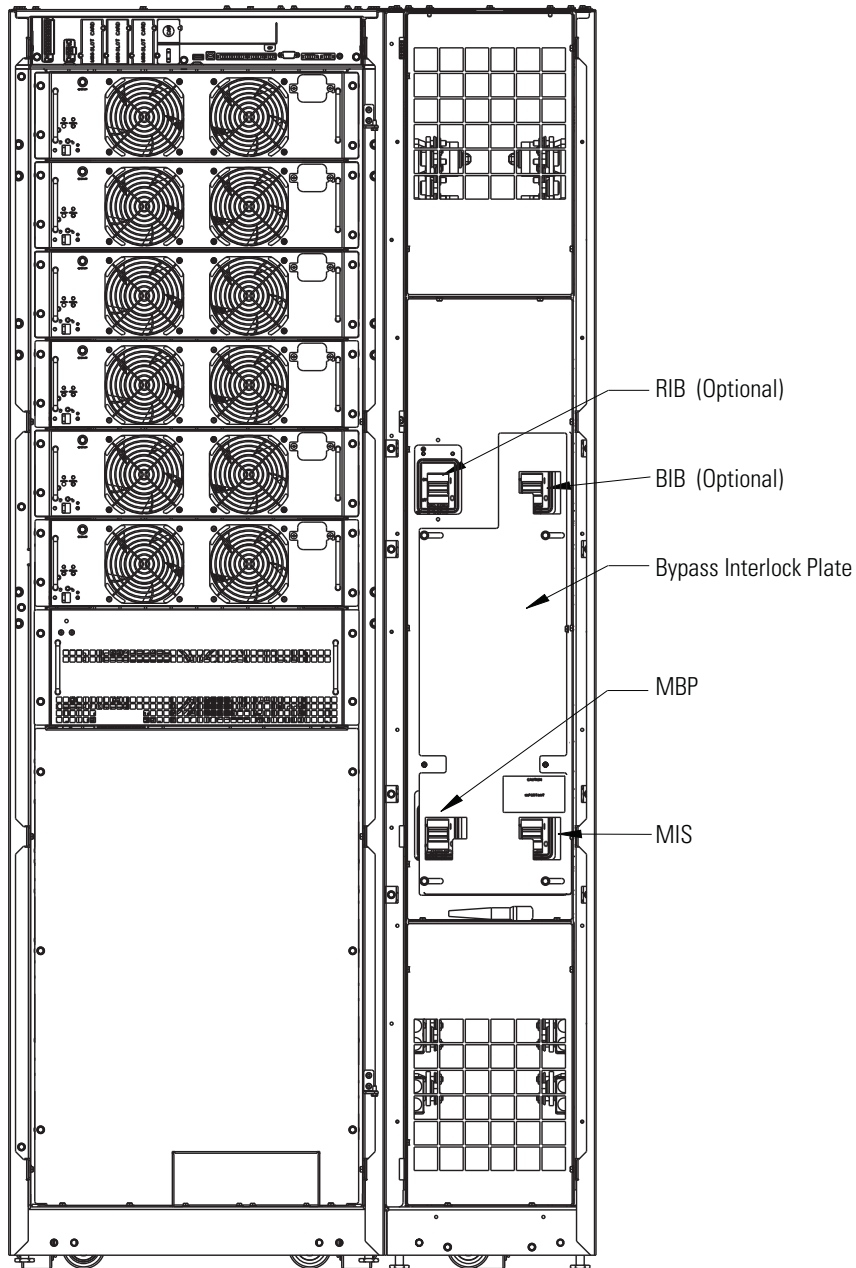

NOTE: 93PM-L 120 kW UPS with 4 breaker SIAC-B shown.

NOTE: The 93PM-L 60 kW and 120 kW SIAC-B Breaker locations are identical.

5.1.1.3 Transferring the UPS to Maintenance Bypass using an SIAC-B



CAUTION

Only trained personnel familiar with the operation of this equipment should transfer loads. Failure to follow this transfer sequence may cause loss of power to loads.



CAUTION

In Bypass mode, the critical load is not protected from commercial power interruptions and abnormalities.

To transfer the load to maintenance bypass:

1. Remove the screw securing the bottom of the SIAC-B front panel. Lift the panel straight up to remove it from the panel hanger bracket at the top of the cabinet. Retain screw for later use.
 2. Transfer the UPS from normal mode to bypass mode. Refer to the applicable Eaton 93PM UPS Installation and Operation manual listed in paragraph [1.7 For More Information](#) for UPS operating procedures.
-



CAUTION

Failure to close the MBP before opening the MIS will result in the loss of power to the critical load.

3. Close the MBP.
 4. Slide the bypass interlock plate to the left (see [Figure 21](#)).
 5. Open the MIS.
The critical load is supplied by the maintenance bypass source.
 6. Shut down the UPS. Refer to the applicable Eaton 93PM UPS Installation and Operation manual listed in paragraph [1.7 For More Information](#) for UPS operating procedures.
-



WARNING

The BIB and RIB (if installed) or the bypass feeder breaker must be opened to electrically isolate the UPS.

7. If installed, open the BIB.
8. If installed, open the RIB.
9. Reinstall the SIAC-B front panel and secure with retained screw.

5.1.1.4 Transferring the UPS from Maintenance Bypass using an SIAC-B



CAUTION

Only trained personnel familiar with the operation of this equipment should transfer loads. Failure to follow this transfer sequence may cause loss of power to loads.

To transfer the load from maintenance:

1. Remove the screw securing the bottom of the SIAC-B front panel. Lift the panel straight up to remove it from the panel hanger bracket at the top of the cabinet. Retain screw for later use.
2. If installed, close the BIB.
3. If installed, close the RIB.

4. Start the UPS in bypass mode. Refer to the applicable Eaton 93PM UPS Installation and Operation manual listed in paragraph [1.7 For More Information](#) for UPS operating procedures.



CAUTION

Failure to close the MIS before opening the MBP will result in the loss of power to the critical load.

5. Close the MIS.
6. Slide the bypass interlock plate to the right (see [Figure 21](#)).
7. Open the MBP.
8. Reinstall the SIAC-B front panel and secure with retained screw.
9. Transfer the UPS to Normal mode. Refer to the applicable Eaton 93PM UPS Installation and Operation manual listed in paragraph [1.7 For More Information](#) for UPS operating procedures.

Chapter 6 Onelines and Schematics

6.1 UPS with Sidecar Online Schematics

The system oneline drawings in this section show the simplified internal structure of the UPS, battery supply, and SIAC-B.

Figure 22. Eaton 93PM-L 60 kW UPS with Top Entry Sidecar System Online

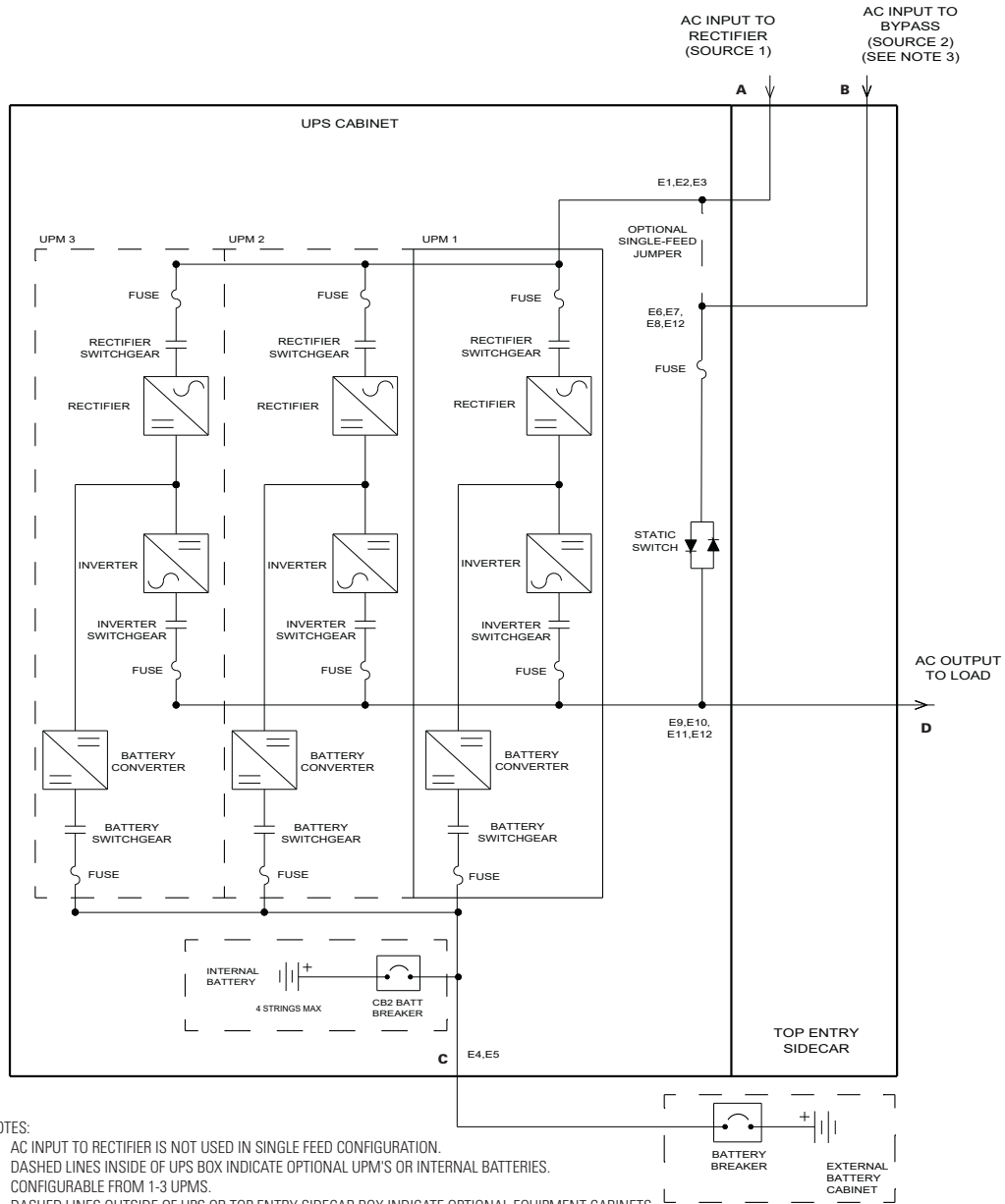

NOTES:

1. AC INPUT TO RECTIFIER IS NOT USED IN SINGLE FEED CONFIGURATION.
2. DASHED LINES INSIDE OF UPS BOX INDICATE OPTIONAL UPM'S OR INTERNAL BATTERIES. CONFIGURABLE FROM 1-3 UPM'S.
3. DASHED LINES OUTSIDE OF UPS OR TOP ENTRY SIDECAR BOX INDICATE OPTIONAL EQUIPMENT CABINETS.
4. BACKFEED PROTECTION IS NOT PROVIDED AS A PART OF UPS. CUSTOMER SUPPLIED BYPASS INPUT BREAKER WITH 48-60VDC SHUNT TRIP IS REQUIRED.

Figure 23. Eaton 93PM-L 60 kW UPS with SIAC-B (Bypass Sidecar) System Online

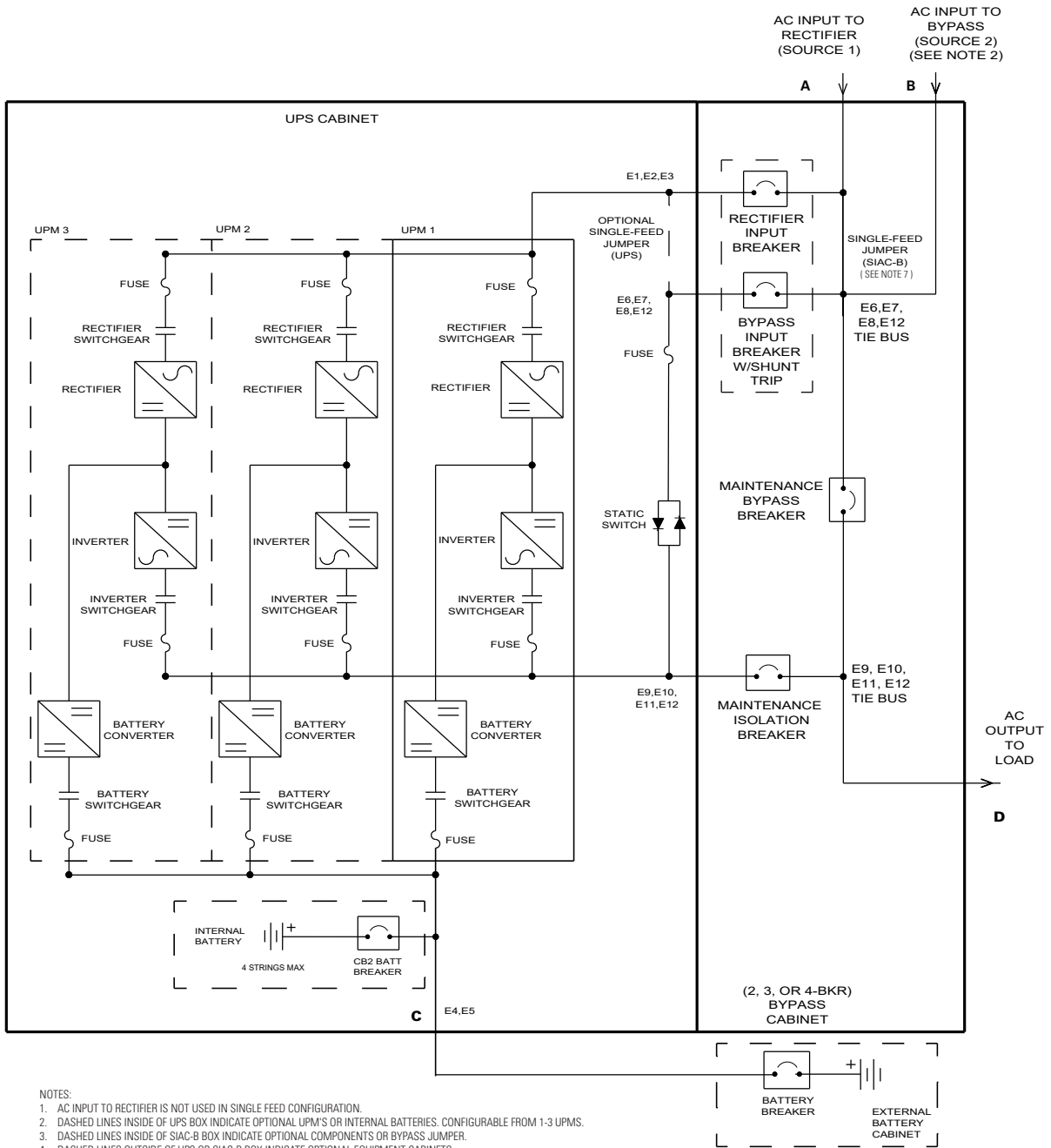

NOTES:

1. AC INPUT TO RECTIFIER IS NOT USED IN SINGLE FEED CONFIGURATION.
2. DASHED LINES INSIDE OF UPS BOX INDICATE OPTIONAL UPM'S OR INTERNAL BATTERIES. CONFIGURABLE FROM 1-3 UPM'S.
3. DASHED LINES INSIDE OF SIAC-B BOX INDICATE OPTIONAL COMPONENTS OR BYPASS JUMPER.
4. DASHED LINES OUTSIDE OF UPS OR SIAC-B BOX INDICATE OPTIONAL EQUIPMENT CABINETS.
5. BACKFEED PROTECTION IS NOT PROVIDED AS A PART OF UPS. CUSTOMER SUPPLIED BYPASS INPUT BREAKER WITH 48-60VDC SHUNT TRIP IS REQUIRED IF BYPASS SIDE CAR DOES NOT INCLUDE BIB BREAKER.
6. THE SINGLE-FEED JUMPER (UPS) IS FACTORY INSTALLED WHEN THE UPS IS ORDERED WITH A 2 OR 3 BREAKER SIDE CAR.
7. THE SINGLE FEED JUMPER (SIAC-B) IS FACTORY INSTALLED WHEN THE UPS IS ORDERED WITH A 4-BREAKER SIDE CAR. THE JUMPER MUST BE REMOVED FOR A DUAL FEED INSTALLATIONS. THE 4-BREAKER SIDE CAR IS ONLY AVAILABLE WITH A DUAL FEED UPS.

Figure 24. Eaton 93PM-L 120 kW UPS with Top Entry Sidecar System Online

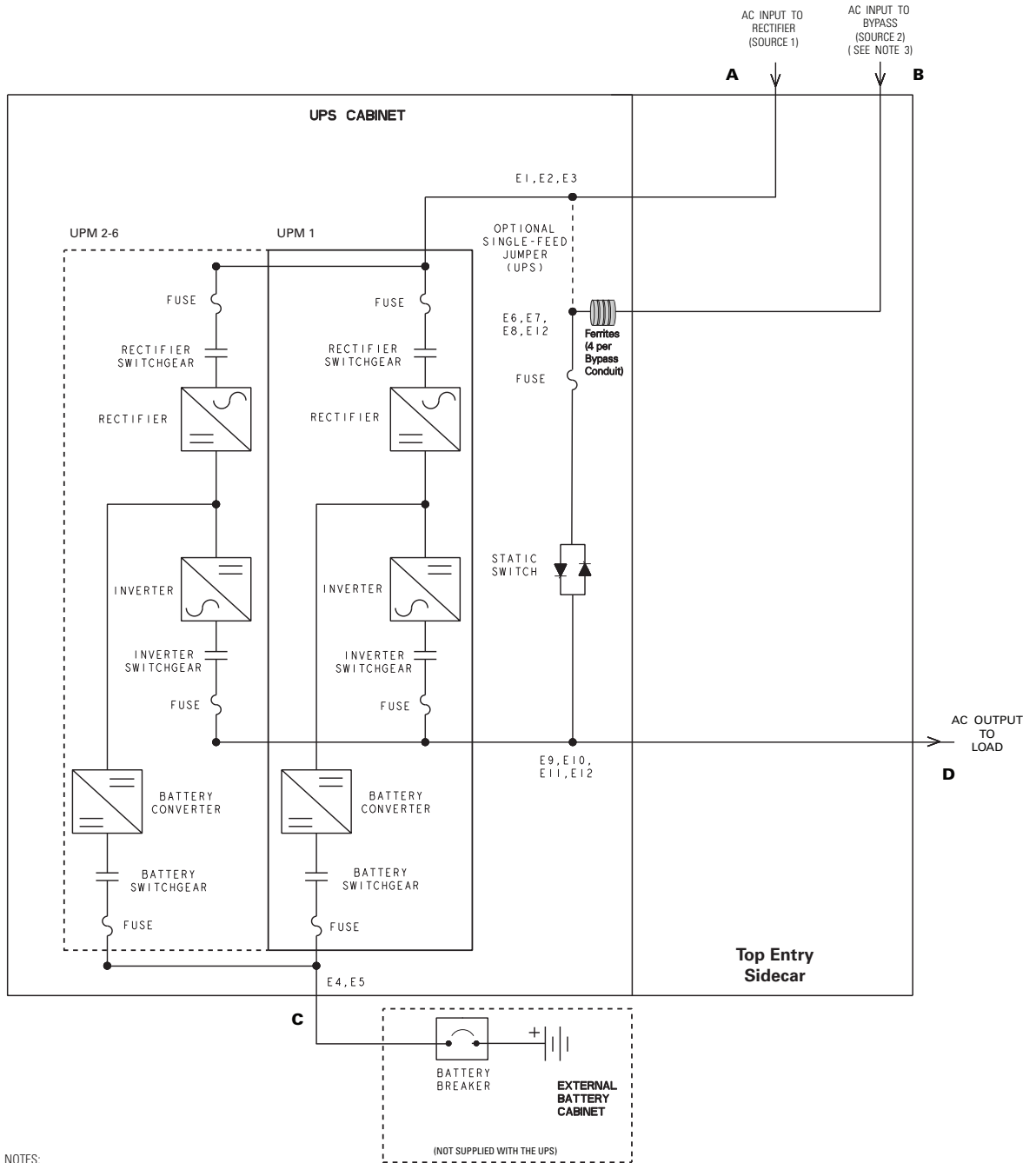

- NOTES:
1. AC INPUT TO RECTIFIER IS NOT USED IN SINGLE FEED CONFIGURATION.
 2. DASHED LINES INSIDE OF UPS BOX INDICATE OPTIONAL UPM'S OR INTERNAL BATTERIES. CONFIGURABLE FROM 1-6 UPMS.
 3. DASHED LINES OUTSIDE OF UPS OR TOP ENTRY SIDECAR BOX INDICATE OPTIONAL EQUIPMENT CABINETS.
 4. BACKFEED PROTECTION IS NOT PROVIDED AS A PART OF UPS. CUSTOMER SUPPLIED BYPASS INPUT BREAKER WITH 48-60VDC SHUNT TRIP IS REQUIRED.

Figure 25. Eaton 93PM-L 120 kW UPS with SIAC-B (Bypass Sidecar) System Online

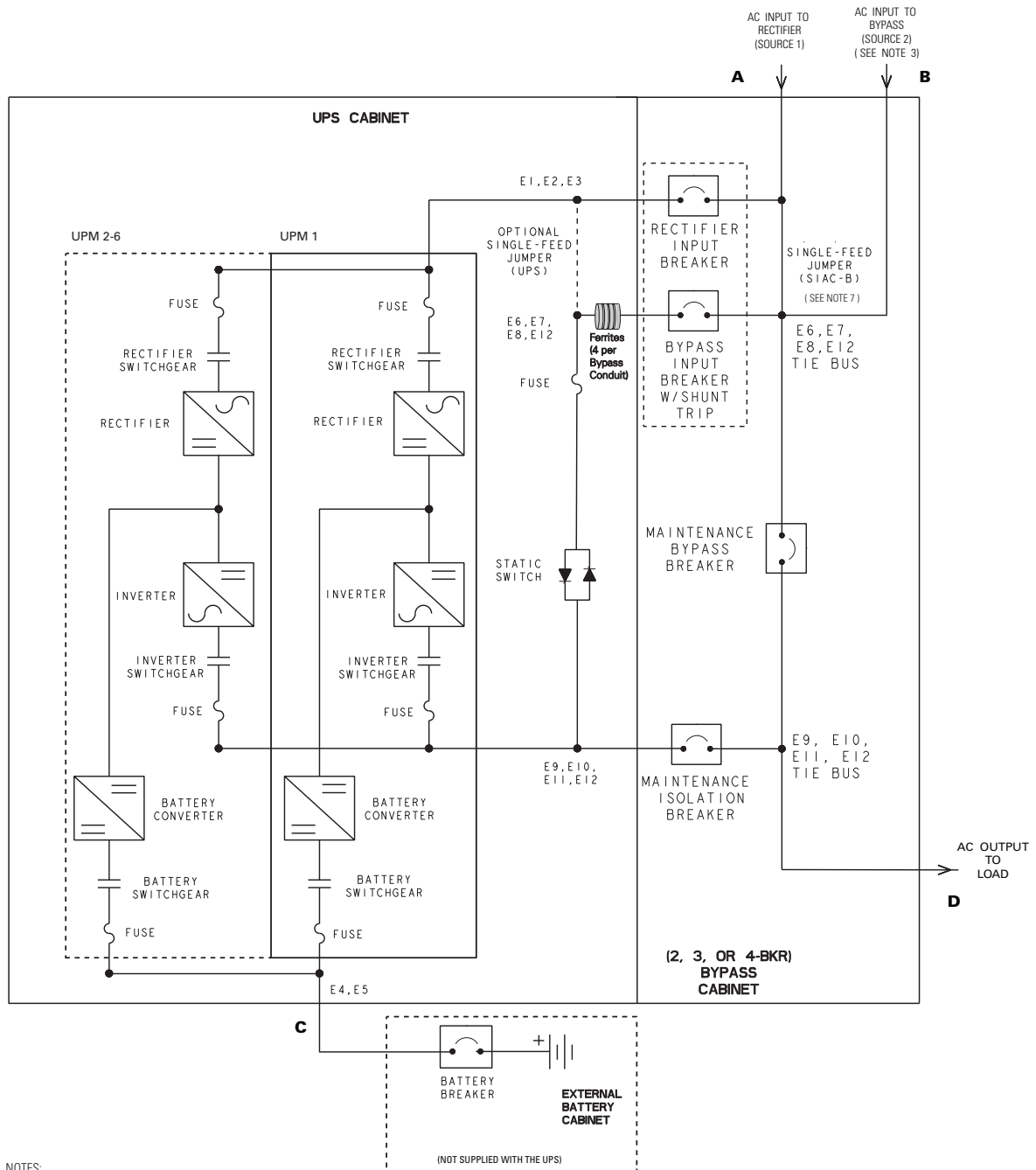

NOTES:

1. AC INPUT TO RECTIFIER IS NOT USED IN SINGLE FEED CONFIGURATION.
2. DASHED LINES INSIDE OF UPS BOX INDICATE OPTIONAL UPM'S OR INTERNAL BATTERIES. CONFIGURABLE FROM 1-6 UPMs.
3. DASHED LINES INSIDE OF SIAC-B BOX INDICATE OPTIONAL COMPONENTS OR BYPASS JUMPER.
4. DASHED LINES OUTSIDE OF UPS OR SIAC-B BOX INDICATE OPTIONAL EQUIPMENT CABINETS.
5. BACKFEED PROTECTION IS NOT PROVIDED AS A PART OF UPS. CUSTOMER SUPPLIED BYPASS INPUT BREAKER WITH 48-60VDC SHUNT TRIP IS REQUIRED IF BYPASS SIDE CAR DOES NOT INCLUDE BIB BREAKER.
6. THE SINGLE-FEED JUMPER (UPS) IS FACTORY INSTALLED WHEN THE UPS IS ORDERED WITH A 2 OR 3 BREAKER SIDE CAR.
7. THE SINGLE FEED JUMPER (SIAC-B) IS FACTORY INSTALLED WHEN THE UPS IS ORDERED WITH A 4-BREAKER SIDE CAR. THE JUMPER MUST BE REMOVED FOR A DUAL FEED INSTALLATIONS. THE 4-BREAKER SIDE CAR IS ONLY AVAILABLE WITH A DUAL FEED UPS.

Chapter 7 Maintenance

7.1 Maintenance

The components inside the accessory cabinet are secured to a sturdy metal frame. All repairable parts and assemblies are located for easy removal, with very little disassembly. This design allows authorized service personnel to perform routine maintenance and servicing quickly.

You must schedule periodic performance checks of the UPS system to keep it running properly. Regular routine checks of operation and system parameters enable your system to function efficiently for many trouble-free years.

7.1.1 Important Safety Instructions

Remember that your UPS system is designed to supply power **EVEN WHEN DISCONNECTED FROM THE UTILITY POWER.**



- No user serviceable components.
 - Servicing and maintenance should be performed by qualified service personnel only.
 - LETHAL VOLTAGE PRESENT. This unit should not be operated with the cabinet doors open or protective panels removed. Do not make any assumptions about the electrical state of any cabinet in the UPS system. Failure to follow these instructions may result in serious injury or death.
-

7.2 Performing Preventive Maintenance

The UPS system requires very little preventive maintenance. However, the system should be inspected periodically to verify that the units are operating normally. Record maintenance results and any corrective actions in a suitable log.

7.2.1 DAILY Maintenance

Perform the following steps daily:

1. Check the area surrounding the UPS system. Ensure the area is not cluttered, allowing free access to the unit.
2. Ensure the air intakes on the accessory cabinets are not blocked.
3. Ensure the operating environment is within the parameters specified in paragraph **3.3.1 Environmental and Installation Considerations** and Chapter **9 Product Specifications**.

7.2.2 PERIODIC Maintenance

Periodic inspections of the UPS and accessory cabinets should be made to determine if components, wiring, and connections exhibit evidence of overheating. Particular attention should be given to the compression lug connections. Maintenance procedures should specify that the compression lug connections be retorqued to values listed in this manual.

7.2.3 ANNUAL Maintenance

Annual preventive maintenance should be performed only by authorized service personnel familiar with maintenance and servicing of the UPS system. Contact an Eaton service representative for more information about service offerings.

7.3 Maintenance Training

A basic training course, available from Eaton, gives you a competent working knowledge of the UPS system operation and teaches you how to perform first level corrective maintenance. For more information about training and other services, contact the Customer Reliability Center (see paragraph **1.8 Getting Help**).

Chapter 8 Product Specifications

8.1 Product Specifications

This section provides the following specifications:

- Model configurations
- Input specifications
- Output specifications
- Environmental and safety specifications

8.1.1 Models

The Sidecar Integrated Accessory Cabinet is available in the model configurations listed below to meet the needs of the Eaton 93PM-L 60 kW and 93PM-L 120 kW UPS product lines.

Sidecar Integrated Accessory Cabinet Models	Description
Eaton 93PM-L 60 kW Top Entry Sidecar	Empty sidecar for Top Entry wiring of the 93PM-L 60 kW UPS
Eaton 93PM-L 60 kW SIAC-B	SIAC-B (Bypass Sidecar - two, three or four breaker variants) for the Eaton 93PM-L 60 kW UPS
Eaton 93PM-L 120 kW Top Entry Sidecar	Empty sidecar for Top Entry wiring of the 93PM-L 120 kW UPS
Eaton 93PM-L 120 kW SIAC-B	SIAC-B (Bypass Sidecar - two, three or four breaker variants) for the Eaton 93PM-L 120 kW UPS

8.2 Specifications

The following sections detail the input, output, and environmental and safety specifications for the Eaton 93PM-L SIAC.

8.2.1 Input

Operating Input Voltage	208 or 220 Vac
Operating Input Frequency Range	50/60 Hz
Operating Input Wiring	4 wire + ground
Operating Input Current	See Table 3 through Table 7 .

8.2.2 Output

Operating Output Voltage	208 or 220 Vac
Operating Output Frequency Range	50/60 Hz
Operating Output Wiring	4 wire + ground
Operating Input Current	See Table 3 through Table 7 .

8.2.3 Environmental and Safety Specifications

Operating Temperature	5 to 40 °C (41 to 104°F) without derating. The recommended operating temperature is 25° C (77°F)
Storage Temperature	-25 to +55°C (-13 to +131°F)
Operating Altitude	Maximum 1500m (5000 ft) at 40°C without derating
Ventilation	Convection
Relative Humidity (operating and storage)	5% to 95% maximum noncondensing
Acoustical Noise	Not applicable
Safety Conformance	UL1778 5 th edition
Agency Markings	cULus

Chapter 9 Warranty

9.1 Warranty

Limited FACTORY WARRANTY for Three-Phase Eaton 93PM UPS and 93PM UPS Accessory Products

WARRANTOR: The warrantor for the limited warranties set forth herein is Eaton ("Eaton").

LIMITED WARRANTY: This limited warranty (this "Warranty") applies only to the original end-user (the "End-User") of the Eaton Three-Phase 93PM UPS and 93PM UPS Accessory Products (the "Product") and cannot be transferred. This restriction applies even in the event that the Product is initially sold by Eaton for resale to an End-User. This Warranty gives you specific legal rights, and you may also have other rights which vary from State to State (or jurisdiction to jurisdiction).

WHAT THIS LIMITED WARRANTY COVERS: The warrantor warrants, with the terms of this Warranty, that the Eaton three-phase UPS electronics, Eaton-built accessories, and Eaton-built battery cabinets (individually and collectively, the "Warranted Items") are free from defects in material and workmanship.

For Product installed (and currently located) in the fifty (50) United States and the District of Columbia, if, in the opinion of Eaton, a Warranted Item is defective, Eaton's sole obligation, at the option of Eaton, will be to refurbish or replace such defective Warranted Item (including the costs of providing diagnosis, service, and labor ["labor coverage"]). The defective Warranted Item will be refurbished or replaced onsite at the End-User's location or such other location as determined by Eaton. Any parts that are replaced may be new or reconditioned. All parts replaced by Eaton shall become the property of Eaton.

For Product installed (and currently located) outside the fifty (50) United States and the District of Columbia, if, in the opinion of Eaton, a Warranted Item is defective, Eaton's sole obligation, at the option of Eaton, will be to refurbish or replace such defective Warranted Item (not including the costs of labor coverage). The defective Warranted Item will be refurbished or replaced onsite at the End-User's location or such other location as determined by Eaton. Any parts that are replaced may be new or reconditioned. All parts replaced by Eaton shall become the property of Eaton.

LIMITED WARRANTY PERIOD: The period covered by this Warranty for Product installed (and currently located) in the fifty (50) United States and the District of Columbia is six (6) months from the date of Product purchase for labor coverage when no startup is performed by an authorized Eaton Customer Service Engineer or Agent or twelve (12) months from the date of Product purchase with startup performed by an authorized Eaton Customer Service Engineer or Agent and twelve (12) months from the date of Product purchase or eighteen (18) months from date of Product shipment, whichever occurs first, for the refurbishment/replacement of parts.

The period covered by this Warranty for Product installed (and currently located) outside the fifty (50) United States and the District of Columbia is twelve (12) months from the date of Product purchase or eighteen (18) months from the date of Product shipment, whichever occurs first, for the refurbishment/replacement of parts.

WHAT THIS LIMITED WARRANTY DOES NOT COVER: This Warranty does not cover any defects or damages caused by: (a) failure to properly store the Product before installation, including the "trickle charge" of batteries no later than the date indicated on the packaging; (b) shipping and delivery of the Product if shipping is FOB Factory; (c) neglect, accident, fire, flood, lightning, vandalism, acts of God, Customer's neglect, abuse, misuse, misapplication, incorrect installation; (d) repair or alteration not authorized in writing by Eaton personnel or performed by an authorized Eaton Customer Service Engineer or Agent; or (e) improper testing, operation, maintenance, adjustment, or any modification of any kind not authorized in writing by Eaton personnel or performed by an authorized Eaton Customer Service Engineer or Agent.

This Warranty is not valid: if the Product's serial numbers have been removed or are illegible. Any Warranted Items repaired or replaced pursuant to this Warranty will be warranted for the remaining portion of the original Warranty subject to all the terms thereof. Eaton does not provide a labor warranty for Product located outside of the fifty (50) United States or the District of Columbia. **Any equipment, parts, or materials included in the**

Product and not manufactured by Eaton are warranted solely by the manufacturer of such equipment, parts, or materials and are not included as part of this Warranty. Batteries are not warranted by Eaton.

THIS WARRANTY IS THE END-USER'S SOLE REMEDY AND IS EXPRESSLY IN LIEU OF, AND THERE ARE NO OTHER, EXPRESSED OR IMPLIED GUARANTEES OR WARRANTIES (INCLUDING ANY IMPLIED WARRANTY OF MERCHANTABILITY OR FITNESS FOR ANY PURPOSE, WHICH ARE EXPRESSLY DISCLAIMED). SOME STATES OR JURISDICTIONS DO NOT ALLOW THE EXCLUSION OF EXPRESS OR IMPLIED WARRANTIES, SO THE ABOVE EXCLUSION MAY NOT APPLY TO YOU. IN THAT EVENT, SUCH WARRANTIES ARE LIMITED IN DURATION TO THE LIMITED WARRANTY PERIOD. SOME STATES OR JURISDICTIONS DO NOT ALLOW LIMITATIONS ON HOW LONG AN IMPLIED WARRANTY LASTS OR THE EXCLUSION OR LIMITATION OF INCIDENTAL OR CONSEQUENTIAL DAMAGES, SO THE ABOVE LIMITATIONS AND/OR EXCLUSIONS MAY NOT APPLY TO YOU.

LIMITATION OF LIABILITY: In no event shall Eaton be liable for any indirect, incidental, special or consequential damages of any kind or type whatsoever, resulting from or in connection with any claim or cause of action, whether brought in contract or in tort (including negligence and strict liability). Some States or jurisdictions do not allow the exclusion of limitation of incidental or consequential damages, so the above limitation or exclusion may not apply to you. Eaton shall not be responsible for failure to provide service or parts due to causes beyond Eaton's reasonable control. In no case will Eaton's liability under this Warranty exceed the replacement value of the Warranted Items.

END-USER'S OBLIGATIONS: In order to receive the benefits of this Warranty, the End-User must register the product warranty (via mail or online at www.eaton.com/pg/register "product registration"); use the Product in a normal way; follow the Product's user's guide; and protect against further damage to the Product if there is a covered defect.

OTHER LIMITATIONS: Eaton's obligations under this Warranty are expressly conditioned upon receipt by Eaton of all payments due to it (including interest charges, if any). During such time as Eaton has not received payment of any amount due to it for the Product, in accordance with the contract terms under which the Product is sold, Eaton shall have no obligation under this Warranty. Also during such time, the period of this Warranty shall continue to run and the expiration of this Warranty shall not be extended upon payment of any overdue or unpaid amounts.

COSTS NOT RELATED TO WARRANTY: The End-User shall be invoiced for, and shall pay for, all services not expressly provided for by the terms of this Warranty, including without limitation site calls involving an inspection that determines no corrective maintenance is required. Any costs for replacement equipment, installation, materials, freight charges, travel expenses, or labor of Eaton representatives outside the terms of this Warranty will be borne by the End-User.

OBTAINING WARRANTY SERVICE: In the USA, call the Eaton Customer Reliability Center 7x24 at 800-843-9433. Outside of the USA, call your local Eaton sales or service representative, or call the Eaton Customer Reliability Center in the United States at 919845-3633. For comments or questions about this Limited Factory Warranty, write to the Customer Quality Representative, 8609 Six Forks Road, Raleigh, North Carolina 27615 USA.



P-164000822 01