

# Eaton® 93PM-L Integrated Accessory Cabinet - Bypass

160kW (208V) 4-Wire IAC-B

200kW (208V) 4-Wire IAC-B

Installation and Operation Manual



*Powering Business Worldwide*

p/n: P-164000764  
Revision 01

---

**IMPORTANT SAFETY INSTRUCTIONS SAVE THESE INSTRUCTIONS**

---

This manual contains important instructions that you should follow during installation and maintenance of the UPS and batteries. Please read all instructions before operating the equipment and save this manual for future reference.

---

---

**CONSIGNES DE SÉCURITÉ IMPORTANTES – CONSERVER CES INSTRUCTIONS**

---

Ce manuel comporte des instructions importantes que vous êtes invité à suivre lors de toute procédure d'installation et de maintenance des batteries et de l'onduleur. Veuillez consulter entièrement ces instructions avant de faire fonctionner l'équipement et conserver ce manuel afin de pouvoir vous y reporter ultérieurement.

---

Eaton reserves the right to change specifications without prior notice. Eaton is a registered trademark of Eaton. KIRK is a registered trademark of Kirk Key Interlock company, LLC, a subsidiary of Halma plc. National Electrical Code and NEC are registered trademarks of National Fire Protection Association, Inc. Superflex is a registered trademark of LUTZE Systematic Technology. All other trademarks are property of their respective companies.

©Copyright 2018 Eaton, Raleigh, NC, USA. All rights reserved. No part of this document may be reproduced in any way without the express written approval of Eaton.

# Table of Contents

<b>1 Introduction</b>	<b>1</b>
1.1 Introduction	1
1.2 Features	2
1.3 Installation Features	2
1.4 Model Configurations	2
1.5 Using This Manual	5
1.6 Conventions Used in This Manual	6
1.7 Symbols, Controls, and Indicators	6
1.8 For More Information	7
1.9 Getting Help	7
1.10 Equipment Registration	8
<b>2 Safety</b>	<b>9</b>
2.1 Safety Warnings	9
<b>3 Installation Plan and Unpacking</b>	<b>11</b>
3.1 Installation Plan and Unpacking	11
3.1.1 Creating an Installation Plan	11
3.2 Preparing the Site	11
3.2.1 Environmental and Installation Considerations	11
3.2.2 IAC-B Interface Wiring Preparation	18
3.2.3 IAC-B Power Wiring Preparation	19
3.3 Inspecting and Unpacking the IAC-B	23
<b>4 Installation</b>	<b>25</b>
4.1 IAC-B Installation	25
4.1.1 Preliminary Installation Information	25
4.2 Unloading the IAC-B from the Pallet	25
4.3 Installing the IAC-B Interface Connections	28
4.3.1 MBP Auxiliary Contact Interface Connections	28
4.3.2 MIS Interface Connections	33
4.3.3 BIB Interface and Shunt Trip Connections (if installed)	34
4.3.4 RIB Interface Connections (if installed)	35
4.3.5 Trapped Key Interface Connections (if installed)	36
4.4 Two-Hole Barrel Lug Terminations to Bus Bar Installation	38
4.5 Installing IAC-B External Power Wiring	39
4.5.1 IAC-B with a 2, 3 or 4-Breaker Single Feed Configurations	41
4.5.2 IAC-B with a 4-Breaker Dual Feed Configuration (MBP, MIS, BIB and RIB)	45
4.5.3 UPS to IAC-B Breaker Wiring	48
4.6 Initial Startup	51
4.7 Completing the Installation Checklist	51

# Table of Contents

4.7.1 Installation Checklist.....	51
<b>5 Onelines, Schematics, and Wiring Diagrams.....</b>	<b>53</b>
5.1 <b>Onelines, Schematics, and Wiring Diagrams</b> .....	53
5.1.1 Onelines.....	53
5.1.2 Schematics.....	54
5.1.3 Terminal Block Wiring Diagrams.....	57
<b>6 Operation.....</b>	<b>59</b>
6.1 IAC-B Operating Instructions.....	59
6.1.1 IAC-B Breakers.....	59
6.2 Using the UPS when an IAC-B is Installed.....	59
6.3 IAC-B Operation – Sliding Interlock Plate.....	60
6.3.1 Transferring the UPS to Maintenance Bypass.....	60
6.3.2 Transferring the UPS from Maintenance Bypass.....	61
6.4 IAC-B Operation – Trapped Key Interlock.....	63
6.4.1 Transferring the UPS to Maintenance Bypass.....	63
6.4.2 Transferring the UPS from Maintenance Bypass.....	64
<b>7 Maintenance.....</b>	<b>67</b>
7.1 Maintenance.....	67
7.1.1 Important Safety Instructions.....	67
7.2 Performing Preventive Maintenance.....	67
7.2.1 DAILY Maintenance.....	67
7.2.2 PERIODIC Maintenance.....	67
7.2.3 ANNUAL Maintenance.....	67
7.3 Maintenance Training.....	68
<b>8 Product Specifications.....</b>	<b>69</b>
8.1 Product Specifications.....	69
8.1.1 Model Numbers.....	69
8.1.2 Specifications.....	69
8.1.2.1 Input.....	69
8.1.2.2 Output.....	69
8.1.2.3 Environmental and Safety Specifications.....	69
<b>9 Warranty.....</b>	<b>71</b>
9.1 Warranty.....	71

## List of Figures

Figure 1.	Eaton 93PM-L 160/200 kW IAC-B .....	1
Figure 2.	Eaton 93PM-L 160/200 kW IAC-B .....	3
Figure 3.	Eaton 93PM-L IAC-B (Left-side install) with Eaton 93PM-L UPS.....	4
Figure 4.	Eaton 93PM-L IAC-B (Right-side install) with Eaton 93PM-L UPS .....	5
Figure 5.	93PM-L IAC-B Cabinet Dimensions (Front, Right Side, and Back Views).....	14
Figure 6.	93PM-L IAC-B Dimensions (Top and Bottom Views) .....	15
Figure 7.	93PM-L IAC-B Center of Gravity .....	16
Figure 8.	Cabinet Ventilation – Rear Venting .....	17
Figure 9.	Cabinet Ventilation – Top Venting .....	17
Figure 10.	Eaton 93PM-L 160/200kW IAC-B as Shipped on Pallet .....	24
Figure 11.	Removing the Pallet Skids and Supports – Eaton 93PM-L IAC-B .....	26
Figure 12.	93PM-L IAC-B Interface Terminal Location .....	29
Figure 13.	Interface Wiring Location .....	30
Figure 14.	Wire Tie Anchors .....	31
Figure 15.	Interface Terminal Detail.....	31
Figure 16.	Typical Bus Bar Barrel Lug Mounting – Hardware Assembly Sequence .....	38
Figure 17.	Line-Up-and-Match Wiring Access Locations.....	40
Figure 18.	Top and Bottom Conduit Landing Wire Entry Locations .....	41
Figure 19.	IAC-B Single Feed Terminal Locations .....	43
Figure 20.	IAC-B Single Feed Upper Cabinet Terminal Detail.....	44
Figure 21.	IAC-B Lower Cabinet Terminal Detail.....	44
Figure 22.	IAC-B Dual Feed Terminal Locations.....	47
Figure 23.	IAC-B Dual Feed Upper Cabinet Terminal Detail.....	48
Figure 24.	IAC-B breaker Input Terminal Detail.....	50
Figure 25.	93PM-L 160/200kW IAC-B Oneline .....	53
Figure 26.	93PM-L 160/200kW IAC-B – 2 Breaker Maintenance Bypass .....	54
Figure 27.	93PM-L 160/200kW IAC-B – 3 Breaker Maintenance Bypass .....	55
Figure 28.	93PM-L 160/200kW IAC-B – 4 Breaker Maintenance Bypass .....	56
Figure 29.	IAC-B Terminal Block 1 – Wiring Diagram .....	57
Figure 30.	IAC-B Terminal Block 2 – Wiring Diagram .....	57
Figure 31.	IAC-B Terminal Block 3 – Wiring Diagram .....	58
Figure 32.	Eaton 93PM-L IAC-B Breakers — Sliding Plate Lockout .....	62
Figure 33.	Eaton 93PM-L IAC-B Breakers — Trapped Key Interlock .....	65
Figure 34.	Eaton 93PM-L IAC-B— Trapped Key Interlock Detail .....	66

List of Figures

## List of Tables

Table 1.	93PM-L IAC-B Cabinet Weights .....	12
Table 2.	IAC-B Cabinet Clearances.....	13
Table 3.	IAC-B Weight and Center of Gravity Dimensions .....	16
Table 4.	Input/Output Ratings and Wiring Recommendations .....	20
Table 5.	UPS External Power Cable Terminations .....	21
Table 6.	Supplied External Wiring Terminal Hardware Kit.....	22
Table 7.	Recommended Installation Parts and Tools (Not Supplied by Eaton) .....	22
Table 8.	IAC-B All Interface Wiring Terminal Block Terminations .....	32
Table 9.	IAC-B TB1 (MBP and MIS) Interface Terminals.....	32
Table 10.	IAC-B TB2 (BIB and RIB) Interface Terminals .....	35
Table 11.	IAC-B TB3 (Trapped Key) Interface Terminals.....	37

List of Tables



# Chapter 1 Introduction

## 1.1 Introduction

The Eaton® 93PM-L Integrated Accessory Cabinet-Bypass (IAC-B) is designed for use with the Eaton 93PM-L 160/200 kW (208V) Series Uninterruptible Power Supplies (UPSs). The IAC-B provides maintenance bypass functions with configurable features, enabling adaptation and expansion without costly electrical rework. The 93PM-L IAC-B is available in 160 kW or 200 kW rated versions, in either 2-Breaker, 3-Breaker or 4-Breaker configurations.

The IAC-B is housed in single free-standing cabinet with safety shields behind the doors for hazardous voltage protection. The cabinet matches the UPS cabinet in style and color.

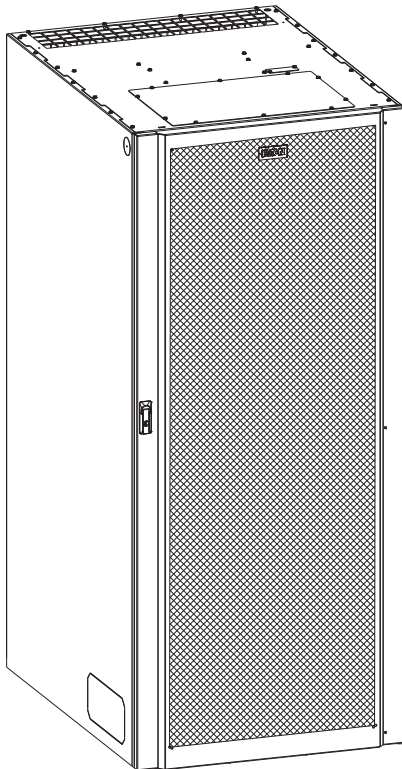
[Figure 1](#) shows the Eaton 93PM-L 160/200 kW IAC-B.

---

**NOTE** Startup and operational checks must be performed by an authorized Eaton Customer Service Engineer, or the warranty terms specified in paragraph [9.1 Warranty](#) become void. This service is offered as part of the sales contract for the UPS. Contact an Eaton service representative in advance (a minimum two-week notice is required) to reserve a preferred startup date.

---

**Figure 1. Eaton 93PM-L 160/200 kW IAC-B**



## 1.2 Features

The following descriptions provide a brief overview of the IAC-B functions:

- Two breaker configuration: The bypass sidecar contains only a Maintenance Bypass (MBP) and Maintenance Isolation (MIS) breaker. This allows Maintenance bypass for system repair or maintenance.
- Three breaker configuration (used with single-feed systems): Maintenance Bypass (MBP) and Maintenance Isolation (MIS) breakers, and a Bypass Input Breaker (BIB) enable power to completely bypass the UPS. The UPS can then be safely serviced or replaced without interrupting power to critical systems.
- Four breaker configuration (used with single and dual-feed systems): Maintenance Bypass (MBP) and Maintenance Isolation (MIS) breakers, and a Bypass Input Breaker (BIB) enable power to completely bypass the UPS. A Rectifier Input Breaker (RIB) provides a convenient method for removing power from the UPS when using the maintenance bypass to supply the load. The UPS can then be safely serviced or replaced without interrupting power to critical systems.

[Figure 3](#) and [Figure 4](#), show the IAC-B installed adjacent to the UPS cabinet.

## 1.3 Installation Features

- The IAC-B is designed to be installed in a line-up-and-match configuration:
  - The provided UPS to IAC-B breaker wiring is routed through the side panels between the UPS and the IAC-B.
  - The wiring to the bypass input, rectifier input and the output wiring is routed using external conduit through top or bottom entry conduit plates.
- To reduce installation time, connections to the input and output are made to easily accessible bus bar terminals via 2-hole crimp lugs (customer provided) located at the top and bottom of the cabinet.
- Top exhaust or rear exhaust venting is available.
- The cabinet is leveled using the provided leveling feet and can be secured in place using the optional floor mounting bracket kit.

A line-up-and-match IAC-B is installed adjacent to the UPS. The IAC-B may be installed on the right side or the left side of the UPS cabinet as viewed from the front of the cabinets. See [Figure 3](#) or [Figure 4](#) for line-up-and-match configuration views.

## 1.4 Model Configurations

The following model configurations are available:

- Eaton 93PM-L 160kW IAC-B (208V) and Eaton 93PM-L 200kW IAC-B (208V)  
Sliding Interlock plate or Trapped Key Interlock in the following configurations:
  - Right-mounted two breaker configuration containing a MBP and a MIS.
  - Right-mounted three breaker configuration containing a MBP, a MIS, and a BIB.
  - Right-mounted single input feed four breaker configuration containing a MBP, a MIS, a BIB, and a RIB.
  - Right-mounted dual input feed four breaker configuration containing a MBP, a MIS, a BIB, and a RIB.
  - Left-mounted two breaker configuration containing a MBP with auxiliary contacts and MIS.
  - Left-mounted three breaker configuration containing a MBP, a MIS, and a BIB.
  - Left-mounted single input feed four breaker configuration containing a MBP, a MIS, a BIB, and a RIB.
  - Left-mounted dual input feed four breaker configuration containing a MBP, a MIS, a BIB, and a RIB.

Figure 2. Eaton 93PM-L 160/200 kW IAC-B

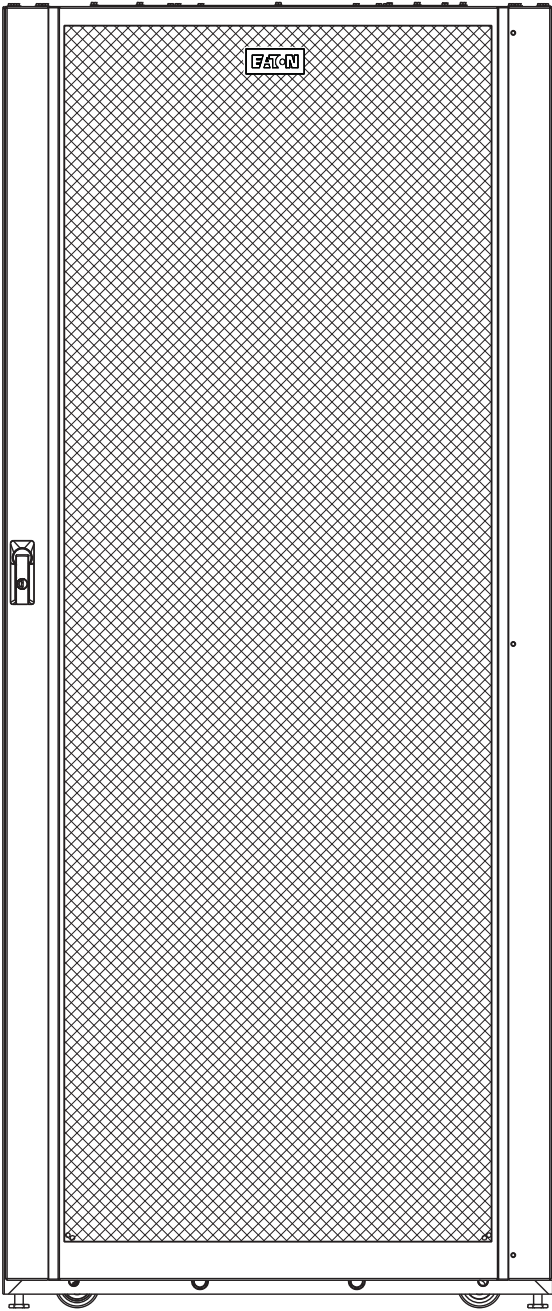
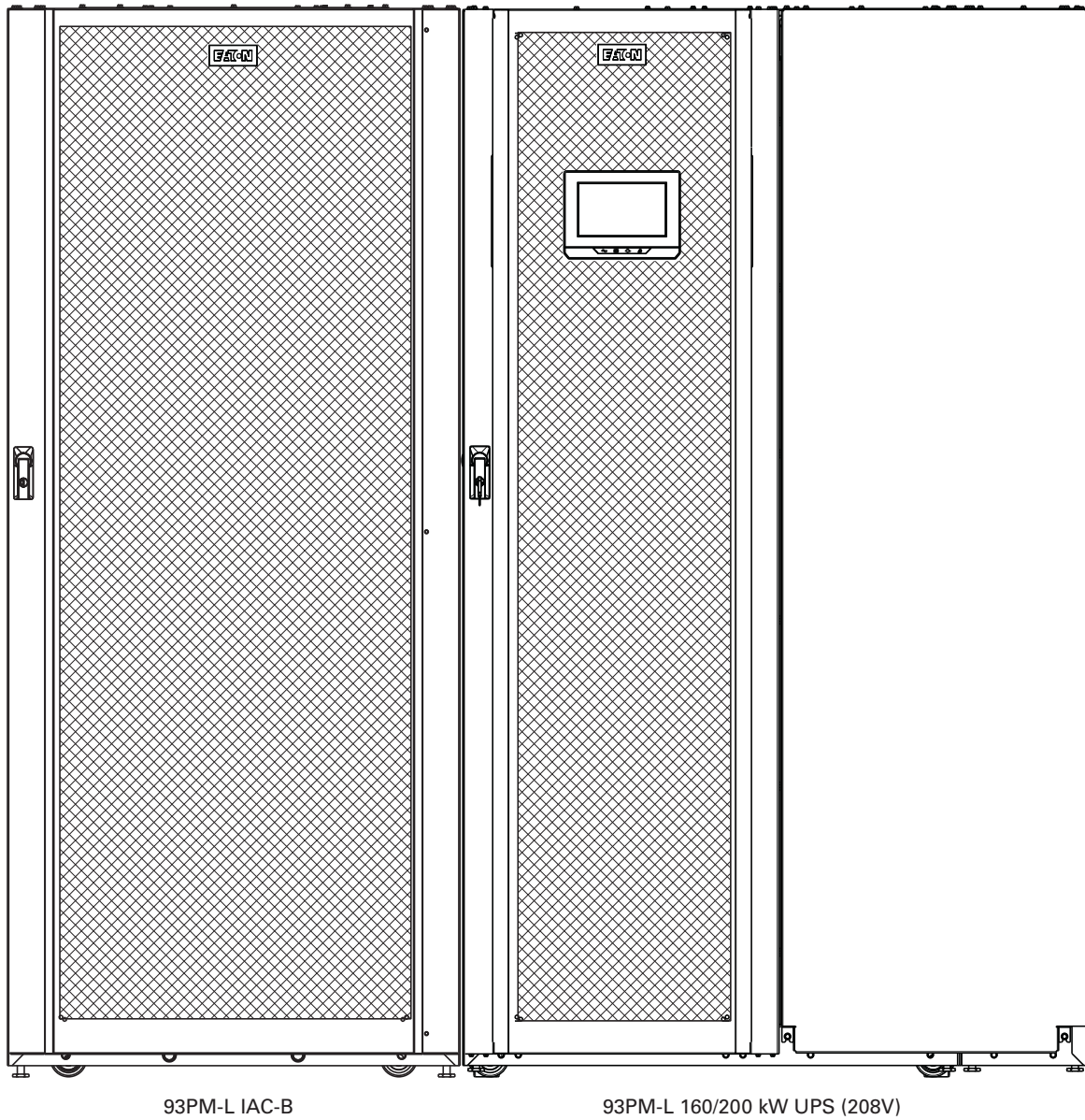
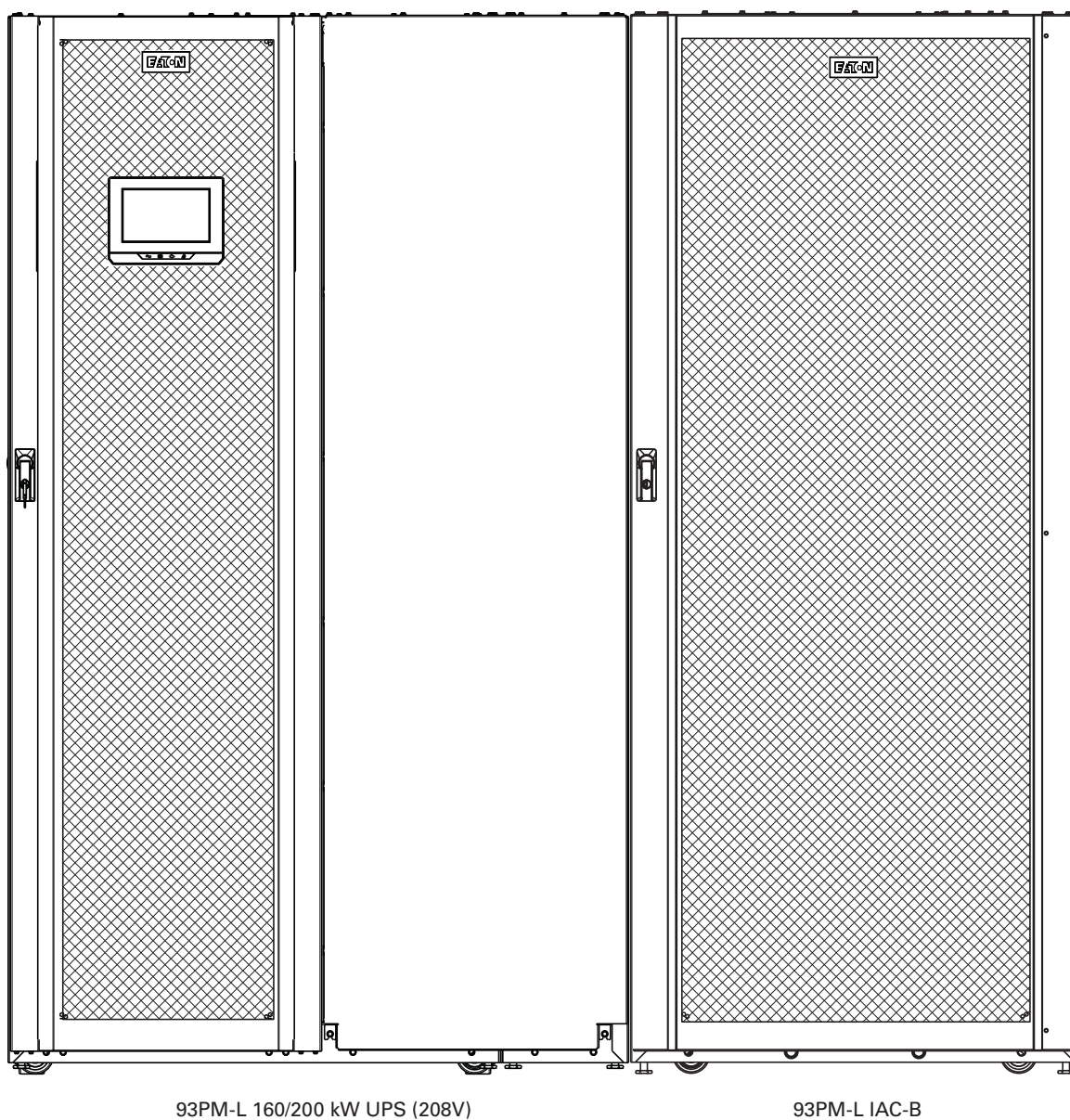


Figure 3. Eaton 93PM-L IAC-B (Left-side install) with Eaton 93PM-L UPS



**Figure 4. Eaton 93PM-L IAC-B (Right-side install) with Eaton 93PM-L UPS**

## 1.5 Using This Manual

This manual describes how to install the IAC-B and is divided into chapters. Read and understand the procedures described to ensure trouble-free installation and operation.

Read through each procedure before beginning work. Perform only those procedures that apply to the system being installed or operated.

## 1.6 Conventions Used in This Manual

This manual uses these type conventions:

- **Bold type** highlights important concepts in discussions, key terms in procedures, and menu options, or represents a command or option that you type or enter at a prompt.
- *Italic type* highlights new terms where they are defined.
- `Screen type` represents information that appears on the screen or LCD.

Icon	Description
<b>NOTE</b>	Information notes provide pertinent information about important features or instructions.
[Keys]	Brackets are used when referring to a specific key, such as [Enter] or [Ctrl].

In this manual, the term *UPS* refers only to the UPS cabinet and its internal elements. The term *UPS system* refers to the entire power protection system – the UPS cabinet, an external battery system, and options or accessories installed.

The term *line-up-and-match* refers to accessory cabinets that are physically located adjacent to the UPS. The term *standalone* refers to accessory cabinets that are located separate from the UPS.

## 1.7 Symbols, Controls, and Indicators

The following are examples of symbols used on the UPS or accessories to alert you to important information:



**RISK OF ELECTRIC SHOCK** - Observe the warning associated with the risk of electric shock symbol.



**CAUTION: REFER TO OPERATOR'S MANUAL** - Refer to your operator's manual for additional information, such as important operating and maintenance instructions.



This symbol indicates that you should not discard the UPS or the UPS batteries in the trash. This product contains sealed, lead-acid batteries and must be disposed of properly. For more information, contact your local recycling/reuse or hazardous waste center.



This symbol indicates that you should not discard waste electrical or electronic equipment (WEEE) in the trash. For proper disposal, contact your local recycling/reuse or hazardous waste center.

## 1.8 For More Information

Refer to the *Eaton 93PM-L UPS 20–160 kW (208V) Installation and Operation Manual* or the *Eaton 93PM-L UPS 20–200 kW (208V) Installation and Operation Manual* for the following additional information:

- UPS, optional components, and accessory installation instructions, including site preparation, planning for installation, wiring and safety information, and detailed illustrations of cabinets and optional accessories with dimensional and connection point drawings
- UPS operation, including UPS controls, functions of the UPS, standard features and optional accessories, procedures for starting and stopping the UPS, information about maintenance, communication capabilities and responding to system events
- Communication capabilities of the UPS system

Refer to the *Eaton 93PM Integrated Accessory Cabinet-Power Distribution (208V 4-Wire IAC-PD, 480V 3-Wire IAC-PD, 480V 4-Wire IAC-PD) Installation and Operation Manual* for the following additional information:

- Installation instructions, including site preparation, planning for installation, wiring and safety information, and detailed illustrations of cabinets with dimensional and connection point drawings
- Operation, including breakers, standard features and optional accessories, procedures for using the bypass functions, and information about maintenance

Refer to the *Eaton 93PM Remote Monitoring Device (RMD) Installation and Operation Manual* for additional installation and operating instructions.

Visit [www.eaton.com/powerquality](http://www.eaton.com/powerquality) or contact an Eaton service representative for information on how to obtain copies of these manuals.

## 1.9 Getting Help

If help is needed with any of the following:

- Scheduling initial startup
- Regional locations and telephone numbers
- A question about any of the information in this manual
- A question this manual does not answer

Please call the Customer Reliability Center at:

United States:	<b>1-800-843-9433</b>
Canada:	<b>1-800-461-9166 ext 2200</b>
All other countries:	<b>Call your local service representative</b>

Please use the following e-mail address for manual comments, suggestions, or to report an error in this manual:

**E-ESSDocumentation@eaton.com**

### 1.10 Equipment Registration

Please visit [www.eaton.com/pq/register](http://www.eaton.com/pq/register) to register your new Eaton UPS / Eaton UPS Accessory.

**Model Number:**

---

**Serial Number:**

---



## Chapter 2 Safety

### 2.1 Safety Warnings

---

#### **IMPORTANT SAFETY INSTRUCTIONS SAVE THESE INSTRUCTIONS**

---

This manual contains important instructions that should be followed during installation and maintenance of the UPS system and batteries. Read all instructions before operating the equipment and save this manual for future reference.

The UPS system is designed for industrial or computer room applications, and contains safety shields behind the door and front panels. However, the UPS system is a sophisticated power system and should be handled with appropriate care.

---

 **DANGER**

---

This UPS system contains LETHAL VOLTAGES. All repairs and service should be performed by AUTHORIZED SERVICE PERSONNEL ONLY. There are NO USER SERVICEABLE PARTS inside the UPS. Failure to follow these instructions may result in serious injury or death.

---

 **WARNING**

---

- The UPS system is powered by its own energy source (batteries). The output terminals may carry live voltage even when the UPS is disconnected from an AC source.
  - To reduce the risk of fire or electric shock, install this UPS system in a temperature and humidity controlled, indoor environment, free of conductive contaminants. Ambient temperature must not exceed 40°C (104°F). Do not operate near water or excessive humidity (95% maximum). The system is not intended for outdoor use.
  - As a result of the connected loads, high leakage current is possible. Connection to earth ground is required for safety and proper product operation. Do not check UPS system operation by any action that includes removal of the earth (ground) connection with loads attached.
  - Ensure all power is disconnected before performing installation or service.
  - ELECTRIC ENERGY HAZARD. Do not attempt to alter any UPS system or battery wiring or connectors. Attempting to alter wiring may result in serious injury or death.
-

---

 **CAUTION**

---

- Installation or servicing should be performed by qualified service personnel knowledgeable of UPS and battery systems, and required precautions. Keep unauthorized personnel away from equipment. Consider all warnings, cautions, and notes before installing or servicing equipment.
  - Keep the accessory cabinet doors closed and front panels installed to ensure proper cooling airflow and to protect personnel from dangerous voltages inside the unit.
  - Do not install or operate the UPS system close to gas or electric heat sources.
  - The operating environment should be maintained within the parameters stated in this manual.
  - Keep surroundings uncluttered, clean, and free from excess moisture.
  - Observe all DANGER, WARNING, and CAUTION notices affixed to the inside and outside of the equipment.
-

## Chapter 3 Installation Plan and Unpacking

### 3.1 Installation Plan and Unpacking

Use the following basic sequence of steps to install the Eaton 93PM-L 160/200 kW Integrated Accessory Cabinet-Bypass (IAC-B):

1. Create an installation plan for the IAC-B (Paragraph [3.1.1 Creating an Installation Plan](#)).
2. Prepare your site for the IAC-B (Paragraph [3.2 Preparing the Site](#)).
3. Inspect and unpack the IAC-B (Paragraph [3.3 Inspecting and Unpacking the IAC-B](#)).
4. Unload and install the IAC-B, and wire the system (Paragraph [4.1 IAC-B Installation](#)).
5. Complete the Installation Checklist (Paragraph [4.7 Completing the Installation Checklist](#)).
6. Have authorized service personnel perform preliminary operational checks and start up the UPS system.



#### NOTE

Startup and operational checks must be performed by an authorized Eaton Customer Service Engineer, or the warranty terms specified in Chapter **9 Warranty** become void. This service is offered as part of the sales contract for the UPS. Contact an Eaton service representative in advance (usually a two-week notice is required) to reserve a preferred startup date.

#### 3.1.1 Creating an Installation Plan

Before installing the IAC-B, read and understand how this manual applies to the system being installed. Use the procedures and illustrations in this section to create a logical plan for installing the IAC-B. This section contains the following information:

- Physical features and requirements, including dimensions
- Power wiring installation information

### 3.2 Preparing the Site

For the UPS system to operate at peak efficiency, the installation site should meet the environmental parameters outlined in this manual. The operating environment must meet the weight, clearance, and environmental requirements specified for the applicable accessory cabinet.

#### 3.2.1 Environmental and Installation Considerations

The UPS system installation, including the IAC-B, must meet the following guidelines:

- The system must be installed on a level floor suitable for computer or electronic equipment.
- The system must be operated at an altitude no higher than 1500m (5000 ft) without derating. For additional assistance with high altitude operation, contact an Eaton service representative (see paragraph [1.9 Getting Help](#)).
- The system must be installed in a temperature and humidity controlled indoor area free of conductive contaminants.
- Failure to follow guidelines may void your warranty.

The basic environmental requirements for operation of the IAC-B are:

- Recommended Operating Range: 5–40°C (41–104°F)
- Maximum Relative Humidity: 5–95%, noncondensing

The IAC-B operating environment must accommodate the weight requirements shown in [Table 1](#) and the size and space requirements shown in [Table 2](#) and [Figure 5](#).

**Table 1. 93PM-L IAC-B Cabinet Weights**

Rating	Breaker Interlock Option	Venting Option	IAC-B Breaker Configuration	Weight kg (lb)		
				Shipping	Installed	Point Loading
160 kW	Key Interlock	Top	2 Breakers	413 (911)	355 (782)	4 at 89 (196)
			3 Breakers	454 (1002)	396 (873)	4 at 99 (218)
			4 Breakers, Single Feed Input	490 (1082)	432 (953)	4 at 108 (238)
			4 Breakers, Dual Feed Input	498 (1099)	440 (970)	4 at 110 (243)
		Rear	2 Breakers	408 (900)	350 (771)	4 at 88 (193)
			3 Breakers	449 (991)	391 (862)	4 at 98 (216)
			4 Breakers, Single Feed Input	485 (1071)	427 (942)	4 at 107 (236)
			4 Breakers, Dual Feed Input	493 (1088)	435 (959)	4 at 109 (240)
	Slide Interlock	Top	2 Breakers	410 (903)	352 (774)	4 at 88 (194)
			3 Breakers	451 (994)	393 (865)	4 at 98 (216)
			4 Breakers, Single Feed Input	487 (1074)	429 (945)	4 at 107 (236)
			4 Breakers, Dual Feed Input	495 (1091)	437 (962)	4 at 109 (241)
		Rear	2 Breakers	405 (892)	347 (763)	4 at 87 (191)
			3 Breakers	446 (983)	388 (854)	4 at 97 (214)
			4 Breakers, Single Feed Input	482 (1063)	424 (934)	4 at 106 (234)
			4 Breakers, Dual Feed Input	490 (1080)	432 (951)	4 at 108 (238)
200 kW	Key Interlock	Top	2 Breakers	425 (938)	367 (809)	4 at 92 (202)
			3 Breakers	469 (1036)	411 (907)	4 at 103 (227)
			4 Breakers, Single Feed Input	509 (1124)	451 (995)	4 at 113 (249)
			4 Breakers, Dual Feed Input	518 (1144)	460 (1015)	4 at 115 (254)
		Rear	2 Breakers	420 (927)	362 (798)	4 at 91 (200)
			3 Breakers	464 (1025)	406 (896)	4 at 102 (224)
			4 Breakers, Single Feed Input	504 (1113)	446 (984)	4 at 112 (246)
			4 Breakers, Dual Feed Input	513 (1133)	455 (1004)	4 at 114 (251)
	Slide Interlock	Top	2 Breakers	422 (930)	364 (801)	4 at 91 (200)
			3 Breakers	466 (1028)	408 (899)	4 at 102 (225)
			4 Breakers, Single Feed Input	506 (1116)	448 (987)	4 at 112 (247)
			4 Breakers, Dual Feed Input	515 (1136)	457 (1007)	4 at 114 (252)
		Rear	2 Breakers	417 (919)	359 (790)	4 at 90 (198)
			3 Breakers	461 (1017)	403 (888)	4 at 101 (222)
			4 Breakers, Single Feed Input	501 (1105)	443 (976)	4 at 111 (244)
			4 Breakers, Dual Feed Input	510 (1125)	452 (996)	4 at 113 (249)

**NOTE** Shipping weight does not include the weight of the line-and-match wiring. Line-and-Match wiring is shipped on a separate pallet.

Air inlets are on the front of the cabinet. Outlets are in the back of the cabinet for the rear ventilation option or in the top of the cabinet for the top ventilation option.

Convection air cooling regulates internal component temperature through either of the following configurations:

- Rear ventilation (see [Figure 8](#)).
- Top ventilation (see [Figure 9](#)).

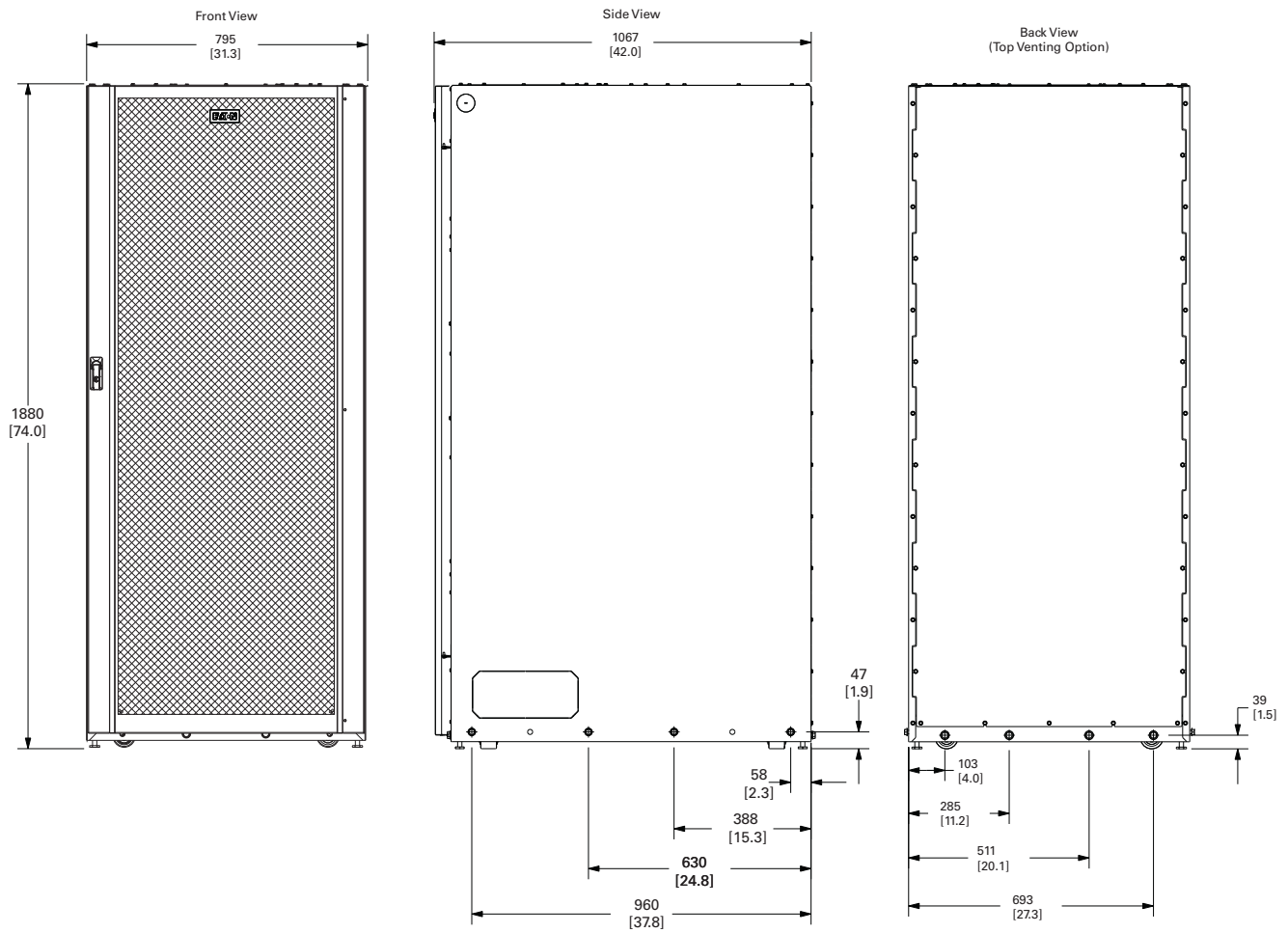
Allow clearance on top or in back of the cabinet depending on type of ventilation for proper air circulation. The clearances required around the IAC-B cabinet are shown in [Table 2](#).

**Table 2. IAC-B Cabinet Clearances**

<b>Viewing the IAC-B</b>	<b>Clearance</b>
<b>From Front of Cabinet</b>	914.4 mm (36") working space
<b>From Top of Cabinet with Top Venting</b>	203 mm (8") minimum clearance for ventilation*
<b>From Top of Cabinet with Rear Venting</b>	203 mm (8")*
<b>From Back of Cabinet with Rear Venting</b>	203 mm (8") minimum clearance for ventilation
<b>From Back of Cabinet with Top Venting</b>	None Required
<b>From Right Side of Cabinet</b>	None Required
<b>From Left Side of Cabinet</b>	None Required

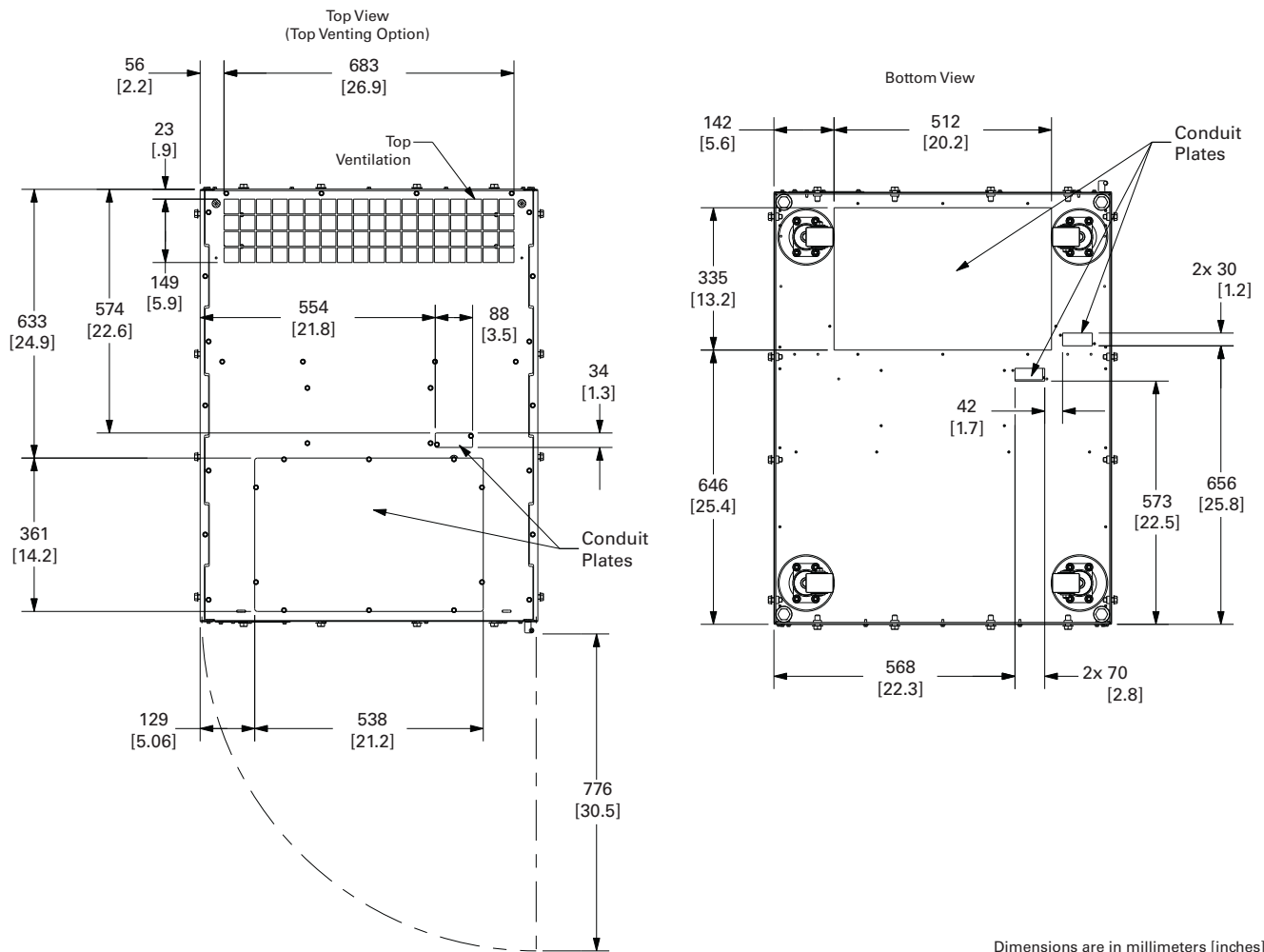
**NOTE** \*Additional Top of Cabinet clearance may be required for conduit in top entry applications.

**Figure 5. 93PM-L IAC-B Cabinet Dimensions (Front, Right Side, and Back Views)**



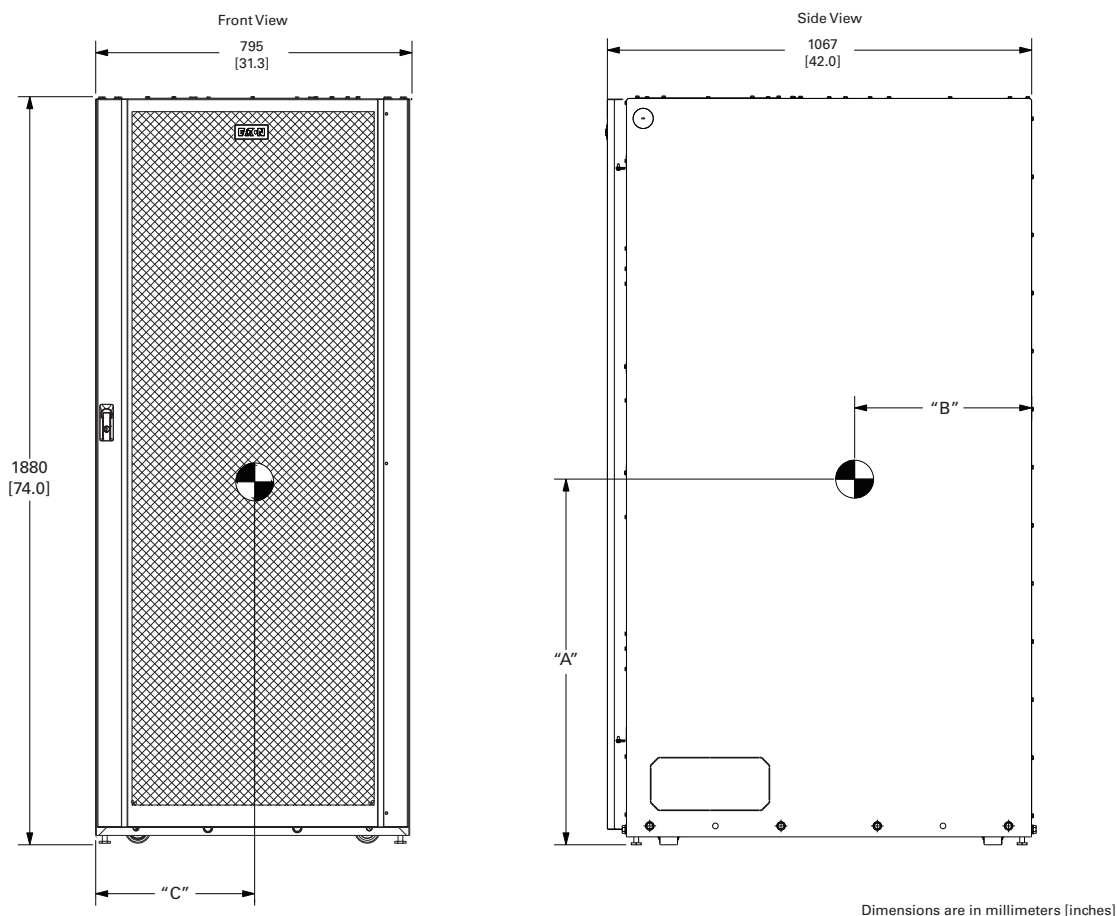
Dimensions are in millimeters [inches]

**Figure 6. 93PM-L IAC-B Dimensions (Top and Bottom Views)**



Dimensions are in millimeters [inches]

**Figure 7. 93PM-L IAC-B Center of Gravity**



Dimensions are in millimeters [inches]

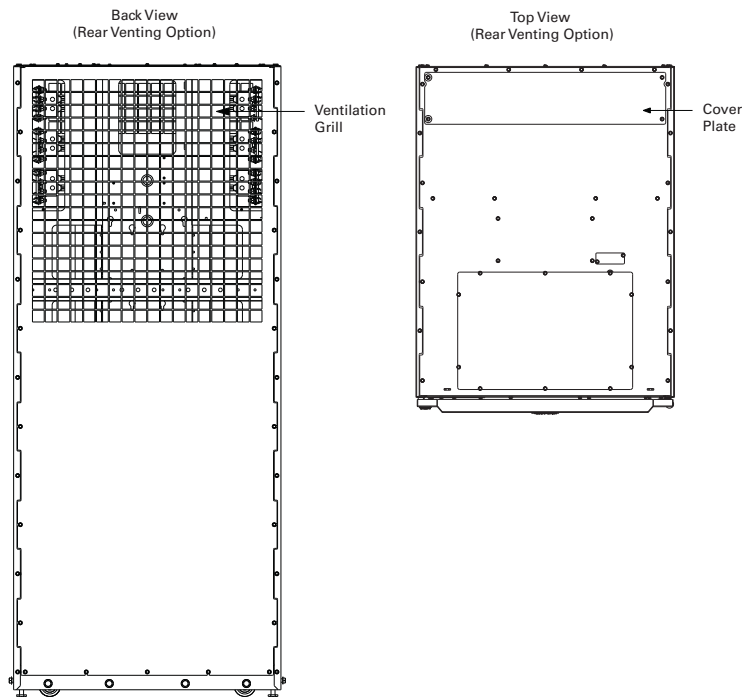
**Table 3. IAC-B Weight and Center of Gravity Dimensions**

Rating	IAC-B Model	A mm [inch]	B mm [inch]	C mm [inch]	Weight kg [lbs]
160 kW	2 Breakers	823.3 [32.4]	546.2 [21.5]	397.3 [15.6]	355 [782]
	3 Breakers	858.9 [33.8]	555.7 [21.9]	388.9 [15.3]	396 [873]
	4 Breakers, Single Feed Input	919.7 [36.2]	558.2 [22.0]	396.8 [15.6]	432 [953]
	4 Breakers, Dual Feed Input	932.6 [36.7]	557.1 [21.9]	396.8 [15.6]	440 [970]
200 kW	2 Breakers	823.3 [32.4]	546.2 [21.5]	397.3 [15.6]	367 [809]
	3 Breakers	858.9 [33.8]	555.7 [21.9]	388.9 [15.3]	411 [907]
	4 Breakers, Single Feed Input	919.7 [36.2]	558.2 [22.0]	396.8 [15.6]	451 [995]
	4 Breakers, Dual Feed Input	932.6 [36.7]	557.1 [21.9]	396.8 [15.6]	460 [1015]

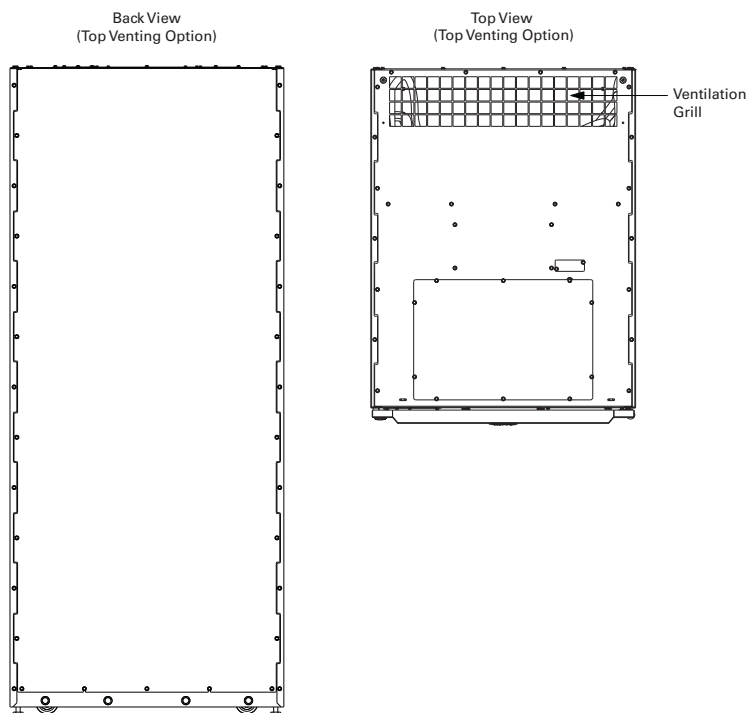
**NOTE** Weights do not include wiring between the UPS and the IAC-B or customer provided wiring.



**Figure 8. Cabinet Ventilation – Rear Venting**



**Figure 9. Cabinet Ventilation – Top Venting**



### 3.2.2 IAC-B Interface Wiring Preparation

Control wiring for features and options should be connected at the customer interface terminal blocks located inside the IAC-B.



#### **IMPORTANT**

---

Due to the size and quantity of input and output power wiring, it is recommended to install the interface wiring first, then install the input and output power wiring.

---



#### **WARNING**

---

Do not directly connect relay contacts to the mains related circuits. Reinforced insulation to the mains is required.

---

Read and understand the following notes while planning and performing the installation:

- Use Class 2 wiring methods (as defined by NEC Article 725) for interface wiring from 30V to 600V. The wire should be rated for 600V, 1A minimum. 12 AWG maximum wire size.
- Use twisted-pair wires for each input and return or common.
- Eaton provides interface wiring between the UPS and the IAC-B for MBP, MIS Aux contact and the BIB shunt trip. All other interface wiring and conduit is to be supplied by the customer.
- Interface wiring can be installed using the inter-cabinet wiring access pass-through or by routing wiring through conduit between cabinets.
- Install the interface wiring in separate conduit from the power wiring.
- Control wiring is run between the IAC-B and the UPS (wiring is provided).
- Control wiring from UPS to upstream connection is provided by the customer.

### 3.2.3 IAC-B Power Wiring Preparation

Read and understand the following notes while planning and performing the installation:



#### IMPORTANT

Due to the size and quantity of input and output power wiring, it is recommended to install the interface wiring first, then install the input and output power wiring.



#### WARNING

As a result of the connected loads high leakage current is possible. Connection to earth ground is required for safety and proper product operation. Do not check IAC-B operation by any action that includes removal of the earth (ground) connection with loads attached.

- 
- Refer to national and local electrical codes for acceptable external wiring practices.
  - For external maintenance bypass input, rectifier input, and output wiring, use copper wire with 75°C rated insulation. Wire sizes listed in [Table 4](#) are for copper wiring only. If wire is run in an ambient temperature greater than 40°C (104°F), higher temperature wire and/or larger size wire may be necessary. Wire sizes are based on using the specified breakers.
  - Recommended wire sizes are based on NFPA National Electrical Code® (NEC®) 70 Table 310.15(B)(16) 75°C ampacity with 40°C ambient correction factors.
  - Recommended wire sizes include de-ratings for 40°C environment and for neutral being treated as a current carrying conductor. Wire sizes must be based on national and local electric codes and the environment specific to the application.
  - Refer to NEC Article 250 and local codes for proper grounding practices.
  - Per NEC Article 300-20(B), all three-phase conductors must be run in the same conduit. Ground must be run in the same conduit as the phase conductors. Neutral must be run in the same conduit as the phase conductors.
  - Conduit is to be sized to accommodate three phase conductors, one ground conductor, and one neutral conductor.
  - Phase rotation must be clockwise starting with phase A (rotation A,B,C).
  - Material and labor for external wiring requirements are to be provided by the customer.
  - When installing an external maintenance bypass, all feeds to the UPS must have a service disconnect independent of the maintenance bypass power path. Most maintenance bypass solutions provide UPS input feeds derived from but isolated from the maintenance bypass power path. The source disconnect devices for maintenance bypass and the UPS input must be isolated but derived from the same voltage source. If the maintenance bypass solution being installed does not provide such functionality, DO NOT use a single feeder breaker to supply both the UPS and the maintenance bypass.
  - Refer to the appropriate Eaton 93PM-L UPS installation and operation manual listed in paragraph [1.8 For More Information](#) for UPS cabinet conduit and terminal specifications and locations.
  - The term line-up-and-match refers to accessory cabinets that are physically located adjacent to the UPS.

For external power wiring requirements, including the minimum AWG size of external wiring, see [Table 4](#). Wire sizes listed are for copper wiring only.



#### NOTE

“High strand count extra flexible” copper wire is recommended.

---

**Table 4. Input/Output Ratings and Wiring Recommendations**

	Units	Rating 50/60 Hz	
<b>Basic Unit Rating</b>	kW	160	200
<b>Input and Output Voltage</b>	Volts	208	208
<b>AC Input to Rectifier Input</b> (3) Phases, (1) Ground	Amps	568	710
Minimum Conductor Size (Phase A, B, and C) Number per Phase	AWG or kcmil (each)	300 MCM (3)	500 MCM (3)
Conduit Size Number	Inches (each)	2-1/2 (3)	3 (3)
Minimum Conductor Size (Ground) Number	AWG or kcmil (each)	4 (3)	3 (3)
<b>AC Input to Bypass Input</b> (3) Phases, (1) Neutral, (1) Ground	Amps	568	710
Neutral Current	Amps	769	962
Minimum Conductor Size (Phase A, B, and C) Number per Phase	AWG or kcmil (each)	500 MCM (3)	500 MCM (4)
Conduit Size Number	Inches (each)	3 (3)	3-1/2 (4)
Neutral Wire Size Number	AWG or kcmil (each)	4/0 (6)	350 MCM (8)
Minimum Conductor Size (Ground) Number	AWG or kcmil (each)	4 (3)	4 (4)
<b>AC Output to Critical Load</b> Full Load Current (3) Phases, (1) Neutral, (1) Ground	Amps	444	555
Neutral Current	Amps	769	962
Minimum Conductor Size (Phase A, B, and C) Number per Phase	AWG or kcmil (each)	300 MCM (3)	400 MCM (3)
Conduit Size Number	Inches (each)	3 (3)	3 (3)
Neutral Wire Size Number	AWG or kcmil (each)	4/0 (6)	300 MCM (6)
Minimum Conductor Size (Ground) Number	AWG or kcmil (each)	6 (3)	4 (3)

The power wiring terminals are 2-hole bus bar mountings for standard NEMA 2-hole barrel lugs. See [Table 5](#) for external power cable terminations. See [Table 6](#) for supplied external wiring terminal hardware and [Table 7](#) for recommended installation parts and tools not supplied by Eaton.

[Figure 19](#) through [Figure 23](#) show the IAC-B power terminal locations and detail.

**Table 5. UPS External Power Cable Terminations**

<b>Terminal Function</b>	<b>Terminal</b>	<b>Function</b>	<b>Bus Landings (using back-to-back lugs)</b>	<b>Tightening Torque Nm (lb in)</b>	<b>Screw Size and Type</b>
AC Input to Rectifier	E1	Phase A	4 – 2 bolt mounting	35 (310)	M12 Hex
	E2	Phase B	4 – 2 bolt mounting	35 (310)	M12 Hex
	E3	Phase C	4 – 2 bolt mounting	35 (310)	M12 Hex
AC Input to Bypass	E6	Phase A	4 – 2 bolt mounting	35 (310)	M12 Hex
	E7	Phase B	4 – 2 bolt mounting	35 (310)	M12 Hex
	E8	Phase C	4 – 2 bolt mounting	35 (310)	M12 Hex
	E12	Neutral	8 – 2 bolt mounting	35 (310)	M12 Hex
AC Output to Critical Load	E9	Phase A	4 – 2 bolt mounting	35 (310)	M12 Hex
	E10	Phase B	4 – 2 bolt mounting	35 (310)	M12 Hex
	E11	Phase C	4 – 2 bolt mounting	35 (310)	M12 Hex
	E12	Neutral	8 – 2 bolt mounting	35 (310)	M12 Hex
Customer Ground	Ground	Ground	14 - #14-1/0 pressure termination	5.1 (45)	Slotted

**Table 6. Supplied External Wiring Terminal Hardware Kit**

Part	Size	Quantity	Terminal Used On
Bolt, Grade 5	M12 x 35 mm	60	Rectifier Input, Bypass Input, Battery Input, and Output to Critical Load
Flat Washer	M12	60	Rectifier Input, Bypass Input, Battery Input, and Output to Critical Load
Conical Washer	M12	60	Rectifier Input, Bypass Input, Battery Input, and Output to Critical Load

**NOTE**

- The amount of supplied hardware varies based on the IAC-B breaker configuration ordered.
- Supplied hardware may be shipped in more than one box.
- For additional information (including part numbers and manufacturer information) and/or assistance contact an Eaton service representative (see paragraph [1.9 Getting Help](#)).

**Table 7. Recommended Installation Parts and Tools (Not Supplied by Eaton)**


Part	Size	Quantity	Notes
Long Barrel 2-Hole Lug	6 AWG	As Required	Copper wire only
	4 AWG		
	2 AWG		
	1 AWG		
	1/0 AWG		
	2/0 AWG		
	3/0 AWG		
	4/0 AWG		
	250 MCM		
	300 MCM		
	350 MCM		
500 MCM			
Manual Hydraulic Crimp Tool	14 Ton	1	
Die Set	N/A	1	

**NOTE** For additional information (including part numbers and manufacturer information) and/or assistance contact an Eaton service representative (see paragraph [1.9 Getting Help](#)).

### 3.3 Inspecting and Unpacking the IAC-B

The cabinet is shipped bolted to a wooden pallet and covered with outer protective packaging material (see [Figure 10](#)). The UPS to IAC-B inter-cabinet wiring is shipped in multiple boxes on a separate pallet from the cabinet.

---

**NOTE**  Startup and operational checks must be performed by an authorized Eaton Customer Service Engineer, or the warranty terms specified in Chapter [9.1 Warranty](#) become void. This service is offered as part of the sales contract for the UPS. Contact an Eaton service representative in advance (a minimum two-week notice is required) to reserve a preferred startup date.

---



---

**WARNING** 

---

The IAC-B is heavy (see [Table 1](#)). If unpacking and unloading instructions are not closely followed, the cabinet may tip and cause serious injury or death.

1. Carefully inspect the outer packaging for evidence of damage during transit.


---

**CAUTION** 

---

Do not install a damaged cabinet. Report any damage to the carrier and contact an Eaton service representative immediately.

---

**NOTE**  For the following step, verify that the forklift or pallet jack is rated to handle the weight of the cabinet (see [Table 1](#) for cabinet weight).

---

2. Use a forklift or pallet jack to move the packaged cabinet to the installation site, or as close as possible, before unpacking. If possible, move the cabinet using the pallet. Insert the forklift or pallet jack forks between the supports on the bottom of the pallet. See [Figure 7](#) and [Table 3](#) for the IAC-B center of gravity measurements.

---


**CAUTION** 

---

Do not tilt the IAC-B more than 10° from vertical or the cabinet may tip over.

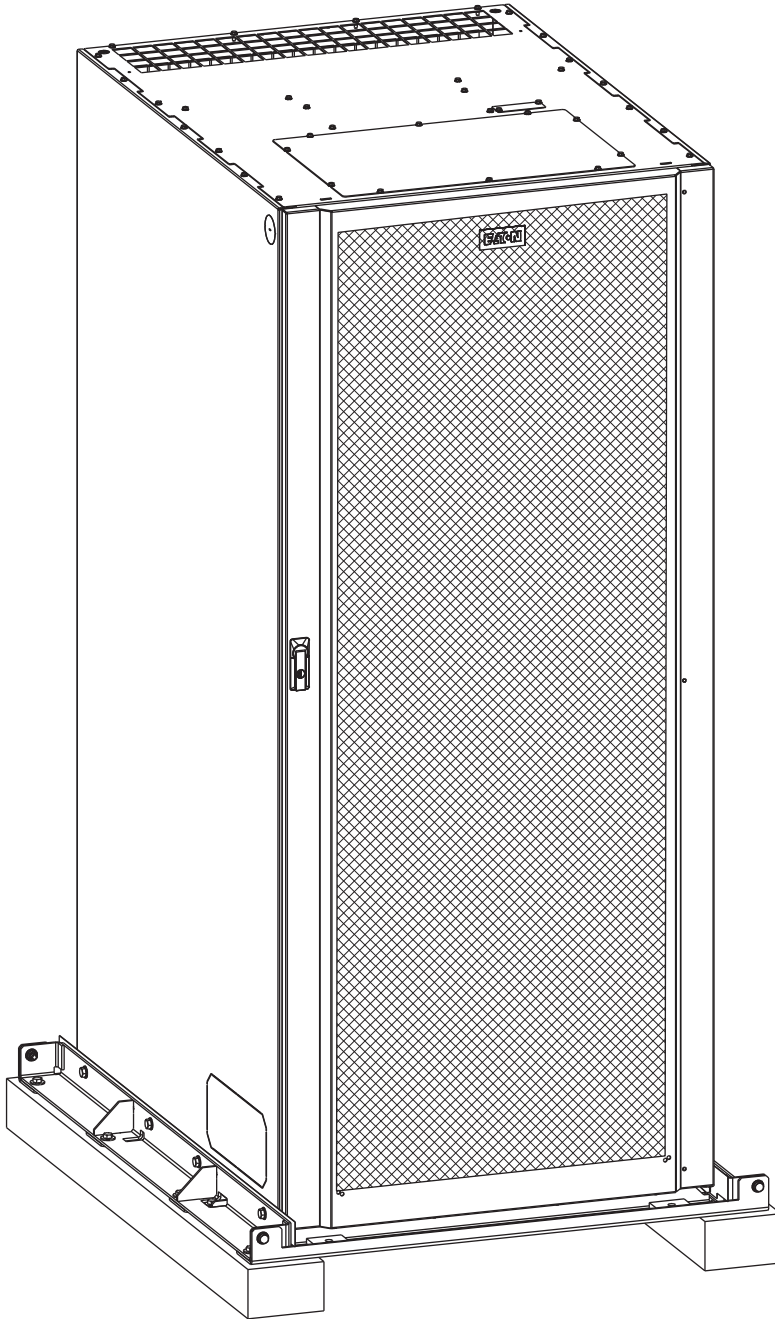
3. Set the pallet on a firm, level surface, allowing a minimum clearance of 3m (10 ft) on each side for removing the cabinet from the pallet.
4. Remove the protective packaging material from the cabinet and recycle in a responsible manner. Retain the parts kit box packed at the top of the cabinet.
5. Inspect the contents for any evidence of physical damage, and compare each item with the Bill of Lading. If damage has occurred or shortages are evident, contact an Eaton service representative immediately to determine the extent of the damage and its impact on further installation.

---

**NOTE**  While waiting for installation, protect the unpacked cabinet from moisture, dust, and other harmful contaminants. Failure to store and protect the IAC-B properly may void your warranty.

---

**Figure 10. Eaton 93PM-L 160/200kW IAC-B as Shipped on Pallet**





## Chapter 4 Installation

### 4.1 IAC-B Installation

This chapter contains installation instructions, including unloading, power wiring, and interface wiring, for the Integrated Accessory Cabinet-Bypass (IAC-B).

#### 4.1.1 Preliminary Installation Information

---

 **WARNING**

---

Installation should be performed only by qualified personnel.

- Refer to paragraph [3.2 Preparing the Site](#) for cabinet dimensions, equipment weight, wiring and terminal data, and installation notes.
- Remove conduit landing plates to add conduit landing holes as required.

### 4.2 Unloading the IAC-B from the Pallet

---

 **DANGER**

---

RISK OF INSTABILITY. Do not remove any internal panels until the cabinet is removed from and lowered from the pallet. Failure to follow these instructions can result in serious injury or death.

---

 **WARNING**

---

The IAC-B is heavy (see [Table 1](#)). If unpacking and unloading instructions are not closely followed, the cabinet may tip and cause serious injury or death.


---

 **CAUTION**

---

- Do not tilt cabinet more than 10° from vertical.
- Lift the cabinet only with a forklift or damage may occur.

---

 **NOTE** For the following steps, verify that the forklift or pallet jack is rated to handle the weight of the cabinet (see [Table 1](#) for cabinet weights).

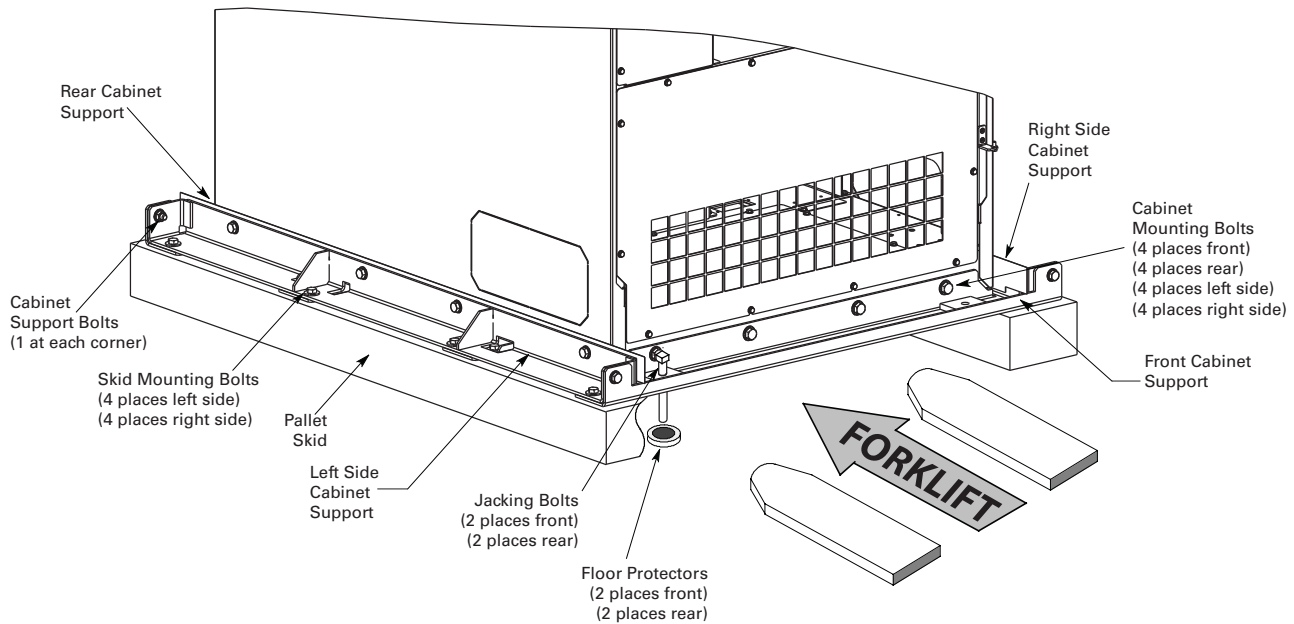
---

The IAC-B is bolted to a pallet consisting of four metal angle supports secured to two wood supports. To remove the pallet:

1. If not already accomplished, use a forklift or pallet jack to move the IAC-B to the installation area, or as close as possible, before unloading from the pallet. Insert the forklift or pallet jack forks between the supports on the bottom of the pallet (see [Figure 7](#) and [Table 3](#) for the UPS cabinet center of gravity measurements).
2. Open the front door by lifting the latch from the bottom and turning to the right (counterclockwise) and swing the door open.
3. Locate the four 1/2" jacking bolts from the parts kit and install them in the threaded holes in the front and rear supports as shown in [Figure 11](#). Place a floor protector from the parts kit underneath each jacking bolt, and screw the bolts down against them.

The floor protectors protect the floor from being marred by the jacking bolts.

**Figure 11. Removing the Pallet Skids and Supports – Eaton 93PM-L IAC-B**




---

**⚠ WARNING**

---

Do not remove or loosen the cabinet mounting or cabinet support bolts until instructed.

---

- Loosen, but do not remove, the skid mounting bolts holding the pallet skids to the left and right side supports, and to the front and rear supports (see [Figure 11](#)).
- 

**⚠ WARNING**

---

**RISK OF INSTABILITY.** Turning the jacking bolts unevenly may cause the cabinet to become unbalanced. To prevent tipping the cabinet, raise the IAC-B no more than 3 mm (1/8") above the floor (just enough to allow the removal of the pallet skids). Failure to follow these instructions can result in serious injury or death.

---

- Turn each jacking bolt consecutively, two full turns, until the pallet skids clear the floor by approximately 3 mm (1/8").
  - Remove the hardware loosened in [Step 4](#)
  - Pull the pallet skids out from under the metal angle supports without disturbing the jacking bolts. Recycle the pallet skids and hardware in a responsible manner.
- 

**⚠ CAUTION**

---

**CABINET MAY FALL.** Do not loosen the hardware attaching the front supports to the cabinet base. The cabinet must be lowered by the jacking bolts before the supports can be removed.

---

8. Carefully and evenly **lower the cabinet by turning each jacking bolt consecutively two full turns (maximum)** until the casters contact the floor and the cabinet is no longer supported by the jacking bolts.
9. After the IAC-B is resting on the floor, remove the jacking bolts and floor protectors. Recycle them in a responsible manner.
10. Remove the cabinet support bolts fastening the front, rear, and side cabinet supports together and remove the side supports (see [Figure 11](#)).
11. Remove the cabinet mounting bolts holding the front and rear supports to the cabinet base.
12. Recycle the bolts along with the support brackets in a responsible manner.
13. Close the door and secure the latch.
14. If the leveling feet are not retracted, turn all four leveling feet until they are retracted as far into the cabinet as possible.



**NOTE**

The IAC-B may be located to either the right or left of the UPS cabinet.

---

15. Remove the round inter-cabinet knockout and the rectangular inter-cabinet wiring access knockout on the side of the UPS and the IAC-B's side that will mate up with the UPS (see [Figure 17](#)).
16. The IAC-B installs adjacent to the UPS in a line-up-and-match configuration, (see [Figure 3](#) or [Figure 4](#)).



**CAUTION**

To prevent tipping when rolling the cabinet and damage to the front door, push the cabinet from the rear whenever possible. Do not push the cabinet from the sides.

---

17. Roll the cabinet to the final installation location.
18. Lower the IAC-B's leveling feet until the cabinet is level with the adjacent UPS.
19. Locate the top splice bracket shipped with the IAC-B.
20. Remove the screws along each adjacent cabinet top panel securing the top panels. Retain the hardware for later use.
21. Install the top splice bracket between the adjacent cabinet and secure the tie strap with retained hardware.



**NOTE**

Optional front and back floor mounting brackets are available to order for permanently mounting the IAC-B.

---

22. If permanently mounting the IAC-B, proceed to [Step 23](#); otherwise proceed to [Step 26](#).
23. Locate the front and back floor mounting brackets from the optional floor mounting kit.
24. Using the cabinet mounting bolts from the kit, install the floor mounting brackets to the front and rear of the IAC-B with the angle facing outward.
25. Secure the cabinet to the floor with customer-supplied hardware.
26. Proceed to paragraph [4.5 Installing IAC-B External Power Wiring](#).


### 4.3 Installing the IAC-B Interface Connections


Use the procedures in the following paragraphs to connect the MBP, MIS, BIB and BIB Shunt Trip, RIB and Trapped Key Release Unit interface connections.

#### 4.3.1 MBP Auxiliary Contact Interface Connections



Due to the size and quantity of input and output power wiring, it is recommended to install the interface wiring first, then install the input and output power wiring.


- 
- 

**NOTE 1** MBP connection to TB1 is pre-wired, the wiring is bundled and ready to be routed to the UPS Static Switch.
  - 

**NOTE 2** MBP auxiliary contact control interface wiring is installed using the inter-cabinet wiring access pass-through.
- 

To install wiring:


1. Verify the UPS system is turned off and all power sources are removed.

- 
- 

**NOTE** Refer to the applicable Eaton 93PM-L UPS Installation and Operation manual listed in paragraph [1.8 For More Information](#), for detailed information on UPS operating procedures, wiring access, terminal locations, termination recommendations and building alarm terminal assignments.
- 

2. If not already opened, open the front door by lifting the latch from the bottom and turning to the right (counterclockwise) and swing the door open.
3. If not already removed, remove the screws securing the Upper, Middle and Lower internal safety shield panels and remove the panels to gain access to the terminals. Retain the hardware for later use.
4. **Pass-through Wiring:** Route MBP control wiring between the IAC-B interface terminals and the UPS CN8 Static Switch terminal using the inter-cabinet wiring access pass-through. See [Figure 17](#) for wiring access information, and [Figure 12](#) for interface terminal locations.
5. Connect the MBP control wiring to the UPS static switch terminals. See [Table 8](#) for terminal block wiring and termination recommendations. See [Table 9](#) for the IAC-B wiring information and terminal assignments.

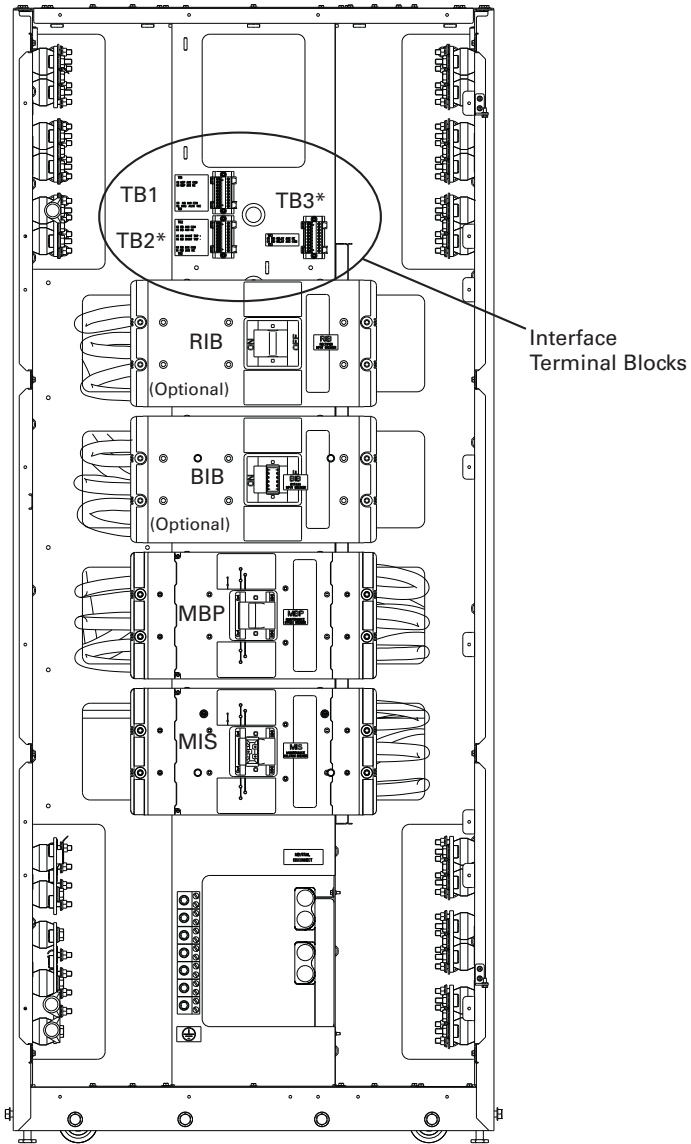
For a detailed view of the IAC-B terminals, see [Figure 15](#).

- 
- 

**NOTE** Refer to the applicable Eaton 93PM-L UPS Installation and Operation manual listed in paragraph [1.8 For More Information](#) for detailed information on the CN8 Static Switch Terminal location and terminal assignments.
- 

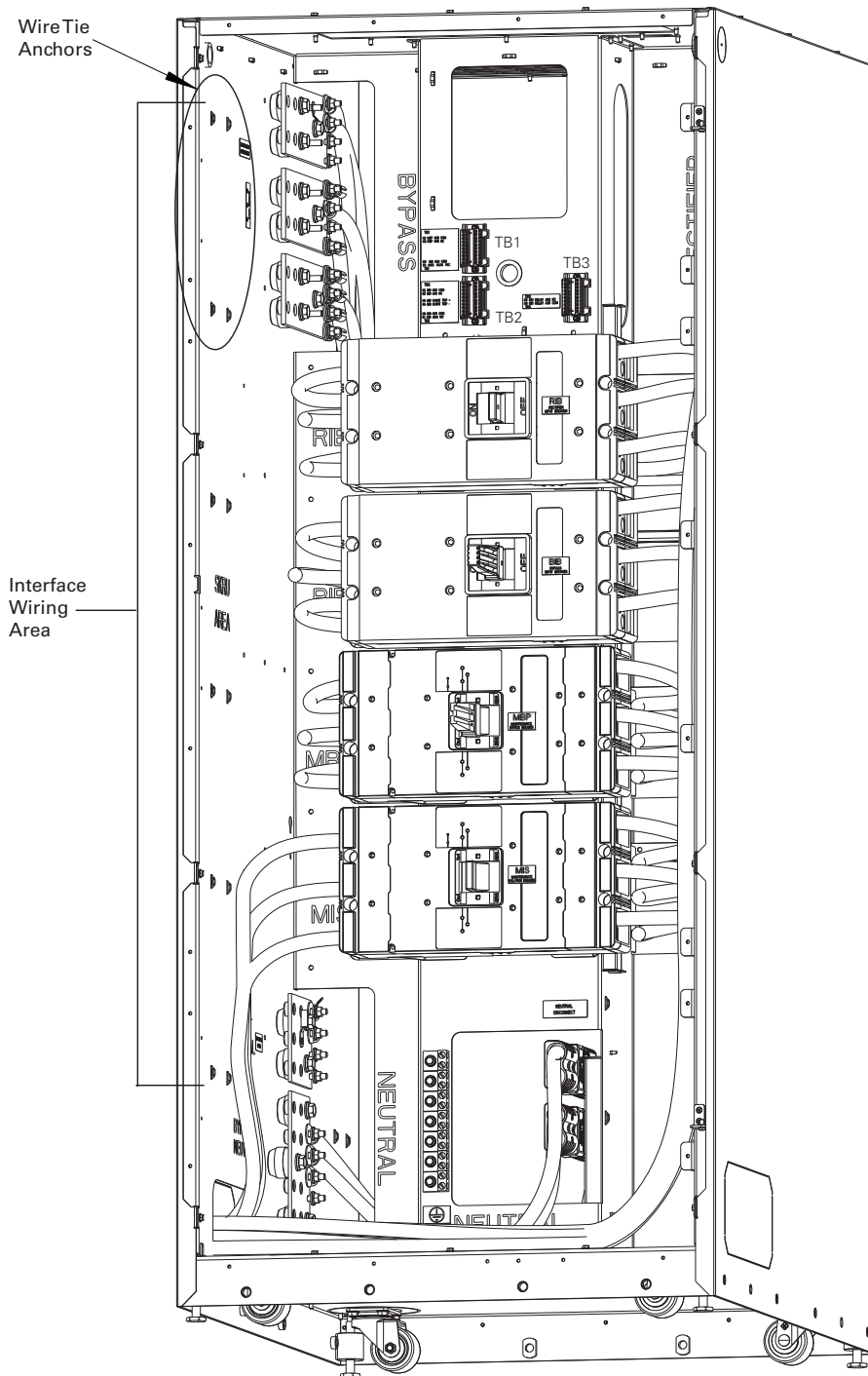
6. If wiring MIS interface connections proceed to paragraph [4.3.2 MIS Interface Connections](#); if wiring BIB interface connections proceed to paragraph [4.3.3 BIB Interface and Shunt Trip Connections \(if installed\)](#); if wiring RIB interface connections proceed to paragraph [4.3.4 RIB Interface Connections \(if installed\)](#); if wiring Trapped Key Interlock interface connections proceed to paragraph [4.3.5 Trapped Key Interface Connections \(if installed\)](#); otherwise proceed to [Step 7](#).
7. Reinstall all safety shield panels previously removed and secure with the retained hardware.
8. Close the outside door and secure the latch.
9. Proceed to paragraph [4.4 Two-Hole Barrel Lug Terminations to Bus Bar Installation](#).

Figure 12. 93PM-L IAC-B Interface Terminal Location



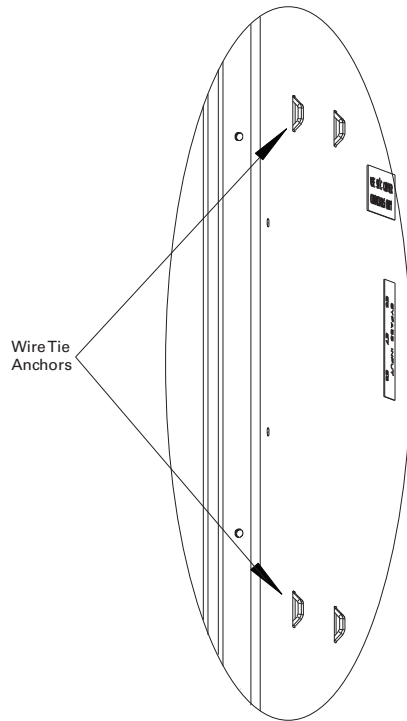
\* TB2 and TB3 are optional

**Figure 13. Interface Wiring Location**

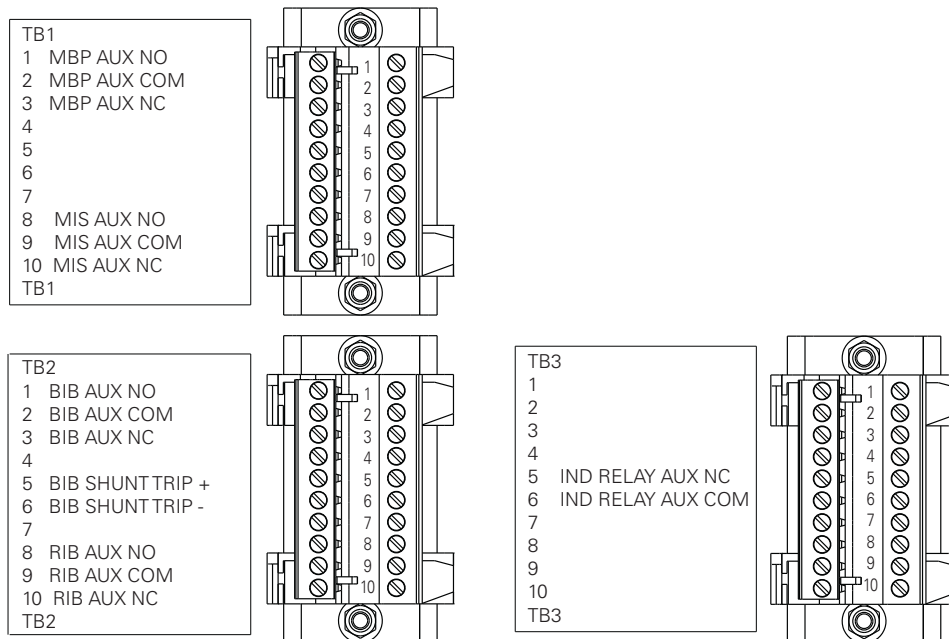


**NOTE:** Wire tie anchors are located on both the left and right sides and along the top back panel of the cabinet.

**Figure 14. Wire Tie Anchors**



**Figure 15. Interface Terminal Detail**



**Table 8. IAC-B All Interface Wiring Terminal Block Terminations**

Terminal Function	Size of Pressure Termination	Tightening Torque Nm (lb in)	Type Screw	Comments
Auxiliary Contacts	#26–#16	0.4 (3.5) - 0.8 (7.1)	Slotted	Use twisted-pair wires for each input and return or common. Strip wire insulation back 10 millimeters to wire terminal blocks.

**Table 9. IAC-B TB1 (MBP and MIS) Interface Terminals**

IAC-B Terminal	Name	Description
TB1–1	MBP Aux NO	Output: Normally Open (NO) contact used to indicate whether the MBP is closed and the UPS system is on maintenance bypass. Contacts are closed when the MBP is closed.
TB1–2	MBP Aux Common	
TB1–3	MBP Aux NC	
TB1–4	Not Used	
TB1–5	Not Used	
TB1–6	Not Used	
TB1–7	Not Used	
TB1–8	MIS Aux NO	Output: Normally Closed (NC) and normally-open (NO) contacts used to indicate whether the MIS is closed.
TB1–9	MIS Aux Common	
TB1–10	MIS Aux NC	

**NOTE** UPS building alarm signals are customer programmable. Customer interface wiring for the IAC-B MBP assumes that the UPS Building Alarm is programmed to monitor Normally Open (NO) contacts.  
Review the IAC-B Terminal Block 1 Wiring Diagram, see [Figure 29](#).



### 4.3.2 MIS Interface Connections


**NOTE**

If monitoring the MIS using the UPS programmable building alarms, route the wiring through the inter-cabinet pass-through; otherwise the interface wiring is routed through conduit to the customer's monitoring station.

1. Verify the UPS system is turned off and all power sources are removed.


**NOTE**

Refer to the applicable Eaton 93PM-L UPS Installation and Operation manual listed in paragraph [1.8 For More Information](#), for detailed information on UPS operating procedures, wiring access, terminal locations, termination recommendations and building alarm terminal assignments.

2. If not already opened, open the front door by lifting the latch from the bottom and turning to the right (counterclockwise) and swing the door open.
3. If not already removed, remove the screws securing the Upper, Middle and Lower internal safety shield panels and remove the panels to gain access to the terminals. Retain the hardware for later use.
4. If wiring the IAC-B interface terminal to monitor the MIS via the UPS programmable building alarms, use the inter-cabinet pass-through, proceed to [Step 11](#). If wiring the IAC-B interface terminal to monitor the MIS via a customer monitoring station using the top entry access, proceed to [Step 8](#); if wiring using the bottom entry access, proceed to [Step 5](#).
5. **Bottom Entry Wiring:** Remove the bottom interface conduit plate (see [Figure 18](#)) from the inside bottom of the IAC-B. Identify all conduit requirements and mark their location. Drill and punch all conduit holes in the bottom interface conduit plate prior to mounting on the IAC-B. Install the conduit plate and install all conduit runs into the plate. Pull the wiring through the conduit into the wiring areas.
6. Route the MIS interface wiring between the IAC-B interface terminals and the customer's monitoring station using the bottom entry interface conduit landing plates on the IAC-B (see [Figure 13](#)). Route the wiring along the left side of the cabinet to the terminals. Secure the wiring to the wire tie anchors provided (see [Figure 14](#)) using Zip ties.
7. Proceed to [Step 13](#).
8. **Top Entry Wiring:** Remove the top interface conduit plate (see [Figure 18](#)) from the top of the IAC-B. Identify all conduit requirements and mark their location. Drill and punch all conduit holes in the bottom interface conduit plate prior to mounting on the IAC-B. Install the conduit plate and install all conduit runs into the plate. Pull the wiring through the conduit into the wiring areas.
9. Route the MIS interface wiring between the IAC-B interface terminals and the customer's monitoring station using the top entry interface conduit landing plates on the IAC-B (see [Figure 13](#)). Route the wiring along the inside top of the cabinet to the terminals. Secure the wiring to the wire tie anchors provided (see [Figure 14](#)) using Zip ties.
10. Proceed to [Step 13](#).
11. **Pass-through Wiring:** Route the MIS interface wiring between the IAC-B interface terminals and the UPS interface terminals using the inter-cabinet wiring access pass-through. Route the wiring along the inside top of the cabinet to the terminals. Secure the wiring to the wire tie anchors provided (see [Figure 14](#)) using Zip ties.


**NOTE**

Refer to the applicable Eaton 93PM-L UPS Installation and Operation manual listed in paragraph **1.8 For More Information** for detailed information on the UPS interface terminal location and terminal assignments.

12. Connect the MIS interface wiring to the UPS terminals. Proceed to [Step 14](#).

13. Connect the MIS interface wiring to the IAC-B and customer's monitoring station. See [Table 8](#) for terminal block wiring and termination recommendations. See [Table 9](#) for the IAC-B wiring information and terminal assignments.

For a detailed view of the IAC-B terminals, see [Figure 15](#).

14. If wiring BIB interface connections proceed to paragraph [4.3.3 BIB Interface and Shunt Trip Connections \(if installed\)](#); if wiring RIB interface connections proceed to paragraph [4.3.4 RIB Interface Connections \(if installed\)](#); if wiring Trapped Key Interlock interface connections proceed to paragraph [4.3.5 Trapped Key Interface Connections \(if installed\)](#); otherwise proceed to [Step 15](#).
15. Reinstall all safety shield panels previously removed and secure with the retained hardware.
16. Close the outside door and secure the latch.
17. Proceed to paragraph [4.4 Two-Hole Barrel Lug Terminations to Bus Bar Installation](#).

### 4.3.3 BIB Interface and Shunt Trip Connections (if installed)

---

**NOTE 1** The BIB is optional equipment.



**NOTE 2** BIB connection to TB2 is pre-wired, the wiring is bundled and ready to be routed to the UPS terminal.

**NOTE 3** BIB interface wiring is installed using the inter-cabinet wiring access pass-through.

---

1. Verify the UPS system is turned off and all power sources are removed.



**NOTE** Refer to the applicable Eaton 93PM-L UPS Installation and Operation manual listed in paragraph [1.8 For More Information](#) for detailed information on UPS operating procedures, wiring access, terminal locations, termination recommendations and building alarm terminal assignments.

---

2. If not already opened, open the front door by lifting the latch from the bottom and turning to the right (counterclockwise) and swing the door open.
3. If not already removed, remove the screws securing the Upper, Middle and Lower internal safety shield panels and remove the panels to gain access to the terminals. Retain the hardware for later use.
4. **Pass-through Wiring:** Route BIB and BIB Shunt Trip (if installed) interface wiring between the IAC-B interface terminals and the UPS CN8 Static Switch terminals using the inter-cabinet wiring access pass-through. See [Figure 17](#) for wiring access information, and [Figure 12](#) for interface terminal locations.
5. Connect the BIB and BIB Shunt Trip (if installed) interface wiring to the UPS CN8 Static Switch terminals. See [Table 8](#) for terminal block wiring and termination recommendations. See [Table 10](#) for the IAC-B wiring information and terminal assignments.



**NOTE** Refer to the applicable Eaton 93PM-L UPS Installation and Operation manual listed in paragraph [1.8 For More Information](#) for detailed information on the CN8 Static Switch Terminal location and terminal assignments.

---

For a detailed view of the IAC-B terminals see [Figure 15](#).

6. If wiring RIB interface connections proceed to paragraph [4.3.4 RIB Interface Connections \(if installed\)](#); if wiring Trapped Key Interlock interface connections proceed to paragraph [4.3.5 Trapped Key Interface Connections \(if installed\)](#); otherwise proceed to [Step 7](#).
7. Reinstall all safety shield panels previously removed and secure with the retained hardware.
8. Close the outside door and secure the latch.

9. Proceed to paragraph [4.4 Two-Hole Barrel Lug Terminations to Bus Bar Installation](#).

**Table 10. IAC-B TB2 (BIB and RIB) Interface Terminals**

IAC-B Terminal	Name	Description
TB2-1	BIB Aux NO	Output: Normally Open (NO) contact used to indicate whether the MBP is closed and the UPS system is on maintenance bypass. Contacts are closed when the MBP is closed.
TB2-2	BIB Aux Common	
TB2-3	BIB Aux NC	
TB2-4	Not Used	
TB2-5	BIB Shunt Trip +	Output: Contacts used to open bypass breaker or disconnect
TB2-6	BIB Shunt Trip –	
TB2-7	Not Used	
TB2-8	RIB Aux NO	Output: Normally Closed (NC) and normally-open (NO) contacts used to indicate whether the MIS is closed.
TB2-9	RIB Aux Common	
TB2-10	RIB Aux NC	

**NOTE** UPS building alarm signals are customer programmable.  
Review the IAC-B Terminal Block 2 Wiring Diagram, see [Figure 30](#).

#### 4.3.4 RIB Interface Connections (if installed)

**NOTE 1** RIB is optional equipment.



**NOTE 2** If monitoring the RIB, other than through the UPS programmable building alarms, route the wiring through the inter-cabinet pass-through; otherwise the interface wiring is routed through conduit to the customer's monitoring station.

1. Verify the UPS system is turned off and all power sources are removed.



**NOTE** Refer to the applicable Eaton 93PM-L UPS Installation and Operation manual listed in paragraph [1.8 For More Information](#), for detailed information on UPS operating procedures, wiring access, terminal locations, termination recommendations and building alarm terminal assignments.

2. If not already opened, open the front door by lifting the latch from the bottom and turning to the right (counterclockwise) and swing the door open.
3. If not already removed, remove the screws securing the Upper, Middle and Lower internal safety shield panels and remove the panels to gain access to the terminals. Retain the hardware for later use.
4. If wiring the IAC-B interface terminal to monitor the RIB via the UPS programmable building alarms, use the inter-cabinet pass-through, proceed to Step 11. If wiring the IAC-B interface terminal to monitor the MIS via a customer monitoring station using the top entry access, proceed to [Step 8](#); if wiring using the bottom entry access, proceed to [Step 5](#).
5. **Bottom Entry Wiring:** Remove the bottom interface conduit plate (see [Figure 18](#)) from the inside bottom of the IAC-B. Identify all conduit requirements and mark their location. Drill and punch all conduit holes in the bottom interface conduit plate prior to mounting on the IAC-B. Install the conduit plate and install all conduit runs into the plate. Pull the wiring through the conduit into the wiring areas.

6. Route the RIB (if installed) interface wiring between the IAC-B interface terminals and the customer monitoring station using the bottom entry interface conduit landing plates on the IAC-B (see [Figure 13](#)) and the UPS. Route the wiring along the left side of the cabinet to the terminals. Secure the wiring to the wire tie anchors provided (see [Figure 14](#)) using Zip ties.
7. Proceed to [Step 13](#).
8. **Top Entry Wiring:** Remove the top interface conduit plate (see [Figure 18](#)) from the top of the IAC-B. Identify all conduit requirements and mark their location. Drill and punch all conduit holes in the bottom interface conduit plate prior to mounting on the IAC-B. Install the conduit plate and install all conduit runs into the plate. Pull the wiring through the conduit into the wiring areas.
9. Route the RIB (if installed) interface wiring between the IAC-B interface terminals and the customer monitoring station using the top entry interface conduit landing plates on the IAC-B (see [Figure 13](#)) and the UPS. Route the wiring along the inside top of the cabinet to the terminals. Secure the wiring to the wire tie anchors provided (see [Figure 14](#)) using Zip ties.
10. Proceed to [Step 13](#).
11. **Pass-through Wiring:** Route the RIB interface wiring between the IAC-B interface terminals and the UPS interface terminals using the inter-cabinet wiring access pass-through. Route the wiring along the inside top of the cabinet to the terminals. Secure the wiring to the wire tie anchors provided (see [Figure 14](#)) using Zip ties.
12. Connect the RIB interface wiring to the UPS terminals. See [Table 8](#) for terminal block wiring and termination recommendations. See [Table 10](#) for the IAC-B wiring information and terminal assignments.

**NOTE**

Refer to the applicable Eaton 93PM-L UPS Installation and Operation manual listed in paragraph **1.8 For More Information** for detailed information on the UPS interface terminal location and terminal assignments.

---

Proceed to [Step 14](#).

13. Connect the RIB interface wiring to the customer monitoring station.  
For a detailed view of the IAC-B terminals see [Figure 15](#).
14. If wiring Trapped Key Interlock interface connections proceed to paragraph [4.3.5 Trapped Key Interface Connections \(if installed\)](#); otherwise proceed to [Step 15](#).
15. Reinstall all safety shield panels previously removed and secure with the retained hardware.
16. Close the outside door and secure the latch.
17. Proceed to paragraph [4.4 Two-Hole Barrel Lug Terminations to Bus Bar Installation](#).

### 4.3.5 Trapped Key Interface Connections (if installed)

---

**NOTE 1**

The Trapped Key interlock system is optional equipment.

**NOTE 2**

Trapped Key connection to TB3 is pre-wired, the wiring is bundled and ready to be routed to the UPS terminal.

**NOTE 3**

Trapped Key control wiring is installed using the inter-cabinet wiring access pass-through.

**NOTE 4**


Use wire rated for 600V and Class 2 wiring methods.

---

To install wiring:

1. Verify the UPS system is turned off and all power sources are removed.

---

**NOTE**  Refer to the applicable Eaton 93PM-L UPS Installation and Operation manual listed in paragraph [1.8 For More Information](#) for detailed information on UPS operating procedures, wiring access, terminal locations, termination recommendations and building alarm terminal assignments.

---

2. If not already opened, open the front door by lifting the latch from the bottom and turning to the right (counterclockwise) and swing the door open.
3. If not already removed, remove the screws securing the Upper, Middle and Lower internal safety shield panels and remove the panels to gain access to the terminals. Retain the hardware for later use.
4. **Pass-through Wiring:** Route Trapped Key control wiring between the IAC-B TB3 interface terminal and the UPS interface terminals using the inter-cabinet wiring access pass-through. See [Figure 17](#) for wiring access information, and [Figure 12](#) for interface terminal locations.
5. Connect the Trapped Key control wiring to the UPS terminals. See [Table 8](#) for terminal block wiring and termination recommendations. See [Table 11](#) for the IAC-B wiring information and terminal assignments.  
For a detailed view of the IAC-B terminals see [Figure 15](#).
6. Reinstall all safety shield panels previously removed and secure with the retained hardware.
7. Close the outside door and secure the latch.
8. Proceed to paragraph [4.4 Two-Hole Barrel Lug Terminations to Bus Bar Installation](#).

**Table 11. IAC-B TB3 (Trapped Key) Interface Terminals**

IAC-B Terminal	Name	Description
TB3-1	Not Used	
TB3-2	Not Used	
TB3-3	Not Used	
TB3-4	Not Used	
TB3-5	Ind Relay Aux NC	Used to provide control power to the Trapped Key when the UPS is on bypass allowing maintenance bypass transfer. IRC relay K4 contacts are closed when the UPS is on bypass.
TB3-6	Ind Relay Aux COM	
TB3-7	Not Used	
TB3-8	Not Used	
TB3-9	Not Used	
TB3-10	Not Used	


**NOTE** Review the IAC-B Terminal Block 3 Wiring Diagram, see [Figure 31](#).

---

#### 4.4 Two-Hole Barrel Lug Terminations to Bus Bar Installation

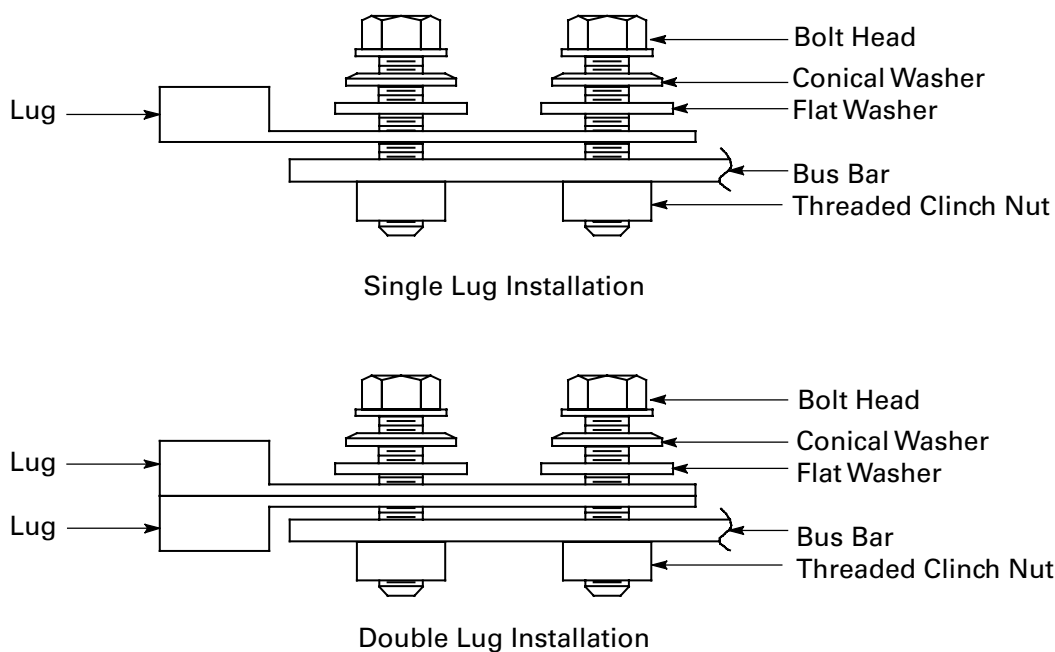
Paragraphs [4.5.1 IAC-B with a 2, 3 or 4-Breaker Single Feed Configurations](#) and [4.5.2 IAC-B with a 4-Breaker Dual Feed Configuration \(MBP, MIS, BIB and RIB\)](#) detail processes that require connecting input and output wiring using 2-hole barrel lugs. See [Figure 16](#) for the hardware sequence when installing the lugs to the bus bars. Tighten the bolt to the torque value listed in [Table 5](#).

---

**NOTE**  Conical washers are special purpose washers that look similar to flat washers, except for a slight conical shape. When installing conical washers, the top of the dome should be next to the bolt head and the base of the washer should be against the flat washer.

---

**Figure 16. Typical Bus Bar Barrel Lug Mounting – Hardware Assembly Sequence**



## 4.5 Installing IAC-B External Power Wiring



### IMPORTANT

Due to the size and quantity of input and output power wiring, it is recommended to install the interface wiring first, then install the input and output power wiring.

**NOTE 1** Power wiring from the UPS is routed through the side bottom of the IAC-B and UPS for line-up-and-match configurations using the pass-through wiring procedures. Input and output power wiring to the IAC-B is routed through the top or bottom of the cabinet using conduit.

**NOTE 2** Line-up-and-match UPS phase power wiring is factory supplied.



**NOTE 3** Two-hole barrel lugs are installed on the ends of the factory supplied cable harnesses. Do not shorten or cut factory supplied wiring.

**NOTE 4** Remove the IAC-B conduit landing plates to drill or punch conduit holes in the conduit plates (see [Figure 18](#)).

**NOTE 5** Refer to the applicable Eaton 93PM-L UPS Installation and Operation manual, listed in paragraph [1.8 For More Information](#), for UPS installation procedures.

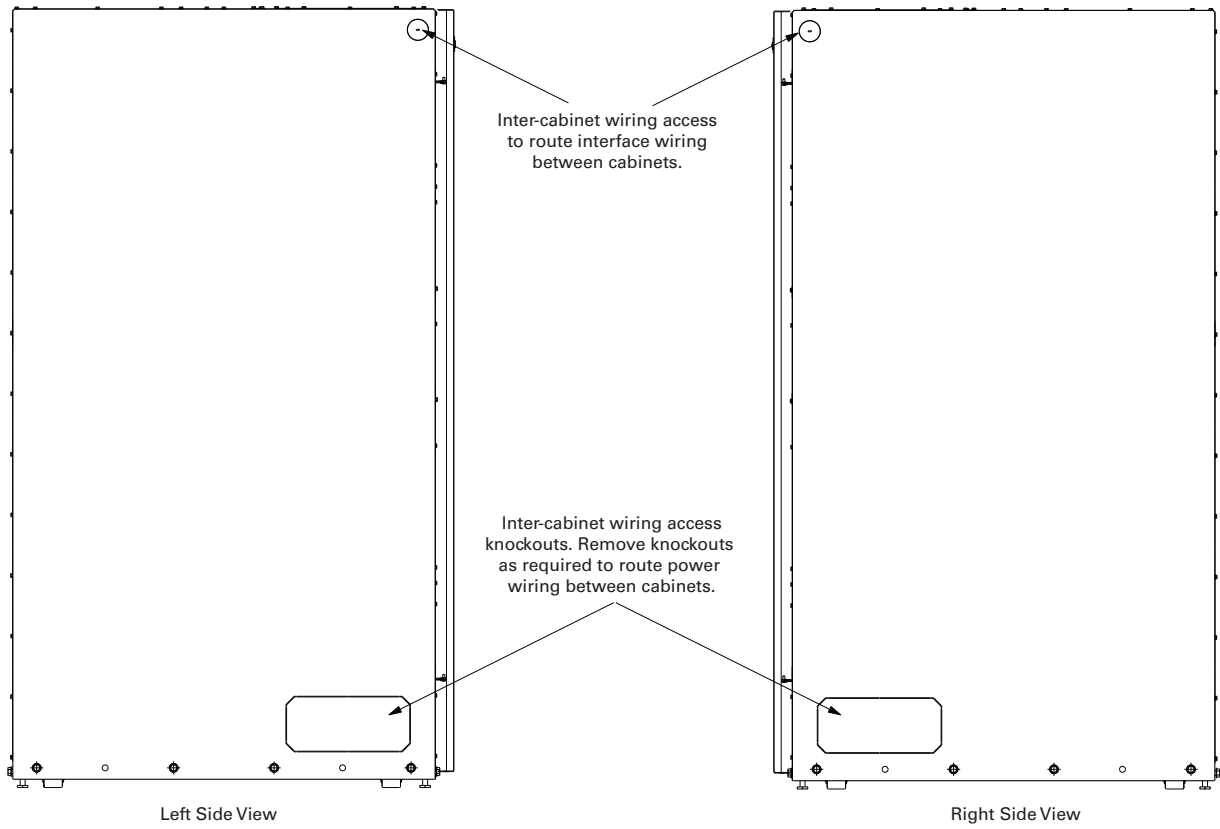
1. Verify the UPS system is turned off and all power sources are removed. Refer to the applicable Eaton 93PM-L UPS Installation and Operation manual, listed in paragraph [1.8 For More Information](#), for UPS operating procedures.
2. Open the front door by lifting the latch from the bottom and turning to the right (counterclockwise) and swing the door open.
3. Remove the screws securing the Upper, Middle and Lower internal safety shield panels and remove the panels to gain access to the input, neutral, output and ground terminals. Retain the hardware for later use.



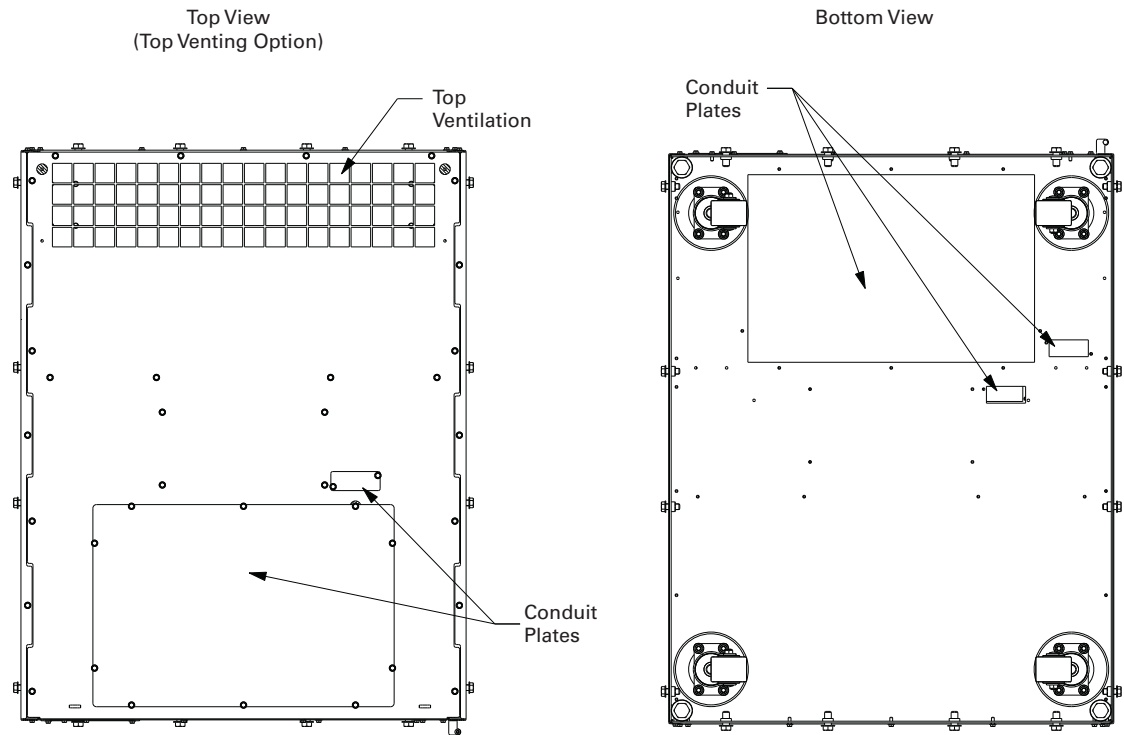
**NOTE** If IAC-B comes with the Trapped Key option, remove the Trapped Key assembly and disconnect the Trapped Key interface cabling. Save hardware for later use.

4. If installing a 2, 3 or 4-Breaker Single Feed IAC-B, proceed to paragraph [4.5.1 IAC-B with a 2, 3 or 4-Breaker Single Feed Configurations](#); if installing a 4-Breaker Dual Feed IAC-B proceed to paragraph [4.5.2 IAC-B with a 4-Breaker Dual Feed Configuration \(MBP, MIS, BIB and RIB\)](#).

**Figure 17. Line-Up-and-Match Wiring Access Locations**





**Figure 18. Top and Bottom Conduit Landing Wire Entry Locations**

#### 4.5.1 IAC-B with a 2, 3 or 4-Breaker Single Feed Configurations



#### IMPORTANT

- Due to the size and quantity of cables, top entry wiring to the IAC-B input terminals is recommended.
- “High strand count extra flexible” copper wire is recommended.

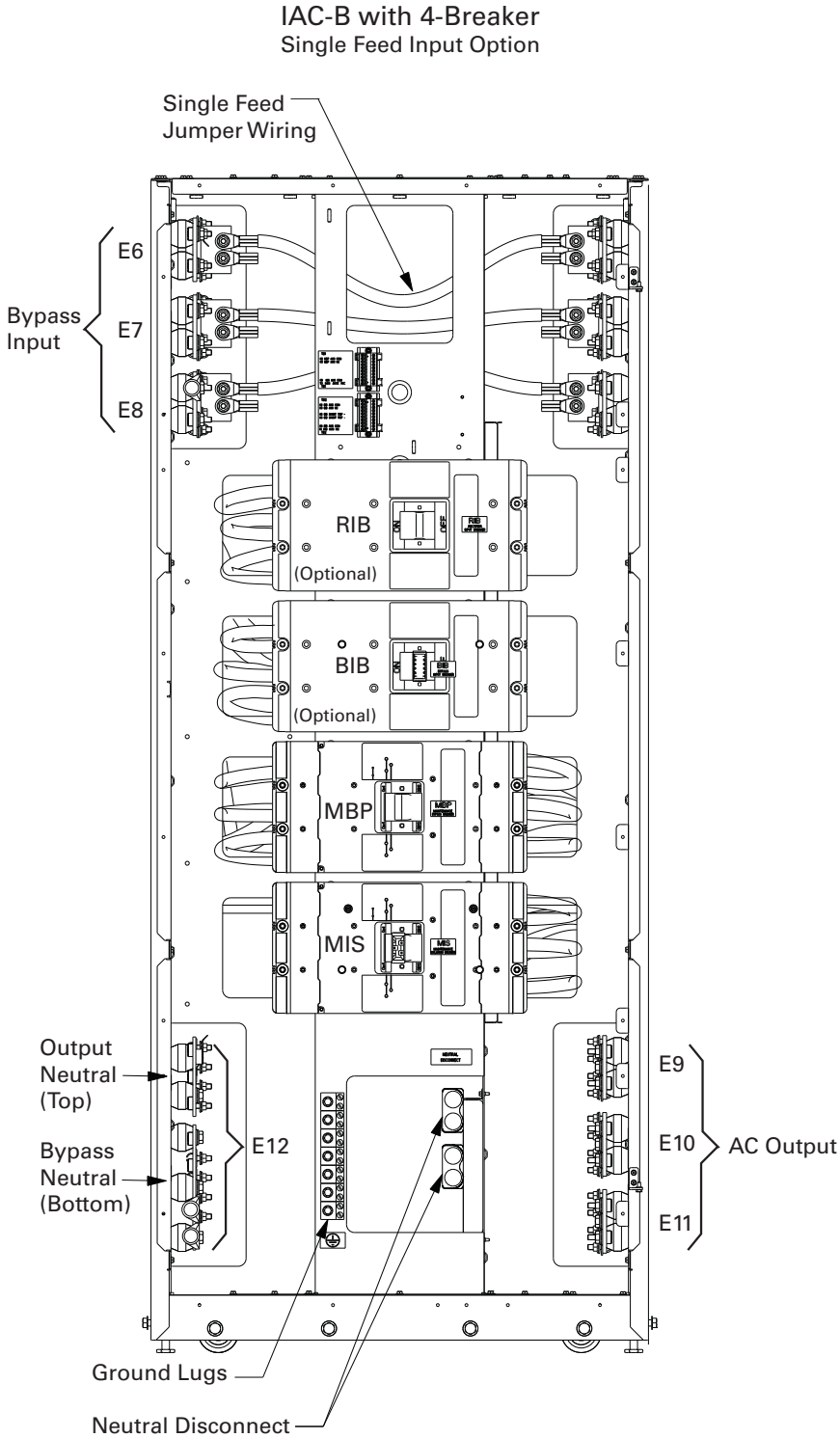
If wiring the IAC-B through the Top Entry Wiring Conduits go to [Step 1](#); otherwise go to [Step 10](#).

1. **Top Entry Wiring** Remove the top conduit plate (see [Figure 18](#)) from the IAC-B. Identify all input and output conduit recommendations and mark their location. Drill and punch all conduit holes in the conduit plate prior to mounting on the IAC-B. Reinstall the conduit plate. Install conduit between the IAC-B and the bypass input source, and between the IAC-B and the critical load. Pull the wiring through the conduit into the wiring area.
2. Route the bypass input cables (phase A, B, and C) through the top of the IAC-B to the bypass input terminals (E6, E7, and E8) in the upper cabinet area. See [Figure 19](#) for IAC-B terminal locations. See paragraph [3.2.3 IAC-B Power Wiring Preparation](#), [Table 5](#) for IAC-B wiring and termination recommendations.
3. Route the maintenance ground and bypass neutral wire through the top of the IAC-B to the ground and neutral terminals in the lower cabinet area.

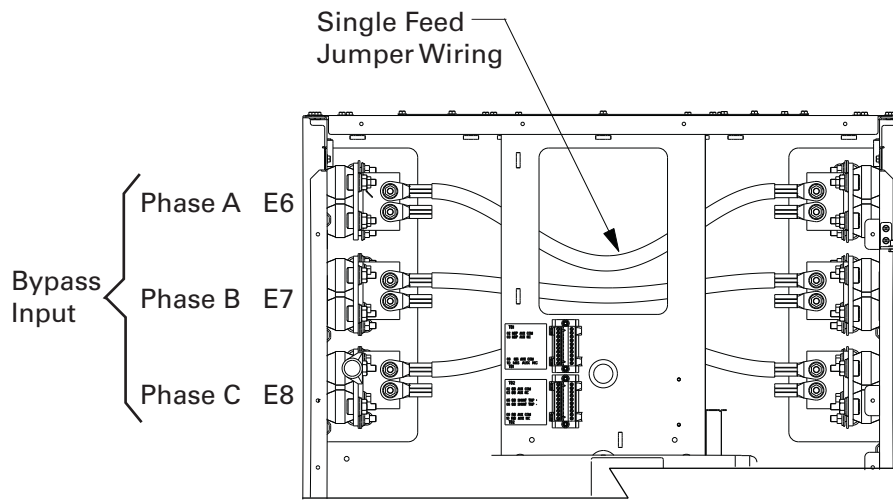
## Installing IAC-B External Power Wiring

4. Route the output cables (phase A, B, and C), ground and neutral wires from the IAC-B output terminals (E9, E10 and E11) through the top of the IAC-B to the critical load.
5. Secure the wiring to the wire tie anchors provided (see [Figure 14](#)) using Zip ties.
6. Using hardware from the external wiring terminal hardware kit, connect ground and bypass neutral wiring from the utility source to the IAC-B ground and bypass neutral terminals (E12) in the lower cabinet area. See [Figure 21](#) for terminal connection detail.
7. Using hardware from the external wiring terminal hardware kit, connect phase A, B, and C, input power wiring from the utility source to the IAC-B bypass input terminals (E6, E7, and E8) in the upper cabinet area. See [Figure 20](#) for terminal connection detail.
8. Using hardware from the external wiring terminal hardware kit, connect the phase A, B, and C, ground and output neutral (E12) power wiring from the IAC-B output terminals (E9, E10 and E11) in the lower cabinet area to the critical load.
9. Continue to .
10. **Bottom Entry Wiring** Remove the bottom conduit plate (see [Figure 18](#)) from the IAC-B. Identify all input and output conduit recommendations and mark their location. Drill and punch all conduit holes in the conduit plate prior to mounting on the IAC-B. Reinstall the conduit plate. Install conduit between the IAC-B and the bypass input source, and between the IAC-B and the critical load. Pull the wiring through the conduit into the wiring area.
11. Route the bypass input cables (phase A, B, and C) through the bottom of the IAC-B to the bypass input terminals (E6, E7, and E8) in the upper cabinet area. See [Figure 19](#) for IAC-B terminal locations. See paragraph [3.2.3 IAC-B Power Wiring Preparation](#), [Table 5](#) for IAC-B wiring and termination recommendations.
12. Route the maintenance ground and bypass neutral wire through the bottom of the IAC-B to the ground and bypass neutral terminals (E12) in the lower cabinet area.
13. Route the output cables (phase A, B, and C), ground and neutral wires from the IAC-B output terminals (E9, E10 and E11) through the bottom of the IAC-B to the critical load.
14. Secure the wiring to the wire tie anchors provided (see [Figure 14](#)) using Zip ties.
15. Using hardware from the external wiring terminal hardware kit, connect ground and bypass neutral wiring from the utility source to the IAC-B ground and bypass neutral terminals (E12) in the lower cabinet area. See [Figure 21](#) for terminal connection.
16. Using hardware from the external wiring terminal hardware kit, connect phase A, B, and C, input power wiring from the utility source to the IAC-B bypass input terminals (E6, E7 and E8) in the upper cabinet area. See [Figure 20](#) for terminal connection detail.
17. Using hardware from the external wiring terminal hardware kit, connect the phase A, B, and C, ground and output neutral (E12) power wiring from the IAC-B output terminals (E9, E10, and E11) in the lower cabinet area to the critical load.
18. Continue to paragraph [4.5.3 UPS to IAC-B Breaker Wiring](#).

Figure 19. IAC-B Single Feed Terminal Locations

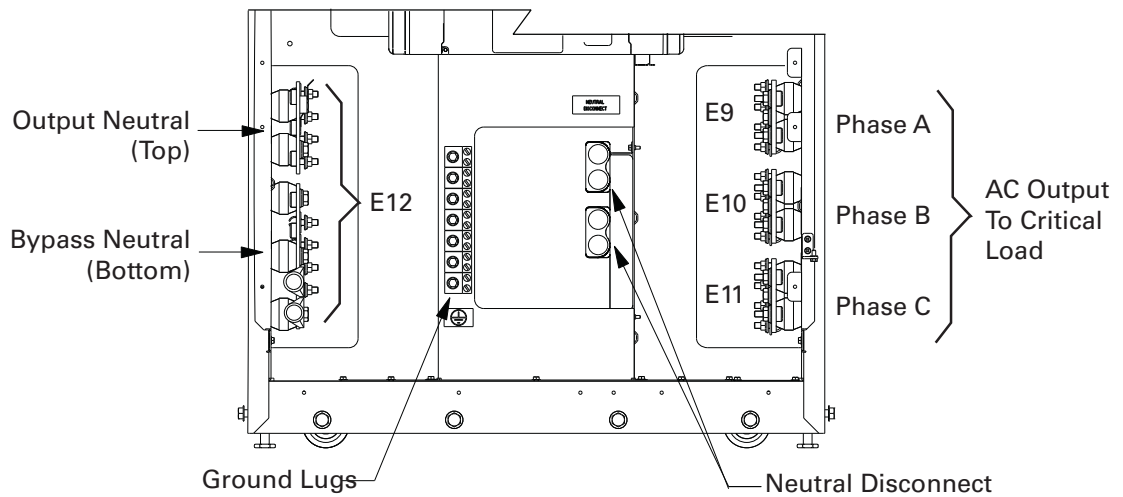


**Figure 20. IAC-B Single Feed Upper Cabinet Terminal Detail**



Upper Cabinet Area View of IAC-B  
Single Feed Input Option

**Figure 21. IAC-B Lower Cabinet Terminal Detail**



Lower Cabinet Area View of IAC-B

#### 4.5.2 IAC-B with a 4–Breaker Dual Feed Configuration (MBP, MIS, BIB and RIB)



#### IMPORTANT

- Due to the size and quantity of cables, top entry wiring to the IAC-B input terminals is recommended.
- “High strand count extra flexible” copper wire is recommended.

If wiring the IAC-B through the Top Entry Wiring Conduits go to Step [Step 1](#); otherwise go to [Step 13](#).

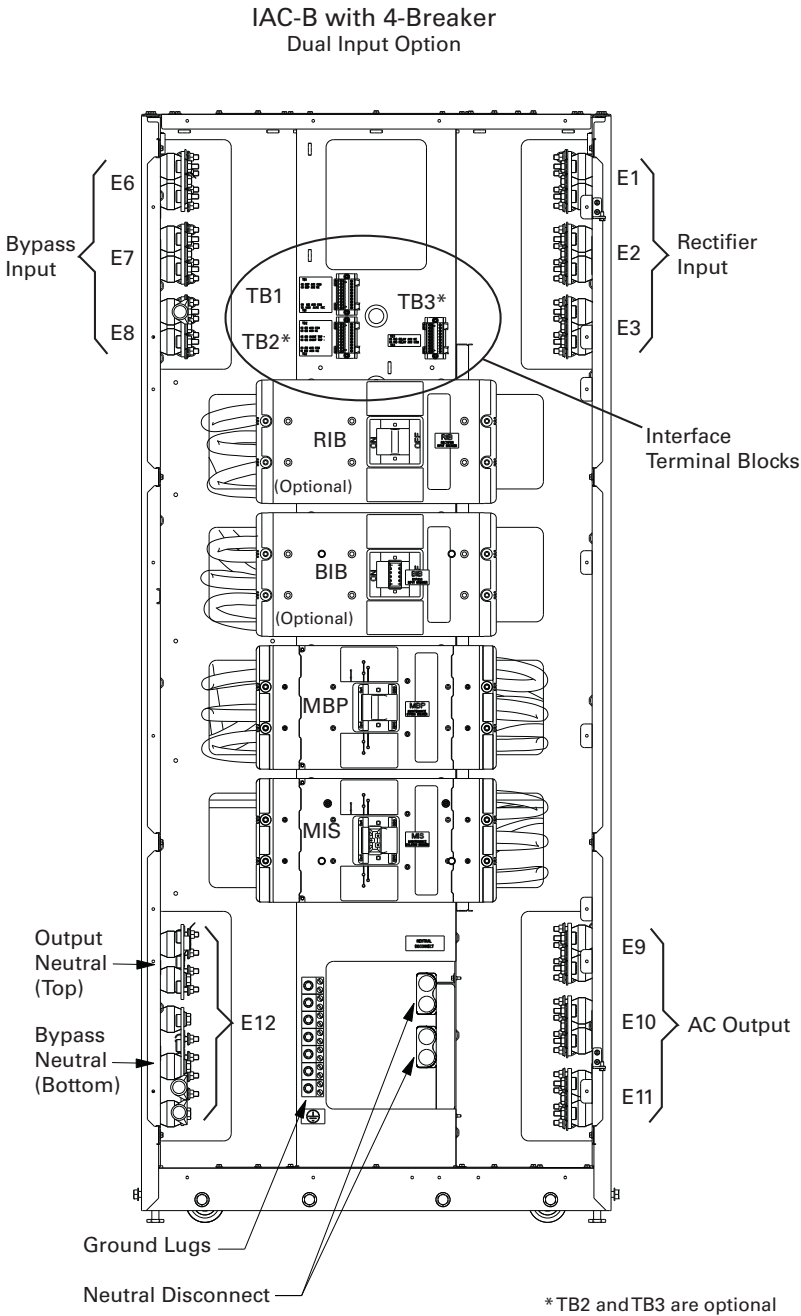
To install wiring to terminal connections:

1. **Top Entry Wiring** Remove the top conduit plate (see [Figure 18](#)) from the IAC-B. Identify all input and output conduit recommendations and mark their location. Drill and punch all conduit holes in the conduit plate prior to mounting on the IAC-B. Reinstall the conduit plate. Install conduit between the IAC-B and the bypass input source, the rectifier input source, between the IAC-B and the UPS output, and between the IAC-B and the critical load. Pull the wiring through the conduit into the wiring area.
2. Route the bypass input cables (phase A, B, and C) through the top of the IAC-B to the bypass input terminals (E6, E7, and E8) in the upper cabinet area. See [Figure 22](#) for IAC-B terminal locations. See paragraph [3.2.3 IAC-B Power Wiring Preparation, Table 5](#) for IAC-B wiring and termination recommendations.
3. Route the maintenance ground and bypass neutral wire through the top of the IAC-B to the ground and neutral terminals in the lower cabinet area.
4. Route the rectifier input cables (phase A, B, and C), wire through the top of the IAC-B to the rectifier input terminals (E1, E2, and E3) in the upper cabinet area.
5. Route the rectifier Ground wire through the top of the IAC-B to the Ground terminals in the lower cabinet area.
6. Route the output cables (phase A, B, and C), ground and neutral wires from the IAC-B output terminals (E9, E10 and E11) through the top of the IAC-B to the critical load.
7. Secure the wiring to the wire tie anchors provided (see [Figure 14](#)) using Zip ties.
8. Using hardware from the external wiring terminal hardware kit, connect ground and bypass neutral wiring from the utility source to the IAC-B ground and bypass neutral terminals (E12) in the lower cabinet area. See [Figure 21](#) for terminal connection .
9. Using hardware from the external wiring terminal hardware kit, connect phase A, B, and C, input power wiring from the utility source to the IAC-B bypass input terminals (E6, E7, and E8) in the upper cabinet area. See [Figure 20](#) for terminal connection .
10. Using hardware from the external wiring terminal hardware kit, connect phase A, B, and C, input power wiring from the utility source to the IAC-B rectifier input terminals (E1, E2, and E3) in the upper cabinet area.
11. Using hardware from the external wiring terminal hardware kit, connect the phase A, B, and C, ground and output neutral (E12) power wiring from the IAC-B output terminals (E9, E10 and E11) in the lower cabinet area to the critical load.
12. Continue to paragraph [4.5.3 UPS to IAC-B Breaker Wiring](#).
13. **Bottom Entry Wiring** Remove the bottom conduit plate (see [Figure 18](#)) from the IAC-B. Identify all input and output conduit recommendations and mark their location. Drill and punch all conduit holes in the conduit plate prior to mounting on the IAC-B. Reinstall the conduit plate. Install conduit between the IAC-B and the bypass input source, the rectifier input source, between the IAC-B and the UPS output, and between the IAC-B and the critical load. Pull the wiring through the conduit into the wiring area.

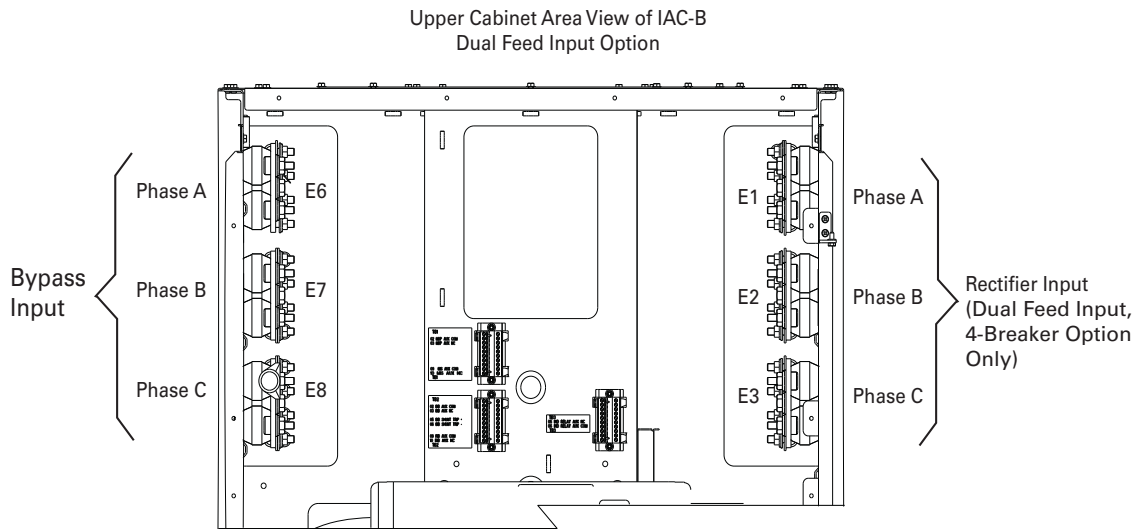
## Installing IAC-B External Power Wiring

14. Route the bypass input cables (phase A, B, and C) through the bottom of the IAC-B to the bypass input terminals (E6, E7, and E8) in the upper cabinet area. See [Figure 22](#) for IAC-B terminal locations. See paragraph [3.2.3 IAC-B Power Wiring Preparation](#), [Table 5](#) for IAC-B wiring and termination recommendations.
15. Route the maintenance ground and bypass neutral wire through the bottom of the IAC-B to the ground and neutral terminals in the lower cabinet area.
16. Route the rectifier input cables (phase A, B, and C), wire through the bottom of the IAC-B to the rectifier input terminals (E1, E2, and E3) in the upper cabinet area.
17. Route the rectifier Ground wire through the bottom of the IAC-B to the Ground terminals in the lower cabinet area.
18. Route the output cables (phase A, B, and C), ground and neutral wires from the IAC-B output terminals (E9, E10 and E11) through the bottom of the IAC-B to the critical load.
19. Secure the wiring to the wire tie anchors provided (see [Figure 14](#)) using Zip ties.
20. Using hardware from the external wiring terminal hardware kit, connect ground and bypass neutral wiring from the utility source to the IAC-B ground and bypass neutral terminals (E12) in the lower cabinet area. See [Figure 21](#) for terminal connection detail.
21. Using hardware from the external wiring terminal hardware kit, connect phase A, B, and C, input power wiring from the utility source to the IAC-B bypass input terminals (E6, E7, and E8) in the upper cabinet area. See [Figure 23](#) for terminal connection detail.
22. Using hardware from the external wiring terminal hardware kit, connect phase A, B, and C, input power wiring from the utility source to the IAC-B rectifier input terminals (E1, E2, and E3) in the upper cabinet area.
23. Using hardware from the external wiring terminal hardware kit, connect the phase A, B, and C, ground and output neutral (E12) power wiring from the IAC-B output terminals (E9, E10 and E11) in the lower cabinet area to the critical load.
24. Continue to paragraph [4.5.3 UPS to IAC-B Breaker Wiring](#).

Figure 22. IAC-B Dual Feed Terminal Locations



**Figure 23. IAC-B Dual Feed Upper Cabinet Terminal Detail**



#### 4.5.3 UPS to IAC-B Breaker Wiring

To install wiring to terminal connections:

- 
- NOTE 1** The various cabling for the wiring between the UPS and the IAC-B breakers is packaged and shipped separately on its own pallet.
  - NOTE 2** The BIB, RIB, Output and Neutral wiring provided is based on IAC-B configuration ordered.
  - NOTE 3** Ground wiring is customer supplied.
- 

1. **Pass-through Wiring.** Locate and remove the phase power cable harness labeled UPS OUTPUT.

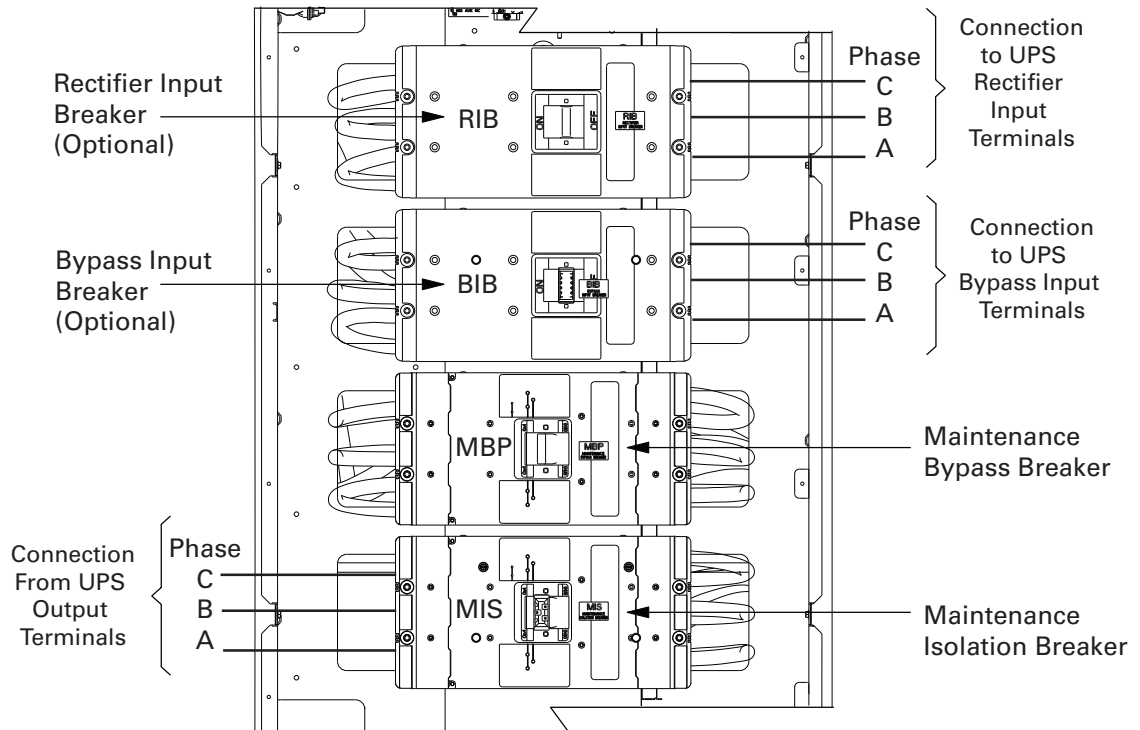
- 
- NOTE** UPS OUTPUT power cables have two-hole barrel lugs installed on the ends. Route the cable ends marked E9, E10, E11 to the UPS output terminals.
- 

2. **MIS Breaker:** Route the UPS OUTPUT to MIS input cables (phase A, B, and C) from the UPS cabinet through the bottom UPS and IAC-B inter-cabinet wiring access pass-through to the IAC-B MIS breaker input terminals. See [Figure 17](#) for IAC-B wiring access information and [Figure 24](#) for IAC-B terminal locations. See paragraph [3.2.3 IAC-B Power Wiring Preparation, Table 5](#) for IAC-B wiring and termination recommendations. Refer to the applicable Eaton 93PM-L UPS Installation and Operation manual, listed in paragraph [1.8 For More Information](#), for the UPS terminal locations and termination recommendations.
3. Route the Output Ground cable from the UPS cabinet through the wiring access pass-through to the ground terminals in the lower cabinet area. See [Figure 21](#).
4. Connect the Output Ground cable to the IAC-B ground terminals.
5. Connect the MIS input cables (phase A, B and C) to the MIS breaker terminals, See [Figure 24](#).
6. Connect the IAC-B neutral disconnect wiring to the UPS neutral disconnect terminals.



7. **BIB Breaker (if Installed):** Route the UPS Bypass cables to the IAC-B Bypass Input Breaker (BIB) (phase A, B, and C) through the bottom UPS and IAC-B inter-cabinet wiring access pass-through to the BIB breaker input terminals.
8. Route the Bypass Ground cable from the UPS cabinet through the wiring access pass-through to the ground terminals in the lower cabinet area.
9. Connect the Bypass Ground cable to the IAC-B ground terminals.
10. Connect the BIB input cables (phase A, B and C) to the BIB breaker terminals.
11. **RIB Breaker (if Installed):** Route the UPS Rectifier Input cables to the IAC-B Rectifier Input Breaker (RIB) (phase A, B, and C) through the bottom UPS and IAC-B inter-cabinet wiring access pass-through to the RIB input terminals.
12. Route the Rectifier Ground cable from the UPS cabinet through the wiring access pass-through to the ground terminals in the lower cabinet area.
13. Connect the Rectifier Ground cable to the IAC-B ground terminals.
14. Connect the RIB input cables (phase A, B and C) to the RIB breaker terminals.
15. Reinstall all safety shield panels previously removed and secure with the retained hardware.
16. Close the outside door and secure the latch.
17. After the IAC-B is installed and wired, return to the applicable Eaton 93PM-L UPS Installation and Operation manual, listed in paragraph [1.8 For More Information](#), to complete the UPS wiring.

Figure 24. IAC-B breaker Input Terminal Detail



## 4.6 Initial Startup

Startup and operational checks must be performed by an authorized Eaton Customer Service Engineer, or the warranty terms specified in [9.1 Warranty](#) become void. This service is offered as part of the sales contract for the UPS. Contact an Eaton service representative in advance (usually a two-week notice is required) to reserve a preferred startup date.

## 4.7 Completing the Installation Checklist

The final step in installing the IAC-B is completing the following Installation Checklist. This checklist ensures that you have completely installed all hardware, cables, and other equipment. Complete all items listed on the checklist to ensure a smooth installation. Make a copy of the Installation Checklist before filling it out, and retain the original.

After the installation is complete, an Eaton Customer Service Engineer must verify the operation of the UPS system and commission it to support the critical load. The service representative cannot perform any installation tasks other than verifying software and operating setup parameters. Service personnel may request a copy of the completed Installation Checklist to verify all applicable equipment installations have been completed.



### NOTE

The Installation Checklist **MUST** be completed prior to starting the UPS system for the first time.

---

### 4.7.1 Installation Checklist

- All packing materials and restraints have been removed from each cabinet.
- The IAC-B is installed on a level floor suitable for computer or electronic equipment.
- The IAC-B is placed in its installed location.
- The IAC-B is secured to the building floor, if required.
- All conduits and cables are properly routed between the IAC-B and the UPS.
- Interface wiring between the IAC-B and UPS cabinets is properly installed.
- A ground conductor is properly installed.
- All power cables are properly sized and terminated.
- Output is wired to the critical load.
- All terminal cover plates are installed.
- Air conditioning equipment is installed and operating correctly.
- The area around the UPS system is clean and dust-free.
- Adequate workspace exists around the IAC-B and other cabinets.
- Adequate lighting is provided around all IAC-B and UPS equipment.
- A 120 Vac service outlet is located within 7.5m (25 ft) of the IAC-B and UPS equipment.
- Startup and operational checks are performed by an authorized Eaton Customer Service Engineer.
- Visit [www.eaton.com/pq/register](http://www.eaton.com/pq/register) to register the new Eaton UPS/Eaton UPS Accessory.



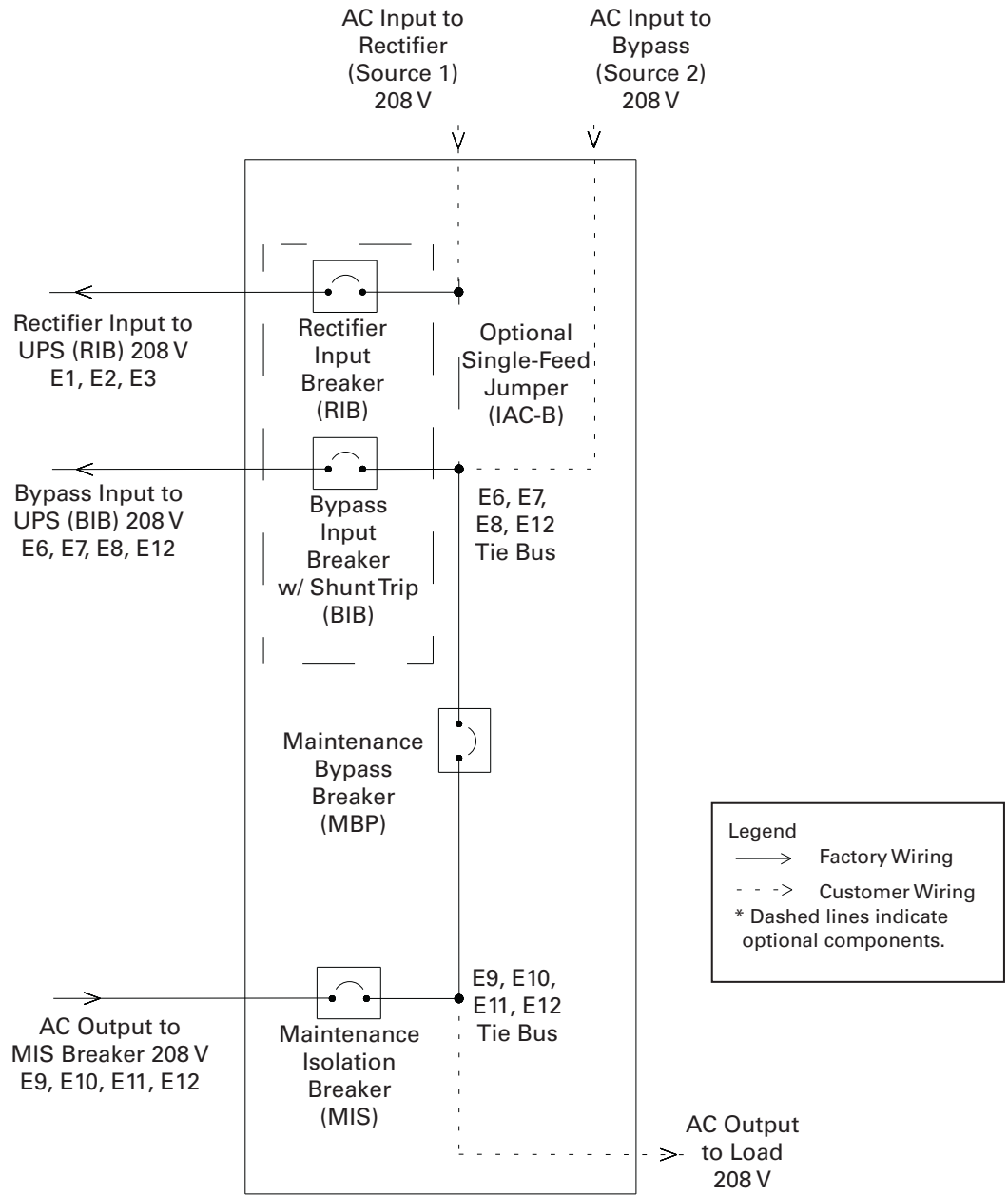
# Chapter 5 Onelines, Schematics, and Wiring Diagrams

## 5.1 Onelines, Schematics, and Wiring Diagrams

### 5.1.1 Onelines

Figure 25 shows the simplified internal structure of the Integrated Accessory Cabinet–Bypass (IAC-B):

Figure 25. 93PM-L 160/200kW IAC-B Oneline



## 5.1.2 Schematics

Figure 26 through Figure 28 show the schematics for the various IAC-B model configurations.

**Figure 26. 93PM-L 160/200kW IAC-B – 2 Breaker Maintenance Bypass**

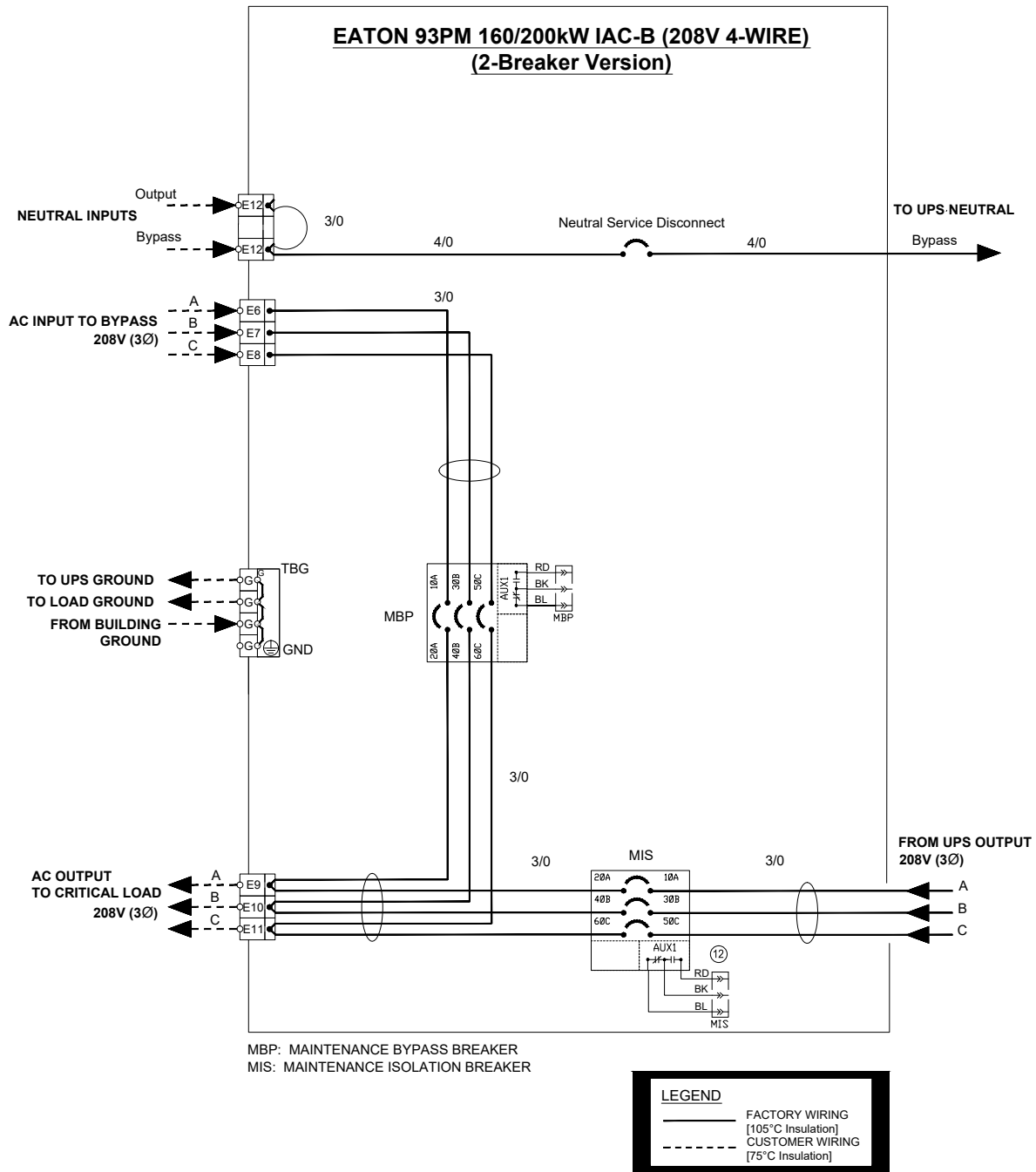


Figure 27. 93PM-L 160/200kW IAC-B – 3 Breaker Maintenance Bypass

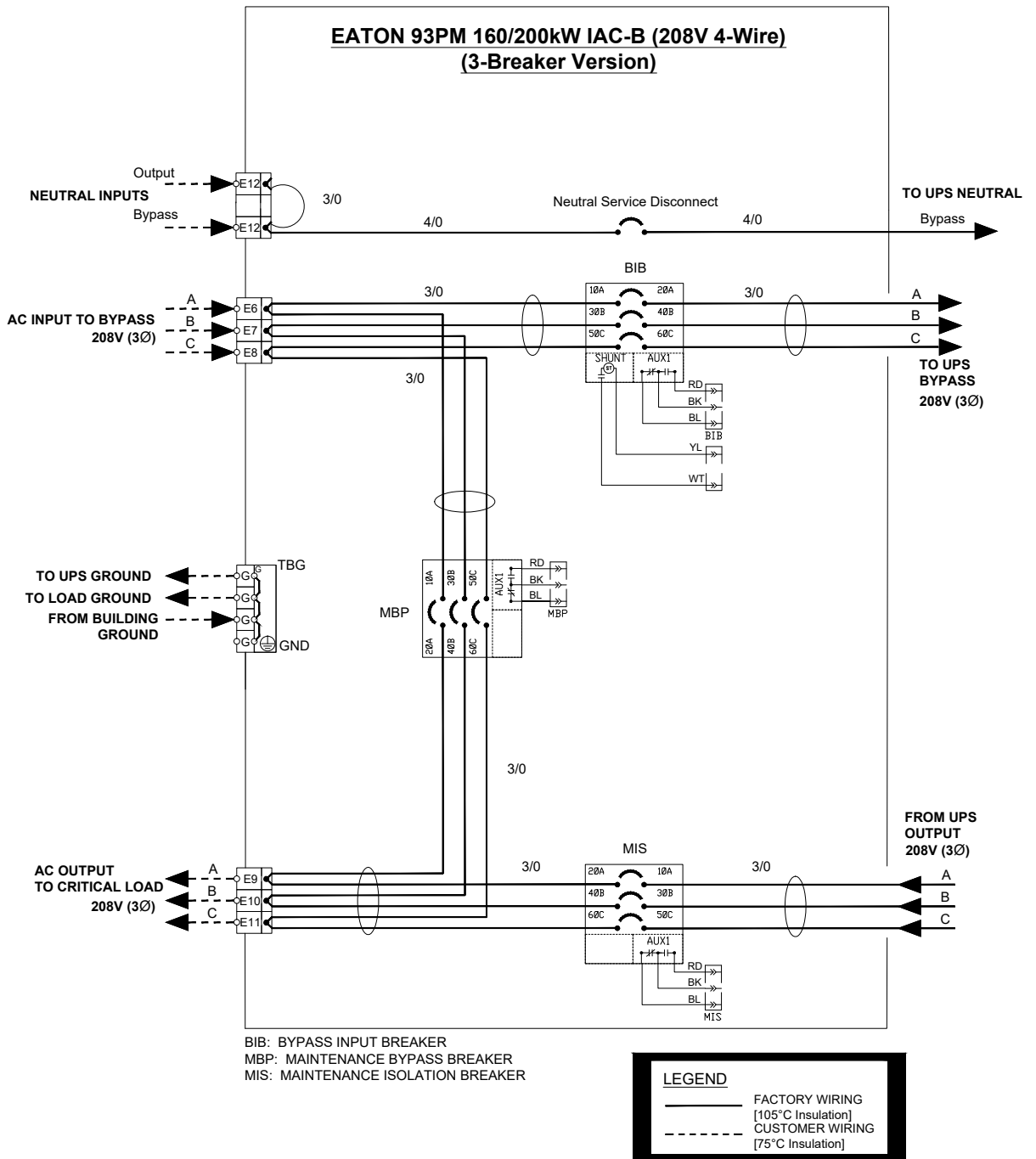
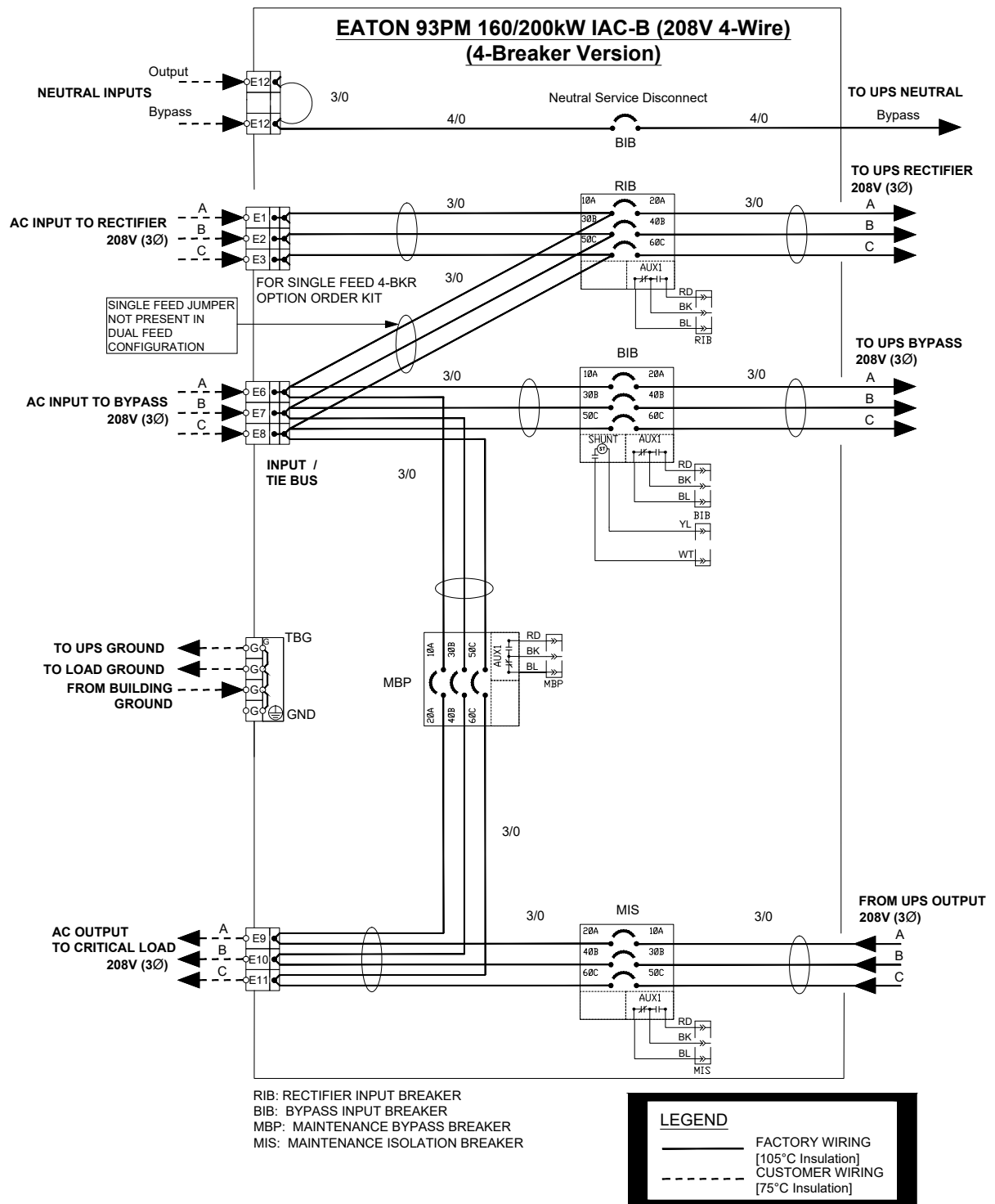


Figure 28. 93PM-L 160/200kW IAC-B – 4 Breaker Maintenance Bypass

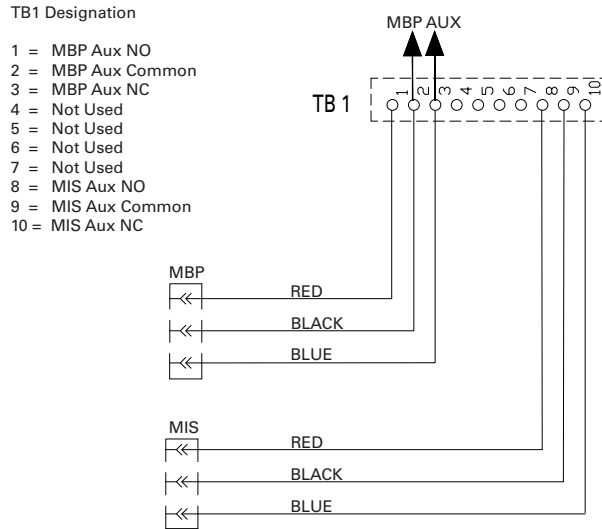




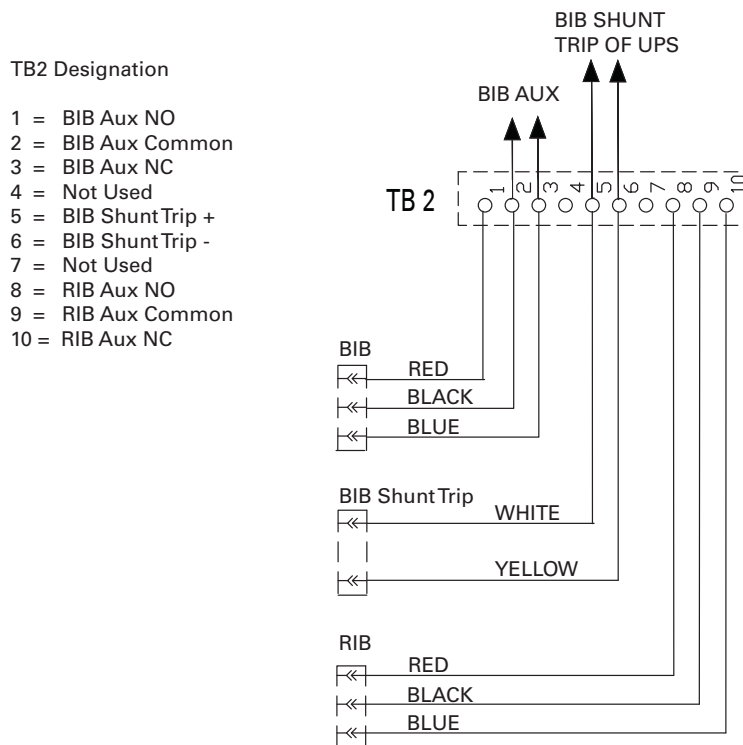
### 5.1.3 Terminal Block Wiring Diagrams

Figure 29 through Figure 31 show the terminal block wiring diagrams for the various IAC-B model configurations.

**Figure 29. IAC-B Terminal Block 1 – Wiring Diagram**



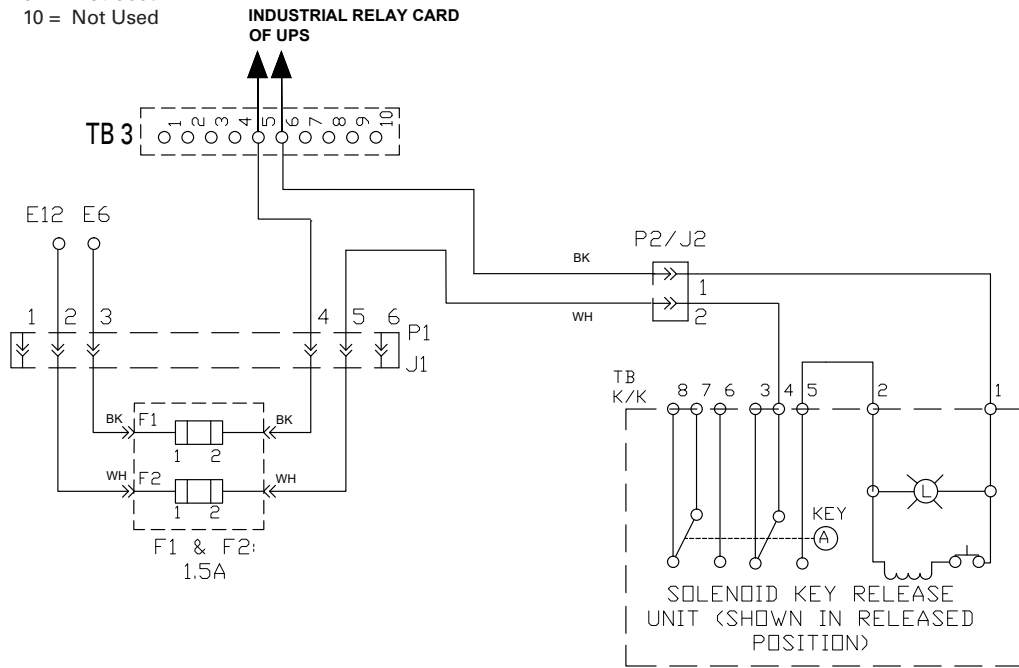
**Figure 30. IAC-B Terminal Block 2 – Wiring Diagram**



**Figure 31. IAC-B Terminal Block 3 – Wiring Diagram**

TB3 Designation

- 1 = Not Used
- 2 = Not Used
- 3 = Not Used
- 4 = Not Used
- 5 = Ind Relay Aux NC
- 6 = Ind Relay Aux Common
- 7 = Not Used
- 8 = Not Used
- 9 = Not Used
- 10 = Not Used



## Chapter 6 Operation

### 6.1 IAC-B Operating Instructions

This section describes how to operate the Integrated Accessory Cabinet-Bypass (IAC-B).

- 
- NOTE 1** Before using the IAC-B, ensure all installation tasks are complete and a preliminary startup has been performed by authorized service personnel. The preliminary startup verifies all electrical interconnections to ensure the installation was successful and the system operates properly.
- NOTE 2** Read this section of the manual and have thorough knowledge of UPS and IAC-B operation before attempting to operate any of the controls.
- 

#### 6.1.1 IAC-B Breakers

The descriptions provide a brief overview of the IAC-B breaker use. [Figure 32](#) and [Figure 33](#) identify and show the location of the breakers on the IAC-B.

- **Maintenance Bypass Breaker** – The Maintenance Bypass Breaker (MBP) transfers the load from the UPS output to the bypass input feeder.
- **Maintenance Isolation Breaker** – The Maintenance Isolation Breaker (MIS) isolates the UPS from the bypass feed and the load.
- **Bypass Input Breaker** – (Optional – available in the three and four breaker IAC-B configurations) The Bypass Input Breaker (BIB) provides a single point of input power control to the UPS on single-feed systems or bypass input power control to the UPS on dual-feed systems. Using the BIB easily removes power from the UPS for servicing.
- **Rectifier Input Breaker** – (Optional – only available in the four breaker IAC-B configurations) The Rectifier Input Breaker (RIB) provides rectifier input power control to the UPS on dual-feed systems. Using the RIB easily removes power from the UPS for servicing.

### 6.2 Using the UPS when an IAC-B is Installed

To operate the IAC-B:

1. Open the front door by lifting the latch from the bottom and turning to the right (counterclockwise) and swing the door open.
2. Close the IAC-B maintenance bypass input feeder circuit breaker.
3. If an BIB is installed, close the IAC-B bypass input feeder breaker.
4. If an RIB is installed, close the IAC-B rectifier input feeder breaker.
5. Verify that the IAC-B circuit breakers are set as follows (see [Figure 32](#), or [Figure 33](#) for breaker locations):

MBP	<b>OPEN</b>
MIS	<b>CLOSED</b>
BIB (if installed)	<b>CLOSED</b>
RIB (if installed)	<b>CLOSED</b>

6. Start the UPS. Refer to the applicable Eaton 93PM-L UPS Installation and Operation manual, listed in paragraph [1.8 For More Information](#), for UPS operating procedures.
7. Close the door and secure the latch.

## 6.3 IAC-B Operation – Sliding Interlock Plate

### 6.3.1 Transferring the UPS to Maintenance Bypass

---

 **CAUTION**

---

Only trained personnel familiar with the operation of this equipment should transfer loads. Failure to follow this transfer sequence may cause loss of power to loads.

---

 **CAUTION**

---

In Bypass mode, the critical load is not protected from commercial power interruptions and abnormalities.

---

To transfer the load to maintenance bypass:

1. Open the front door by lifting the latch from the bottom and turning to the right (counterclockwise) and swing the door open.
  2. Verify the BIB (if installed) is closed.
  3. Verify the RIB (if installed) is closed.
  4. Transfer the UPS from normal mode to bypass mode. Refer to the applicable Eaton 93PM-L UPS Installation and Operation manual, listed in paragraph [1.8 For More Information](#), for UPS operating procedures.
- 

 **WARNING**

---

Power is present inside the cabinets.

---

 **CAUTION**

---

Failure to close the MBP before opening the MIS will result in the loss of power to the critical load.

---

5. Close the MBP.
  6. Slide the bypass interlock plate upward (see [Figure 32](#)).
  7. Open the MIS.  
The critical load is supplied by the maintenance bypass source.
  8. Shut down the UPS. Refer to the applicable Eaton 93PM-L UPS Installation and Operation manual, listed in paragraph [1.8 For More Information](#), for UPS operating procedures.
- 

 **WARNING**

---

The BIB and RIB (if installed) or the bypass feeder breaker must be opened to electrically isolate the UPS.

---

9. If installed, open the BIB.
10. If installed, open the RIB.
11. Close the door and secure the latch.

### 6.3.2 Transferring the UPS from Maintenance Bypass

---



Only trained personnel familiar with the operation of this equipment should transfer loads. Failure to follow this transfer sequence may cause loss of power to loads.

---

To transfer the load from maintenance:

1. Open the front door by lifting the latch from the bottom and turning to the right (counterclockwise) and swing the door open.
  2. If installed, close the BIB.
  3. If installed, close the RIB.
  4. Start the UPS in bypass mode. Refer to the applicable Eaton 93PM-L UPS Installation and Operation manual, listed in paragraph [1.8 For More Information](#), for UPS operating procedures.
- 

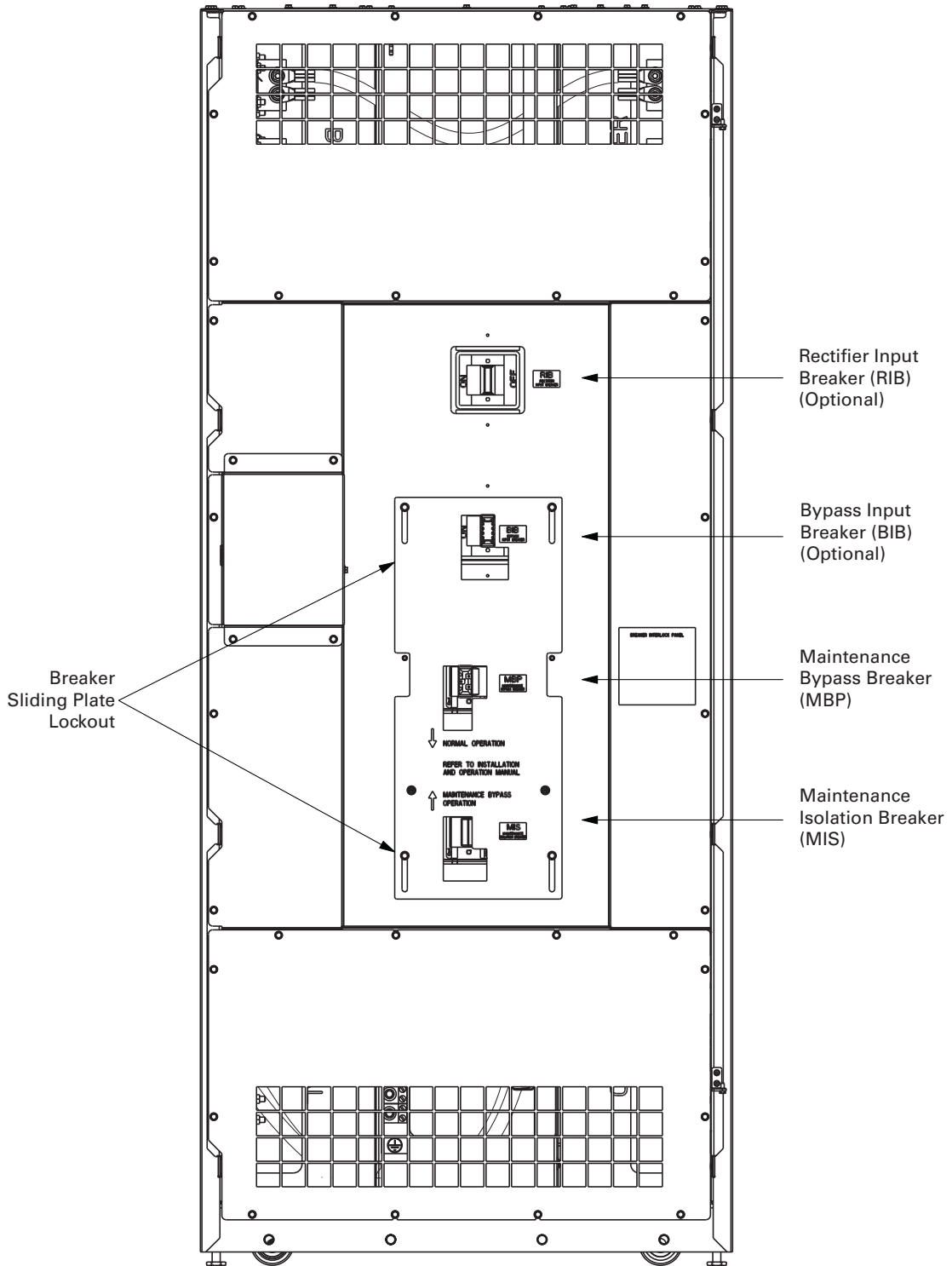


Failure to close the MIS before opening the MBP will result in the loss of power to the critical load.

---

5. Close the MIS.
6. Slide the bypass interlock plate downward (see [Figure 32](#)).
7. Open the MBP.
8. Close the door and secure the latch.
9. Transfer the UPS to Normal mode. Refer to the applicable Eaton 93PM-L UPS Installation and Operation manual, listed in paragraph [1.8 For More Information](#), for UPS operating procedures.

Figure 32. Eaton 93PM-L IAC-B Breakers – Sliding Plate Lockout



160/200 kW 4-Breaker IAC-B  
With Sliding Plate Lockout

## 6.4 IAC-B Operation – Trapped Key Interlock

### 6.4.1 Transferring the UPS to Maintenance Bypass

---

 **CAUTION**

Only trained personnel familiar with the operation of this equipment should transfer loads. Failure to follow this transfer sequence may cause loss of power to loads.

---

 **CAUTION**

In Bypass mode, the critical load is not protected from commercial power interruptions and abnormalities.

1. Open the front door by lifting the latch from the bottom and turning to the right (counterclockwise) and swing the door open.
2. Verify the BIB (if installed) is closed.
3. Verify the RIB (if installed) is closed.
4. Transfer the UPS from normal mode to bypass mode. Refer to the applicable Eaton 93PM-L UPS Installation and Operation manual, listed in paragraph [1.8 For More Information](#), for UPS operating procedures.

---

 **WARNING**

Power is present inside the cabinets. Failure to follow these instructions may result in severe injury or death.

5. Verify the UPS on Bypass indicator on the IAC-B is illuminated (see [Figure 33](#) and [Figure 34](#)).



**NOTE**

Key “A” can be removed from the solenoid lock only when the UPS on Bypass indicator is illuminated indicating the UPS is on bypass.

6. Press and hold the solenoid lock pushbutton. Unlock and remove key “A” from the solenoid lock (see [Figure 34](#)).

---

 **CAUTION**

Failure to close the MBP before opening the MIS will result in the loss of power to the critical load.

7. Insert key “A” into lock “A” on the MBP trapped key lock. Unlock and close the MBP.
8. Remove key “B” from the MBP trapped key lock “B”.
9. Insert key “B” into lock “B” on the MIS trapped key lock. Open the MIS.
10. Lock the MIS and remove key “A” from the MIS trapped key lock “A”.
11. Insert key “A” into the solenoid lock and lock.  
The critical load is supplied by the maintenance bypass source.
12. Shut down the UPS. Refer to the applicable Eaton 93PM-L UPS Installation and Operation manual, listed in paragraph [1.8 For More Information](#), for UPS operating procedures.

---

 **WARNING**

The BIB and RIB (if installed) must be opened to electrically isolate the UPS.

---

13. If installed, open the BIB.
14. If installed, open the RIB.
15. Close the door and secure the latch.

### 6.4.2 Transferring the UPS from Maintenance Bypass



Only trained personnel familiar with the operation of this equipment should transfer loads. Failure to follow this transfer sequence may cause loss of power to loads.

---

To transfer the load from maintenance:

1. Open the front door by lifting the latch from the bottom and turning to the right (counterclockwise) and swing the door open.
  2. If installed, close the BIB.
  3. If installed, close the RIB.
  4. Start the UPS in bypass mode. Refer to the applicable Eaton 93PM-L UPS Installation and Operation manual, listed in paragraph [1.8 For More Information](#), for UPS operating procedures.
  5. Press and hold the solenoid lock pushbutton. Unlock and remove key “A” from the solenoid lock (see [Figure 33](#) and [Figure 34](#)).
- 



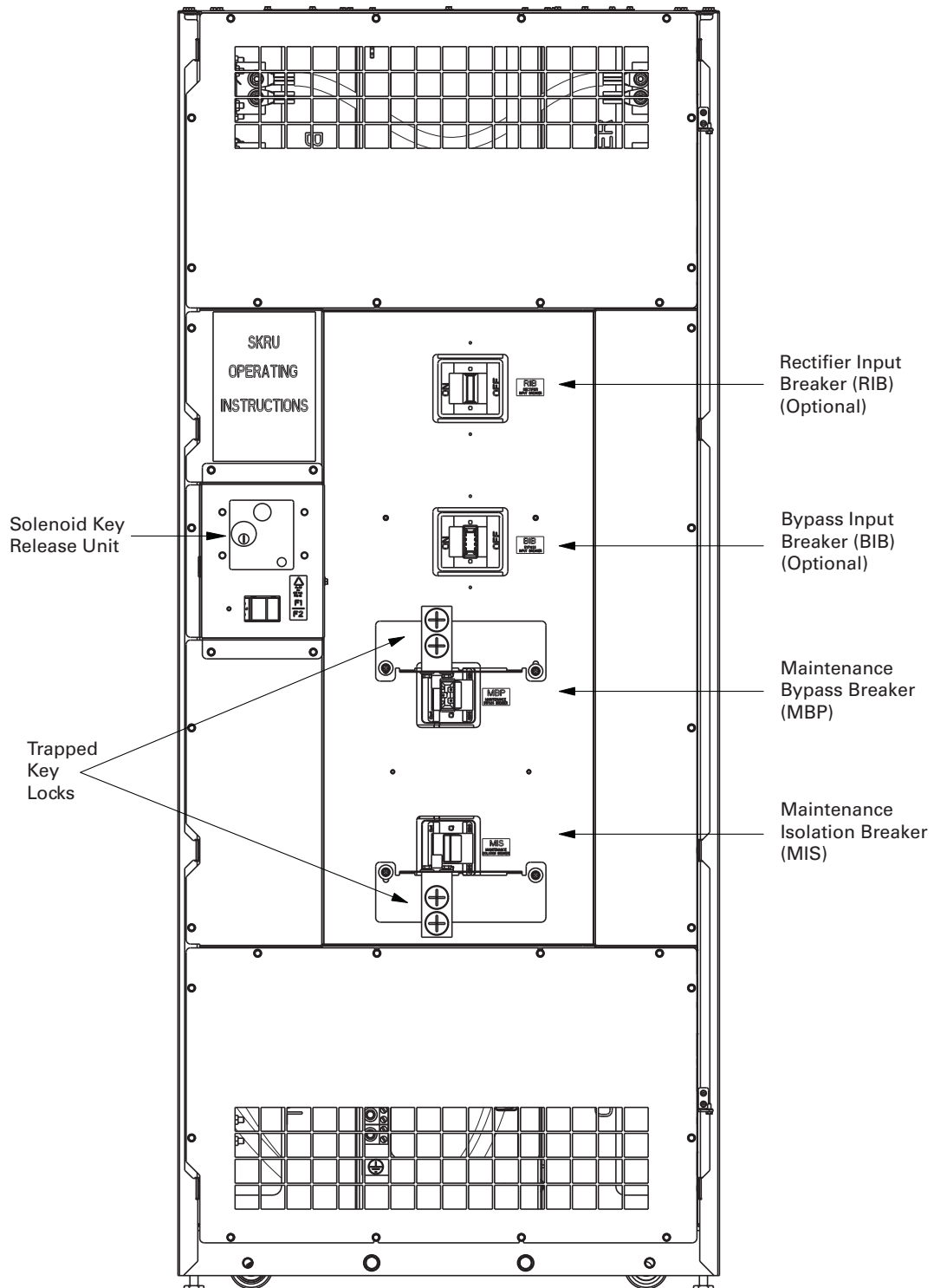
Failure to close the MIS before opening the MBP will result in the loss of power to the critical load.

---

6. Insert key “A” into lock “A” on the MIS trapped key lock. Unlock and close the MIS.
7. Remove key “B” from the MIS trapped key lock “B”.
8. Insert key “B” into lock “B” on the MBP trapped key lock. Open the MBP.
9. Lock the MBP and remove key “A” from the MBP trapped key lock “A”.
10. Insert key “A” into the solenoid lock and lock.
11. Close the front door and secure the latch.
12. Transfer the UPS to Normal mode. Refer to the applicable Eaton 93PM-L UPS Installation and Operation manual, listed in paragraph [1.8 For More Information](#), for UPS operating procedures.

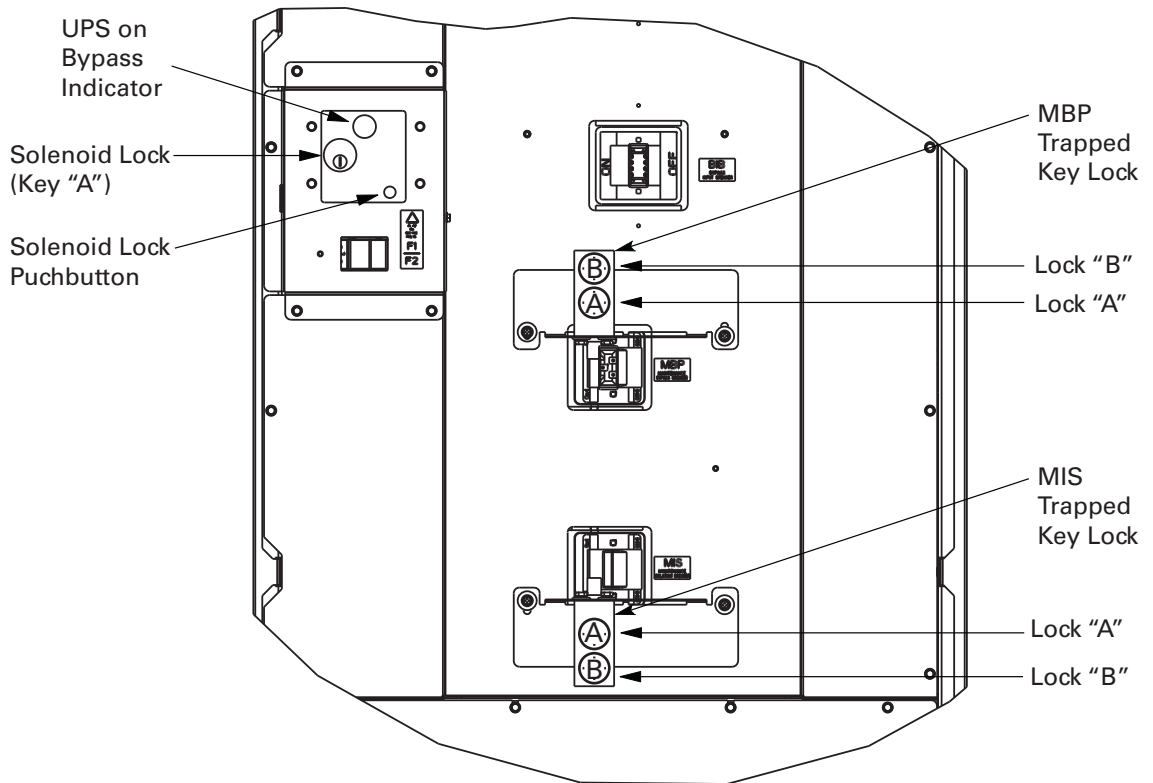


Figure 33. Eaton 93PM-L IAC-B Breakers – Trapped Key Interlock



160/200 kW 4-Breaker IAC-B  
With Trapped Key Interlock

Figure 34. Eaton 93PM-L IAC-B – Trapped Key Interlock Detail



## Chapter 7 Maintenance

### 7.1 Maintenance

The components inside the Integrated Accessory Cabinet-Bypass (IAC-B) are secured to a sturdy metal frame. All repairable parts and assemblies are located for easy removal, with very little disassembly. This design allows authorized service personnel to perform routine maintenance and servicing quickly.

You must schedule periodic performance checks of the UPS system to keep it running properly. Regular routine checks of operation and system parameters enable your system to function efficiently for many trouble-free years.

#### 7.1.1 Important Safety Instructions

Remember that your UPS system is designed to supply power **EVEN WHEN DISCONNECTED FROM THE UTILITY POWER.**



- No user serviceable components.
  - Servicing and maintenance should be performed by qualified service personnel only.
  - LETHAL VOLTAGE PRESENT. This unit should not be operated with the cabinet doors open or protective panels removed. Do not make any assumptions about the electrical state of any cabinet in the UPS system. Failure to follow these instructions may result in serious injury or death.
- 

### 7.2 Performing Preventive Maintenance

The UPS system requires very little preventive maintenance. However, the system should be inspected periodically to verify that the units are operating normally. Record maintenance results and any corrective actions in a suitable log.

#### 7.2.1 DAILY Maintenance

Perform the following steps daily:

1. Check the area surrounding the UPS system. Ensure the area is not cluttered, allowing free access to the unit.
2. Ensure the air intakes on the Accessory cabinets are not blocked.
3. Ensure the operating environment is within the parameters specified in paragraph [3.2.1 Environmental and Installation Considerations](#) and [8.1 Product Specifications](#).

#### 7.2.2 PERIODIC Maintenance

Periodic inspections of the IAC-B should be made to determine if components, wiring, and connections exhibit evidence of overheating. Particular attention should be given to the compression lug connections. Maintenance procedures should specify that the compression lug connections be retorqued to values listed in this manual.

#### 7.2.3 ANNUAL Maintenance

Annual preventive maintenance should be performed only by authorized service personnel familiar with maintenance and servicing of the UPS system. Contact an Eaton service representative for more information about service offerings.

### **7.3 Maintenance Training**

A basic training course, available from Eaton, gives you a competent working knowledge of the UPS system operation and teaches you how to perform first level corrective maintenance. For more information about training and other services, contact the Customer Reliability Center (see paragraph XRef Getting Help).

## Chapter 8 Product Specifications

### 8.1 Product Specifications

This section provides the following specifications:

- Model Number
- Input specifications
- Output specifications
- Environmental and safety specifications

#### 8.1.1 Model Numbers

The Integrated Accessory Cabinet-Bypass (IAC-B) is available in two power rating models to meet the needs of the Eaton 93PM-L (208V) 160/200kW UPS product line.

<b>Integrated Accessory Cabinet-Bypass (IAC-B) Model</b>	<b>Description</b>
Eaton 93PM-L 160kW IAC-B	IAC-B for the 160kW 93PM-L (208V) UPS Frame
Eaton 93PM-L 200kW IAC-B	IAC-B for the 200kW 93PM-L (208V) UPS Frame

#### 8.1.2 Specifications

The following sections detail the input, output, and environmental and safety specifications for the IAC-B.

##### 8.1.2.1 Input

<b>Operating Input Voltage Range</b>	208 Vac, 60 Hz
<b>Input Wiring</b>	3 wire + neutral + ground (PE)
<b>Operating Frequency Range</b>	60 Hz $\pm$ 5 Hz
<b>Operating Input Current</b>	See <a href="#">Table 4</a> for current ratings.

##### 8.1.2.2 Output

<b>Operating Output Voltage</b>	208 Vac, 60 Hz
<b>Output Wiring:</b>	3 wire + neutral + ground (PE)
<b>Operating Output Frequency Range</b>	60 Hz $\pm$ 5 Hz
<b>Output Current</b>	See <a href="#">Table 4</a> for current ratings.

##### 8.1.2.3 Environmental and Safety Specifications

<b>Operating Temperature</b>	5 to 40°C (41 to 104°F). The recommended operating temperature is 25°C (77°F)
<b>Storage Temperature</b>	-25 to +55°C (-13 to +131°F)
<b>Operating Altitude</b>	Maximum 1500m (5000 ft) at 40°C without derating

## Product Specifications

<b>Ventilation</b>	Natural convection air cooling for top or rear exhaust
<b>Relative Humidity (operating and storage)</b>	5–95%, noncondensing
<b>Acoustical Noise</b>	Not applicable
<b>Safety Conformance</b>	UL1778 5 <sup>th</sup> edition
<b>Agency Markings</b>	cULus

## Chapter 9 Warranty

### 9.1 Warranty

#### Limited FACTORY WARRANTY for Three-Phase Eaton 93PM UPS and 93PM UPS Accessory Products

**WARRANTOR:** The warrantor for the limited warranties set forth herein is Eaton ("Eaton").

**LIMITED WARRANTY:** This limited warranty (this "Warranty") applies only to the original end-user (the "End-User") of the Eaton Three-Phase 93PM UPS and 93PM UPS Accessory Products (the "Product") and cannot be transferred. This restriction applies even in the event that the Product is initially sold by Eaton for resale to an End-User. This Warranty gives you specific legal rights, and you may also have other rights which vary from State to State (or jurisdiction to jurisdiction).

**WHAT THIS LIMITED WARRANTY COVERS:** The warrantor warrants, with the terms of this Warranty, that the Eaton three-phase UPS electronics, Eaton-built accessories, and Eaton-built battery cabinets (individually and collectively, the "Warranted Items") are free from defects in material and workmanship.

For Product installed (and currently located) in the fifty (50) United States and the District of Columbia, if, in the opinion of Eaton, a Warranted Item is defective, Eaton's sole obligation, at the option of Eaton, will be to refurbish or replace such defective Warranted Item (including the costs of providing diagnosis, service, and labor ["labor coverage"]). The defective Warranted Item will be refurbished or replaced onsite at the End-User's location or such other location as determined by Eaton. Any parts that are replaced may be new or reconditioned. All parts replaced by Eaton shall become the property of Eaton.

For Product installed (and currently located) outside the fifty (50) United States and the District of Columbia, if, in the opinion of Eaton, a Warranted Item is defective, Eaton's sole obligation, at the option of Eaton, will be to refurbish or replace such defective Warranted Item (not including the costs of labor coverage). The defective Warranted Item will be refurbished or replaced onsite at the End-User's location or such other location as determined by Eaton. Any parts that are replaced may be new or reconditioned. All parts replaced by Eaton shall become the property of Eaton.

**LIMITED WARRANTY PERIOD:** The period covered by this Warranty for Product installed (and currently located) in the fifty (50) United States and the District of Columbia is six (6) months from the date of Product purchase for labor coverage when no startup is performed by an authorized Eaton Customer Service Engineer or Agent or twelve (12) months from the date of Product purchase with startup performed by an authorized Eaton Customer Service Engineer or Agent and twelve (12) months from the date of Product purchase or eighteen (18) months from date of Product shipment, whichever occurs first, for the refurbishment/replacement of parts.

The period covered by this Warranty for Product installed (and currently located) outside the fifty (50) United States and the District of Columbia is twelve (12) months from the date of Product purchase or eighteen (18) months from the date of Product shipment, whichever occurs first, for the refurbishment/replacement of parts.

**WHAT THIS LIMITED WARRANTY DOES NOT COVER:** This Warranty does not cover any defects or damages caused by: (a) failure to properly store the Product before installation, including the "trickle charge" of batteries no later than the date indicated on the packaging; (b) shipping and delivery of the Product if shipping is FOB Factory; (c) neglect, accident, fire, flood, lightning, vandalism, acts of God, Customer's neglect, abuse, misuse, misapplication, incorrect installation; (d) repair or alteration not authorized in writing by Eaton personnel or performed by an authorized Eaton Customer Service Engineer or Agent; or (e) improper testing, operation, maintenance, adjustment, or any modification of any kind not authorized in writing by Eaton personnel or performed by an authorized Eaton Customer Service Engineer or Agent.

This Warranty is not valid: if the Product's serial numbers have been removed or are illegible. Any Warranted Items repaired or replaced pursuant to this Warranty will be warranted for the remaining portion of the original Warranty subject to all the terms thereof. Eaton does not provide a labor warranty for Product located outside of the fifty (50) United States or the District of Columbia. **Any equipment, parts, or materials included in the**

**Product and not manufactured by Eaton are warranted solely by the manufacturer of such equipment, parts, or materials and are not included as part of this Warranty. Batteries are not warranted by Eaton.**

**THIS WARRANTY IS THE END-USER'S SOLE REMEDY AND IS EXPRESSLY IN LIEU OF, AND THERE ARE NO OTHER, EXPRESSED OR IMPLIED GUARANTEES OR WARRANTIES (INCLUDING ANY IMPLIED WARRANTY OF MERCHANTABILITY OR FITNESS FOR ANY PURPOSE, WHICH ARE EXPRESSLY DISCLAIMED). SOME STATES OR JURISDICTIONS DO NOT ALLOW THE EXCLUSION OF EXPRESS OR IMPLIED WARRANTIES, SO THE ABOVE EXCLUSION MAY NOT APPLY TO YOU. IN THAT EVENT, SUCH WARRANTIES ARE LIMITED IN DURATION TO THE LIMITED WARRANTY PERIOD. SOME STATES OR JURISDICTIONS DO NOT ALLOW LIMITATIONS ON HOW LONG AN IMPLIED WARRANTY LASTS OR THE EXCLUSION OR LIMITATION OF INCIDENTAL OR CONSEQUENTIAL DAMAGES, SO THE ABOVE LIMITATIONS AND/OR EXCLUSIONS MAY NOT APPLY TO YOU.**

**LIMITATION OF LIABILITY:** In no event shall Eaton be liable for any indirect, incidental, special or consequential damages of any kind or type whatsoever, resulting from or in connection with any claim or cause of action, whether brought in contract or in tort (including negligence and strict liability). Some States or jurisdictions do not allow the exclusion of limitation of incidental or consequential damages, so the above limitation or exclusion may not apply to you. Eaton shall not be responsible for failure to provide service or parts due to causes beyond Eaton's reasonable control. In no case will Eaton's liability under this Warranty exceed the replacement value of the Warranted Items.

**END-USER'S OBLIGATIONS:** In order to receive the benefits of this Warranty, the End-User must register the product warranty (via mail or online at [www.eaton.com/pg/register](http://www.eaton.com/pg/register) "product registration"); use the Product in a normal way; follow the Product's user's guide; and protect against further damage to the Product if there is a covered defect.

**OTHER LIMITATIONS:** Eaton's obligations under this Warranty are expressly conditioned upon receipt by Eaton of all payments due to it (including interest charges, if any). During such time as Eaton has not received payment of any amount due to it for the Product, in accordance with the contract terms under which the Product is sold, Eaton shall have no obligation under this Warranty. Also during such time, the period of this Warranty shall continue to run and the expiration of this Warranty shall not be extended upon payment of any overdue or unpaid amounts.

**COSTS NOT RELATED TO WARRANTY:** The End-User shall be invoiced for, and shall pay for, all services not expressly provided for by the terms of this Warranty, including without limitation site calls involving an inspection that determines no corrective maintenance is required. Any costs for replacement equipment, installation, materials, freight charges, travel expenses, or labor of Eaton representatives outside the terms of this Warranty will be borne by the End-User.

**OBTAINING WARRANTY SERVICE:** In the USA, call the Eaton Customer Reliability Center 7x24 at 800-843-9433. Outside of the USA, call your local Eaton sales or service representative, or call the Eaton Customer Reliability Center in the United States at 919845-3633. For comments or questions about this Limited Factory Warranty, write to the Customer Quality Representative, 8609 Six Forks Road, Raleigh, North Carolina 27615 USA.







P-164000764 01