

Eaton® 93PM Integrated Battery Cabinet-Small Welded

IBC-SW
Installation Manual



p/n: 164000639
Revision 03

IMPORTANT SAFETY INSTRUCTIONS SAVE THESE INSTRUCTIONS

This manual contains important instructions that should be followed during installation and maintenance of the UPS and batteries. Read all instructions before operating the equipment and save this manual for future reference.

CONSIGNES DE SÉCURITÉ IMPORTANTES – CONSERVER CES INSTRUCTIONS

Ce manuel comporte des instructions importantes que vous êtes invité à suivre lors de toute procédure d'installation et de maintenance des batteries et de l'onduleur. Veuillez consulter entièrement ces instructions avant de faire fonctionner l'équipement et conserver ce manuel afin de pouvoir vous y reporter ultérieurement.



IMPORTANT

To ensure you have the most up-to-date content and information for this product, please review the latest manual revision on our website, www.eaton.com/93PM.

Eaton reserves the right to change specifications without prior notice. Modbus is a registered trademark of Schneider Automation, Inc. MOXA is a registered trademark and MGate is a trademark of MOXA, Inc. Spiralock is a registered trademark of Spiralock Corporation. KIRK is a registered trademark of Kirk Key Interlock company, LLC, a subsidiary of Halma plc. National Electrical Code and NEC are registered trademarks of National Fire Protection Association, Inc. ERIFLEX and FLEXIBAR are registered trademark of Erico International Corporation. All other trademarks are property of their respective companies.

©Copyright 2017-2019 Eaton, Raleigh, NC, USA. All rights reserved. No part of this document may be reproduced in any way without the express written approval of Eaton.

Table of Contents

1 Introduction	1
1.1 Installation Features	2
1.2 Optional Thermal Sensor	2
1.3 Model Configurations	3
1.4 Using This Manual	3
1.5 Conventions Used in This Manual	3
1.6 Symbols, Controls, and Indicators	4
1.7 For More Information	4
1.8 Getting Help	5
1.9 Equipment Registration	5
2 Safety Warnings	7
3 Installation Plan and Unpacking	11
3.1 Creating an Installation Plan	11
3.2 Preparing the Site	11
3.2.1 Environmental and Installation Considerations	11
3.2.2 IBC–SW Power Wiring Preparation	16
3.2.3 IBC–SW Interface Wiring Preparation	18
3.3 Inspecting and Unpacking the Eaton 93PM IBC–SW	19
3.4 Battery Breaker Location	21
4 Installation	23
4.1 Preliminary Installation Information	23
4.2 Unloading the IBC Cabinet from the Pallet	23
4.3 Installing Power Wiring	29
4.3.1 Line-Up-and-Match Power Wiring	29
4.3.2 Standalone Power Wiring	34
4.4 Installing IBC–SW Interface Wiring	36
4.4.1 Installing Battery Detect Interface Connections	36
4.4.2 Installing Battery Shunt Trip Interface Connections	41
4.4.3 Installing Thermal Sensor Interface Connections	43
4.5 Initial Startup	44
4.6 Completing the Installation Checklist	44
5 Onelines and Schematics	47
5.1 Power Onelines	47
5.2 Interface Onelines	49
5.3 Schematics	49
6 Maintenance	53
6.1 Important Safety Instructions	53

Table of Contents

- 6.2 Performing Preventive Maintenance 53
 - 6.2.1 DAILY Maintenance 53
 - 6.2.2 PERIODIC Maintenance 53
 - 6.2.3 ANNUAL Maintenance 53
 - 6.2.4 BATTERY Maintenance 53
 - 6.2.5 BATTERY Shelf Life 54
- 6.3 Recycling the Used Batteries 54
- 6.4 Maintenance Training 54
- 7 Product Specifications 55**
 - 7.1 Models 55
 - 7.2 Specifications 55
 - 7.2.1 Battery Specifications 55
 - 7.2.2 Environmental and Safety Specifications 56
- 8 Warranty 57**
 - 8.1 Limited Factory Warranty for Three-Phase Eaton 93PM UPS and 93PM UPS Accessory Products 57

List of Figures

Figure 1.	Eaton 93PM Integrated Battery Cabinet–Small Welded	1
Figure 2.	Eaton 93PM UPS and Two 93PM IBC–SWs — Various Configurations.....	2
Figure 3.	Eaton 93PM Integrated Battery Cabinet–Small Welded Dimensions (Front, Right Side, and Rear Views)	13
Figure 4.	Eaton 93PM IBC–SW Dimensions (Top and Bottom Views).....	14
Figure 5.	Eaton 93PM IBC–SW Center of Gravity.....	15
Figure 6.	Eaton 93PM IBC–SW as Shipped on Pallet	20
Figure 7.	Eaton 93PM IBC–SW Battery Breaker Locations – Front View with Cover Removed.....	21
Figure 8.	Removing the Pallet Skids and Supports – Eaton 93PM Integrated Battery Cabinet	25
Figure 9.	Line-Up-and-Match Wiring Access Locations.....	27
Figure 10.	Rear Ventilation	28
Figure 11.	Top Ventilation.....	29
Figure 12.	Wiring Channel Location	31
Figure 13.	DC Power Terminal Locations – Eaton 93PM IBC–SW.....	32
Figure 14.	Wire Tie Anchors	33
Figure 15.	DC Power Terminal Detail – Eaton 93PM IBC–SW.....	33
Figure 16.	Top and Bottom Entry Conduit and Wire Entry Locations	36
Figure 17.	Interface Terminal Locations – Eaton 93PM IBC–SW	38
Figure 18.	Shunt Trip, Battery Detect, and Thermal Sensor Wiring	40
Figure 19.	Interface Terminal Detail – Eaton 93PM IBC–SW	41
Figure 20.	93PM Integrated Battery Cabinet Line-Up-and-Match Power Oneline	47
Figure 21.	93PM Integrated Battery Cabinet Standalone Power Online – One or Two Cabinets	48
Figure 22.	93PM Integrated Battery Cabinet Standalone Power Online – Three or Four Cabinets	48
Figure 23.	93PM Integrated Battery Cabinet Interface Oneline	49
Figure 24.	93PM Integrated Battery Cabinet Schematic.....	50
Figure 25.	93PM Integrated Battery Cabinet — Battery String Detail Schematic.....	51

List of Figures

List of Tables

Table 1.	IBC-SW Cabinet Weights	12
Table 2.	IBC-SW Cabinet Clearances	13
Table 3.	Line-Up-and-Match External Power Wiring Recommendations: Eaton 93PM IBC-SW (432V or 480V)	17
Table 4.	Standalone External Power Wiring Recommendations: Eaton 93PM IBC-SW (432V or 480V)	17
Table 5.	External Power Cable Terminations for the Eaton 93PM IBC-SW	18
Table 6.	Recommended DC Circuit Breaker or Disconnect Ratings (Three or Four IBCs).....	18
Table 7.	IBC TB2 Interface Connections.....	38
Table 8.	IBC TB2 Interface Wiring Terminal Block Terminations	39

List of Tables

Chapter 1 Introduction

The Eaton® Integrated Battery Cabinet-Small Welded (IBC-SW) provides extended emergency short-time backup power for 93PM UPS systems to enhance the usability and reliability of the systems. The IBC-SW safeguards operation during brownouts, blackouts, and other power interruptions providing cost-effective extended battery run time.

The IBC-SW is housed in a single free-standing cabinet and is available in two voltage output options 432 Vdc and 480 Vdc. Up to four IBC-SWs per UPS may be used to meet application runtime needs. The cabinets match the UPS cabinet in style and color. [Figure 1](#) shows the Eaton 93PM IBC-SW.

The IBC-SW is equipped with valve-regulated lead-acid (VRLA) batteries. The 432Vdc version contains a single string of 36 batteries and the 480Vdc version contains a single string of 40 batteries. Removable battery trays with quick disconnects between trays reduce battery maintenance time. A DC-rated circuit breaker within each cabinet provides protection and servicing isolation.

NOTE  Startup and operational checks must be performed by an authorized Eaton Customer Service Engineer, or the warranty terms specified in [Chapter 8 Warranty](#) become void. This service is offered as part of the sales contract for the UPS. Contact an Eaton service representative in advance (a minimum two-week notice is required) to reserve a preferred startup date.

Figure 1. Eaton 93PM Integrated Battery Cabinet-Small Welded



1.1 Installation Features

- Line-up-and-match configurations using factory supplied power wiring or standalone configurations using customer supplied power wiring
- Battery wiring can be run internally through the left or right sides of the IBC-SWs in line-up-and-match configurations, or routed through the top or bottom of the IBC-SWs using conduit in standalone configurations
- Front access panel for access to the battery breaker
- Interface wiring can be routed through the top left or right sides of the IBC-SWs in line-up-and-match configurations or through the top or bottom of the IBC-SWs using conduit in standalone configurations
- Built-in casters for easy cabinet placement
- Cabinet bolt holes are provided for permanently mounting the IBC-SW using the optional Floor Mount Bracket Kit

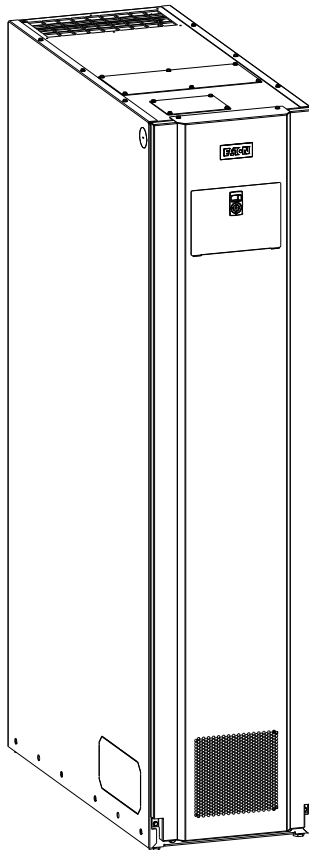
Line-up-and-match battery cabinets are installed adjacent to the UPS. The IBC-SW can be installed on either the left or right side or on both sides of the UPS cabinet (see [Figure 2](#)).

Figure 2. Eaton 93PM UPS and Two 93PM IBC-SWs – Various Configurations

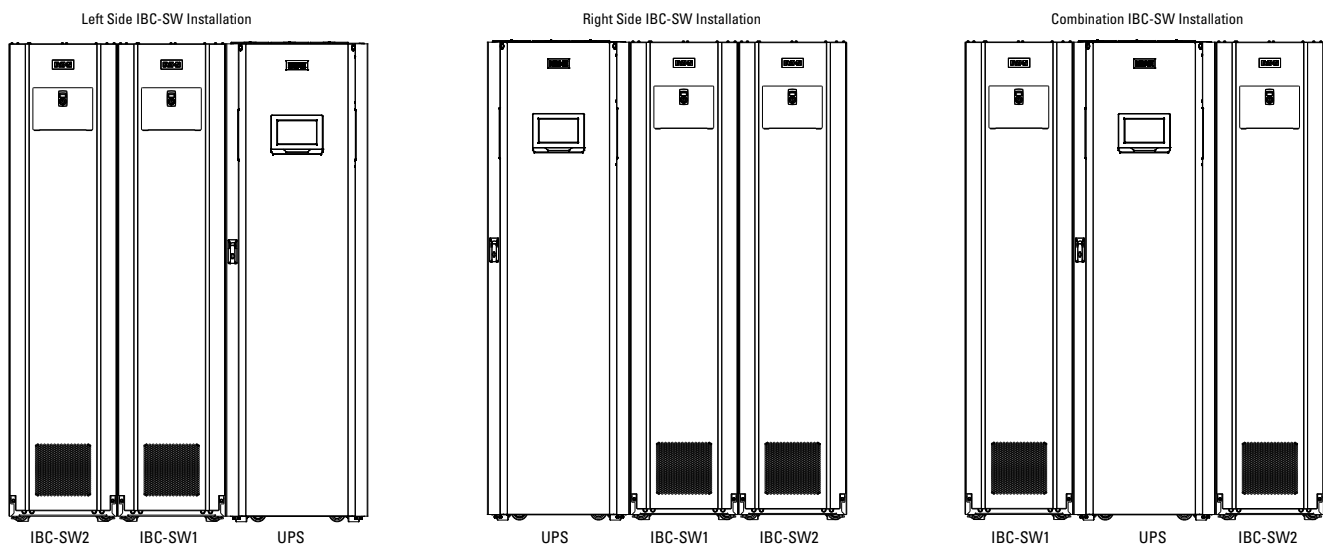

1.2 Optional Thermal Sensor

Thermal runaway protection for VRLA batteries can be provided by installing an optional thermal sensor inside the battery cabinet.

The sensor is wired to an UPS building alarm programmed to turn the charger off when a trip signal is received.

The thermal sensor will maintain the trip state until the temperature it is reset by service. Service should be called to inspect the batteries and reset the sensor in case of such an event.

1.3 Model Configurations

The following model configurations are available:

- 93PM Integrated Battery Cabinet-Small Welded
 - Line-up-and-match, top entry, or bottom entry standalone
 - Top or rear ventilation
 - Contains one battery string with either 36 batteries (432 Vdc version) or 40 batteries (480 Vdc version)
 - Available Eaton PWHR12200W4FR or CSB HRL12200WFR batteries
 - Up to four IBC–SWs can be paralleled with a 93PM or 93PM-L UPS system to extend the runtime

1.4 Using This Manual

This manual describes how to install the IBC–SW and is divided into chapters. Read and understand the procedures described to ensure trouble-free installation and operation.

Read through each procedure before beginning the procedure. Perform only those procedures that apply to the UPS system being installed or operated.

Specifications listed in this manual are subject to change.

1.5 Conventions Used in This Manual

This manual uses these type conventions:

- **Bold type** highlights important concepts in discussions, key terms in procedures, and menu options, or represents a command or option that you type or enter at a prompt.
- *Italic type* highlights notes and new terms where they are defined.
- `Screen type` represents information that appears on the screen or LCD.

Icon	Description
Note	Information notes call attention to important features or instructions.
[Keys]	Brackets are used when referring to a specific key, such as [Enter] or [Ctrl].

In this manual, the term UPS refers only to the UPS cabinet and its internal elements. The term UPS system refers to the entire power protection system – the UPS cabinet, an external battery system, and options or accessories installed.

The term line-up-and-match refers to accessory cabinets that are physically located adjacent to the UPS. The term standalone refers to accessory cabinets that are located separate from the UPS.

Left and right side notations are referenced standing in front of the cabinet.

1.6 Symbols, Controls, and Indicators

The following are examples of symbols used on the UPS or accessories to alert you to important information:



RISK OF ELECTRIC SHOCK - Observe the warning associated with the risk of electric shock symbol.



CAUTION: REFER TO OPERATOR'S MANUAL - Refer to your operator's manual for additional information, such as important operating and maintenance instructions.



This symbol indicates that you should not discard the UPS or the UPS batteries in the trash. This product contains sealed, lead-acid batteries and must be disposed of properly. For more information, contact your local recycling/reuse or hazardous waste center.



This symbol indicates that you should not discard waste electrical or electronic equipment (WEEE) in the trash. For proper disposal, contact your local recycling/reuse or hazardous waste center.

1.7 For More Information

Refer to the following manuals for the listed additional information:

- *Eaton 93PM-L UPS (20–60 kW, 208V) Installation and Operation Manual*
- *Eaton 93PM-L UPS (20–120 kW, 208V) Installation and Operation Manual*
- *Eaton 93PM-L UPS (20–160 kW, 208V) Installation and Operation Manual*
- *Eaton 93PM-L UPS (20–200 kW, 208V) Installation and Operation Manual*
- *Eaton 93PM UPS 480V Three-Wire – 50 kW Frame Installation and Operation Manual*
- *Eaton 93PM UPS 400V/480V Four-Wire – 50 kW Frame Installation and Operation Manual*
- *Eaton 93PM UPS 480V Three-Wire – 100 kW Frame Installation and Operation Manual*
- *Eaton 93PM UPS 400V/480V Four-Wire – 100 kW Frame Installation and Operation Manual*
- *Eaton 93PM UPS 480V Three-Wire 150 kW Frame Installation and Operation Manual*
- *Eaton 93PM UPS 400V/480V Four-Wire – 150 kW Frame Installation and Operation Manual*
- *Eaton 93PM UPS 480V Three-Wire – 200 kW Frame Installation and Operation Manual*
- *Eaton 93PM UPS 400V/480V Four-Wire – 200 kW Frame Installation and Operation Manual*
 - UPS, optional components, and accessory installation instructions, including site preparation, planning for installation, and wiring and safety information. Detailed illustrations of cabinets and optional accessories with dimensional and connection point drawings are provided.
 - UPS operation, including UPS controls, functions of the UPS, standard features and optional accessories, procedures for starting and stopping the UPS, and information about maintenance and responding to system events.
 - Communication capabilities of the UPS system.

Visit www.eaton.com/powerquality or contact an Eaton service representative for information on how to obtain copies of these manuals.

1.8 Getting Help

If help is needed with any of the following:

- Scheduling initial startup
- Regional locations and telephone numbers
- A question about any of the information in this manual
- A question this manual does not answer

Please call the Customer Reliability Center at:

United States:

1-800-843-9433

Canada:

1-800-461-9166 ext 260

All other countries:

Call your local service representative

Please use the following e-mail address for manual comments, suggestions, or to report an error in this manual:

E-ESSDocumentation@eaton.com

1.9 Equipment Registration

Please visit www.eaton.com/pg/register to register your new Eaton UPS / Eaton UPS Accessory.

Model Number:

Serial Number:

Chapter 2 Safety Warnings

IMPORTANT SAFETY INSTRUCTIONS SAVE THESE INSTRUCTIONS

This manual contains important instructions that should be followed during installation and maintenance of the UPS system and batteries. Read all instructions before operating the equipment and save this manual for future reference.

The UPS system is designed for industrial or computer room applications, and contains safety shields behind the door and front panels. However, the UPS system is a sophisticated power system and should be handled with appropriate care.



DANGER

This UPS system contains LETHAL VOLTAGES. All repairs and service should be performed by AUTHORIZED SERVICE PERSONNEL ONLY. There are NO USER SERVICEABLE PARTS inside the UPS.



WARNING

- The UPS system is powered by its own energy source (batteries). The output terminals may carry live voltage even when the UPS is disconnected from an AC source.
 - The battery cabinet contains its own energy source. The internal wiring and output terminals may carry live voltage even when the UPS is not connected to an AC source.
 - To reduce the risk of fire or electric shock, install this UPS system in a temperature and humidity controlled, indoor environment, free of conductive contaminants. Ambient temperature must not exceed 40°C (104°F). Do not operate near water or excessive humidity (95% maximum). The system is not intended for outdoor use.
 - As a result of the connected loads high leakage current is possible. Connection to earth ground is required for safety and proper product operation. Do not check UPS system operation by any action that includes removal of the earth (ground) connection with loads attached.
 - Ensure all power is disconnected before performing installation or service.
 - Batteries can present a risk of electrical shock or burn from high short-circuit current. The following precautions should be observed: 1) Remove watches, rings, or other metal objects; 2) Use tools with insulated handles; 3) Do not lay tools or metal parts on top of batteries; 4) Wear voltage rated gloves and electrical hazard footwear.
 - ELECTRIC ENERGY HAZARD. Do not attempt to alter any UPS system or battery wiring or connectors. Attempting to alter wiring can cause injury.
 - Do not open or mutilate batteries. Released electrolyte is harmful to the skin and eyes. It may be toxic.
-

 **CAUTION**

- Installation or servicing should be performed by qualified service personnel knowledgeable of UPS and battery systems, and required precautions. Keep unauthorized personnel away from equipment. Consider all warnings, cautions, and notes before installing or servicing equipment. **DO NOT DISCONNECT** the batteries while the UPS is in Battery mode.
- Batteries may only be replaced with the same number and type by authorized service personnel. No user serviceable parts.
- The UPS system has been evaluated for use with a maximum of four 93PM EBCs. Use of any other configuration may result in fire, death, and voiding of the warranty.
- Disconnect the charging source prior to connecting or disconnecting battery terminals.
- Determine if the battery is inadvertently grounded. If it is, remove the source of the ground. Contacting any part of a grounded battery can cause a risk of electric shock. An electric shock is less likely if you disconnect the grounding connection before you work on the batteries.
- Proper disposal of batteries is required. Refer to local codes for disposal requirements.
- Do not dispose of batteries in a fire. Batteries may explode when exposed to flame.
- Keep the Accessory cabinet doors closed and front panels installed to ensure proper cooling airflow and to protect personnel from dangerous voltages inside the unit.
- Do not install or operate the UPS system close to gas or electric heat sources.
- Lead-acid batteries can present a risk of fire because they generate hydrogen gas. Do not smoke when near batteries. Do not cause flame or spark in battery area. Discharge static electricity from body before touching batteries by first touching a grounded metal surface.
- The operating environment should be maintained within the parameters stated in this manual.
- Operating temperatures above the recommended range will result in decreased battery life and performance, and will reduce or void the battery warranty. Refer to Terms and Conditions of Sale with Battery Replacement Coverage and the Battery Replacement Price Book for more information. These documents can be found at www.eaton.com/powerquality or contact your service representative for information on how to obtain copies.
- The shelf life for the batteries installed in the IBC is 12 months from the date code on the battery. The recharge date is also stated on a label inside the IBC.
Failure to recharge the batteries before the expiration of the shelf life will result in reduced discharge time, shorter float service life, and will void the warranty.
- Keep surroundings uncluttered, clean, and free from excess moisture.
- Observe all DANGER, CAUTION, and WARNING notices affixed to the inside and outside of the equipment.

 **AVERTISSEMENT!**

- Les batteries peuvent présenter un risque de décharge électrique ou de brûlure par des courts-circuits de haute intensité. Prendre les précautions nécessaires.
 - Pour le remplacement, utiliser le même nombre et modèle des batteries.
-

**ATTENTION!**

- Une mise au rebut réglementaire des batteries est obligatoire. Consulter les règlements en vigueur dans votre localité.
 - Ne jamais jeter les batteries au feu. L'exposition aux flammes risque de les faire exploser.
 - Les accumulateurs au plomb-acide peuvent représenter un risque d'incendie, car ils génèrent de l'hydrogène gazeux. Ne pas fumer près des accumulateurs. Ne pas produire de flamme ou d'étincelle dans la zone de l'accumulateur. Dissiper l'électricité statique de votre corps en touchant une surface reliée à la terre avant de toucher les accumulateurs.
-

Safety Warnings

Chapter 3 Installation Plan and Unpacking

Use the following basic sequence of steps to install the Eaton 93PM Integrated Battery Cabinet:

1. Create an installation plan for the IBC.
2. Prepare your site for the IBC.
3. Inspect and unpack the IBC.
4. Unload and install the IBC, and wire the system.
5. Complete the Installation Checklist.
6. Have authorized service personnel perform preliminary operational checks and start up the system.



NOTE

Startup and operational checks must be performed by an authorized Eaton Customer Service Engineer, or the warranty terms specified in [Chapter 8 Warranty](#) become void. This service is offered as part of the sales contract for the UPS. Contact an Eaton service representative in advance (a minimum two-week notice is required) to reserve a preferred startup date.

3.1 Creating an Installation Plan

Before installing the IBC, read and understand how this manual applies to the system being installed. Use the procedures and illustrations in this section and **Chapter 4 Installation** to create a logical plan for installing the IBC. This section contains the following information:

- Physical features and requirements, including dimensions
- Power wiring installation notes
- Location of conduit and wire entry landing plates
- Location of power terminals

3.2 Preparing the Site

For the UPS system to operate at peak efficiency, the installation site should meet the environmental parameters outlined in this manual. The operating environment must meet the weight, clearance, and environmental requirements specified.

3.2.1 Environmental and Installation Considerations

The UPS system installation, including the IBC, must meet the following guidelines:

- The system must be installed on a level floor suitable for computer or electronic equipment.
- The system must be operated at an altitude no higher than 1500m (5000 ft) without derating. For additional information and assistance with high altitude operation, contact an Eaton service representative (see paragraph [1.8 Getting Help](#)).
- The system must be installed in a temperature and humidity controlled indoor area free of conductive contaminants.
- Specifications are subject to change

Failure to follow guidelines may void your warranty.

The basic environmental requirements for operation of the IBC are:

- The battery cabinet is rated for operation in up to a 40°C (104°F) ambient temperature.
- The batteries are rated for a 25°C (77°F) ambient temperature to extend their useful life.

- Maximum Relative Humidity: 5–95%, noncondensing

 **CAUTION**

It is recommended for optimal battery life and discharge performance to keep the ambient air temperature the battery is used in at 25°C (77°F). Operating temperatures above the recommended range will result in decreased battery life and performance, and will reduce or void the battery warranty. Refer to Eaton's Terms and Conditions of Sale with Battery Replacement Coverage and the Battery Replacement Price Book for more information. These documents can be found at www.eaton.com/powerquality or contact your service representative for information on how to obtain copies.

 **CAUTION**

The shelf life for the batteries installed in the IBC is 12 months from the date code on the battery. The recharge date is also stated on a label inside the IBC.

Failure to recharge the batteries before the expiration of the shelf life will result in reduced discharge time, shorter float service life, and will void the warranty.

The IBC–SW operating environment must meet the weight requirements shown in [Table 1](#) and the size requirements shown in [Figure 3](#) through [Figure 5](#). Dimensions are in millimeters (inches). Specifications are subject to change.

Table 1. IBC-SW Cabinet Weights

Model	Voltage	Shipping	Weight kg (lb)	
			Installed	Point Loading
Eaton 93PM IBC–SW with 1 battery string (36 batteries)	432V	935 (2061)	908 (2001)	6 at 151 (334)
Eaton 93PM IBC–SW with 1 battery string (40 batteries)	480V	1007 (2219)	980 (2159)	6 at 163 (360)
Eaton 93PM IBC–SW Shipped without batteries	432V	301 (665)		
Eaton 93PM IBC–SW Shipped without batteries	480V	303 (667)		

The IBC–SW uses natural convection cooling to regulate internal component temperature. Air inlets are in the front of the cabinet and outlets are on the back or top of the cabinet. Allow clearance in front of, and on back or top of the cabinet for proper air circulation. The clearances required around the IBC–SW cabinet are shown in [Table 2](#).

Table 2. IBC-SW Cabinet Clearances

From Top of Cabinet with Rear Exhaust Option	203.2 mm (8") minimum clearance
From Top of Cabinet with Top Exhaust Option	203.2 mm (8") minimum clearance
From Front of Cabinet	914.4 mm (36") working space
From Back of Cabinet with Top Exhaust Option	None Required
From Back of Cabinet with Rear Exhaust Option	203.2 mm (8") minimum clearance
From Right Side of Cabinet	None Required
From Left Side of Cabinet	None Required

Figure 3. Eaton 93PM Integrated Battery Cabinet–Small Welded Dimensions (Front, Right Side, and Rear Views)

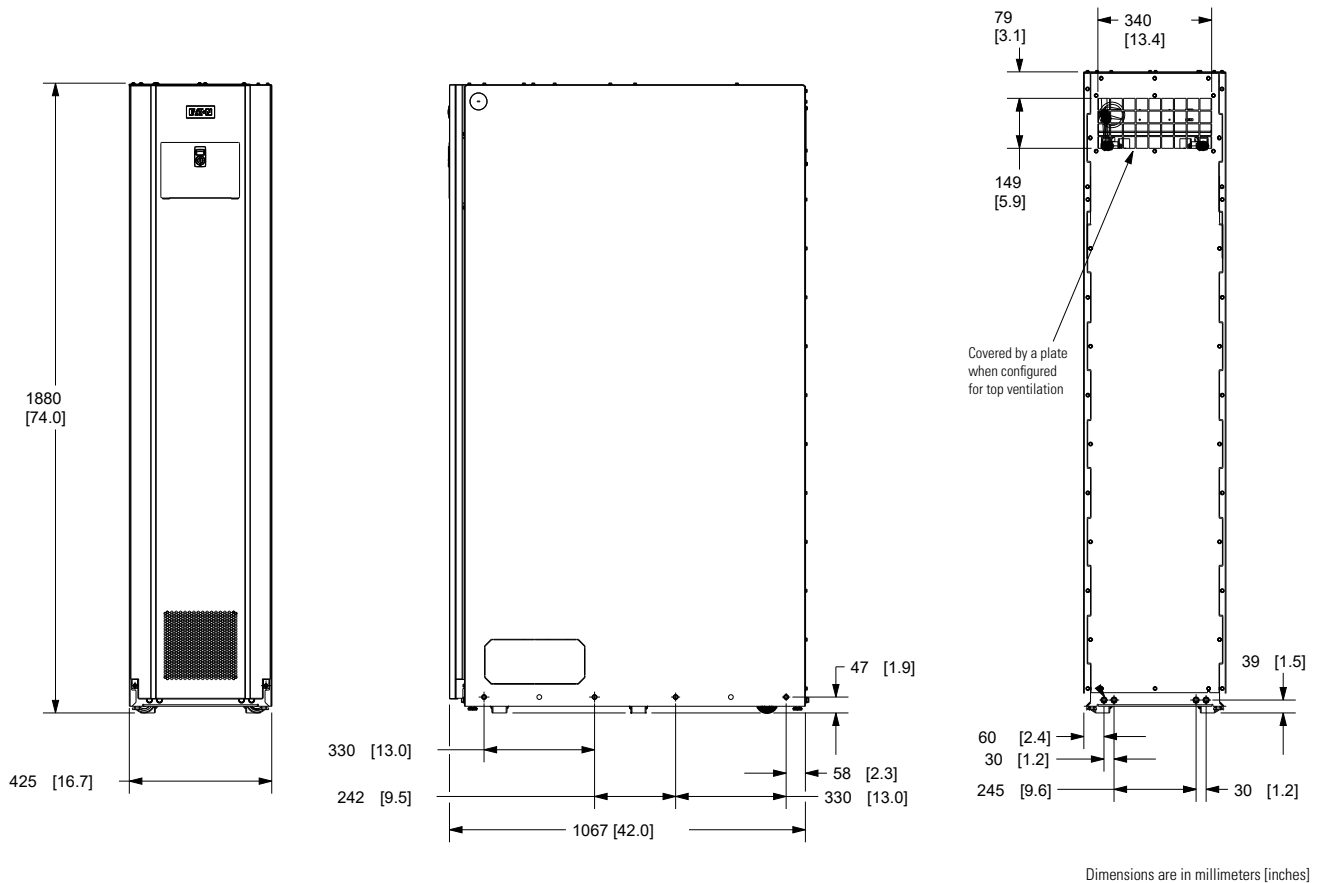
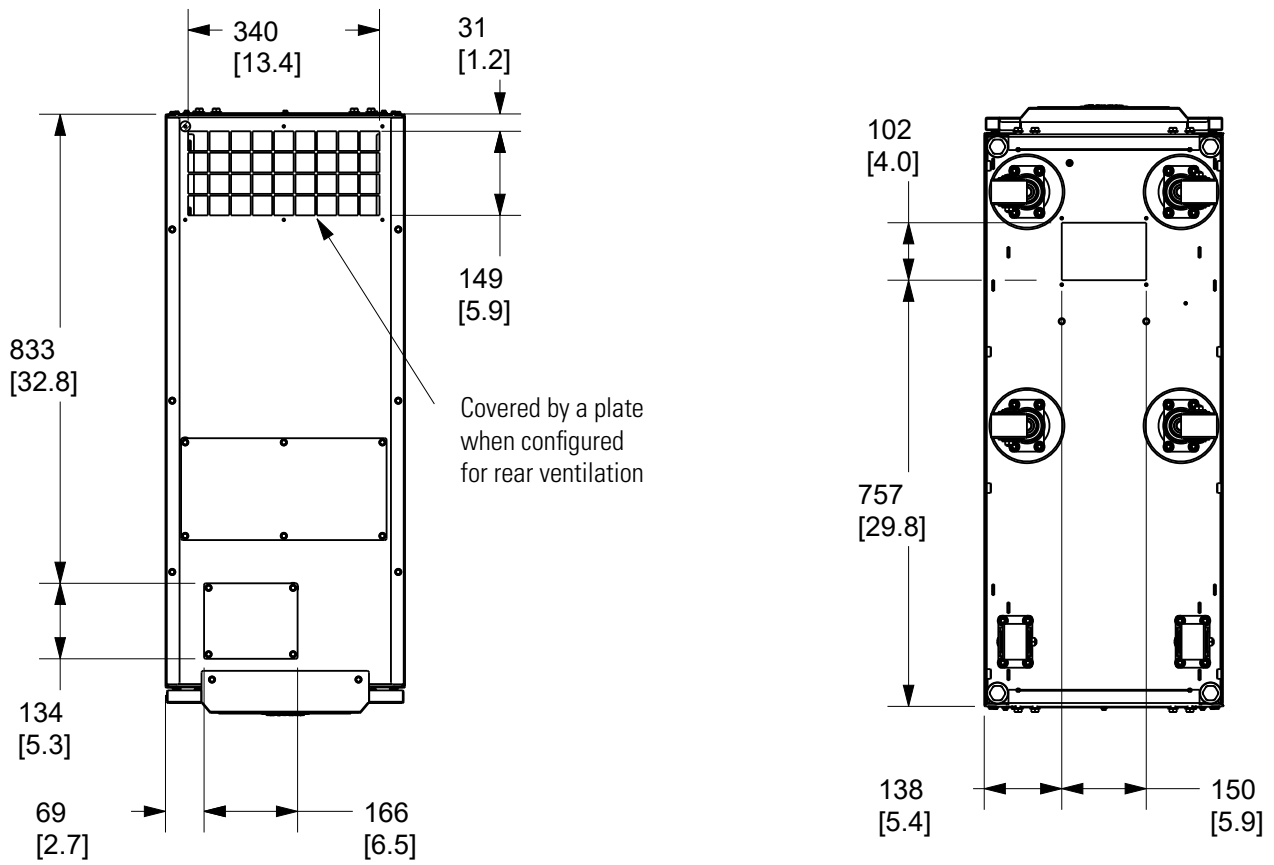
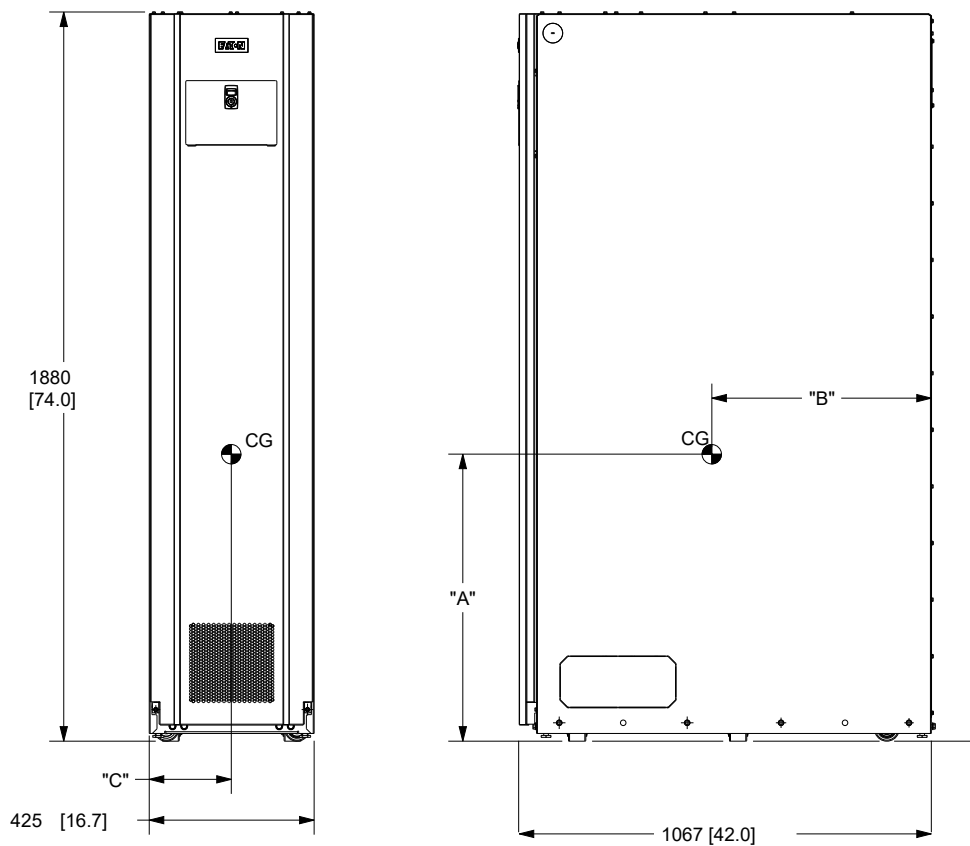

Figure 4. Eaton 93PM IBC-SW Dimensions (Top and Bottom Views)



Dimensions are in millimeters [inches]

Figure 5. Eaton 93PM IBC–SW Center of Gravity



Dimensions are in millimeters [inches]

Weight and Center of Gravity (letters A, B, and C map to Figure 5)					
	DC Voltage Output (Nominal)	A mm (in)	B mm (in)	C mm (in)	Weight kg (lb)
93PM IBC–SW with 1 String - 36 Batteries	432	833 [32.8]	527 [20.7]	213 [8.4]	907.9 [2001]
93PM IBC–SW with 1 String - 40 Batteries	480	872 [34.3]	507 [20.0]	213 [8.4]	979.5 [2159]
93PM IBC–SW with no batteries	432	899 [35.4]	542 [21.3]	214 [8.4]	274.3 [605]
93PM IBC–SW with no batteries	480	902 [35.5]	541 [21.3]	214 [8.4]	275.5 [607]

3.2.2 IBC–SW Power Wiring Preparation

Read and understand the following notes while planning and performing the installation:

 **WARNING**

As a result of the connected loads high leakage current is possible. Connection to earth ground is required for safety and proper product operation. Do not check IBC–SW operation by any action that includes removal of the earth (ground) connection with loads attached.

- Refer to national and local electrical codes for acceptable external wiring practices.
 - Material and labor for external wiring requirements are to be provided by the customer.
 - For external wiring, use only 75°C copper wire.
-

 **IMPORTANT**

This product has been evaluated for use with **copper wire only**.

Wire sizes listed in [Table 3](#) and [Table 4](#) are for copper wiring only. If wire is run in an ambient temperature greater than 40°C, higher temperature wire and/or larger size wire may be necessary. Wire sizes are based on using the specified breakers.

- Recommended wire sizes are based on NFPA National Electrical Code® (NEC®)70 Table 310.15(B)(16) 75° C ampacity with 40°C ambient correction factors.
- The battery wiring used between the battery and the UPS for standalone installations should be a maximum of 20 meters (65 feet) with a voltage drop of less than 1% of nominal DC voltage at rated battery current.
- Refer to NEC Article 250 and local codes for proper grounding practices.
- Battery voltage is computed at 2 volts per cell as defined by Article 480 of the NEC. Rated battery current is computed at 2 volts per cell.
- The battery cabinet frame is not referenced to the DC circuit.
- Each battery cabinet has its own overcurrent protection device.
- Internal battery strings are to be connected by an authorized Eaton Customer Service Engineer.
- Refer to the appropriate Eaton 93PM UPS Installation and Operation manual listed in paragraph [1.7 For More Information](#) for UPS cabinet conduit and terminal specifications and locations.
- The term line-up-and-match refers to accessory cabinets that are physically located adjacent to the UPS. The term standalone refers to accessory cabinets that are located separate from the UPS.

For line-up-and-match external power wiring requirements, including the minimum AWG size of external wiring, see [Table 3](#). For standalone external power wiring requirements, including the minimum AWG size of external wiring, see [Table 4](#). Wire sizes listed are for copper wiring only.

Table 3. Line-Up-and-Match External Power Wiring Recommendations: Eaton 93PM IBC-SW (432V or 480V)

Battery Cabinet to UPS				
UPS Frame	Minimum Number of Battery Cabinets	Terminal	Recommended Conductor Size (AWG or kcmil)	Number per Pole
50 kW	1	Battery (+)	Factory Supplied 2/0	1
100 kW	2	Battery (-)	Factory Supplied 2/0	1
150 kW	3			
200 kW	3	Ground	#4	one per cabinet



NOTE

Standalone IBC-SW installations with three or four IBC-SWs require a customer supplied external tie point and circuit breaker or disconnect between the IBC-SWs and the UPS.

Table 4. Standalone External Power Wiring Recommendations: Eaton 93PM IBC-SW (432V or 480V)

UPS Frame	Minimum Number of Battery Cabinets	Terminal	Battery Cabinet to UPS or External Customer Supplied Tie Point and Breaker or Disconnect		Tie Point and Breaker or Disconnect to UPS	
			Recommended Conductor Size (AWG or kcmil)	Number per Pole	Recommended Conductor Size (AWG or kcmil)	Number per Pole
50 kW	1	Battery (+)	2/0	2	Not Required	
100 kW	2	Battery (-)	2/0	2	Not Required	
150 kW	3	Battery (+)	2/0	2	2/0	2
200 kW	3	Battery (-)	2/0	2	2/0	2
		Ground	#4	one per cabinet	#4	one per cabinet

The power wiring terminals are pressure terminations, UL and CSA rated at 90°C. See [Table 5](#) for external power cable terminations.

[Figure 13](#) and [Figure 15](#) show the location of the IBC power cable terminals.

Table 5. External Power Cable Terminations for the Eaton 93PM IBC-SW

Model	Terminal Function	Terminal	Function	Number and Size of Pressure Termination	Tightening Torque Nm (lb in)	Screw Size and Type
IBC-SW	DC Output	Battery +	Positive	2 - #6-250 kcmil	31 (275)	5/16" Hex
		Battery -	Negative	2 - #6-250 kcmil	31 (275)	5/16" Hex
	Customer Ground	Ground	Ground	6 - #6-1/0	5.1 (45)	Slotted

NOTE Customer ground, sized in accordance with NEC Table 250.122, can be run in any conduit listed. Refer to the appropriate UPS manual.

External DC input overcurrent protection and disconnect switch for the remote battery location (three or four IBC-SWs) is to be provided by the customer. [Table 6](#) lists the maximum rating for continuous-duty rated circuit breakers satisfying the criteria for both.

Table 6. Recommended DC Circuit Breaker or Disconnect Ratings (Three or Four IBCs)

Model	UPS Model	Input Rating
IBC-SW	50 kW	250A
	100 kW	
	150 kW	
	200 kW	

3.2.3 IBC-SW Interface Wiring Preparation

Control wiring for features and options should be connected at the customer interface terminal blocks located inside the IBC-SW.



Do not directly connect relay contacts to the mains related circuits. Reinforced insulation to the mains is required.

Read and understand the following notes while planning and performing the installation:

- Use Class 1 wiring methods (as defined by the NEC) for interface wiring from 30V to 600V. The wire should be rated for 600V, 1A minimum. 12 AWG maximum wire size.
- Use Class 2 wiring methods (as defined by the NEC) for interface wiring up to 30V. The wire should be rated for 24V, 1A minimum.
- Because of the battery shunt trip wiring route in the 93PM UPS cabinet, the wiring from the IBC to the UPS must use wire rated for 600V and Class 1 wiring methods.
- The battery detect signal wiring from the battery cabinet must be connected to a programmed UPS building alarm.
- Battery detect and 48 Vdc shunt trip wiring should be a minimum of 18 AWG.
- Use twisted-pair wires for each input and return or common.
- All interface wiring and conduit is to be supplied by the customer.
- Interface wiring can be installed using the inter-cabinet wiring access pass-through or by routing wiring through conduit between cabinets.

- Install the interface wiring in separate conduit from the power wiring.

3.3 Inspecting and Unpacking the Eaton 93PM IBC–SW

The cabinet is shipped bolted to a metal and wood pallet (see [Figure 6](#)), and covered with outer protective packaging material.



NOTE

Startup and operational checks must be performed by an authorized Eaton Customer Service Engineer, or the warranty terms specified in [Chapter 8 Warranty](#) become void. This service is offered as part of the sales contract for the UPS. Contact an Eaton service representative in advance (usually a two-week notice is required) to reserve a preferred startup date.



WARNING

The IBC–SW is heavy (see [Table 1](#)). If unpacking and unloading instructions are not closely followed, the cabinet may tip and cause serious injury.

1. Carefully inspect the outer packaging for evidence of damage during transit.



CAUTION

Do not install a damaged cabinet. Report any damage to the carrier and contact an Eaton service representative immediately.



NOTE

For the following step, verify that the forklift or pallet jack is rated to handle the weight of the cabinet (see [Table 1](#) for cabinet weight).

2. Use a forklift or pallet jack to move the packaged cabinet to the installation site, or as close as possible, before unpacking. If possible, move the cabinet using the pallet. Insert the forklift or pallet jack forks between the supports on the bottom of the pallet. See [Figure 5](#) for the IBC–SW cabinet center of gravity measurements.
3. Set the pallet on a firm, level surface, allowing a minimum clearance of 3m (10 ft) on each side for removing the cabinet from the pallet
4. Remove the protective packaging material from the cabinet and recycle in a responsible manner. Retain the parts kit box packed at the top of the cabinet.
5. Inspect the contents for any evidence of physical damage, and compare each item with the Bill of Lading. If damage has occurred or shortages are evident, contact an Eaton service representative immediately to determine the extent of the damage and its impact on further installation.



NOTE

While waiting for installation, protect the unpacked cabinet from moisture, dust, and other harmful contaminants. Failure to store and protect the IBC properly may void the warranty.

Figure 6. Eaton 93PM IBC-SW as Shipped on Pallet

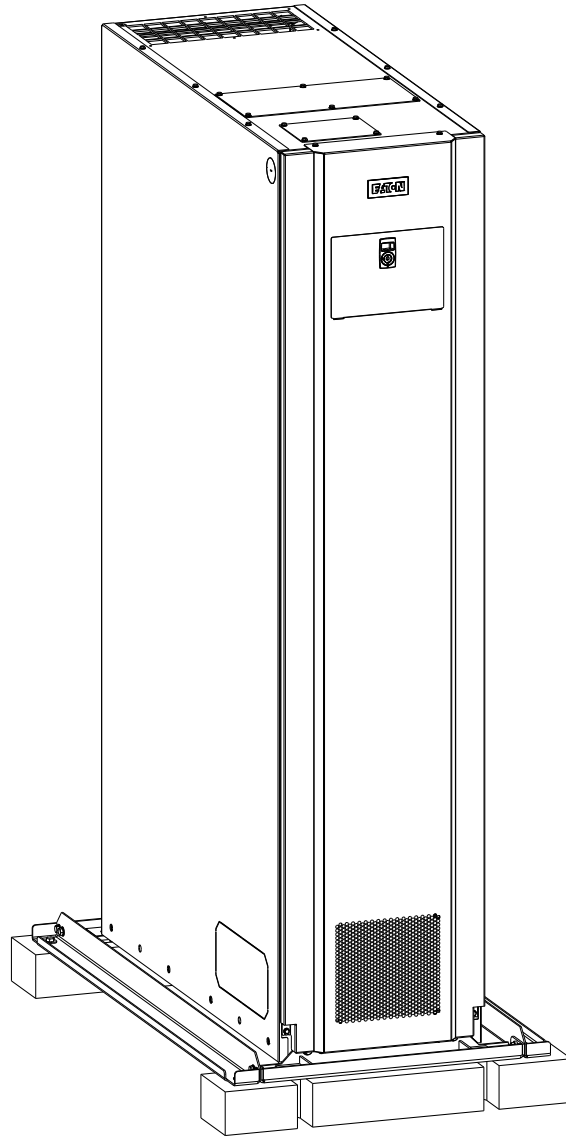

3.4 Battery Breaker Location

[Figure 7](#) shows the location of the battery breaker in the 93PM Integrated Battery Cabinet–Small Welded with the front cover removed.

Figure 7. Eaton 93PM IBC–SW Battery Breaker Locations – Front View with Cover Removed

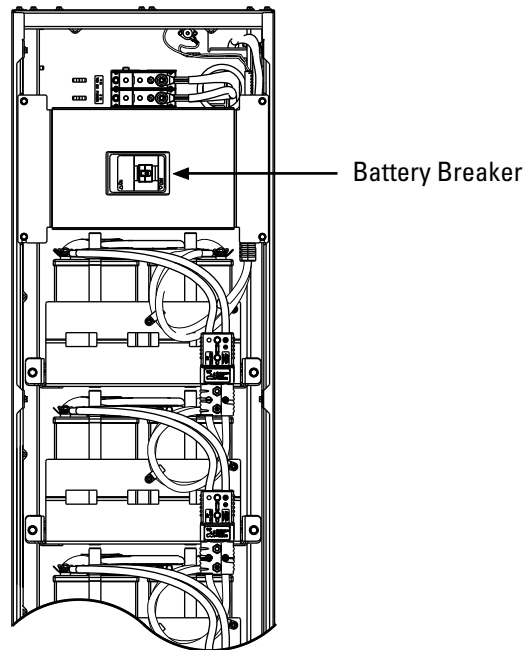

Chapter 4 Installation

4.1 Preliminary Installation Information

 **WARNING**

Installation should be performed only by qualified personnel knowledgeable of batteries and the required precautions.

Observe these precautions while installing the Integrated Battery Cabinet (IBC):

- Remove watches, rings, or other metal objects.
- Use tools with insulated handles.
- Wear voltage rated gloves and electrical hazard footwear.
- Do not lay tools or metal parts on top of batteries or battery cabinets.
- Refer to **Chapter 3 *Installation Plan and Unpacking*** for cabinet dimensions and weight, wiring and terminal data, and installation notes.
- Do not tilt the cabinets more than 10° during installation.

Failure to follow these instructions may result in severe injury or death.

4.2 Unloading the IBC Cabinet from the Pallet

 **DANGER**

RISK OF INSTABILITY. Do not remove any internal panels until the cabinet is removed from and lowered from the pallet.

 **WARNING**

- The IBC is heavy (see [Table 1](#)). If unpacking and unloading instructions are not closely followed, the cabinet may tip and cause serious injury or death.
- Lift the cabinets only with a forklift or pallet jack or damage may occur.
- Verify that the forklift or pallet jack is rated to handle the weight of the cabinet (see [Table 1](#) for cabinet weight).
- Do not tilt cabinet more than 10° from vertical.

Failure to follow these instructions may result in severe injury or death.

The IBC is bolted to a pallet consisting of four metal angle supports secured to two wood supports.

To remove the pallet:

 **CAUTION**

Do not use the jacking bolts on a soft surface floor. Use only on a hard surface, such as concrete. If necessary remove pallet on a hard surface and roll cabinet to final installation position.

1. If not already accomplished, use a forklift or pallet jack to move the IBC to the installation area, or as close as possible, before unloading from the pallet. Insert the forklift or pallet jack forks between the supports on the bottom of the pallet (see [Figure 5](#) for the IBC cabinet center of gravity measurements).

2. Remove the front cover by loosening the left and right side bottom mounting bolts and remove the two mounting bolts on the top. Lift the cover to disengage the cover from the bottom bolts then set the cover to the side in a safe location. Retain the hardware for later use.
3. Locate the four 1/2" jacking bolts from the parts bag packed inside the front cover and install them in the threaded holes in the front and rear supports as shown in [Figure 8](#). Place a floor protector from the parts kit underneath each jacking bolt, and screw the bolts down against them.

The floor protectors protect the floor from being marred by the jacking bolts.



WARNING

Do not remove or loosen the cabinet mounting or cabinet support bolts until instructed.

4. Loosen, but do not remove, the skid mounting bolts holding the front and rear supports to the pallet skids.



WARNING

RISK OF INSTABILITY. Turning the jacking bolts unevenly may cause the cabinet to become unbalanced. To prevent tipping the cabinet, raise the cabinet no more than 3 mm (1/8") above the floor (just enough to allow the removal of the pallet skids). Failure to follow these instructions can result in serious injury or death.

5. Turn each jacking bolt consecutively, two full turns, until the pallet skids clear the floor by approximately 3 mm (1/8").
6. Remove the hardware loosened in **Step 4**.
7. Pull the pallet skids out from under the metal angle supports without disturbing the jacking bolts. Recycle the pallet skids and hardware in a responsible manner.



CAUTION

CABINET MAY FALL. Do not loosen the hardware attaching the front supports to the cabinet base. The cabinet must be lowered by the jacking bolts before the supports can be removed.

8. Carefully and evenly **lower the cabinet by turning each jacking bolt consecutively two full turns (maximum)** until the casters contact the floor and the cabinet is no longer supported by the jacking bolts.
9. After the IBC is resting on the floor, remove the jacking bolts and floor protectors. Recycle them in a responsible manner.

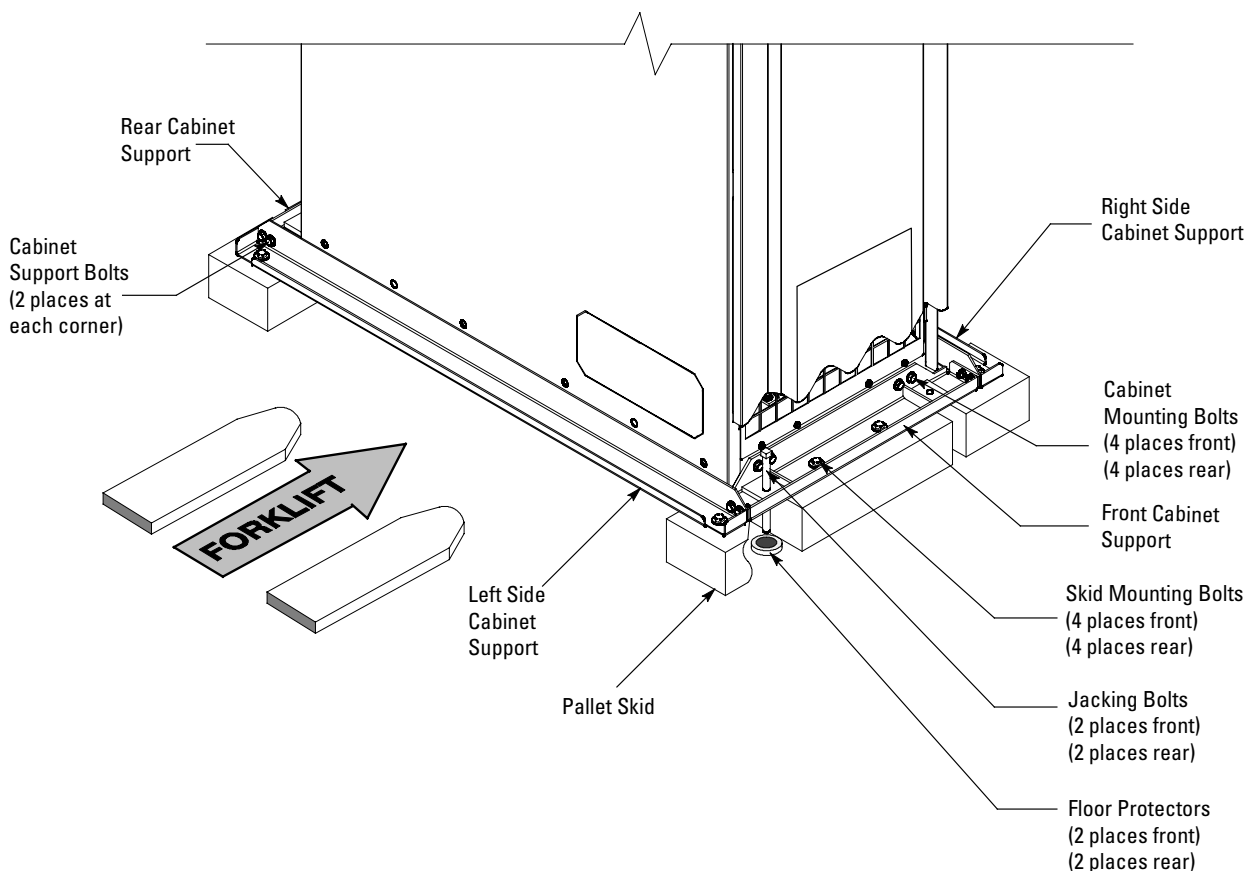
Figure 8. Removing the Pallet Skids and Supports – Eaton 93PM Integrated Battery Cabinet

10. Remove the cabinet support bolts fastening the front, rear, and side cabinet supports together and remove the side supports.
11. Remove the cabinet mounting bolts holding the front and rear supports to the cabinet base and remove the supports.
12. If installing the cabinet permanently (requires the optional Floor Mount Bracket Kit), retain the cabinet mounting bolts; otherwise, recycle the bolts along with the support brackets in a responsible manner.
13. If the leveling feet are not retracted, turn all four leveling feet until they are retracted as far into the cabinet as possible.

**NOTE**

The battery cabinet may be located to either the right or left of the UPS cabinet. This procedure assumes the battery cabinet is located to the right of the UPS cabinet.

14. If line-up-and-match installation, remove the rectangular and circular knockout on the bottom and top front side of the UPS and the IBC-SW (see [Figure 9](#)).
15. The IBC-SW is shipped set up for rear ventilation with a cover plate installed over the ventilation grill on top of the unit (see [Figure 10](#)). If top ventilation is required, remove the screws securing the plate at the top of the unit and install the plate over the rear ventilation grill (see [Figure 11](#)).

 **CAUTION**

To prevent tipping when rolling the cabinet, push the cabinet from the rear whenever possible.

16. Roll the IBC–SW to the line-up-and-match installation location on the side of the UPS cabinet making sure the covers are flush with each other or to the standalone installation location.
 17. Lower the cabinet's leveling feet and using a bubble level, adjust the leveling feet accordingly until the cabinet is level.
 18. Locate the top splice bracket shipped with the IBC.
 19. Remove the screws along each adjacent cabinet top panel securing the top panels. Retain the hardware for later use.
 20. Install the top splice bracket between the adjacent cabinet and secure the tie strap with retained hardware.
 21. If permanently mounting the IBC (requires the optional Floor Mount Bracket Kit), continue to **Step 22**; otherwise, proceed to **Step 25**.
 22. Locate the two floor mounting brackets from the Floor Mount Bracket kit.
 23. Using the retained cabinet mounting bolts, install the floor mounting brackets to the front and rear of the IBC with the angle facing outward.
 24. Secure the cabinet to the floor with customer-supplied hardware.
-



NOTE

In standalone configurations, multiple IBCs are installed adjacent to each other, but separate from the UPS.

25. If installing more than one IBC, remove the rectangular knockouts on the bottom front sides the IBCs (see [Figure 9](#)) and repeat **Steps 1** through **24**; otherwise, proceed to **Step 26**.
Install additional IBCs on the right or left side of the first IBC.
26. Proceed to paragraph [4.3 Installing Power Wiring](#).

Figure 9. Line-Up-and-Match Wiring Access Locations

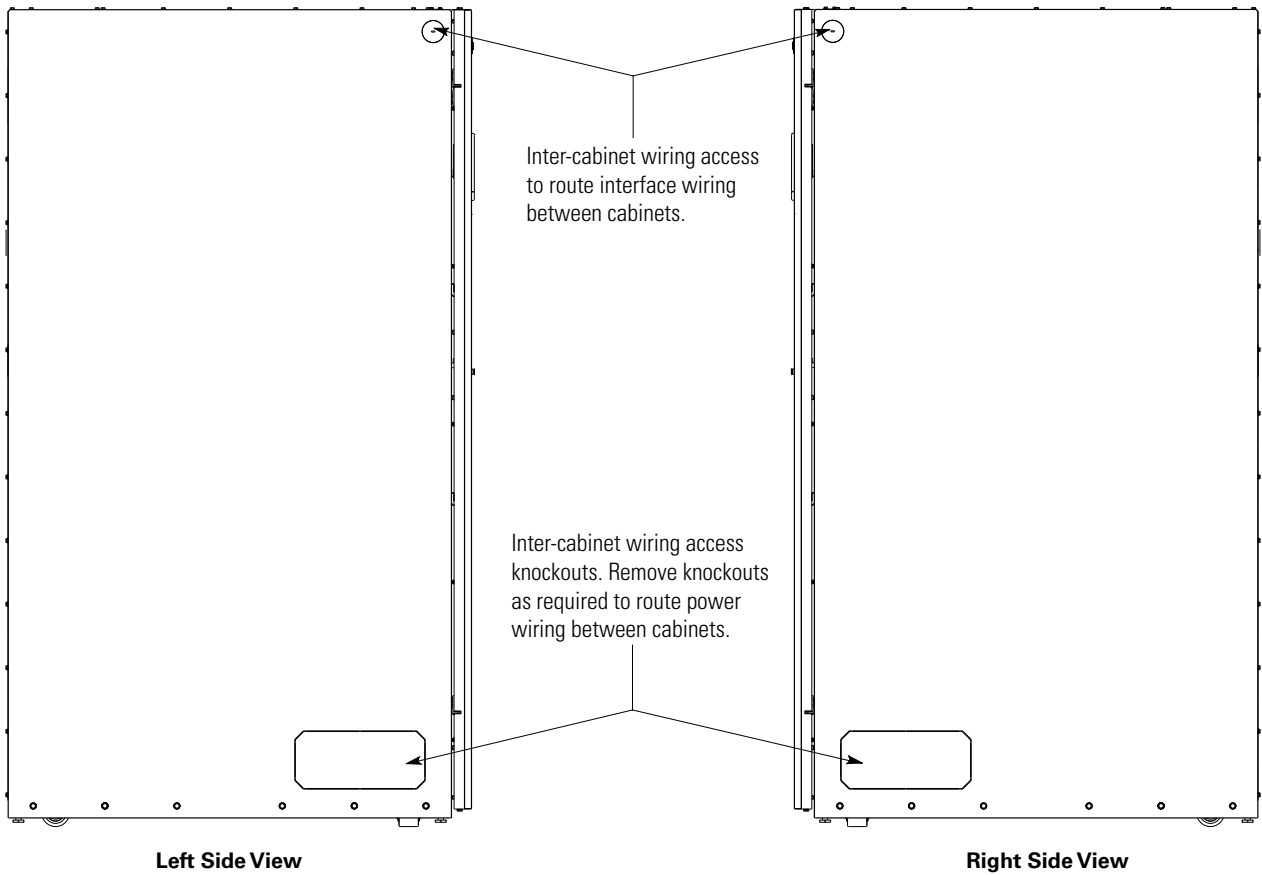

Figure 10. Rear Ventilation

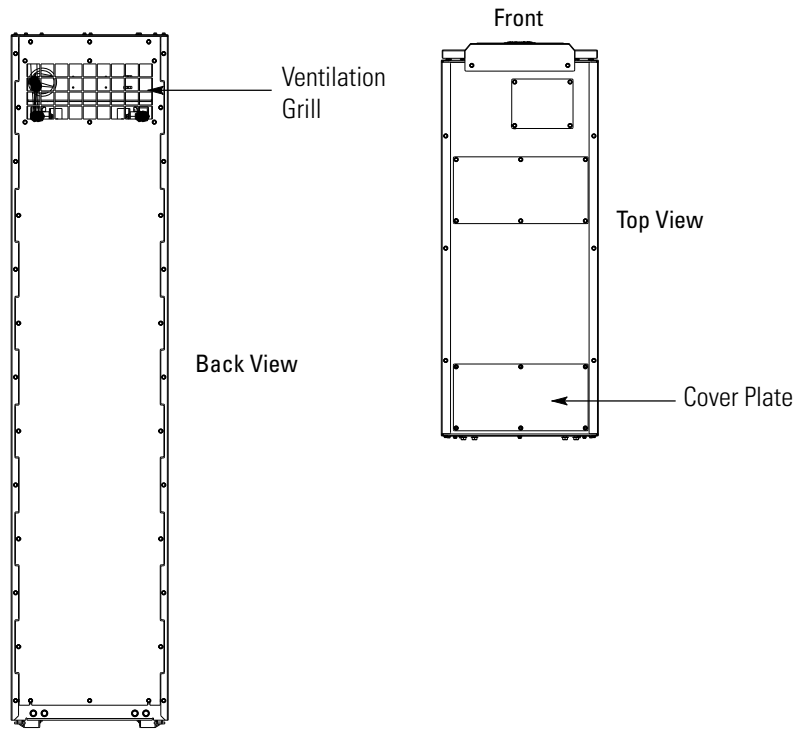
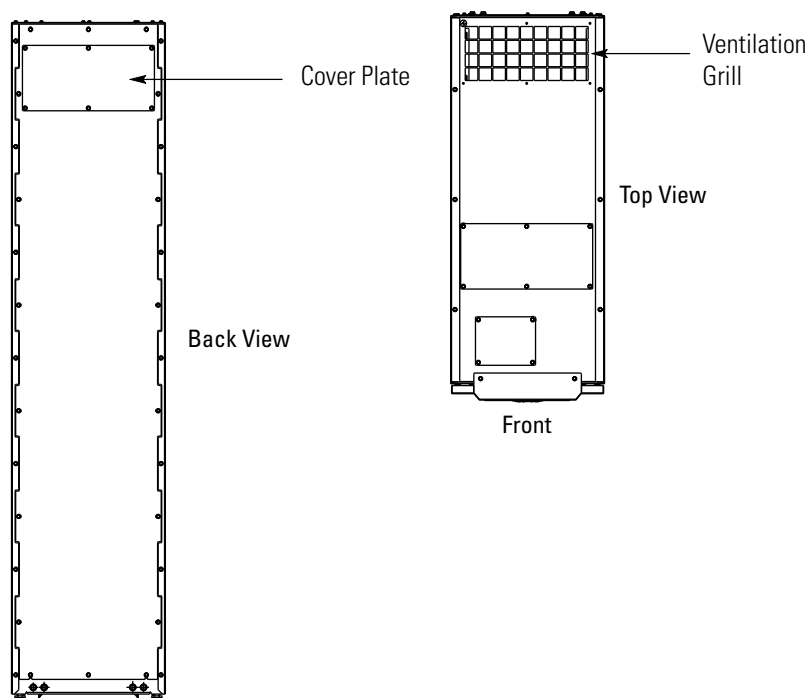

Figure 11. Top Ventilation

4.3 Installing Power Wiring

IBC–SWs can be installed in a line-up-and-match configuration with the power wiring routed through the IBC–SWs and UPS cabinet or in a standalone configuration with the power wiring routed between the IBC–SWs and the UPS cabinet using conduit. Use the appropriate procedure for the type of installation being wired.



IMPORTANT

This product has been evaluated for use with **copper wire only**. For external wiring, use only 75°C copper wire.

4.3.1 Line-Up-and-Match Power Wiring



NOTE 1 Each battery cabinet will be directly connected to the UPS and not daisy-chained between cabinets. All power wiring between the IBC–SWs and the UPS is factory supplied.



NOTE 2 Up to four IBC–SWs can be installed in a line-up-and-match configuration.

Use this procedure to wire line-up-and-match 93PM Integrated Battery Cabinets to the 93PM UPS cabinet.

To install wiring to connections:

1. Verify the UPS system is turned off and all power sources are removed. Refer to the applicable Eaton 93PM UPS Installation and Operation manual, listed in paragraph [1.7 For More Information](#), for UPS operating procedures.

2. If not already removed, remove the front cover by loosening the left and right side bottom mounting bolts and remove the two mounting bolts on the top. Lift the cover to disengage the cover from the bottom bolts then set the cover to the side in a safe location. Retain the hardware for later use.
3. Remove the screws securing the internal safety shield panel and remove the panel to gain access to the battery power terminals. Retain the hardware for later use.

-
-  **NOTE 1** Line-up-and-match positive and negative battery wiring is factory supplied coiled inside the IBC-SW.
-  **NOTE 2** Ferrules are installed on the ends of the factory supplied wiring. Do not shorten or cut factory supplied wiring.
-

4. Route the battery wiring (positive and negative) from the UPS DC Input terminals through the bottom side inter-cabinet access pass-through (see [Figure 9](#)) of the UPS cabinet and IBC-SW to the wiring channel on the left side of the IBC-SW (see [Figure 12](#)). Route the wiring along the wiring channel to the IBC-SW DC Output terminal block. See [Figure 13](#) for terminal locations. See paragraph [3.2.2 IBC-SW Power Wiring Preparation](#) and [Table 3](#) for wiring requirements. Refer to the applicable Eaton 93PM UPS Installation and Operation manual listed in paragraph [1.7 For More Information](#), for UPS cabinet terminal locations.
5. Secure the battery wiring to the wire tie anchors (see [Figure 14](#)) using Zip ties.
6. Route the battery cabinet ground wiring from the UPS through the bottom side inter-cabinet access pass-through (see [4.3.1 Line-Up-and-Match Power Wiring](#)) of the UPS cabinet and IBC-SW to the IBC-SW ground terminal block. See [Figure 13](#) for terminal location. See paragraph [3.2.2 IBC-SW Power Wiring Preparation](#) and [Table 3](#) for wiring requirements.

 **WARNING**

Verify polarity of connections. Risk of personal injury and damage to equipment from arc flash if connections are reversed.

7. Connect the positive and negative power wiring to the IBC-SW DC (+) and IBC-SW DC (-) output terminals. Connect the ground wiring to the IBC-SW ground terminal. See [Table 5](#) for termination requirements.
For a detailed view of the IBC-SW terminal block, see [Figure 15](#).
8. Connect the positive, negative, and ground power wiring from the IBC-SW to the UPS cabinet external battery input and ground terminals. Refer to the applicable Eaton 93PM UPS Installation and Operation manual listed in paragraph [1.7 For More Information](#), for UPS cabinet termination requirements.

-
-  **NOTE** Route the battery wiring between the UPS and subsequent IBC-SWs through the bottom of the adjacent IBC-SW.
-

9. If installing more than one IBC-SW, repeat **Steps 2** through **8** for each IBC-SW, and then proceed to paragraph [4.4 Installing IBC-SW Interface Wiring](#); otherwise, proceed to paragraph [4.4 Installing IBC-SW Interface Wiring](#).

-
-  **NOTE** The internal battery string is to be connected by an authorized Eaton Customer Service Engineer at system startup.
-

Figure 12. Wiring Channel Location

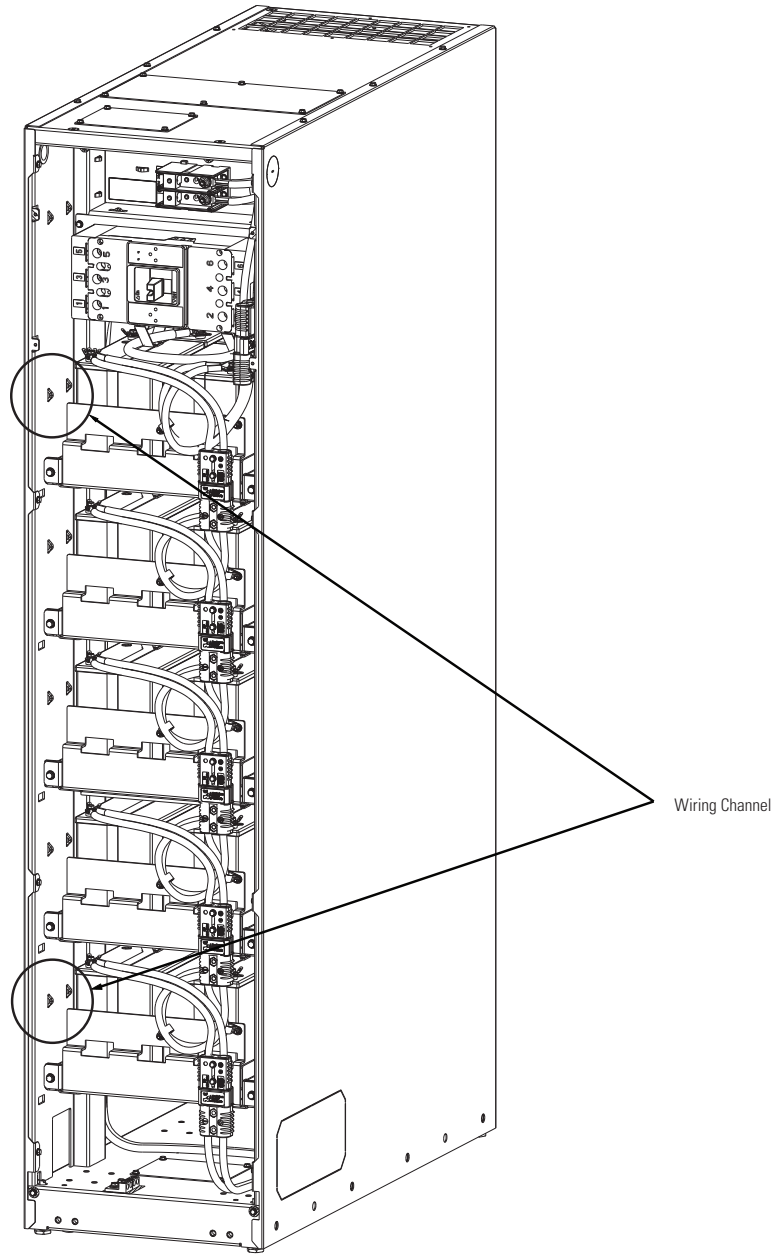

Figure 13. DC Power Terminal Locations – Eaton 93PM IBC–SW

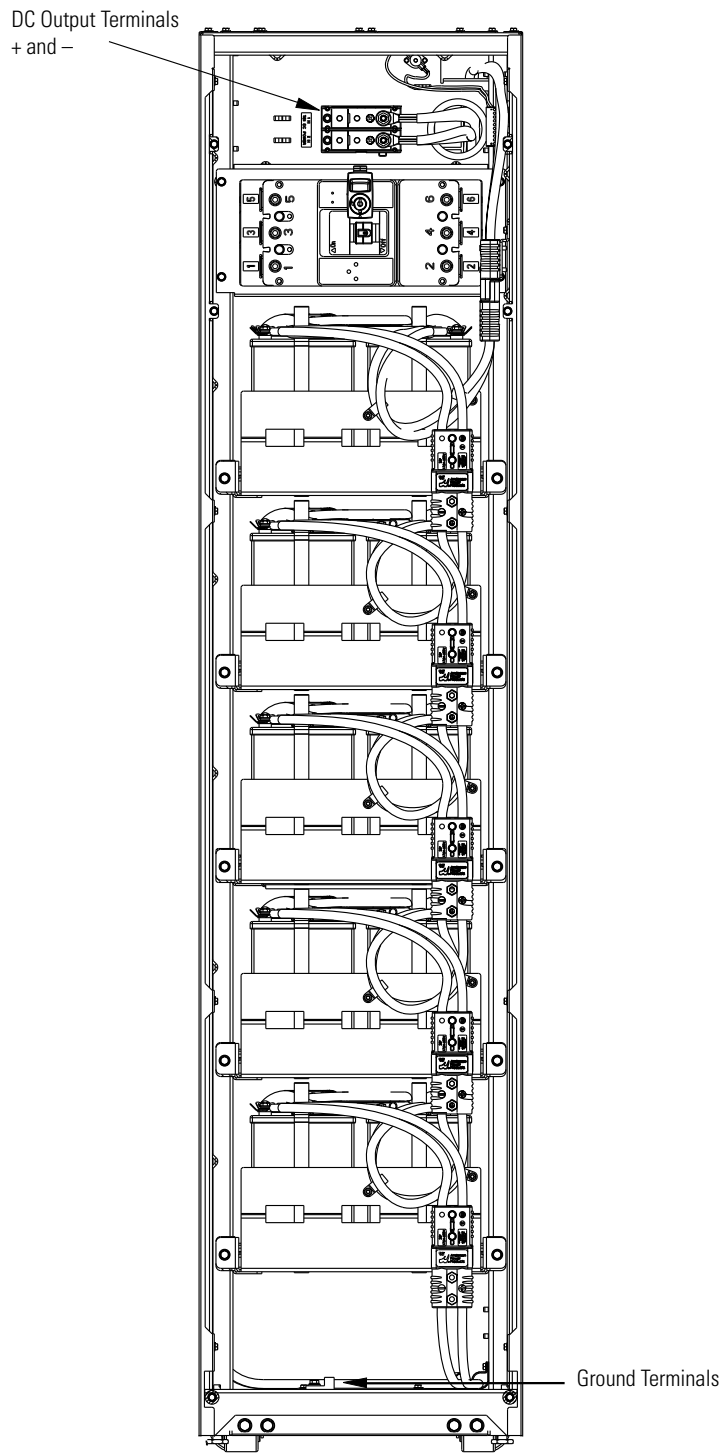

Figure 14. Wire Tie Anchors

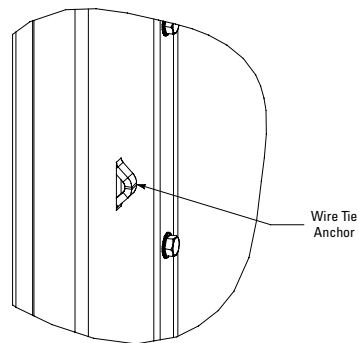
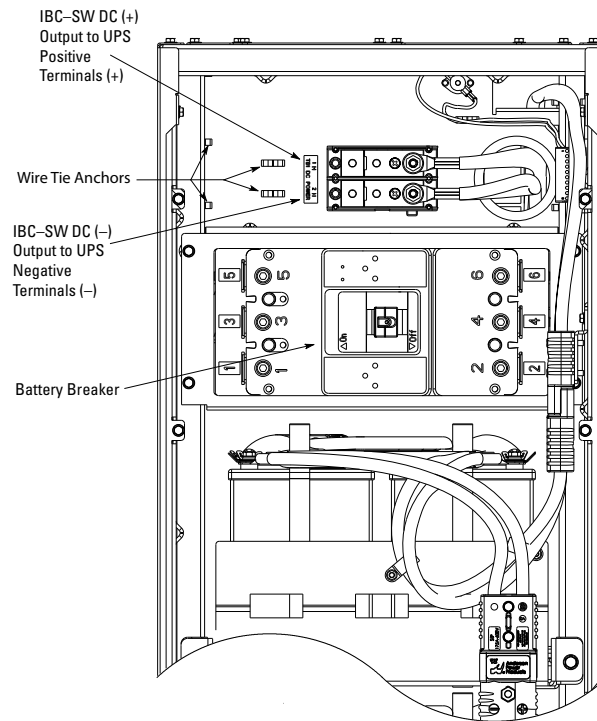

Figure 15. DC Power Terminal Detail – Eaton 93PM IBC-SW



4.3.2 Standalone Power Wiring

-
- NOTE 1** Each battery cabinet will be directly connected to the UPS and not daisy-chained between cabinets.
 - NOTE 2** Standalone IBC installations with three or four IBCs require a customer supplied external tie point and circuit breaker or disconnect between the IBCs and the UPS.
 - i** **NOTE 3** Up to four IBCs can be installed in a standalone configuration.
 - NOTE 4** In multiple IBC installations, individual conduit will be run between each battery cabinet and the UPS or disconnect. **DO NOT** run battery wiring from subsequent IBCs through the bottom of the adjacent IBCs.
 - NOTE 5** Remove the IBC conduit landing plates to drill or punch conduit holes, or remove knockouts in the conduit plate.
-

Use this procedure to wire standalone 93PM Integrated Battery Cabinets to the 93PM UPS cabinet.

To install wiring to connections:

1. Verify the UPS system is turned off and all power sources are removed. Refer to the applicable Eaton 93PM UPS Installation and Operation manual, listed in paragraph [1.7 For More Information](#), for UPS operating procedures.
2. If not already removed, remove the front cover by loosening the left and right side bottom mounting bolts and remove the two mounting bolts on the top. Lift the cover to disengage the cover from the bottom bolts then set the cover to the side in a safe location. Retain the hardware for later use.
3. Remove the screws securing the internal safety shield panel and remove the panel to gain access to the battery power terminals. Retain the hardware for later use.
4. If wiring the IBC–SW using the top entry access, continue to **Step 5**; if using bottom entry access, proceed to **Step 13**.
5. **Top Entry Wiring.** Remove the top conduit plate (see [Figure 16](#)) from the top of the IBC–SW. Identify all conduit requirements and mark their location. Drill and punch all conduit holes in the top conduit plate prior to mounting on the IBC–SW. Install the conduit plate and install all conduit runs into the plate. Pull the wiring through the conduit into the wiring area.
Note: Power and Interface wiring share the same conduit plate.
6. Route the battery wiring (positive and negative) from the UPS DC Input terminals or DC disconnect tie point through top of the IBC–SW to the IBC–SW DC Output terminal block. See [Figure 13](#) for terminal locations. See paragraph [3.2.2 IBC–SW Power Wiring Preparation](#) and [Table 4](#) for wiring requirements. Refer to the applicable Eaton 93PM UPS Installation and Operation manual listed in paragraph [1.7 For More Information](#), for UPS cabinet terminal locations.
7. Route the battery cabinet ground wiring from the UPS through the top of the IBC–SW to the wiring channel on the left side of the IBC–SW (see [Figure 12](#)). Route the wiring along the wiring channel to the IBC–SW ground terminal block. See [Figure 13](#) for terminal location. See paragraph [3.2.2 IBC–SW Power Wiring Preparation](#) and [Table 4](#) for wiring requirements.
8. Secure the ground wiring to the wire tie anchors (see [Figure 14](#)) using Zip ties.
9. Connect the positive and negative power wiring to the IBC–SW DC (+) and DC (–) output terminals. Connect the ground wiring to the IBC–SW ground terminal. See paragraph [3.2.2 IBC–SW Power Wiring Preparation](#) and [Table 4](#) for termination requirements.
10. Connect the positive, negative, and ground DC power wiring from the IBC–SW or disconnect to the UPS cabinet battery and ground terminals. Refer to the applicable Eaton 93PM UPS Installation and Operation manual listed in paragraph [1.7 For More Information](#), for UPS cabinet termination requirements.

11. Secure the positive, negative, and ground DC power wiring to the wire tie anchors (see [Figure 14](#)) using Zip ties.

**NOTE**

If installing more than one IBC–SW, individual conduit will be run between each battery cabinet and the UPS or disconnect. **DO NOT** run battery wiring from subsequent IBC–SWs through the bottom of the adjacent IBC–SWs.

12. If installing more than one IBC–SW, repeat **Steps 2** through **11** for each IBC–SW, and then proceed to paragraph [4.4 Installing IBC–SW Interface Wiring](#); otherwise, proceed to paragraph [4.4 Installing IBC–SW Interface Wiring](#).

**NOTE**

The internal battery string is to be connected by an authorized Eaton Customer Service Engineer at system startup.

13. **Bottom Entry Wiring.** Remove the bottom conduit plate (see [Figure 16](#)) from the inside bottom of the IBC–SW. Identify all conduit requirements and mark their location. Drill and punch all conduit holes in the bottom conduit plate prior to mounting on the IBC–SW. Install the conduit plate and install all conduit runs into the plate. Pull the wiring through the conduit into the wiring areas.

Note: Power and Interface wiring share the same conduit plate.

14. Route the battery wiring (positive and negative) from the UPS DC Input terminals or DC disconnect tie point through the bottom of the IBC–SW to the wiring channel on the left side of the IBC–SW (see [Figure 12](#)). Route the wiring along the wiring channel to the IBC–SW DC Output terminal block. See [Figure 13](#) for terminal locations. See paragraph [3.2.2 IBC–SW Power Wiring Preparation](#) and [Table 4](#) for wiring requirements. Refer to the applicable Eaton 93PM UPS Installation and Operation manual listed in paragraph [1.7 For More Information](#), for UPS cabinet terminal locations.
15. Secure the battery wiring to the wire tie anchors (see [Figure 14](#)) using Zip ties.
16. Route the battery cabinet ground wiring from the UPS through the bottom of the IBC–SW to the IBC–SW ground terminal block. See [Figure 13](#) for terminal location. See paragraph [3.2.2 IBC–SW Power Wiring Preparation](#) and [Table 3](#) for wiring requirements.
17. Connect the positive and negative power wiring to the IBC–SW DC (+) and DC (–) output terminals. Connect the ground wiring to the ground terminal on the IBC–SW. See paragraph [3.2.2 IBC–SW Power Wiring Preparation](#) and [Table 4](#) for termination requirements.
For a detailed view of the IBC–SW terminal block, see .
18. Connect the positive, negative, and ground DC power wiring from the IBC–SW or disconnect to the UPS cabinet battery and ground terminals. Refer to the applicable Eaton 93PM UPS Installation and Operation manual listed in paragraph [1.7 For More Information](#), for UPS cabinet termination requirements.
19. Secure the positive, negative, and ground DC power wiring to the wire tie anchors (see [Figure 14](#)) using Zip ties.

**NOTE**

If installing more than one IBC–SW, individual conduit will be run between each battery cabinet and the UPS or disconnect. **DO NOT** run battery wiring from subsequent IBC–SWs through the bottom of the adjacent IBC–SWs.

20. If installing more than one IBC–SW, repeat **Steps 13** through **19** for each IBC–SW, and then proceed to paragraph [4.4 Installing IBC–SW Interface Wiring](#); otherwise, proceed to paragraph [4.4 Installing IBC–SW Interface Wiring](#).

**NOTE**

The internal battery string is to be connected by an authorized Eaton Customer Service Engineer at system startup.

Figure 16. Top and Bottom Entry Conduit and Wire Entry Locations

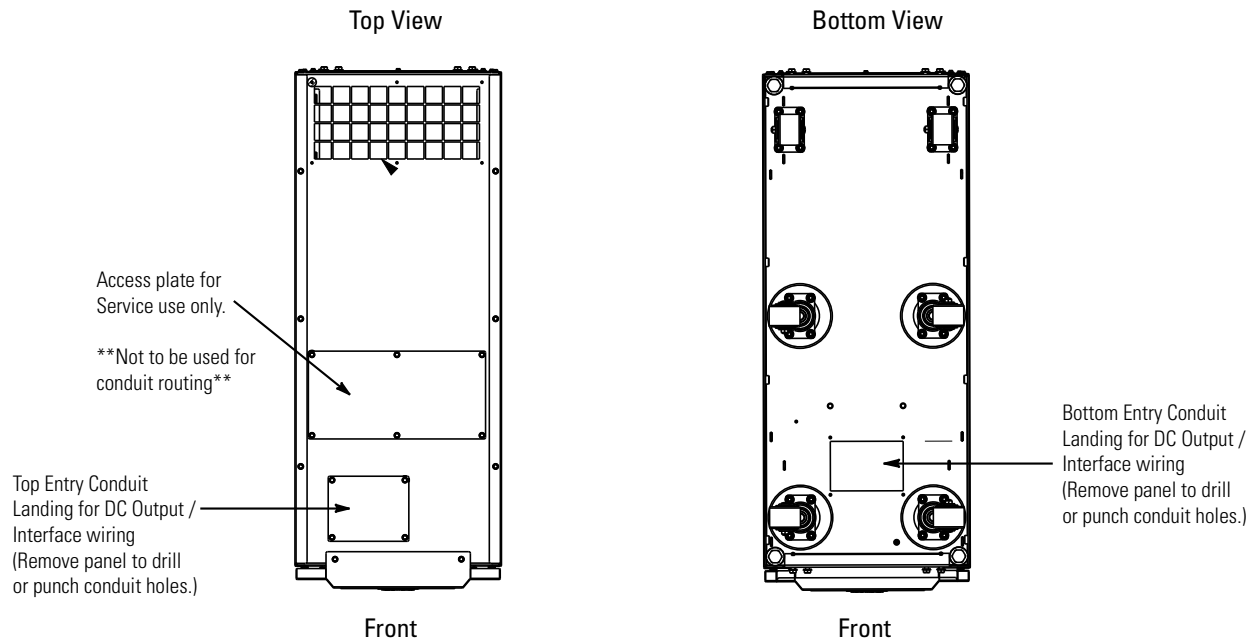

4.4 Installing IBC–SW Interface Wiring

IBC–SWs can be installed in a line-up-and-match configuration with the interface wiring routed through the IBC–SWs and UPS cabinet or in a standalone configuration with the interface wiring routed between the IBC–SWs and the UPS cabinet using conduit.

4.4.1 Installing Battery Detect Interface Connections

NOTE 1 Disconnect terminal block plug from terminal block to wire plug.



NOTE 2 If the inter-cabinet wiring access pass-through is not used to install the battery detect interface wiring connections, conduit must be installed between the battery cabinet and the UPS cabinet.

To install wiring:

1. If wiring the IBC–SW battery detect interface terminals using line-up-and-match wiring using the inter-cabinet wiring access pass-through (see [Figure 9](#)) continue to **Step 2**; if wiring the IBC–SW battery detect interface terminals using the top entry access, proceed to **Step 5**; if wiring the IBC–SW battery detect interface terminals using the bottom entry access, proceed to **Step 8**.



NOTE In multiple IBC–SW installations, route the battery interface wiring between IBC–SWs through the top of the adjacent IBC–SW using the top side inter-cabinet access pass-through (see [Figure 9](#)).

2. **Line-Up-and-Match Wiring.** Route the battery detect interface wiring from the UPS battery detect interface terminals through the top inter-cabinet access pass-through (see [Figure 9](#)) of the UPS cabinet and IBC–SW to the IBC–SW battery interface terminal block TB2. See [Figure 17](#) for terminal locations. See paragraph [3.2.3 IBC–SW Interface Wiring Preparation, Table 7](#), and [Figure 18](#) for wiring and termination requirements. Refer to the applicable Eaton 93PM UPS Installation and Operation manual listed in paragraph [1.7 For More Information](#), for UPS cabinet terminal locations.
3. Proceed to **Step 10**.
4. **Top Entry Wiring.** Remove the top conduit plate (see [Figure 16](#)) from the top of the IBC–SW. Identify all conduit requirements and mark their location. Drill and punch all conduit holes in the top conduit plate prior to mounting on the IBC–SW. Install the conduit plate and install all conduit runs into the plate. Pull the wiring through the conduit into the wiring area.

NOTE In multiple IBC–SW installations, route the battery interface wiring between IBC–SWs through the top of the adjacent IBC–SW using the top side inter-cabinet access pass-through (see [Figure 9](#)).

5. Route the battery detect interface wiring from the UPS battery detect interface terminals through top of the IBC–SW to the IBC–SW battery interface terminal block TB2. See [Figure 17](#) for terminal locations. See paragraph [3.2.3 IBC–SW Interface Wiring Preparation, Table 7](#), and [Figure 18](#) for wiring and termination requirements. Refer to the applicable Eaton 93PM UPS Installation and Operation manual listed in paragraph [1.7 For More Information](#), for UPS cabinet terminal locations.
6. Proceed to **Step 10**.
7. **Bottom Entry Wiring.** Remove the bottom conduit plate (see [Figure 16](#)) from the inside bottom of the IBC–SW. Identify all conduit requirements and mark their location. Drill and punch all conduit holes in the bottom conduit plate prior to mounting on the IBC–SW. Install the conduit plate and install all conduit runs into the plate. Pull the wiring through the conduit into the wiring areas.

NOTE In multiple IBC–SW installations, route the battery interface wiring between IBC–SWs through the top of the adjacent IBC–SW using the top side inter-cabinet access pass-through (see [Figure 9](#)).

8. Route the battery detect interface wiring from the UPS battery detect interface terminals through the bottom of the IBC–SW to the wiring channel on the left side of the IBC–SW (see [Figure 12](#)). Route the wiring along the wiring channel to the IBC–SW battery interface terminal block TB2. See [Figure 17](#) for terminal locations. See paragraph [3.2.3 IBC–SW Interface Wiring Preparation, Table 7](#), and [Figure 18](#) for wiring and termination requirements. Refer to the applicable Eaton 93PM UPS Installation and Operation manual listed in paragraph [1.7 For More Information](#), for UPS cabinet terminal locations.
9. Secure the interface wiring to the wire tie anchors (see [Figure 14](#)) using Zip ties.
10. Connect the battery detect interface wiring to the IBC–SW battery detect interface terminals. See paragraph [3.2.3 IBC–SW Interface Wiring Preparation](#) and [Table 8](#) for termination requirements.
For a detailed view of the IBC–SW terminal block, see [Figure 19](#).
11. Connect the battery detect interface wiring to the UPS battery detect interface terminals. Refer to the applicable Eaton 93PM UPS Installation and Operation manual listed in paragraph [1.7 For More Information](#), for UPS cabinet termination requirements.

NOTE In the following step, if the safety shield cannot be reinstalled because of misalignment, use the leveling feet to realign the cabinet.

12. Reinstall the internal safety shield panel removed in **Step 3** of paragraph [4.3.1 Line-Up-and-Match Power Wiring](#).

13. Install the front cover (previously removed) by carefully lowering the cover onto the bottom mounting bolts. Secure the top of the cover with the two retained mounting bolts and tighten the bottom bolts.
14. Once the battery cabinets are installed and wired, return to the applicable Eaton 93PM UPS Installation and Operation manual, listed in paragraph [1.7 For More Information](#), to complete the UPS wiring.

Figure 17. Interface Terminal Locations – Eaton 93PM IBC–SW

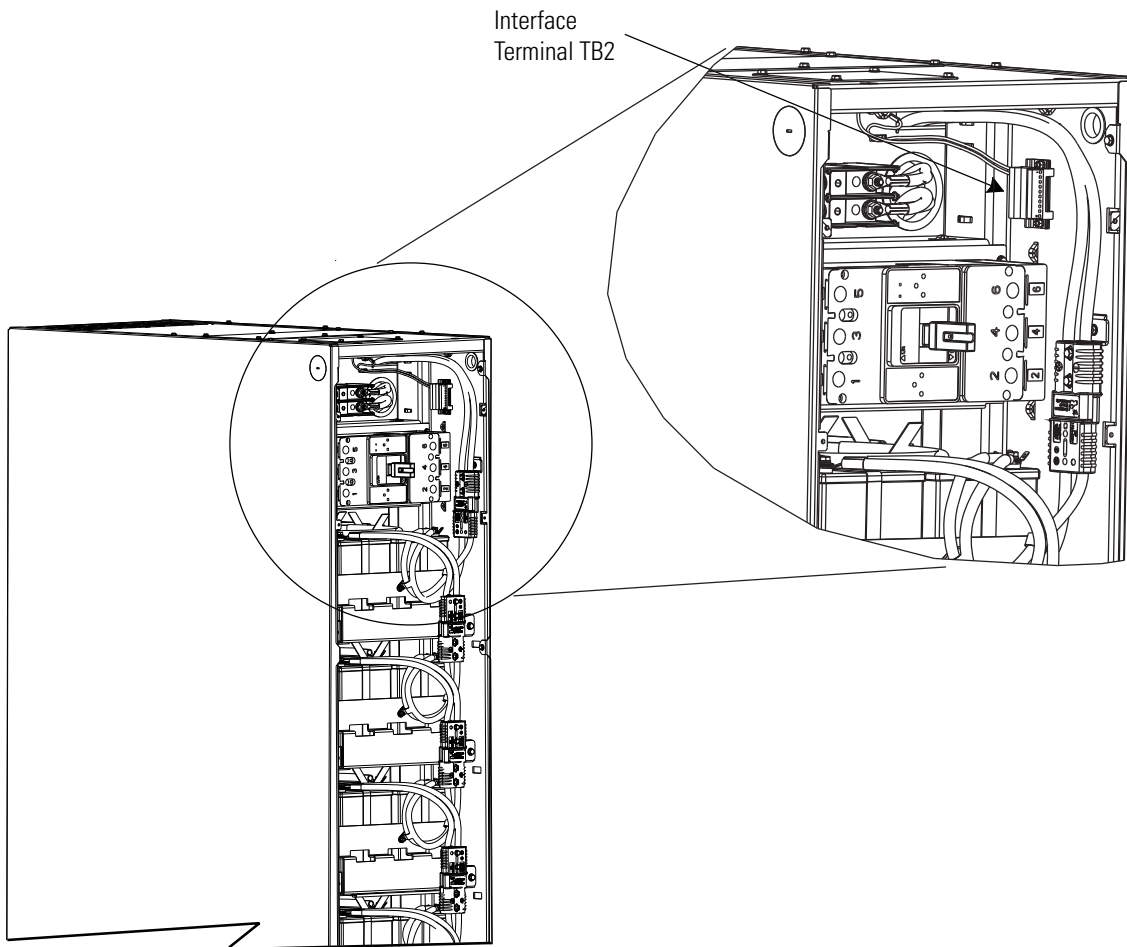

Table 7. IBC TB2 Interface Connections

Terminal TB2	Name	Description
10	Thermal Sensor	Contact used to signal a battery temperature out of specification and to turn off the battery charger to prevent thermal runaway.

Table 7. IBC TB2 Interface Connections (Continued)

Terminal TB2	Name	Description
9	Thermal Sensor Return	
8	Not Used	
7	To Next IBC TB2-2	Contacts used to open battery breaker or disconnect on second, third, and fourth IBCs.
6	To Next IBC TB2-1	
5	Battery Detect Common	Contacts used to indicate whether UPS battery breaker is open or closed.
4	Battery Detect	
3	Not Used	
2	48 Vdc Battery Shunt Trip –	Contacts used to open battery breaker or disconnect.
1	48 Vdc Battery Shunt Trip +	

Table 8. IBC TB2 Interface Wiring Terminal Block Terminations

Terminal Function	Size of Pressure Termination	Tightening Torque Nm (lb in)	Type Screw	Comments
Shunt Trip	#26–#16	0.4 (3.5) - 0.8 (7.1)	Slotted	Use #18 AWG twisted-pair wires for each input and return or common. Strip wire insulation back 10 millimeters to wire terminal blocks. Use wire rated for 600V and Class 1 wiring methods.
Battery Detect	#26–#16	0.4 (3.5) - 0.8 (7.1)	Slotted	Use #18 AWG twisted-pair wires for each input and return or common. Strip wire insulation back 10 millimeters to wire terminal blocks.
Thermal Sensor	#26–#16	0.4 (3.5) - 0.8 (7.1)	Slotted	Use #18 AWG twisted-pair wires for each input and return or common. Strip wire insulation back 10 millimeters to wire terminal blocks.

Figure 18. Shunt Trip, Battery Detect, and Thermal Sensor Wiring

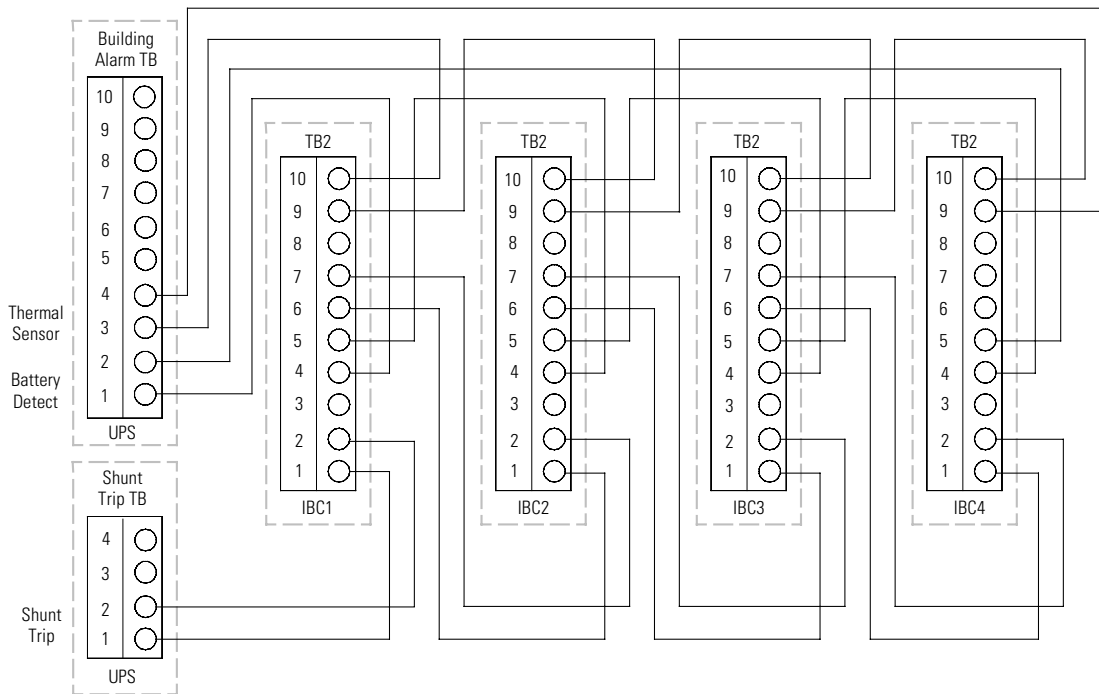

-
- NOTE 1** IBC–SW1 is closest to the UPS.
 - NOTE 2** The IBC–SW shunt trip is wired in parallel. The IBC–SW battery detect is wired in series.
 - NOTE 3** If less than four IBC–SWs are installed, the last IBC–SW TB2-5 connection returns to UPS Battery Detect Building Alarm terminal.
 - i** **NOTE 4** Because of the battery shunt trip wiring route in the 93PM UPS cabinet, the wiring from the IBC–SW battery shunt trip terminals to the UPS must use wire rated for 600V and Class 1 wiring methods.
 - NOTE 5** The Thermal Sensor is optional. If not installed, terminals TB2-9, and TB2-10 are not used.
-

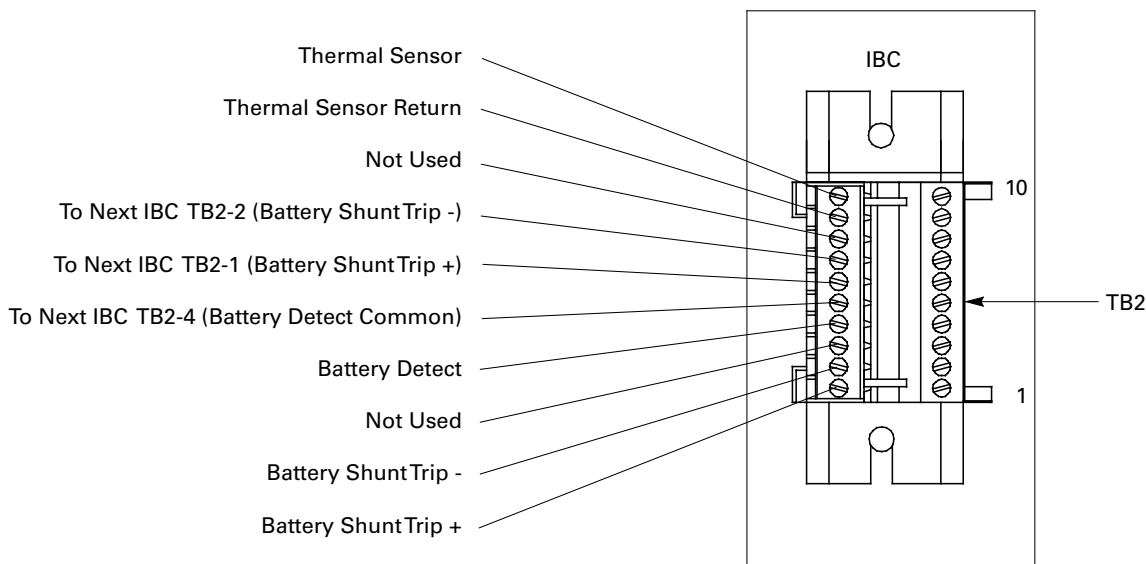
Figure 19. Interface Terminal Detail – Eaton 93PM IBC–SW

NOTE 1 TB2 connector pin 1 is located at the bottom of the terminal block.



NOTE 2 Because of the battery shunt trip wiring route in the 93PM UPS cabinet, the wiring from the IBC–SW battery shunt trip terminals to the UPS must use wire rated for 600V and Class 1 wiring methods.

NOTE 3 The Thermal Sensor is optional. If not installed, terminals TB2-9, and TB2-10 are not used.

4.4.2 Installing Battery Shunt Trip Interface Connections

NOTE 1 Disconnect terminal block plug from terminal block to wire plug.



NOTE 2 Because of the battery shunt trip wiring route in the 93PM UPS cabinet, the wiring from the IBC–SW shunt trip terminals to the UPS must use wire rated for 600V and Class 1 wiring methods.

NOTE 3 If the inter-cabinet wiring access pass-through is not used to install the battery shunt trip interface wiring connections, conduit must be installed between the battery cabinet and the UPS cabinet.

To install wiring:

1. If wiring the IBC–SW shunt trip interface terminals using the line-up-and-match inter-cabinet wiring access pass-through (see [Figure 9](#)) continue to **Step 2**; if wiring the IBC–SW shunt trip interface terminals using the top entry access, proceed to **Step 5**; if wiring the IBC–SW shunt trip interface terminals using the bottom entry access, proceed to **Step 8**.



NOTE In multiple IBC–SW installations, route the battery interface wiring between IBC–SWs through the top of the adjacent IBC–SW using the top side inter-cabinet access pass-through (see [Figure 9](#)).

2. **Line-Up-and-Match Wiring.** Route the battery shunt trip interface wiring from the UPS battery shunt trip interface terminals through the bottom inter-cabinet access pass-through (see [Figure 9](#)) of the UPS cabinet and IBC–SW to the wiring channel on the left side of the IBC–SW (see [Figure 12](#)). Route the wiring along the wiring channel to the IBC–SW battery interface terminal block TB2. See [Figure 17](#) for terminal locations. See paragraph [3.2.3 IBC–SW Interface Wiring Preparation, Table 7](#), and [Figure 18](#) for wiring and termination requirements. Refer to the applicable Eaton 93PM UPS Installation and Operation manual listed in paragraph [1.7 For More Information](#), for UPS cabinet terminal locations.
3. Secure the interface wiring to the wire tie anchors (see [Figure 14](#)) using Zip ties.
4. Proceed to **Step 11**.
5. **Top Entry Wiring.** Remove the top conduit plate (see [Figure 16](#)) from the top of the IBC–SW. Identify all conduit requirements and mark their location. Drill and punch all conduit holes in the top conduit plate prior to mounting on the IBC–SW. Install the conduit plate and install all conduit runs into the plate. Pull the wiring through the conduit into the wiring area.

NOTE In multiple IBC–SW installations, route the battery interface wiring between IBC–SWs through the top of the adjacent IBC–SW using the top side inter-cabinet access pass-through (see [Figure 9](#)).

6. Route the battery shunt trip interface wiring from the UPS battery shunt trip interface terminals through top of the IBC–SW to the IBC–SW battery interface terminal block TB2. See [Figure 17](#) for terminal locations. See paragraph [3.2.3 IBC–SW Interface Wiring Preparation, Table 7](#), and [Figure 18](#) for wiring and termination requirements. Refer to the applicable Eaton 93PM UPS Installation and Operation manual listed in paragraph [1.7 For More Information](#), for UPS cabinet terminal locations.
7. Proceed to **Step 11**.
8. **Bottom Entry Wiring.** Remove the bottom conduit plate (see [Figure 16](#)) from the inside bottom of the IBC–SW. Identify all conduit requirements and mark their location. Drill and punch all conduit holes in the bottom conduit plate prior to mounting on the IBC–SW. Install the conduit plate and install all conduit runs into the plate. Pull the wiring through the conduit into the wiring areas.

NOTE In multiple IBC–SW installations, route the battery interface wiring between IBC–SWs through the top of the adjacent IBC–SW using the top side inter-cabinet access pass-through (see [Figure 9](#)).

9. Route the battery shunt trip interface wiring from the UPS battery shunt trip interface terminals through the bottom of the IBC–SW to the wiring channel on the left side of the IBC–SW (see [Figure 12](#)). Route the wiring along the wiring channel to the IBC–SW battery interface terminal block TB2. See [Figure 17](#) for terminal locations. See paragraph [3.2.3 IBC–SW Interface Wiring Preparation, Table 7](#), and [Figure 18](#) for wiring and termination requirements. Refer to the applicable Eaton 93PM UPS Installation and Operation manual listed in paragraph [1.7 For More Information](#), for UPS cabinet terminal locations.
10. Secure the interface wiring to the wire tie anchors (see [Figure 14](#)) using Zip ties.
11. Connect the battery shunt trip interface wiring to the IBC–SW battery shunt trip interface terminals. See paragraph [3.2.3 IBC–SW Interface Wiring Preparation](#) and [Table 8](#) for termination requirements.
For a detailed view of the IBC–SW terminal block, see [Figure 19](#).
12. Connect the battery shunt trip interface wiring to the UPS battery shunt trip interface terminals. Refer to the applicable Eaton 93PM UPS Installation and Operation manual listed in paragraph [1.7 For More Information](#), for UPS cabinet termination requirements.

NOTE In the following step, if the safety shield cannot be reinstalled because of misalignment, use the leveling feet to realign the cabinet.

13. Reinstall the internal safety shield panel removed in **Step 3** of paragraph [4.3.1 Line-Up-and-Match Power Wiring](#).
14. Install the front cover (previously removed) by carefully lowering the cover onto the bottom mounting bolts. Secure the top of the cover with the two retained mounting bolts and tighten the bottom bolts.
15. Once the battery cabinets are installed and wired, return to the applicable Eaton 93PM UPS Installation and Operation manual, listed in paragraph [1.7 For More Information](#), to complete the UPS wiring.

4.4.3 Installing Thermal Sensor Interface Connections

NOTE 1 The UPS thermal sensor signal uses an UPS building alarm input to indicate a thermal trip condition and to turn off the battery charger.

NOTE 2 Any pair of unused building alarm terminals may be used for the thermal sensor connections.

 **NOTE 3** Program the thermal sensor building alarm to read battery thermal trip and for normally open contacts.

NOTE 4 Disconnect terminal block plug from terminal block to wire plug.

NOTE 5 If the inter-cabinet wiring access pass-through is not used to install the thermal sensor interface wiring connections, conduit must be installed between the battery cabinet and the UPS cabinet.

To install wiring:

1. If wiring the IBC–SW thermal sensor interface terminals using line-up-and-match wiring using the inter-cabinet wiring access pass-through (see [Figure 9](#)) continue to **Step 2**; if wiring the IBC–SW thermal sensor interface terminals using the top entry access, proceed to **Step 4**; if wiring the IBC–SW thermal sensor interface terminals using the bottom entry access, proceed to **Step 7**.

 **NOTE** In multiple IBC–SW installations, route the battery interface wiring between IBC–SWs through the top of the adjacent IBC–SW using the top side inter-cabinet access pass-through (see [Figure 9](#)).

2. **Line-Up-and-Match Wiring.** Route the thermal sensor interface wiring from the UPS thermal sensor (building alarm) interface terminals through the top inter-cabinet access pass-through (see [Figure 9](#)) of the UPS cabinet and IBC–SW to the IBC–SW battery interface terminal block TB2. See [Figure 17](#) for terminal locations. See paragraph [3.2.3 IBC–SW Interface Wiring Preparation, Table 7](#), and [Figure 18](#) for wiring and termination requirements. Refer to the applicable Eaton 93PM UPS Installation and Operation manual listed in paragraph [1.7 For More Information](#), for UPS cabinet terminal locations.
3. Proceed to **Step 10**.
4. **Top Entry Wiring.** Remove the top conduit plate (see [Figure 16](#)) from the top of the IBC–SW. Identify all conduit requirements and mark their location. Drill and punch all conduit holes in the top conduit plate prior to mounting on the IBC–SW. Install the conduit plate and install all conduit runs into the plate. Pull the wiring through the conduit into the wiring area.

 **NOTE** In multiple IBC–SW installations, route the battery interface wiring between IBC–SWs through the top of the adjacent IBC–SW using the top side inter-cabinet access pass-through (see [Figure 9](#)).

5. Route the thermal sensor interface wiring from the UPS thermal sensor (building alarm) interface terminals through the top of the IBC–SW and the top IBC–SW inter-cabinet wiring access pass-through (see [Figure 9](#)) to the IBC–SW battery interface terminal block TB2. See [Figure 17](#) for terminal locations. See paragraph [3.2.3 IBC–SW Interface Wiring Preparation, Table 7](#), and [Figure 18](#) for wiring and termination

requirements. Refer to the applicable Eaton 93PM UPS Installation and Operation manual listed in paragraph [1.7 For More Information](#), for UPS cabinet terminal locations.

6. Proceed to **Step 10**.
7. **Bottom Entry Wiring.** Remove the bottom conduit plate (see [Figure 16](#)) from the inside bottom of the IBC–SW. Identify all conduit requirements and mark their location. Drill and punch all conduit holes in the bottom conduit plate prior to mounting on the IBC–SW. Install the conduit plate and install all conduit runs into the plate. Pull the wiring through the conduit into the wiring areas.

i **NOTE** In multiple IBC–SW installations, route the battery interface wiring between IBC–SWs through the top of the adjacent IBC–SW using the top side inter-cabinet access pass-through (see [Figure 9](#)).

8. Route the thermal sensor interface wiring from the UPS thermal sensor (building alarm) interface terminals through the bottom of the IBC–SW to the wiring channel on the left side of the IBC–SW (see [Figure 12](#)). Route the wiring along the wiring channel to the IBC–SW battery interface terminal block TB2. See [Figure 17](#) for terminal locations. See paragraph [3.2.3 IBC–SW Interface Wiring Preparation, Table 7](#), and [Figure 18](#) for wiring and termination requirements. Refer to the applicable Eaton 93PM UPS Installation and Operation manual listed in paragraph [1.7 For More Information](#), for UPS cabinet terminal locations.
9. Secure the interface wiring to the wire tie anchors (see [Figure 14](#)) using Zip ties.
10. Connect the thermal sensor interface wiring to the IBC–SW thermal sensor interface terminals. See paragraph [3.2.3 IBC–SW Interface Wiring Preparation](#) and [Table 8](#) for termination requirements.

For a detailed view of the IBC–SW terminal block, see [Figure 19](#).
11. Connect the thermal sensor interface wiring to the UPS thermal sensor interface (building alarm) terminals. Refer to the applicable Eaton 93PM UPS Installation and Operation manual listed in paragraph [1.7 For More Information](#), for UPS cabinet termination requirements.

i **NOTE** In the following step, if the safety shield cannot be reinstalled because of misalignment, use the leveling feet to realign the cabinet.

12. Reinstall the internal safety shield panel removed in **Step 3** of paragraph [4.3.1 Line-Up-and-Match Power Wiring](#).
13. Install the front cover (previously removed) by carefully lowering the cover onto the bottom mounting bolts. Secure the top of the cover with the two retained mounting bolts and tighten the bottom bolts.
14. Once the battery cabinets are installed and wired, return to the applicable Eaton 93PM UPS Installation and Operation manual, listed in paragraph [1.7 For More Information](#), to complete the UPS wiring.

4.5 Initial Startup

Startup and operational checks must be performed by an authorized Eaton Customer Service Engineer, or the warranty terms specified in [Chapter 8 Warranty](#) become void. This service is offered as part of the sales contract for the UPS. Contact an Eaton service representative in advance (a minimum two-week notice is required) to reserve a preferred startup date.

4.6 Completing the Installation Checklist

The final step in installing the IBC–SW is completing the following Installation Checklist. This checklist ensures that you have completely installed all hardware, cables, and other equipment. Complete all items listed on the checklist to ensure a smooth installation. Make a copy of the Installation Checklist before filling it out, and retain the original.

After the installation is complete, an Eaton Customer Service Engineer must verify the operation of the UPS system and commission it to support the critical load. The service representative cannot perform any

installation tasks other than verifying software and operating setup parameters. Service personnel may request a copy of the completed Installation Checklist to verify all applicable equipment installations have been completed.

**NOTE**

The Installation Checklist MUST be completed prior to starting the UPS system for the first time.

Installation Checklist

- All IBCs are the same model and rating.
- All packing materials and restraints have been removed from each cabinet.
- The IBCs are installed on a level floor suitable for computer or electronic equipment.
- The IBCs are placed in their installed location
- All conduits and cables are properly routed between the IBCs and the UPS.
- All power cables are properly sized and terminated.
- A ground conductor is properly installed.
- Battery cables are terminated on the positive and negative terminals in the UPS cabinet.
- Battery Shunt trip and Battery Detect signal wiring is connected from the battery breaker to the UPS.
- All internal safety shields are installed.
- Air conditioning equipment is installed and operating correctly.
- The area around the UPS system is clean and dust-free.
- Adequate workspace exists around the IBC and other cabinets.
- Adequate lighting is provided around all IBC and UPS equipment.
- A 120 Vac service outlet is located within 7.5 meters (25 feet) of the IBC and UPS equipment.
- Startup and operational checks are performed by an authorized Eaton Customer Service Engineer.
- Visit www.eaton.com/pg/register to register your new Eaton UPS / Eaton UPS Accessory.

Chapter 5 Onelines and Schematics

5.1 Power Onelines

Figure 20 through Figure 22 show the 93PM UPS and 93PM Integrated Battery Cabinet inter-cabinet power connection onelines.

Figure 20. 93PM Integrated Battery Cabinet Line-Up-and-Match Power Oneline

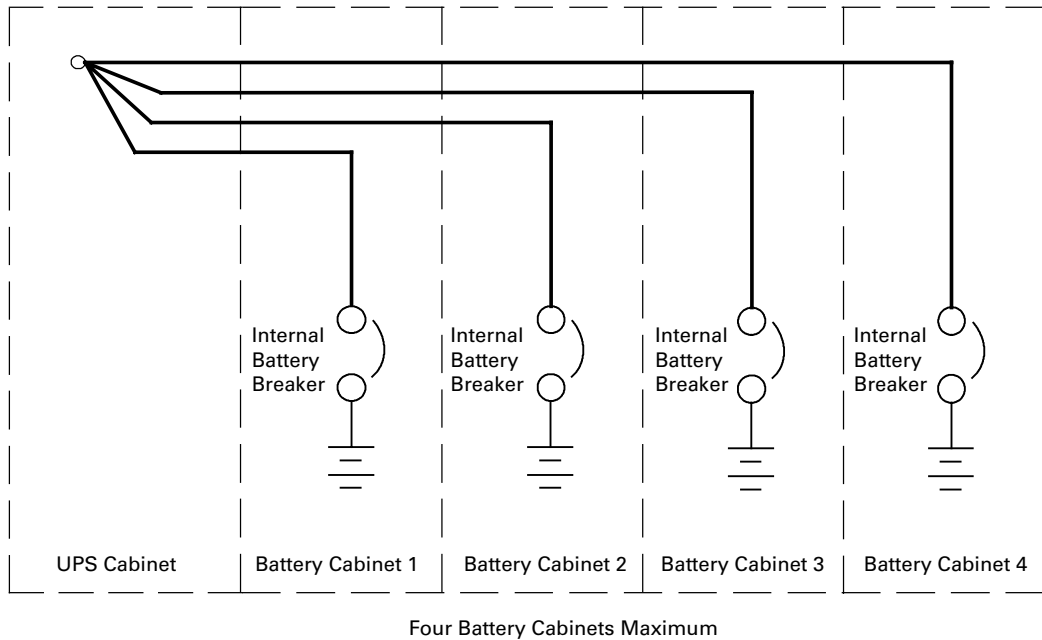

NOTE

Three and four battery cabinet wiring assumes using factory supplied wiring and one wire per pole.

Figure 21. 93PM Integrated Battery Cabinet Standalone Power Online – One or Two Cabinets

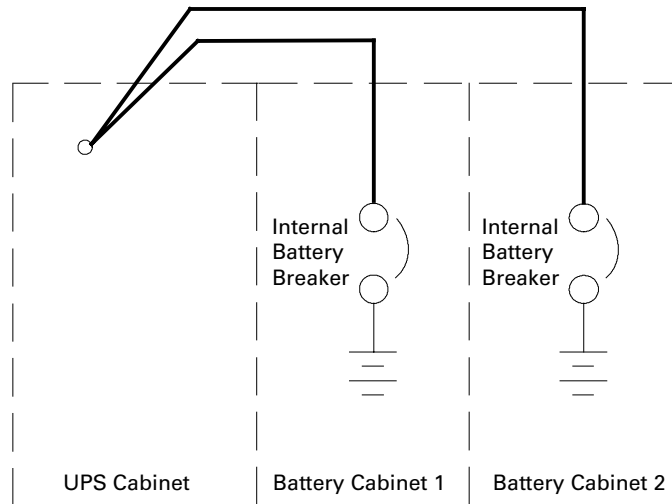

i NOTE External wiring to be supplied by the customer.

Figure 22. 93PM Integrated Battery Cabinet Standalone Power Online – Three or Four Cabinets

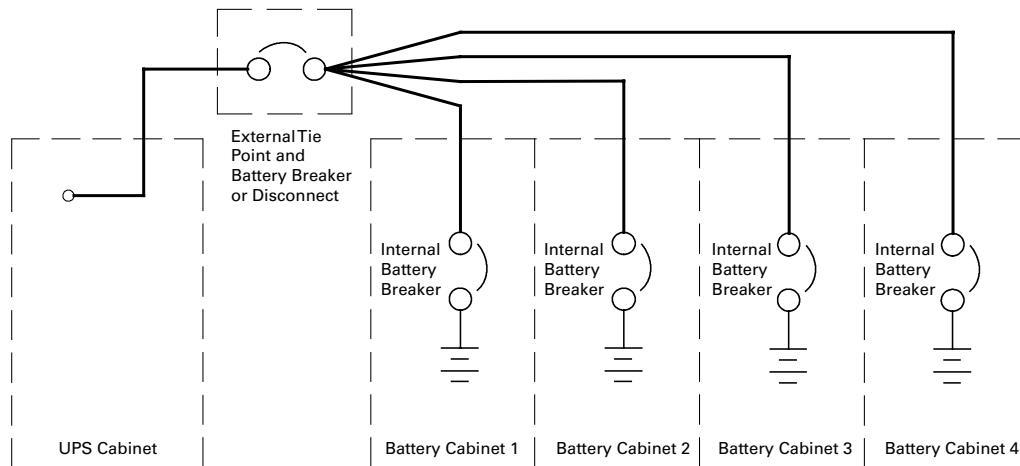

i NOTE External tie point, battery breaker or disconnect, and wiring to be supplied by the customer.

5.2 Interface Onelines

[Figure 23](#) shows the 93PM UPS and 93PM Integrated Battery Cabinet inter-cabinet interface connection onelines.

Figure 23. 93PM Integrated Battery Cabinet Interface Oneline

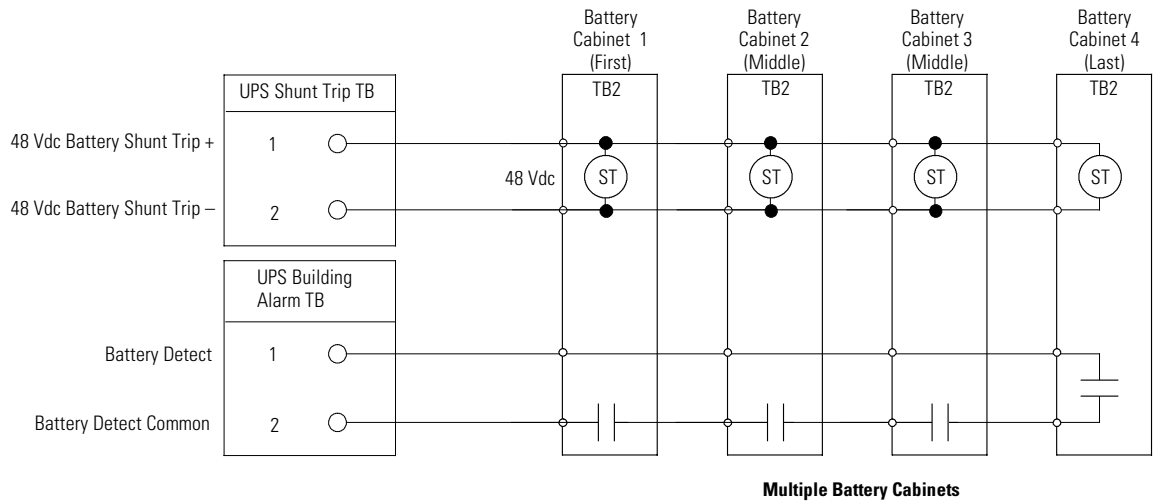
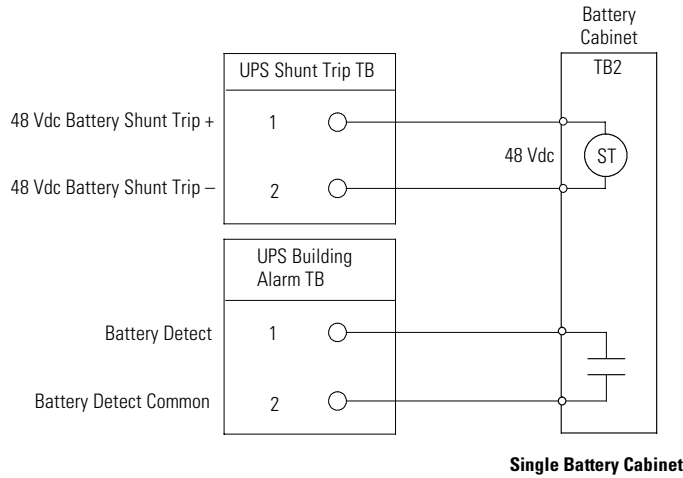

NOTE Battery Detect and DC Shunt Trip wiring should be a minimum of 18 AWG.

5.3 Schematics

[Figure 24](#) and [Figure 25](#) show the 93PM Integrated Battery Cabinet schematics.

Figure 24. 93PM Integrated Battery Cabinet Schematic

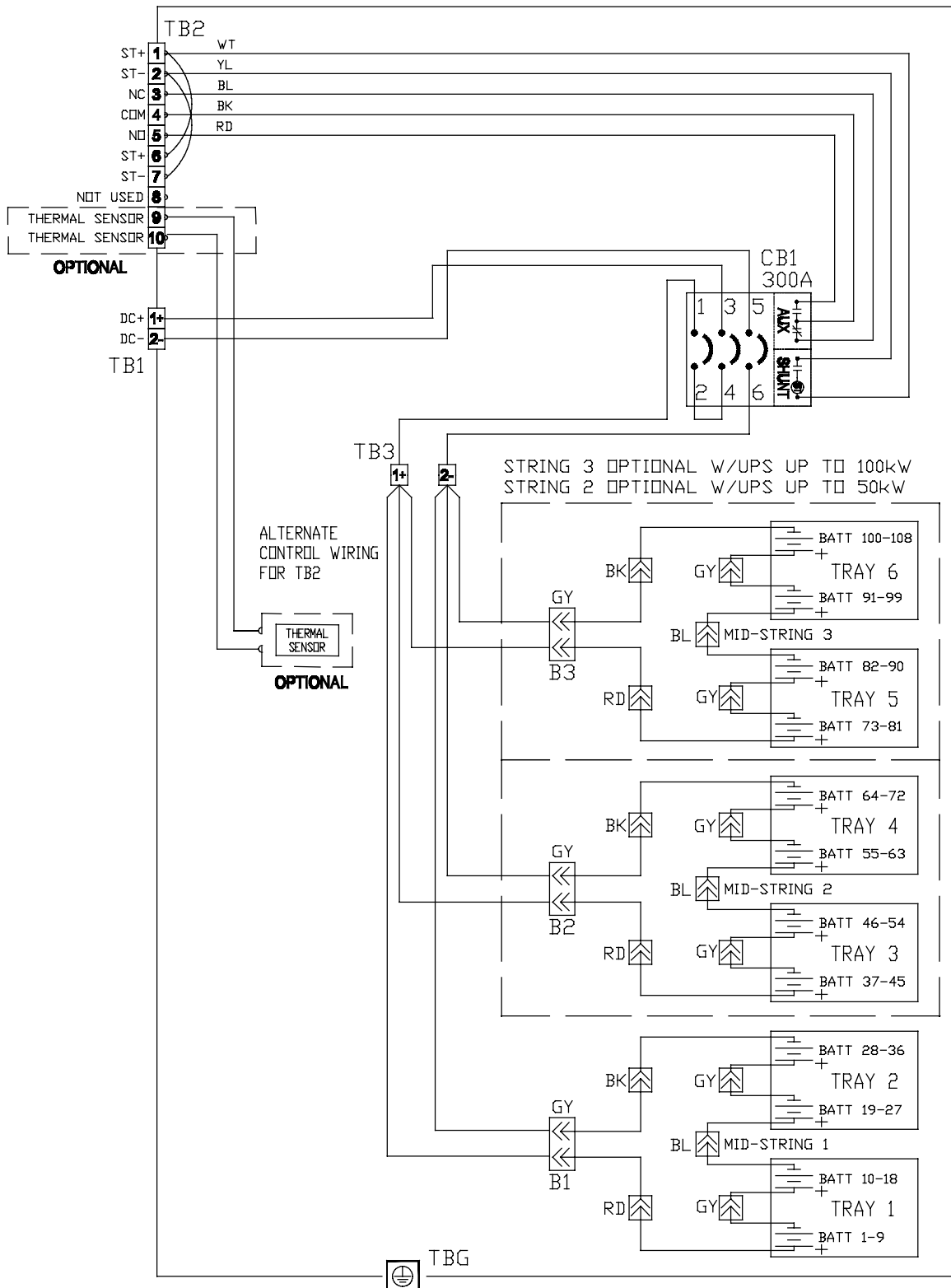
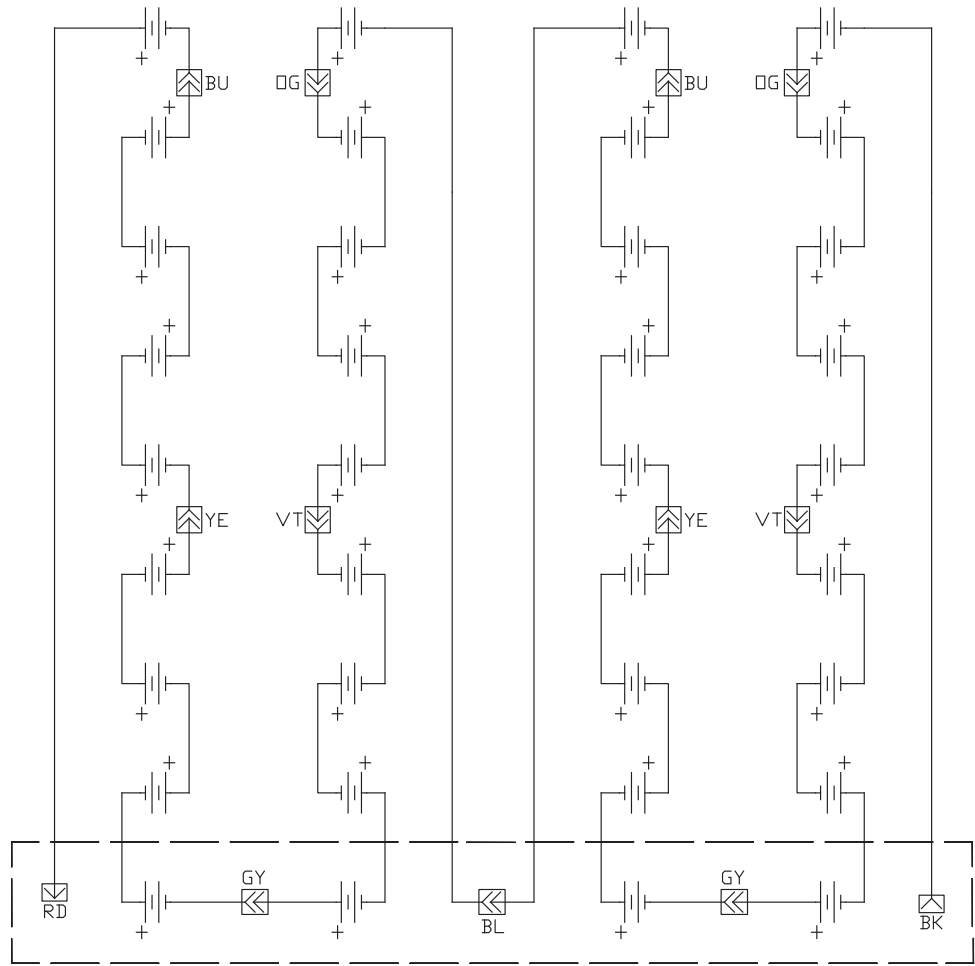

Figure 25. 93PM Integrated Battery Cabinet – Battery String Detail Schematic



Chapter 6 Maintenance

The components inside the IBC are secured to a sturdy metal frame. All repairable parts and assemblies are located for easy removal, with very little disassembly. This design allows authorized service personnel to perform routine maintenance and servicing quickly.

You must schedule periodic performance checks of the UPS system to keep it running properly. Regular routine checks of operation and system parameters enable your system to function efficiently for many trouble-free years.

6.1 Important Safety Instructions

Remember that your UPS system is designed to supply power **EVEN WHEN DISCONNECTED FROM THE UTILITY POWER.**



WARNING

- No user serviceable components.
 - Servicing and maintenance should be performed by qualified service personnel only.
 - **LETHAL VOLTAGE PRESENT.** This unit should not be operated with the cabinet doors open or protective panels removed. Do not make any assumptions about the electrical state of any cabinet in the UPS system.
-

6.2 Performing Preventive Maintenance

The UPS system requires very little preventive maintenance. However, the system should be inspected periodically to verify that the units are operating normally. Record maintenance results and any corrective actions in a suitable log.

6.2.1 DAILY Maintenance

Perform the following steps daily:

1. Check the area surrounding the UPS system. Ensure the area is not cluttered, allowing free access to the unit.
2. Ensure the air intakes on the Accessory cabinets are not blocked.
3. Ensure the operating environment is within the parameters specified in paragraph **3.2.1 Environmental and Installation Considerations** and **Chapter 7 Product Specifications**.

6.2.2 PERIODIC Maintenance

Periodic inspections of the IBC should be made to determine if components, wiring, and connections exhibit evidence of overheating. Particular attention should be given to the compression lug connections. Maintenance procedures should specify that the compression lug connections be retorqued to values listed in this manual.

6.2.3 ANNUAL Maintenance

Annual preventive maintenance should be performed only by authorized service personnel familiar with maintenance and servicing of the UPS system. Contact an Eaton service representative for more information about service offerings.

6.2.4 BATTERY Maintenance

Contact an Eaton service representative for battery maintenance. Battery replacement and maintenance should be performed only by authorized service personnel.

6.2.5 BATTERY Shelf Life

The shelf life for the batteries installed in the IBC is 12 months from the date code on the battery. The recharge date is also stated on a label inside the IBC.

 **CAUTION**

Failure to recharge the batteries before the expiration of the shelf life will result in reduced discharge time, shorter float service life, and will void the warranty.

6.3 Recycling the Used Batteries

Contact your local recycling or hazardous waste center for information on proper disposal of the used Valve-Regulated Lead-Acid (VRLA) batteries.

 **WARNING**

- Do not dispose of the battery or batteries in a fire. Batteries may explode. Proper disposal of batteries is required. Refer to your local codes for disposal requirements.
 - Do not open or mutilate the battery or batteries. Released electrolyte is harmful to the skin and eyes. It may be toxic.
 - A battery can cause electrical shock, burn from high short-circuit current, or fire. Observe proper precautions.
-

 **ATTENTION!**

- Une batterie peut présenter un risque de choc électrique, de brûlure, ou d'incendie. Suivre les précautions qui s'imposent.
 - Pour le remplacement, utiliser le même nombre et modèle des batteries.
 - L'élimination des batteries est réglementée. Consulter les codes locaux à cet effet.
-

 **CAUTION**

Do not discard the UPS or the UPS batteries in the trash. This product contains sealed, lead-acid batteries and must be disposed of properly. For more information, contact your local recycling/reuse or hazardous waste center.

 **CAUTION**

Do not discard waste electrical or electronic equipment (WEEE) in the trash. For proper disposal, contact your local recycling/reuse or hazardous waste center.

6.4 Maintenance Training

A basic training course, available from Eaton, gives you a competent working knowledge of the UPS system operation and teaches you how to perform first level corrective maintenance. For more information about training and other services, contact the Customer Reliability Center (see paragraph **1.8 Getting Help**).

Chapter 7 Product Specifications

This section provides the following specifications:

- Model Numbers
- Battery specifications
- Environmental and safety specifications

7.1 Models

The Integrated Battery Cabinet – Small Welded (IBC–SW) is available in two models to meet the needs of the Eaton 93PM UPS product line.

Integrated Battery Cabinet (IBC)	DC Voltage Output (Nominal)	Battery Nameplate Current	Description
Eaton 93PM Integrated Battery Cabinet-Small Welded	432V	165A	IBC for: Eaton 93PM (400/480V) 50 kW UPS Eaton 93PM (400/480V) 100 kW UPS Eaton 93PM (400/480V) 150 kW UPS Eaton 93PM (400/480V) 200 kW UPS
	480V	158A	IBC for: Eaton 93PM-L (208V) 60 kW UPS Eaton 93PM-L (208V) 120 kW UPS Eaton 93PM-L (208V) 160 kW UPS Eaton 93PM-L (208V) 200 kW UPS and Eaton 93PM (400/480V) 50 kW UPS Eaton 93PM (400/480V) 100 kW UPS Eaton 93PM (400/480V) 150 kW UPS Eaton 93PM (400/480V) 200 kW UPS

7.2 Specifications

The following sections detail the battery specifications, battery runtimes, and the environmental and safety specifications for the UPS. Specifications are subject to change.

7.2.1 Battery Specifications

IBC-SW Battery Type	Eaton PWHR12200W4FR or CSB HRL12200WFR 200 Watts/cell valve-regulated lead-acid (VRLA) with a 3-5 year float service life at 77°F (25°C)
Number of Strings	IBC–SW (432V) 1 string with 36 Batteries IBC–SW (480V) 1 string with 40 Batteries
Battery Replacement	Must be replaced by a qualified service technician
Protection	IBC–SW output protected by 250A circuit breaker.



The shelf life for the batteries installed in the IBC is 6 months from the date code on the battery. The recharge date is also stated on a label inside the IBC.

Failure to recharge the batteries before the expiration of the shelf life will result in reduced discharge time, shorter float service life, and will void the warranty.

7.2.2 Environmental and Safety Specifications

Operating Temperature	The battery cabinet is rated for operation in up to a 40°C (104°F) ambient temperature. The batteries are rated for a 25°C (77°F) ambient temperature to extend their useful life.
Transit Temperature	-25°C to 60°C (-13°F to 140°F) Recommended Eaton PWHR12200W4FR or CSB HRL12200WFR Battery Transit: -20°C to 50°C (-4°F to 122°F)
Storage Temperature	-25°C to 55°C (-13°F to 131°F) Recommended Eaton PWHR12200W4FR or CSB HRL12200WFR Battery Storage: -20°C to 30°C (-4°F to 86°F)
Operating Altitude	Maximum 1500m (5000 ft) at 40°C without derating
Transit Altitude	15000m (49213 ft)
Ventilation	Convection
Relative Humidity (operating and storage)	5 to 95%, noncondensing
Acoustical Noise	Not applicable
Safety Conformance	UL1778 5 th edition
Agency Markings	cULus
EMC (Class A)	FCC Part 15 Class A and 62040-2 C3

Chapter 8 Warranty

8.1 Limited Factory Warranty for Three-Phase Eaton 93PM UPS and 93PM UPS Accessory Products

WARRANTOR: The warrantor for the limited warranties set forth herein is Eaton ("Eaton").

LIMITED WARRANTY: This limited warranty (this "Warranty") applies only to the original end-user (the "End-User") of the Eaton Three-Phase 93PM UPS and 93PM UPS Accessory Products (the "Product") and cannot be transferred. This restriction applies even in the event that the Product is initially sold by Eaton for resale to an End-User. This Warranty gives you specific legal rights, and you may also have other rights which vary from State to State (or jurisdiction to jurisdiction).

WHAT THIS LIMITED WARRANTY COVERS: The warrantor warrants, with the terms of this Warranty, that the Eaton three-phase UPS electronics, Eaton-built accessories, and Eaton-built battery cabinets (individually and collectively, the "Warranted Items") are free from defects in material and workmanship.

For Product installed (and currently located) in the fifty (50) United States and the District of Columbia, if, in the opinion of Eaton, a Warranted Item is defective, Eaton's sole obligation, at the option of Eaton, will be to refurbish or replace such defective Warranted Item (including the costs of providing diagnosis, service, and labor ["labor coverage"]). The defective Warranted Item will be refurbished or replaced onsite at the End-User's location or such other location as determined by Eaton. Any parts that are replaced may be new or reconditioned. All parts replaced by Eaton shall become the property of Eaton.

For Product installed (and currently located) outside the fifty (50) United States and the District of Columbia, if, in the opinion of Eaton, a Warranted Item is defective, Eaton's sole obligation, at the option of Eaton, will be to refurbish or replace such defective Warranted Item (not including the costs of labor coverage). The defective Warranted Item will be refurbished or replaced onsite at the End-User's location or such other location as determined by Eaton. Any parts that are replaced may be new or reconditioned. All parts replaced by Eaton shall become the property of Eaton.

LIMITED WARRANTY PERIOD: The period covered by this Warranty for Product installed (and currently located) in the fifty (50) United States and the District of Columbia is six (6) months from the date of Product purchase for labor coverage when no startup is performed by an authorized Eaton Customer Service Engineer or Agent or twelve (12) months from the date of Product purchase with startup performed by an authorized Eaton Customer Service Engineer or Agent and twelve (12) months from the date of Product purchase or eighteen (18) months from date of Product shipment, whichever occurs first, for the refurbishment/replacement of parts.

The period covered by this Warranty for Product installed (and currently located) outside the fifty (50) United States and the District of Columbia is twelve (12) months from the date of Product purchase or eighteen (18) months from the date of Product shipment, whichever occurs first, for the refurbishment/replacement of parts.

WHAT THIS LIMITED WARRANTY DOES NOT COVER: This Warranty does not cover any defects or damages caused by: (a) failure to properly store the Product before installation, including the "trickle charge" of batteries no later than the date indicated on the packaging; (b) shipping and delivery of the Product if shipping is FOB Factory; (c) neglect, accident, fire, flood, lightning, vandalism, acts of God, Customer's neglect, abuse, misuse, misapplication, incorrect installation; (d) repair or alteration not authorized in writing by Eaton personnel or performed by an authorized Eaton Customer Service Engineer or Agent; or (e) improper testing, operation, maintenance, adjustment, or any modification of any kind not authorized in writing by Eaton personnel or performed by an authorized Eaton Customer Service Engineer or Agent.

This Warranty is not valid: if the Product's serial numbers have been removed or are illegible. Any Warranted Items repaired or replaced pursuant to this Warranty will be warranted for the remaining portion of the original Warranty subject to all the terms thereof. Eaton does not provide a labor warranty for Product located outside of the fifty (50) United States or the District of Columbia. **Any equipment, parts, or materials included in the Product and not manufactured by Eaton are warranted solely by the manufacturer of such equipment, parts, or materials and are not included as part of this Warranty. Batteries are not warranted by Eaton.**

THIS WARRANTY IS THE ENDUSER'S SOLE REMEDY AND IS EXPRESSLY IN LIEU OF, AND THERE ARE NO OTHER, EXPRESSED OR IMPLIED GUARANTEES OR WARRANTIES (INCLUDING ANY IMPLIED WARRANTY OF MERCHANTABILITY OR FITNESS FOR ANY PURPOSE, WHICH ARE EXPRESSLY DISCLAIMED). SOME STATES OR JURISDICTIONS DO NOT ALLOW THE EXCLUSION OF EXPRESS OR IMPLIED WARRANTIES, SO THE ABOVE EXCLUSION MAY NOT APPLY TO YOU. IN THAT EVENT, SUCH WARRANTIES ARE LIMITED IN DURATION TO THE LIMITED WARRANTY PERIOD. SOME STATES OR JURISDICTIONS DO NOT ALLOW LIMITATIONS ON HOW LONG AN IMPLIED WARRANTY LASTS OR THE EXCLUSION OR LIMITATION OF INCIDENTAL OR CONSEQUENTIAL DAMAGES, SO THE ABOVE LIMITATIONS AND/OR EXCLUSIONS MAY NOT APPLY TO YOU.

LIMITATION OF LIABILITY: In no event shall Eaton be liable for any indirect, incidental, special or consequential damages of any kind or type whatsoever, resulting from or in connection with any claim or cause of action, whether brought in contract or in tort (including negligence and strict liability). Some States or jurisdictions do not allow the exclusion of limitation of incidental or consequential damages, so the above limitation or exclusion may not apply to you. Eaton shall not be responsible for failure to provide service or parts due to causes beyond Eaton's reasonable control. In no case will Eaton's liability under this Warranty exceed the replacement value of the Warranted Items.

END-USER'S OBLIGATIONS: In order to receive the benefits of this Warranty, the End-User must register the product warranty (via mail or online at www.eaton.com/pg/register "product registration"); use the Product in a normal way; follow the Product's user's guide; and protect against further damage to the Product if there is a covered defect.

OTHER LIMITATIONS: Eaton's obligations under this Warranty are expressly conditioned upon receipt by Eaton of all payments due to it (including interest charges, if any). During such time as Eaton has not received payment of any amount due to it for the Product, in accordance with the contract terms under which the Product is sold, Eaton shall have no obligation under this Warranty. Also during such time, the period of this Warranty shall continue to run and the expiration of this Warranty shall not be extended upon payment of any overdue or unpaid amounts.

COSTS NOT RELATED TO WARRANTY: The End-User shall be invoiced for, and shall pay for, all services not expressly provided for by the terms of this Warranty, including without limitation site calls involving an inspection that determines no corrective maintenance is required. Any costs for replacement equipment, installation, materials, freight charges, travel expenses, or labor of Eaton representatives outside the terms of this Warranty will be borne by the End-User.

OBTAINING WARRANTY SERVICE: In the USA, call the Eaton Customer Reliability Center 7x24 at 800-843-9433. Outside of the USA, call your local Eaton sales or service representative, or call the Eaton Customer Reliability Center in the United States at 919845-3633. For comments or questions about this Limited Factory Warranty, write to the Customer Quality Representative, 8609 Six Forks Road, Raleigh, North Carolina 27615 USA.



164000639 03