

# Eaton® 93PM Universal Integrated Battery Cabinet

IBC-LW [Large] (432V and 480V)

IBC-LHW [Large High Rate] (432V and 480V)

Installation Manual



*Powering Business Worldwide*

p/n: P-164000541  
Revision 04

---

## **IMPORTANT SAFETY INSTRUCTIONS SAVE THESE INSTRUCTIONS**

---

This manual contains important instructions that should be followed during installation and maintenance of the UPS and batteries. Read all instructions before operating the equipment and save this manual for future reference.

---

---

## **CONSIGNES DE SÉCURITÉ IMPORTANTES – CONSERVER CES INSTRUCTIONS**

---

Ce manuel comporte des instructions importantes que vous êtes invité à suivre lors de toute procédure d'installation et de maintenance des batteries et de l'onduleur. Veuillez consulter entièrement ces instructions avant de faire fonctionner l'équipement et conserver ce manuel afin de pouvoir vous y reporter ultérieurement.

---



### **IMPORTANT**

---

To ensure you have the most up-to-date content and information for this product, please review the latest manual revision on our website, [www.eaton.com/93PM](http://www.eaton.com/93PM).

---

Eaton reserves the right to change specifications without prior notice. Modbus is a registered trademark of Schneider Automation, Inc. MOXA is a registered trademark and MGate is a trademark of MOXA, Inc. Spiralock is a registered trademark of Spiralock Corporation. KIRK is a registered trademark of Kirk Key Interlock company, LLC, a subsidiary of Halma plc. National Electrical Code and NEC are registered trademarks of National Fire Protection Association, Inc. ERIFLEX and FLEXIBAR are registered trademark of Erico International Corporation. All other trademarks are property of their respective companies.

©Copyright 2016-2019 Eaton, Raleigh, NC, USA. All rights reserved. No part of this document may be reproduced in any way without the express written approval of Eaton.

**EATON  
END-USER LICENSE AGREEMENT**

IMPORTANT, READ CAREFULLY. THIS END USER LICENSE AGREEMENT (THE "AGREEMENT") IS A BINDING CONTRACT BETWEEN YOU, THE END-USER (THE "LICENSEE") AND EATON INTELLIGENT POWER LIMITED, IRELAND, OR ONE OF ITS AFFILIATES ("EATON" OR "LICENSOR"), BY OPERATING THIS UNINTERRUPTIBLE POWER SUPPLY (UPS) PRODUCT INCLUDING SOFTWARE EMBEDDED IN IT (FIRMWARE), YOU, THE LICENSEE, ARE AGREEING TO BE BOUND BY THE TERMS, CONDITIONS, AND LIMITATIONS OF THIS AGREEMENT. READ THE TERMS AND CONDITIONS OF THIS AGREEMENT CAREFULLY BEFORE, INSTALLING OR OPERATING THE PRODUCT. IF YOU DO NOT AGREE TO THE TERMS OF THIS AGREEMENT, PROMPTLY RETURN THE UNUSED PRODUCT TO EATON.

**1.0 DEFINITIONS**

**1.1 Documentation.** "Documentation" means the user guides and manuals for the installation and use of the UPS, whether made available over the internet, provided in CD-ROM, DVD, hard copy or other form.

**1.2 Firmware.** "Firmware" means software programs that are embedded in the product for which Licensee is granted a license hereunder, the Documentation therefore and, to the extent available, Updates thereto. The Firmware is licensed hereunder in object code (machine-readable) form only except that certain software programs may include limited portions in source code (human-readable) form.

**1.3 Update.** "Update" means a subsequent release of the Firmware, if and when developed by Eaton. An Update does not include any release, new version, option, or future product, which Eaton licenses separately.

**2.0 FIRMWARE LICENSE**

**2.1 Ownership.** Eaton or its third party licensors retains all title, copyright and other proprietary rights in, and ownership of the Firmware regardless of the media upon which the original or any copy may be recorded or fixed.

**2.2 License Grant.** Eaton grants to Licensee a limited, revocable, non-exclusive, non-assignable license to use the Firmware in conjunction with the operation of the product to which the Firmware pertains or other products as described by Eaton in the Documentation. Licensee does not acquire any rights, express or implied, other than those expressly granted in this Agreement.

**2.3 Restrictions and Requirements.** Licensee will not, nor will it permit others to, modify, adapt, translate, reverse engineer, decompile, or disassemble the Firmware or any component thereof (including the Documentation), or create derivative works based on the Firmware (including the Documentation), except to the extent such foregoing restriction is prohibited by applicable law or applicable open source license to, and only to, any open source software component that is incorporated into the Firmware (if any). Copyright laws and international treaties protect the Firmware, including the Documentation. Unauthorized copying of the Firmware, the Documentation or any part thereof, is expressly prohibited. For avoidance of doubt, Eaton does not grant Licensee a license to any of Eaton's brands, logos, designs, trade dress, service marks, trademarks, domain names or trade names, in whole or in part. Licensee agrees to install or allow installation of all corrections of substantial defects, security patches, minor bug fixes and updates, including any enhancements, for the Firmware in accordance with the instructions and as directed by Eaton.

**2.4 Transfer and Assignment Restrictions.** Licensee will not sell, resell, assign, lease, sublicense, encumber, or otherwise transfer its interest in this Agreement or in the Firmware, or the Documentation in whole or in part, or allow any other person or entity, including any parent or subsidiary of Licensee or other subsidiary of Licensee's parent, to copy, distribute, or otherwise transfer the Firmware without the prior written consent of Eaton. Licensee may transfer the Firmware directly to a third party only in connection with the sale of the Eaton product in which it is installed.

**3.0 TERMINATION**

**3.1 Termination.** This Agreement and the license granted hereunder automatically terminates if Licensee breaches any provision of this Agreement. Eaton may terminate this license at any time with or without cause.

**3.2 Effect of Termination.** Immediately upon termination of this Agreement or the license granted hereunder, Licensee will cease using the product. The parties' rights and obligations under the following sections of this Agreement will survive termination of this Agreement: Article 1.0, Section 2.1, Section 2.3, Section 2.4, Article 3.0, Article 4.0 and Article 5.0.

**4.0 INFRINGEMENT AND WARRANTIES**

**4.1 Infringement.** If Licensee learns of a threat, demand, allegation, or indication that the UPS with its firmware infringes or misappropriates any third party intellectual property rights (including but not limited to any patent, copyright, trademark, trade dress, or trade secret) ("Intellectual Property Claim"), Licensee will notify Eaton promptly of such claim. Eaton may, in its sole discretion, elect to assume sole control of the defense and settlement of said Intellectual Property Claim and Licensee will provide reasonable information and assistance to Eaton for the defense of such claim.

**4.2 Disclaimer of Warranties.** THE FIRMWARE IS PROVIDED "AS IS" WITHOUT WARRANTY OF ANY KIND, EATON DOES NOT WARRANT THAT THE FIRMWARE WILL BE ERROR-FREE OR SECURE FROM UNAUTHORIZED ACCESS. THE LICENSEE EXPRESSLY ACKNOWLEDGES THAT TO THE EXTENT PERMITTED BY APPLICABLE LAW, THE USE OF THE PRODUCT IS AT LICENSEE'S SOLE RISK.

**5.0 GENERAL PROVISIONS**

**5.1 Update Policy.** Eaton may from time to time, but has no obligation to, create Updates of the Firmware or components thereof.

**5.2 Limitation on Liability.** NOTWITHSTANDING ANY PROVISION OF THIS AGREEMENT TO THE CONTRARY, LICENSEE EXPRESSLY UNDERSTANDS AND AGREES THAT EATON, ITS AFFILIATES, AND ITS LICENSORS, WILL NOT BE LIABLE FOR: (A) ANY DIRECT, INDIRECT, INCIDENTAL, SPECIAL, CONSEQUENTIAL OR EXEMPLARY DAMAGES WHICH MAY BE INCURRED BY LICENSEE OR ANY THIRD PARTY, HOWEVER CAUSED AND UNDER ANY THEORY OF LIABILITY THIS WILL INCLUDE, BUT NOT BE LIMITED TO, ANY LOSS OF PROFIT (WHETHER INCURRED DIRECTLY OR INDIRECTLY), ANY LOSS OF GOODWILL OR BUSINESS REPUTATION, ANY LOSS OF DATA SUFFERED, COST OF PROCUREMENT OF SUBSTITUTE GOODS OR SERVICES, OR OTHER INTANGIBLE LOSS; (B) ANY LOSS OR DAMAGE WHICH MAY BE INCURRED BY LICENSEE OR ANY THIRD PARTY. THESE LIMITATIONS ON EATON'S LIABILITY WILL APPLY WHETHER OR NOT EATON HAS BEEN ADVISED OF OR SHOULD HAVE BEEN AWARE OF THE POSSIBILITY OF ANY SUCH LOSSES ARISING.

TO THE EXTENT PERMITTED BY LAW, THE TOTAL LIABILITY OF EATON, ITS AFFILIATES, AND ITS LICENSORS, FOR ANY CLAIMS UNDER THESE TERMS, INCLUDING FOR ANY IMPLIED WARRANTIES, IS LIMITED TO THE AMOUNT PAID FOR THE UPS.

THIS SECTION 5.2 STATES EATON'S ENTIRE LIABILITY AND LICENSEE'S SOLE AND EXCLUSIVE REMEDY UNDER THIS AGREEMENT, AND IS SUBJECT TO ALL LIMITATIONS STATED IN SECTION 4.2.

**5.3 Notices.** All notices required to be sent hereunder will be in writing and will be deemed to

have been given when mailed by first class mail to the address shown below:

LICENSE NOTICES:  
Eaton Intelligent Power Limited  
Eaton House,  
30 Pembroke Road,  
Dublin 4,  
D04 Y0C2,  
Ireland

**5.4 Severability.** If any provision of this Agreement is held to be invalid or unenforceable, the remaining provisions of this Agreement will remain in full force.

**5.5 Waiver.** The waiver by either party of any default or breach of this Agreement will not constitute a waiver of any other or subsequent default or breach. Failure to enforce or delay in enforcing any provision of this Agreement will not constitute a waiver of any rights under any provisions of this Agreement.

**5.6 Entire Agreement.** This Agreement constitutes the complete agreement between the parties and supersedes all prior or contemporaneous agreements or representations, written or oral, concerning the subject matter of this Agreement. This Agreement may not be modified or amended except in a writing specifically referencing this Agreement and signed by a duly authorized representative of each party. No other act, document, usage or custom will be deemed to amend or modify this Agreement. The Firmware, or portions thereof, may also be subject to additional paper or electronic license agreements. In such cases, the terms of this Agreement will be supplemental to those in the additional agreements, to the extent not inconsistent with the additional agreements. If a copy of this Agreement in a language other than English is included with the Firmware or Documentation, it is included for convenience and the English language version of this Agreement will control.

**5.7 Heirs, Successors, and Assigns.** Each and all of the covenants, terms, provisions and agreements herein contained will be binding upon and inure to the benefit of the parties hereto and, to the extent expressly permitted by this Agreement, their respective heirs, legal representatives, successors and assigns.

**5.8 Export Restrictions.** Licensee agrees to comply fully with all relevant export laws and regulations of the United States and all other countries in the world (the "Export Laws") to assure that neither the Firmware nor any direct product thereof are (i) exported, directly or indirectly, in violation of Export Laws; or (ii) are intended to be used for any purposes prohibited by the Export Laws. Without limiting the foregoing, Licensee will not export or re-export the Firmware: (i) to any country to which the U.S. has embargoed or restricted the export of goods or services (see <http://www.treasury.gov/resource-center/sanctions/Programs/Pages/Programs.aspx>), or to any national of any such country, wherever located, who intends to transmit or transport the Firmware back to such country; (ii) to any end user who Licensee knows or has reason to know will utilize the Firmware in the design, development or production of nuclear, chemical or biological weapons; or (iii) to any end-user who has been prohibited from participating in U.S. export transactions by any federal agency of the U.S. government.

**5.9 U.S. Government Restricted Rights.** The Firmware is a "commercial item" as that term is defined at 48 C.F.R. § 2.101, consisting of "commercial computer software" and "commercial computer software documentation", as such terms are used in 48 C.F.R. § 12.212, and is provided to the U.S. Government only as a commercial end item. Consistent with 48 C.F.R. § 12.212 and 48 C.F.R. §§ 227.7202-1 through 227.7202-4, all U.S. Government End Users acquire the Firmware with only those rights set forth herein. Contractor/manufacturer is Eaton Corporation, 1000 Eaton Boulevard, Cleveland, Ohio 44122.

**5.10 Third Party Intellectual Property Rights.** The Firmware may contain components (including open source software components) that are owned by third parties ("Third Party Licensors") and are provided with, incorporated into, or embedded in, the Firmware pursuant to license arrangements between Eaton and such third parties. Third Party Licensor components in the Firmware are not licensed or warranted under the terms of this document, but are instead subject to the Third Party Licensors' license agreements. Licensee will not modify, delete, or obfuscate any copyright or other proprietary rights notices of Third Party Licensors contained in the Firmware.

**5.11 Indemnity.** Licensee shall defend, indemnify and hold Eaton and its officers, directors, employees, and agents harmless from and against all losses, damages, liabilities, claims, actions, and associated costs and expenses (including reasonable attorneys' fees and expenses) by reason of injury or death to any person or damage to any tangible or intangible property arising or resulting from the negligence or willful misconduct of the Licensee, its employees, contractors, or agents, in connection with Licensee's use of Firmware and Documentation.

Licensee shall be responsible for any breach of this Agreement by its officers, directors, employees, contractors, or agents. Licensee shall defend, indemnify, and hold Eaton and its officers, directors, employees, and agents harmless from and against any and all losses, damages, liabilities, claims, actions, and associated costs and expenses (including reasonable attorneys' fees and expenses) arising out of or in connection with any breach of this Agreement.

**5.12 Open Source Software.** The Firmware may contain certain components owned by Eaton that are provided with, incorporated into, linked to, or embedded in the Firmware that are subject to third party open source licenses ("Eaton Open Source Components"). Eaton Open Source Components are subject to the open source licenses corresponding to the particular software component. To the extent there are any conflicts between the terms of this Agreement and any open source license corresponding to Eaton Open Source Components or additional obligations by such open sources license that are not set forth in this Agreement, the terms of the open source license will control.

**5.13 Confidentiality.** Licensee acknowledges that confidential aspects of the Firmware (including any proprietary source code) are a trade secret of Eaton, the disclosure of which would cause substantial harm to Eaton that could not be remedied by the payment of damages alone and such confidential aspects of the Firmware shall not be disclosed to third parties without the prior written consent of Eaton. Accordingly, Eaton will be entitled to preliminary and permanent injunctive and other equitable relief for any breach of this Section 5.13.

**5.14 Note on JAVA Support.** The Firmware may contain support for programs written in JAVA. JAVA technology is not fault tolerant and is not designed, manufactured, or intended for use or resale as online control equipment in hazardous environments requiring fail-safe performance, such as in the operation of nuclear facilities, aircraft navigation or communications systems, air traffic control, direct life support machines, or weapons systems, in which the failure of JAVA technology could lead directly to death, personal injury, or severe physical or environmental damage. EATON DISCLAIMS ALL DAMAGES INCLUDING DIRECT, INDIRECT AND CONSEQUENTIAL DAMAGES RELATING TO THE FAILURE OF ANY SOFTWARE INCLUDING JAVA PROGRAMS AND/OR JAVA TECHNOLOGY.

**5.15 Governing Law.** This Agreement will be interpreted and enforced in accordance with the laws of Ireland, without regard to choice of law principles. Any claim or suit with respect to this Agreement shall be brought in the Courts of Ireland, unless mandatory law imposes otherwise.

Eaton EULA



# Table of Contents

<b>1 Introduction</b>	<b>1</b>
1.1 Installation Features	2
1.2 Optional Thermal Sensor	3
1.3 Model Configurations	3
1.4 Using This Manual	3
1.5 Conventions Used in This Manual	4
1.6 Symbols, Controls, and Indicators	4
1.7 For More Information	5
1.8 Getting Help	5
1.9 Equipment Registration	6
<b>2 Safety Warnings</b>	<b>7</b>
<b>3 Installation Plan and Unpacking</b>	<b>11</b>
3.1 Creating an Installation Plan	11
3.2 Preparing the Site	11
3.2.1 Environmental and Installation Considerations	11
3.2.2 IBC Power Wiring Preparation	19
3.2.3 IBC Interface Wiring Preparation	25
3.3 Inspecting and Unpacking the IBC	26
3.4 Battery Breaker Location	27
<b>4 Installation</b>	<b>29</b>
4.1 Preliminary Installation Information	29
4.2 Unloading the IBC Cabinet from the Pallet	29
4.3 Installing IBC Power Wiring	35
4.3.1 Line-Up-and-Match Power Wiring	35
4.3.2 Standalone Power Wiring	41
4.4 Battery Breaker Instantaneous Trip Setting	46
4.5 Installing IBC Interface Wiring	47
4.5.1 Installing Battery Detect Interface Connections	47
4.5.2 Installing Battery Shunt Trip Interface Connections	52
4.5.3 Installing Thermal Sensor Interface Connections	53
4.6 Initial Startup	55
4.7 Completing the Installation Checklist	55
4.8 Installation Checklist	55
<b>5 Onelines and Schematics</b>	<b>57</b>
5.1 Power Onelines	57
5.2 Interface Onelines	60
5.3 Schematics	61

# Table of Contents

<b>6 Maintenance</b> .....	<b>63</b>
6.1 Important Safety Instructions .....	63
6.2 Performing Preventive Maintenance .....	63
6.2.1 DAILY Maintenance .....	63
6.2.2 PERIODIC Maintenance .....	63
6.2.3 ANNUAL Maintenance.....	63
6.2.4 BATTERY Maintenance.....	63
6.2.5 BATTERY Shelf Life.....	64
6.3 Recycling the Used Batteries .....	64
6.4 Maintenance Training .....	64
<b>7 Product Specifications</b> .....	<b>65</b>
7.1 Model Numbers .....	65
7.2 Specifications .....	65
7.2.1 Battery Specifications .....	65
7.2.2 Environmental and Safety Specifications.....	66
<b>8 Warranty</b> .....	<b>67</b>

## List of Figures

Figure 1.	Eaton 93PM IBC-LW or Eaton 93PM IBC-LHW .....	1
Figure 2.	Typical Eaton 93PM UPS and Two Eaton 93PM Universal Integrated Battery Cabinets .....	2
Figure 3.	Eaton 93PM IBC-LW or Eaton 93PM IBC-LHW Dimensions (Front and Right Side Views) .....	15
Figure 4.	Eaton 93PM IBC-LW or Eaton 93PM IBC-LHW Dimensions (Rear Views) .....	16
Figure 5.	Eaton 93PM IBC-LW or Eaton 93PM IBC-LHW Dimensions (Top and Bottom Views) .....	17
Figure 6.	Eaton 93PM IBC-LW or Eaton 93PM IBC-LHW Center of Gravity .....	18
Figure 7.	Eaton 93PM IBC-LW or Eaton 93PM IBC-LHW as Shipped on Pallet .....	27
Figure 8.	Eaton 93PM IBC-LW or Eaton 93PM IBC-LHW Battery Breaker Location – Front View with Front Door Removed .....	28
Figure 9.	Removing the Pallet Skids and Supports – Eaton 93PM IBC-LW or Eaton 93PM IBC-LHW .....	31
Figure 10.	Line-Up-and-Match Wiring Access Locations .....	33
Figure 11.	Rear Ventilation .....	34
Figure 12.	Top Ventilation .....	34
Figure 13.	DC Power Terminal Shield Location .....	36
Figure 14.	DC Power Terminal Locations – Eaton 93PM IBC-LW or Eaton 93PM IBC-LHW .....	38
Figure 15.	DC Power Terminal — Bottom Wiring Entry Terminal Installation .....	39
Figure 16.	DC Power Terminal Detail – Eaton 93PM IBC-LW or Eaton 93PM IBC-LHW .....	40
Figure 17.	DC Power Terminal — Top Wiring Entry Terminal Installation .....	42
Figure 18.	Battery Breaker Mount Screw Location and Mount Lever Location - Eaton 93PM IBC .....	43
Figure 19.	DC Power Terminal Shield .....	44
Figure 20.	IBC Bottom Entry Conduit and Wire Entry Locations .....	45
Figure 21.	IBC Top Entry Conduit and Wire Entry Locations .....	46
Figure 22.	Battery Breaker Instantaneous Trip Setting Dials .....	47
Figure 23.	Interface Terminal Locations – Eaton 93PM IBC-LW or Eaton 93PM IBC-LHW .....	49
Figure 24.	Shunt Trip and Battery Detect Wiring .....	50
Figure 25.	Interface Terminal Detail – Eaton 93PM IBC-LW or Eaton 93PM IBC-LHW .....	51
Figure 26.	Eaton 93PM IBC-LW Line-Up-and-Match Power Online .....	57
Figure 27.	Eaton 93PM IBC-LW Standalone Power Online – One or Two Cabinets .....	58
Figure 28.	Eaton 93PM IBC-LW Standalone Power Online – Four Cabinets .....	58
Figure 29.	Eaton 93PM IBC-LHW Line-Up-and-Match Power Online .....	59
Figure 30.	Eaton 93PM IBC-LHW Standalone Power Online – One Cabinet .....	59
Figure 31.	Eaton 93PM IBC-LHW Standalone Power Online – Two Cabinets .....	60
Figure 32.	Eaton 93PM Universal Integrated Battery Cabinet Interface Online .....	61
Figure 33.	Eaton 93PM Universal Integrated Battery Cabinet Schematic .....	62

List of Figures



## List of Tables

Table 1.	Eaton 93PM IBC-LW (432V) Cabinet Weights .....	12
Table 2.	Eaton 93PM IBC-LHW (432V) Cabinet Weights .....	13
Table 3.	Eaton 93PM IBC-LW (480V) Cabinet Weights .....	13
Table 4.	Eaton 93PM IBC-LHW (480V) Cabinet Weights .....	13
Table 5.	Eaton 93PM IBC-LW and Eaton 93PM IBC-LHW Cabinet Clearances .....	14
Table 6.	Line-Up-and-Match External Power Wiring Recommendations – Eaton 93PM IBC-LW and Eaton 93PM IBC-LHW .....	20
Table 7.	Standalone External Power Wiring Recommendation – Eaton 93PM IBC-LW (300A Breaker) .....	21
Table 8.	Standalone External Power Wiring Recommendations – Eaton 93PM IBC-LW (400A Breaker) .....	22
Table 9.	Standalone External Power Wiring Recommendations – Eaton 93PM IBC-LHW (500A Breaker) .....	23
Table 10.	External Power Cable Terminations – Eaton 93PM IBC-LW and Eaton 93PM IBC-LHW .....	24
Table 11.	Recommended DC Circuit Breaker or Disconnect Ratings (Three or Four IBC-LWs or Two IBC-LHWs) .....	25
Table 12.	Eaton 93PM IBC-LW or Eaton 93PM IBC-LHW – TB2 Interface Connections .....	49
Table 13.	Eaton 93PM IBC-LW or Eaton 93PM IBC-LHW – TB2 Interface Wiring Terminal Block Terminations .....	51

List of Tables

## Chapter 1 Introduction

The Eaton® Eaton 93PM Universal Integrated Battery Cabinet-Large (IBC-LW) and Universal Integrated Battery Cabinet-Large High Rate (IBC-LHW) provide extended emergency short-time backup power for the Eaton 93PM Uninterruptible Power Supply (UPS) systems to enhance the usability and reliability of the systems. The IBC-LW and IBC-LHW safeguard operation during brownouts, blackouts, and other power interruptions providing cost-effective extended battery run time. In addition, the IBC-LHW provides a single battery cabinet solution for Eaton 93PM and 93PM-L UPS systems 200 kW and below. Eaton 93PM 400 kW UPS systems above 200 kW require at least two battery cabinets.

The IBC-LW and IBC-LHW are housed in a single free-standing cabinet with a safety shield behind the front door for hazardous voltage protection. UPS systems 200 kW and below can utilize up to four IBC-LWs per UPS or two IBC-LHWs per UPS to meet application runtime needs. 400 kW UPS systems can utilize up to eight IBC-LWs per UPS or four IBC-LHWs per UPS to meet application runtime needs. The cabinets match the UPS cabinet in style and color.

The IBCs are equipped with valve-regulated lead-acid (VRLA) batteries. Removable battery trays with quick disconnects between trays reduce battery maintenance time. A DC-rated circuit breaker within each cabinet provides protection and servicing isolation. The IBC-LHW is available with battery voltage of 432 or 480 Vdc.

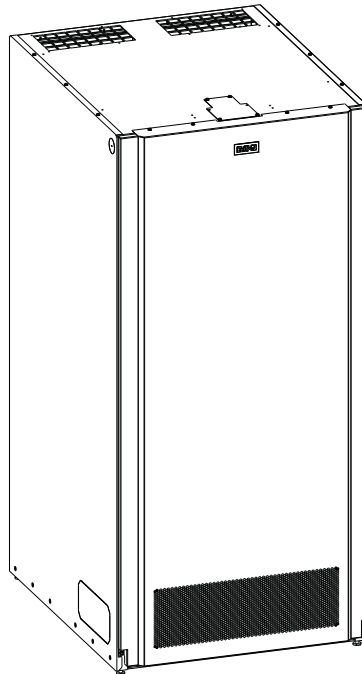
[Figure 1](#) shows the Eaton 93PM IBC-LW or Eaton 93PM IBC-LHW.

---

**NOTE** Startup and operational checks must be performed by an authorized Eaton Customer Service Engineer, or the warranty terms specified on the product's resources page become void. See [Chapter 8 Warranty](#) for details. This service is offered as part of the sales contract for the UPS. Contact an Eaton service representative in advance (a minimum two-week notice is required) to reserve a preferred startup date.

---

**Figure 1. Eaton 93PM IBC-LW or Eaton 93PM IBC-LHW**

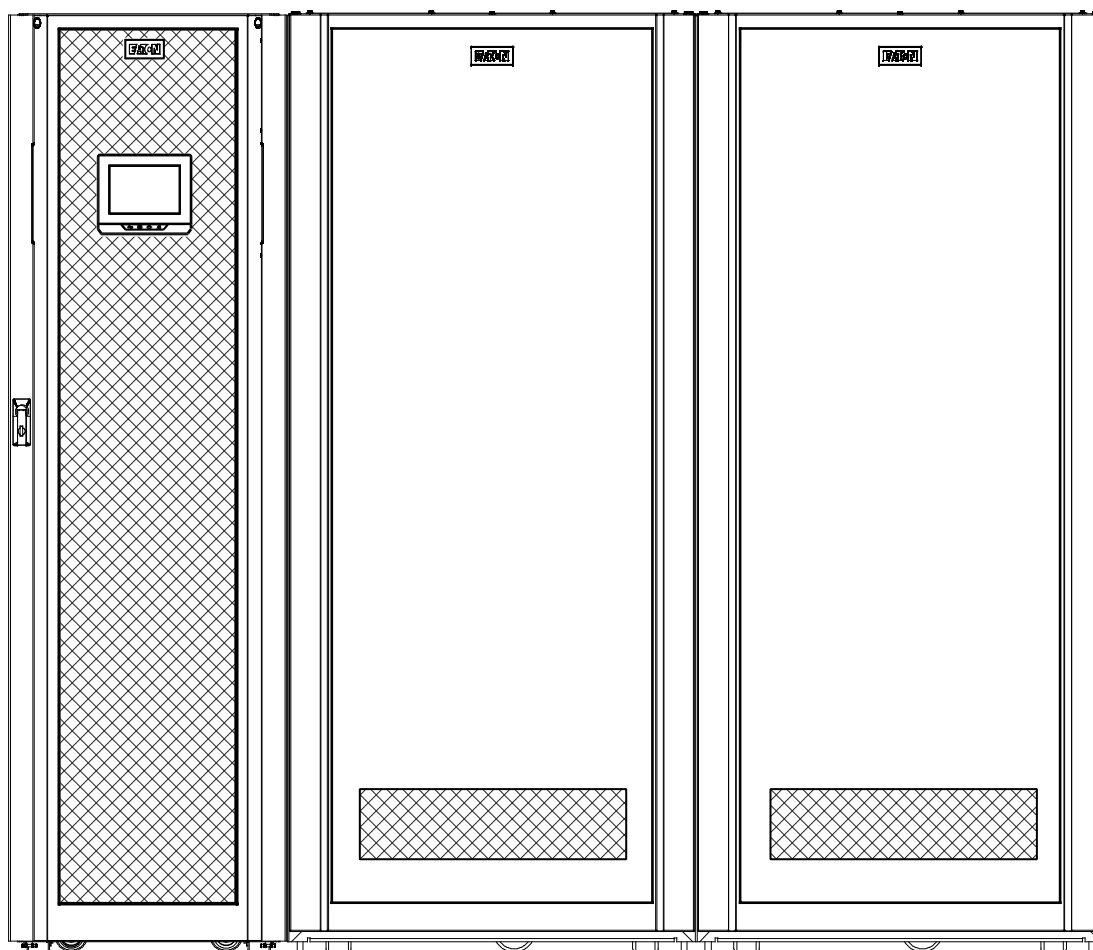


## 1.1 Installation Features

- Line-up-and-match configurations using factory supplied power wiring or standalone configurations using customer supplied power wiring.
- Battery wiring can be run internally through the left or right sides of the IBCs in line-up-and-match configurations or routed through the top or bottom of the IBCs using conduit in standalone configurations.
- Easily accessible mechanical terminals located at the bottom front of the cabinet reduce installation time.
- Interface wiring can be routed through the top left or right sides of the IBCs in line-up-and-match configurations or through the top or bottom of the IBCs using conduit in standalone configurations.
- IBCs can be installed in a single lineup.
- Built-in casters for easy cabinet placement.

Line-up-and-match battery cabinets are installed adjacent to the UPS. The recommended installation location is on the right side of the UPS cabinet as viewed from the front of the cabinet. See [Figure 2](#) for line-up-and-match configuration view.

**Figure 2. Typical Eaton 93PM UPS and Two Eaton 93PM Universal Integrated Battery Cabinets**



## 1.2 Optional Thermal Sensor

Thermal runaway protection for VRLA batteries can be provided by installing an optional thermal sensor inside the battery cabinet.

The sensor is wired to an UPS building alarm programmed to turn the charger off when a trip signal is received.

The thermal sensor will maintain the trip state until the temperature it is reset by service. Service should be called to inspect the batteries and reset the sensor in case of such an event.

## 1.3 Model Configurations

The following model configurations are available:

- Eaton 93PM Universal Integrated Battery Cabinet-Large (432V and 480V)
  - Line-up-and-match, top or bottom entry standalone.
  - Contains one battery string to be used with Eaton 93PM UPS systems.
  - Available B37, E28, E39, E54, N54, or H41 batteries.
  - Up to four IBC-LWs can be paralleled to extend the run time. Use with a Eaton 93PM-L 20-120 kW (208V) UPS. Use with a Eaton 93PM 20-50 kW UPS, Eaton 93PM 20-100 kW UPS, Eaton 93PM 20-150 kW UPS, or Eaton 93PM 20-200 kW UPS.
  - Up to eight IBC-LWs can be paralleled to extend the run time. Use with a Eaton 93PM 100-400 kW UPS.
- Eaton 93PM Universal Integrated Battery Cabinet-Large High Rate (432V and 480V)
  - Line-up-and-match, top or bottom entry standalone.
  - Contains one battery string to be used with Eaton 93PM UPS systems.
  - Available B37, E54, N54 or H41 batteries.
  - Up to two IBC-LHWs can be paralleled to extend the run time. Use with a Eaton 93PM-L 20-120 kW (208V) UPS. Use with a Eaton 93PM 20-50 kW UPS, Eaton 93PM 20-100 kW UPS, Eaton 93PM 20-150 kW UPS, or Eaton 93PM 20-200 kW UPS.
  - Up to four IBC-LHWs can be paralleled to extend the run time. Use with a Eaton 93PM 100-400 kW UPS.



### NOTE

The Eaton IBC-LW or IBC-LHW 480 Vdc version is required when using the 480V Four Wire 93PM UPS systems.

---

## 1.4 Using This Manual

This manual describes how to install the IBC and is divided into chapters. Read and understand the procedures described to ensure trouble-free installation and operation.

Read through each procedure before beginning the procedure. Perform only those procedures that apply to the UPS system being installed or operated.

## 1.5 Conventions Used in This Manual

This manual uses these type conventions:

- **Bold type** highlights important concepts in discussions, key terms in procedures, and menu options, or represents a command or option that you type or enter at a prompt.
- *Italic type* highlights notes and new terms where they are defined.
- `Screen type` represents information that appears on the screen or LCD.

Icon	Description
<b>Note</b>	Information notes call attention to important features or instructions.
[Keys]	Brackets are used when referring to a specific key, such as [Enter] or [Ctrl].

In this manual, the term UPS refers only to the UPS cabinet and its internal elements. The term UPS system refers to the entire power protection system – the UPS cabinet, an external battery system, and options or accessories installed.

The term line-up-and-match refers to accessory cabinets that are physically located adjacent to the UPS. The term standalone refers to accessory cabinets that are located separate from the UPS.

Left and right side notations are referenced standing in front of the cabinet.

## 1.6 Symbols, Controls, and Indicators

The following are examples of symbols used on the UPS or accessories to alert you to important information:



**RISK OF ELECTRIC SHOCK** - Observe the warning associated with the risk of electric shock symbol.



**CAUTION: REFER TO OPERATOR'S MANUAL** - Refer to your operator's manual for additional information, such as important operating and maintenance instructions.



This symbol indicates that you should not discard the UPS or the UPS batteries in the trash. This product contains sealed, lead-acid batteries and must be disposed of properly. For more information, contact your local recycling/reuse or hazardous waste center.



This symbol indicates that you should not discard waste electrical or electronic equipment (WEEE) in the trash. For proper disposal, contact your local recycling/reuse or hazardous waste center.

## 1.7 For More Information

Refer to the following manuals for the information listed below:

- *Eaton 93PM-L UPS (20–60 kW, 208V) Installation and Operation Manual*
  - *Eaton 93PM-L UPS (20–120 kW, 208V) Installation and Operation Manual*
  - *Eaton 93PM-L UPS (20–160 kW, 208V) Installation and Operation Manual*
  - *Eaton 93PM-L UPS (20–200 kW, 208V) Installation and Operation Manual*
  - *Eaton 93PM UPS 480V Three-Wire – 50 kW Frame Installation and Operation Manual*
  - *Eaton 93PM UPS 400V/480V Four-Wire – 50 kW Frame Installation and Operation Manual*
  - *Eaton 93PM UPS 480V Three-Wire – 100 kW Frame Installation and Operation Manual*
  - *Eaton 93PM UPS 400V/480V Four-Wire – 100 kW Frame Installation and Operation Manual*
  - *Eaton 93PM UPS 480V Three-Wire 150 kW Frame Installation and Operation Manual*
  - *Eaton 93PM UPS 400V/480V Four-Wire – 150 kW Frame Installation and Operation Manual*
  - *Eaton 93PM UPS 480V Three-Wire – 200 kW Frame Installation and Operation Manual*
  - *Eaton 93PM UPS 400V/480V Four-Wire – 200 kW Frame Installation and Operation Manual*
  - *Eaton 93PM UPS 480V Three-Wire – 400 kW Frame Installation and Operation Manual*
1. UPS, optional components, and accessory installation instructions, including site preparation, planning for installation, and wiring and safety information. Detailed illustrations of cabinets and optional accessories with dimensional and connection point drawings are provided.
  2. UPS operation, including UPS controls, functions of the UPS, standard features and optional accessories, procedures for starting and stopping the UPS, and information about maintenance and responding to system events.
  3. Communication capabilities of the UPS system.

Visit [www.eaton.com/powerquality](http://www.eaton.com/powerquality) or contact an Eaton service representative for information on how to obtain copies of these manuals.

## 1.8 Getting Help

If help is needed with any of the following:

- Scheduling initial startup
- Regional locations and telephone numbers
- A question about any of the information in this manual
- A question this manual does not answer

Please call the Customer Reliability Center at:

United States:	<b>1-800-843-9433</b>
Canada:	<b>1-800-461-9166 ext 260</b>
All other countries:	<b>Call your local service representative</b>

Please use the following e-mail address for manual comments, suggestions, or to report an error in this manual: **E-ESSDocumentation@eaton.com**

## 1.9 Equipment Registration

Please visit [www.eaton.com/pg/register](http://www.eaton.com/pg/register) to register your new Eaton UPS / Eaton UPS Accessory.

**Model Number:**

---

**Serial Number:**

---



## Chapter 2 Safety Warnings

---

### IMPORTANT SAFETY INSTRUCTIONS SAVE THESE INSTRUCTIONS

---

This manual contains important instructions that should be followed during installation and maintenance of the UPS system and batteries. Read all instructions before operating the equipment and save this manual for future reference.

The UPS system is designed for industrial or computer room applications, and contains safety shields behind the door and front panels. However, the UPS system is a sophisticated power system and should be handled with appropriate care.

---

 **DANGER**

---

This UPS system contains LETHAL VOLTAGES. All repairs and service should be performed by AUTHORIZED SERVICE PERSONNEL ONLY. There are NO USER SERVICEABLE PARTS inside the UPS.

---

 **WARNING**

---

- The UPS system is powered by its own energy source (batteries). The output terminals may carry live voltage even when the UPS is disconnected from an AC source.
  - The battery cabinet contains its own energy source. The internal wiring and output terminals may carry live voltage even when the UPS is not connected to an AC source.
  - To reduce the risk of fire or electric shock, install this UPS system in a temperature and humidity controlled, indoor environment, free of conductive contaminants. Ambient temperature must not exceed 40°C (104°F). Do not operate near water or excessive humidity (95% maximum). The system is not intended for outdoor use.
  - As a result of the connected loads high leakage current is possible. Connection to earth ground is required for safety and proper product operation. Do not check UPS system operation by any action that includes removal of the earth (ground) connection with loads attached.
  - Ensure all power is disconnected before performing installation or service.
  - Batteries can present a risk of electrical shock or burn from high short-circuit current. The following precautions should be observed: 1) Remove watches, rings, or other metal objects; 2) Use tools with insulated handles; 3) Do not lay tools or metal parts on top of batteries; 4) Wear voltage rated gloves and electrical hazard footwear.
  - ELECTRIC ENERGY HAZARD. Do not attempt to alter any UPS system or battery wiring or connectors. Attempting to alter wiring can cause injury.
  - Do not open or mutilate batteries. Released electrolyte is harmful to the skin and eyes. It may be toxic.
-

---

 **CAUTION**

---

- Installation or servicing should be performed by qualified service personnel knowledgeable of UPS and battery systems, and required precautions. Keep unauthorized personnel away from equipment. Consider all warnings, cautions, and notes before installing or servicing equipment. **DO NOT DISCONNECT** the batteries while the UPS is in Battery mode.
- Batteries may only be replaced with the same number and type by authorized service personnel. No user serviceable parts.
- The UPS system has been evaluated for use with a maximum of four 93PM EBCs. Use of any other configuration may result in fire, death, and voiding of the warranty.
- Disconnect the charging source prior to connecting or disconnecting battery terminals.
- Determine if the battery is inadvertently grounded. If it is, remove the source of the ground. Contacting any part of a grounded battery can cause a risk of electric shock. An electric shock is less likely if you disconnect the grounding connection before you work on the batteries.
- Proper disposal of batteries is required. Refer to local codes for disposal requirements.
- Do not dispose of batteries in a fire. Batteries may explode when exposed to flame.
- Keep the Accessory cabinet doors closed and front panels installed to ensure proper cooling airflow and to protect personnel from dangerous voltages inside the unit.
- Do not install or operate the UPS system close to gas or electric heat sources.
- Lead-acid batteries can present a risk of fire because they generate hydrogen gas. Do not smoke when near batteries. Do not cause flame or spark in battery area. Discharge static electricity from body before touching batteries by first touching a grounded metal surface.
- The operating environment should be maintained within the parameters stated in this manual.
- Operating temperatures above the recommended range will result in decreased battery life and performance, and will reduce or void the battery warranty. Refer to Terms and Conditions of Sale with Battery Replacement Coverage and the Battery Replacement Price Book for more information. These documents can be found at [www.eaton.com/powerquality](http://www.eaton.com/powerquality) or contact your service representative for information on how to obtain copies.
- The shelf life for the batteries installed in the IBC is 12 months from the date code on the battery. The recharge date is also stated on a label inside the IBC.  
Failure to recharge the batteries before the expiration of the shelf life will result in reduced discharge time, shorter float service life, and will void the warranty.
- Keep surroundings uncluttered, clean, and free from excess moisture.
- Observe all DANGER, CAUTION, and WARNING notices affixed to the inside and outside of the equipment.

---

 **AVERTISSEMENT!**

---

- Les batteries peuvent présenter un risque de décharge électrique ou de brûlure par des courts-circuits de haute intensité. Prendre les précautions nécessaires.
  - Pour le remplacement, utiliser le même nombre et modèle des batteries.
-

**ATTENTION!**

---

- Une mise au rebut réglementaire des batteries est obligatoire. Consulter les règlements en vigueur dans votre localité.
  - Ne jamais jeter les batteries au feu. L'exposition aux flammes risque de les faire exploser.
  - Les accumulateurs au plomb-acide peuvent représenter un risque d'incendie, car ils génèrent de l'hydrogène gazeux. Ne pas fumer près des accumulateurs. Ne pas produire de flamme ou d'étincelle dans la zone de l'accumulateur. Dissiper l'électricité statique de votre corps en touchant une surface reliée à la terre avant de toucher les accumulateurs.
-

## Safety Warnings

## Chapter 3 Installation Plan and Unpacking

Use the following basic sequence of steps to install the Eaton 93PM Universal Integrated Battery Cabinet-Large (IBC-LW) or Universal Integrated Battery Cabinet-Large High Rate (IBC-LHW):

1. Create an installation plan for the IBC.
2. Prepare your site for the IBC.
3. Inspect and unpack the IBC.
4. Unload and install the IBC, and wire the system.
5. Complete the Installation Checklist.
6. Have authorized service personnel perform preliminary operational checks and start up the system.



---

**NOTE**

Startup and operational checks must be performed by an authorized Eaton Customer Service Engineer, or the warranty terms specified on the product's resources page become void. See [Chapter 8 Warranty](#) for details. This service is offered as part of the sales contract for the UPS. Contact an Eaton service representative in advance (a minimum two-week notice is required) to reserve a preferred startup date.

---

### 3.1 Creating an Installation Plan

Before installing the IBC, read and understand how this manual applies to the system being installed. Use the procedures and illustrations in this section to create a logical plan for installing the IBC. This section contains the following information:

- Physical features and requirements, including dimensions
- Power wiring installation notes
- Location of conduit and wire entry landing plates
- Location of power terminals

### 3.2 Preparing the Site

For the UPS system to operate at peak efficiency, the installation site should meet the environmental parameters outlined in this manual. The operating environment must meet the weight, clearance, and environmental requirements specified.

#### 3.2.1 Environmental and Installation Considerations

The UPS system installation, including the IBC, must meet the following guidelines:

- The system must be installed on a level floor suitable for computer or electronic equipment.
- The system must be operated at an altitude no higher than 1500m (5000 ft) without derating. For additional information and assistance with high altitude operation, contact an Eaton service representative (see paragraph [1.8 Getting Help](#)).
- The system must be installed in a temperature and humidity controlled indoor area free of conductive contaminants.
- Specifications are subject to change.

Failure to follow guidelines may void your warranty.

The basic environmental requirements for operation of the IBC are:

- The battery cabinet is rated for operation in up to a 40°C (104°F) ambient temperature.



**NOTE**

Emergency lighting and power equipment battery cabinets (UL924) are rated for operation in a 20°–30°C (68°–86°F) temperature environment.

- The batteries are rated for a 25°C (77°F) ambient temperature to extend their useful life.
- Maximum Relative Humidity: 5–95%, noncondensing



**CAUTION**

It is recommended for optimal battery life and discharge performance to keep the ambient air temperature the battery is used in at 25°C (77°F). Operating temperatures above the recommended range will result in decreased battery life and performance, and will reduce or void the battery warranty. Refer to Eaton's Terms and Conditions of Sale with Battery Replacement Coverage and the Battery Replacement Price Book for more information. These documents can be found at [www.eaton.com/powerquality](http://www.eaton.com/powerquality) or contact your service representative for information on how to obtain copies.

The IBC operating environment must meet the weight requirements shown in [Table 1](#), [Table 2](#), [Table 3](#) or [Table 4](#) and the size requirements shown in [Figure 3](#) through [Figure 6](#). Dimensions are in millimeters (inches). Specifications are subject to change.

**Table 1. Eaton 93PM IBC-LW (432V) Cabinet Weights**

Model	Weight kg (lb)		
	Shipping	Installed	Point Loading
Eaton 93PM Universal Integrated Battery Cabinet-Large with E28 Batteries	1430 (3154)	1385 (3054)	6 at 231 (509)
Eaton 93PM Universal Integrated Battery Cabinet-Large with E39 Batteries	1732 (3820)	1687 (3720)	6 at 281 (620)
Eaton 93PM Universal Integrated Battery Cabinet-Large with E54 Batteries	2034 (4486)	1989 (4386)	6 at 332 (731)
Eaton 93PM Universal Integrated Battery Cabinet-Large with B37 Batteries	1762 (3885)	1717 (3785)	6 at 286 (631)
Eaton 93PM Universal Integrated Battery Cabinet-Large with H41 Batteries	1719 (3791)	1674 (3691)	6 at 279 (615)
Eaton 93PM Universal Integrated Battery Cabinet-Large with N54 Batteries	2055 (4531)	2010 (4431)	6 at 335 (739)

**Table 2. Eaton 93PM IBC-LHW (432V) Cabinet Weights**

Model	Weight kg (lb)		
	Shipping	Installed	Point Loading
Universal Integrated Battery Cabinet-Large High Rate with B37 Batteries	1795 (3957)	1750 (3857)	6 at 292 (643)
Universal Integrated Battery Cabinet-Large High Rate with E54 Batteries	2067 (4558)	2022 (4458)	6 at 337 (743)
Universal Integrated Battery Cabinet-Large High Rate with H41 Batteries	1752 (3863)	1707 (3763)	6 at 285 (627)
Universal Integrated Battery Cabinet-Large High Rate with N54 Batteries	2088 (4605)	2043 (4505)	6 at 341 (751)

**Table 3. Eaton 93PM IBC-LW (480V) Cabinet Weights**

Model	Weight kg (lb)		
	Shipping	Installed	Point Loading
Eaton 93PM Universal Integrated Battery Cabinet-Large with E54 Batteries	2224 (4903)	2179 (4803)	6 at 363 (801)
Eaton 93PM Universal Integrated Battery Cabinet-Large with E39 Batteries	1881 (4148)	1836 (4048)	6 at 306 (675)
Eaton 93PM Universal Integrated Battery Cabinet-Large with E28 Batteries	1545 (3408)	1500 (3308)	6 at 250 (551)
Eaton 93PM Universal Integrated Battery Cabinet-Large with B37 Batteries	1921 (4236)	1876 (4136)	6 at 313 (689)
Eaton 93PM Universal Integrated Battery Cabinet-Large with H41 Batteries	1874 (4132)	1829 (4032)	6 at 305 (672)
Eaton 93PM Universal Integrated Battery Cabinet-Large with N54 Batteries	2247 (4955)	2202 (4855)	6 at 367 (809)

**Table 4. Eaton 93PM IBC-LHW (480V) Cabinet Weights**

Model	Weight kg (lb)		
	Shipping	Installed	Point Loading
Universal Integrated Battery Cabinet-Large High Rate with N54 Batteries	2273 (5013)	2228 (4913)	6 at 371(819)
Universal Integrated Battery Cabinet-Large High Rate with H41 Batteries	1900 (4189)	1855 (4089)	6 at 309 (682)
Universal Integrated Battery Cabinet-Large High Rate with E54 Batteries	2250 (4961)	2205 (4861)	6 at 368 (810)
Universal Integrated Battery Cabinet-Large High Rate with B37 Batteries	1947 (4293)	1902 (4193)	6 at 317 (699)

The IBCs use natural convection cooling to regulate internal component temperature. Air inlets are in the front of the cabinet and outlets are on the back or top of the cabinet. Allow clearance in front of, and on back or top of the cabinet for proper air circulation. The clearances required around the IBC cabinet are shown in [Table 5](#).

**Table 5. Eaton 93PM IBC-LW and Eaton 93PM IBC-LHW Cabinet Clearances**

<b>From Top of Cabinet with Rear Exhaust Option</b>	304.8 mm (12") working space
<b>From Top of Cabinet with Top Exhaust Option</b>	304.8 mm (12") minimum clearance for ventilation
<b>From Front of Cabinet</b>	914.4 mm (36") working space
<b>From Back of Cabinet with Top Exhaust Option</b>	None Required
<b>From Back of Cabinet with Rear Exhaust Option</b>	254 mm (10") minimum clearance for ventilation
<b>From Back of Cabinet – Seismic Installation</b>	914.4 mm (36") working space
<b>From Right Side of Cabinet</b>	None Required
<b>From Left Side of Cabinet</b>	None Required

---

 **CAUTION**

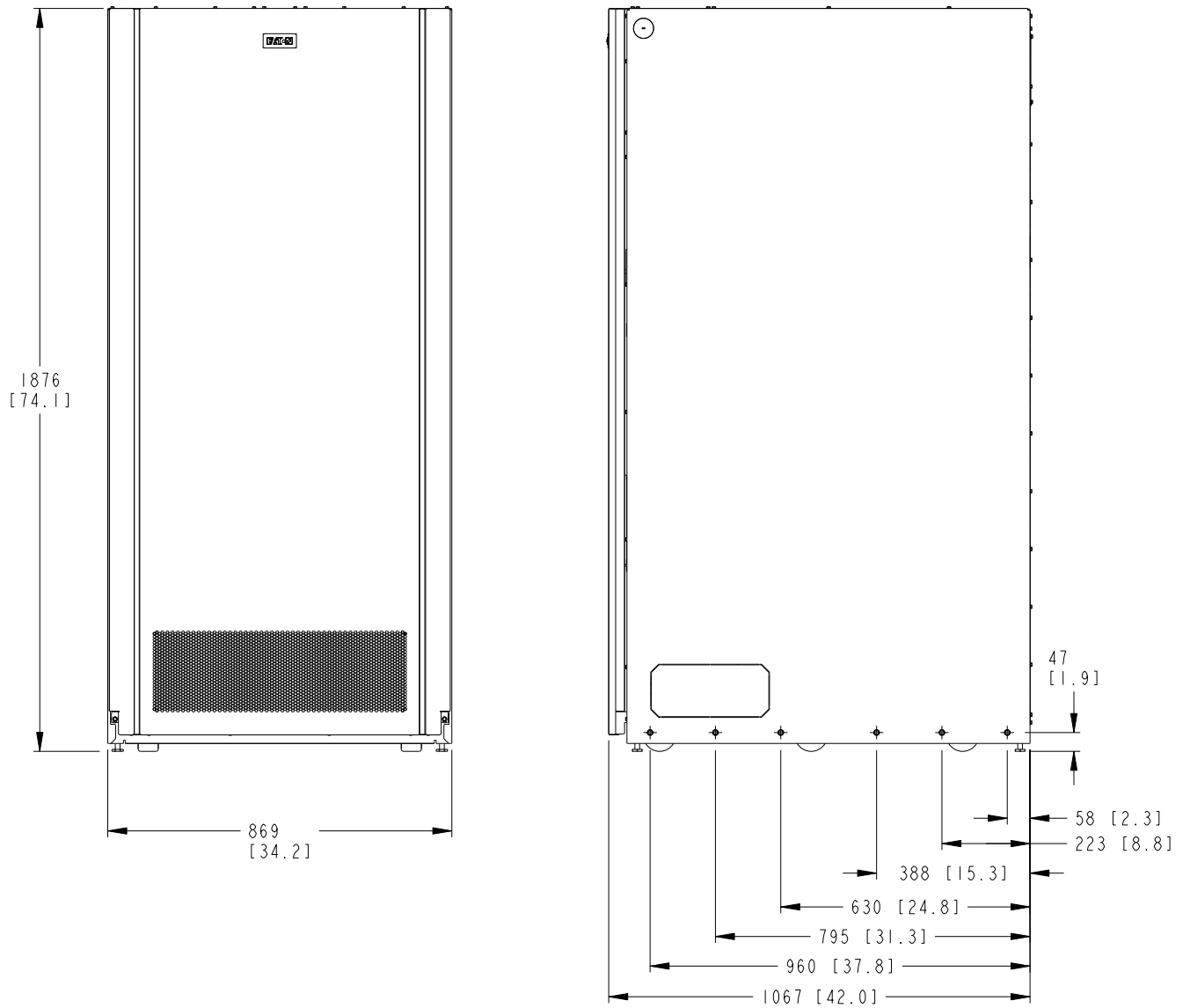
The shelf life for the batteries installed in the IBC are 6 months from the date code on the battery for the B37 batteries, 8 months from the date code on the battery for the E28, E39 and E54 batteries and 24 months from the date code on the battery for the N54 and H41 batteries. The recharge date is also stated on a label inside the IBC.

Failure to recharge the batteries before the expiration of the shelf life will result in reduced discharge time, shorter float service life, and will void the warranty.

---

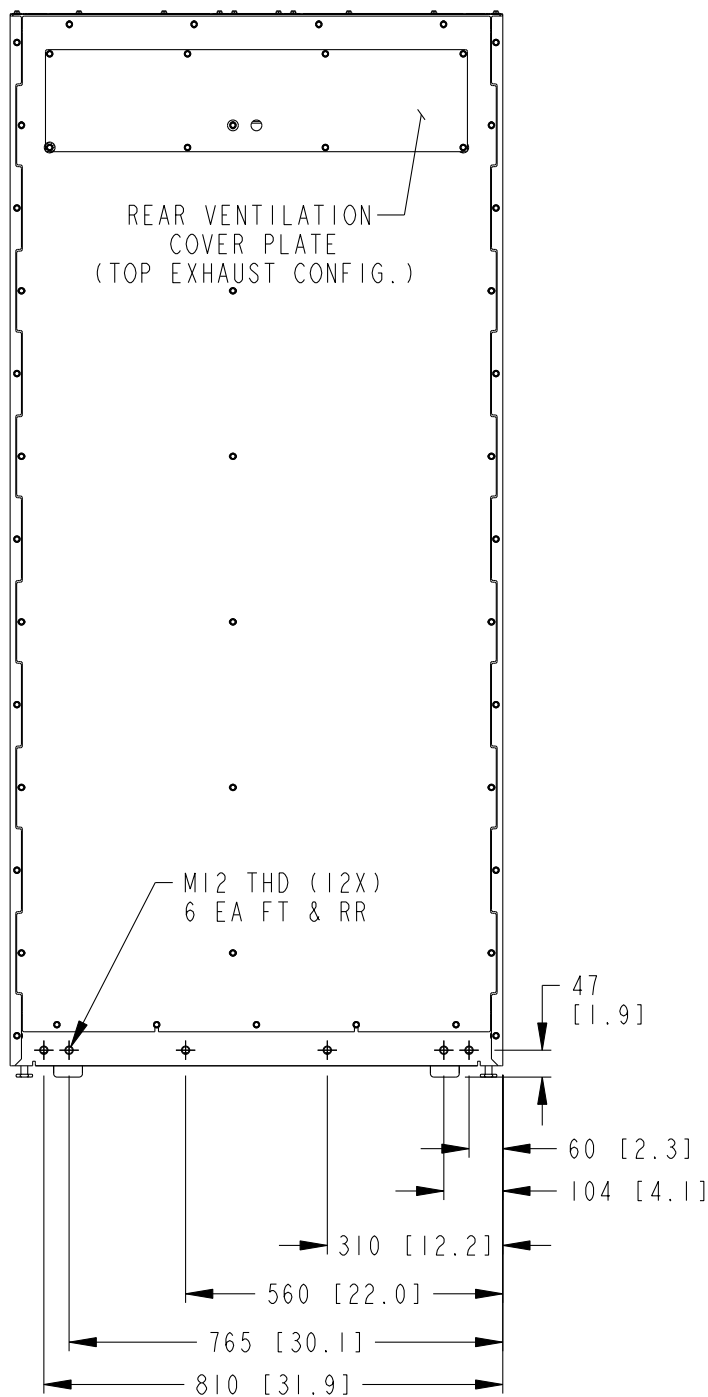


Figure 3. Eaton 93PM IBC-LW or Eaton 93PM IBC-LHW Dimensions (Front and Right Side Views)



Dimensions are in millimeters [inches]

**Figure 4. Eaton 93PM IBC-LW or Eaton 93PM IBC-LHW Dimensions (Rear Views)**



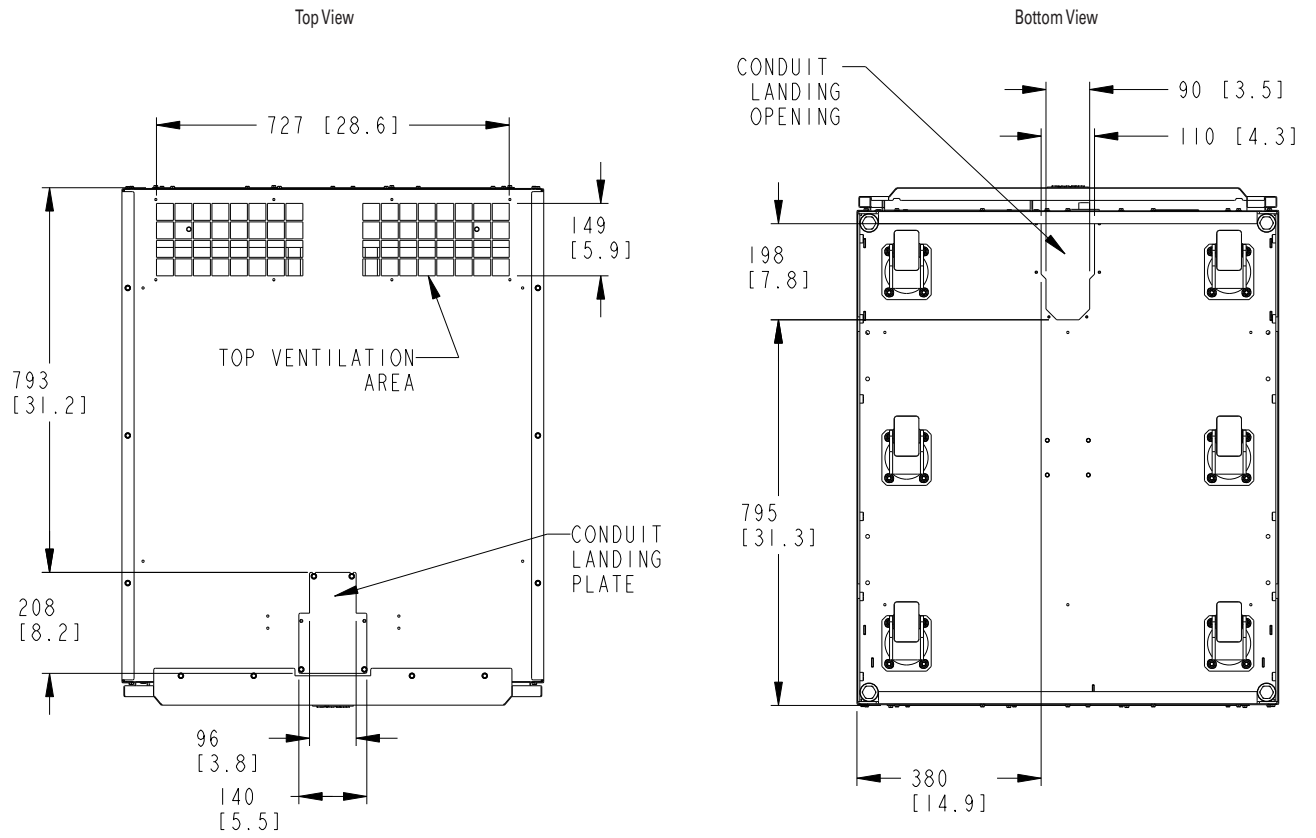
Dimensions are in millimeters [inches]



**NOTE**

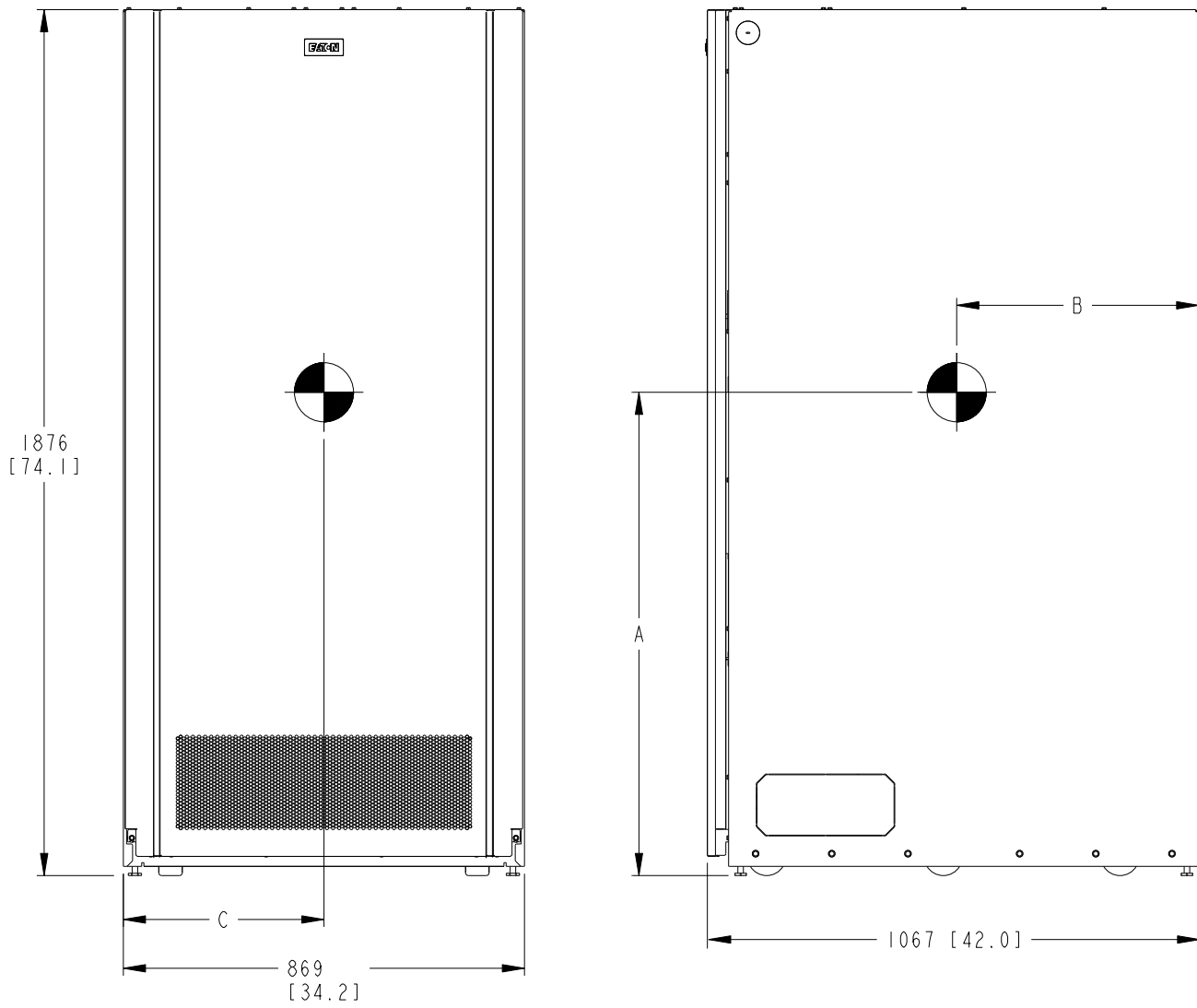
The IBC Front Floor Mounting Bracket's mounting dimensions are identical to the Rear Floor Mounting Bracket dimensions.

**Figure 5. Eaton 93PM IBC-LW or Eaton 93PM IBC-LHW Dimensions (Top and Bottom Views)**



Dimensions are in millimeters [inches]

Figure 6. Eaton 93PM IBC-LW or Eaton 93PM IBC-LHW Center of Gravity



Dimensions are in millimeters [inches]

<b>Weight and Center of Gravity (letters A, B, and C map to <a href="#">Figure 6</a>)</b>						
<b>Models</b>		<b>Dimensions</b>			<b>Installed Weight kg (lb)</b>	
		<b>A mm (in)</b>	<b>B mm (in)</b>	<b>C mm (in)</b>		
432V	IBC-LW	with 75Ah Batteries (E28)	1019 (40.1)	509 (20.0)	454 (17.9)	1385 (3054)
		with 100Ah Batteries (E39)	1031 (40.6)	507 (20.0)	455 (17.9)	1687 (3720)
		with 135Ah Batteries (E54)	1038 (40.9)	506 (19.9)	456 (18.0)	1989 (4386)
		with 103Ah Batteries (B37)	1029 (40.5)	508 (20.0)	455 (17.9)	1717 (3785)
		with 95Ah Batteries (H41)	1027 (40.4)	508 (20.0)	455 (17.9)	1674 (3691)
	IBC-LHW	with 125Ah Batteries (N54)	1036 (40.8)	506 (19.9)	456 (18.0)	2010 (4431)
		with 103Ah Batteries (B37)	1029 (40.5)	508 (20.0)	455 (17.9)	1750 (3857)
		with 95Ah Batteries (H41)	1027 (40.4)	508 (20.0)	455 (17.9)	1707 (3763)
		with 125Ah Batteries (N54)	1036 (40.8)	506 (19.9)	456 (18.0)	2043 (4505)
		with 135Ah Batteries (E54)	1036 (40.8)	506 (19.9)	456 (18.0)	2022 (4458)
480V	IBC-LW	with 75Ah Batteries (E28)	969 (38.1)	508 (20.0)	434 (17.1)	1500 (3308)
		with 100Ah Batteries (E39)	977 (38.5)	507 (20.0)	434 (17.1)	1836 (4048)
		with 135Ah Batteries (E54)	982 (38.7)	505 (19.9)	434 (17.1)	2179 (4803)
		with 103Ah Batteries (B37)	975 (38.4)	507 (20.0)	434 (17.1)	1876 (4136)
		with 95Ah Batteries (H41)	957 (38.4)	507 (20.0)	434 (17.1)	1829 (4032)
	IBC-LHW	with 125Ah Batteries (N54)	981 (38.6)	506 (19.9)	434 (17.1)	2202 (4855)
		with 103Ah Batteries (B37)	975 (38.4)	507 (20.0)	434 (17.1)	1902 (4193)
		with 95Ah Batteries (H41)	975 (38.4)	507 (20.0)	434 (17.1)	1855 (4089)
		with 125Ah Batteries (N54)	981 (38.6)	506 (19.9)	434 (17.1)	2228 (4913)
		with 135Ah Batteries (E54)	980 (38.6)	506 (19.9)	434 (17.1)	2205 (4861)

### 3.2.2 IBC Power Wiring Preparation

Read and understand the following notes while planning and performing the installation:

#### **WARNING**

As a result of the connected loads high leakage current is possible. Connection to earth ground is required for safety and proper product operation. Do not check IBC operation by any action that includes removal of the earth (ground) connection with loads attached.

- Refer to national and local electrical codes for acceptable external wiring practices.
- Material and labor for external wiring requirements are to be provided by the customer.
- For external wiring, use 75°C copper wire.

 **IMPORTANT**

This product has been evaluated for use with **copper wire only**.

Wire sizes listed in [Table 6](#) and [Table 7](#) are for copper wiring only. If wire is run in an ambient temperature greater than 40°C, higher temperature wire and/or larger size wire may be necessary. Wire sizes are based on using the specified breakers.

- Recommended wire sizes are based on NFPA National Electrical Code® (NEC®) 70 Table 310.15(B)(16) 75° C ampacity with 40°C ambient correction factors.
- The battery wiring used between the battery and the UPS for standalone installations should be a maximum of 20 meters (65 feet) with a voltage drop of less than 1% of nominal DC voltage at rated battery current.
- Refer to NEC Article 250 and local codes for proper grounding practices.
- Battery voltage is computed at 2 volts per cell as defined by Article 480 of the NEC. Rated battery current is computed at 2 volts per cell.
- The battery cabinet frame is not referenced to the DC circuit.
- Each battery cabinet has its own overcurrent protection device.
- Internal battery strings are to be connected by an authorized Eaton Customer Service Engineer.
- Refer to the appropriate Eaton 93PM UPS installation and operation manual listed in paragraph [1.7 For More Information](#) for UPS cabinet conduit and terminal specifications and locations.
- The term line-up-and-match refers to accessory cabinets that are physically located adjacent to the UPS. The term standalone refers to accessory cabinets that are located separate from the UPS.

For line-up-and-match external power wiring recommendations, including the minimum AWG size of external wiring, see [Table 6](#). For standalone external power wiring requirements, including the minimum AWG size of external wiring, see [Table 7](#), [Table 8](#), or [Table 9](#). Wire sizes listed are for copper wiring only.

**Table 6. Line-Up-and-Match External Power Wiring Recommendations – Eaton 93PM IBC-LW and Eaton 93PM IBC-LHW**

Model	UPS Model	Number of Cabinets	Battery Cabinet to UPS		
			Terminal	Recommended Conductor Size (AWG or kcmil)	Number per Pole
93PM IBC-LW	50 kW	1, 2, 3, or 4	Battery (+)	Factory Supplied	1
	100 kW		Battery (–)	Factory Supplied	1
	150 kW		Ground	#4	one per cabinet
	200 kW				
	400 kW	1, 2, 3, 4, 5, 6, 7, or 8			
93PM IBC-LHW	50 kW	1 or 2	Battery (+)	Factory Supplied	2
	100 kW		Battery (–)	Factory Supplied	2
	150 kW		Ground	#1	one per cabinet
	200 kW				
	400 kW	1, 2, 3, or 4			

**Table 7. Standalone External Power Wiring Recommendation – Eaton 93PM IBC-LW (300A Breaker)**

Model	UPS Model	Number of Cabinets	Battery Cabinet to UPS or External Customer Supplied Tie Point and Breaker or Disconnect			Tie Point and Breaker or Disconnect to UPS		
			Terminal	Recommended Conductor Size for 75°C Copper Wire (AWG or kcmil)	Number per Pole	Recommended Conductor Size (AWG or kcmil)	Number per Pole	
93PM IBC-LW	50 kW 100 kW 150 kW 200 kW	1 or 2	Battery (+)	3/0	2	Not Required		
			Battery (-)	3/0	2	Not Required		
		3 or 4	Battery (+)	3/0	2	3/0	2	
			Battery (-)	3/0	2	3/0	2	
				Ground	#4	one per cabinet	#4	one per cabinet
		<hr/>						
93PM IBC-LW	400-2	1, 2, 3, or 4	Battery (+)	3/0	2	Not Required		
			Battery (-)	3/0	2	Not Required		
	400-2	5, 6, 7, or 8	Battery (+)	3/0	2	3/0	2	
			Battery (-)	3/0	2	3/0	2	
			Ground	#4	one per cabinet	#4	one per cabinet	
	<hr/>							
93PM IBC-LW	400-3 400-4	1, 2, 3, or 4	Battery (+)	300	2	Not Required		
			Battery (-)	300	2	Not Required		
	400-3 400-4	5, 6, 7, or 8	Battery (+)	300	2	300	2	
			Battery (-)	300	2	300	2	
			Ground	#1	one per cabinet	#1	one per cabinet	
	<hr/>							
93PM IBC-LW	400-5	1, 2, 3,	Battery (+)	300	2	500	4	
	400-6	4, 5, 6,	Battery (-)	300	2	500	4	
	400-7	7,						
	400-8	or 8						

**Table 7. Standalone External Power Wiring Recommendation – Eaton 93PM IBC-LW (300A Breaker) (Continued)**

Model	UPS Model	Number of Cabinets	Battery Cabinet to UPS or External Customer Supplied Tie Point and Breaker or Disconnect			Tie Point and Breaker or Disconnect to UPS	
			Terminal	Recommended Conductor Size for 75°C Copper Wire (AWG or kcmil)	Number per Pole	Recommended Conductor Size (AWG or kcmil)	Number per Pole
			Ground	#1	one per cabinet	#1	one per cabinet

**Table 8. Standalone External Power Wiring Recommendations – Eaton 93PM IBC-LW (400A Breaker)**

Model	UPS Model	Number of Cabinets	Battery Cabinet to UPS or External Customer Supplied Tie Point and Breaker or Disconnect			Tie Point and Breaker or Disconnect to UPS			
			Terminal	Recommended Conductor Size for 75°C Copper Wire (AWG or kcmil)	Number per Pole	Recommended Conductor Size (AWG or kcmil)	Number per Pole		
93PM IBC-LW	50 kW 100 kW 150 kW 200 kW	1 or 2	Battery (+)	300	2	Not Required			
			Battery (-)	300	2	Not Required			
		3 or 4	Battery (+)	300	2	300	2		
			Battery (-)	300	2	300	2		
					Ground	#2	one per cabinet	#2	one per cabinet
		93PM IBC-LW	400-2	1, 2, 3, or 4	Battery (+)	300	2	Not Required	
Battery (-)	300				2	Not Required			
400-2	5, 6, 7, or 8		Battery (+)	300	2	300	2		
			Battery (-)	300	2	300	2		
			Ground	#2	one per cabinet	#2	one per cabinet		
93PM IBC-LW	400-3 400-4		1, 2, 3, or 4	Battery (+)	300	2	Not Required		
		Battery (-)		300	2	Not Required			



**Table 8. Standalone External Power Wiring Recommendations – Eaton 93PM IBC-LW (400A Breaker) (Continued)**

Model	UPS Model	Number of Cabinets	Battery Cabinet to UPS or External Customer Supplied Tie Point and Breaker or Disconnect			Tie Point and Breaker or Disconnect to UPS	
			Terminal	Recommended Conductor Size for 75°C Copper Wire (AWG or kcmil)	Number per Pole	Recommended Conductor Size (AWG or kcmil)	Number per Pole
93PM IBC-LW	400-3 400-4	5, 6, 7, or 8	Battery (+)	300	2	300	2
			Battery (-)	300	2	300	2
			Ground	#1	one per cabinet	#1	one per cabinet
	400-5 400-6 400-7 400-8	1, 2, 3, 4, 5, 6, 7, or 8	Battery (+)	300	2	500	4
			Battery (-)	300	2	500	4
			Ground	#1	one per cabinet	#1	one per cabinet

**Table 9. Standalone External Power Wiring Recommendations – Eaton 93PM IBC-LHW (500A Breaker)**

Model	UPS Model	Number of Cabinets	Battery Cabinet to UPS or External Customer Supplied Tie Point and Breaker or Disconnect			Tie Point and Breaker or Disconnect to UPS	
			Terminal	Recommended Conductor Size for 75°C Copper Wire (AWG or kcmil)	Number per Pole	Recommended Conductor Size (AWG or kcmil)	Number per Pole
93PM IBC-LHW	50 kW 100 kW 150 kW 200 kW	1 or 2	Battery (+)	300	2	Not Required	
			Battery (-)	300	2	Not Required	
		3 or 4	Battery (+)	300	2	300	2
			Battery (-)	300	2	300	2
		Ground	#1	one per cabinet	#1	one per cabinet	

93PM IBC-LHW	400-2	1, 2, 3, or 4	Battery (+)	300	2	Not Required	
			Battery (-)	300	2	Not Required	

**Table 9. Standalone External Power Wiring Recommendations – Eaton 93PM IBC-LHW (500A Breaker) (Continued)**

Model	UPS Model	Number of Cabinets	Battery Cabinet to UPS or External Customer Supplied Tie Point and Breaker or Disconnect			Tie Point and Breaker or Disconnect to UPS		
			Terminal	Recommended Conductor Size for 75°C Copper Wire (AWG or kcmil)	Number per Pole	Recommended Conductor Size (AWG or kcmil)	Number per Pole	
93PM IBC-LHW	400-2	5, 6, 7, or 8	Battery (+)	300	2	300	2	
			Battery (-)	300	2	300	2	
			Ground	#1	one per cabinet	#1	one per cabinet	
	400-3 400-4	1, 2, 3, or 4	Battery (+)	300	2	Not Required		
			Battery (-)	300	2	Not Required		
	400-3 400-4	5, 6, 7, or 8	Battery (+)	300	2	300	2	
			Battery (-)	300	2	300	2	
			Ground	#1	one per cabinet	#1	one per cabinet	
	93PM IBC-LHW	400-5 400-6	1, 2, 3, 4, 5, 6,	Battery (+)	300	2	500	4
				7, or 8	Battery (-)	300	2	500
		400-7 400-8	7, or 8		Ground	#1	one per cabinet	#1

The power wiring terminals are pressure terminations, UL and CSA rated at 90°C. See [Table 10](#) for external power cable terminations.

[Figure 14](#) and [Figure 16](#) show the location of the IBC power cable terminals.

**Table 10. External Power Cable Terminations – Eaton 93PM IBC-LW and Eaton 93PM IBC-LHW**

Model	Terminal Function	Terminal	Function	Number and Size of Pressure Termination	Tightening Torque Nm (lb in)	Screw Size and Type
IBC-LW	DC Output	Battery +	Positive	2 - #6-350 kcmil	31 (275)	5/16" Hex
		Battery -	Negative	2 - #6-350 kcmil	31 (275)	5/16" Hex
IBC-LHW	DC Output	Battery +	Positive	2 - #6-350 kcmil	31 (275)	5/16" Hex

**Table 10. External Power Cable Terminations – Eaton 93PM IBC-LW and Eaton 93PM IBC-LHW (Continued)**

Model	Terminal Function	Terminal	Function	Number and Size of Pressure Termination	Tightening Torque Nm (lb in)	Screw Size and Type
		Battery –	Negative	2 - #6-350 kcmil	31 (275)	5/16" Hex
	Customer Ground	Ground	Ground	4 - #14-1/0	5.1 (45) [4AWG-6AWG] 5.6 (50) [3AWG- 1/0]	Slotted

**NOTE** Customer ground, sized in accordance with NEC Table 250.122, can be run in any conduit listed. Refer to the appropriate UPS manual.

External DC input overcurrent protection and disconnect switch for the remote battery location is to be provided by the customer. [Table 11](#) lists the maximum rating for continuous-duty rated circuit breakers satisfying the criteria for both.

**Table 11. Recommended DC Circuit Breaker or Disconnect Ratings (Three or Four IBC-LWs or Two IBC-LHWs)**

Model	UPS Model	Input Rating
Eaton 93PM IBC-LW	50 kW	300A
	100 kW	
	150 kW	
	200 kW	
	400 kW	
Eaton 93PM IBC-LW	50 kW	400A
	100 kW	
	150 kW	
	200 kW	
	400 kW	
Eaton 93PM IBC-LHW	50 kW	500A
	100 kW	
	150 kW	
	200 kW	
	400 kW	

### 3.2.3 IBC Interface Wiring Preparation

Control wiring for features and options should be connected at the customer interface terminal blocks located inside the IBC.



#### **WARNING**

Do not directly connect relay contacts to the mains related circuits. Reinforced insulation to the mains is required.

Read and understand the following notes while planning and performing the installation:

- Use Class 1 wiring methods (as defined by the NEC) for interface wiring from 30V to 600V. The wire should be rated for 600V, 1A minimum. 12 AWG maximum wire size.
- Use Class 2 wiring methods (as defined by the NEC) for interface wiring up to 30V. The wire should be rated for 24V, 1A minimum.

- Because of the battery shunt trip wiring route in the Eaton 93PM UPS cabinet, the wiring from the IBC to the UPS must use wire rated for 600V and Class 1 wiring methods.
- The battery detect signal wiring from the battery cabinet must be connected to a programmed UPS building alarm.
- Battery detect and 48 Vdc shunt trip wiring should be a minimum of 18 AWG.
- Use twisted-pair wires for each input and return or common.
- All interface wiring and conduit is to be supplied by the customer.
- Interface wiring can be installed using the inter-cabinet wiring access pass-through or by routing wiring through conduit between cabinets.
- Install the interface wiring in separate conduit from the power wiring.

### 3.3 Inspecting and Unpacking the IBC

The cabinet is shipped bolted to a metal and wood pallet (see [Figure 7](#)), and covered with outer protective packaging material.



---

**NOTE**

Startup and operational checks must be performed by an authorized Eaton Customer Service Engineer, or the warranty terms specified on the product's resources page become void. See [Chapter 8 Warranty](#) for details. This service is offered as part of the sales contract for the UPS. Contact an Eaton service representative in advance (a minimum two-week notice is required) to reserve a preferred startup date.

---



---

**WARNING**

The IBC is heavy (see [Table 1](#), [Table 2](#), [Table 3](#), and [Table 4](#)). If unpacking and unloading instructions are not closely followed, the cabinet may tip and cause serious injury.

---

1. Carefully inspect the outer packaging for evidence of damage during transit.
- 



---

**CAUTION**

Do not install a damaged cabinet. Report any damage to the carrier and contact an Eaton service representative immediately.

---



---

**NOTE**

For the following step, verify that the forklift or pallet jack is rated to handle the weight of the cabinet (see [Table 1](#), [Table 2](#), [Table 3](#), and [Table 4](#) for cabinet weights).

---

2. Use a forklift or pallet jack to move the packaged cabinet to the installation site, or as close as possible, before unpacking. If possible, move the cabinet using the pallet. Insert the forklift or pallet jack forks between the supports on the bottom of the pallet. See [Figure 6](#) for the IBC-LW cabinet center of gravity measurements.
- 



---

**CAUTION**

Do not tilt the cabinet more than 10° from vertical or the cabinets may tip over.

---

3. Set the pallet on a firm, level surface, allowing a minimum clearance of 3m (10 ft) on each side for removing the cabinet from the pallet.
4. Remove the protective packaging material from the cabinet and recycle in a responsible manner. Retain the parts kit box packed at the top of the cabinet.

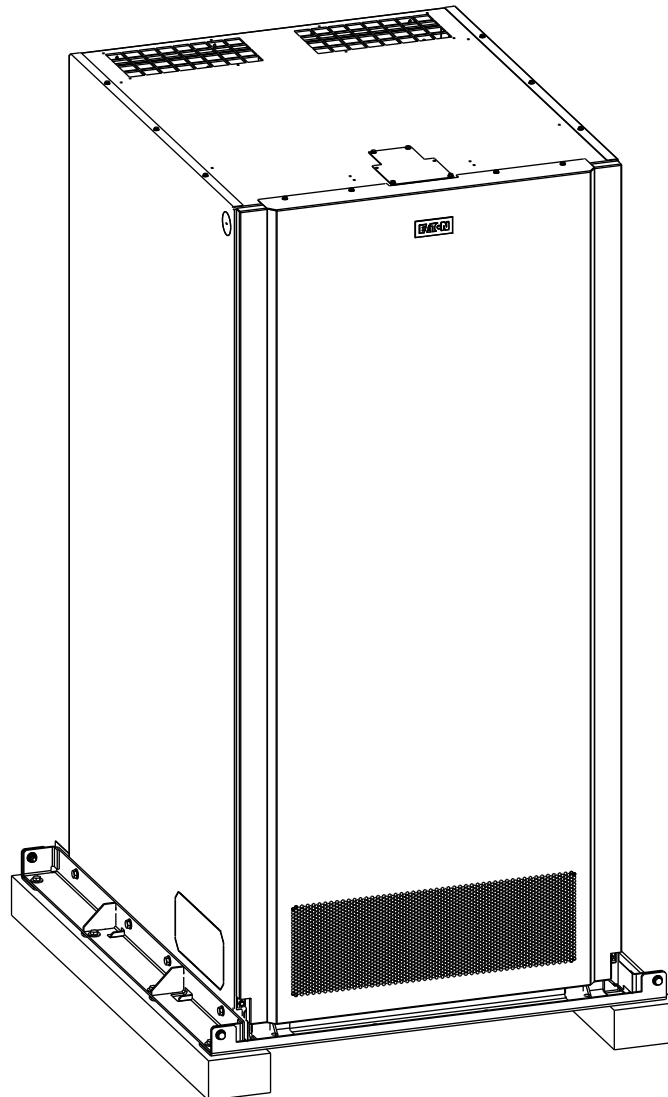
5. Inspect the contents for any evidence of physical damage, and compare each item with the Bill of Lading. If damage has occurred or shortages are evident, contact an Eaton service representative immediately to determine the extent of the damage and its impact on further installation.

**NOTE**

While waiting for installation, protect the unpacked cabinet from moisture, dust, and other harmful contaminants. Failure to store and protect the IBC properly may void the warranty.

---

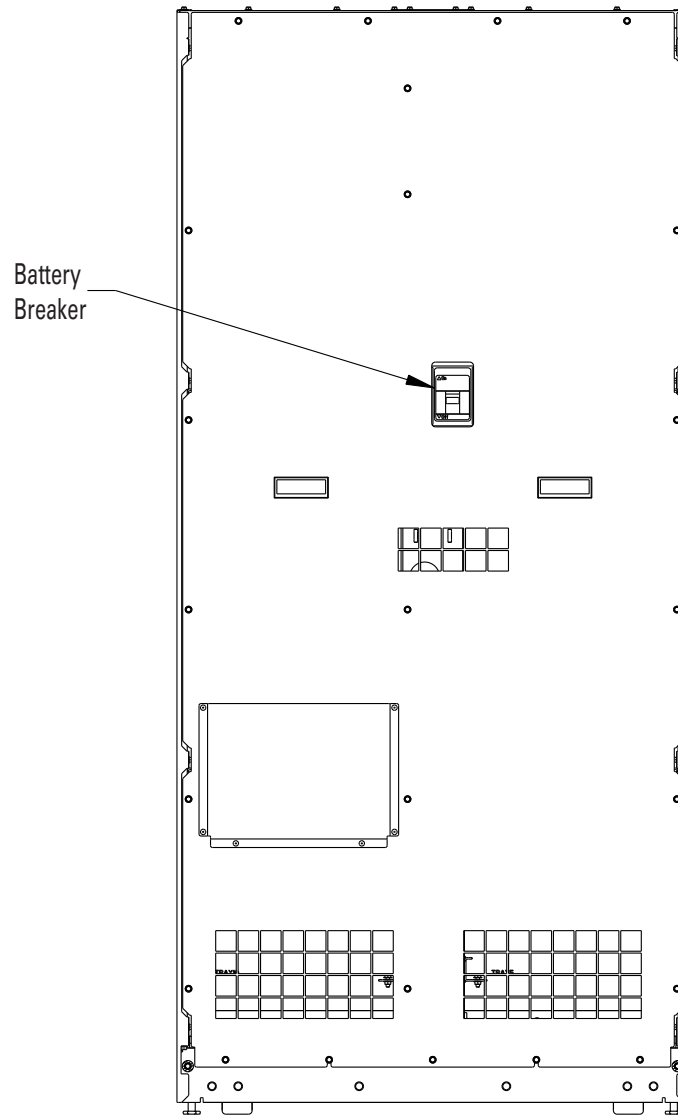
**Figure 7. Eaton 93PM IBC-LW or Eaton 93PM IBC-LHW as Shipped on Pallet**



### 3.4 Battery Breaker Location

[Figure 8](#) shows the location of the battery breaker in the 93PM Universal Integrated Battery Cabinet-Large or 93PM Universal Integrated Battery Cabinet-Large High Rate.

**Figure 8. Eaton 93PM IBC-LW or Eaton 93PM IBC-LHW Battery Breaker Location – Front View with Front Door Removed**



## Chapter 4 Installation

### 4.1 Preliminary Installation Information

---

 **WARNING**

Installation should be performed only by qualified personnel knowledgeable of batteries and the required precautions.

Observe these precautions while installing the Universal Integrated Battery Cabinet (IBC):

- Remove watches, rings, or other metal objects.
- Use tools with insulated handles.
- Wear voltage rated gloves and electrical hazard footwear.
- Do not lay tools or metal parts on top of batteries or battery cabinets.
- Review **Chapter 3 Installation Plan and Unpacking** for cabinet dimensions, equipment weight, wiring and terminal data, and installation notes.

### 4.2 Unloading the IBC Cabinet from the Pallet

---

 **WARNING**

- The IBC is heavy (see [Table 1](#), [Table 2](#), [Table 3](#), and [Table 4](#)). If unpacking and unloading instructions are not closely followed, the cabinet may tip and cause serious injury.
- RISK OF INSTABILITY. Do not remove any internal panels until the cabinet is removed from and lowered from the pallet.
- Do not tilt cabinet more than 10° from vertical.
- Lift the cabinets only with a forklift or pallet jack or damage may occur.
- Ensure forklift is rated to handle the weight of the cabinet.

**Failure to follow these instructions may result in severe injury or death.**

**NOTE**

For the following procedures, verify that the forklift or pallet jack is rated to handle the weight of the cabinet (see [Table 1](#), [Table 2](#), [Table 3](#), and [Table 4](#) for cabinet weight).

The IBC is bolted to a pallet consisting of two metal angle supports and two flat supports secured to two wood supports.

To remove the pallet:

---

 **CAUTION**

Do not use the jacking bolts on a soft surface floor. Use only on a hard surface, such as concrete. If necessary remove pallet on a hard surface and roll cabinet to final installation position.

1. If not already accomplished, use a forklift or pallet jack to move the IBC to the installation area, or as close as possible, before unloading from the pallet. Insert the forklift or pallet jack forks between the supports on the bottom of the pallet (see [Figure 6](#) for the IBC cabinet center of gravity measurements).

2. Remove the front door by loosening the left and right side bottom screws and removing four top screws (see [Figure 9](#)) from the door. Lift the door to disengage the door from the bottom screws. Retain the hardware for later use.
3. Locate the four 1/2" jacking bolts from the parts bag packed inside the front door and install them in the threaded holes in the front and rear supports as shown in [Figure 9](#). Place a floor protector from the parts kit underneath each jacking bolt, and screw the bolts down against them.

The floor protectors protect the floor from being marred by the jacking bolts.

4. Loosen, but do not remove, the skid mounting bolts holding the left, right, front, and rear to the pallet skids (see [Figure 9](#)). **DO NOT** loosen or remove the cabinet mounting bolts or the cabinet support bolts.

---

 **WARNING**

---

RISK OF INSTABILITY. Turning the jacking bolts unevenly may cause the cabinet to become unbalanced. To prevent tipping the cabinet, raise the cabinet no more than 3 mm (1/8") above the floor (just enough to allow the removal of the pallet skids). Failure to follow these instructions can result in serious injury or death.

---

5. Turn each jacking bolt consecutively, two full turns, until the pallet skids clear the floor by approximately 3 mm (1/8").



**NOTE**

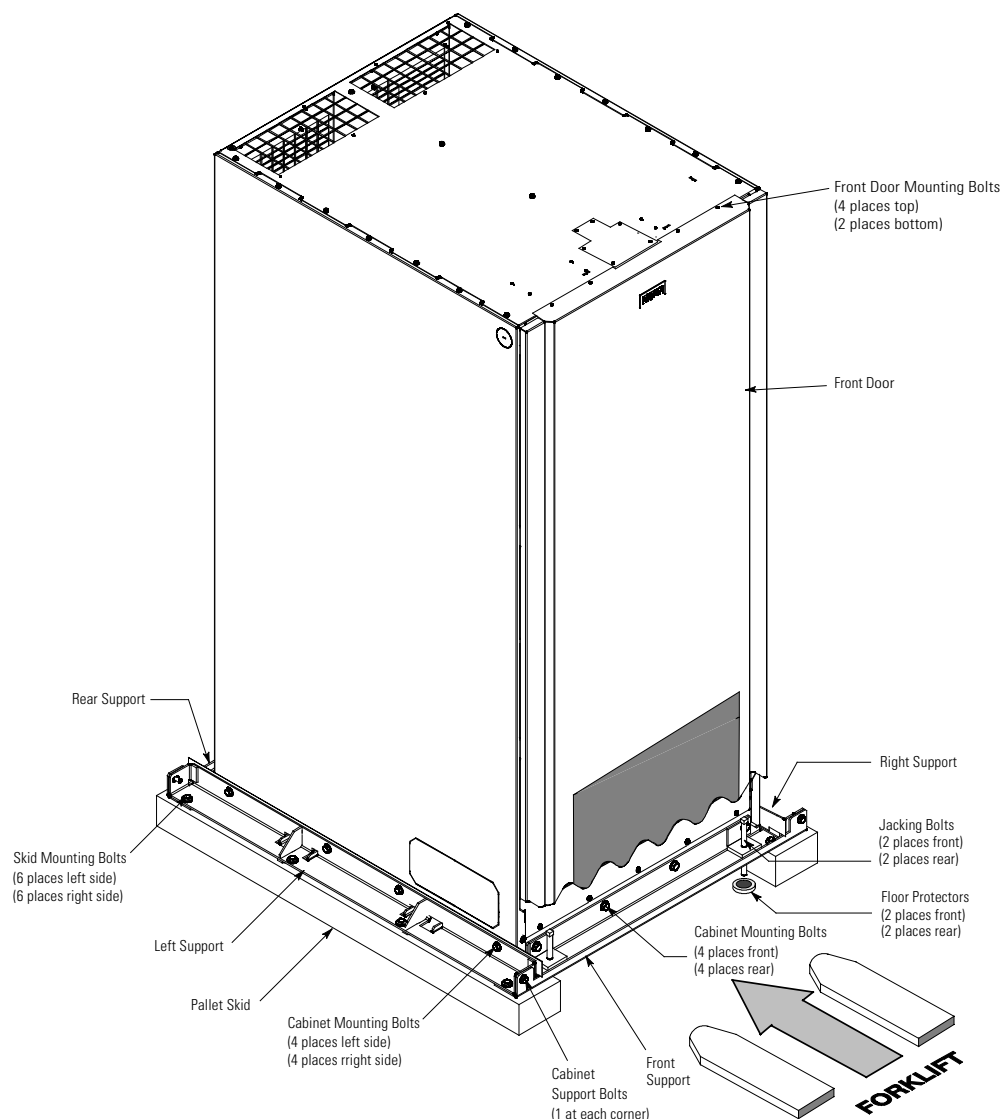
In the following step the center supports will drop away from the cabinet and the pallet skids when the skids are removed.

---

6. Remove the hardware loosened in [Step 4](#).
7. Pull the two pallet skids out from under the left, right, front, rear, and two center supports. Recycle the pallet skids, supports, and hardware in a responsible manner.



**Figure 9. Removing the Pallet Skids and Supports – Eaton 93PM IBC-LW or Eaton 93PM IBC-LHW**



### CAUTION

CABINET MAY FALL. Do not loosen the hardware attaching the front supports to the cabinet base. The cabinet must be lowered by the jacking bolts before the supports can be removed.

8. Carefully and evenly **lower the cabinet by turning each jacking bolt consecutively two full turns (maximum)** until the casters contact the floor and the cabinet is no longer supported by the jacking bolts.
9. After the IBC is resting on the floor, remove the jacking bolts and floor protectors. Recycle them in a responsible manner.
10. Remove the cabinet support bolts fastening the left, right, front, and rear supports together (see [Figure 9](#)).
11. Remove the cabinet mounting bolts holding the left, right, front, and rear supports to the cabinet base.

12. If the leveling feet are not retracted, turn all four leveling feet until they are retracted as far into the cabinet as possible.

**NOTE**

The battery cabinet may be located to either the right or left of the UPS cabinet. The recommended location is to the right of the UPS cabinet. This procedure assumes the battery cabinet is located to the right of the UPS cabinet.

---

13. If line-up-and-match installation, remove the rectangular knockout on the bottom front side of the UPS and the IBC (see [Figure 10](#)).
14. The IBC is shipped set up for rear ventilation with a cover plate installed over the ventilation grill on top of the unit (see [Figure 11](#)). If top ventilation is required, remove the screws securing the plate at the top of the unit and install the plate over the rear ventilation grill (see [Figure 12](#)).

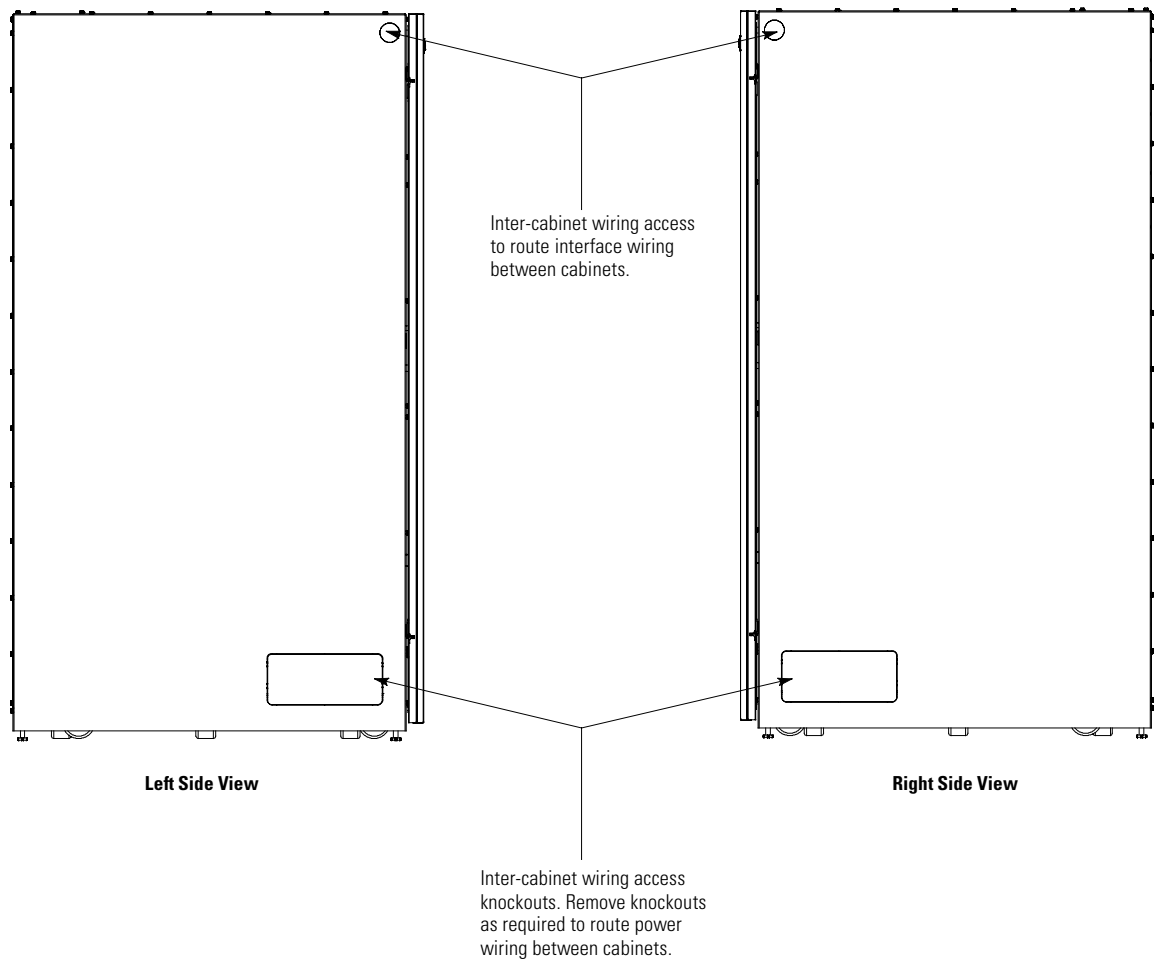
**CAUTION**

To prevent tipping when rolling the cabinet, push the cabinet from the rear whenever possible.

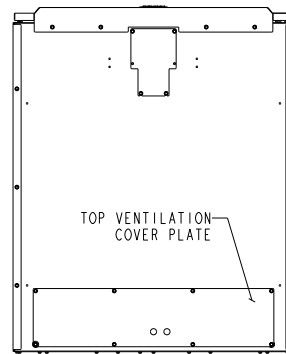
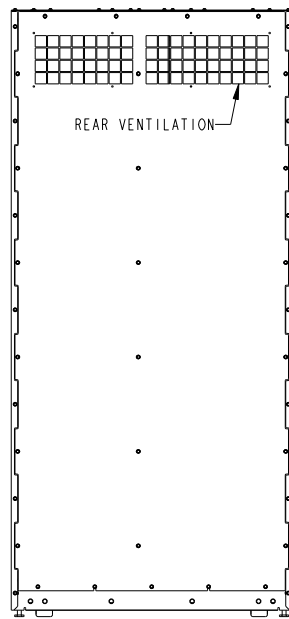
---

15. Roll the IBC to the line-up-and-match installation location on the right side of the UPS cabinet making sure the doors are flush with each other or to the standalone installation location.
16. Lower the cabinet feet and using a level, adjust the cabinet height accordingly until the cabinet is level.
17. If permanently mounting the IBC, proceed to [Step 18](#); otherwise, skip to [Step 21](#).
18. Locate the two floor mounting brackets from the parts kit.
19. Using the retained cabinet mounting bolts, install the floor mounting brackets to the front and rear of the IBC with the angle facing outward.
20. Secure the cabinet to the floor with customer-supplied hardware.
21. If installing more than one IBC, remove the rectangular knockouts on the bottom front sides the IBCs (see [Figure 10](#)) and repeat Steps [Step 1](#) through [Step 20](#); otherwise, proceed to [Step 22](#). Install additional IBCs on the right or left side of the first IBC.
22. Proceed to paragraph [4.3 Installing IBC Power Wiring](#).

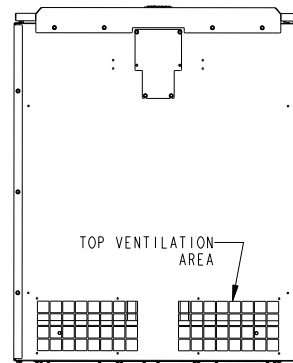
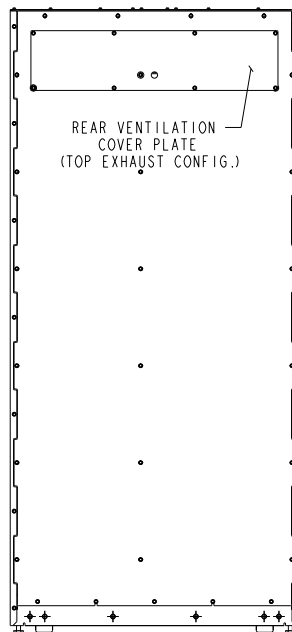
**Figure 10. Line-Up-and-Match Wiring Access Locations**



**Figure 11. Rear Ventilation**



**Figure 12. Top Ventilation**



### 4.3 Installing IBC Power Wiring


IBCs can be installed in a line-up-and-match configuration with the power wiring routed through the bottom of the IBCs and UPS cabinet or in a standalone configuration with the power wiring routed between the IBCs and the UPS cabinet using conduit. Use the appropriate procedure for the type of installation being wired.

#### 4.3.1 Line-Up-and-Match Power Wiring

---

**NOTE 1** All battery cabinets will be directly connected to the UPS and not daisy-chained between each cabinet. All power wiring between the IBCs and the UPS is factory supplied.

**NOTE 2** Up to four IBCs can be installed in a line-up-and-match configuration.

**NOTE 3**  If installing three or four IBCs, longer battery power cables are packed with IBC 3 and IBC 4. Ensure the longer cables are used to wire IBC 3 and IBC 4.

**NOTE 4** See paragraph [3.2.2 IBC Power Wiring Preparation](#), [Table 6](#), and [Table 10](#) for wiring and termination requirements.

**NOTE 5** Refer to the applicable Eaton 93PM UPS Installation and Operation manual, listed in paragraph [1.7 For More Information](#), for UPS cabinet termination requirements.

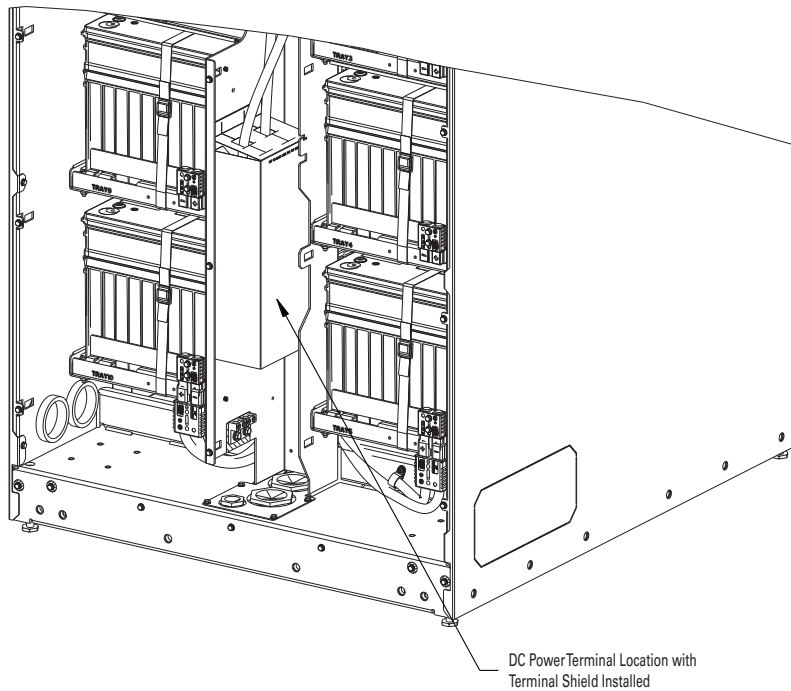
---

Use this procedure to wire line-up-and-match Eaton 93PM Universal Integrated Battery Cabinets to the Eaton 93PM UPS cabinet.

To install wiring to connections:

1. Verify the UPS system is turned off and all power sources are removed. Refer to the applicable Eaton 93PM UPS Installation and Operation manual, listed in paragraph [1.7 For More Information](#), for UPS operating procedures.
2. If not already removed, remove the front door by loosening the left and right side bottom screws and removing four top screws (see [Figure 9](#)) from the door. Lift the door to disengage the door from the bottom screws. Retain the hardware for later use.
3. Remove the screws securing the internal safety shield panel and remove the panel to gain access to the battery power terminals. Retain the hardware for later use.
4. Remove the DC power terminal shield. See [Figure 13](#) for shield location.

**Figure 13. DC Power Terminal Shield Location**



5. Install battery terminal compression lugs to the DC bus bars. Position the open terminal ends pointing down (see [Figure 14](#) and [Figure 16](#)).

---

**NOTE 1** Line-up-and-match positive and negative battery wiring is factory supplied coiled inside the IBC.

**i NOTE 2** Ferrules are installed on the ends of the factory supplied wiring for the 50 kW, 100 kW, and 150 kW Frame UPS models. Ring lugs are installed on the ends of the factory supplied wiring for the 200 kW and 400 kW Frame UPS models. Do not shorten or cut factory supplied wiring.

---

6. Route the battery wiring (positive, negative, and ground) through the bottom side inter-cabinet access pass-through (see [Figure 10](#)) of the UPS cabinet and IBC to the UPS DC Input and IBC DC Output and ground terminal blocks. See [Figure 14](#), [Figure 15](#), and [Figure 16](#) for terminal locations.

---

** WARNING**

---

Verify polarity of connections. Risk of personal injury and damage to equipment from arc flash if connections are reversed.

---

7. Connect the ground wiring to the ground terminal on the IBC. Connect the positive and negative power wiring to the IBC DC (+) and IBC DC (-) output terminals on the IBC.

For a detailed view of the IBC terminal block, see [Figure 16](#).

8. Connect the ground, positive, and negative DC power wiring from the battery cabinet or disconnect to the UPS cabinet ground and battery terminals.

9. Route the other end of the battery wiring (positive, negative, and ground) to the UPS cabinet external battery ground and input terminals. Refer to the applicable Eaton 93PM UPS Installation and Operation manual listed in paragraph [1.7 For More Information](#), for UPS cabinet terminal locations and termination requirements.
10. Connect the ground, positive, and negative power wiring to the UPS cabinet external battery ground and input terminals.

**NOTE**

Route the battery wiring between the UPS and subsequent IBCs through the bottom of the adjacent IBC.

---

11. Reinstall the DC power terminal shield removed in [Step 4](#).
12. If installing more than one IBC, repeat Steps [Step 5](#) through [Step 10](#) for each IBC, and then proceed to paragraph [4.4 Battery Breaker Instantaneous Trip Setting](#); otherwise, skip to paragraph [4.4 Battery Breaker Instantaneous Trip Setting](#).

**NOTE**

Internal battery strings are to be connected by an authorized Eaton Customer Service Engineer at system startup.

---

Figure 14. DC Power Terminal Locations – Eaton 93PM IBC-LW or Eaton 93PM IBC-LHW

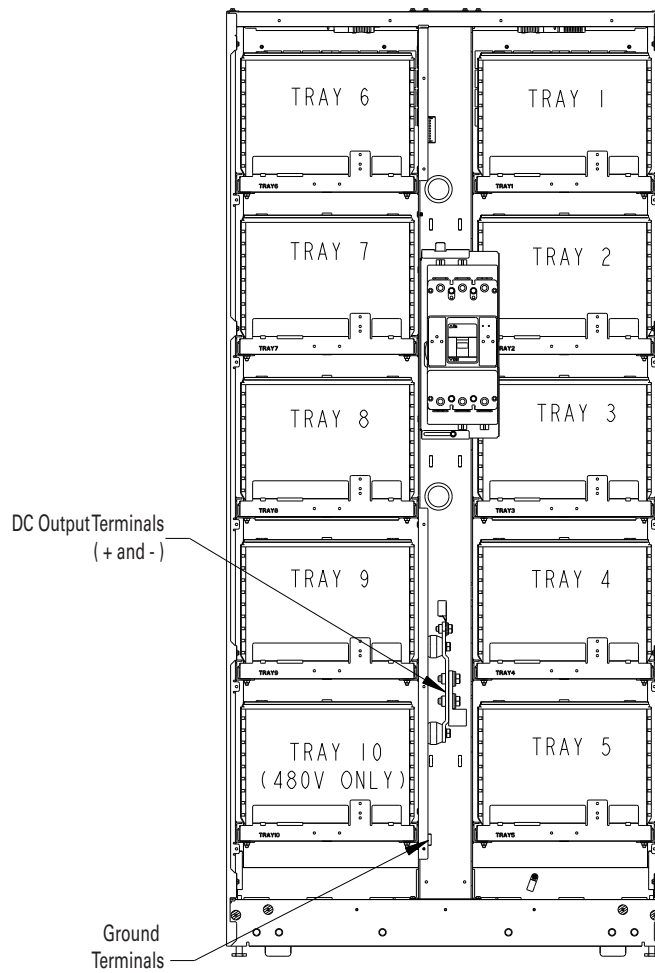
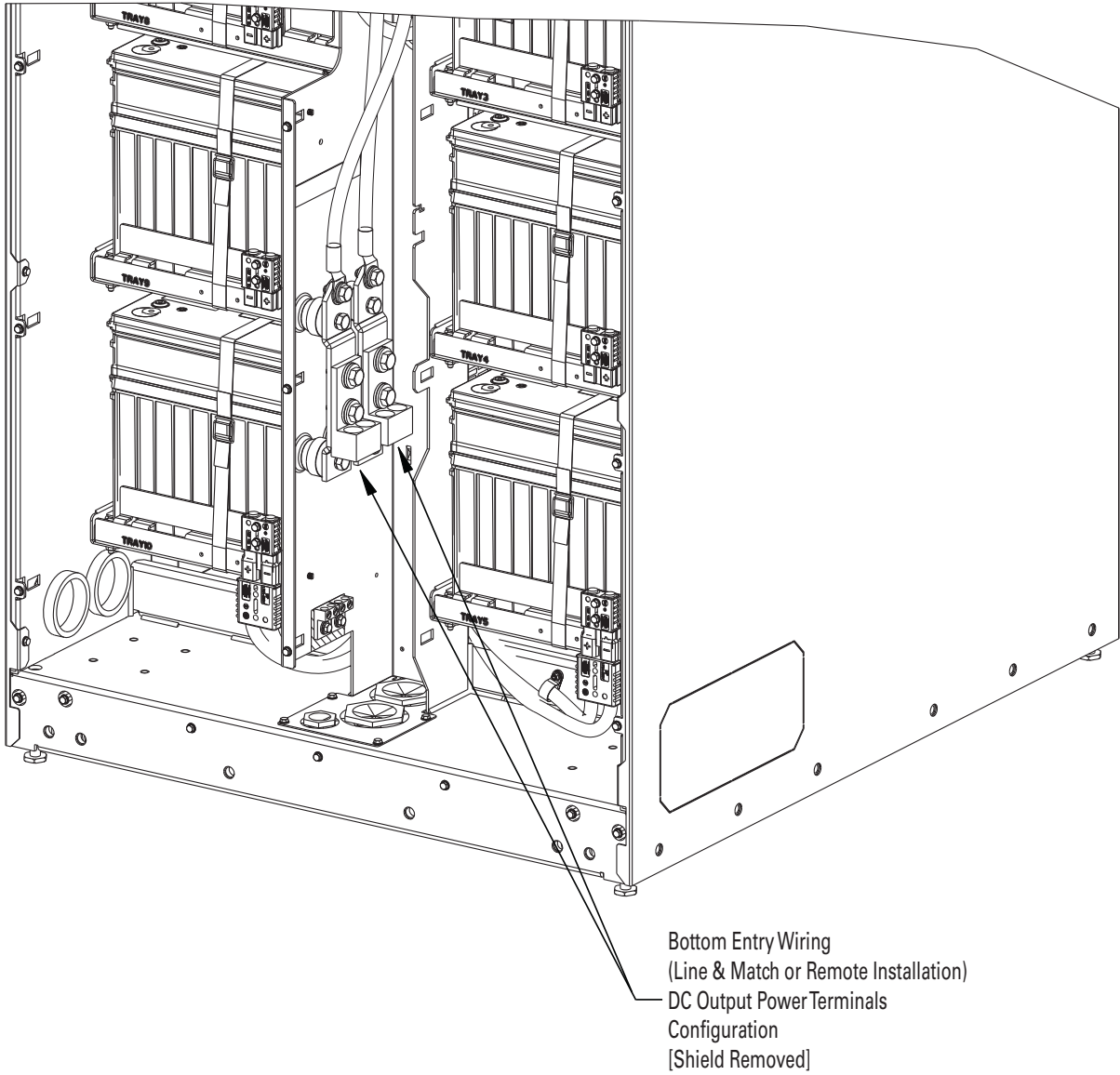
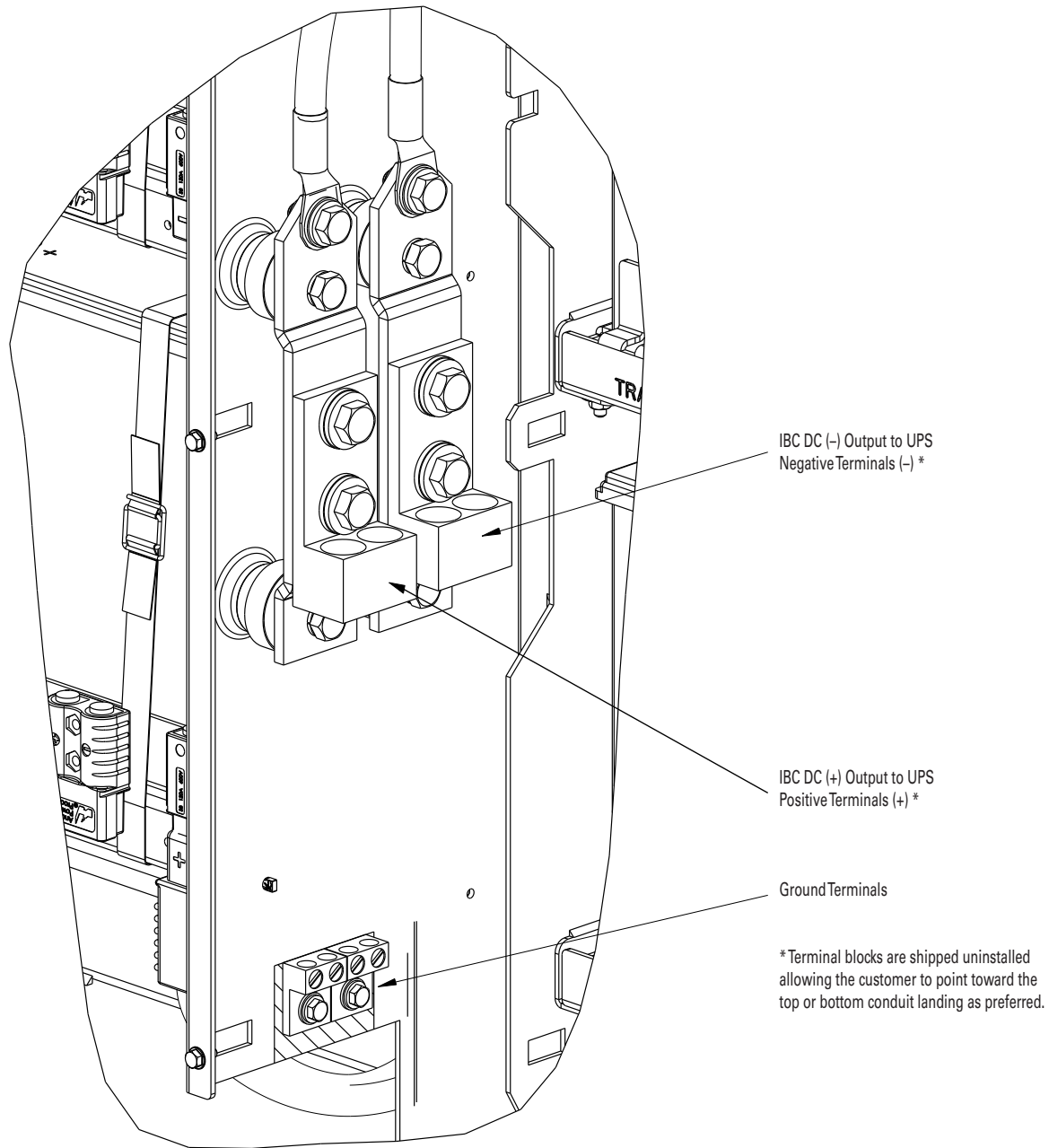




Figure 15. DC Power Terminal — Bottom Wiring Entry Terminal Installation



**Figure 16. DC Power Terminal Detail – Eaton 93PM IBC-LW or Eaton 93PM IBC-LHW**



### 4.3.2 Standalone Power Wiring

**NOTE 1** Standalone IBC installations with three or four IBCs require a customer supplied external tie point and circuit breaker or disconnect between the IBCs and the UPS.

**NOTE 2** Up to four IBCs can be installed in a standalone configuration.



**NOTE 3** See paragraph [3.2.2 IBC Power Wiring Preparation, Table 7](#) through [Table 10](#) for wiring and termination requirements.

**NOTE 4** Refer to the applicable Eaton 93PM UPS Installation and Operation manual, listed in paragraph [1.7 For More Information](#), for the UPS terminal locations and termination requirements.

Use this procedure to wire standalone Eaton 93PM Universal Integrated Battery Cabinets to the Eaton 93PM UPS cabinet.

To install wiring to connections:

1. Verify the UPS system is turned off and all power sources are removed. Refer to the applicable Eaton 93PM UPS Installation and Operation manual, listed in paragraph [1.7 For More Information](#), for UPS operating procedures.
2. If not already removed, remove the front door by loosening the left and right side bottom screws and removing four top screws (see [Figure 9](#)) from the door. Lift the door to disengage the door from the bottom screws. Retain the hardware for later use.
3. Remove the screws securing the internal safety shield panel (dead front) and remove the panel to gain access to the battery power terminals. Retain the hardware for later use.
4. Remove the DC power terminal shield. See [Figure 13](#) for shield location.
5. Install battery terminal compression lugs to the DC bus bars. Position the open terminal ends pointing down for bottom entry wiring and up for top entry wiring (see [Figure 14](#), [Figure 15](#), [Figure 17](#) and [Figure 16](#)).
6. If wiring the IBC using the top entry, proceed to [Step 13](#); otherwise proceed to [Step 7](#).
7. **Bottom Entry Wiring.** Remove the bottom conduit plate (see [Figure 20](#)) from the inside bottom of the IBC. Identify all conduit requirements and mark their location. Drill and punch all conduit holes in the bottom conduit plate prior to mounting on the IBC. Install the conduit plate and install all conduit runs into the plate. Pull the wiring through the conduit into the wiring areas.
8. Route the battery wiring (positive, negative, and ground) from the UPS DC Input terminals or DC disconnect tie point through the bottom of the IBC to the IBC DC Output and ground terminal blocks. See [Figure 14](#), or [Figure 16](#) for terminal locations.
9. Connect the ground wiring to the ground terminal on the IBC. Connect the positive and negative power wiring to the IBC DC (+) and DC (-) output terminals on the IBC.  
For a detailed view of the IBC terminal block, see [Figure 16](#).
10. Connect the ground, positive, and negative DC power wiring from the IBC or disconnect to the UPS cabinet ground and battery terminals.
11. Reinstall the DC power terminal shield removed in [Step 4](#).
12. If installing more than one IBC, repeat Steps [Step 7](#) through [Step 11](#) for each IBC, and then proceed to paragraph [4.4 Battery Breaker Instantaneous Trip Setting](#); otherwise, skip to paragraph [4.4 Battery Breaker Instantaneous Trip Setting](#).
13. **Top Entry Wiring.** Remove the top conduit plate (see [Figure 21](#)) from the top of the IBC. Identify all conduit requirements and mark their location. Drill and punch all conduit holes in the top conduit plate prior

to mounting. Install the conduit plate and install all conduit runs into the plate. Pull the wiring through the conduit into the wiring area.

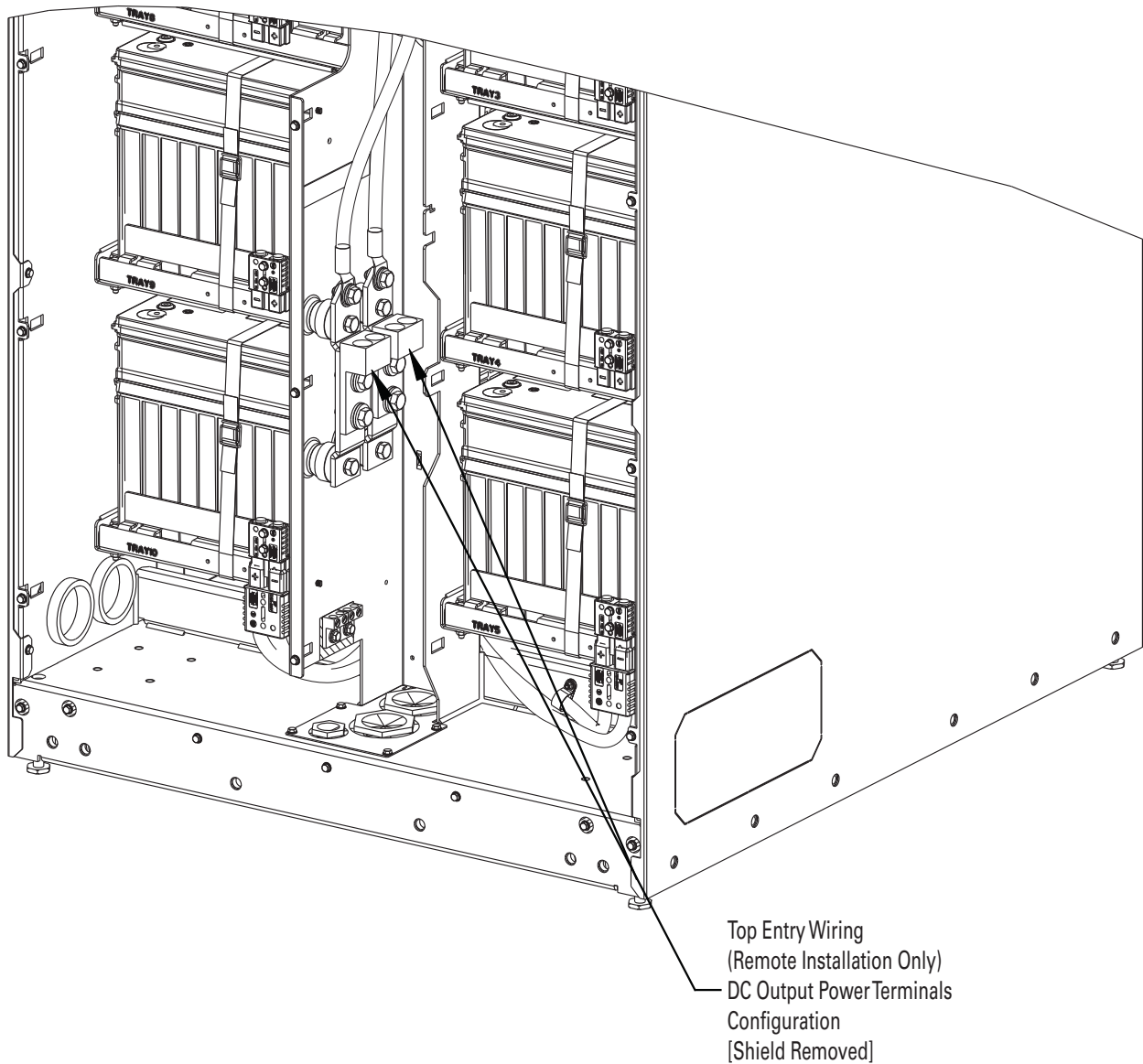
14. During the wiring process you may need to move the Battery Breaker assembly which is mounted on a sliding bracket. To move the assembly, loosen the screw located beneath the breaker and then press the lever on top of the bracket (see [Figure 18](#)) and slide the breaker to the left.

---

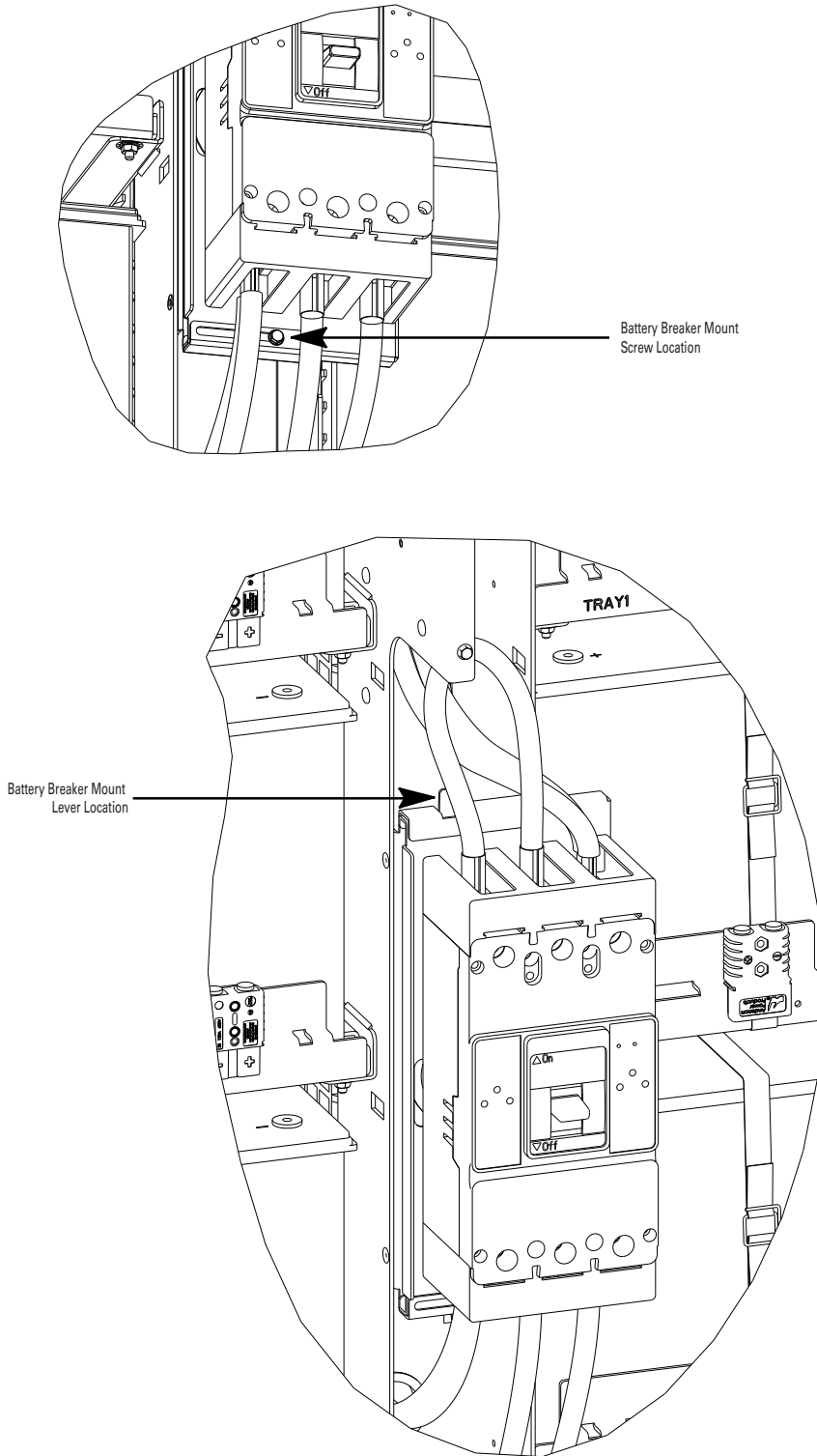
**i NOTE** The breaker assembly must be mounted to the right side in order for the internal safety shield to be installed.

---

**Figure 17. DC Power Terminal – Top Wiring Entry Terminal Installation**

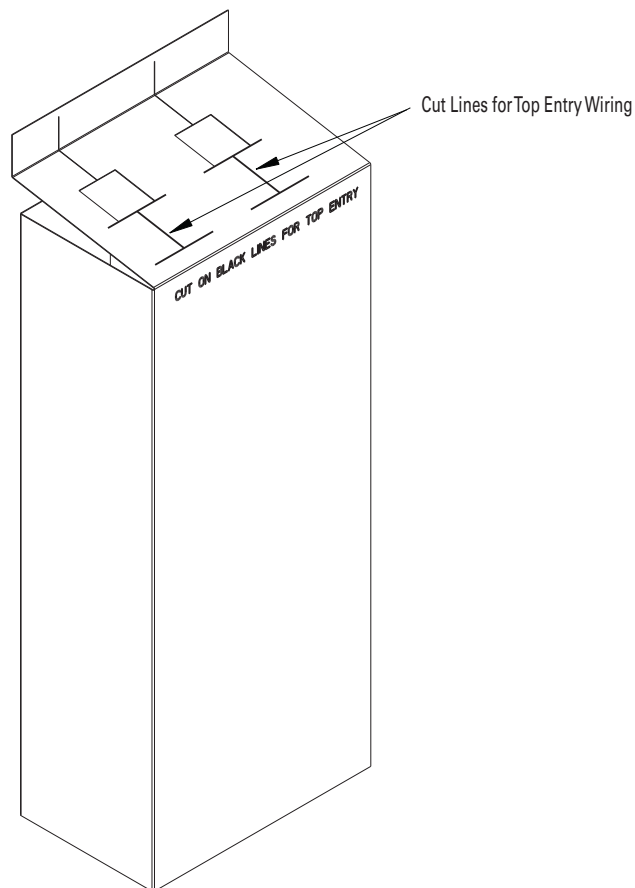


**Figure 18. Battery Breaker Mount Screw Location and Mount Lever Location - Eaton 93PM IBC**



15. Route the battery wiring (positive, negative, and ground) from the UPS DC Input terminals or DC disconnect tie point through the top of the IBC and the IBC inter-cabinet wiring access pass-through running the cables behind the Battery Breaker assembly to the IBC DC Output and ground terminal blocks. See [Figure 14](#), or [Figure 16](#) for terminal locations.
16. Connect the ground wiring to the ground terminal on the IBC. Connect the positive and negative power wiring to the IBC DC (+) and DC (-) output terminals on the IBC.  
For a detailed view of the IBC terminal block, see [Figure 16](#).
17. Connect the ground, positive, and negative DC power wiring from the IBC or disconnect to the UPS cabinet ground and battery terminals.
18. Take the DC power terminal shield and carefully cut along the indicated lines on the top flap. These slots provide the extra space for the top wiring.  
For a detailed view of the DC power terminal shield, see [Figure 19](#).

**Figure 19. DC Power Terminal Shield**



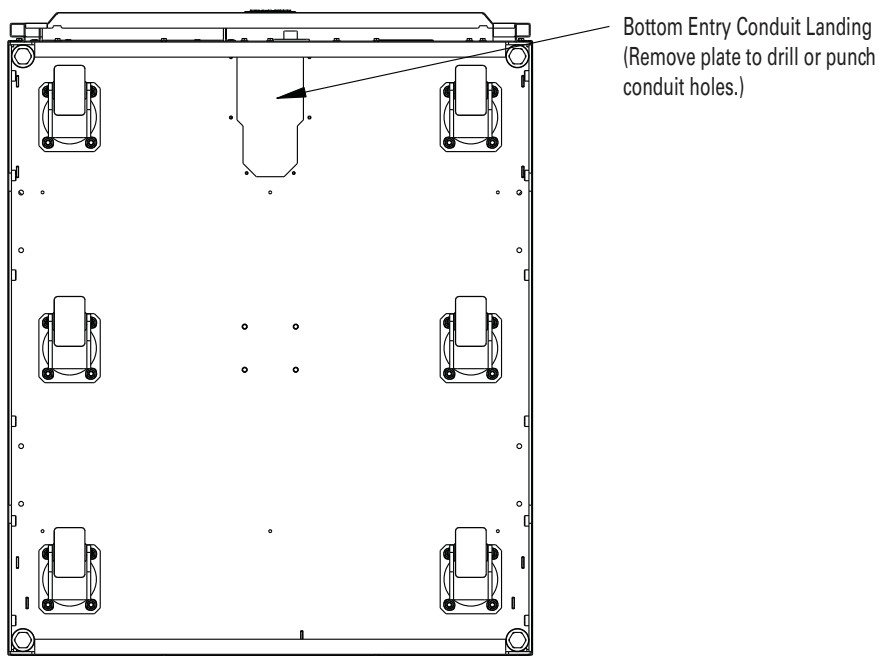
19. Reinstall the DC power terminal shield removed in [Step 4](#).

20. If installing more than one IBC, repeat Steps through [Step 19](#) for each IBC, and then proceed to paragraph [4.4 Battery Breaker Instantaneous Trip Setting](#); otherwise, skip to paragraph [4.4 Battery Breaker Instantaneous Trip Setting](#).

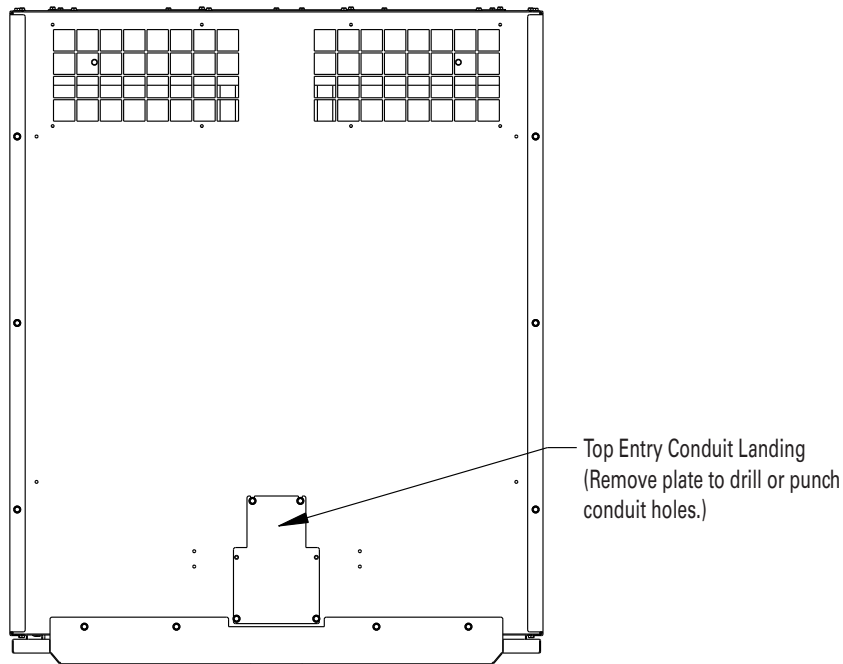
**NOTE**

Internal battery strings are to be connected by an authorized Eaton Customer Service Engineer at system startup.

**Figure 20. IBC Bottom Entry Conduit and Wire Entry Locations**




**Figure 21. IBC Top Entry Conduit and Wire Entry Locations**



#### 4.4 Battery Breaker Instantaneous Trip Setting

---

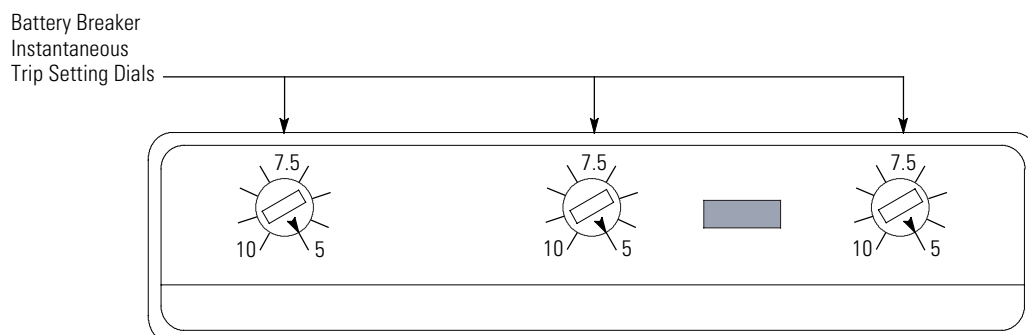
**NOTE**  The specified default instantaneous trip setting provides the maximum protection for the batteries. Failure to adhere to 5x instantaneous trip setting voids the battery warranty.

---

To verify the trip setting:

1. Verify the UPS system is not in reserve mode or operating on battery. Refer to the applicable Eaton 93PM UPS installation and operation manual, listed in paragraph [1.7 For More Information](#), for UPS operating procedures.
2. Verify the battery breaker instantaneous trip setting is set to 5 on all three trip dials (see [Figure 22](#)).
3. If dials are not set to 5, set each to 5.
4. Proceed to paragraph [4.5 Installing IBC Interface Wiring](#).



**Figure 22. Battery Breaker Instantaneous Trip Setting Dials**

## 4.5 Installing IBC Interface Wiring

IBCs can be installed in a line-up-and-match configuration with the interface wiring routed through the IBCs and UPS cabinet or in a standalone configuration with the interface wiring routed between the IBCs and the UPS cabinet using conduit.

### 4.5.1 Installing Battery Detect Interface Connections

**NOTE 1** Disconnect terminal block plug from terminal block to wire plug.

**NOTE 2** If the inter-cabinet wiring access pass-through is not used to install the battery detect interface wiring connections, conduit must be installed between the battery cabinet and the UPS cabinet.



**NOTE 3** See paragraph [3.2.3 IBC Interface Wiring Preparation](#), [Table 12](#), and [Figure 24](#) for wiring and termination requirements.

**NOTE 4** Refer to the applicable Eaton 93PM UPS Installation and Operation manual listed in paragraph [1.7 For More Information](#), for UPS cabinet terminal locations.

To install wiring:

1. If wiring the IBC battery detect interface terminals using line-up-and-match wiring using the inter-cabinet wiring access pass-through (see [Figure 10](#)) proceed to [Step 2](#); if wiring the IBC battery detect interface terminals using the top entry access, proceed to [Step 4](#); if wiring the IBC battery detect interface terminals using the bottom entry access, proceed to [Step 7](#).



**NOTE** In multiple IBC installations, route the battery interface wiring between IBCs through the top of the adjacent IBC using the top inter-cabinet access pass-through (see [Figure 10](#)).

2. **Line-Up-and-Match Wiring.** Route the battery detect interface wiring from the UPS battery detect (building alarm) interface terminals through the top inter-cabinet access pass-through (see [Figure 10](#)) of the UPS cabinet and IBC to the IBC battery interface terminal block TB2. See [Figure 23](#) for terminal locations.
3. Proceed to [Step 9](#).

4. **Top Entry Wiring.** Remove the top conduit plate (see [Figure 21](#)) from the top of the IBC. Identify all conduit requirements and mark their location. Drill and punch all conduit holes in the top conduit plate prior to mounting on the IBC. Install the conduit plate and install all conduit runs into the plate. Pull the wiring through the conduit into the wiring area.

**NOTE**

In multiple IBC installations, route the battery interface wiring between IBCs through the top of the adjacent IBC using the top inter-cabinet access pass-through (see [Figure 10](#)).

---

5. Route the battery detect interface wiring from the UPS battery detect (building alarm) interface terminals through the top of the IBC and the top IBC inter-cabinet wiring access pass-through (see [Figure 10](#)) to the IBC battery interface terminal block TB2. See [Figure 23](#) for terminal locations.
6. Proceed to [Step 9](#).
7. **Bottom Entry Wiring.** Remove the bottom conduit plate (see [Figure 20](#)) from the inside bottom of the IBC. Identify all conduit requirements and mark their location. Drill and punch all conduit holes in the bottom conduit plate prior to mounting on the IBC. Install the conduit plate and install all conduit runs into the plate. Pull the wiring through the conduit into the wiring areas.

**NOTE 1**

In multiple IBC installations, route the battery interface wiring between IBCs through the top of the adjacent IBC using the top inter-cabinet access pass-through (see [Figure 10](#)).

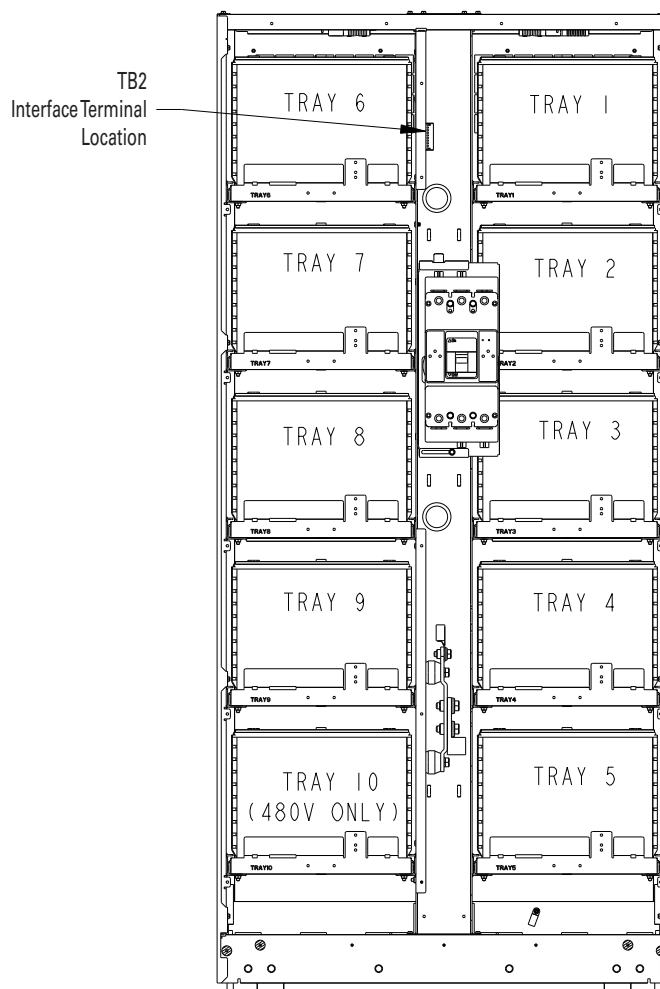
**NOTE 2**

In the following step, leave slack in the interface cables to allow breaker tray movement.

---

8. Route the battery detect interface wiring from the UPS battery detect (building alarm) interface terminals through the bottom of the IBC up the left flange of the center channel to the IBC battery interface terminal block TB2. See [Figure 23](#) for terminal locations.
9. Connect the battery detect interface wiring to the IBC battery detect interface terminals. See [Table 13](#) for termination requirements.  
For a detailed view of the IBC terminal block, see [Figure 25](#).
10. Connect the battery detect interface wiring to the UPS battery detect interface (building alarm) terminals. Refer to the applicable Eaton 93PM UPS Installation and Operation manual listed in paragraph [1.7 For More Information](#), for UPS cabinet termination requirements.
11. Proceed to paragraph [4.5.2 Installing Battery Shunt Trip Interface Connections](#).

**Figure 23. Interface Terminal Locations – Eaton 93PM IBC-LW or Eaton 93PM IBC-LHW**



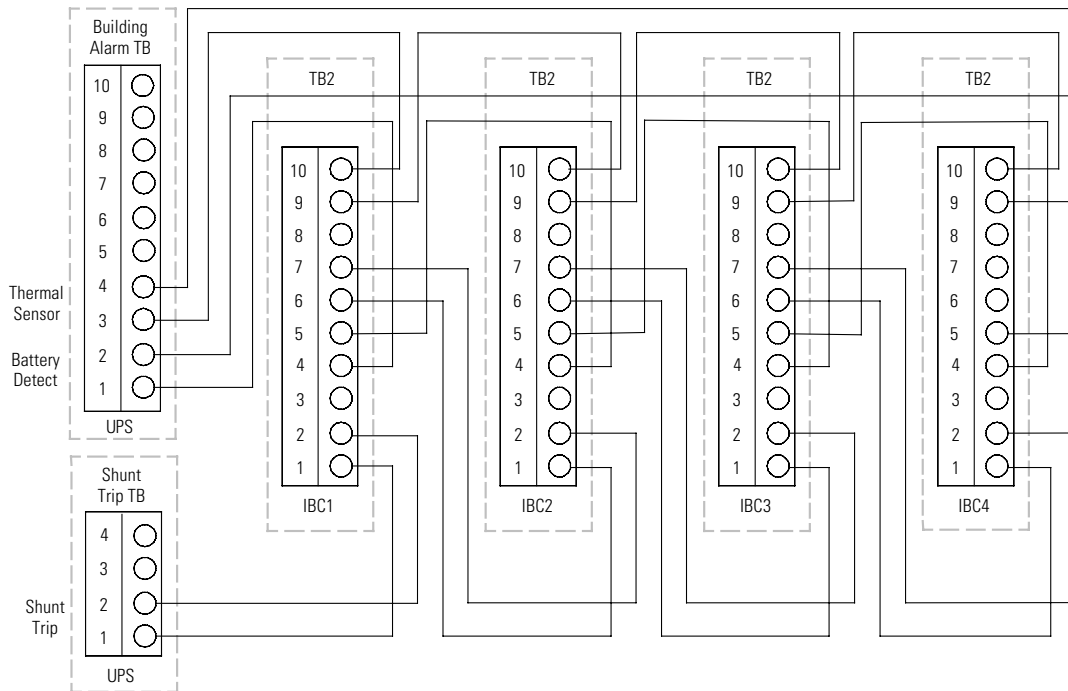
**Table 12. Eaton 93PM IBC-LW or Eaton 93PM IBC-LHW – TB2 Interface Connections**

Terminal TB2	Name	Description
10	Thermal Sensor (Optional)	Contacts used to signal a battery temperature out of specification and to turn off the battery charger to prevent thermal runaway.
9	Thermal Sensor (Optional)	
8	Not Used	
7	To Next IBC TB2-2	Contacts used to open battery breaker or disconnect on second, third and fourth IBCs.
6	To Next IBC TB2-1	
5	Battery Detect	Contacts used to indicate whether UPS battery breaker is open or closed.
4	Battery Detect Common (UPS)	
3	Not Used	

**Table 12. Eaton 93PM IBC-LW or Eaton 93PM IBC-LHW – TB2 Interface Connections (Continued)**

Terminal TB2	Name	Description
2	Battery Shunt Trip - (UPS)	Contacts used to open battery breaker or disconnect.
1	Battery Shunt Trip + (UPS)	

**Figure 24. Shunt Trip and Battery Detect Wiring**



**NOTE 1** IBC1 is closest to the UPS.

**NOTE 2** The IBC shunt trip is wired in parallel. The IBC battery detect is wired in series.

**NOTE 3** TB2 is located at the top of the IBC.

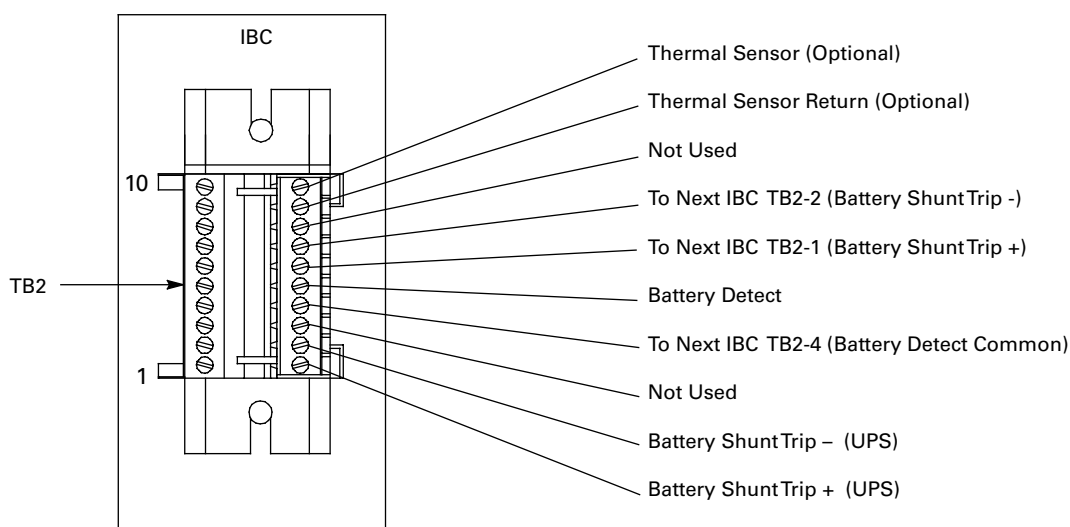
**NOTE 4** If less than four IBCs are installed, the last IBC TB2-5 connection returns to UPS Building Alarm terminal.

**NOTE 5** The Thermal Sensor is optional.

**Table 13. Eaton 93PM IBC-LW or Eaton 93PM IBC-LHW – TB2 Interface Wiring Terminal Block Terminations**

Terminal Function	Size of Pressure Termination	Tightening Torque Nm (lb in)	Type Screw	Comments
Shunt Trip	#26-#16	0.4 (3.5) - 0.8 (7.1)	Slotted	Use twisted-pair wires for each input and return or common. Strip wire insulation back 10 millimeters to wire terminal blocks. Use wire rated for 600V and Class 1 wiring methods.
Battery Detect	#26-#16	0.4 (3.5) - 0.8 (7.1)	Slotted	Use twisted-pair wires for each input and return or common. Strip wire insulation back 10 millimeters to wire terminal blocks.
Thermal Sensor	#26-#16	0.4 (3.5) - 0.8 (7.1)	Slotted	Use twisted-pair wires for each input and return or common. Strip wire insulation back 10 millimeters to wire terminal blocks.

**Figure 25. Interface Terminal Detail – Eaton 93PM IBC-LW or Eaton 93PM IBC-LHW**



**NOTE 1** TB2 is located at the top of the IBC.

**NOTE 2** TB2 connector pin 1 located at the bottom of the terminal block.


**NOTE 3** The Thermal Sensor is optional.

#### 4.5.2 Installing Battery Shunt Trip Interface Connections

---

**NOTE 1** Disconnect terminal block plug from terminal block to wire plug.

**NOTE 2** Because of the battery shunt trip wiring route in the Eaton 93PM UPS cabinet, the wiring from the IBC shunt trip terminals to the UPS must use wire rated for 600V and Class 1 wiring methods.

 **NOTE 3** If the inter-cabinet wiring access pass-through is not used to install the battery shunt trip interface wiring connections, conduit must be installed between the battery cabinet and the UPS cabinet.

**NOTE 4** See paragraph [3.2.3 IBC Interface Wiring Preparation, Table 12](#), and [Figure 24](#) for wiring and termination requirements.


**NOTE 5** Refer to the applicable Eaton 93PM UPS Installation and Operation manual listed in paragraph [1.7 For More Information](#), for UPS cabinet terminal locations.

---

To install wiring:

1. If wiring the IBC shunt trip interface terminals using the line-up-and-match inter-cabinet wiring access pass-through (see [Figure 10](#)) proceed to [Step 2](#); if wiring the IBC shunt trip interface terminals using the top entry access, proceed to [Step 4](#); if wiring the IBC shunt trip interface terminals using the bottom entry access, proceed to [Step 7](#).


---

 **NOTE** In multiple IBC installations, route the battery interface wiring between IBCs through the top of the adjacent IBC using the top inter-cabinet access pass-through (see [Figure 10](#)).

---

2. **Line-Up-and-Match Wiring.** Route the battery shunt trip interface wiring from the UPS battery shunt trip interface terminals through the bottom inter-cabinet access pass-through (see [Figure 10](#)) of the UPS cabinet and IBC to the IBC battery interface terminal block TB2. See [Figure 23](#) for terminal locations.
3. Proceed to [Step 9](#).
4. **Top Entry Wiring.** Remove the top conduit plate (see [Figure 21](#)) from the top of the IBC. Identify all conduit requirements and mark their location. Drill and punch all conduit holes in the top conduit plate prior to mounting on the IBC. Install the conduit plate and install all conduit runs into the plate. Pull the wiring through the conduit into the wiring area.


---

 **NOTE** In multiple IBC installations, route the battery interface wiring between IBCs through the top of the adjacent IBC using the top inter-cabinet access pass-through (see [Figure 10](#)).

---

5. Route the battery shunt trip interface wiring from the UPS battery shunt trip interface terminals through the top of the IBC and the top IBC inter-cabinet wiring access pass-through (see [Figure 10](#)) to the IBC battery interface terminal block TB2. See [Figure 23](#) for terminal locations.
6. Proceed to [Step 9](#).
7. **Bottom Entry Wiring.** Remove the bottom conduit plate (see [Figure 20](#)) from the inside bottom of the IBC. Identify all conduit requirements and mark their location. Drill and punch all conduit holes in the bottom conduit plate prior to mounting on the IBC. Install the conduit plate and install all conduit runs into the plate. Pull the wiring through the conduit into the wiring areas.

---

 **NOTE 1** In multiple IBC installations, route the battery interface wiring between IBCs through the top of the adjacent IBC using the top inter-cabinet access pass-through (see [Figure 10](#)).

**NOTE 2** In the following step, leave slack in the interface cables to allow breaker tray movement.

---

8. Route the battery shunt trip interface wiring from the UPS battery shunt trip interface terminals through the bottom of the IBC to the IBC battery interface terminal block TB2. See [Figure 23](#) for terminal locations.
9. Connect the battery shunt trip interface wiring to the IBC battery shunt trip interface terminals. See [Table 13](#) for termination requirements.

For a detailed view of the IBC terminal block, see [Figure 25](#).

10. Connect the battery shunt trip interface wiring to the UPS battery shunt trip interface terminals. Refer to the applicable Eaton 93PM UPS Installation and Operation manual listed in paragraph [1.7 For More Information](#), for UPS cabinet termination requirements.

**NOTE**

In the following step, if the safety shield cannot be reinstalled because of misalignment, use the leveling feet to realign the cabinet.

---

11. Reinstall the internal safety shield panel removed in [Step 3](#) of paragraph [4.3.1 Line-Up-and-Match Power Wiring](#).
12. Install the front door (previously removed) by carefully lowering the door onto the bottom screws. Secure the top of the door with the four retained screws and tighten the bottom screws (see [Figure 9](#)).
13. Once the battery cabinets are installed and wired, return to the applicable Eaton 93PM UPS Installation and Operation manual, listed in paragraph [1.7 For More Information](#), to complete the UPS wiring.

### 4.5.3 Installing Thermal Sensor Interface Connections

---

**NOTE 1** The UPS thermal sensor signal uses an UPS building alarm input to indicate a thermal trip condition and to turn off the battery charger.

**NOTE 2** Any pair of unused building alarm terminals may be used for the thermal sensor connections.

**NOTE 3** Program the thermal sensor building alarm to read battery thermal trip and for normally closed contacts.



**NOTE 4** Disconnect terminal block plug from terminal block to wire plug.

**NOTE 5** If the inter-cabinet wiring access pass-through is not used to install the thermal sensor interface wiring connections, conduit must be installed between the battery cabinet and the UPS cabinet.

**NOTE 6** See paragraph [3.2.3 IBC Interface Wiring Preparation](#), [Table 12](#), and [Figure 24](#) for wiring and termination requirements.

**NOTE 7** Refer to the applicable Eaton 93PM UPS Installation and Operation manual listed in paragraph [1.7 For More Information](#), for UPS cabinet terminal locations.

---

To install wiring:

1. If not already removed, remove the front door by loosening the left and right side bottom screws and removing four top screws (see [Figure 9](#)) from the door. Lift the door to disengage the door from the bottom screws. Retain the hardware for later use.
2. If not already removed, remove the screws securing the internal safety shield panel (dead front) and remove the panel to gain access to the battery power terminals. Retain the hardware for later use.
3. If wiring the IBC thermal sensor interface terminals using line-up-and-match wiring using the inter-cabinet wiring access pass-through (see [Figure 10](#)) proceed to [Step 4](#); if wiring the IBC thermal sensor interface terminals using the top entry access, proceed to [Step 6](#); if wiring the IBC thermal sensor interface terminals using the bottom entry access, proceed to [Step 9](#).

---

**i NOTE** In multiple IBC installations, route the battery interface wiring between IBCs through the top of the adjacent IBC using the top inter-cabinet access pass-through (see [Figure 10](#)).

---

4. **Line-Up-and-Match Wiring.** Route the thermal sensor interface wiring from the UPS thermal sensor (building alarm) interface terminals through the top inter-cabinet access pass-through (see [Figure 10](#)) of the UPS cabinet and IBC to the IBC battery interface terminal block TB2. See [Figure 23](#) for terminal locations.
5. Proceed to [Step 11](#).
6. **Top Entry Wiring.** Remove the top conduit plate (see [Figure 21](#)) from the top of the IBC. Identify all conduit requirements and mark their location. Drill and punch all conduit holes in the top conduit plate prior to mounting on the IBC. Install the conduit plate and install all conduit runs into the plate. Pull the wiring through the conduit into the wiring area.

---

**i NOTE** In multiple IBC installations, route the battery interface wiring between IBCs through the top of the adjacent IBC using the top inter-cabinet access pass-through (see [Figure 10](#)).

---

7. Route the thermal sensor interface wiring from the UPS thermal sensor (building alarm) interface terminals through the top of the IBC and the top IBC inter-cabinet wiring access pass-through (see [Figure 10](#)) to the IBC battery interface terminal block TB2. See [Figure 23](#) for terminal locations.
8. Proceed to [Step 11](#).
9. **Bottom Entry Wiring.** Remove the bottom conduit plate (see [Figure 20](#)) from the inside bottom of the IBC. Identify all conduit requirements and mark their location. Drill and punch all conduit holes in the bottom conduit plate prior to mounting on the IBC. Install the conduit plate and install all conduit runs into the plate. Pull the wiring through the conduit into the wiring areas.

---

**i NOTE 1** In multiple IBC installations, route the battery interface wiring between IBCs through the top of the adjacent IBC using the top inter-cabinet access pass-through (see [Figure 10](#)).

**NOTE 2** In the following step, leave slack in the interface cables to allow breaker tray movement.


---

10. Route the thermal sensor interface wiring from the UPS thermal sensor (building alarm) interface terminals through the bottom of the IBC to the IBC battery interface terminal block TB2. See [Figure 23](#) for terminal locations.
11. Connect the thermal sensor interface wiring to the IBC thermal sensor interface terminals. See [Table 13](#) for termination requirements.  
For a detailed view of the IBC terminal block, see [Figure 25](#).
12. Connect the thermal sensor interface wiring to the UPS thermal sensor interface (building alarm) terminals. Refer to the applicable Eaton 93PM UPS Installation and Operation manual listed in paragraph [1.7 For More Information](#), for UPS cabinet termination requirements
13. Reinstall the internal safety shield panel removed in [Step 3](#) of paragraph [4.3.1 Line-Up-and-Match Power Wiring](#).
14. Install the front door (previously removed) by carefully lowering the door onto the bottom screws. Secure the top of the door with the four retained screws and tighten the bottom screws.(see [Figure 9](#)).
15. Once the battery cabinets are installed and wired, return to the applicable Eaton 93PM UPS Installation and Operation manual, listed in paragraph [1.7 For More Information](#), to complete the UPS wiring.



## 4.6 Initial Startup

---

**NOTE**  Startup and operational checks must be performed by an authorized Eaton Customer Service Engineer, or the warranty terms specified on the product's resources page become void. See [Chapter 8 Warranty](#) for details. This service is offered as part of the sales contract for the UPS. Contact an Eaton service representative in advance (a minimum two-week notice is required) to reserve a preferred startup date.


---

## 4.7 Completing the Installation Checklist

The final step in installing the IBC is completing the following Installation Checklist. This checklist ensures that you have completely installed all hardware, cables, and other equipment. Complete all items listed on the checklist to ensure a smooth installation. Make a copy of the Installation Checklist before filling it out, and retain the original.

After the installation is complete, an Eaton Customer Service Engineer must verify the operation of the UPS system and commission it to support the critical load. The service representative cannot perform any installation tasks other than verifying software and operating setup parameters. Service personnel may request a copy of the completed Installation Checklist to verify all applicable equipment installations have been completed.

---

**NOTE**  The Installation Checklist MUST be completed prior to starting the UPS system for the first time.

---

## 4.8 Installation Checklist

- All IBCs are the same model and rating.
- All packing materials and restraints have been removed from each cabinet.
- The IBCs are installed on a level floor suitable for computer or electronic equipment.
- The IBCs are placed in their installed location.
- All conduits and cables are properly routed between the IBCs and the UPS.
- All power cables are properly sized and terminated.
- A ground conductor is properly installed.
- Battery cables are terminated on the positive and negative terminals in the UPS cabinet.
- Battery Shunt Trip and Battery Detect signal wiring is connected from the battery breaker to the UPS.
- Thermal Sensor signal wiring is connected from the battery cabinet to the UPS.
- All internal safety shields are installed.
- Air conditioning equipment is installed and operating correctly.
- The area around the UPS system is clean and dust-free.
- Adequate workspace exists around the IBC and other cabinets.
- Adequate lighting is provided around all IBC and UPS equipment.
- A 120 Vac service outlet is located within 7.5 meters (25 feet) of the IBC and UPS equipment.
- Startup and operational checks are performed by an authorized Eaton Customer Service Engineer.
- Visit [www.eaton.com/pg/register](http://www.eaton.com/pg/register) to register your new Eaton UPS / Eaton UPS Accessory.



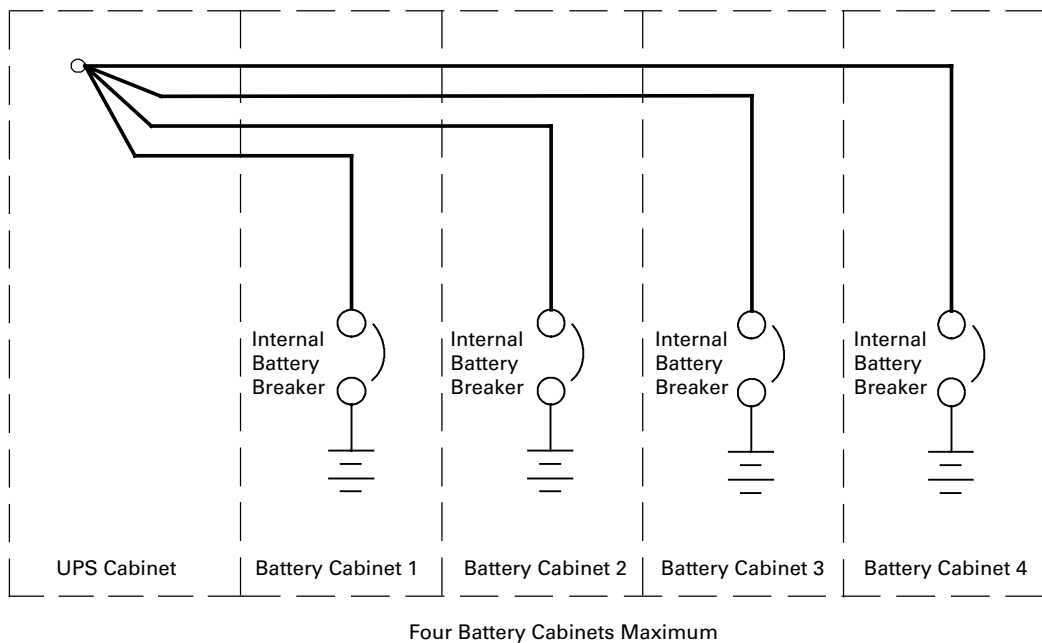
## Chapter 5 Onelines and Schematics

### 5.1 Power Onelines

Figure 26 through Figure 28 show the UPS and Eaton 93PM Universal Integrated Battery Cabinet-Large (IBC-LW) intercabinet power connection onelines. Figure 29 through Figure 31 show the UPS and Eaton 93PM Universal Integrated Battery Cabinet-Large High Rate (IBC-LHW) intercabinet power connection onelines.

See paragraph 3.2.2 *IBC Power Wiring Preparation* for wiring installation notes and Table 6 through Table 9 for wiring recommendations.

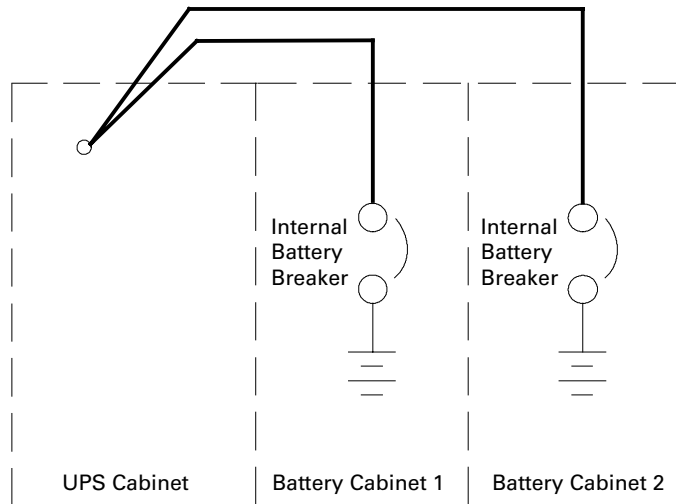
**Figure 26. Eaton 93PM IBC-LW Line-Up-and-Match Power Oneline**



**NOTE**

Battery cabinet wiring assumes using factory supplied wiring and one wire per pole.

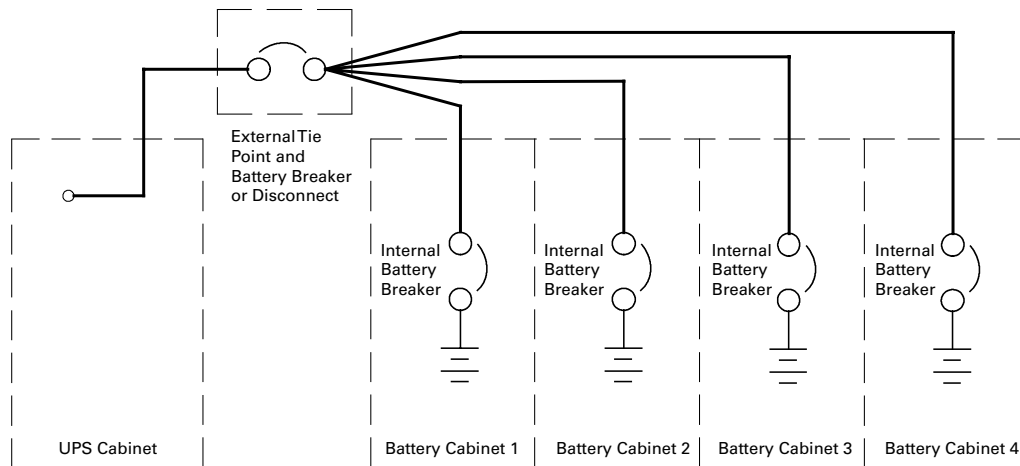
**Figure 27. Eaton 93PM IBC-LW Standalone Power Online – One or Two Cabinets**



**NOTE**

External wiring to be supplied by the customer.

**Figure 28. Eaton 93PM IBC-LW Standalone Power Online – Four Cabinets**



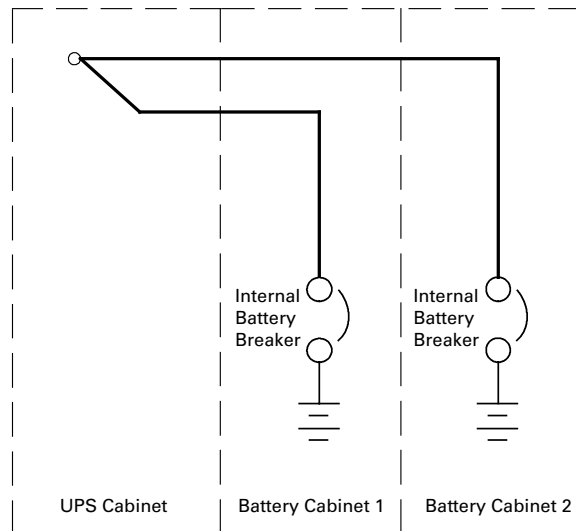
**NOTE 1**

External tie point, battery breaker or disconnect, and wiring to be supplied by the customer.

**NOTE 2**

Up to eight cabinets can be paralleled with a 93PM 100-400 kW UPS.

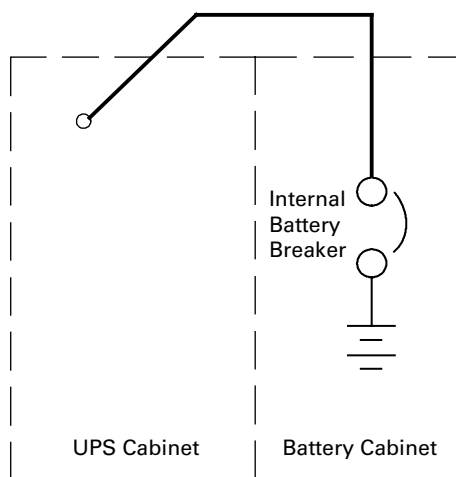
**Figure 29. Eaton 93PM IBC-LHW Line-Up-and-Match Power Oneline**



**NOTE**

Battery cabinet wiring assumes using factory supplied wiring and two wires per pole.

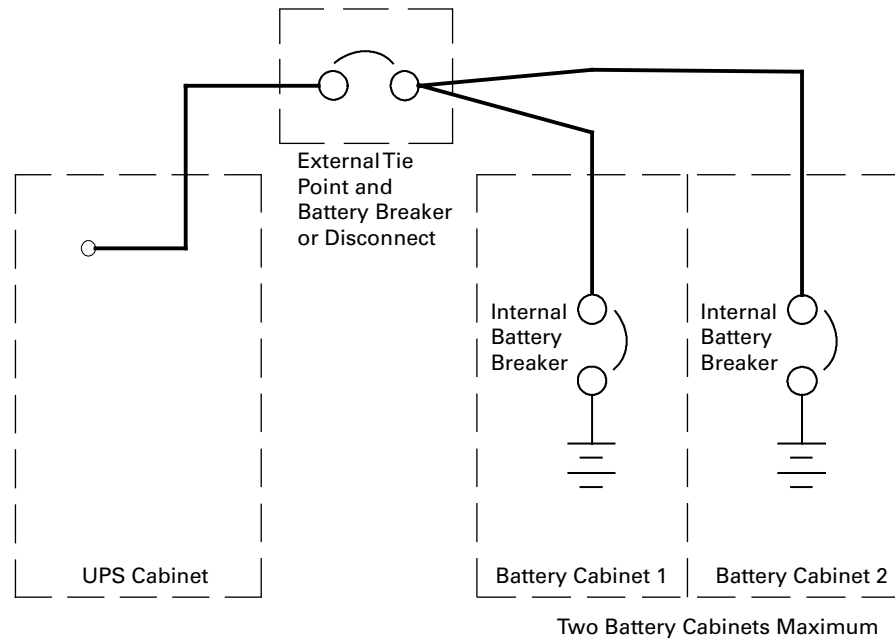
**Figure 30. Eaton 93PM IBC-LHW Standalone Power Online – One Cabinet**



**NOTE**

External wiring to be supplied by the customer.

**Figure 31. Eaton 93PM IBC-LHW Standalone Power Online – Two Cabinets**



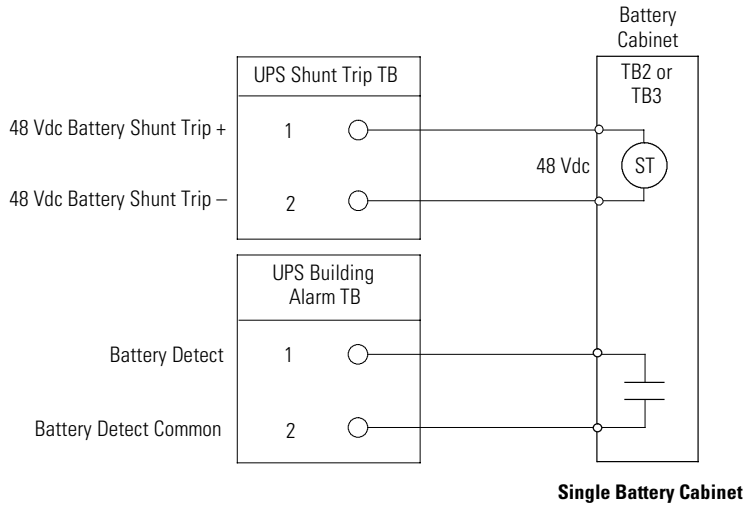
**NOTE 1** External tie point, battery breaker or disconnect, and wiring to be supplied by the customer.

**NOTE 2** Up to four cabinets can be paralleled with a 93PM 100-400 kW UPS.

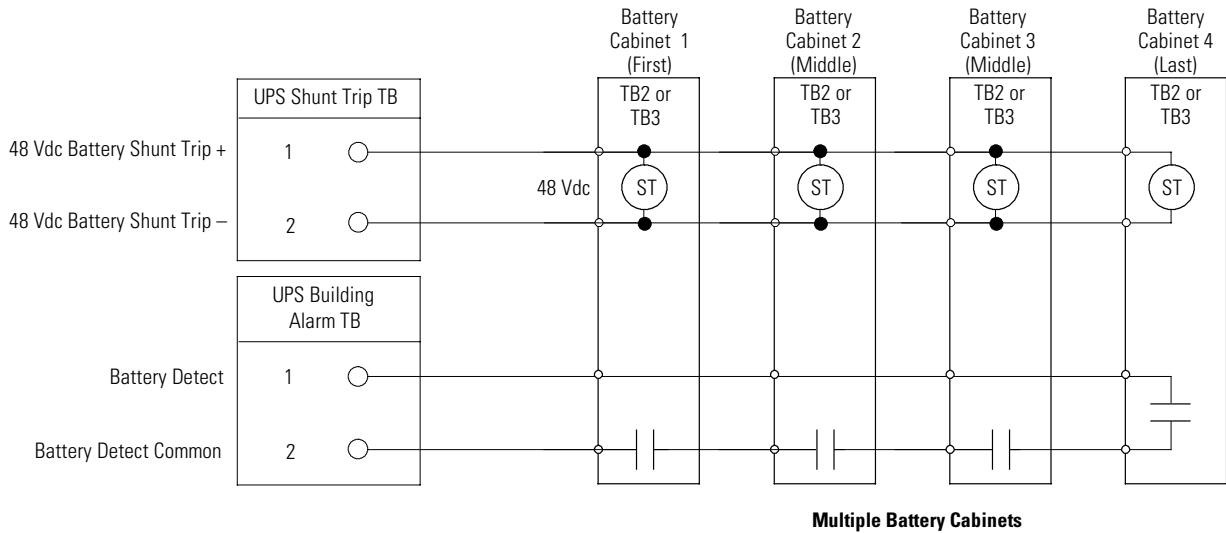
## 5.2 Interface Onelines

[Figure 32](#) shows the UPS and 93PM IBC-LW or 93PM IBC-LHW inter-cabinet interface connection onelines.

**Figure 32. Eaton 93PM Universal Integrated Battery Cabinet Interface Online**



**NOTE** Battery Detect and DC Shunt Trip wiring should be a minimum of 18 AWG.



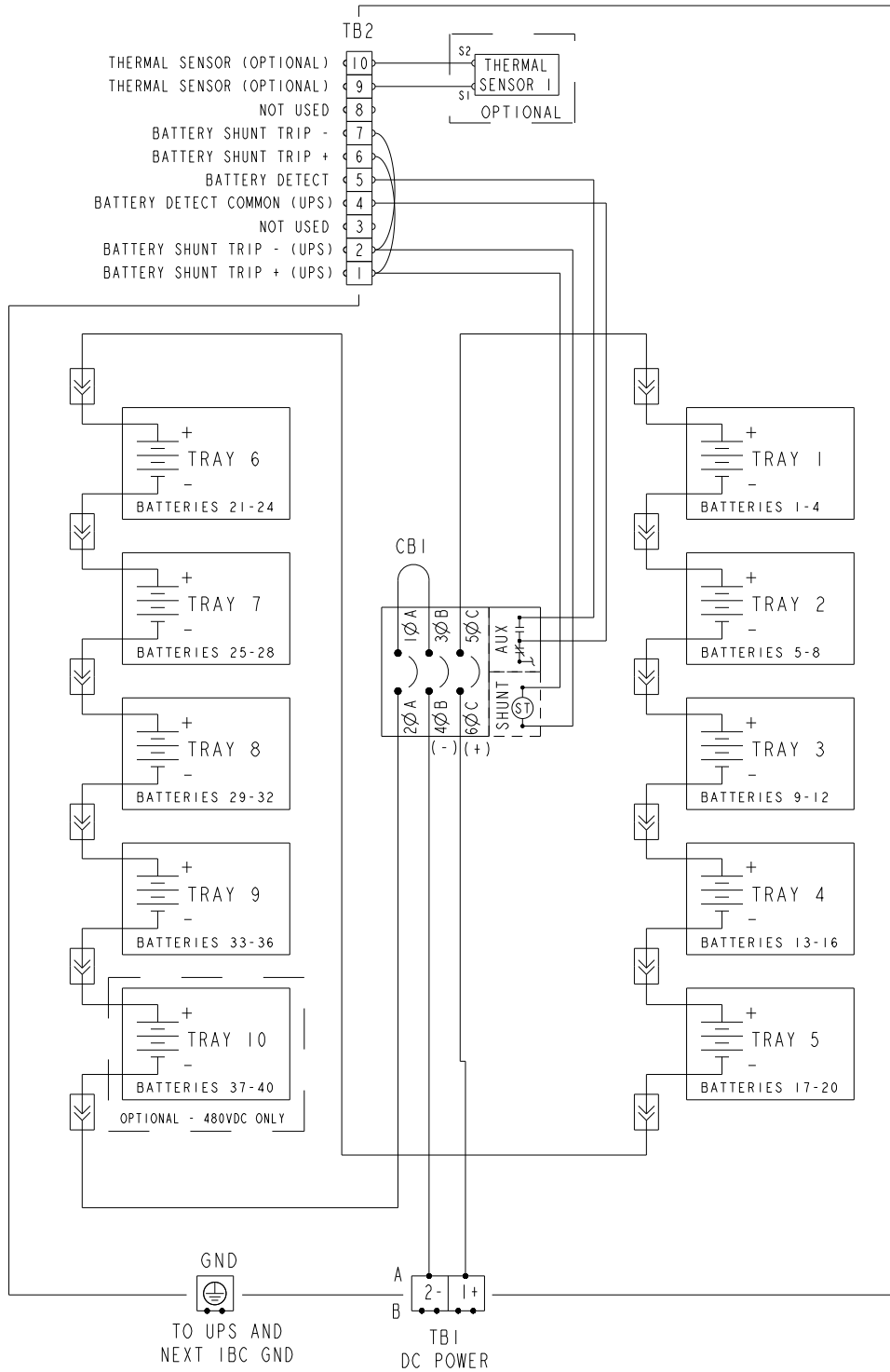
**NOTE 1** Battery Detect and DC Shunt Trip wiring should be a minimum of 18 AWG.

**NOTE 2** Four battery cabinets shown. Battery cabinets 5 through 8 are wired the same.

### 5.3 Schematics

[Figure 33](#) shows the Eaton 93PM IBC-LW and Eaton 93PM IBC-LHW schematic.

**Figure 33. Eaton 93PM Universal Integrated Battery Cabinet Schematic**





## Chapter 6 Maintenance

The components inside the IBC are secured to a sturdy metal frame. All repairable parts and assemblies are located for easy removal, with very little disassembly. This design allows authorized service personnel to perform routine maintenance and servicing quickly.

You must schedule periodic performance checks of the UPS system to keep it running properly. Regular routine checks of operation and system parameters enable your system to function efficiently for many trouble-free years.

### 6.1 Important Safety Instructions

Remember that your UPS system is designed to supply power **EVEN WHEN DISCONNECTED FROM THE UTILITY POWER.**



#### **WARNING**

---

- No user serviceable components.
  - Servicing and maintenance should be performed by qualified service personnel only.
  - **LETHAL VOLTAGE PRESENT.** This unit should not be operated with the cabinet doors open or protective panels removed. Do not make any assumptions about the electrical state of any cabinet in the UPS system.
- 

### 6.2 Performing Preventive Maintenance

The UPS system requires very little preventive maintenance. However, the system should be inspected periodically to verify that the units are operating normally. Record maintenance results and any corrective actions in a suitable log.

#### **6.2.1 DAILY Maintenance**

Perform the following steps daily:

1. Check the area surrounding the UPS system. Ensure the area is not cluttered, allowing free access to the unit.
2. Ensure the air intakes on the Accessory cabinets are not blocked.
3. Ensure the operating environment is within the parameters specified in paragraph [3.2.1 Environmental and Installation Considerations](#) and [Chapter 7 Product Specifications](#).

#### **6.2.2 PERIODIC Maintenance**

Periodic inspections of the IBC should be made to determine if components, wiring, and connections exhibit evidence of overheating. Particular attention should be given to the compression lug connections. Maintenance procedures should specify that the compression lug connections be retorqued to values listed in this manual.

#### **6.2.3 ANNUAL Maintenance**

Annual preventive maintenance should be performed only by authorized service personnel familiar with maintenance and servicing of the UPS system. Contact an Eaton service representative for more information about service offerings.

#### **6.2.4 BATTERY Maintenance**

Contact an Eaton service representative for battery maintenance. Battery replacement and maintenance should be performed only by authorized service personnel.

### 6.2.5 BATTERY Shelf Life

The shelf life for the batteries installed in the IBC is 12 months from the date code on the battery. The recharge date is also stated on a label inside the IBC.

---

 **CAUTION**

---

Failure to recharge the batteries before the expiration of the shelf life will result in reduced discharge time, shorter float service life, and will void the warranty.

---

### 6.3 Recycling the Used Batteries

Contact your local recycling or hazardous waste center for information on proper disposal of the used Valve-Regulated Lead-Acid (VRLA) batteries.

---

 **WARNING**

---

- Do not dispose of the battery or batteries in a fire. Batteries may explode. Proper disposal of batteries is required. Refer to your local codes for disposal requirements.
  - Do not open or mutilate the battery or batteries. Released electrolyte is harmful to the skin and eyes. It may be toxic.
  - A battery can cause electrical shock, burn from high short-circuit current, or fire. Observe proper precautions.
- 

---

 **ATTENTION!**

---

- Une batterie peut présenter un risque de choc électrique, de brûlure, ou d'incendie. Suivre les précautions qui s'imposent.
  - Pour le remplacement, utiliser le même nombre et modèle des batteries.
  - L'élimination des batteries est réglementée. Consulter les codes locaux à cet effet.
- 

---

 **CAUTION**

---

Do not discard the UPS or the UPS batteries in the trash. This product contains sealed, lead-acid batteries and must be disposed of properly. For more information, contact your local recycling/reuse or hazardous waste center.

---

---

 **CAUTION**

---

Do not discard waste electrical or electronic equipment (WEEE) in the trash. For proper disposal, contact your local recycling/reuse or hazardous waste center.

---

### 6.4 Maintenance Training

A basic training course, available from Eaton, gives you a competent working knowledge of the UPS system operation and teaches you how to perform first level corrective maintenance. For more information about training and other services, contact the Customer Reliability Center (see paragraph [1.8 Getting Help](#)).

## Chapter 7 Product Specifications

This section provides the following specifications:

- Model Numbers
- Battery specifications
- Environmental and safety specifications

### 7.1 Model Numbers

The Universal Integrated Battery Cabinet (IBC) is available in two model to meet the needs of the Eaton 93PM UPS product line.

Universal Integrated Battery Cabinet (IBC) Models	Description
Eaton 93PM Universal Integrated Battery Cabinet-Large (IBC-LW) (432V and 480V)	IBC for Eaton 93PM 50 kW UPS
Eaton 93PM Universal Integrated Battery Cabinet-Large High Rate (IBC-LHW) (432V and 480V)	IBC for Eaton 93PM 100 kW UPS
	IBC for Eaton 93PM 150 kW UPS
	IBC for Eaton 93PM 200 kW UPS
	IBC for Eaton 93PM 400 kW UPS

### 7.2 Specifications

The following sections detail the battery specifications and the environmental and safety specifications for the UPS.

#### 7.2.1 Battery Specifications

<b>IBC Battery Types</b>	IBC-LW: E28, 280 W/cell battery, valve-regulated lead-acid (VRLA) IBC-LW: E39, 390 W/cell battery, valve-regulated lead-acid (VRLA) IBC-LW: E54, 540 W/cell battery, valve-regulated lead-acid (VRLA) IBC-LHW: B37, 400 W/cell battery, valve-regulated lead-acid (VRLA) IBC-LHW: E54, 540 W/cell battery, valve-regulated lead-acid (VRLA) IBC-LHW: H41, 414 W/cell battery, valve-regulated lead-acid (VRLA) IBC-LHW: N54, 540 W/cell battery, valve-regulated lead-acid (VRLA)
<b>Number of Strings</b>	1 string
<b>Battery Replacement</b>	Must be replaced by a qualified service technician
<b>Protection</b>	IBC-LW output protected by 300A circuit breaker. IBC-LW output protected by 400A circuit breaker IBC-LHW output protected by 500A circuit breaker.



#### CAUTION

The shelf life for the batteries installed in the IBC is 12 months from the date code on the battery. The recharge date is also stated on a label inside the IBC.

Failure to recharge the batteries before the expiration of the shelf life will result in reduced discharge time, shorter float service life, and will void the warranty.

### 7.2.2 Environmental and Safety Specifications

<b>Operating Temperature</b>	The battery cabinet is rated for operation in up to a 40°C (104°F) ambient temperature.  <b>NOTE</b> Emergency lighting and power equipment battery cabinets (UL924) are rated for operation in a 20°–30°C (68°–86°F) temperature environment. The batteries are rated for a 25°C (77°F) ambient temperature to extend their useful life.
<b>Transit Temperature</b>	-15°C to 40°C (5°F to 104°F)
<b>Storage Temperature</b>	IBC-LW: -15°C to 40°C (5°F to 104°F) IBC-LHW: -15°C to 40°C (5°F to 104°F)
<b>Operating Altitude</b>	Maximum 1500m (5000 ft) at 40°C without derating
<b>Transit Altitude</b>	15000m (49213 ft)
<b>Ventilation</b>	Convection
<b>Relative Humidity (operating and storage)</b>	95%, noncondensing
<b>Acoustical Noise</b>	Not applicable
<b>Safety Conformance</b>	UL1778 5 <sup>th</sup> edition
<b>Agency Markings</b>	cULus
<b>EMC (Class A)</b>	FCC Part 15 Class A and 62040-2 c3

## Chapter 8 Warranty

For warranty information, please refer to the Resources link on our website, [www.eaton.com/93PM](http://www.eaton.com/93PM).

### EQUIPMENT REGISTRATION

Please visit [www.eaton.com/pg/register](http://www.eaton.com/pg/register) to register your new Eaton UPS / Eaton UPS Accessory.

**Model Number:**

---

**Serial Number:**

---



P-164000541 04