

Eaton® 93PM Integrated Accessory Cabinet-Tie

150 kW and 200 kW IAC-T

150 kW and 200 kW IAC-T with MIS

150 kW and 200 kW IAC-T with MIS and MBP

Installation and Operation Manual



Powering Business Worldwide

p/n: P-164000306
Revision 03

IMPORTANT SAFETY INSTRUCTIONS SAVE THESE INSTRUCTIONS

This manual contains important instructions that you should follow during installation and maintenance of the UPS and batteries. Please read all instructions before operating the equipment and save this manual for future reference.

CONSIGNES DE SÉCURITÉ IMPORTANTES – CONSERVER CES INSTRUCTIONS

Ce manuel comporte des instructions importantes que vous êtes invité à suivre lors de toute procédure d'installation et de maintenance des batteries et de l'onduleur. Veuillez consulter entièrement ces instructions avant de faire fonctionner l'équipement et conserver ce manuel afin de pouvoir vous y reporter ultérieurement.



IMPORTANT

To ensure you have the most up-to-date content and information for this product, please review the latest manual revision on our website, www.eaton.com/93PM.

Eaton reserves the right to change specifications without prior notice. Modbus is a registered trademark of Schneider Automation, Inc. MOXA is a registered trademark and MGate is a trademark of MOXA, Inc. Spiralock is a registered trademark of Spiralock Corporation. KIRK is a registered trademark of Kirk Key Interlock company, LLC, a subsidiary of Halma plc. National Electrical Code and NEC are registered trademarks of National Fire Protection Association, Inc. ERIFLEX and FLEXIBAR are registered trademark of Erico International Corporation. All other trademarks are property of their respective companies.

©Copyright 2014-2018 Eaton, Raleigh, NC, USA. All rights reserved. No part of this document may be reproduced in any way without the express written approval of Eaton.

Table of Contents

1 Introduction	1
1.1 Features	1
1.2 Installation Features	1
1.3 Model Configurations	4
1.4 Using This Manual	5
1.5 Conventions Used in This Manual	5
1.6 Symbols, Controls, and Indicators	5
1.7 For More Information	6
1.8 Getting Help	6
1.9 Equipment Registration	6
2 Safety Warnings	7
3 Installation Plan and Unpacking	9
3.1 Creating an Installation Plan	9
3.2 Preparing the Site	9
3.2.1 Environmental and Installation Considerations	9
3.2.2 IAC-T Power Wiring Preparation	15
3.2.3 IAC-T Interface Wiring Preparation	28
3.3 Inspecting and Unpacking the IAC-T	28
4 Installation	31
4.1 Preliminary Installation Information	31
4.2 Unloading the IAC-T from the Pallet	31
4.3 Installing IAC-T External Power Wiring	35
4.3.1 Two-Hole Barrel Lug Terminations to Bus Bar Installation	35
4.3.2 IAC-T without a Maintenance Isolation Switch or Maintenance Bypass Breaker	35
4.3.3 IAC-T with a Maintenance Isolation Switch	41
4.3.4 IAC-T with a Maintenance Isolation Switch and Maintenance Bypass Breaker	46
4.4 Installing IAC-T Interface Connections	56
4.5 Initial Startup	64
4.6 Completing the Installation Checklist	64
4.7 Installation Checklist	65
5 Onelines and Schematics	67
5.1 Onelines	67
5.2 Schematics	69
6 Integrated Accessory Cabinet-Tie Operating Instructions	75
6.1 Circuit Breakers	75
6.2 Using the UPS when an IAC-T is Installed (No MIS or MBP)	76
6.3 Using the UPS when an IAC-T is Installed (with a MIS)	77

Table of Contents

6.4 Using the UPS when an IAC-T is Installed (with a MIS and a MBP)	77
6.4.1 Transferring the UPS to Maintenance Bypass (IAC-T with a MIS and a MBP)	77
6.4.2 Transferring the UPS from Maintenance Bypass (IAC-T with a MIS and a MBP).....	78
7 Maintenance.....	79
7.1 Important Safety Instructions	79
7.2 Performing Preventive Maintenance	79
7.2.1 DAILY Maintenance	79
7.2.2 PERIODIC Maintenance	79
7.2.3 ANNUAL Maintenance.....	79
7.3 Maintenance Training	80
8 Product Specifications	81
8.1 Model Numbers	81
8.2 Specifications	81
8.2.1 Input	81
8.2.2 Output.....	81
8.2.3 Environmental and Safety Specifications.....	81
9 Warranty	83
9.1 Limited Factory Warranty for Three-Phase Eaton 93PM UPS and 93PM UPS Accessory Products.....	83

List of Figures

Figure 1.	Eaton 93PM 150 kW IAC-T or Eaton 93PM 200 kW IAC-T	2
Figure 2.	Two UPS Parallel System – Eaton 93PM 150 kW IAC-T and Two Eaton 93PM 150 kW Capacity UPSs.....	3
Figure 3.	Two UPS Parallel System – Eaton 93PM 200 kW IAC-T and Two Eaton 93PM 200 kW UPSs.....	4
Figure 4.	93PM 200 kW IAC-T Dimensions (Front, Right Side, and Rear Views).....	11
Figure 5.	93PM 200 kW IAC-T Dimensions (Top and Bottom Views).....	12
Figure 6.	Floor Mounting Bracket Dimensions.....	13
Figure 7.	93PM 200 kW IAC-T Center of Gravity.....	14
Figure 8.	Eaton 93PM 150 kW IAC-T or 93PM 200 kW IAC-T as Shipped on Pallet	30
Figure 9.	Removing the Pallet Skids and Supports – Eaton 93PM 150 kW IAC-T and 93PM 200 kW IAC-T	32
Figure 10.	Line-Up-and-Match Wiring Access Locations.....	34
Figure 11.	Typical Bus Bar Barrel Lug Mounting – Hardware Assembly Sequence	35
Figure 12.	Top and Bottom Conduit Landing Wire Entry Location.....	36
Figure 13.	93PM IAC-T Power Terminal Locations – 150 kW (1+1 and 2+0) with No MIS or MBP	38
Figure 14.	93PM IAC-T Power Terminal Locations – 200 kW (1+1 and 2+0) with No MIS or MBP	39
Figure 15.	93PM IAC-T Power Input Terminal Detail – 150 kW (1+1 and 2+0) and 200 kW (1+1 and 2+0) MOB	40
Figure 16.	93PM IAC-T Power Output Terminal Detail – 150 kW (1+1 and 2+0) MOB Load Bus	41
Figure 17.	93PM IAC-T Power Output Terminal Detail – 200 kW (1+1 and 2+0) MOB Load Bus	41
Figure 18.	93PM IAC-T Power Terminal Locations – 150 kW (1+1 and 2+0) and 200 kW (1+1) with MIS	43
Figure 19.	93PM IAC-T Power Terminal Locations – 200 kW (2+0) with MIS	44
Figure 20.	93PM IAC-T Power Output Terminal Detail – 150 kW (1+1 and 2+0) and 200 kW (1+1) with MIS	45
Figure 21.	93PM IAC-T Power Output Terminal Detail – 200 kW (2+0) with MIS and 200 kW (2+0) with MIS and MBP.....	46
Figure 22.	93PM IAC-T Power Terminal Locations – 150 kW (1+1) with MIS and MBP	49
Figure 23.	93PM IAC-T Power Terminal Locations – 150 kW (2+0) with MIS and MBP	50
Figure 24.	93PM IAC-T Power Terminal Locations – 200 kW (1+1) with MIS and MBP	51
Figure 25.	93PM IAC-T Power Terminal Locations – 200 kW (2+0) with MIS and MBP	52
Figure 26.	93PM IAC-T Power Input Terminal Detail – 150 kW (1+1 and 2+0) and 200 kW (1+1) with MIS and MBP.....	53
Figure 27.	93PM IAC-T Power Output Terminal Detail – 150 kW (1+1) with MIS and MBP	54
Figure 28.	93PM IAC-T Power Output Terminal Detail – 150 kW (2+0) with MIS and MBP	54
Figure 29.	93PM IAC-T Power Output Terminal Detail – 200 kW (1+1) with MIS and MBP	55
Figure 30.	93PM IAC-T Power Input Terminal Detail – 200 kW (2+0) with MIS and MBP.....	55
Figure 31.	93PM 200 kW IAC-T Interface Terminal Location	57
Figure 32.	93PM 200 kW IAC-T Interface Terminal Detail – Two MOB.....	58
Figure 33.	MOB and Pull Chain Wiring	61
Figure 34.	150 kW Capacity UPS MBP Interface Terminal Location	62
Figure 35.	150 kW Redundant and 200 kW UPS MBP Interface Terminal Location	63
Figure 36.	UPS MBP Interface Terminal Detail.....	64
Figure 37.	Integrated Accessory Cabinet-Tie (IAC-T) Internal Oneline – 150 kW and 200 kW with Two MOB.....	67

List of Figures

Figure 38.	Integrated Accessory Cabinet-Tie (IAC-T) Internal Oneline – 150 kW (1+1 and 2+0) and 200 kW (1+1) with Two MOBs and MIS	67
Figure 39.	Integrated Accessory Cabinet-Tie (IAC-T) Internal Oneline – 200 kW (2+0) with Two MOBs and MIS	68
Figure 40.	Integrated Accessory Cabinet-Tie (IAC-T) Internal Oneline – 150 kW (1+1 and 2+0) and 200 kW (1+1) with Two MOBs, MIS, and MBP.....	68
Figure 41.	Integrated Accessory Cabinet-Tie (IAC-T) Internal Oneline – 200 kW (2+0) with Two MOBs, MIS, and MBP.....	69
Figure 42.	Eaton 93PM IAC-T Schematic – 150 kW and 200 kW with Two MOBs	70
Figure 43.	Eaton 93PM IAC-T Schematic – 150 kW (1+1 and 2+0) and 200 kW (1+1) with Two MOBs and MIS.....	71
Figure 44.	Eaton 93PM IAC-T Schematic – 200 kW (2+0) with Two MOBs and MIS.....	72
Figure 45.	Eaton 93PM IAC-T Schematic – 150 kW (1+1 and 2+0) and 200 kW (1+1) with Two MOBs, MIS, and MBP.....	73
Figure 46.	Eaton 93PM IAC-T Schematic – 200 kW (2+0) with Two MOBs, MIS, and MBP.....	74
Figure 47.	93PM 150 kW IAC-T or 93PM 200 kW IAC-T Breakers	76

List of Tables

Table 1.	IAC-T Weights	10
Table 2.	IAC-T Cabinet Clearances	10
Table 3.	External Power Wiring Recommendations – Eaton 93PM 150 kW IAC-T – 1+1 and 2+0 Parallel Configurations without MIS and MBP	16
Table 4.	External Power Wiring Recommendations – Eaton 93PM 200 kW IAC-T – 1+1 and 2+0 Parallel Configurations without MIS and MBP	17
Table 5.	External Power Wiring Recommendations – Eaton 93PM 150 kW IAC-T – 1+1 and 2+0 Parallel Configurations with MIS	18
Table 6.	External Power Wiring Recommendations – Eaton 93PM 200 kW IAC-T – 1+1 and 2+0 Parallel Configurations with MIS	19
Table 7.	External Power Wiring Recommendations – Eaton 93PM 150 kW IAC-T – 1+1 and 2+0 Parallel Configurations with MIS and MBP	20
Table 8.	External Power Wiring Recommendations – Eaton 93PM 200 kW IAC-T – 1+1 and 2+0 Parallel Configurations with MIS and MBP	21
Table 9.	External Input Power Cable Terminations – Eaton 93PM 150 kW IAC-T 1+1 and 2+0 Parallel Configurations – No MIS or MBP	22
Table 10.	External Input Power Cable Terminations – Eaton 93PM 200 kW IAC-T 1+1 and 2+0 Parallel Configurations – No MIS or MBP	23
Table 11.	External Input Power Cable Terminations – Eaton 93PM 150 kW IAC-T 1+1 and 2+0 Parallel Configurations – with MIS	24
Table 12.	External Input Power Cable Terminations – Eaton 93PM 200 kW IAC-T 1+1 and 2+0 Parallel Configurations – with MIS	25
Table 13.	External Input Power Cable Terminations – Eaton 93PM 150 kW IAC-T 1+1 and 2+0 Parallel Configurations – with MIS and MBP	26
Table 14.	External Input Power Cable Terminations – Eaton 93PM 200 kW IAC-T 1+1 and 2+0 Parallel Configurations – with MIS and MBP	27
Table 15.	IAC-T Interface Wiring Terminal Block Terminations	58
Table 16.	IAC-T MOB and Pull Chain Interface Terminals	59
Table 17.	IAC-T MOB, MBP, and Pull Chain Interface Terminals	60

List of Tables

Chapter 1 Introduction

The Eaton® Integrated Accessory Cabinet-Tie (IAC-T) is designed for use with the 93PM 150 kW and 200 kW UPS series. The IAC-T provides parallel tie or parallel tie with optional maintenance bypass functions with the configurable features, enabling adaptation and expansion without costly electrical rework.

The IAC-T is housed in single free-standing cabinet with safety shields behind the doors for hazardous voltage protection. The cabinet matches the UPS cabinet in style and color.

NOTE 	Startup and operational checks must be performed by an authorized Eaton Customer Service Engineer, or the warranty terms specified in Chapter 9 Warranty become void. This service is offered as part of the sales contract for the UPS. Contact an Eaton service representative in advance (a minimum two-week notice is required) to reserve a preferred startup date.
--	--

1.1 Features

The following descriptions provide a brief overview of the IAC-T:

- Integrated Accessory Cabinet-Tie (IAC-T) – Module Output Breakers (MOB) 1 and 2 enable up to two UPSs to be paralleled together for redundancy and/or increased capacity.
- Integrated Accessory Cabinet-Tie (IAC-T) with optional MIS – Module Output Breakers (MOB) 1 and 2 enable up to two UPSs to be paralleled together for redundancy and/or increased capacity. A Maintenance Isolation (MIS) breaker provides output control to the critical load for the whole system.
- Integrated Accessory Cabinet-Tie (IAC-T) with optional MIS and MBP – Module Output Breakers (MOB) 1 and 2 enable up to two UPSs to be paralleled together for redundancy and/or increased capacity. Maintenance Bypass (MBP) and Maintenance Isolation (MIS) breakers enable power to completely bypass the UPS externally, allowing the UPS to be safely serviced or replaced without interrupting power to critical systems.

[Figure 1](#) shows the Eaton 93PM 150 kW IAC-T and Eaton 93PM 200 kW IAC-T.

1.2 Installation Features

- The IAC-T is designed to be installed in line-up-and-match or standalone configurations:
 - In line-up-and-match configurations input power wiring is routed through the side panels between the UPS and the IAC-T.
 - In standalone configurations input power wiring is routed using external conduit through top or bottom entry conduit plates.
 - Output wiring is routed using external conduit through top or bottom entry conduit plates.
- To reduce installation time, connections to the MOB and bypass inputs, and critical load output are made to easily accessible mechanical lug terminals located on the breakers or at the front of the cabinet.
- Top exhaust or rear exhaust is available
- The cabinet can be leveled and secured in place using leveling feet

In a line-up-and-match two UPS parallel system the IAC-T is installed centered between the UPS cabinets or other accessory cabinets. All of the UPS cabinets cannot be installed to one side of the IAC-T because of inter-cabinet wiring access constraints. See [Figure 2](#) or [Figure 3](#) for line-up-and-match configuration views.

Figure 1. Eaton 93PM 150 kW IAC-T or Eaton 93PM 200 kW IAC-T

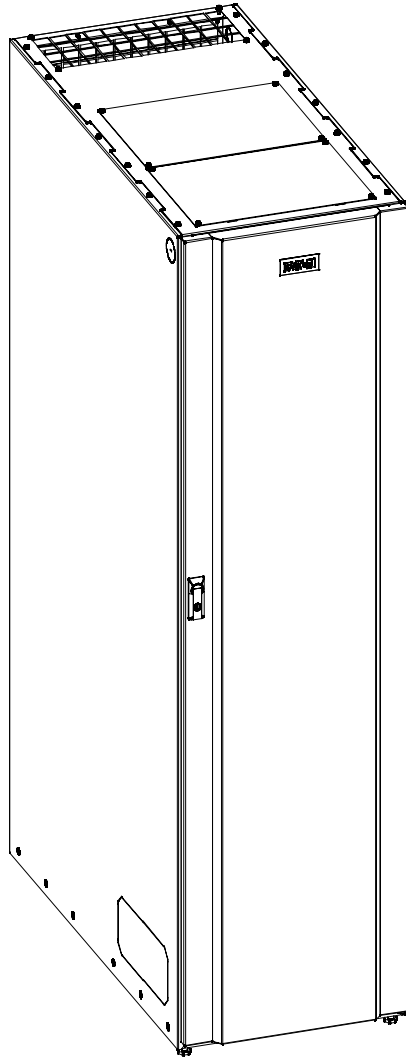

Figure 2. Two UPS Parallel System – Eaton 93PM 150 kW IAC-T and Two Eaton 93PM 150 kW Capacity UPSs

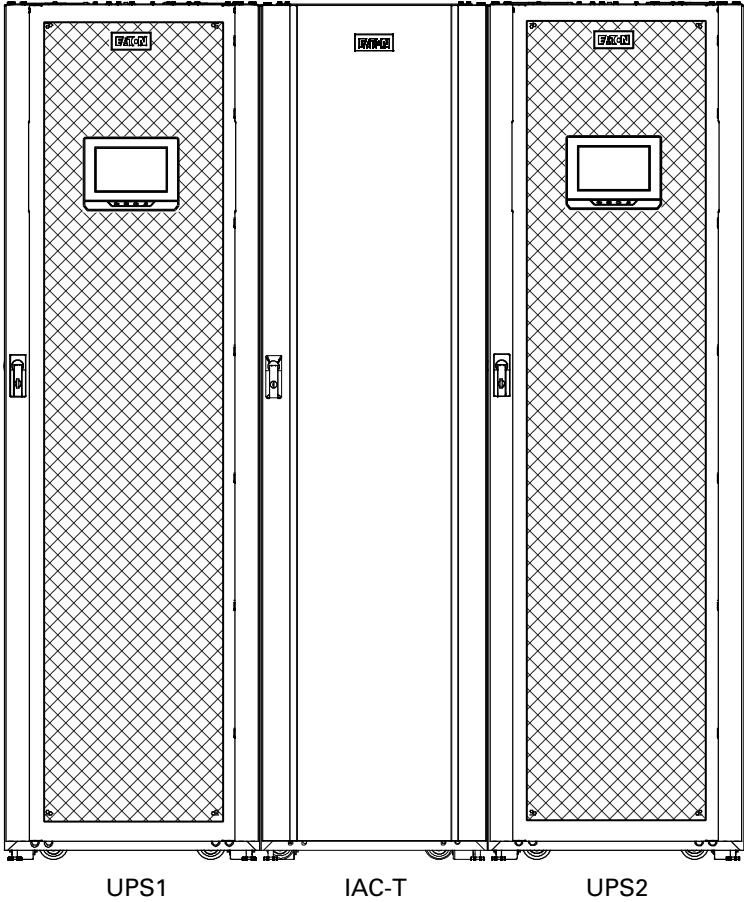
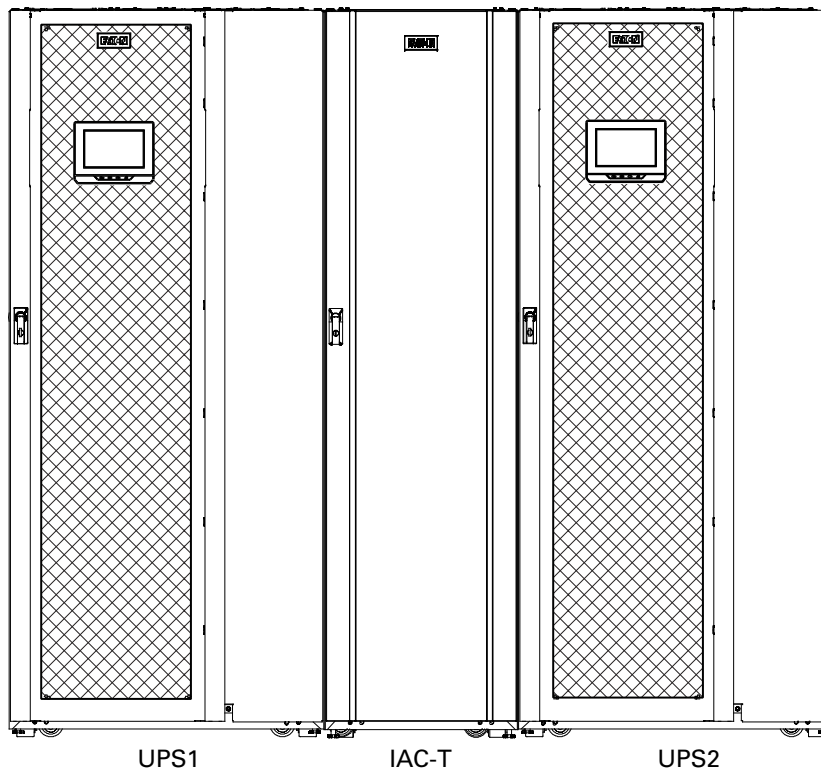

Figure 3. Two UPS Parallel System – Eaton 93PM 200 kW IAC-T and Two Eaton 93PM 200 kW UPSs



1.3 Model Configurations

The following model configurations are available:

- 93PM 150 kW IAC-T
 - Contains two MOBs with auxiliary contacts.
- 93PM 150 kW IAC-T with MIS
 - Contains up to two MOBs and a MIS.
- 93PM 150 kW IAC-T with MIS and MBP
 - Contains up to two MOBs, a MIS, and a MBP with auxiliary contacts.
- 93PM 200 kW IAC-T
 - Contains two MOBs with auxiliary contacts.
- 93PM 200 kW IAC-T with MIS
 - Contains up to two MOBs and a MIS.
- 93PM 200 kW IAC-T with MIS and MBP
 - Contains up to two MOBs, a MIS, and a MBP with auxiliary contacts.

1.4 Using This Manual

This manual describes how to install the IAC-T and is divided into chapters. Read and understand the procedures described to ensure trouble-free installation and operation.

Read through each procedure before beginning the procedure. Perform only those procedures that apply to the UPS system being installed or operated.

1.5 Conventions Used in This Manual

This manual uses these type conventions:

- **Bold type** highlights important concepts in discussions, key terms in procedures, and menu options, or represents a command or option that you type or enter at a prompt.
- *Italic type* highlights notes and new terms where they are defined.
- `Screen type` represents information that appears on the screen or LCD.

Icon	Description
Note	Information notes call attention to important features or instructions.
[Keys]	Brackets are used when referring to a specific key, such as [Enter] or [Ctrl].

In this manual, the term UPS refers only to the UPS cabinet and its internal elements. The term UPS system refers to the entire power protection system – the UPS cabinet, an external battery system, and options or accessories installed.

The term line-up-and-match refers to accessory cabinets that are physically located adjacent to the UPS. The term standalone refers to accessory cabinets that are located separate from the UPS.

1.6 Symbols, Controls, and Indicators

The following are examples of symbols used on the UPS or accessories to alert you to important information:



RISK OF ELECTRIC SHOCK - Observe the warning associated with the risk of electric shock symbol.



CAUTION: REFER TO OPERATOR'S MANUAL - Refer to your operator's manual for additional information, such as important operating and maintenance instructions.



This symbol indicates that you should not discard the UPS or the UPS batteries in the trash. This product contains sealed, lead-acid batteries and must be disposed of properly. For more information, contact your local recycling/reuse or hazardous waste center.



This symbol indicates that you should not discard waste electrical or electronic equipment (WEEE) in the trash. For proper disposal, contact your local recycling/reuse or hazardous waste center.

1.7 For More Information

Refer to the *Eaton 93PM UPS (20150 kVA, 480V 150 kW Capacity Frame) Installation and Operation Manual* or the *Eaton 93PM UPS (20200 kVA, 480V 200 kW Frame) Installation and Operation Manual* for the following additional information:

- UPS, optional components, and accessory installation instructions, including site preparation, planning for installation, and wiring and safety information. Detailed illustrations of cabinets and optional accessories with dimensional and connection point drawings are provided.
- UPS operation, including UPS controls, functions of the UPS, standard features and optional accessories, procedures for starting and stopping the UPS, and information about maintenance and responding to system events.
- Communication capabilities of the UPS system.

Refer to the *Eaton 93PM Integrated Accessory Cabinet-Distribution (50 kW IAC-D, 100 kW IAC-D, 150 kW, and 200 kW IAC-D) Installation and Operation Manual* for the following additional information:

- Installation instructions, including site preparation, planning for installation, wiring and safety information, and detailed illustrations of cabinets with dimensional and connection point drawings
- Operation, including breakers, standard features and optional accessories, procedures for using the tie and bypass functions, and information about maintenance

Visit www.eaton.com/powerquality or contact an Eaton service representative for information on how to obtain copies of these manuals.

1.8 Getting Help

If help is needed with any of the following:

Scheduling initial startup

Regional locations and telephone numbers

A question about any of the information in this manual

A question this manual does not answer

Please call the Help Desk at:

United States:

1-800-843-9433

Canada:

1-800-461-9166 ext 260

All other countries:

Call your local service representative

Please use the following e-mail address for manual comments, suggestions, or to report an error in this manual:

E-ESSDocumentation@eaton.com

1.9 Equipment Registration

Please visit www.eaton.com/pg/register to register your new Eaton UPS / Eaton UPS Accessory.

Model Number:

Serial Number:

Chapter 2 Safety Warnings

IMPORTANT SAFETY INSTRUCTIONS SAVE THESE INSTRUCTIONS

This manual contains important instructions that should be followed during installation and maintenance of the UPS system and batteries. Read all instructions before operating the equipment and save this manual for future reference.

The UPS system is designed for industrial or computer room applications, and contains safety shields behind the door and front panels. However, the UPS system is a sophisticated power system and should be handled with appropriate care.

DANGER

This UPS system contains LETHAL VOLTAGES. All repairs and service should be performed by AUTHORIZED SERVICE PERSONNEL ONLY. There are NO USER SERVICEABLE PARTS inside the UPS.

WARNING

- The UPS system is powered by its own energy source (batteries). The output terminals may carry live voltage even when the UPS is disconnected from an AC source.
- To reduce the risk of fire or electric shock, install this UPS system in a temperature and humidity controlled, indoor environment, free of conductive contaminants. Ambient temperature must not exceed 40°C (104°F). Do not operate near water or excessive humidity (95% maximum). The system is not intended for outdoor use.
- As a result of the connected loads high leakage current is possible. Connection to earth ground is required for safety and proper product operation. Do not check UPS system operation by any action that includes removal of the earth (ground) connection with loads attached.
- Ensure all power is disconnected before performing installation or service.
- ELECTRIC ENERGY HAZARD. Do not attempt to alter any UPS system or battery wiring or connectors. Attempting to alter wiring can cause injury.

CAUTION

- Installation or servicing should be performed by qualified service personnel knowledgeable of UPS and battery systems, and required precautions. Keep unauthorized personnel away from equipment. Consider all warnings, cautions, and notes before installing or servicing equipment.
 - Keep the Accessory cabinet doors closed and front panels installed to ensure proper cooling airflow and to protect personnel from dangerous voltages inside the unit.
 - Do not install or operate the UPS system close to gas or electric heat sources.
 - The operating environment should be maintained within the parameters stated in this manual.
 - Keep surroundings uncluttered, clean, and free from excess moisture.
 - Observe all DANGER, CAUTION, and WARNING notices affixed to the inside and outside of the equipment.
-

Safety Warnings

Chapter 3 Installation Plan and Unpacking

This chapter includes planning and unpacking for the Eaton 93PM Integrated Accessory Cabinet-Tie (IAC-T).

Use the following basic sequence of steps to install the IAC-T:

1. Create an installation plan for the IAC-T.
2. Prepare your site for the IAC-T.
3. Inspect and unpack the IAC-T.
4. Unload and install the IAC-T, and wire the system.
5. Complete the Installation Checklist.
6. Have authorized service personnel perform preliminary operational checks and start up the system.



NOTE

Startup and operational checks must be performed by an authorized Eaton Customer Service Engineer, or the warranty terms specified in [Chapter 9 Warranty](#) become void. This service is offered as part of the sales contract for the UPS. Contact an Eaton service representative in advance (usually a two-week notice is required) to reserve a preferred startup date.

3.1 Creating an Installation Plan

Before installing the IAC-T, read and understand how this manual applies to the system being installed. Use the procedures and illustrations in this section to create a logical plan for installing the IAC-T. This section contains the following information:

- Physical features and requirements, including dimensions
- Power wiring installation notes
- Location of conduit and wire entry landing plates
- Location of power terminals

3.2 Preparing the Site

For the UPS system to operate at peak efficiency, the installation site should meet the environmental parameters outlined in this manual. The operating environment must meet the weight, clearance, and environmental requirements specified for the applicable accessory cabinet. Specifications subject to change.

3.2.1 Environmental and Installation Considerations

The UPS system installation, including the IAC-T, must meet the following guidelines:

- The system must be installed on a level floor suitable for computer or electronic equipment.
- The system must be operated at an altitude no higher than 1500m (5000 ft) without derating. For additional assistance with high altitude operation, contact an Eaton service representative (see paragraph [1.8 Getting Help](#)).
- The system must be installed in a temperature and humidity controlled indoor area free of conductive contaminants.

Failure to follow guidelines may void your warranty.

The basic environmental requirements for operation of the IAC-T are:

- Ambient Temperature Range: 5–40°C (41–104°F)
- Recommended Operating Range: 5–40°C (41–104°F)

- Maximum Relative Humidity: 5–95%, noncondensing

The IAC-T operating environment must meet the weight requirements shown in [Table 1](#) and the size requirements shown in [Figure 4](#) through [Figure 7](#). Dimensions are in millimeters (inches).

Table 1. IAC-T Weights

Model	Shipping	Weight kg (lb)	
		Installed	Point Loading
Eaton 93PM 200 kW IAC-T (2+0) – Two MOBs with MIS and MBP	262 (578)	240 (530)	4 at 60.0 (132.5)

The IAC-T uses convection cooling to regulate internal component temperature. Air inlets are in the front of the cabinet and outlets are on top or in the back of the cabinet. Allow clearance in front of and on top or in back of the cabinet for proper air circulation. The clearances required around the IAC-T are shown in [Table 2](#).

Table 2. IAC-T Cabinet Clearances

From Top of Cabinet with Rear Exhaust Option	304.8 mm (8") working space
From Top of Cabinet with Top Exhaust Option	304.8 mm (8") minimum clearance for ventilation
From Front of Cabinet	914.4 mm (36") working space
From Back of Cabinet with Top Exhaust Option	None Required
From Back of Cabinet with Rear Exhaust Option	203.2 mm (8") minimum clearance for ventilation
From Back of Cabinet – Seismic Installation	914.4 mm (36") working space
From Right Side of Cabinet	None Required
From Left Side of Cabinet	None Required

Figure 4. 93PM 200 kW IAC-T Dimensions (Front, Right Side, and Rear Views)

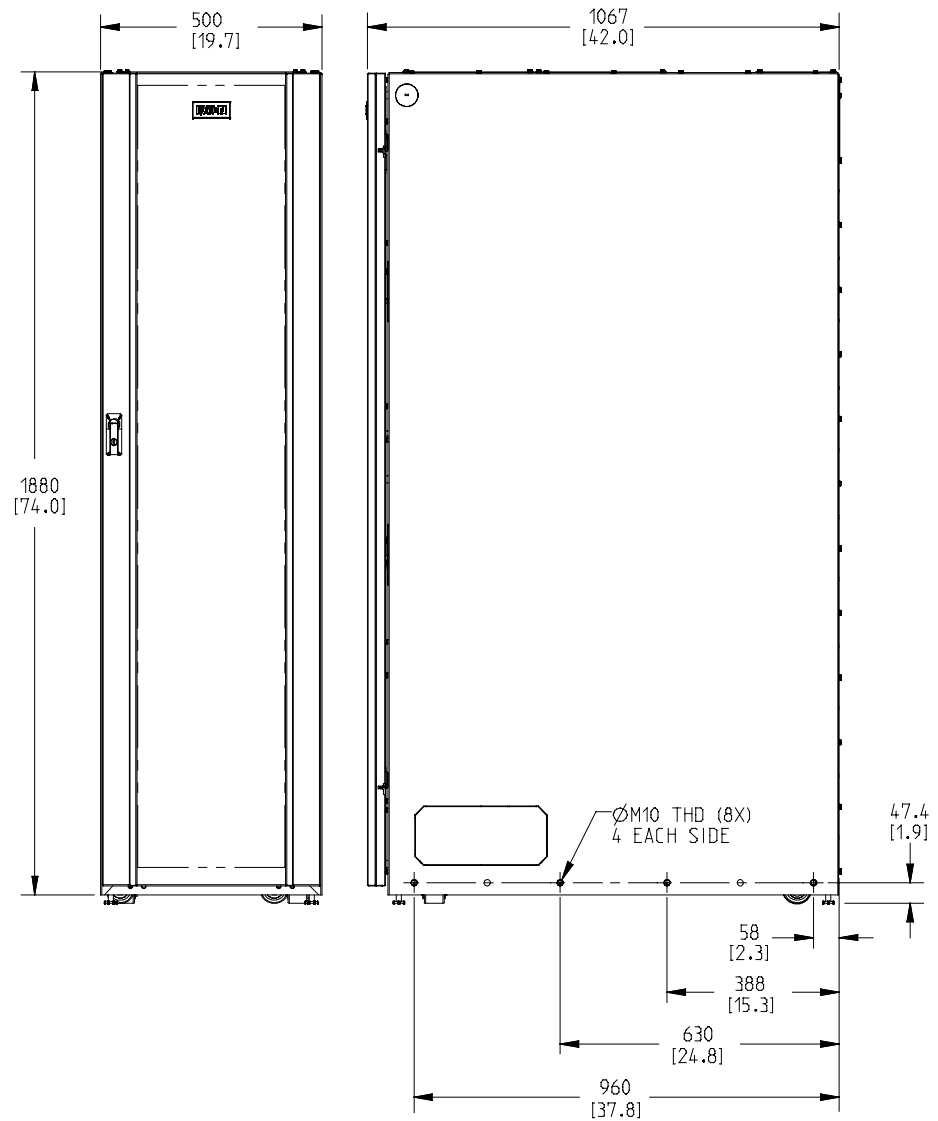

Dimensions are in millimeters [inches]

Figure 5. 93PM 200 kW IAC-T Dimensions (Top and Bottom Views)

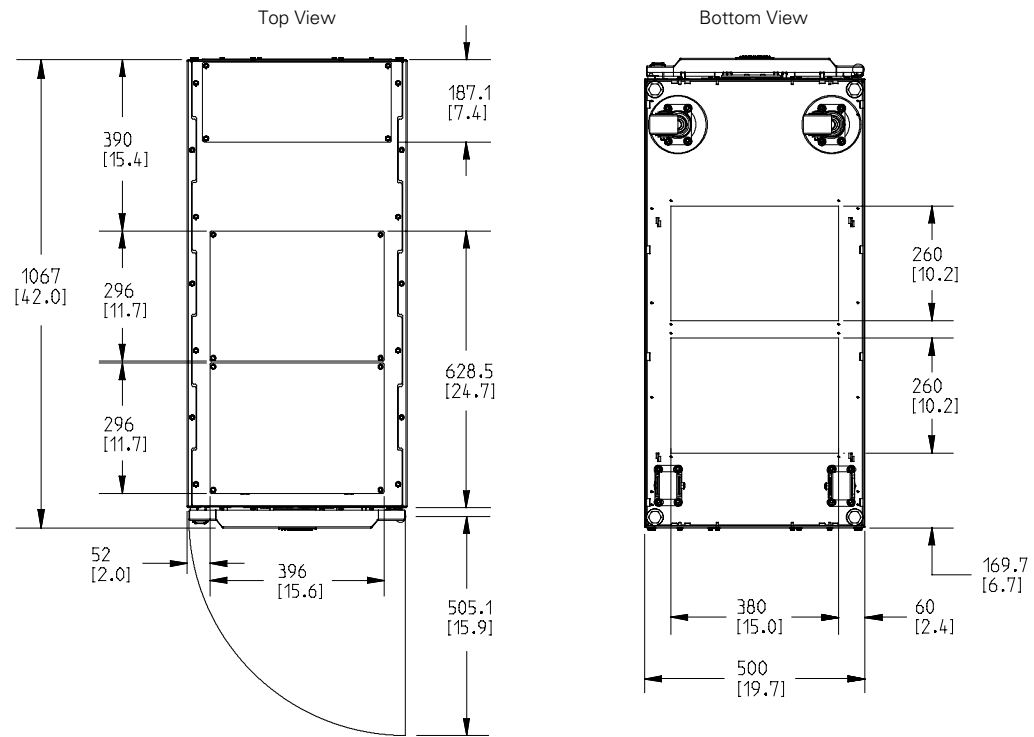

Dimensions are in millimeters [inches]

Figure 6. Floor Mounting Bracket Dimensions

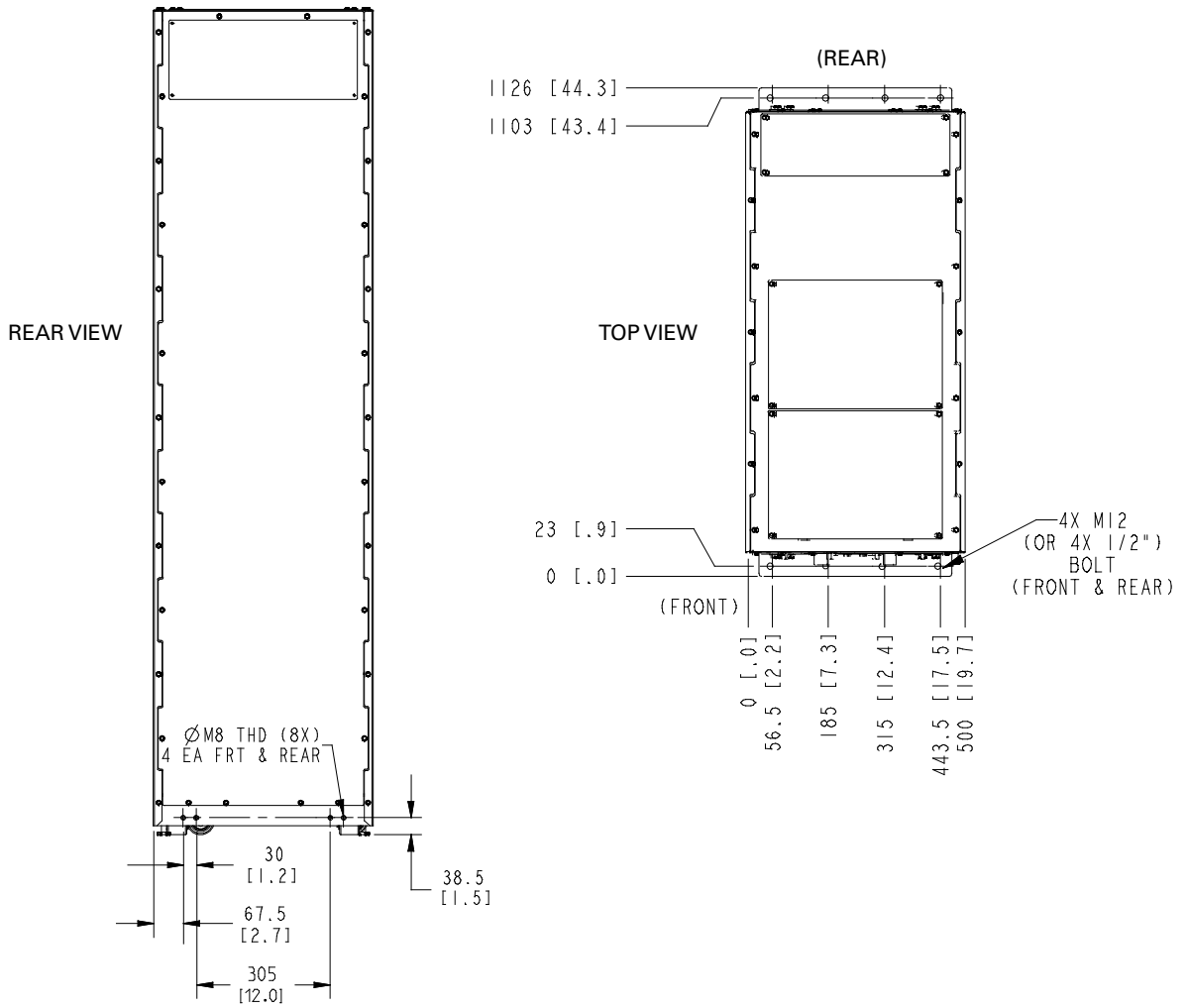

Dimensions are in millimeters [inches]

Figure 7. 93PM 200 kW IAC-T Center of Gravity

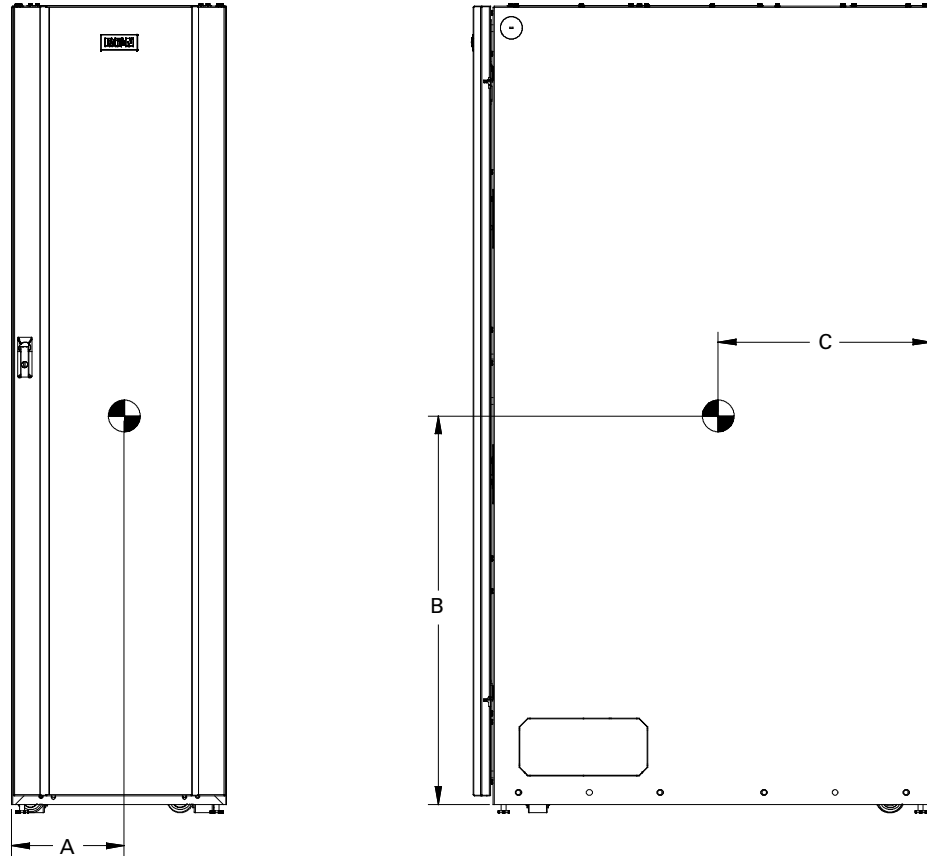

Center of Gravity Dimensions, See Figure 7.				
	A mm (in)	B mm (in)	C mm (in)	Installed Weight kg (lb)
200kW IAC-T (2+0) Two MOBs with MIS and MBP	245 (10)	891 (35)	659 (26)	240 (530)

3.2.2 IAC-T Power Wiring Preparation

Read and understand the following notes while planning and performing the installation:



As a result of the connected loads high leakage current is possible. Connection to earth ground is required for safety and proper product operation. Do not check IAC-T operation by any action that includes removal of the earth (ground) connection with loads attached.

- Refer to national and local electrical codes for acceptable external wiring practices.
- For external wiring, use 90°C rated copper wire with the ampacity based on 75°C copper stranded wire. Wire sizes listed in [Table 3](#) through [Table 8](#) are for copper wiring only. If wire is run in an ambient temperature greater than 40°C, higher temperature wire and/or larger size wire may be necessary. Wire sizes are based on using the specified breakers.
- The IAC-T AC output wiring to the critical load for 1+1 parallel configuration should be sized the same as if wiring a 2+0 parallel system if a Maintenance Isolation Switch (MIS) is not installed in the IAC-T.
- Recommended wire sizes are based on NFPA National Electrical Code® (NEC®)70 Table 310.15(B)(16) 75° C ampacity with 40°C ambient correction factors.
- A neutral conductor is not used from the source or supplied to the load.
- Refer to NEC Article 250 and local codes for proper grounding practices.
- Phase rotation must be clockwise starting with phase A (rotation A,B,C).
- Per NEC Article 300-20(a), all three-phase conductors must be run in the same conduit. A ground wire must be run in the same conduit as the phase conductors.
- Conduit is to be sized to accommodate three phase conductors and one ground conductor.
- Refer to the appropriate Eaton 93PM UPS Installation and Operation manual listed in paragraph [1.7 For More Information](#) for UPS cabinet conduit and terminal specifications and locations.
- Material and labor for external wiring requirements are to be provided by the customer.
- The term line-up-and-match refers to accessory cabinets that are physically located adjacent to the UPS. The term standalone refers to accessory cabinets that are located separate from the UPS.

For Integrated Accessory Cabinet-Tie (IAC-T) external power wiring requirements, including the minimum AWG size of external wiring, see [Table 3](#) through [Table 8](#). Wire sizes listed are for copper wiring only.

Table 3. External Power Wiring Recommendations – Eaton 93PM 150 kW IAC-T – 1+1 and 2+0 Parallel Configurations without MIS and MBP

Basic Unit Rating	Units	Rating 60 Hz	
		kW	150
Input/Output Voltage	Volts	480/480	480/480
Parallel Configuration	—	1+1	2+0
AC Input from each UPS	Maximum Amps	180	180
Full Load Current from each UPS (3) Phases, (1) Ground	A		
Minimum Conductor Size (Phase A, B, and C) Number per Phase	AWG or kcmil (each)	4/0 (2)	4/0 (2)
Minimum Conductor Size (Ground) Number per Phase	— AWG or kcmil (each)	#4 (1)	#4 (1)
AC Output to Critical Load	Maximum Amps	180	360
Full Load Current (3) Phases, (1) Ground	B		
Minimum Conductor Size (Phase A, B, and C) Number per Phase	AWG or kcmil (each)	#1 (4)	#1 (4)
Building and Load Ground	— AWG or kcmil (each)	#4 (2)	#4 (2)
Minimum Conductor Size (Ground) Number			
NOTE Callout letters A and B map to Figure 37 .			

Table 4. External Power Wiring Recommendations – Eaton 93PM 200 kW IAC-T – 1+1 and 2+0 Parallel Configurations without MIS and MBP

	Units	Rating 60 Hz	
Basic Unit Rating	kW	200	200
Input/Output Voltage	Volts	480/480	480/480
Parallel Configuration	—	1+1	2+0
AC Input from each UPS Full Load Current from each UPS (3) Phases, (1) Ground	Maximum Amps	240	240
Minimum Conductor Size (Phase A, B, and C) Number per Phase	—	AWG or kcmil	500
		(each)	(1)
Minimum Conductor Size (Ground) Number per Phase	—	AWG or kcmil	#4
		(each)	(1)
AC Output to Critical Load Full Load Current (3) Phases, (1) Ground	Maximum Amps	240	480
Minimum Conductor Size (Phase A, B, and C) Number per Phase	—	AWG or kcmil	4/0
		(each)	(2)
Building and Load Ground Minimum Conductor Size (Ground) Number	—	AWG or kcmil	#4
		(each)	(2)
NOTE Callout letters A and B map to Figure 37 .			

Table 5. External Power Wiring Recommendations – Eaton 93PM 150 kW IAC-T – 1+1 and 2+0 Parallel Configurations with MIS

	Units	Rating 60 Hz	
	Basic Unit Rating	kW	150
Input/Output Voltage	Volts	480/480	480/480
Parallel Configuration	—	1+1	2+0
AC Input from each UPS Full Load Current from each UPS (3) Phases, (1) Ground	Maximum Amps	180	180
Minimum Conductor Size (Phase A, B, and C) Number per Phase	—	AWG or kcmil	4/0
		(each)	(2)
Minimum Conductor Size (Ground) Number per Phase	—	AWG or kcmil	#4
		(each)	(1)
AC Output to Critical Load Full Load Current (3) Phases, (1) Ground	Maximum Amps	180	360
Minimum Conductor Size (Phase A, B, and C) Number per Phase	—	AWG or kcmil	#1
		(each)	(2)
Building and Load Ground Minimum Conductor Size (Ground) Number	—	AWG or kcmil	#4
		(each)	(2)
NOTE Callout letters A and B map to Figure 38 .			

Table 6. External Power Wiring Recommendations – Eaton 93PM 200 kW IAC-T – 1+1 and 2+0 Parallel Configurations with MIS

	Units	Rating 60 Hz	
Basic Unit Rating	kW	200	200
Input/Output Voltage	Volts	480/480	480/480
Parallel Configuration	—	1+1	2+0
AC Input from each UPS Full Load Current from each UPS (3) Phases, (1) Ground	Maximum Amps	240	240
Minimum Conductor Size (Phase A, B, and C) Number per Phase	—	AWG or kcmil	500
		(each)	(1)
Minimum Conductor Size (Ground) Number per Phase	—	AWG or kcmil	#4
		(each)	(1)
AC Output to Critical Load Full Load Current (3) Phases, (1) Ground	Maximum Amps	240	480
Minimum Conductor Size (Phase A, B, and C) Number per Phase	—	AWG or kcmil	2/0
		(each)	(2)
Building and Load Ground Minimum Conductor Size (Ground) Number	—	AWG or kcmil	#4
		(each)	(2)
NOTE Callout letters A and B map to Figure 38 and Figure 39 .			

Table 7. External Power Wiring Recommendations – Eaton 93PM 150 kW IAC-T – 1+1 and 2+0 Parallel Configurations with MIS and MBP

Basic Unit Rating	Units	Rating 60 Hz	
	kW	150	150
Input/Output Voltage	Volts	480/480	480/480
Parallel Configuration	—	1+1	2+0
AC Input from each UPS Full Load Current from each UPS (3) Phases, (1) Ground	Maximum Amps	180	180
Minimum Conductor Size (Phase A, B, and C) Number per Phase	A	AWG or kcmil	4/0
		(each)	(2)
Minimum Conductor Size (Ground) Number per Phase	—	AWG or kcmil	#4
		(each)	(1)
AC Input to Maintenance Bypass (3) Phases, (1) Ground	Maximum Amps	180	360
Minimum Conductor Size (Phase A, B, and C) Number per Phase	B	AWG or kcmil	#1
		(each)	(2)
Minimum Conductor Size (Phase A, B, and C) Number per Phase	C	AWG or kcmil	#1
		(each)	(2)
AC Output to Critical Load Full Load Current (3) Phases, (1) Ground	Maximum Amps	180	360
Minimum Conductor Size (Phase A, B, and C) Number per Phase	C	AWG or kcmil	#1
		(each)	(2)
Building and Load Ground Minimum Conductor Size (Ground) Number	—	AWG or kcmil	#4
		(each)	(2)
NOTE Callout letters A and B map to Figure 40 .			

Table 8. External Power Wiring Recommendations – Eaton 93PM 200 kW IAC-T – 1+1 and 2+0 Parallel Configurations with MIS and MBP

Basic Unit Rating	Units	Rating 60 Hz	
	kW	200	200
Input/Output Voltage	Volts	480/480	480/480
Parallel Configuration	—	1+1	2+0
AC Input from each UPS Full Load Current from each UPS (3) Phases, (1) Ground	Maximum Amps	240	240
Minimum Conductor Size (Phase A, B, and C) Number per Phase	AWG or kcmil (each)	500	500
		(1)	(1)
Minimum Conductor Size (Ground) Number per Phase	— AWG or kcmil (each)	#4	#4
		(1)	(1)
AC Input to Maintenance Bypass (3) Phases, (1) Ground	Maximum Amps	240	480
Minimum Conductor Size (Phase A, B, and C) Number per Phase	AWG or kcmil (each)	2/0	2/0
		(2)	(4)
AC Output to Critical Load Full Load Current (3) Phases, (1) Ground	Maximum Amps	240	480
Minimum Conductor Size (Phase A, B, and C) Number per Phase	AWG or kcmil (each)	2/0	2/0
		(2)	(4)
Building and Load Ground Minimum Conductor Size (Ground) Number	— AWG or kcmil (each)	#4 (2)	#4 (2)
NOTE Callout letters A and B map to Figure 40 and Figure 41 .			

The power wiring terminals are pressure terminations, UL and CSA rated, M8 2-stud type terminals, or 2-bolt bus bar mounting for standard NEMA 2-hole barrel lugs. See [Table 10](#), [Table 12](#), or [Table 13](#) for IAC-T external input power cable terminations.

[Figure 13](#) or [Figure 14](#) shows the location of the IAC-T power cable terminals.

Table 9. External Input Power Cable Terminations – Eaton 93PM 150 kW IAC-T 1+1 and 2+0 Parallel Configurations – No MIS or MBP

Terminal Function	Terminal	Function	Number and Size of Pressure Termination (AWG or kcmil)	Tightening Torque Nm (lb in)	Size Screw and Type
AC Input to MOB 1 from UPS 1	MOB1-1A	Phase A	2 – #2-500	42 (372)	5/16" Hex
	MOB1-3B	Phase B	2 – #2-500	42 (372)	5/16" Hex
	MOB1-5C	Phase C	2 – #2-500	42 (372)	5/16" Hex
	GND	Ground	2 – #14- 1/0	5.1 (45)	Slotted
AC Input to MOB 2 from UPS 2	MOB2-1A	Phase A	2 – #2-500	42 (372)	5/16" Hex
	MOB2-3B	Phase B	2 – #2-500	42 (372)	5/16" Hex
	MOB2-5C	Phase C	2 – #2-500	42 (372)	5/16" Hex
	TBG	Ground	2 – #14- 1/0	5.1 (45)	Slotted
AC Output to Critical Load (1+1 and 2+0)	Load Bus A	Phase A	4 – #6-350	42 (372)	5/16" Hex
	Load Bus B	Phase B	4 – #6-350	42 (372)	5/16" Hex
	Load Bus C	Phase C	4 – #6-350	42 (372)	5/16" Hex
Building and Load Ground	TBG	Ground	10 – #14-1/0	5.1 (45)	Slotted

Table 10. External Input Power Cable Terminations – Eaton 93PM 200 kW IAC-T 1+1 and 2+0 Parallel Configurations – No MIS or MBP

Terminal Function	Terminal	Function	Number and Size of Pressure Termination (AWG or kcmil)	Tightening Torque Nm (lb in)	Size Screw and Type
AC Input to MOB 1 from UPS 1	MOB1-1A	Phase A	2 – #2-500	42 (372)	5/16" Hex
	MOB1-3B	Phase B	2 – #2-500	42 (372)	5/16" Hex
	MOB1-5C	Phase C	2 – #2-500	42 (372)	5/16" Hex
	GND	Ground	2 – #14- 1/0	5.1 (45)	Slotted
AC Input to MOB 2 from UPS 2	MOB2-1A	Phase A	2 – #2-500	42 (372)	5/16" Hex
	MOB2-3B	Phase B	2 – #2-500	42 (372)	5/16" Hex
	MOB2-5C	Phase C	2 – #2-500	42 (372)	5/16" Hex
	TBG	Ground	2 – #14- 1/0	5.1 (45)	Slotted
AC Output to Critical Load (1+1 and 2+0)	Load Bus A	Phase A	2 – 2 bolt bus bar mounting	35 (310)	M12 Hex (19 mm Hex Head)
	Load Bus B	Phase B	2 – 2 bolt bus bar mounting	42 (372)	M12 Hex (19 mm Hex Head)
	Load Bus C	Phase C	2 – 2 bolt bus bar mounting	42 (372)	M12 Hex (19 mm Hex Head)
Building and Load Ground	TBG	Ground	10 – #14-1/0	5.1 (45)	Slotted

The torque values listed for the M8 studs in [Table 11](#) and [Table 12](#) are the maximum allowable. Tightening further will risk breaking or twisting the stud.

[Figure 18](#) or [Figure 19](#) shows the location of the IAC-T power cable terminals.

Table 11. External Input Power Cable Terminations – Eaton 93PM 150 kW IAC-T 1+1 and 2+0 Parallel Configurations – with MIS

Terminal Function	Terminal	Function	Number and Size of Pressure Termination (AWG or kcmil)	Tightening Torque Nm (lb in)	Size Screw and Type
AC Input to MOB 1 from UPS 1	MOB1-1A	Phase A	2 – #2-500	42 (372)	5/16" Hex
	MOB1-3B	Phase B	2 – #2-500	42 (372)	5/16" Hex
	MOB1-5C	Phase C	2 – #2-500	42 (372)	5/16" Hex
	GND	Ground	2 – #14- 1/0	5.1 (45)	Slotted
AC Input to MOB 2 from UPS 2	MOB2-1A	Phase A	2 – #2-500	42 (372)	5/16" Hex
	MOB2-3B	Phase B	2 – #2-500	42 (372)	5/16" Hex
	MOB2-5C	Phase C	2 – #2-500	42 (372)	5/16" Hex
	TBG	Ground	2 – #14- 1/0	5.1 (45)	Slotted
AC Output to Critical Load (1+1 and 2+0)	MIS- 2A	Phase A	1 – 2 stud bus bar mounting	12.2 (108)	M8 Stud with 13 mm Hex Nut
	MIS- 4B	Phase B	1 – 2 stud bus bar mounting	12.2 (108)	M8 Stud with 13 mm Hex Nut
	MIS- 6C	Phase C	1 – 2 stud bus bar mounting	12.2 (108)	M8 Stud with 13 mm Hex Nut
Building and Load Ground	TBG	Ground	10 – #14-1/0	5.1 (45)	Slotted

Table 12. External Input Power Cable Terminations – Eaton 93PM 200 kW IAC-T 1+1 and 2+0 Parallel Configurations – with MIS

Terminal Function	Terminal	Function	Number and Size of Pressure Termination (AWG or kcmil)	Tightening Torque Nm (lb in)	Size Screw and Type
AC Input to MOB 1 from UPS 1	MOB1–1A	Phase A	2 – #2–500	42 (372)	5/16" Hex
	MOB1–3B	Phase B	2 – #2–500	42 (372)	5/16" Hex
	MOB1–5C	Phase C	2 – #2–500	42 (372)	5/16" Hex
	GND	Ground	2 – #14– 1/0	5.1 (45)	Slotted
AC Input to MOB 2 from UPS 2	MOB2–1A	Phase A	2 – #2–500	42 (372)	5/16" Hex
	MOB2–3B	Phase B	2 – #2–500	42 (372)	5/16" Hex
	MOB2–5C	Phase C	2 – #2–500	42 (372)	5/16" Hex
	TBG	Ground	2 – #14– 1/0	5.1 (45)	Slotted
AC Output to Critical Load (1+1)	MIS– 2A	Phase A	1 – 2 stud bus bar mounting	12.2 (108)	M8 Stud with 13 mm Hex Nut
	MIS– 4B	Phase B	1 – 2 stud bus bar mounting	12.2 (108)	M8 Stud with 13 mm Hex Nut
	MIS– 6C	Phase C	1 – 2 stud bus bar mounting	12.2 (108)	M8 Stud with 13 mm Hex Nut
AC Output to Critical Load (2+0)	Load Bus A	Phase A	2 – 2 bolt bus bar mounting	35 (310)	M12 Hex (19 mm Hex Head)
	Load Bus B	Phase B	2 – 2 bolt bus bar mounting	35 (310)	M12 Hex (19 mm Hex Head)
	Load Bus C	Phase C	2 – 2 bolt bus bar mounting	35 (310)	M12 Hex (19 mm Hex Head)
Building and Load Ground	TBG	Ground	10 – #14–1/0	5.1 (45)	Slotted

The torque values listed for the M8 studs in [Table 13](#) and [Table 14](#) are the maximum allowable. Tightening further will risk breaking or twisting the stud.

[Figure 22](#), [Figure 23](#), [Figure 24](#), or [Figure 25](#) shows the location of the IAC-T power cable terminals.

Table 13. External Input Power Cable Terminations – Eaton 93PM 150 kW IAC-T 1+1 and 2+0 Parallel Configurations – with MIS and MBP

Terminal Function	Terminal	Function	Number and Size of Pressure Termination (AWG or kcmil)	Tightening Torque Nm (lb in)	Size Screw and Type
AC Input to MOB 1 from UPS 1	MOB1-1A	Phase A	2 – #2-500	42 (372)	5/16" Hex
	MOB1-3B	Phase B	2 – #2-500	42 (372)	5/16" Hex
	MOB1-5C	Phase C	2 – #2-500	42 (372)	5/16" Hex
	GND	Ground	2 – #14- 1/0	5.1 (45)	Slotted
AC Input to MOB 2 from UPS 2	MOB2-1A	Phase A	2 – #2-500	42 (372)	5/16" Hex
	MOB2-3B	Phase B	2 – #2-500	42 (372)	5/16" Hex
	MOB2-5C	Phase C	2 – #2-500	42 (372)	5/16" Hex
	TBG	Ground	2 – #14- 1/0	5.1 (45)	Slotted
AC Input to Maintenance Bypass (1+1 and 2+0)	MBP-1A	Phase A	1 – 2 stud bus bar mounting	12.2 (108)	M8 Stud with 13 mm Hex Nut
	MBP-3B	Phase B	1 – 2 stud bus bar mounting	12.2 (108)	M8 Stud with 13 mm Hex Nut
	MBP-5C	Phase C	1 – 2 stud bus bar mounting	12.2 (108)	M8 Stud with 13 mm Hex Nut
AC Output to Critical Load (1+1)	Load Bus A	Phase A	2 – #6-350	42 (375)	5/16" Hex
	Load Bus B	Phase B	2 – #6-350	42 (375)	5/16" Hex
	Load Bus C	Phase C	2 – #6-350	42 (375)	5/16" Hex
AC Output to Critical Load (2+0)	Load Bus A	Phase A	4 – #6-350	42 (375)	5/16" Hex
	Load Bus B	Phase B	4 – #6-350	42 (375)	5/16" Hex
	Load Bus C	Phase C	4 – #6-350	42 (375)	5/16" Hex
Building and Load Ground	TBG	Ground	10 – #14-1/0	5.1 (45)	Slotted

Table 14. External Input Power Cable Terminations – Eaton 93PM 200 kW IAC-T 1+1 and 2+0 Parallel Configurations – with MIS and MBP

Terminal Function	Terminal	Function	Number and Size of Pressure Termination (AWG or kcmil)	Tightening Torque Nm (lb in)	Size Screw and Type
AC Input to MOB 1 from UPS 1	MOB1–1A	Phase A	2 – #2–500	42 (372)	5/16" Hex
	MOB1–3B	Phase B	2 – #2–500	42 (372)	5/16" Hex
	MOB1–5C	Phase C	2 – #2–500	42 (372)	5/16" Hex
	GND	Ground	2 – #14– 1/0	5.1 (45)	Slotted
AC Input to MOB 2 from UPS 2	MOB2–1A	Phase A	2 – #2–500	42 (372)	5/16" Hex
	MOB2–3B	Phase B	2 – #2–500	42 (372)	5/16" Hex
	MOB2–5C	Phase C	2 – #2–500	42 (372)	5/16" Hex
	TBG	Ground	2 – #14– 1/0	5.1 (45)	Slotted
AC Input to Maintenance Bypass (1+1)	MBP–1A	Phase A	1 – 2 stud bus bar mounting	12.2 (108)	M8 Stud with 13 mm Hex Nut
	MBP–3B	Phase B	1 – 2 stud bus bar mounting	12.2 (108)	M8 Stud with 13 mm Hex Nut
	MBP–5C	Phase C	1 – 2 stud bus bar mounting	12.2 (108)	M8 Stud with 13 mm Hex Nut
AC Input to Maintenance Bypass (2+0)	Bypass Bus A	Phase A	2 – 2 bolt bus bar mounting	35 (310)	M12 Hex (19 mm Hex Head)
	Bypass Bus B	Phase B	2 – 2 bolt bus bar mounting	35 (310)	M12 Hex (19 mm Hex Head)
	Bypass Bus C	Phase C	2 – 2 bolt bus bar mounting	35 (310)	M12 Hex (19 mm Hex Head)
AC Output to Critical Load (1+1)	Load Bus A	Phase A	1 – 2 bolt bus bar mounting	35 (310)	M12 Hex (19 mm Hex Head)
	Load Bus B	Phase B	1 – 2 bolt bus bar mounting	35 (310)	M12 Hex (19 mm Hex Head)
	Load Bus C	Phase C	1 – 2 bolt bus bar mounting	35 (310)	M12 Hex (19 mm Hex Head)
AC Output to Critical Load (2+0)	Load Bus A	Phase A	2 – 2 bolt bus bar mounting	35 (310)	M12 Hex (19 mm Hex Head)
	Load Bus B	Phase B	2 – 2 bolt bus bar mounting	35 (310)	M12 Hex (19 mm Hex Head)
	Load Bus C	Phase C	2 – 2 bolt bus bar mounting	35 (310)	M12 Hex (19 mm Hex Head)
Building and Load Ground	TBG	Ground	10 – #14–1/0	5.1 (45)	Slotted

3.2.3 IAC-T Interface Wiring Preparation

Control wiring for features and options should be connected at the customer interface terminal blocks located inside the IAC-T.

 **WARNING**

Do not directly connect relay contacts to the mains related circuits. Reinforced insulation to the mains is required.

Read and understand the following notes while planning and performing the installation:

- Use Class 1 wiring methods (as defined by NEC Article 725) for interface wiring from 30V to 600V. The wire should be rated for 600V, 1A minimum. 12 AWG maximum wire size.
- Use Class 2 wiring methods (as defined by NEC Article 725) for interface wiring up to 30V. The wire should be rated for 24V, 1A minimum.
- Use twisted-pair wires for each input and return or common.
- All interface wiring and conduit is to be supplied by the customer.
- Interface wiring can be installed using the inter-cabinet wiring access pass-through or by routing wiring through conduit between cabinets.
- Install the interface wiring in separate conduit from the power wiring.

3.3 Inspecting and Unpacking the IAC-T

The cabinet is shipped bolted to a wooden pallet and covered with outer protective packaging material (see [Figure 8](#)).

 **NOTE** Startup and operational checks must be performed by an authorized Eaton Customer Service Engineer, or the warranty terms specified in [Chapter 9 Warranty](#) become void. This service is offered as part of the sales contract for the UPS. Contact an Eaton service representative in advance (a minimum two-week notice is required) to reserve a preferred startup date.

 **WARNING**

The IAC-T is heavy (see [Table 1](#)). If unpacking and unloading instructions are not closely followed, the cabinet may tip and cause serious injury.

1. Carefully inspect the outer packaging for evidence of damage during transit.
-

 **CAUTION**

Do not install a damaged cabinet. Report any damage to the carrier and contact an Eaton service representative immediately.

 **NOTE** For the following step, verify that the forklift or pallet jack is rated to handle the weight of the cabinet (see [Table 1](#) for cabinet weight).

2. Use a forklift or pallet jack to move the packaged cabinet to the installation site, or as close as possible, before unpacking. If possible, move the cabinet using the pallet. Insert the forklift or pallet jack forks between the supports on the bottom of the pallet. See [Figure 7](#) for the IAC-T center of gravity measurements.

**CAUTION**

Do not tilt the IAC-T more than 10° from vertical or the cabinet may tip over.

3. Set the pallet on a firm, level surface, allowing a minimum clearance of 3m (10 ft) on each side for removing the cabinet from the pallet.
 4. Remove the protective packaging material from the cabinet and recycle in a responsible manner. Retain the parts kit box packed at the top of the cabinet.
 5. Inspect the contents for any evidence of physical damage, and compare each item with the Bill of Lading. If damage has occurred or shortages are evident, contact an Eaton service representative immediately to determine the extent of the damage and its impact on further installation.
-

**NOTE**

While waiting for installation, protect the unpacked cabinet from moisture, dust, and other harmful contaminants. Failure to store and protect the IAC-T properly may void your warranty.

Figure 8. Eaton 93PM 150 kW IAC-T or 93PM 200 kW IAC-T as Shipped on Pallet

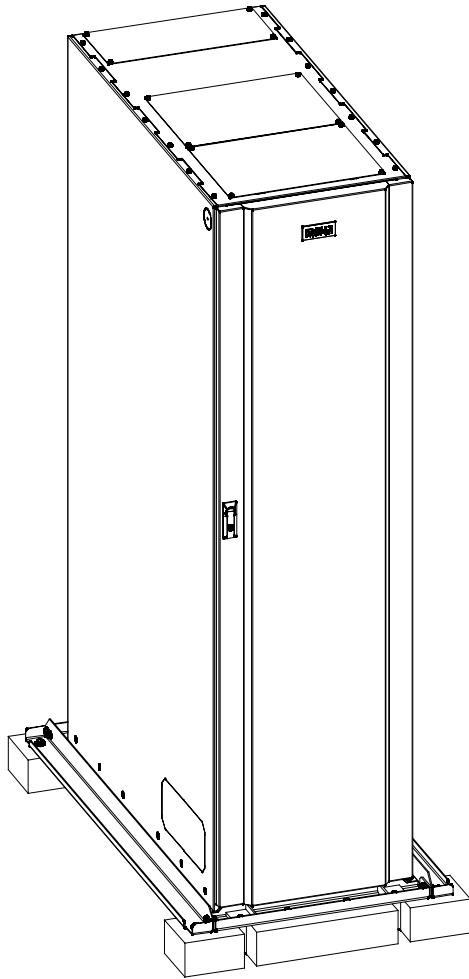

Chapter 4 Installation

4.1 Preliminary Installation Information

 **WARNING**

Installation should be performed only by qualified personnel knowledgeable of batteries and the required precautions.

Observe these precautions while installing the Integrated Accessory Cabinet-Tie (IAC-T):

- Remove watches, rings, or other metal objects.
- Use tools with insulated handles.
- Wear voltage rated gloves and electrical hazard footwear.
- Do not lay tools or metal parts on top of batteries or battery cabinets.
- Refer to the **Chapter 3 Installation Plan and Unpacking** for cabinet dimensions, equipment weight, wiring and terminal data, and installation notes.
- Do not tilt the cabinets more than 10° during installation.
- Remove conduit landing plates to add conduit landing holes as required.

Failure to follow these instructions may result in severe injury or death.

4.2 Unloading the IAC-T from the Pallet

The IAC-T is bolted to a pallet consisting of four metal angle supports secured to two wood supports.

 **WARNING**

The IAC-T is heavy (see [Table 1](#)). If unpacking and unloading instructions are not closely followed, the cabinet may tip and cause serious injury or death.

 **CAUTION**

- Do not tilt cabinet more than 10° from vertical.
 - Lift the cabinet only with a forklift or damage may occur.
 - Verify that the forklift is rated to handle the weight of the cabinet (see [Table 1](#) for cabinet weight).
-

To remove the pallet:

1. If not already accomplished, use a forklift or pallet jack to move the IAC-T to the installation area, or as close as possible, before unloading from the pallet. Insert the forklift or pallet jack forks between the supports on the bottom of the pallet (see [Figure 7](#) for the UPS cabinet center of gravity measurements).
2. Open the front door by lifting the latch from the bottom and turning to the right (counterclockwise) and swinging the door open.
3. Locate the four 1/2" jacking bolts from the parts kit and install them in the threaded holes in the front and rear supports as shown in [Figure 9](#). Place a floor protector from the parts kit underneath each jacking bolt, and screw the bolts down against them.

The floor protectors protect the floor from being marred by the jacking bolts.

Figure 9. Removing the Pallet Skids and Supports – Eaton 93PM 150 kW IAC-T and 93PM 200 kW IAC-T

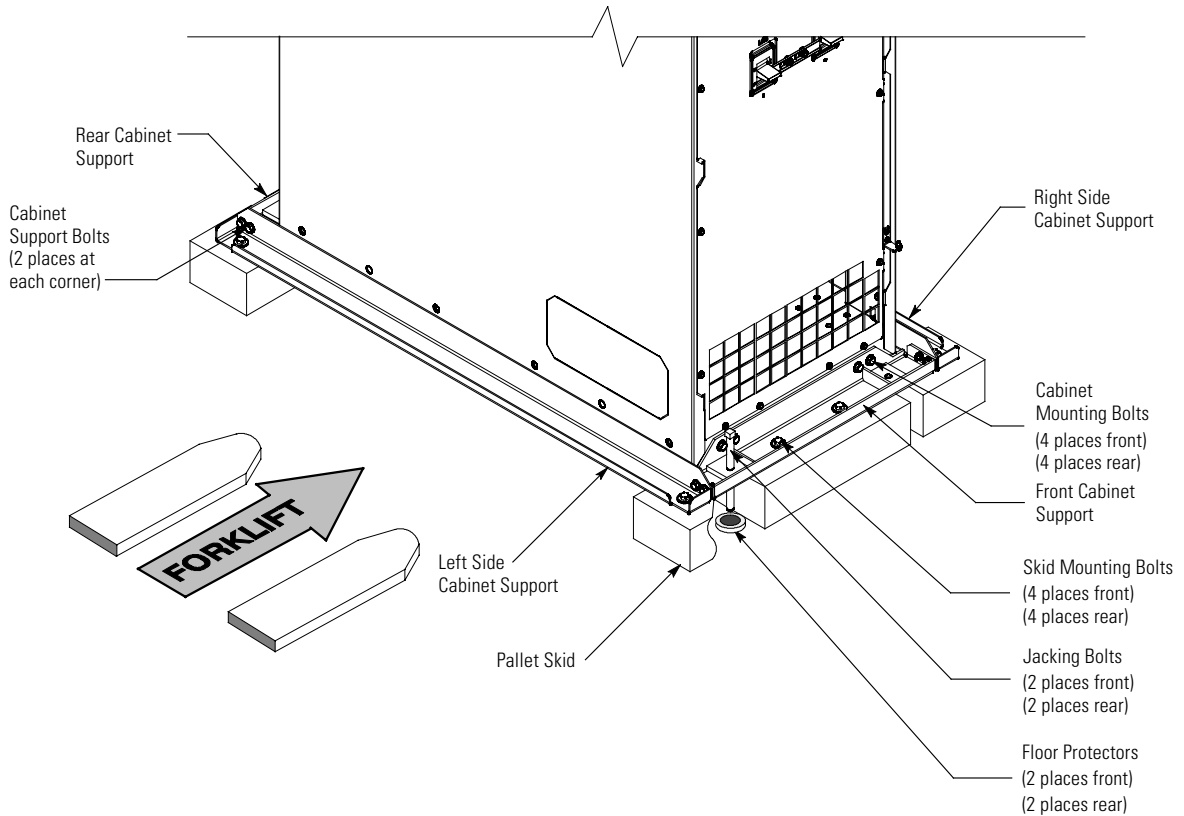

⚠ WARNING

Do not remove or loosen the cabinet mounting or cabinet support bolts until instructed.

4. Loosen, but do not remove, the skid mounting bolts holding the pallet skids to the front and rear supports, and to the left and right side supports (see [Figure 9](#)).
-

⚠ WARNING

RISK OF INSTABILITY. Turning the jacking bolts unevenly may cause the cabinet to become unbalanced. To prevent tipping the cabinet, raise and lower the jacking bolts evenly.

⚠ CAUTION

CABINET MAY TIP. Raise the IAC-T no more than 3 mm (1/8") above the floor (just enough to allow the removal of the pallet skids).

5. Turn each jacking bolt consecutively, two full turns, until the pallet skids clear the floor by approximately 3 mm (1/8").
6. Remove the hardware loosened in [Step 4](#).

7. Pull the pallet skids out from under the metal angle supports without disturbing the jacking bolts. Recycle the pallet skids and hardware in a responsible manner.

**CAUTION**

CABINET MAY FALL. Do not loosen the hardware attaching the front supports to the cabinet base. The cabinet must be lowered by the jacking bolts before the supports can be removed.

8. Carefully and evenly **lower the cabinet by turning each jacking bolt consecutively two full turns (maximum)** until the casters contact the floor and the cabinet is no longer supported by the jacking bolts.
9. After the IAC-T is resting on the floor, remove the jacking bolts and floor protectors. Recycle them in a responsible manner.
10. Remove the cabinet support bolts fastening the front, rear, and side cabinet supports together and remove the side supports (see [Figure 9](#)).
11. Remove the cabinet mounting bolts holding the front and rear supports to the cabinet base (see [Figure 9](#)).
12. Recycle the bolts along with the support brackets in a responsible manner.
13. Close the door and secure the latch.
14. If the leveling feet are not retracted, turn all four leveling feet until they are retracted as far into the cabinet as possible.
15. If line-up-and-match installation, remove the rectangular knockout on the bottom front side of the UPS and the IAC-T (see [Figure 10](#)).T

**NOTE**

In line-up-and-match installations, the IAC-T and UPS cabinets should be located as shown in [Figure 2](#) or [Figure 3](#).

**CAUTION**

To prevent tipping when rolling the cabinet and damage to the front door, push the cabinet from the rear whenever possible. Do not push the cabinet from the sides.

16. Roll the cabinet to the final installation location.
17. Level the IAC-T by lowering the leveling feet until the cabinet is level and is level with the adjacent cabinets.
18. Locate the top splice bracket shipped with the IAC-T.
19. Remove the screws along each adjacent cabinet top panel securing the top panels. Retain the hardware for later use.
20. Install the top splice bracket between the adjacent cabinet and secure the tie strap with retained hardware.

**NOTE**

Optional front and back floor mounting brackets are available to order for permanently mounting the IAC-T. Left and right side floor mounting brackets and mounting hardware to permanently mount the IAC-T are customer-supplied.

21. If permanently mounting the IAC-T using the left and right side floor mounting brackets, proceed to [Step 22](#); if using the front and rear floor mounting brackets, proceed to [Step 25](#); otherwise, proceed to [Step 28](#).
22. Using customer-supplied mounting bolts, install the customer-supplied floor mounting brackets to the left and right side of the IAC-T with the angle facing outward. See [Figure 6](#) for the floor mounting bracket dimensions.

23. Secure the cabinet to the floor with customer-supplied hardware.
24. Proceed to paragraph [4.3 Installing IAC-T External Power Wiring](#).
25. Locate the front and back floor mounting brackets from the optional floor mounting kit.
26. Using the cabinet mounting bolts from the kit, install the floor mounting brackets to the front and rear of the IAC-T with the angle facing outward.
27. Secure the cabinet to the floor with customer-supplied hardware.

i NOTE Black cover dots are provided, if side mounting bracket holes need to be covered for aesthetic reasons.

28. Locate the black cover dots from the parts kit and install over the left and right side bracket mounting holes.
29. Proceed to paragraph [4.3 Installing IAC-T External Power Wiring](#)

Figure 10. Line-Up-and-Match Wiring Access Locations

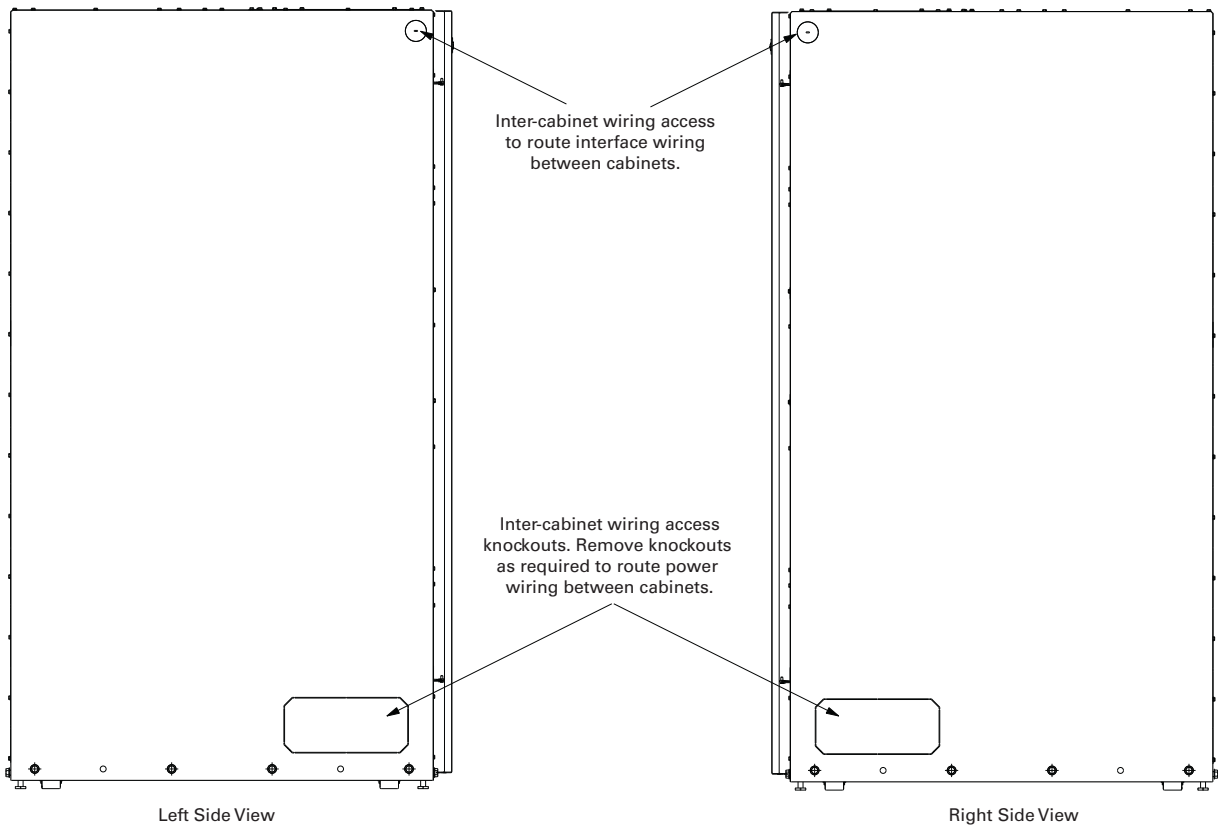

4.3 Installing IAC-T External Power Wiring

NOTE 1 Input power wiring is routed through the inside bottom of the IAC-T and UPS for line-up-and-match configurations or wiring can be installed using conduit between the cabinets for standalone installations. Output wiring is routed through the top or bottom of the cabinet using conduit.



NOTE 2 Remove the IAC-T conduit landing plates to drill or punch conduit holes, or remove knockouts in the conduit plates (see [Figure 12](#)).

NOTE 3 Refer to the applicable Eaton 93PM UPS Installation and Operation manual listed in paragraph [1.7 For More Information](#) for UPS installation procedures.

4.3.1 Two-Hole Barrel Lug Terminations to Bus Bar Installation

Paragraphs [4.3.2 IAC-T without a Maintenance Isolation Switch or Maintenance Bypass Breaker](#), [4.3.3 IAC-T with a Maintenance Isolation Switch](#), and [4.3.4 IAC-T with a Maintenance Isolation Switch and Maintenance Bypass Breaker](#) may require connecting input and output power wiring using 2-hole barrel lugs. See [Figure 11](#) for the hardware sequence when installing the lugs to the bus bars. Tighten the bolt to the torque value listed in [Table 9](#) through [Table 14](#).

Proceed to paragraph [4.3.2 IAC-T without a Maintenance Isolation Switch or Maintenance Bypass Breaker](#), [4.3.3 IAC-T with a Maintenance Isolation Switch](#), or [4.3.4 IAC-T with a Maintenance Isolation Switch and Maintenance Bypass Breaker](#).



NOTE Conical washers are special purpose washers that look similar to flat washers, except for a slight conical shape. When installing conical washers, the top of the dome should be next to the bolt head and the base of the washer should be against a flat surface such as a bus bar, flat washer, or large terminal.

Figure 11. Typical Bus Bar Barrel Lug Mounting – Hardware Assembly Sequence

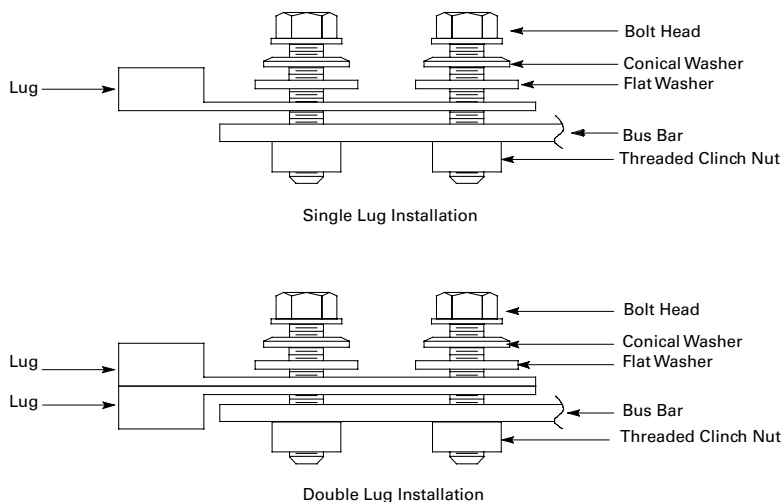

4.3.2 IAC-T without a Maintenance Isolation Switch or Maintenance Bypass Breaker

To install wiring to terminal connections

1. Verify the UPS system is turned off and all power sources are removed. Refer to the applicable Eaton 93PM UPS Installation and Operation manual, listed in paragraph [1.7 For More Information](#), for UPS operating procedures.
2. Open the front door by lifting the latch from the bottom and turning to the right (counterclockwise) and swing the door open.
3. Remove the screws securing the internal safety shield panel and remove the panel to gain access to the Module Output Breaker (MOB) input terminals and Load Bus output terminals. Retain the hardware for later use.
4. If wiring the IAC-T input power terminals using the inter-cabinet wiring access pass-through (line-up-and-match configurations), proceed to [Step 5](#); if wiring the IAC-T input power terminals using the bottom entry access, proceed to [Step 9](#); if wiring the IAC-T input power terminals using the top entry sidecar, proceed to [Step 13](#).
5. Route the IAC-T MOB input cables (phase A, B, and C and Ground) from the UPS cabinets through the bottom UPS and IAC-T inter-cabinet wiring access pass-through to the IAC-T MOB input terminals. See [Figure 10](#) for IAC-T wiring access information and [Figure 13](#) or [Figure 14](#) for IAC-T terminal locations. See paragraph [3.2.2 IAC-T Power Wiring Preparation](#), [Table 3](#) or [Table 4](#), and [Table 9](#) or [Table 10](#) for IAC-T wiring and termination requirements. Refer to the applicable Eaton 93PM UPS Installation and Operation manual, listed in paragraph [1.7 For More Information](#), for the UPS terminal locations and termination requirements.
6. Remove the top or bottom conduit plate (see [Figure 12](#)) from the IAC-T. Identify all output conduit requirements and mark their location. Drill and punch all conduit holes in the conduit plate prior to mounting on the IAC-T. Reinstall the conduit plate. Install conduit between the IAC-T and the critical load or Integrated Accessory Cabinet-Distribution (IAC-D). Pull the wiring through conduit into the wiring area.
7. Route the output cables (phase A, B, and C and Ground) from the IAC-T through the top or bottom of the cabinet to the critical load or IAC-D.
8. Proceed to [Step 16](#).

Figure 12. Top and Bottom Conduit Landing Wire Entry Location

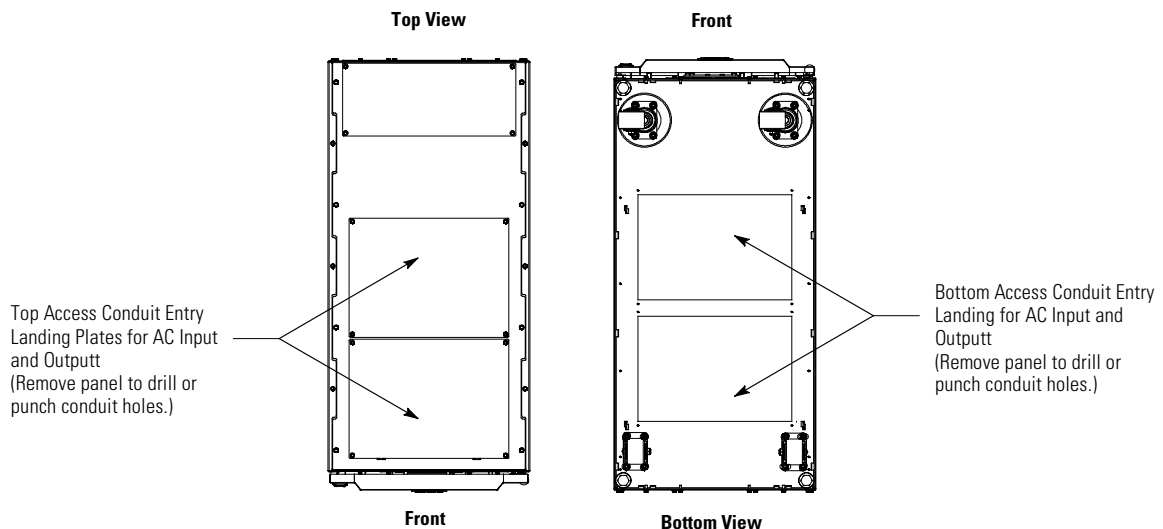

9. **Bottom Entry Wiring.** Remove the bottom conduit plate (see [Figure 12](#)) from the inside bottom of the IAC-T. Identify all conduit requirements (both input and output) and mark their location. Drill and punch all

conduit holes in the bottom conduit plate prior to mounting on the IAC-T. Install the conduit plate and install all conduit runs into the plate. Pull the wiring through conduit into the wiring area.

10. Route the IAC-T MOB input cables (phase A, B, and C and Ground) from the UPS cabinets through the bottom of the IAC-T to the IAC-T MOB input terminals. See [Figure 13](#) or [Figure 14](#) for IAC-T terminal locations. See paragraph [3.2.2 IAC-T Power Wiring Preparation](#), [Table 3](#) or [Table 4](#), and [Table 9](#) or [Table 10](#) for IAC-T wiring and termination requirements. Refer to the applicable Eaton 93PM UPS Installation and Operation manual, listed in paragraph [1.7 For More Information](#), for the UPS terminal locations and termination requirements.
11. Route the output cables (phase A, B, and C and Ground) from the IAC-T through the bottom of the cabinet to the critical load or IAC-D.
12. Proceed to [Step 16](#).
13. **Top Entry Wiring.** Remove the top conduit plate (see [Figure 12](#)) from the top of the IAC-T. Identify all conduit requirements (both input and output) and mark their location. Drill and punch all conduit holes in the top conduit plate prior to mounting on the sidecar. Install the conduit plate and install all conduit runs into the plate. Pull the wiring through the conduit into the wiring area.
14. Route the IAC-T MOB input cables (phase A, B, and C and Ground) from the UPS cabinets through the top of the IAC-T to the IAC-T MOB input terminals. See [Figure 13](#) or [Figure 14](#) for IAC-T terminal locations. See paragraph [3.2.2 IAC-T Power Wiring Preparation](#), [Table 3](#) or [Table 4](#), and [Table 9](#) or [Table 10](#) for IAC-T wiring and termination requirements. Refer to the applicable Eaton 93PM UPS Installation and Operation manual, listed in paragraph [1.7 For More Information](#), for the UPS terminal locations and termination requirements.
15. Route the output cables (phase A, B, and C and Ground) from the IAC-T through the top of the cabinet to the critical load or IAC-D.
16. Connect MOB phase A, B, and C and Ground power wiring to the corresponding MOB input terminals on the IAC-T.

For a detailed view of the IAC-T MOB input terminals, see [Figure 15](#).

17. Connect the MOB A, B, and C and Ground power wiring from the IAC-T to the corresponding UPS power terminals. Connect phase A, B, and C and Ground power wiring to the output terminals on the IAC-T.
18. Connect the phase A, B, and C, and Ground output power wiring from the IAC-T output terminals to the critical load or IAC-D.

For a detailed view of the IAC-T output terminals, see [Figure 16](#) or [Figure 17](#).

19. If wiring interface connections, proceed to paragraph [4.4 Installing IAC-T Interface Connections](#); otherwise, proceed to [Step 20](#).
20. Reinstall the internal safety shield panel removed in [Step 3](#).
21. Close the outside door and secure the latch.
22. After the IAC-T is installed and wired, return to the applicable Eaton 93PM UPS Installation and Operation manual listed in paragraph [1.7 For More Information](#) to complete the UPS wiring.

Figure 13. 93PM IAC-T Power Terminal Locations – 150 kW (1+1 and 2+0) with No MIS or MBP

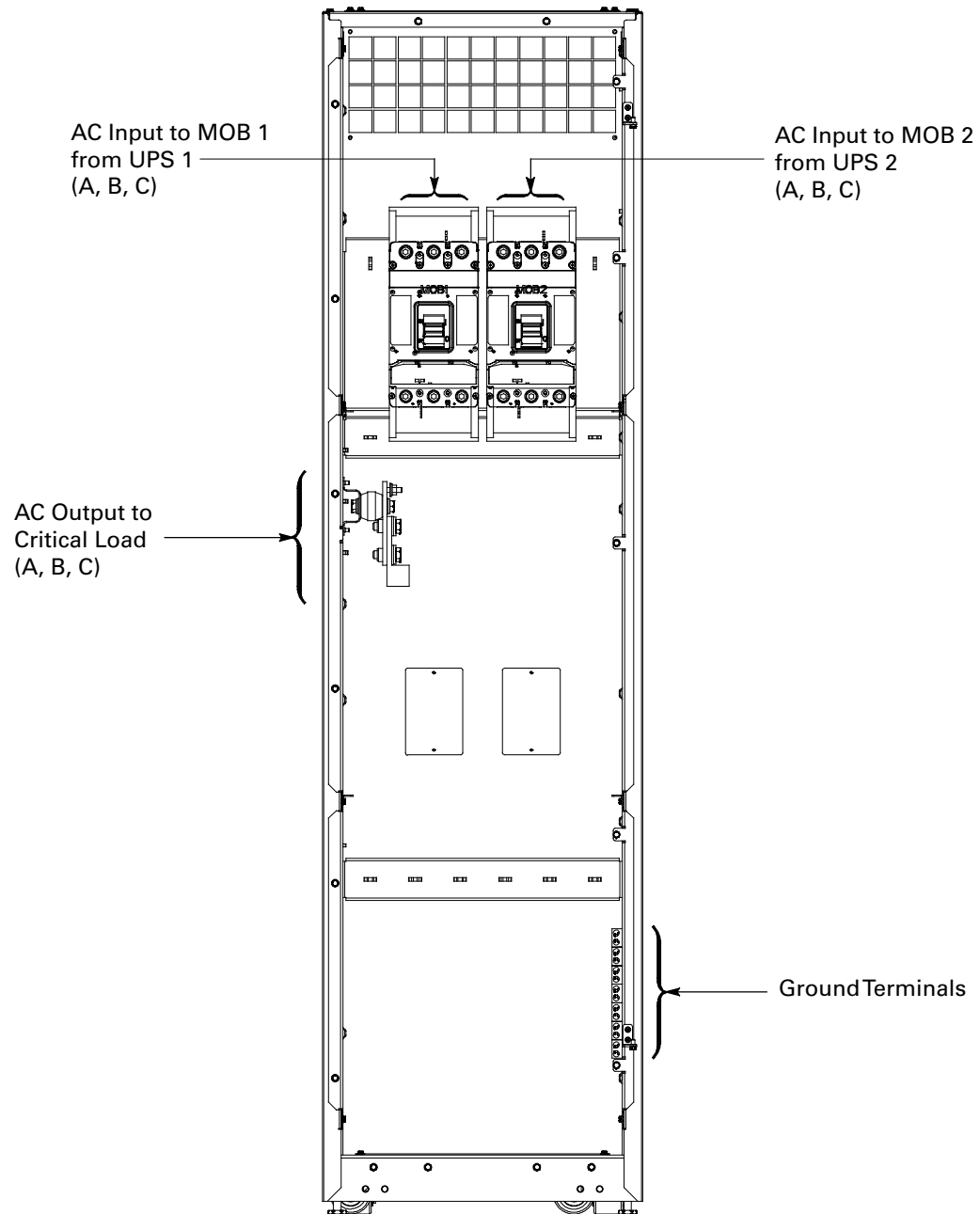

Figure 14. 93PM IAC-T Power Terminal Locations – 200 kW (1+1 and 2+0) with No MIS or MBP

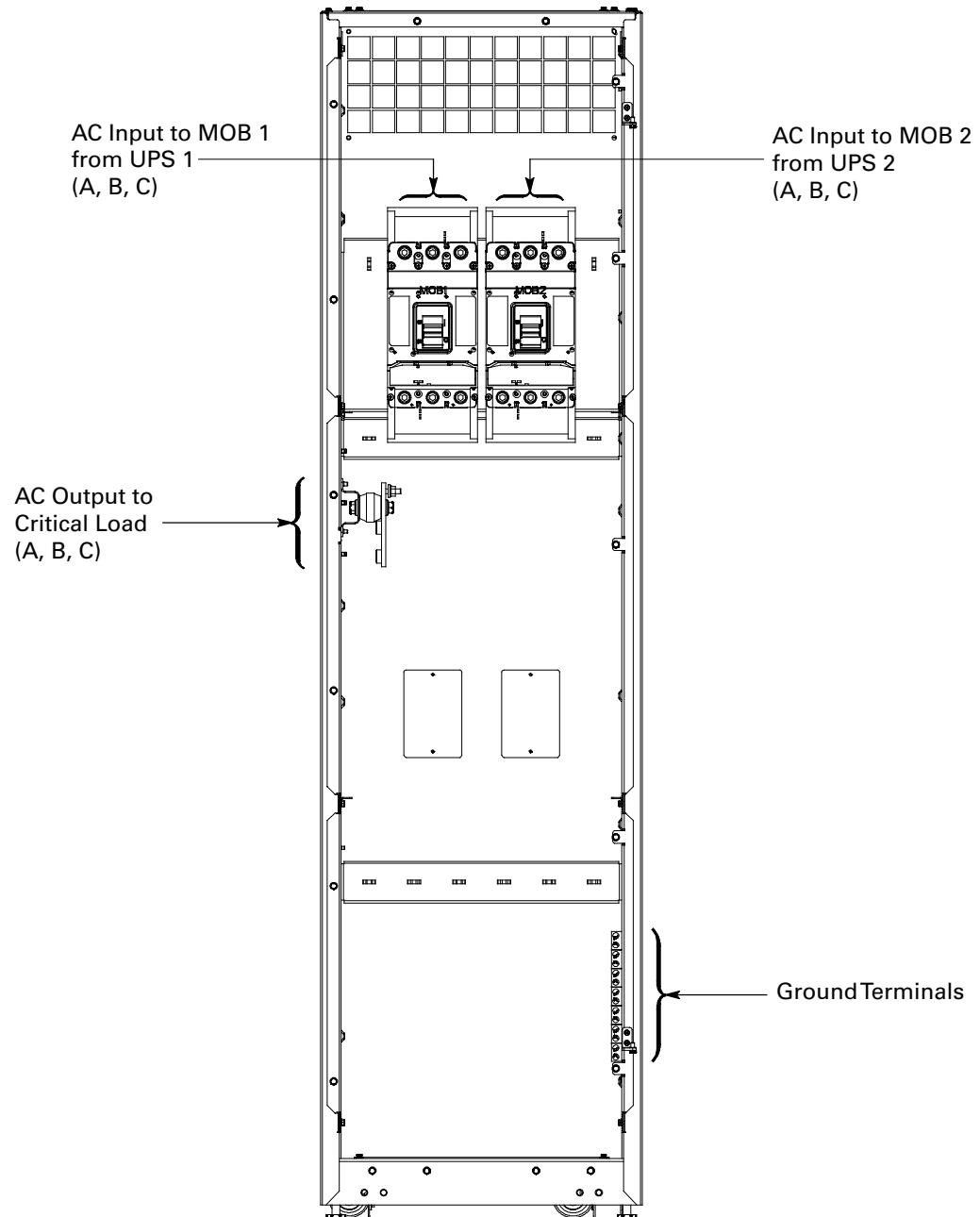

Figure 15. 93PM IAC-T Power Input Terminal Detail – 150 kW (1+1 and 2+0) and 200 kW (1+1 and 2+0) MOB

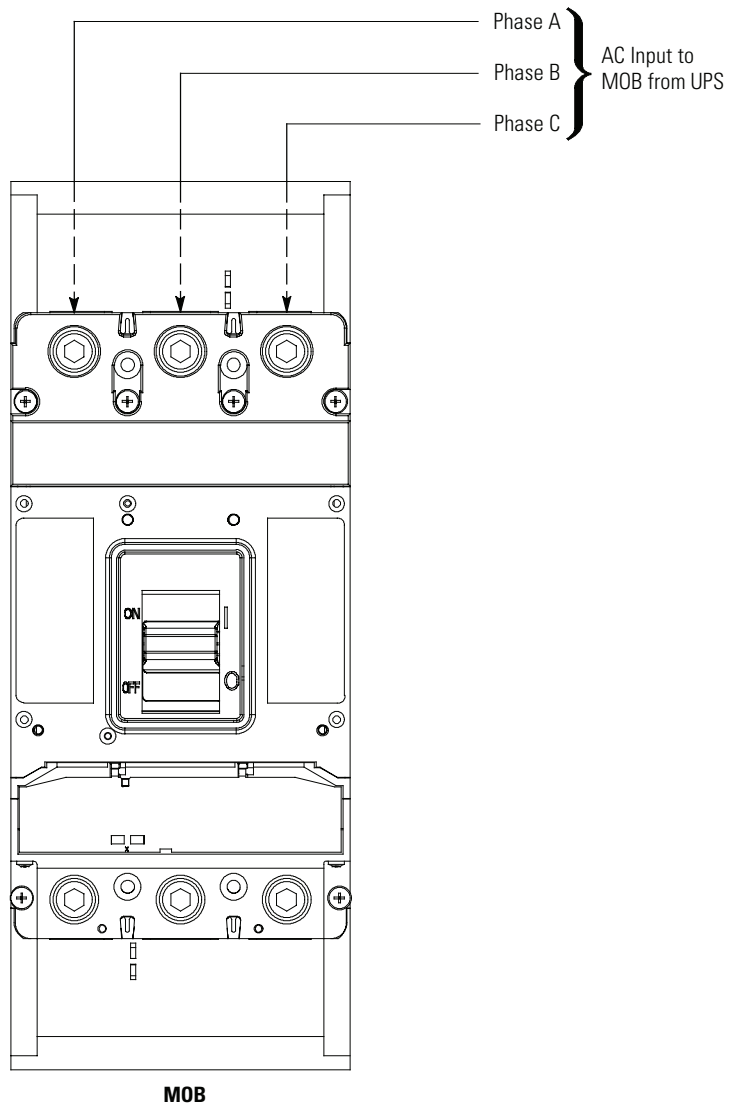

Figure 16. 93PM IAC-T Power Output Terminal Detail – 150 kW (1+1 and 2+0) MOB Load Bus

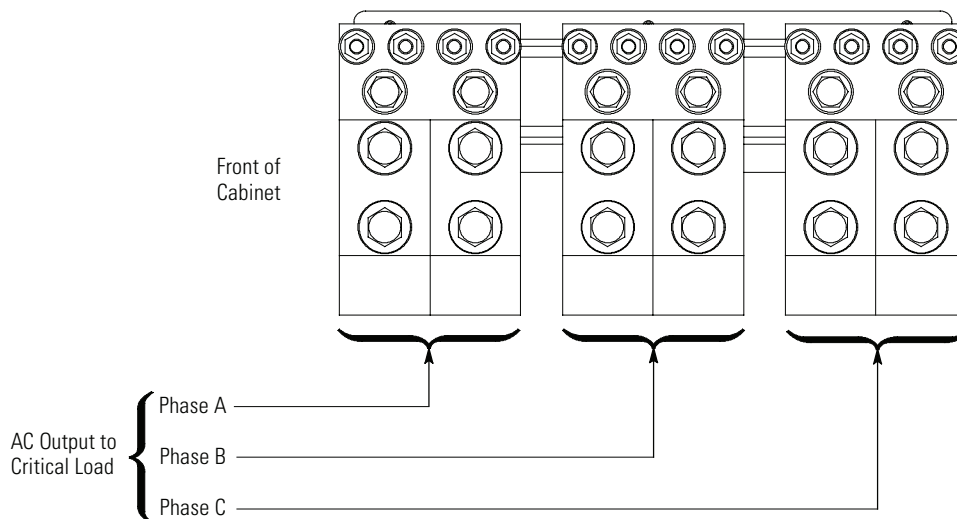
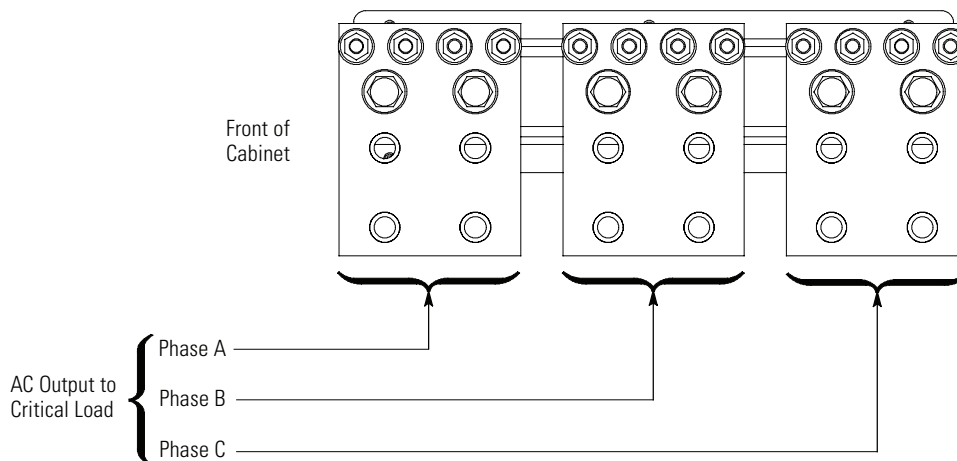

Figure 17. 93PM IAC-T Power Output Terminal Detail – 200 kW (1+1 and 2+0) MOB Load Bus



4.3.3 IAC-T with a Maintenance Isolation Switch

To install wiring to terminal connections

1. Verify the UPS system is turned off and all power sources are removed. Refer to the applicable Eaton 93PM UPS Installation and Operation manual, listed in paragraph [1.7 For More Information](#), for UPS operating procedures.
2. Open the front door by lifting the latch from the bottom and turning to the right (counterclockwise) and swing the door open.
3. Remove the screws securing the internal safety shield panel and remove the panel to gain access to the Module Output Breaker (MOB) input terminals and the Maintenance Isolation Switch (MIS) output terminals. Retain the hardware for later use.
4. If wiring the IAC-T input power terminals using the inter-cabinet wiring access pass-through (line-up-and-match configurations), proceed to [Step 5](#); if wiring the IAC-T input power terminals using the bottom entry

- access, proceed to [Step 9](#); if wiring the IAC-T input power terminals using the top entry sidecar, proceed to [Step 13](#).
5. **Pass-through Wiring.** Route the IAC-T MOB input cables (phase A, B, and C and Ground) from the UPS cabinets through the bottom UPS and IAC-T inter-cabinet wiring access pass-through to the IAC-T MOB input terminals. See [Figure 10](#) for IAC-T wiring access information and [Figure 18](#) or [Figure 19](#) for IAC-T terminal locations. See paragraph [3.2.2 IAC-T Power Wiring Preparation](#), [Table 5](#) or [Table 6](#), and [Table 11](#) or [Table 12](#) for IAC-T wiring and termination requirements. Refer to the applicable Eaton 93PM UPS Installation and Operation manual, listed in paragraph [1.7 For More Information](#), for the UPS terminal locations and termination requirements.
 6. Remove the top or bottom conduit plate (see [Figure 12](#)) from the IAC-T. Identify all output conduit requirements and mark their location. Drill and punch all conduit holes in the conduit plate prior to mounting on the IAC-T. Reinstall the conduit plate. Install conduit between the IAC-T and the critical load or Integrated Accessory Cabinet-Distribution (IAC-D). Pull the wiring through conduit into the wiring area.
 7. Route the output cables (phase A, B, and C and Ground) from the IAC-T through the top or bottom of the cabinet to the critical load or IAC-D.
 8. Proceed to [Step 16](#).
 9. **Bottom Entry Wiring.** Remove the bottom conduit plate (see [Figure 12](#)) from the inside bottom of the IAC-T. Identify all conduit requirements (both input and output) and mark their location. Drill and punch all conduit holes in the bottom conduit plate prior to mounting on the IAC-T. Install the conduit plate and install all conduit runs into the plate. Pull the wiring through conduit into the wiring area.
 10. Route the IAC-T MOB input cables (phase A, B, and C and Ground) from the UPS cabinets through the bottom of the IAC-T to the IAC-T MOB input terminals. See [Figure 18](#) or [Figure 19](#) for IAC-T terminal locations.
 11. Route the output cables (phase A, B, and C and Ground) from the IAC-T through the bottom of the cabinet to the critical load or IAC-D.
 12. Proceed to [Step 16](#).
 13. **Top Entry Wiring.** Remove the top conduit plate (see [Figure 12](#)) from the top of the IAC-T. Identify all conduit requirements (both input and output) and mark their location. Drill and punch all conduit holes in the top conduit plate prior to mounting on the sidecar. Install the conduit plate and install all conduit runs into the plate. Pull the wiring through the conduit into the wiring area.
 14. Route the IAC-T MOB input cables (phase A, B, and C and Ground) from the UPS cabinets through the top of the IAC-T to the IAC-T MOB input terminals.
 15. Route the output cables (phase A, B, and C and Ground) from the IAC-T through the top of the cabinet to the critical load or IAC-D.
 16. Connect MOB phase A, B, and C and Ground power wiring to the corresponding MOB input terminals on the IAC-T.
For a detailed view of the IAC-T MOB input terminals, see [Figure 15](#).
 17. Connect the MOB A, B, and C and Ground power wiring from the IAC-T to the corresponding UPS power terminals. Connect phase A, B, and C and Ground power wiring to the output terminals on the IAC-T.
 18. Connect the phase A, B, and C, and Ground output power wiring from the IAC-T output terminals to the critical load or IAC-D.
For a detailed view of the IAC-T output terminals, see [Figure 20](#) or [Figure 21](#).
 19. If wiring interface connections, proceed to paragraph [4.4 Installing IAC-T Interface Connections](#); otherwise, proceed to [Step 20](#).
 20. Reinstall the internal safety shield panel removed in [Step 3](#).
 21. Close the outside door and secure the latch.

22. After the IAC-T is installed and wired, return to the applicable Eaton 93PM UPS Installation and Operation manual listed in paragraph [1.7 For More Information](#) to complete the UPS wiring.

Figure 18. 93PM IAC-T Power Terminal Locations – 150 kW (1+1 and 2+0) and 200 kW (1+1) with MIS

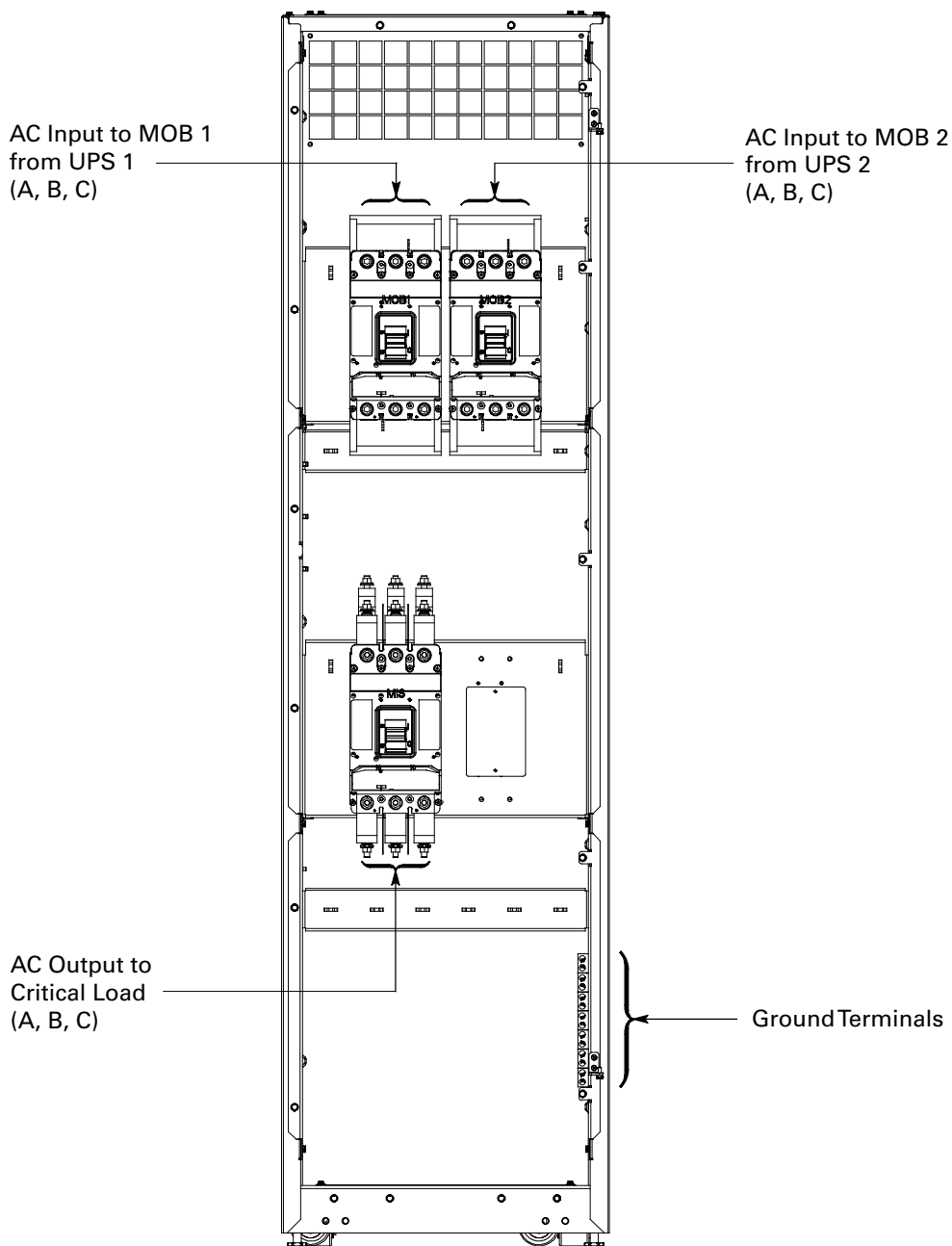

Figure 19. 93PM IAC-T Power Terminal Locations – 200 kW (2+0) with MIS

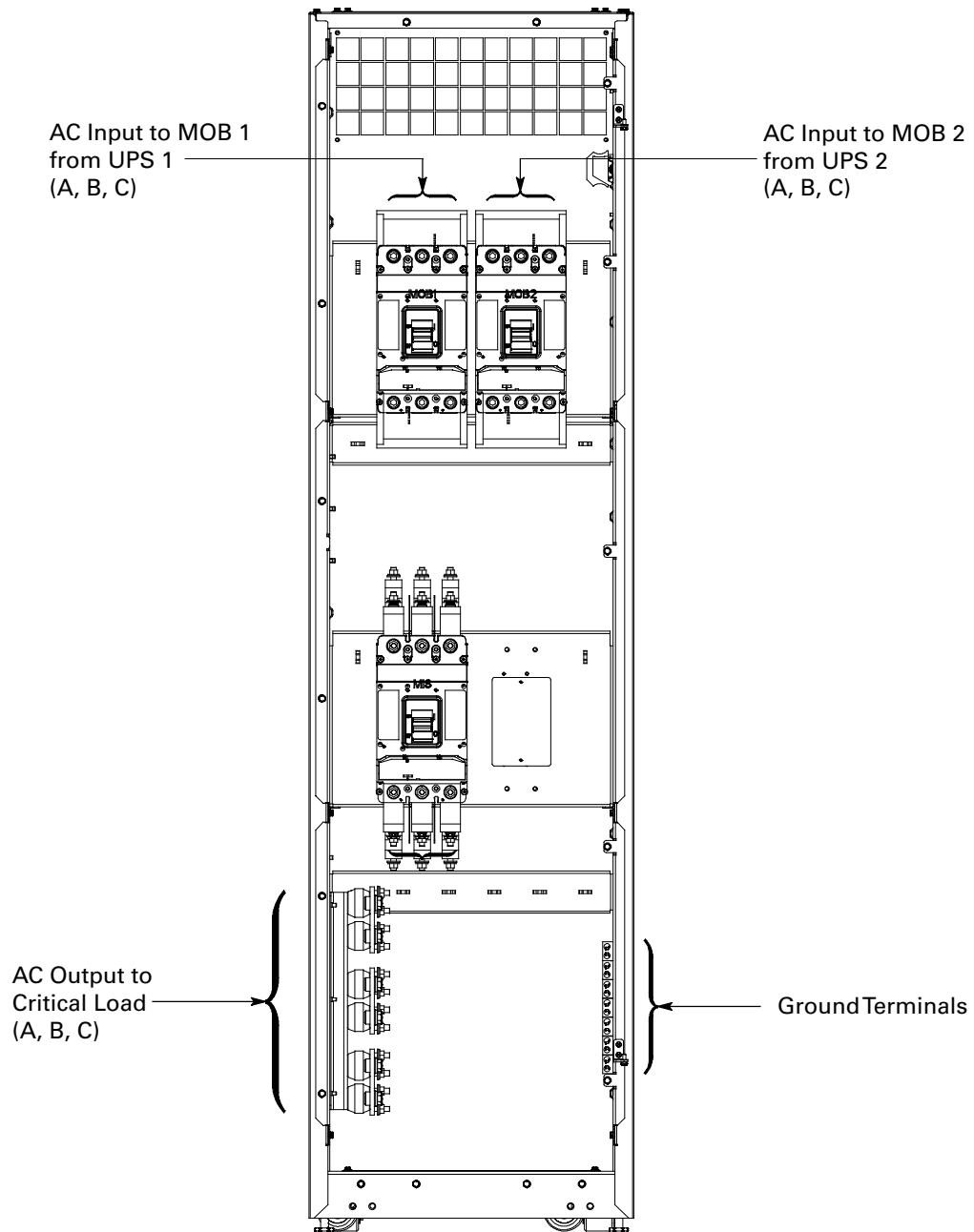

Figure 20. 93PM IAC-T Power Output Terminal Detail – 150 kW (1+1 and 2+0) and 200 kW (1+1) with MIS

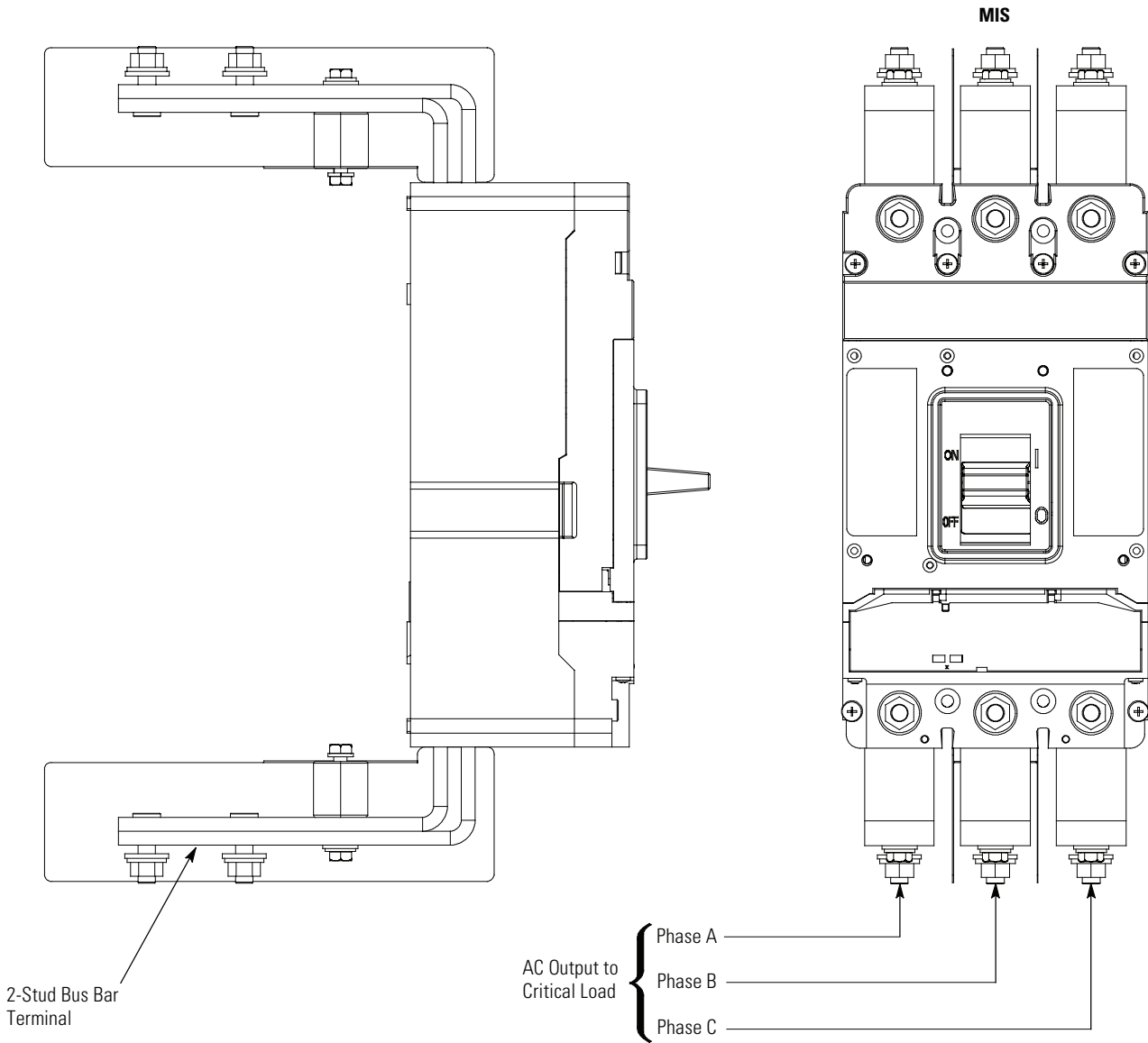
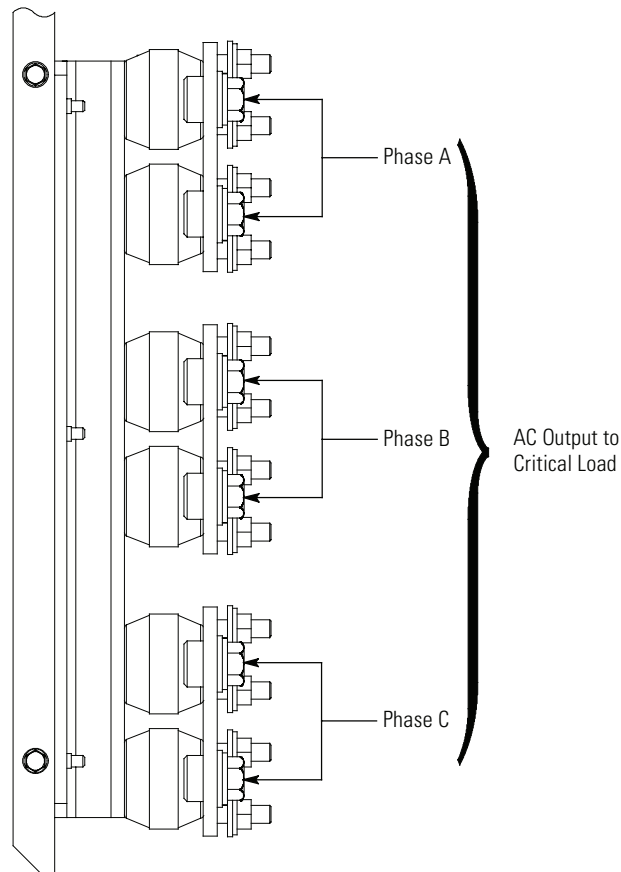

Figure 21. 93PM IAC-T Power Output Terminal Detail – 200 kW (2+0) with MIS and 200 kW (2+0) with MIS and MBP



4.3.4 IAC-T with a Maintenance Isolation Switch and Maintenance Bypass Breaker

To install wiring to terminal connections:

1. Verify the UPS system is turned off and all power sources are removed. Refer to the applicable Eaton 93PM UPS Installation and Operation manual, listed in paragraph [1.7 For More Information](#), for UPS operating procedures.
2. Open the front door by lifting the latch from the bottom and turning to the right (counterclockwise) and swing the door open.
3. Remove the screws securing the internal safety shield panel and remove the panel to gain access to the Module Output Breaker (MOB) input terminals, the Maintenance Bypass Breaker (MBP) input terminals, and the Load Bus output terminals. Retain the hardware for later use.
4. If wiring the IAC-T input power terminals using the inter-cabinet wiring access pass-through (line-up-and-match configurations), proceed to [Step 5](#); if wiring the IAC-T input power terminals using the bottom entry access, proceed to [Step 10](#); if wiring the IAC-T input power terminals using the top entry sidecar, proceed to [Step 15](#).
5. **Pass-through Wiring.** Route the IAC-T MOB input cables (phase A, B, and C and Ground) from the UPS cabinets through the bottom UPS and IAC-T inter-cabinet wiring access pass-through to the IAC-T MOB input terminals. See [Figure 10](#) for IAC-T wiring access information and [Figure 22](#), [Figure 23](#), [Figure 24](#), or [Figure 25](#) for IAC-T terminal locations. See paragraph [3.2.2 IAC-T Power Wiring Preparation](#), [Table 7](#) or [Table 8](#), and [Table 13](#) or [Table 14](#) for IAC-T wiring and termination requirements. Refer to the applicable

Eaton 93PM UPS Installation and Operation manual, listed in paragraph [1.7 For More Information](#), for the UPS terminal locations and termination requirements.

6. Remove the top or bottom conduit plate (see [Figure 12](#)) from the IAC-T. Identify all input and output conduit requirements and mark their location. Drill and punch all conduit holes in the conduit plate prior to mounting on the IAC-T. Reinstall the conduit plate. Install conduit between the IAC-T and the critical load or Integrated Accessory Cabinet-Distribution (IAC-D). Pull the wiring through conduit into the wiring area.
7. Route the output cables (phase A, B, and C and Ground) from the IAC-T through the top or bottom of the cabinet to the critical load or IAC-D.
8. Route the maintenance bypass input (phase A, B, and C, and Ground) through the top or bottom of the IAC-T to the MBP terminals.
9. Proceed to [Step 19](#).
10. **Bottom Entry Wiring.** Remove the bottom conduit plate (see [Figure 12](#)) from the inside bottom of the IAC-T. Identify all conduit requirements (both input and output) and mark their location. Drill and punch all conduit holes in the bottom conduit plate prior to mounting on the IAC-T. Install the conduit plate and install all conduit runs into the plate. Pull the wiring through conduit into the wiring area.
11. Route the IAC-T MOB input cables (phase A, B, and C and Ground) from the UPS cabinets through the bottom of the IAC-T to the IAC-T MOB input terminals.
12. Route the output cables (phase A, B, and C and Ground) from the IAC-T through the bottom of the cabinet to the critical load or IAC-D.
13. Route the maintenance bypass input (phase A, B, and C, and Ground) through the bottom of the IAC-T to the MBP terminals. S
14. Proceed to [Step 19](#).
15. **Top Entry Wiring.** Remove the top conduit plate (see [Figure 12](#)) from the top of the IAC-T. Identify all conduit requirements (both input and output) and mark their location. Drill and punch all conduit holes in the top conduit plate prior to mounting on the sidecar. Install the conduit plate and install all conduit runs into the plate. Pull the wiring through the conduit into the wiring area.
16. Route the IAC-T MOB input cables (phase A, B, and C and Ground) from the UPS cabinets through the top of the IAC-T to the IAC-T MOB input terminals.
17. Route the output cables (phase A, B, and C and Ground) from the IAC-T through the top of the cabinet to the critical load or IAC-D.
18. Route the maintenance bypass input (phase A, B, and C, and Ground) through the top of the IAC-T to the MBP terminals.
19. Connect MOB phase A, B, and C and Ground power wiring to the corresponding MOB input terminals on the IAC-T.

For a detailed view of the IAC-T MOB input terminals, see [Figure 15](#).
20. Connect the MOB A, B, and C and Ground power wiring from the IAC-T to the corresponding UPS power terminals. Connect phase A, B, and C and Ground power wiring to the output terminals on the IAC-T.
21. Connect phase A, B, and C, and Ground bypass input power wiring from the utility source to the IAC-T maintenance bypass input terminals.

For a detailed view of the IAC-T MBP input terminals, see [Figure 26](#) or [Figure 30](#).
22. Connect the phase A, B, and C, and Ground output power wiring from the IAC-T output terminals to the critical load or IAC-D.

For a detailed view of the IAC-T output terminals, see [Figure 27](#), [Figure 28](#), or [Figure 29](#).

Installation

23. If wiring interface connections, proceed to paragraph [4.4 Installing IAC-T Interface Connections](#); otherwise, proceed to [Step 24](#).
24. Reinstall the internal safety shield panel removed in [Step 3](#).
25. Close the outside door and secure the latch.
26. After the IAC-T is installed and wired, return to the applicable Eaton 93PM UPS Installation and Operation manual listed in paragraph [1.7 For More Information](#) to complete the UPS wiring.

Figure 22. 93PM IAC-T Power Terminal Locations – 150 kW (1+1) with MIS and MBP

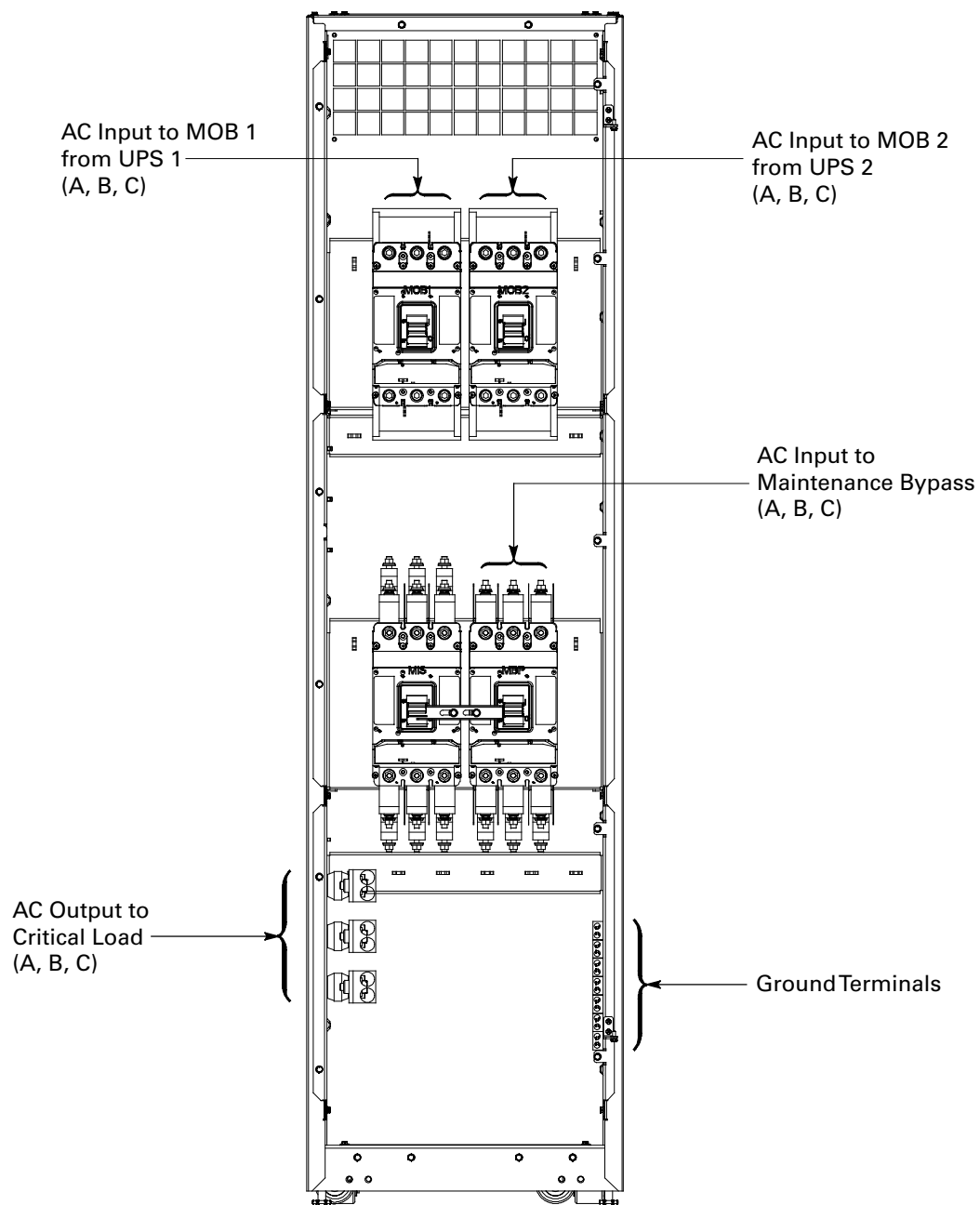

Figure 23. 93PM IAC-T Power Terminal Locations – 150 kW (2+0) with MIS and MBP

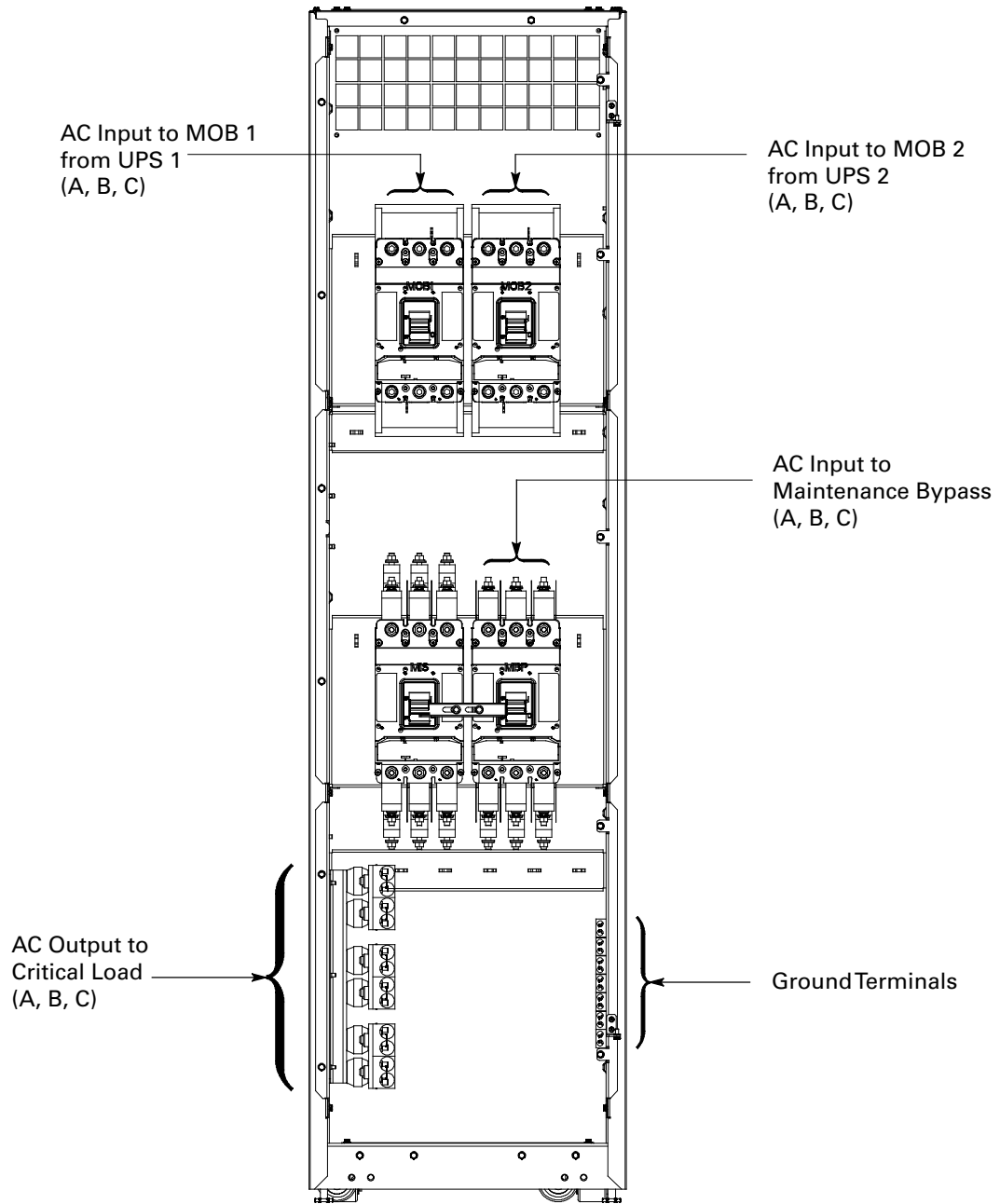

Figure 24. 93PM IAC-T Power Terminal Locations – 200 kW (1+1) with MIS and MBP

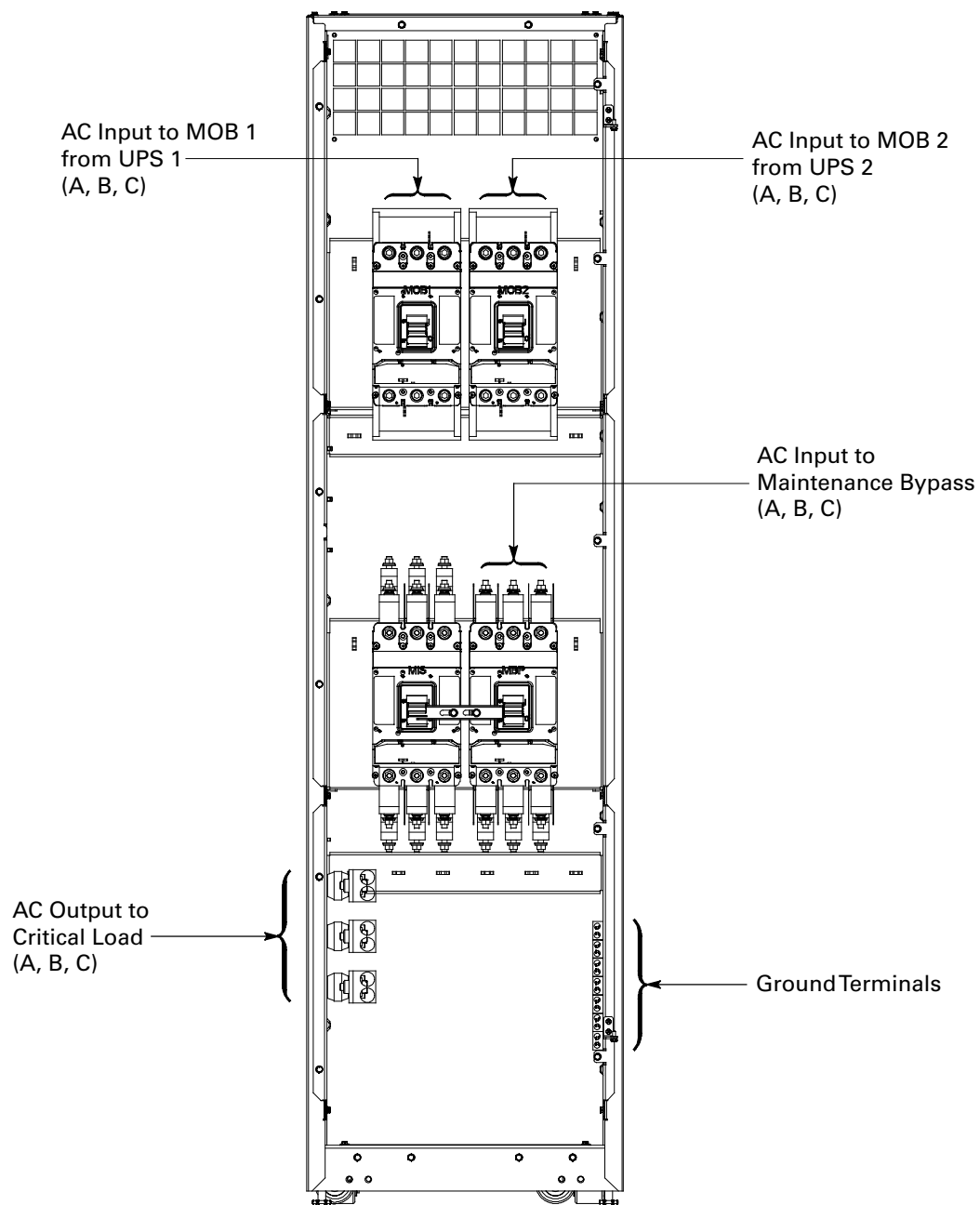

Figure 25. 93PM IAC-T Power Terminal Locations – 200 kW (2+0) with MIS and MBP

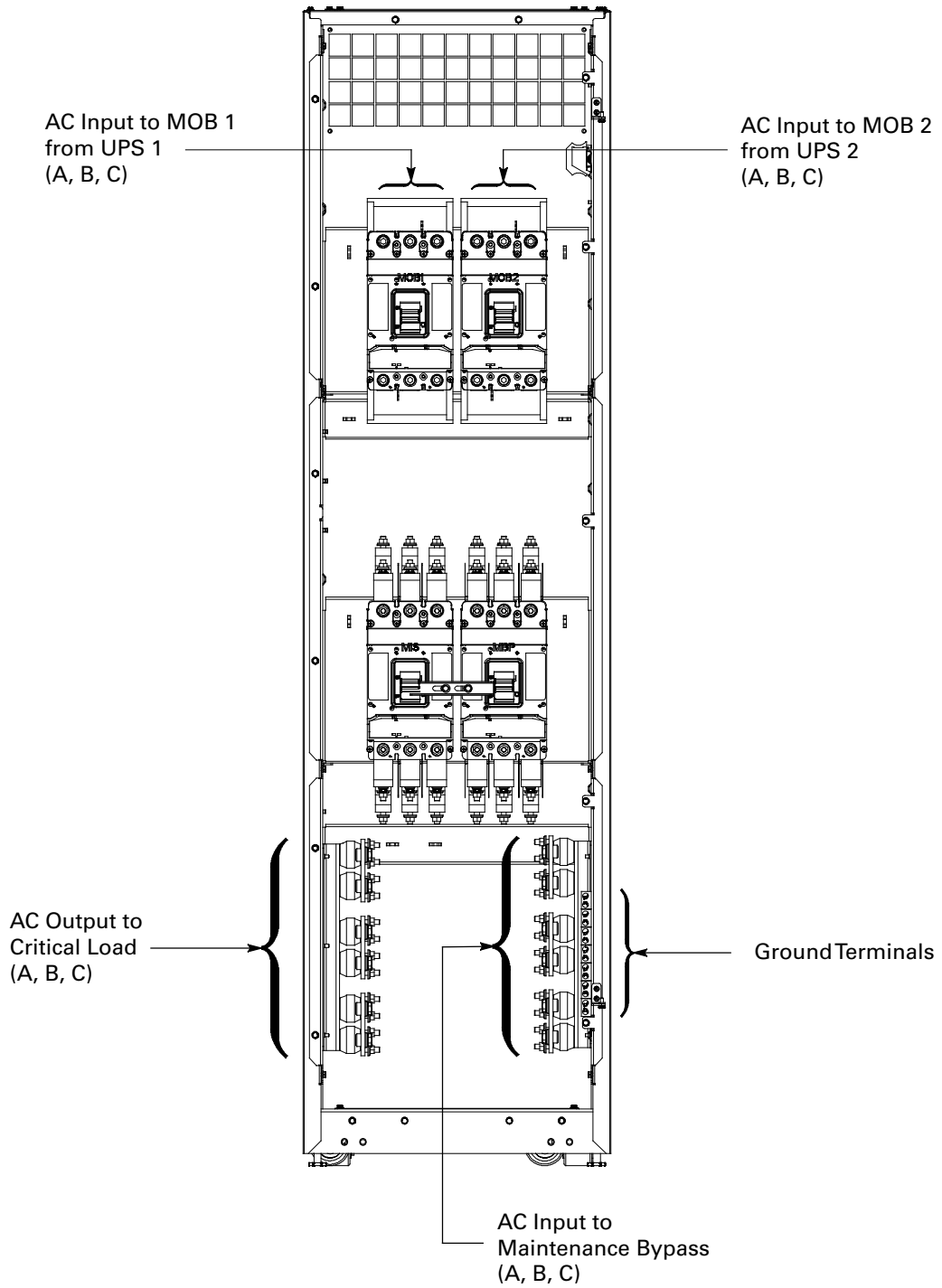

Figure 26. 93PM IAC-T Power Input Terminal Detail – 150 kW (1+1 and 2+0) and 200 kW (1+1) with MIS and MBP

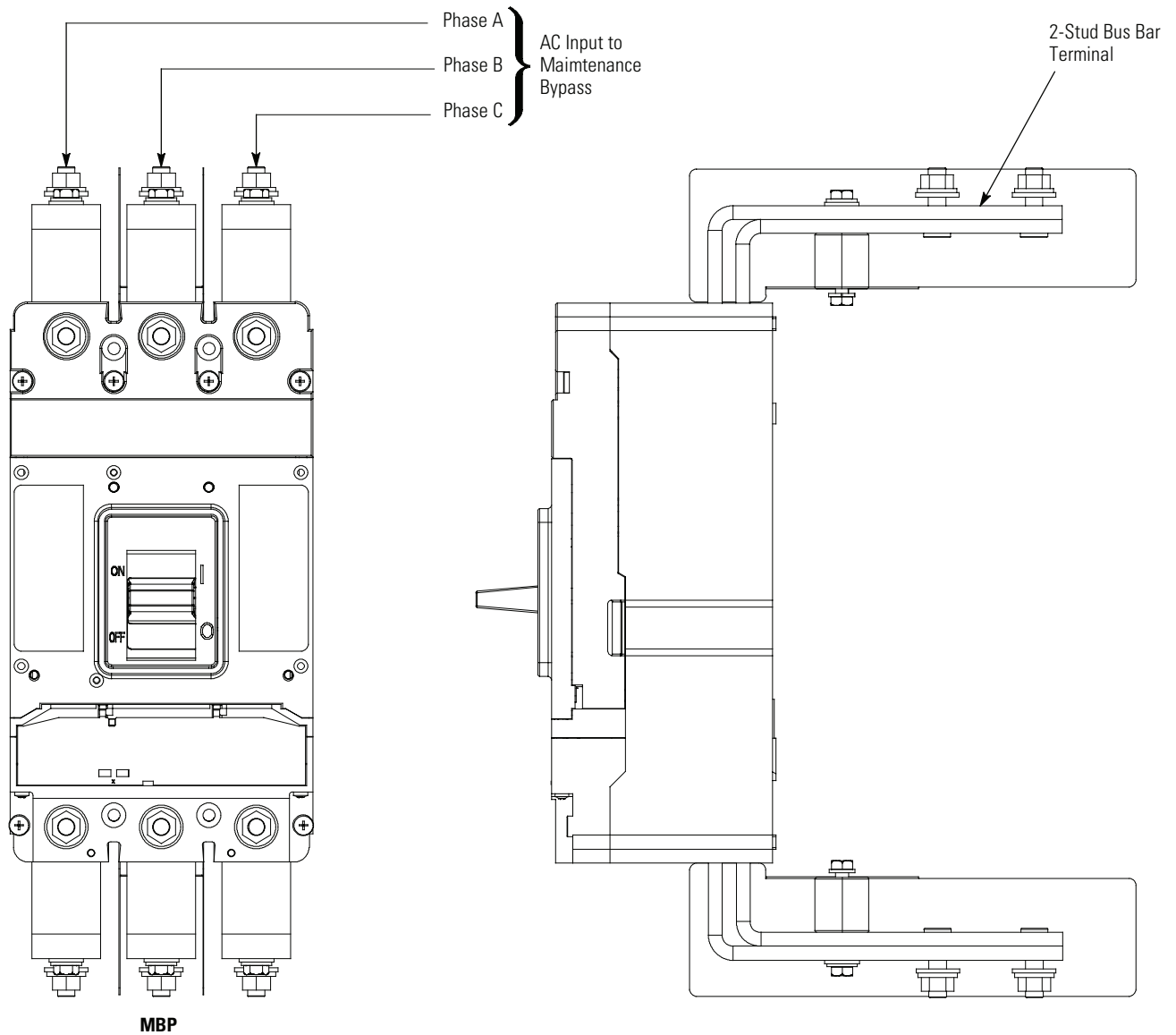

Figure 27. 93PM IAC-T Power Output Terminal Detail – 150 kW (1+1) with MIS and MBP

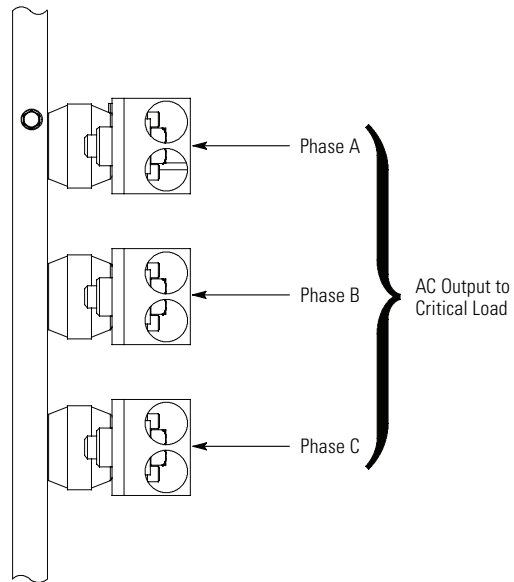

Figure 28. 93PM IAC-T Power Output Terminal Detail – 150 kW (2+0) with MIS and MBP

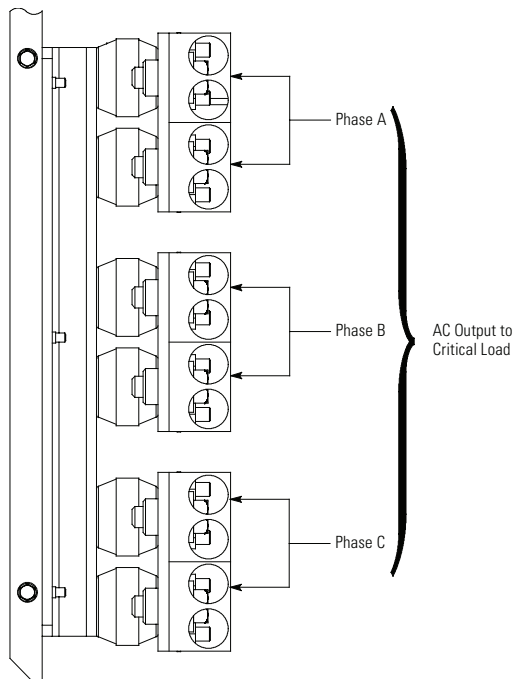

Figure 29. 93PM IAC-T Power Output Terminal Detail – 200 kW (1+1) with MIS and MBP

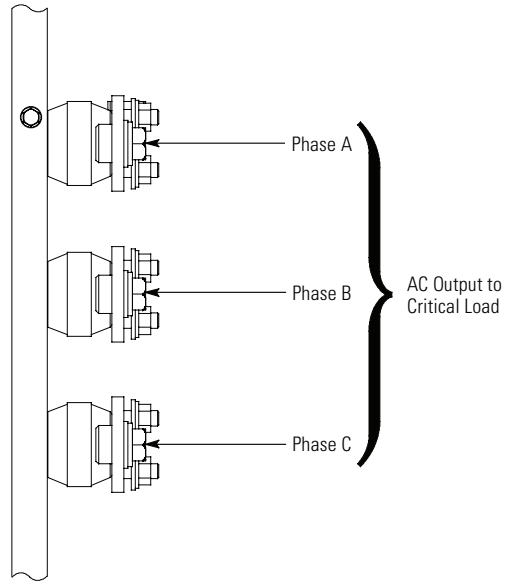
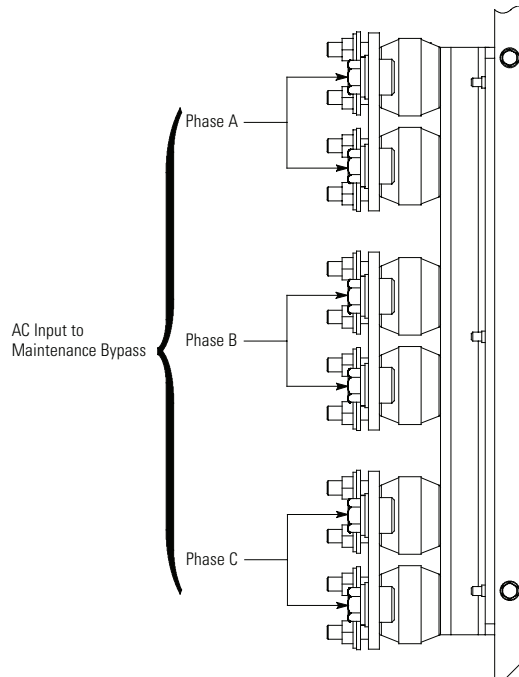

Figure 30. 93PM IAC-T Power Input Terminal Detail – 200 kW (2+0) with MIS and MBP



4.4 Installing IAC-T Interface Connections

-
- NOTE 1** IAC-T MOB, pull chain, and MBP auxiliary contact control interface wiring can be installed using the inter-cabinet wiring access pass through (line-up-and-match configurations) or conduit between cabinets (standalone configurations).
- NOTE 2** If using conduit, install the control wiring in separate conduit from the power wiring.
- NOTE 3** Remove the IAC-T conduit landing plates to drill or punch conduit holes, or remove knockouts in the conduit plate (see [Figure 12](#)).
- NOTE 4** Any pair of unused UPS building alarm terminals may be used for the MOB and interface connections.
-

To install wiring:

1. Verify the UPS system is turned off and all power sources are removed. Refer to the applicable Eaton 93PM UPS Installation and Operation manual listed in paragraph [1.7 For More Information](#), for UPS operating procedures.
2. If not already opened, open the front door by lifting the latch from the bottom and turning to the right (counterclockwise) and swing the door open.
3. If not already removed, remove the screws securing the internal safety shield panel and remove the panel to gain access to the interface terminals. Retain the hardware for later use.
4. If wiring the IAC-T interface terminals using the inter-cabinet wiring access pass-through (line-up-and-match configurations), proceed to [Step 5](#); if wiring the IAC-T input power terminals using the bottom entry access, proceed to [Step 7](#); if wiring the IAC-T input power terminals using the top entry sidecar, proceed to [Step 9](#).
5. **Pass-through Wiring.** Route the MOB, pull chain, and MBP (if installed) control wiring between the IAC-T interface terminals and the UPS cabinet interface terminals using the inter-cabinet wiring access pass-through. See [Figure 10](#) for wiring access information, and [Figure 31](#) for IAC-T interface terminal locations. Refer to the applicable Eaton 93PM UPS Installation and Operation manual, listed in paragraph [1.7 For More Information](#), for the UPS wiring access information, terminal locations, and termination requirements.
6. Proceed to [Step 10](#).
7. **Bottom Entry Wiring.** Route the MOB, pull chain, and MBP (if installed) control wiring between the IAC-T interface terminals and the UPS cabinet interface terminals using the bottom entry conduit landing plates on the IAC-T and the UPS. See [Figure 12](#) for wiring access information, and [Figure 31](#) for IAC-T interface terminal locations.
8. Proceed to [Step 10](#).
9. **Top Entry Wiring.** Route the MOB, pull chain, and MBP (if installed) control wiring between the IAC-T interface terminals and the UPS cabinet interface terminals using the top entry conduit landing plates on the IAC-T and the UPS. See [Figure 12](#) for wiring access information, and [Figure 31](#) for IAC-T interface terminal locations.
10. Connect the MOB and pull chain control wiring to the IAC-T and UPS pull chain and building alarm terminals. See paragraph [3.2.3 IAC-T Interface Wiring Preparation](#) and [Table 15](#) for terminal block wiring and termination requirements. See [Table 16](#) or [Table 17](#) and [Figure 33](#) for wiring information and terminal assignments.
For a detailed view of the IAC-T terminals, see [Figure 32](#).
11. Connect the MBP control wiring to the IAC-T and UPS terminals. See paragraph [3.2.3 IAC-T Interface Wiring Preparation](#) and [Table 15](#) for terminal block wiring and termination

requirements. See [Table 16](#) or [Table 17](#) for IAC-T wiring information and terminal assignments. See [Figure 34](#) or [Figure 35](#) for UPS MBP terminal location.

For a detailed view of the IAC-T terminals, see [Figure 32](#)

12. Reinstall the internal safety shield panel removed in [Step 3](#).
13. Close the outside door and secure the latch.
14. After the IAC-T is installed and wired, return to the applicable Eaton 93PM UPS Installation and Operation manual listed in paragraph [1.7 For More Information](#) to complete the UPS wiring.

Figure 31. 93PM 200 kW IAC-T Interface Terminal Location

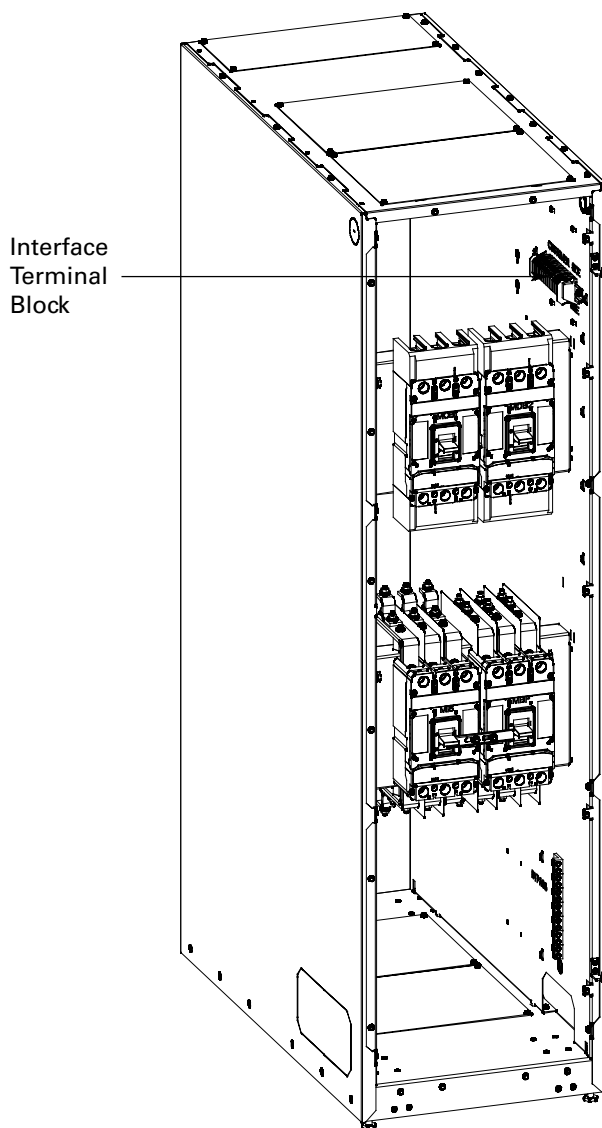

Figure 32. 93PM 200 kW IAC-T Interface Terminal Detail – Two MOBs

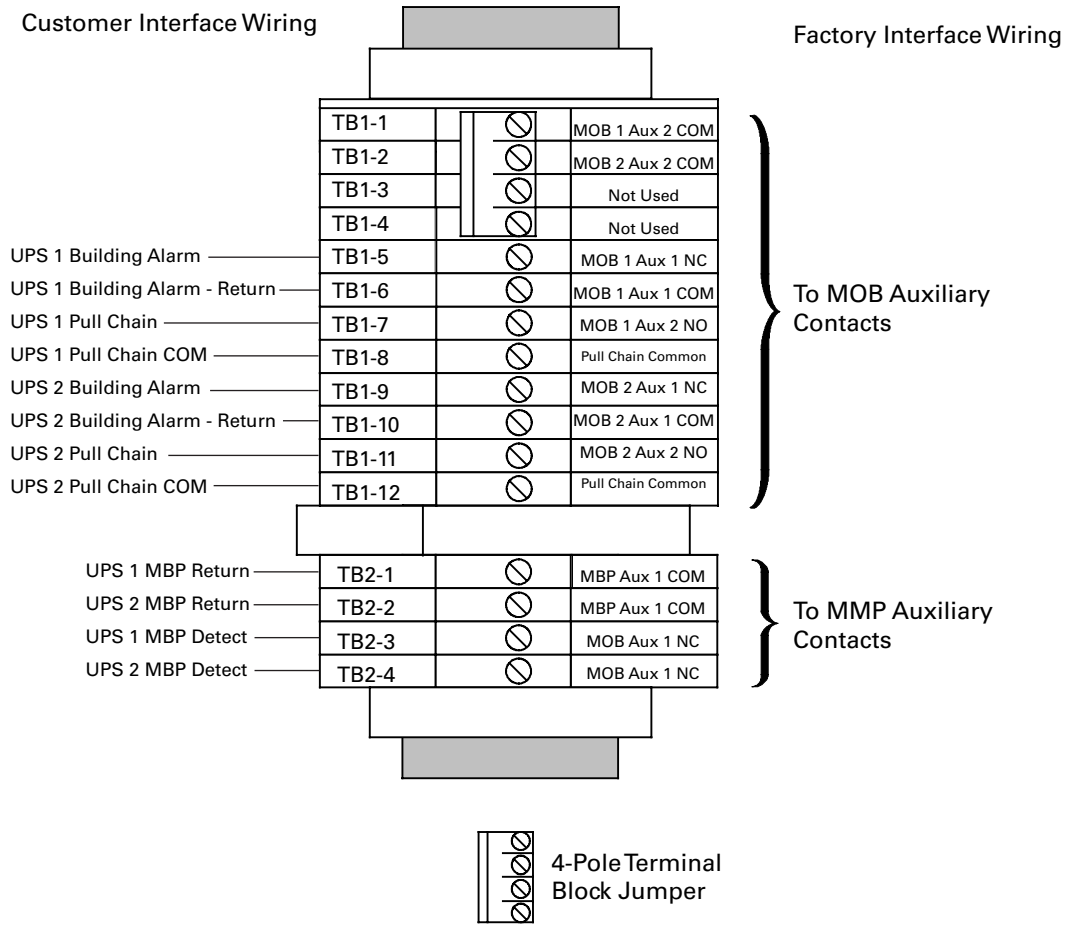

Table 15. IAC-T Interface Wiring Terminal Block Terminations

Terminal Function	Size of Pressure Termination	Tightening Torque Nm (lb in)	Type Screw	Comments
Auxiliary Contacts	#26-#12	0.4 (3.5) - 0.8 (7.1)	Slotted	Use twisted-pair wires for each input and return or common. Strip wire insulation back 10 millimeters to wire terminal blocks.

Table 16. IAC-T MOB and Pull Chain Interface Terminals

IAC-T Terminal	Name	UPS Terminal	Description
TB1-1	MOB 1 Aux #2 COM	–	
TB1-2	MOB 2 Aux #2 COM	–	Jumper terminal for MOB 1 and MOB 2 Aux 2 common connections.
TB1-3	Not Used	–	
TB1-4	Not Used	–	
TB1-5	MOB 1 Aux #1 NC	UPS 1 Building Alarm	Output: Normally Closed (NC) contact used to indicate whether MOB 1 is open. Contacts are closed when MOB 1 is open.
TB1-6	MOB 1 Aux #1 COM	UPS 1 Building Alarm Return	
TB1-7	MOB 1 Aux #2 NO	UPS 1 Pull Chain Terminal 1	Output: UPS 1 Pull Chain – Backup control for parallel operation
TB1-8	Pull Chain Common	UPS 1 Pull Chain Return Terminal 2	Output: UPS 1 Pull Chain Common
TB1-9	MOB 2 Aux #1 NC	UPS 2 Building Alarm	Output: Normally Closed (NC) contact used to indicate whether MOB 2 is open. Contacts are closed when MOB 2 is open.
TB1-10	MOB 2 Aux #1 COM	UPS 2 Building Alarm Return	
TB1-11	MOB 2 Aux #2 NO	UPS 2 Pull Chain Terminal 1	Output: UPS 2 Pull Chain – Backup control for parallel operation
TB1-12	Pull Chain Common	UPS 2 Pull Chain Return Terminal 2	Output: UPS 2 Pull Chain Common

NOTE

UPS building alarm signals are customer programmable. Customer interface wiring for the IAC-T MOBs assumes that the UPS Building Alarm is programmed to monitor Normally Closed (NC) contacts.

Any pair of unused UPS building alarm terminals may be used for the MOB interface connections.

“Return” indicates connection to electronics circuit ground. “Common” indicates connection to common side of isolated relay contact

Table 17. IAC-T MOB, MBP, and Pull Chain Interface Terminals

IAC-T Terminal	Name	UPS Terminal	Description
TB1-1	MOB 1 Aux #2 COM	–	
TB1-2	MOB 2 Aux #2 COM	–	Jumper terminal for MOB 1 and MOB 2 Aux 2 common connections.
TB1-3	Not Used	–	
TB1-4	Not Used	–	
TB1-5	MOB 1 Aux #1 NC	UPS 1 Building Alarm	Output: Normally Closed (NC) contact used to indicate whether MOB 1 is open. Contacts are closed when MOB 1 is open.
TB1-6	MOB 1 Aux #1 COM	UPS 1 Building Alarm Return	
TB1-7	MOB 1 Aux #2 NO	UPS 1 Pull Chain Terminal 1	Output: UPS 1 Pull Chain – Backup control for parallel operation
TB1-8	Pull Chain Common	UPS 1 Pull Chain Return Terminal 2	Output: UPS 1 Pull Chain Common
TB1-9	MOB 2 Aux #1 NC	UPS 2 Building Alarm	Output: Normally Closed (NC) contact used to indicate whether MOB 2 is open. Contacts are closed when MOB 2 is open.
TB1-10	MOB 2 Aux #1 COM	UPS 2 Building Alarm Return	
TB1-11	MOB 2 Aux #2 NO	UPS 2 Pull Chain Terminal 1	Output: UPS 2 Pull Chain – Backup control for parallel operation
TB1-12	Pull Chain Common	UPS 2 Pull Chain Return Terminal 2	Output: UPS 2 Pull Chain Common
TB2-1	MBP Aux 1 COM	UPS 1 MBP	Output: Normally Open (NO) contact used to indicate whether the MBP is closed and the UPS system is on maintenance bypass. Contacts are closed when the MBP is closed.
TB2-3	MBP Aux 1 NC	UPS 1 MBP Return	
TB2-2	MBP Aux 2 COM	UPS 2 MBP	Output: Normally Open (NO) contact used to indicate whether the MBP is closed and the UPS system is on maintenance bypass. Contacts are closed when the MBP is closed.
TB2-4	MBP Aux 2 NC	UPS 2 MBP Return	

NOTE

UPS building alarm signals are customer programmable. Customer interface wiring for the IAC-T MOBs assumes that the UPS Building Alarm is programmed to monitor Normally Closed (NC) contacts.

Any pair of unused UPS building alarm terminals may be used for the MOB and MBP interface connections.

“Return” indicates connection to electronics circuit ground. “Common” indicates connection to common side of isolated relay contact

Figure 33. MOB and Pull Chain Wiring

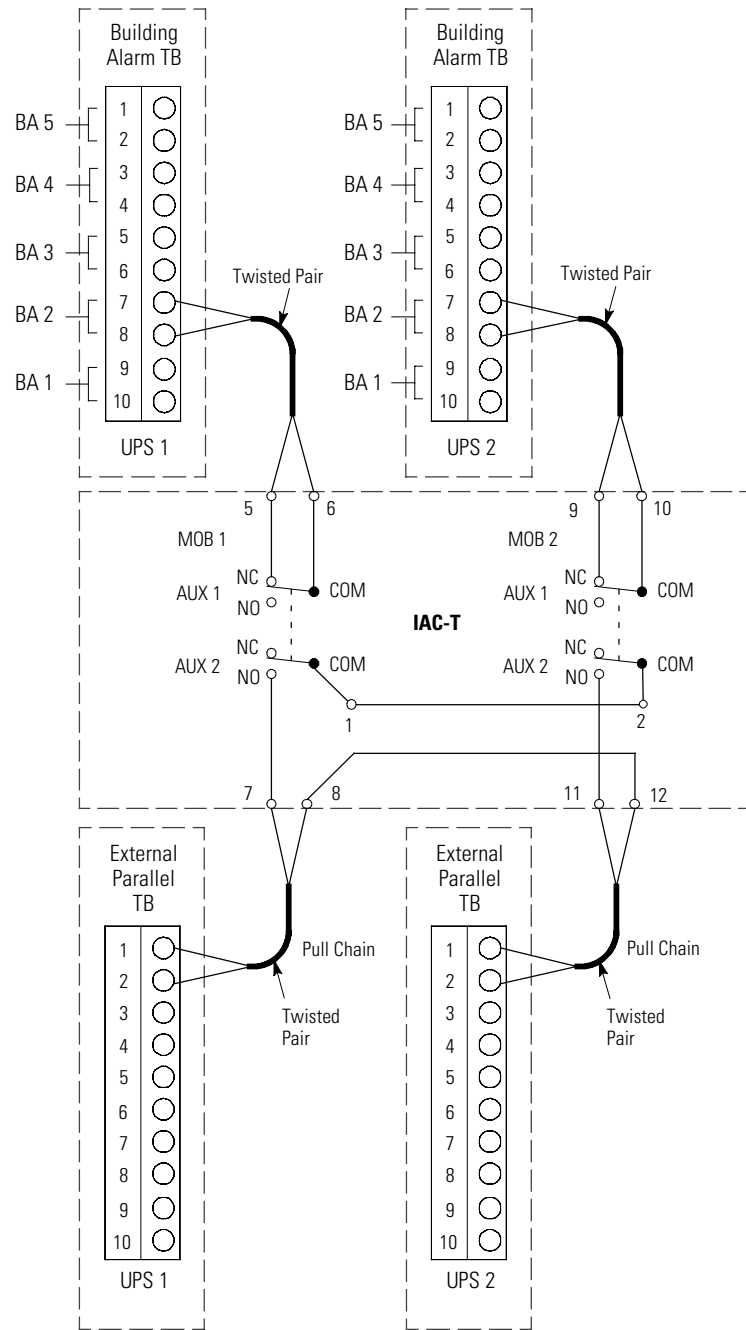

Figure 34. 150 kW Capacity UPS MBP Interface Terminal Location

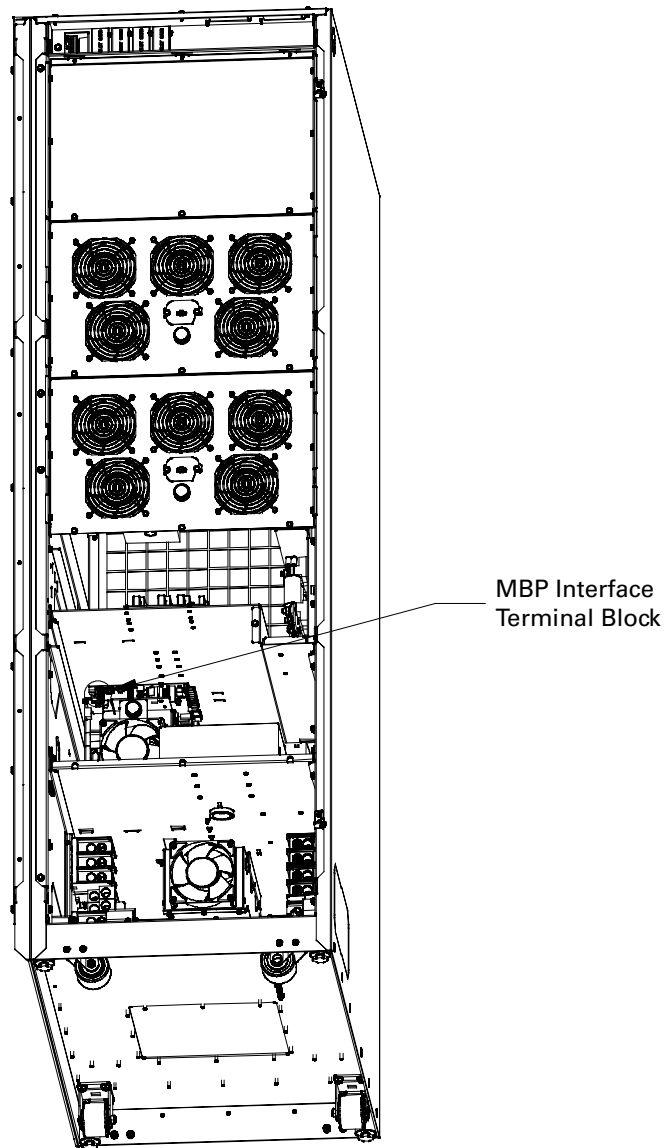

Figure 35. 150 kW Redundant and 200 kW UPS MBP Interface Terminal Location

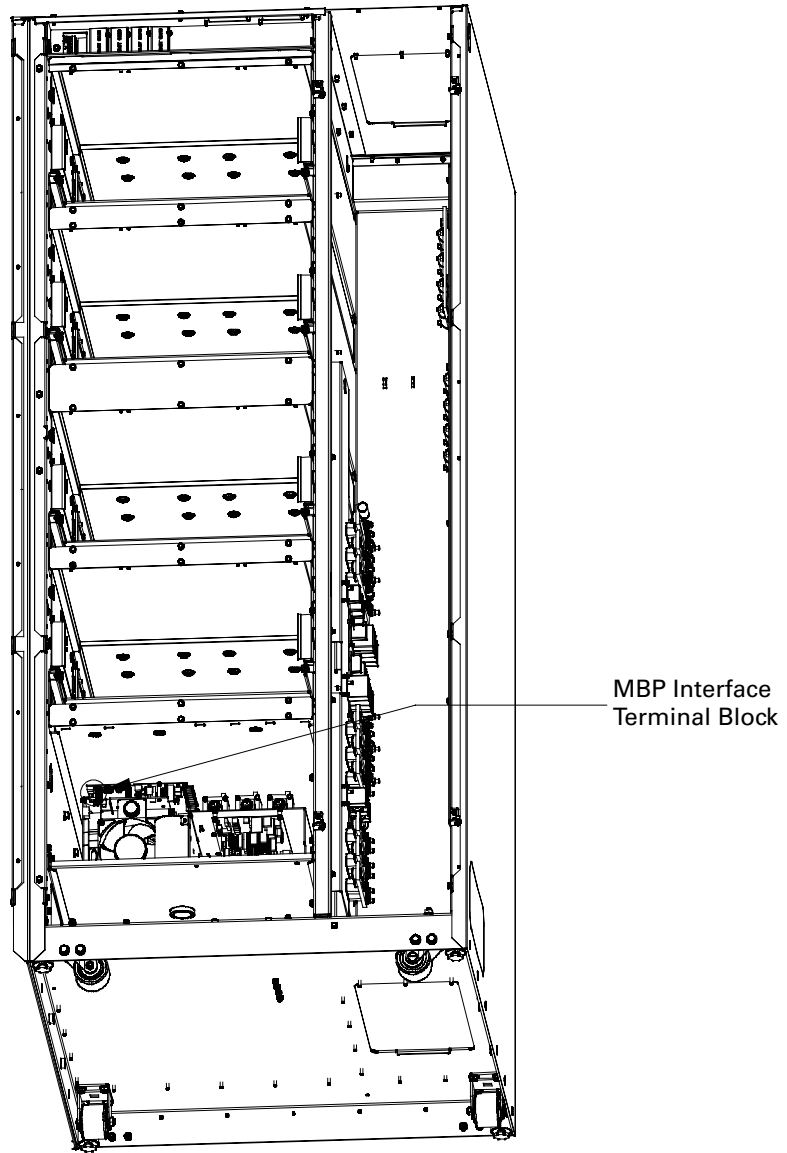
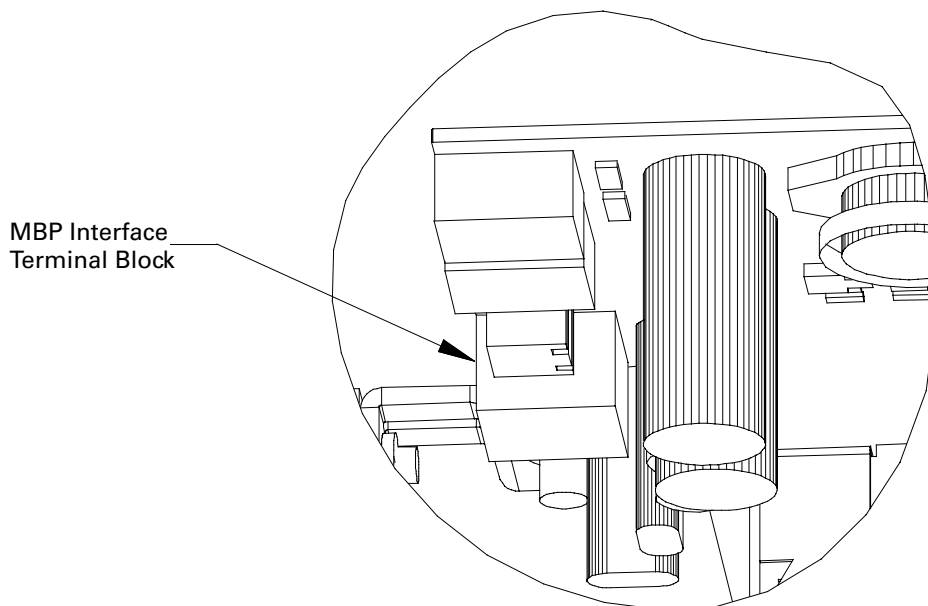

Figure 36. UPS MBP Interface Terminal Detail

4.5 Initial Startup

Startup and operational checks must be performed by an authorized Eaton Customer Service Engineer, or the warranty terms specified in [Chapter 9 Warranty](#) become void. This service is offered as part of the sales contract for the UPS. Contact an Eaton service representative in advance (usually a two-week notice is required) to reserve a preferred startup date.

4.6 Completing the Installation Checklist

The final step in installing the IAC is completing the following Installation Checklist. This checklist ensures that you have completely installed all hardware, cables, and other equipment. Complete all items listed on the checklist to ensure a smooth installation. Make a copy of the Installation Checklist before filling it out, and retain the original.

After the installation is complete, an Eaton Customer Service Engineer must verify the operation of the UPS system and commission it to support the critical load. The service representative cannot perform any installation tasks other than verifying software and operating setup parameters. Service personnel may request a copy of the completed Installation Checklist to verify all applicable equipment installations have been completed.



NOTE

The Installation Checklist **MUST** be completed prior to starting the UPS system for the first time.

4.7 Installation Checklist

- All packing materials and shipping brackets have been removed from each cabinet.
- The IAC-T is installed on a level floor suitable for computer or electronic equipment.
- The IAC-T is placed in its installed location.
- All conduits and cables are properly routed between the IAC-T and the UPS.
- All power cables are properly sized and terminated.
- A ground conductor is properly installed.
- Interface wiring between the IAC-T and UPS cabinets is properly installed.
- All terminal cover plates are installed.
- Air conditioning equipment is installed and operating correctly.
- The area around the UPS system is clean and dust-free.
- Adequate workspace exists around the IAC-T and other cabinets.
- Adequate lighting is provided around all IAC-T and UPS equipment.
- A 120 Vac service outlet is located within 7.5 meters (25 feet) of the IAC-T and UPS equipment.
- Startup and operational checks are performed by an authorized Eaton Customer Service Engineer.
- Visit www.eaton.com/pg/register to register your new Eaton UPS / Eaton UPS Accessory.

Notes:

Chapter 5 Onelines and Schematics

5.1 Onelines

Figure 37 through Figure 41 show the simplified internal structure of the Integrated Accessory Cabinet-Tie (IAC-T) configurations:

- Two Module Output Breakers (MOBs)
- Two MOBs with a Maintenance Isolation Breaker (MIS)
- Two MOBs with a MIS and a Maintenance Bypass Breaker (MBP)

Figure 37. Integrated Accessory Cabinet-Tie (IAC-T) Internal Oneline – 150 kW and 200 kW with Two MOBs

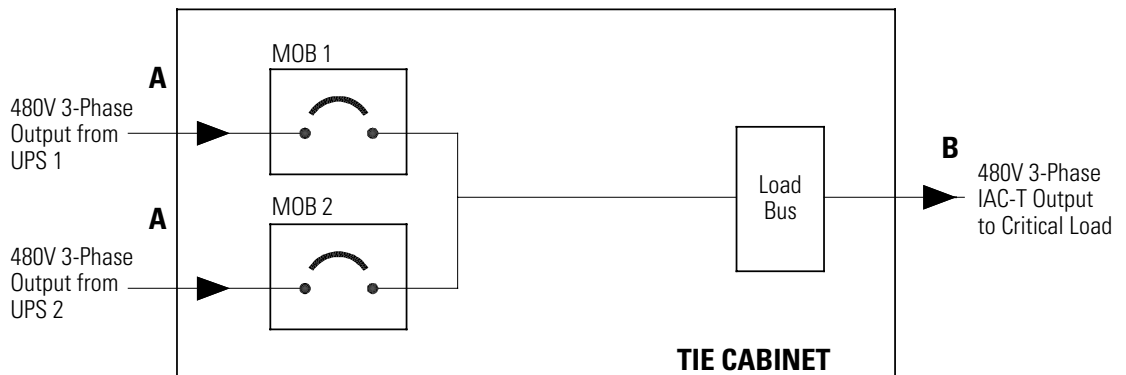

Figure 38. Integrated Accessory Cabinet-Tie (IAC-T) Internal Oneline – 150 kW (1+1 and 2+0) and 200 kW (1+1) with Two MOBs and MIS

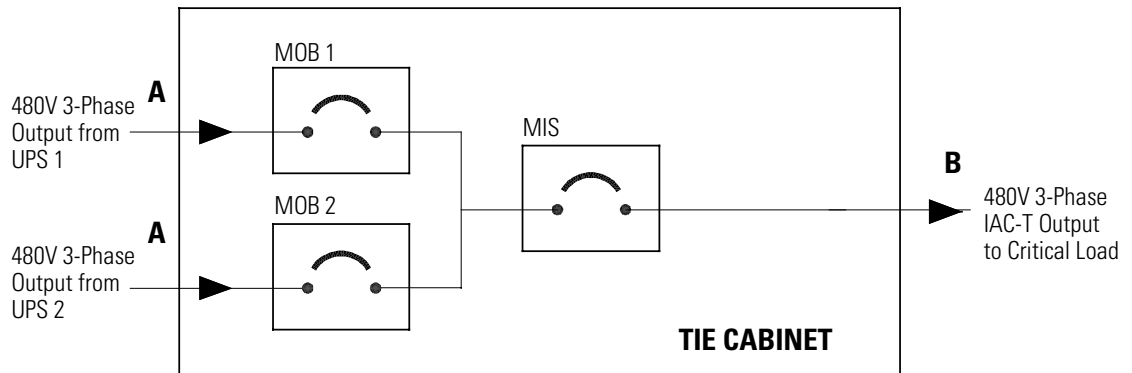

Figure 39. Integrated Accessory Cabinet-Tie (IAC-T) Internal Oneline – 200 kW (2+0) with Two MOBs and MIS

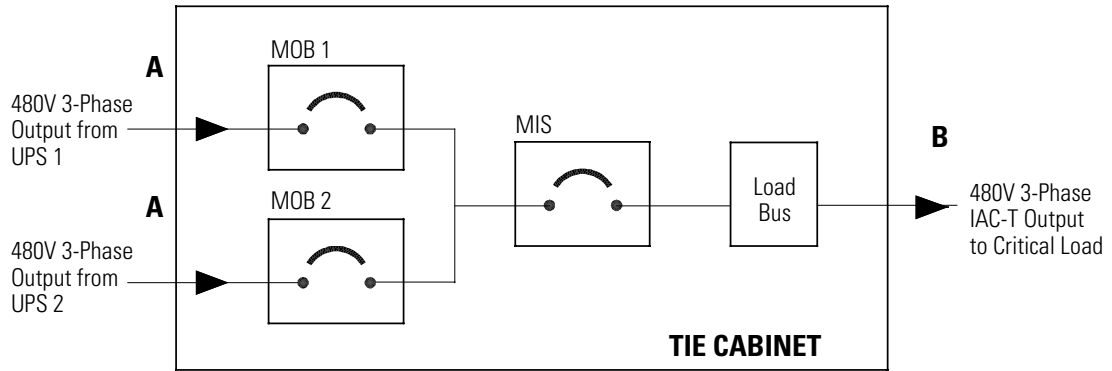

Figure 40. Integrated Accessory Cabinet-Tie (IAC-T) Internal Oneline – 150 kW (1+1 and 2+0) and 200 kW (1+1) with Two MOBs, MIS, and MBP

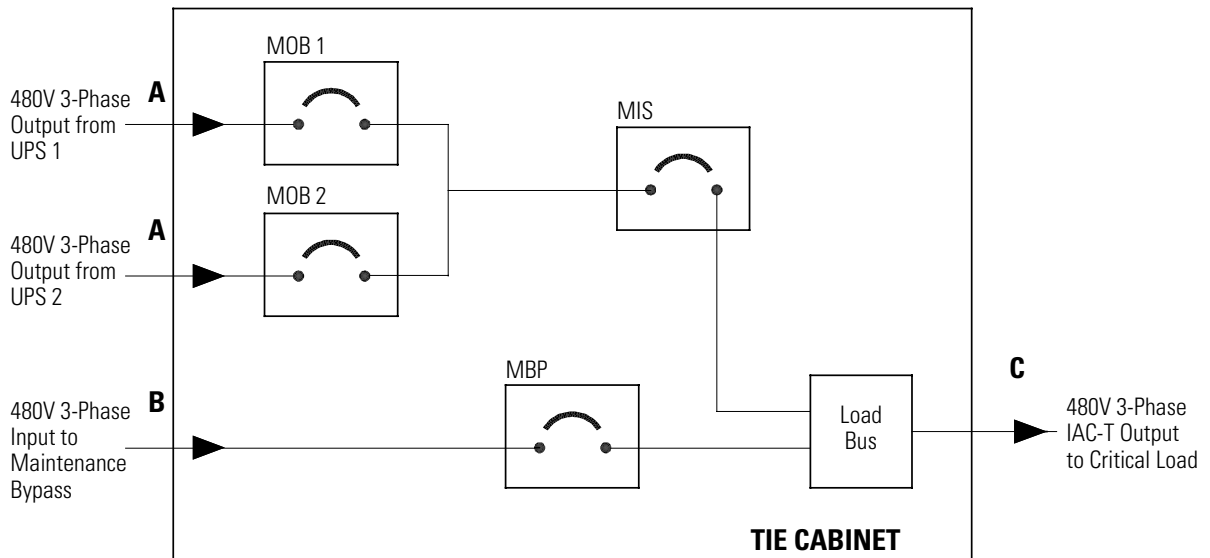
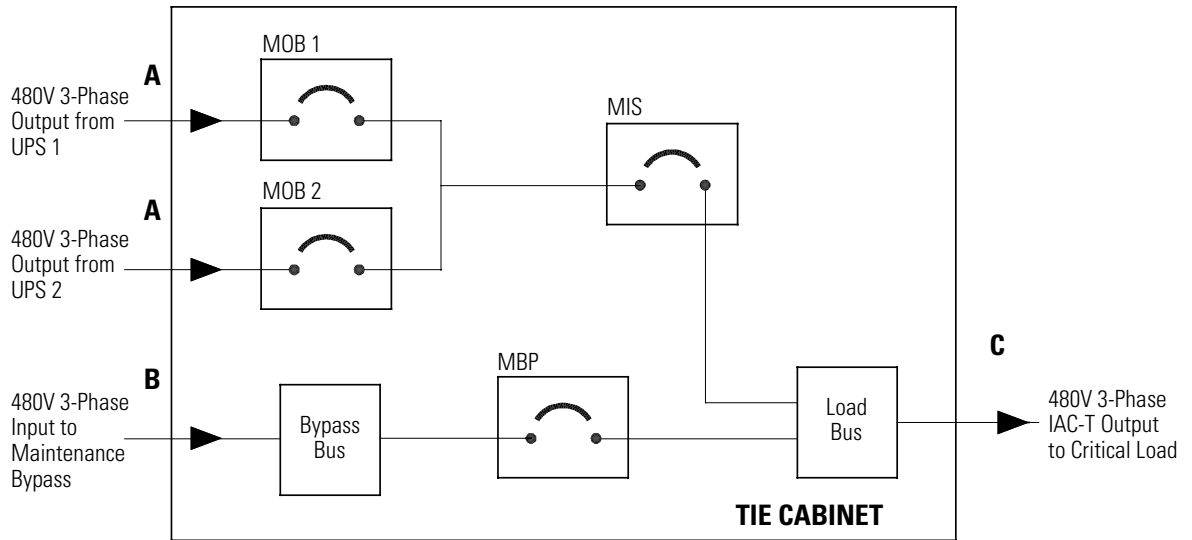

Figure 41. Integrated Accessory Cabinet-Tie (IAC-T) Internal Oneline – 200 kW (2+0) with Two MOBs, MIS, and MBP



5.2 Schematics

[Figure 42](#) through [Figure 46](#) show the IAC-T schematics.

Figure 42. Eaton 93PM IAC-T Schematic – 150 kW and 200 kW with Two MOB's

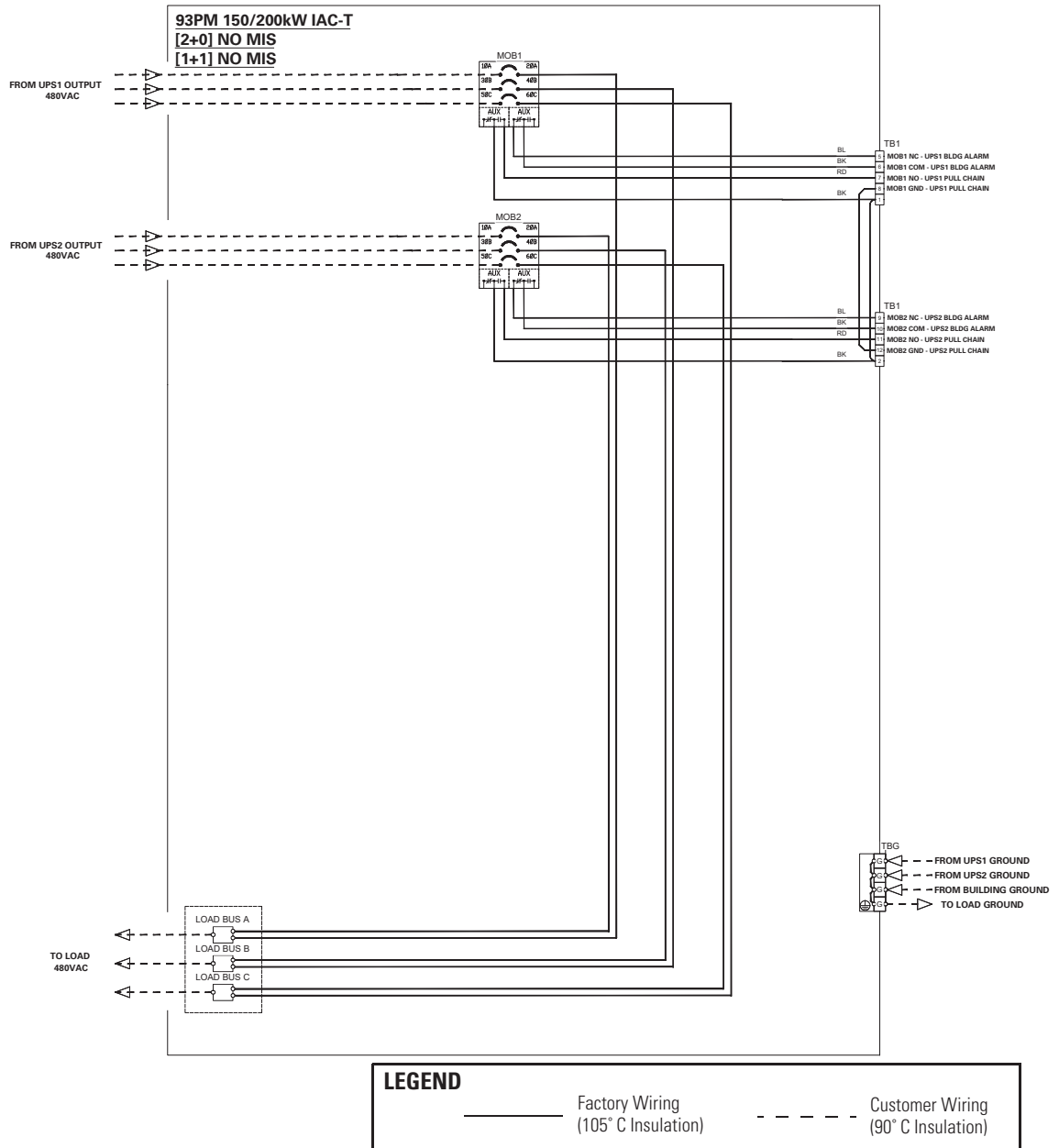

Figure 43. Eaton 93PM IAC-T Schematic – 150 kW (1+1 and 2+0) and 200 kW (1+1) with Two MOBs and MIS

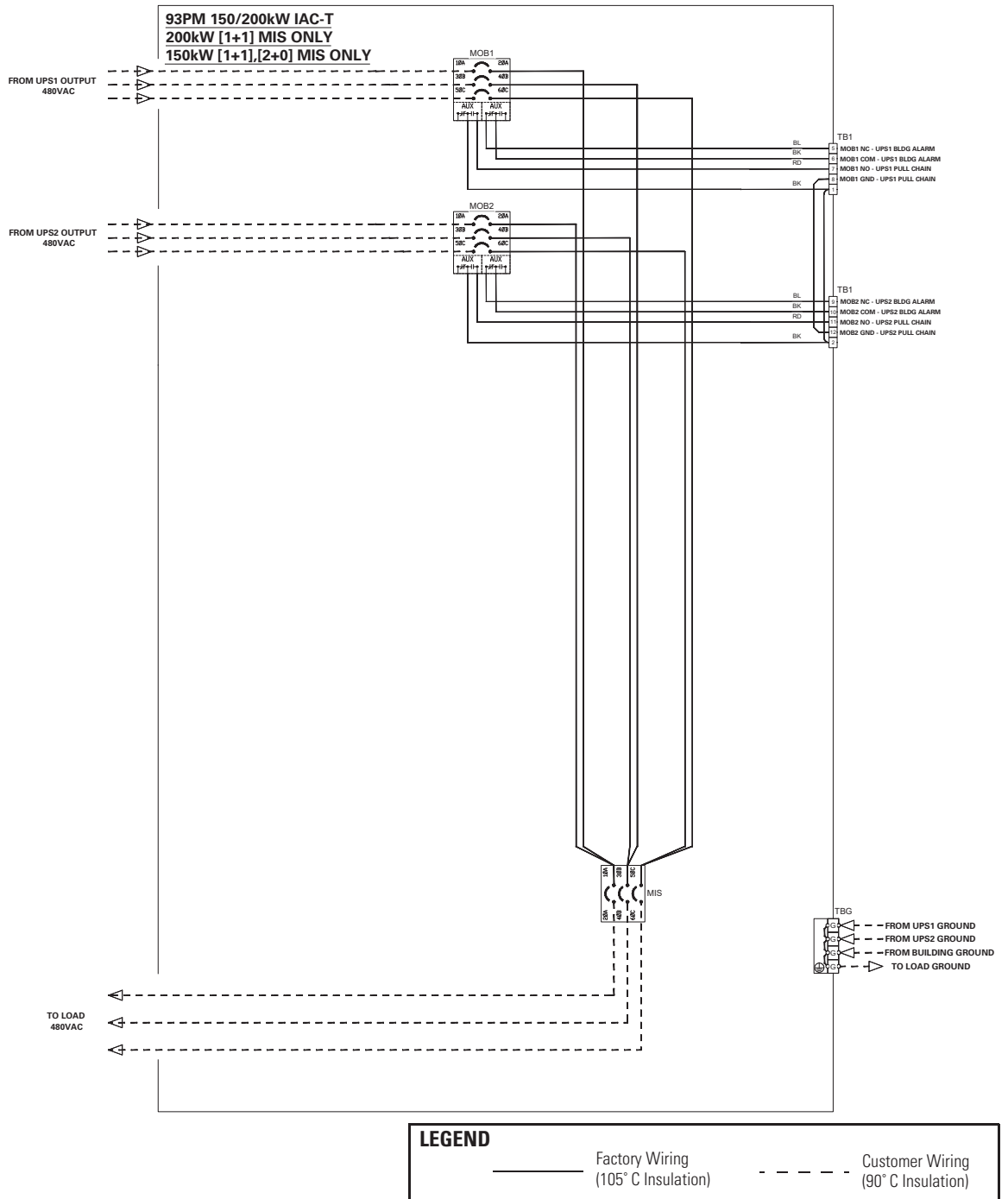

Figure 44. Eaton 93PM IAC-T Schematic – 200 kW (2+0) with Two MOBs and MIS

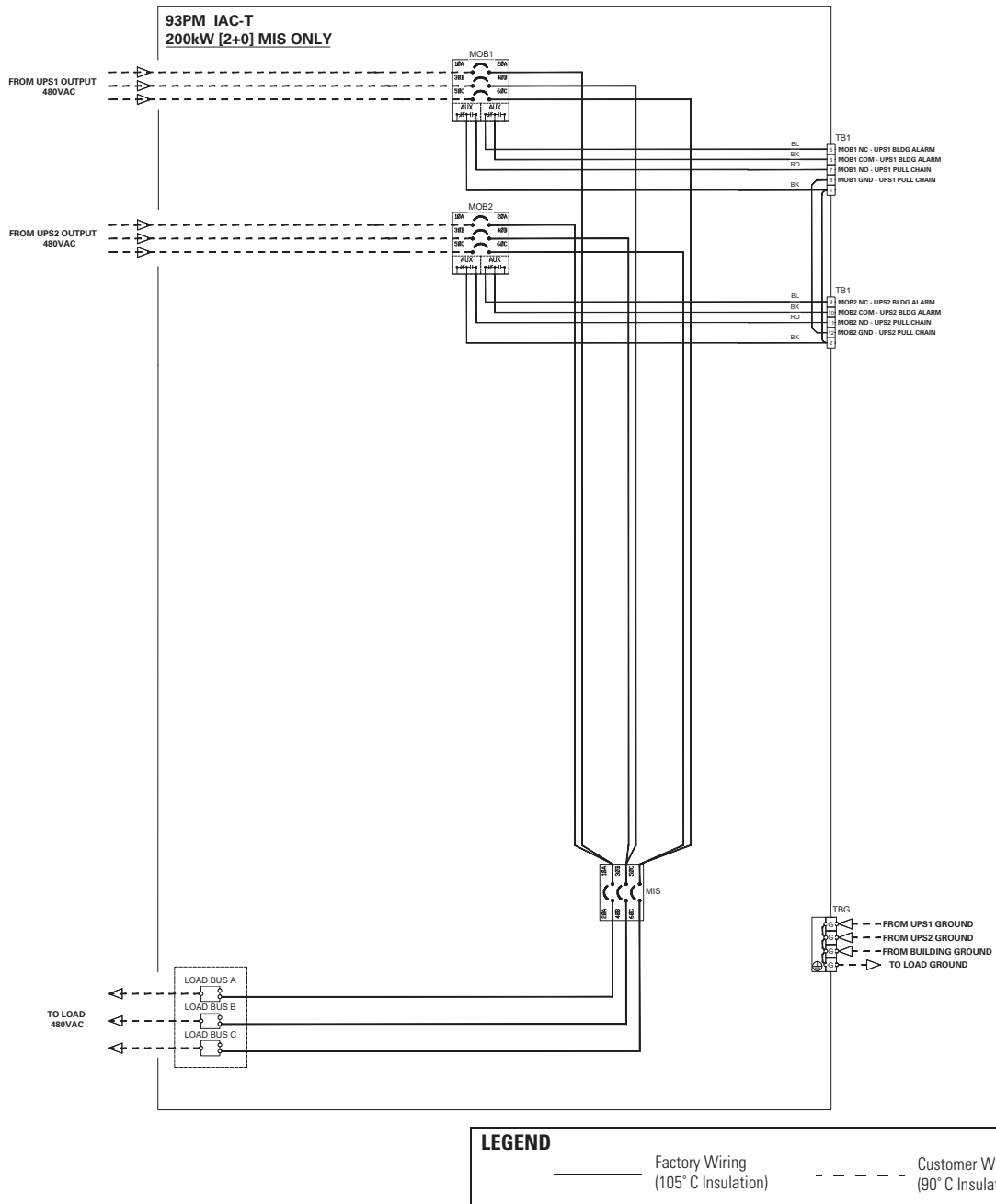

Figure 45. Eaton 93PM IAC-T Schematic – 150 kW (1+1 and 2+0) and 200 kW (1+1) with Two MOB, MIS, and MBP

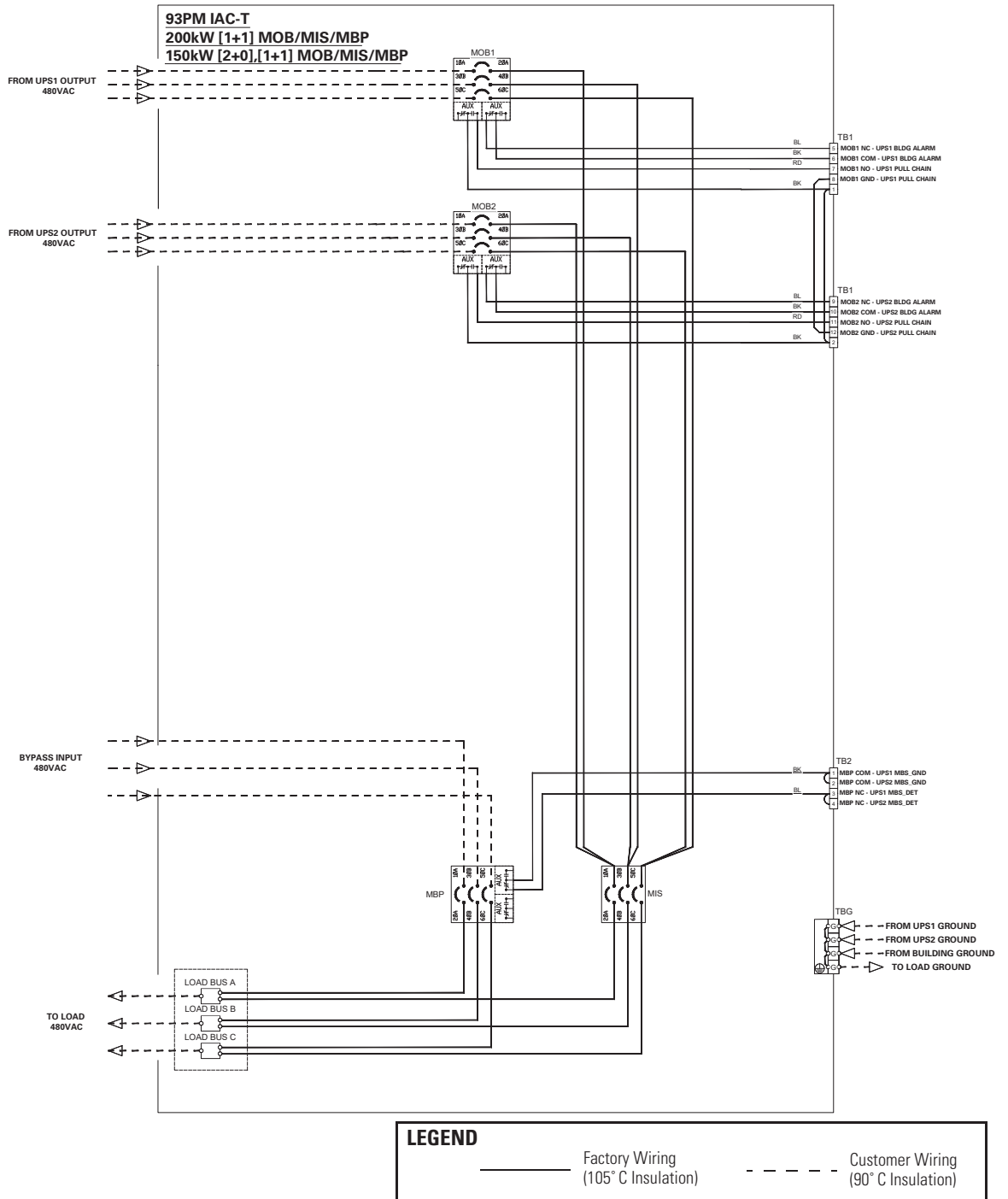
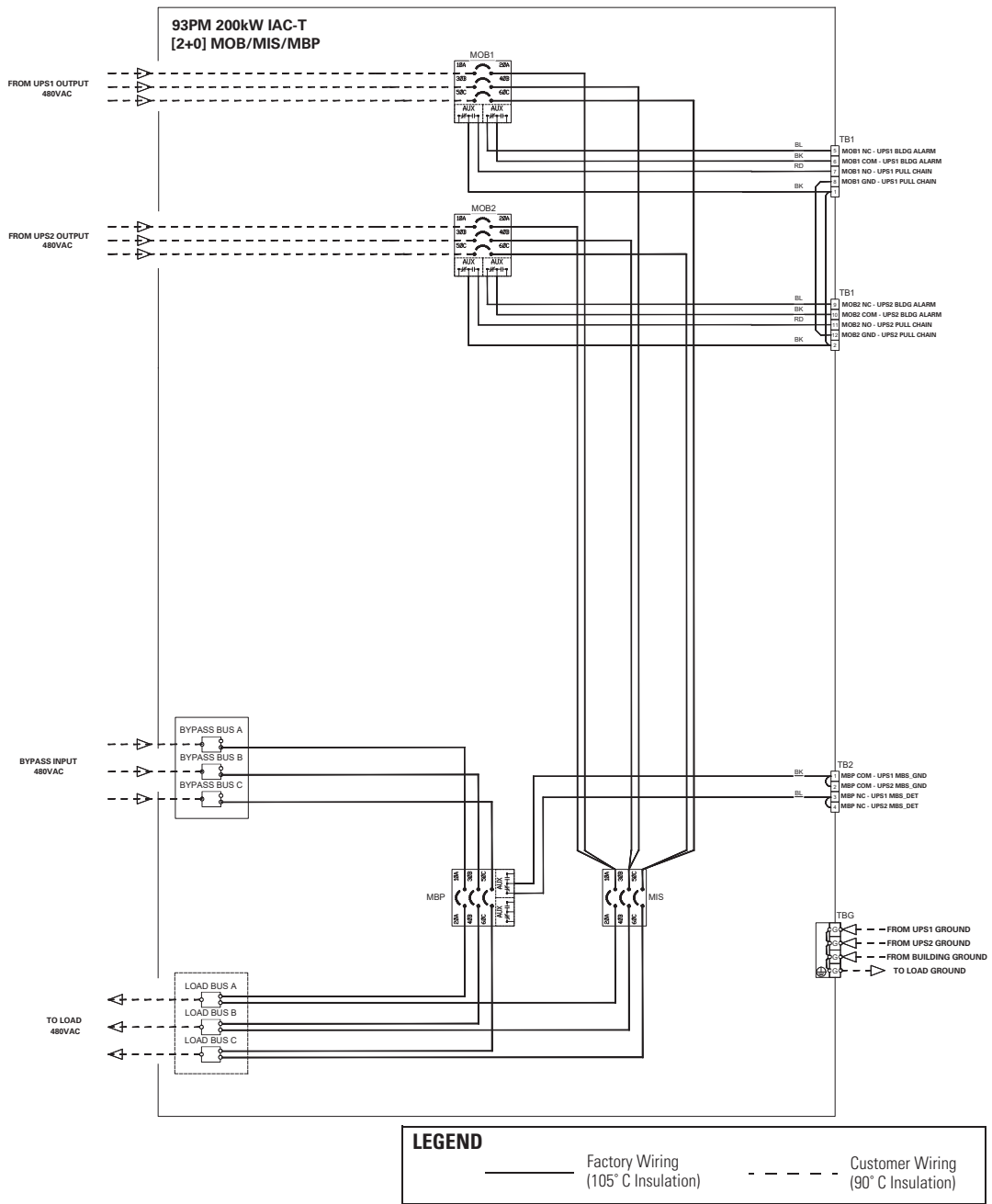

Figure 46. Eaton 93PM IAC-T Schematic – 200 kW (2+0) with Two MOBs, MIS, and MBP



Chapter 6 Integrated Accessory Cabinet-Tie Operating Instructions

This section describes how to operate the Integrated Accessory Cabinet-Tie (IAC-T).

-
- NOTE 1** Before using the IAC-T, ensure all installation tasks are complete and a preliminary startup has been performed by authorized service personnel. The preliminary startup verifies all electrical interconnections to ensure the installation was successful and the system operates properly.
- NOTE 2** Read this section of the manual and have thorough knowledge of UPS and IAC-T operation before attempting to operate any of the controls.
-

6.1 Circuit Breakers

[Figure 47](#) identifies and shows the location of the circuit breakers in the Integrated Accessory Cabinet-Tie (IAC-T). The descriptions provide a brief overview of the IAC-T breaker use.

- **Module Output Breaker 1** – The Module Output Breaker 1 (MOB 1) controls the output from UPS 1, enabling two UPS modules to be paralleled together for redundancy or increased capacity.
- **Module Output Breaker 2** – The Module Output Breaker 2 (MOB 2) controls the output from UPS 2, enabling two UPS modules to be paralleled together for redundancy or increased capacity.
- **Maintenance Isolation Breaker (optional)** – The Maintenance Isolation Breaker (MIS) provides output control to the critical load for the whole system when used without a Maintenance Bypass Breaker (MBP) and isolates the UPS from the bypass feed and the load when a Maintenance Bypass Breaker (MBP) is provided.
- **Maintenance Bypass Breaker** – The Maintenance Bypass Breaker (MBP) transfers the load from the UPS output to the bypass input feeder.

Figure 47. 93PM 150 kW IAC-T or 93PM 200 kW IAC-T Breakers

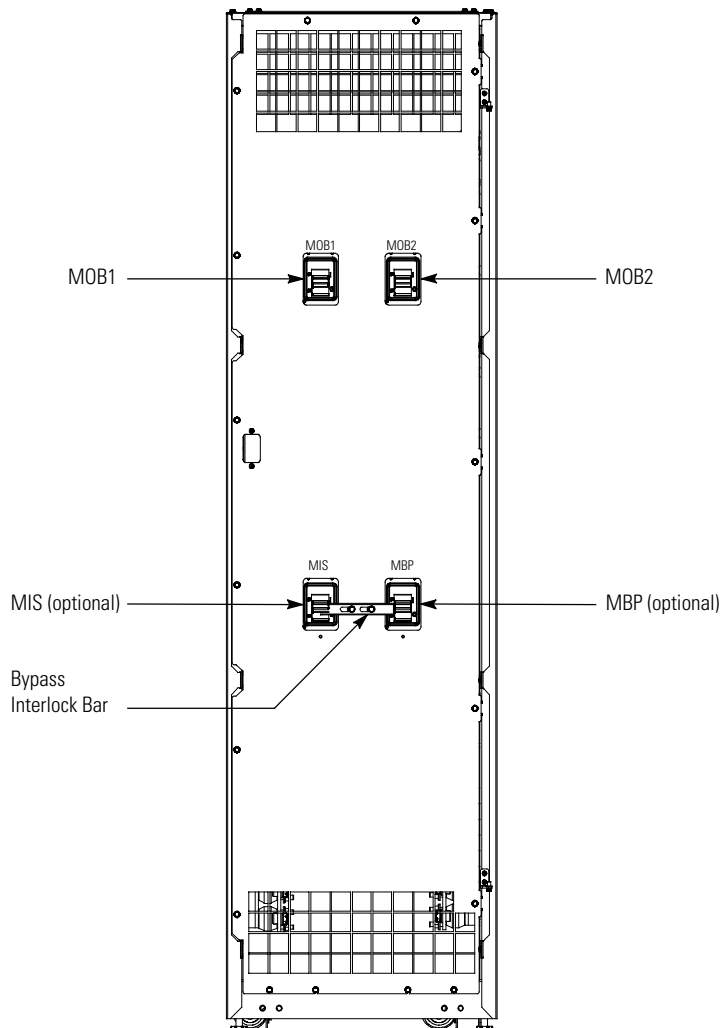

6.2 Using the UPS when an IAC-T is Installed (No MIS or MBP)

To operate the IAC-T:

1. Open the front door by lifting the latch from the bottom, turning to the right (counterclockwise), and swinging the door open.
2. Verify that the IAC-T circuit breakers are set as follows (see [Figure 47](#) for breaker locations):

MOB 1	CLOSED
MOB 2	CLOSED

3. Start the UPS. Refer to the applicable Eaton 93PM UPS Installation and Operation manual listed in paragraph [1.7 For More Information](#), for multiple UPS parallel operating procedures.
4. Close the door and secure the latch.

6.3 Using the UPS when an IAC-T is Installed (with a MIS)

To operate the IAC-T:

1. Open the front door by lifting the latch from the bottom, turning to the right (counterclockwise), and swinging the door open.
2. Verify that the IAC-T circuit breakers are set as follows (see [Figure 47](#) for breaker locations):

MOB 1	CLOSED
MOB 2	CLOSED
MIS	CLOSED

3. Start the UPS. Refer to the applicable Eaton 93PM UPS Installation and Operation manual listed in paragraph [1.7 For More Information](#), for multiple UPS parallel operating procedures.
4. Close the door and secure the latch.

6.4 Using the UPS when an IAC-T is Installed (with a MIS and a MBP)

To operate the IAC-T:

1. Open the front door by lifting the latch from the bottom, turning to the right (counterclockwise), and swinging the door open.
2. Verify that the IAC-T circuit breakers are set as follows (see [Figure 47](#) for breaker locations):

MOB 1	CLOSED
MOB 2	CLOSED
MBP	OPEN
MIS	CLOSED

3. Start the UPS. Refer to the applicable Eaton 93PM UPS Installation and Operation manual listed in paragraph [1.7 For More Information](#), for multiple UPS parallel operating procedures.
4. Close the door and secure the latch.

6.4.1 Transferring the UPS to Maintenance Bypass (IAC-T with a MIS and a MBP)



Only trained personnel familiar with the operation of this equipment should transfer loads. Failure to follow this transfer sequence may cause loss of power to loads.



In Bypass mode, the critical load is not protected from commercial power interruptions and abnormalities.

To transfer the load to maintenance bypass:

1. Open the front door by lifting the latch from the bottom, turning to the right (counterclockwise), and swinging the door open.
2. Transfer the UPS from normal mode to bypass mode. Refer to the applicable Eaton 93PM UPS Installation and Operation manual listed in paragraph [1.7 For More Information](#) for UPS operating procedures.

 **CAUTION**

Failure to close the MBP before opening the MIS will result in the loss of power to the critical load.

3. Close the MBP
4. Slide the interlock bar to the right (see [Figure 47](#)).
5. Open the MIS.
The critical load is supplied by the maintenance bypass source.
6. Open the MOBs
7. Close the door and secure the latch.
8. Shut down the UPS. Refer to the applicable Eaton 93PM UPS Installation and Operation manual listed in paragraph [1.7 For More Information](#) for UPS operating procedures.

6.4.2 Transferring the UPS from Maintenance Bypass (IAC-T with a MIS and a MBP)

 **CAUTION**

Only trained personnel familiar with the operation of this equipment should transfer loads. Failure to follow this transfer sequence may cause loss of power to loads.

To transfer the load from maintenance bypass:

1. Open the front door by lifting the latch from the bottom, turning to the right (counterclockwise), and swinging the door open.
2. Close the MOBs
3. Start the UPS in bypass mode. Refer to the applicable Eaton 93PM UPS Installation and Operation manual listed in paragraph [1.7 For More Information](#) for UPS operating procedures.

 **CAUTION**

Failure to close the MIS before opening the MBP will result in the loss of power to the critical load.

4. Close the MIS.
5. Slide the interlock bar to the left (see [Figure 47](#)).
6. Open the MBP.
7. Close the door and secure the latch.
8. Transfer the UPS to Normal mode. Refer to the applicable Eaton 93PM UPS Installation and Operation manual listed in paragraph [1.7 For More Information](#) for UPS operating procedures.

Chapter 7 Maintenance

The components inside the Integrated Accessory Cabinet-Tie (IAC-T) are secured to a sturdy metal frame. All repairable parts and assemblies are located for easy removal, with very little disassembly. This design allows authorized service personnel to perform routine maintenance and servicing quickly.

You must schedule periodic performance checks of the UPS system to keep it running properly. Regular routine checks of operation and system parameters enable your system to function efficiently for many trouble-free years.

7.1 Important Safety Instructions

Remember that your UPS system is designed to supply power **EVEN WHEN DISCONNECTED FROM THE UTILITY POWER.**



WARNING

- No user serviceable components.
 - Servicing and maintenance should be performed by qualified service personnel only.
 - **LETHAL VOLTAGE PRESENT.** This unit should not be operated with the cabinet doors open or protective panels removed. Do not make any assumptions about the electrical state of any cabinet in the UPS system.
-

7.2 Performing Preventive Maintenance

The UPS system requires very little preventive maintenance. However, the system should be inspected periodically to verify that the units are operating normally. Record maintenance results and any corrective actions in a suitable log.

7.2.1 DAILY Maintenance

Perform the following steps daily:

1. Check the area surrounding the UPS system. Ensure the area is not cluttered, allowing free access to the unit.
2. Ensure the air intakes on the Accessory cabinets are not blocked.
3. Ensure the operating environment is within the parameters specified in paragraph [3.2.1 Environmental and Installation Considerations](#) and [Chapter 8 Product Specifications](#).

7.2.2 PERIODIC Maintenance

Periodic inspections of the IACs should be made to determine if components, wiring, and connections exhibit evidence of overheating. Particular attention should be given to the compression lug connections. Maintenance procedures should specify that the compression lug connections be retorqued to values listed in this manual.

7.2.3 ANNUAL Maintenance

Annual preventive maintenance should be performed only by authorized service personnel familiar with maintenance and servicing of the UPS system. Contact an Eaton service representative for more information about service offerings.

7.3 Maintenance Training

A basic training course, available from Eaton Corporation, gives you a competent working knowledge of the UPS system operation and teaches you how to perform first level corrective maintenance. For more information about training and other services, contact the Help Desk (see paragraph [1.8 Getting Help](#)).

Chapter 8 Product Specifications

This section provides the following specifications:

- Model Number
- Input specifications
- Output specifications
- Environmental and safety specifications

8.1 Model Numbers

The Integrated Accessory Cabinet-Tie (IAC-T) is available in the model listed below to meet the needs of the Eaton 93PM UPS product line.

Integrated Accessory Cabinet Models	Description
Eaton 93PM 150 kW IAC-T	IAC-T for the Eaton 93PM 150 kW UPS
Eaton 93PM 200 kW IAC-T	IAC-T for the Eaton 93PM 200 kW UPS

8.2 Specifications

The following sections detail the input, output, and environmental and safety specifications for the IAC-T.

8.2.1 Input

Operating Input Voltage and Frequency	480 Vac, 50/60 Hz
Input Wiring	3 wire+ ground – No neutral
Operating Input Current	See Table 3 through Table 8 .

8.2.2 Output

Operating Output Voltage and Frequency	480 Vac, 50/60 Hz
Output Wiring	3 wire+ ground – No neutral
Output Current	See Table 3 through Table 8 .

8.2.3 Environmental and Safety Specifications

Operating Temperature	5 to 40°C (41 to 104°F) without derating. The recommended operating temperature is 25°C (77°F)
Storage Temperature	-25 to +55°C (-13 to +131°F)
Operating Altitude	Maximum 1500m (5000 ft) at 40°C without derating
Transit Altitude	15000m (49213 ft)
Ventilation	Natural Convection

Product Specifications

Relative Humidity (operating and storage)	5 to 95%, noncondensing
Acoustical Noise	Not applicable
Safety Conformance	UL1778 4 th edition
Agency Markings	cULus

Chapter 9 Warranty

9.1 Limited Factory Warranty for Three-Phase Eaton 93PM UPS and 93PM UPS Accessory Products

WARRANTOR: The warrantor for the limited warranties set forth herein is Eaton ("Eaton").

LIMITED WARRANTY: This limited warranty (this "Warranty") applies only to the original end-user (the "End-User") of the Eaton Three-Phase 93PM UPS and 93PM UPS Accessory Products (the "Product") and cannot be transferred. This restriction applies even in the event that the Product is initially sold by Eaton for resale to an End-User. This Warranty gives you specific legal rights, and you may also have other rights which vary from State to State (or jurisdiction to jurisdiction).

WHAT THIS LIMITED WARRANTY COVERS: The warrantor warrants, with the terms of this Warranty, that the Eaton three-phase UPS electronics, Eaton-built accessories, and Eaton-built battery cabinets (individually and collectively, the "Warranted Items") are free from defects in material and workmanship.

For Product installed (and currently located) in the fifty (50) United States and the District of Columbia, if, in the opinion of Eaton, a Warranted Item is defective, Eaton's sole obligation, at the option of Eaton, will be to refurbish or replace such defective Warranted Item (including the costs of providing diagnosis, service, and labor ["labor coverage"]). The defective Warranted Item will be refurbished or replaced onsite at the End-User's location or such other location as determined by Eaton. Any parts that are replaced may be new or reconditioned. All parts replaced by Eaton shall become the property of Eaton.

For Product installed (and currently located) outside the fifty (50) United States and the District of Columbia, if, in the opinion of Eaton, a Warranted Item is defective, Eaton's sole obligation, at the option of Eaton, will be to refurbish or replace such defective Warranted Item (not including the costs of labor coverage). The defective Warranted Item will be refurbished or replaced onsite at the End-User's location or such other location as determined by Eaton. Any parts that are replaced may be new or reconditioned. All parts replaced by Eaton shall become the property of Eaton.

LIMITED WARRANTY PERIOD: The period covered by this Warranty for Product installed (and currently located) in the fifty (50) United States and the District of Columbia is six (6) months from the date of Product purchase for labor coverage when no startup is performed by an authorized Eaton Customer Service Engineer or Agent or twelve (12) months from the date of Product purchase with startup performed by an authorized Eaton Customer Service Engineer or Agent and twelve (12) months from the date of Product purchase or eighteen (18) months from date of Product shipment, whichever occurs first, for the refurbishment/replacement of parts.

The period covered by this Warranty for Product installed (and currently located) outside the fifty (50) United States and the District of Columbia is twelve (12) months from the date of Product purchase or eighteen (18) months from the date of Product shipment, whichever occurs first, for the refurbishment/replacement of parts.

WHAT THIS LIMITED WARRANTY DOES NOT COVER: This Warranty does not cover any defects or damages caused by: (a) failure to properly store the Product before installation, including the "trickle charge" of batteries no later than the date indicated on the packaging; (b) shipping and delivery of the Product if shipping is FOB Factory; (c) neglect, accident, fire, flood, lightning, vandalism, acts of God, Customer's neglect, abuse, misuse, misapplication, incorrect installation; (d) repair or alteration not authorized in writing by Eaton personnel or performed by an authorized Eaton Customer Service Engineer or Agent; or (e) improper testing, operation, maintenance, adjustment, or any modification of any kind not authorized in writing by Eaton personnel or performed by an authorized Eaton Customer Service Engineer or Agent.

This Warranty is not valid: if the Product's serial numbers have been removed or are illegible. Any Warranted Items repaired or replaced pursuant to this Warranty will be warranted for the remaining portion of the original Warranty subject to all the terms thereof. Eaton does not provide a labor warranty for Product located outside of the fifty (50) United States or the District of Columbia. **Any equipment, parts, or materials included in the Product and not manufactured by Eaton are warranted solely by the manufacturer of such equipment, parts, or materials and are not included as part of this Warranty. Batteries are not warranted by Eaton.**

THIS WARRANTY IS THE ENDUSER'S SOLE REMEDY AND IS EXPRESSLY IN LIEU OF, AND THERE ARE NO OTHER, EXPRESSED OR IMPLIED GUARANTEES OR WARRANTIES (INCLUDING ANY IMPLIED WARRANTY OF MERCHANTABILITY OR FITNESS FOR ANY PURPOSE, WHICH ARE EXPRESSLY DISCLAIMED). SOME STATES OR JURISDICTIONS DO NOT ALLOW THE EXCLUSION OF EXPRESS OR IMPLIED WARRANTIES, SO THE ABOVE EXCLUSION MAY NOT APPLY TO YOU. IN THAT EVENT, SUCH WARRANTIES ARE LIMITED IN DURATION TO THE LIMITED WARRANTY PERIOD. SOME STATES OR JURISDICTIONS DO NOT ALLOW LIMITATIONS ON HOW LONG AN IMPLIED WARRANTY LASTS OR THE EXCLUSION OR LIMITATION OF INCIDENTAL OR CONSEQUENTIAL DAMAGES, SO THE ABOVE LIMITATIONS AND/OR EXCLUSIONS MAY NOT APPLY TO YOU.

LIMITATION OF LIABILITY: In no event shall Eaton be liable for any indirect, incidental, special or consequential damages of any kind or type whatsoever, resulting from or in connection with any claim or cause of action, whether brought in contract or in tort (including negligence and strict liability). Some States or jurisdictions do not allow the exclusion of limitation of incidental or consequential damages, so the above limitation or exclusion may not apply to you. Eaton shall not be responsible for failure to provide service or parts due to causes beyond Eaton's reasonable control. In no case will Eaton's liability under this Warranty exceed the replacement value of the Warranted Items.

END-USER'S OBLIGATIONS: In order to receive the benefits of this Warranty, the End-User must register the product warranty (via mail or online at www.eaton.com/pg/register "product registration"); use the Product in a normal way; follow the Product's user's guide; and protect against further damage to the Product if there is a covered defect.

OTHER LIMITATIONS: Eaton's obligations under this Warranty are expressly conditioned upon receipt by Eaton of all payments due to it (including interest charges, if any). During such time as Eaton has not received payment of any amount due to it for the Product, in accordance with the contract terms under which the Product is sold, Eaton shall have no obligation under this Warranty. Also during such time, the period of this Warranty shall continue to run and the expiration of this Warranty shall not be extended upon payment of any overdue or unpaid amounts.

COSTS NOT RELATED TO WARRANTY: The End-User shall be invoiced for, and shall pay for, all services not expressly provided for by the terms of this Warranty, including without limitation site calls involving an inspection that determines no corrective maintenance is required. Any costs for replacement equipment, installation, materials, freight charges, travel expenses, or labor of Eaton representatives outside the terms of this Warranty will be borne by the End-User.

OBTAINING WARRANTY SERVICE: In the USA, call the Eaton Customer Reliability Center 7x24 at 800-843-9433. Outside of the USA, call your local Eaton sales or service representative, or call the Eaton Customer Reliability Center in the United States at 919845-3633. For comments or questions about this Limited Factory Warranty, write to the Customer Quality Representative, 8609 Six Forks Road, Raleigh, North Carolina 27615 USA.



P-164000306 03