

# Eaton® 93E Sidecar Integrated Accessory Cabinet-Bypass

30SIAC-B and 60SIAC-B

Installation and Operation Manual



*Powering Business Worldwide*



# **Eaton® 93E Sidecar Integrated Accessory Cabinet-Bypass**

30SIAC-B and 60SIAC-B  
Installation and Operation Manual



*Powering Business Worldwide*

---

**IMPORTANT SAFETY INSTRUCTIONS SAVE THESE INSTRUCTIONS**

---

This manual contains important instructions that you should follow during installation and maintenance of the UPS and batteries. Please read all instructions before operating the equipment and save this manual for future reference.

---

---

**CONSIGNES DE SÉCURITÉ IMPORTANTES CONSERVER CES INSTRUCTIONS**

---

Ce manuel comporte des instructions importantes que vous êtes invité à suivre lors de toute procédure d'installation et de maintenance des batteries et de l'onduleur. Veuillez consulter entièrement ces instructions avant de faire fonctionner l'équipement et conserver ce manuel afin de pouvoir vous y reporter ultérieurement.

---

Eaton is registered trademarks of Eaton Corporation or its subsidiaries and affiliates. National Electrical Code and NEC are registered trademarks of National Fire Protection Association, Inc. All other trademarks are property of their respective companies.

©Copyright 2013–2015 Eaton Corporation, Raleigh, NC, USA. All rights reserved. No part of this document may be reproduced in any way without the express written approval of Eaton Corporation.

# Table of Contents

<b>1</b>	<b>INTRODUCTION</b>	<b>1-1</b>
1.1	Features	1-1
1.2	Installation Features	1-1
1.3	Model Configurations	1-1
1.4	Using This Manual	1-4
1.5	Conventions Used in This Manual	1-4
1.6	Symbols, Controls, and Indicators	1-4
1.7	For More Information	1-5
1.8	Getting Help	1-5
<b>2</b>	<b>SAFETY WARNINGS</b>	<b>2-1</b>
<b>SECTION 1 — INSTALLATION</b>		
<b>3</b>	<b>INSTALLATION PLAN AND UNPACKING</b>	<b>3-1</b>
3.1	Creating an Installation Plan	3-1
3.2	Preparing the Site	3-1
3.2.1	Environmental and Installation Considerations	3-1
3.2.2	SIAC-B Power Wiring Preparation	3-9
3.2.3	SIAC-B Interface Wiring Preparation	3-13
3.3	Inspecting and Unpacking the SIAC-B	3-14
<b>4</b>	<b>INSTALLATION</b>	<b>4-1</b>
4.1	Preliminary Installation Information	4-1
4.2	Unloading the SIAC-B from the Pallet and Mechanical Installation	4-1
4.3	Installing the SIAC-B Prewired Cables	4-7
4.4	Installing SIAC-B External Power Wiring	4-7
4.5	Installing SIAC-B Interface Connections	4-16
4.6	Wireway Cover and Splice Installation	4-18
4.7	Initial Startup	4-20
4.8	Completing the Installation Checklist	4-20
<b>SECTION 2 — OPERATION</b>		
<b>5</b>	<b>ONELINES AND SCHEMATICS</b>	<b>5-1</b>
5.1	Onelines	5-1
5.2	System Onelines	5-3
5.3	Schematics	5-15
<b>6</b>	<b>SIDECAR INTEGRATED ACCESSORY CABINET-BYPASS OPERATING INSTRUCTIONS</b>	<b>6-1</b>
6.1	Circuit Breakers	6-1
6.2	Operation	6-4
6.2.1	Using the UPS when an SIAC-B is Installed	6-4
6.2.2	Transferring the UPS to Maintenance Bypass using an SIAC-B	6-4
6.2.3	Transferring the UPS from Maintenance Bypass using an SIAC-B	6-5

Table of Contents

- 7 MAINTENANCE..... 7-1**
  - 7.1 Important Safety Instructions ..... 7-1
  - 7.2 Performing Preventive Maintenance..... 7-1
    - 7.2.1 DAILY Maintenance ..... 7-1
    - 7.2.2 PERIODIC Maintenance ..... 7-1
    - 7.2.3 ANNUAL Maintenance ..... 7-1
  - 7.3 Maintenance Training ..... 7-1
  
- 8 PRODUCT SPECIFICATIONS..... 8-1**
  - 8.1 Model Numbers ..... 8-1
  - 8.2 Specifications ..... 8-1
    - 8.2.1 Input ..... 8-1
    - 8.2.2 Output ..... 8-1
    - 8.2.3 Environmental and Safety Specifications ..... 8-1
  
- WARRANTY..... W-1**

## List of Figures

Figure 1-1.	Eaton 93E 30SIAC-B and Eaton 93E 60SIAC-B . . . . .	1-2
Figure 1-2.	Eaton 93E 30SIAC-B attached to an Eaton 93E 30 kVA UPS . . . . .	1-3
Figure 1-3.	Eaton 93E 60SIAC-B attached to an Eaton 93E 60 kVA UPS . . . . .	1-3
Figure 3-7.	Eaton 93E SIAC-B as Shipped on Pallet . . . . .	3-15
Figure 4-1.	Removing the Pallet Front Shipping Hardware . . . . .	4-2
Figure 4-2.	Removing the Pallet Rear Shipping Hardware . . . . .	4-3
Figure 4-3.	SIAC-B Cabinet Attaching Bracket. . . . .	4-5
Figure 4-4.	SIAC-B Attached to UPS Cabinet . . . . .	4-6
Figure 4-5.	SIAC-B Conduit Landing Wire Entry Locations . . . . .	4-9
Figure 4-6.	SIAC-B Terminal Access Plates . . . . .	4-10
Figure 4-8.	93E 30SIAC-B Bypass Input and Output Power Terminal Detail. . . . .	4-12
Figure 4-9.	93E 60SIAC-B Bypass Input and Output Power Terminal Detail. . . . .	4-13
Figure 4-11.	93E 30SIAC-B RIB Terminal Detail . . . . .	4-15
Figure 4-12.	93E 60SIAC-B RIB Terminal Detail . . . . .	4-15
Figure 4-14.	SIAC-B Interface Terminal Detail. . . . .	4-18
Figure 4-15.	Wireway Cover . . . . .	4-18
Figure 4-16.	Wireway Cover and Splice Installation . . . . .	4-19
Figure 6-1.	93E 30SIAC-B Breakers. . . . .	6-2
Figure 6-2.	93E 60SIAC-B Breakers. . . . .	6-3

This page intentionally left blank.



## List of Tables

Table 3-1.	SIAC-B Weights. . . . .	3-2
Table 3-2.	External Power Wiring Requirements for the Eaton 93E 30SIAC-B and 93E 60SIAC-B – Three Breaker Maintenance Bypass. . . . .	3-10
Table 3-3.	External Power Wiring Requirements for the Eaton 93E 30SIAC-B and 93E 60SIAC-B – Four Breaker Maintenance Bypass. . . . .	3-11
Table 3-4.	External Input Power Cable Terminations for the Eaton 93E 30SIAC-B – Three and Four Breaker Maintenance Bypass . . . . .	3-12
Table 3-5.	External Input Power Cable Terminations for the Eaton 93E 60SIAC-B – Three and Four Breaker Maintenance Bypass . . . . .	3-12
Table 4-1.	SIAC-B MBP Interface Terminals . . . . .	4-16
Table 4-2.	SIAC-B Interface Wiring Terminal Block Terminations . . . . .	4-16


This page intentionally left blank.

## Chapter 1 Introduction

The Eaton® Sidecar Integrated Accessory Cabinets (SIACs) are designed for use with the 93E 30 kVA and 60 kVA UPS. They provide maintenance bypass functions with the configurable features, enabling adaptation and expansion without costly electrical rework.

The Sidecar Integrated Accessory Cabinet-Bypass (SIAC-B) is housed in a single cabinet designed to be attached directly to the UPS cabinet. Safety shields behind the front panel provide protection from hazardous voltage. Mechanical lug input terminals reduce installation time. The cabinets match the UPS cabinet in style and color.

---

**NOTE**  Startup and operational checks must be performed by an authorized Eaton Customer Service Engineer, or the warranty terms specified on page W-1 become void. This service is offered as part of the sales contract for the UPS. Contact an Eaton service representative in advance (a minimum two-week notice is required) to reserve a preferred startup date.

---

### 1.1 Features

The following descriptions provide a brief overview of the SIACs functions:

- Three breaker configuration (used with single-feed systems) – Maintenance Bypass (MBP) and Maintenance Isolation (MIS) breakers, and a Bypass Input Breaker (BIB) enable power to completely bypass the UPS. The UPS can then be safely serviced or replaced without interrupting power to critical systems.
- Four breaker configuration (used with dual-feed systems) – Maintenance Bypass (MBP) and Maintenance Isolation (MIS) breakers, and a Bypass Input Breaker (BIB) enable power to completely bypass the UPS. A Rectifier Input Breaker (RIB) provides a convenient method for removing power from the UPS when using the maintenance bypass to supply the load. The UPS can then be safely serviced or replaced without interrupting power to critical systems.

Figure 1-1 shows the Eaton 93E 30SIAC-B and Eaton 93E 60SIAC-B.

### 1.2 Installation Features

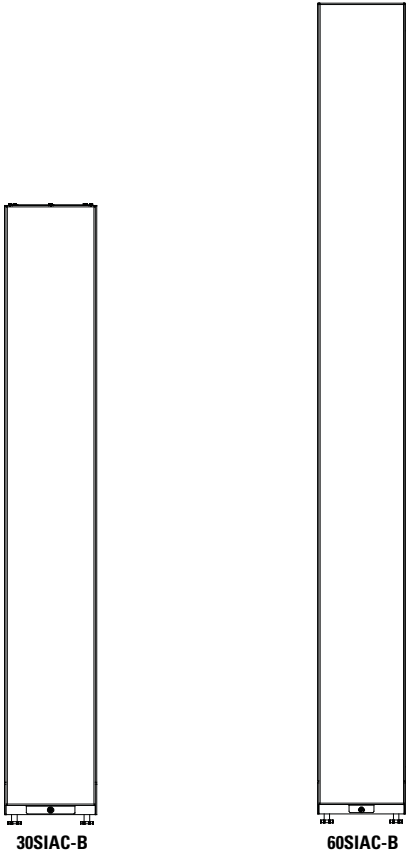
The Sidecar Integrated Accessory Cabinet-Bypass (SIAC-B) is attached to and directly integrated with the UPS cabinet and must be ordered for mounting on either the left or right side of the UPS. The SIAC-B matches the UPS cabinet in style and color. It has safety shields behind the removable front panel for hazardous voltage protection and mechanical lug input and output terminals reduce installation time. Power wiring is routed between the UPS cabinet and SIAC-B using the power terminal wiring channel assembly. Output power wiring to the critical load is routed using external conduit.

Figure 1-2 and Figure 1-3 show the SIACs mounted to the UPS cabinet.

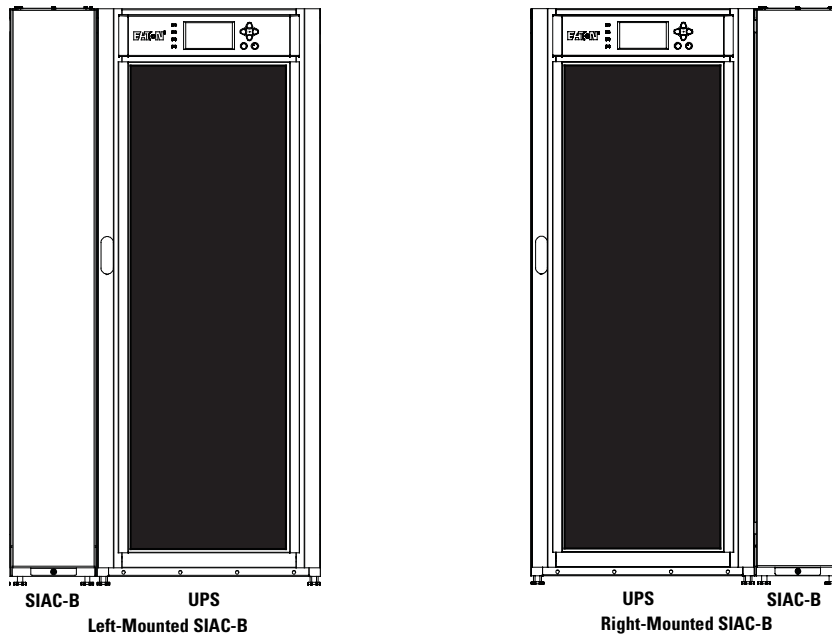
### 1.3 Model Configurations

The following model configurations are available:

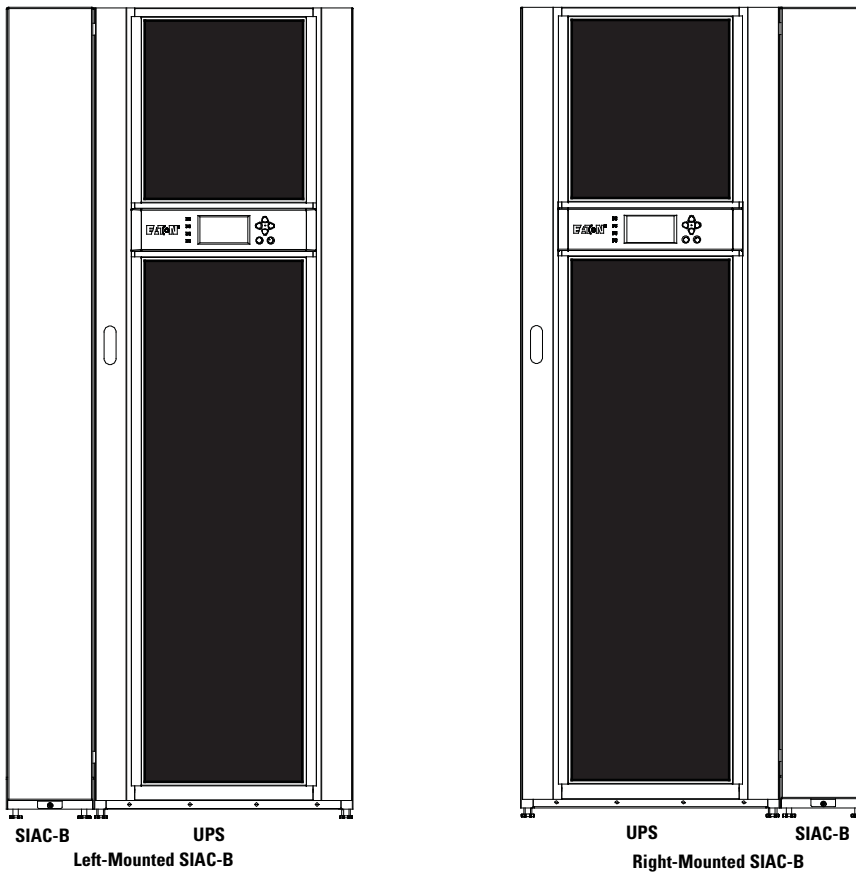
- 93E 30SIAC-B and 93E 60SIAC-B
  - Right-mounting three breaker configuration – contains a MBP with auxiliary contacts, a MIS, and a BIB
  - Right-mounting four breaker configuration – contains a MBP with auxiliary contacts, a MIS, a BIB, and a RIB
  - Left-mounting three breaker configuration – contains a MBP with auxiliary contacts, a MIS, and a BIB
  - Left-mounting four breaker configuration – contains a MBP with auxiliary contacts, a MIS, a BIB, and a RIB



**Figure 1-1. Eaton 93E 30SIAC-B and Eaton 93E 60SIAC-B**



**Figure 1-2. Eaton 93E 30SIAC-B attached to an Eaton 93E 30 kVA UPS**



**Figure 1-3. Eaton 93E 60SIAC-B attached to an Eaton 93E 60 kVA UPS**

## 1.4 Using This Manual

This manual describes how to install the SIACs and is divided into chapters. Read and understand the procedures described to ensure trouble-free installation and operation.

Read through each procedure before beginning the procedure. Perform only those procedures that apply to the UPS system being installed or operated.

## 1.5 Conventions Used in This Manual

This manual uses these type conventions:

- **Bold type** highlights important concepts in discussions, key terms in procedures, and menu options, or represents a command or option that you type or enter at a prompt.
- *Italic type* highlights notes and new terms where they are defined.
- `Screen type` represents information that appears on the screen or LCD.

Icon	Description
<b>Note</b>	Information notes call attention to important features or instructions.
[Keys]	Brackets are used when referring to a specific key, such as [Enter] or [Ctrl].

In this manual, the term UPS refers only to the UPS cabinet and its internal elements. The term UPS system refers to the entire power protection system – the UPS cabinet, an external battery system, and options or accessories installed.

The term line-up-and-match refers to accessory cabinets that are physically located adjacent to the UPS. The term standalone refers to accessory cabinets that are located separate from the UPS.

## 1.6 Symbols, Controls, and Indicators

The following are examples of symbols used on the UPS or accessories to alert you to important information:



**RISK OF ELECTRIC SHOCK** - Observe the warning associated with the risk of electric shock symbol.



**CAUTION: REFER TO OPERATOR'S MANUAL** - Refer to your operator's manual for additional information, such as important operating and maintenance instructions.



This symbol indicates that you should not discard the UPS or the UPS batteries in the trash. This product contains sealed, lead-acid batteries and must be disposed of properly. For more information, contact your local recycling/reuse or hazardous waste center.



This symbol indicates that you should not discard waste electrical or electronic equipment (WEEE) in the trash. For proper disposal, contact your local recycling/reuse or hazardous waste center.

## 1.7 For More Information

Refer to the *Eaton 93E UPS (20-30 kVA, 208/220V) Generation 3 Installation and Operation Manual* or *Eaton 93E UPS (40-60 kVA, 208/220V) Generation 3 Installation and Operation Manual* for the following additional information:

- UPS, optional components, and accessory installation instructions, including site preparation, planning for installation, and wiring and safety information. Detailed illustrations of cabinets and optional accessories with dimensional and connection point drawings are provided.
- UPS operation, including UPS controls, functions of the UPS, standard features and optional accessories, procedures for starting and stopping the UPS, and information about maintenance and responding to system events.
- Communication capabilities of the UPS system.

Refer to the *Eaton 93E Integrated Accessory Cabinet-Distribution Installation and Operation Manual* for the following additional information:

- Installation instructions, including site preparation, planning for installation, wiring and safety information, and detailed illustrations of cabinets with dimensional and connection point drawings
- Operation, including breakers, standard features and optional accessories, procedures for using the tie and bypass functions, and information about maintenance

Visit [www.eaton.com/powerquality](http://www.eaton.com/powerquality) or contact an Eaton service representative for information on how to obtain copies of these manuals.

## 1.8 Getting Help

If help is needed with any of the following:

Scheduling initial startup

Regional locations and telephone numbers

A technical question about any of the information in this manual

A question this manual does not answer

Please call the Help Desk at:

United States: **1-800-843-9433**

Canada: **1-800-461-9166 ext 260**

All other countries: **Call your local service representative**

Please use the following e-mail address for manual comments, suggestions, or to report an error in this manual:

**[E-ESSDocumentation@eaton.com](mailto:E-ESSDocumentation@eaton.com)**

This page intentionally left blank.



## Chapter 2 Safety Warnings

---

### IMPORTANT SAFETY INSTRUCTIONS SAVE THESE INSTRUCTIONS

---

This manual contains important instructions that should be followed during installation and maintenance of the UPS system and batteries. Read all instructions before operating the equipment and save this manual for future reference.

The UPS system is designed for industrial or computer room applications, and contains safety shields behind the door and front panels. However, the UPS system is a sophisticated power system and should be handled with appropriate care.

---

---

### DANGER

---

This UPS system contains LETHAL VOLTAGES. All repairs and service should be performed by AUTHORIZED SERVICE PERSONNEL ONLY. There are NO USER SERVICEABLE PARTS inside the UPS.

---

---

### WARNING

---

- The UPS system is powered by its own energy source (batteries). The output terminals may carry live voltage even when the UPS is disconnected from an AC source.
  - To reduce the risk of fire or electric shock, install this UPS system in a temperature and humidity controlled, indoor environment, free of conductive contaminants. Ambient temperature must not exceed 30°C (86°F). Do not operate near water or excessive humidity (95% maximum). The system is not intended for outdoor use.
  - As a result of the connected loads high leakage current is possible. Connection to earth ground is required for safety and proper product operation. Do not check UPS system operation by any action that includes removal of the earth (ground) connection with loads attached.
  - Ensure all power is disconnected before performing installation or service.
  - ELECTRIC ENERGY HAZARD. Do not attempt to alter any UPS system or battery wiring or connectors. Attempting to alter wiring can cause injury.
  - Failure to anchor the cabinet could lead to injury or death. To reduce this risk, the distribution, tie, and bypass cabinets must be secured to the building floor or to an adjacent 93E system cabinet.
-

---

 **CAUTION**

---

- Installation or servicing should be performed by qualified service personnel knowledgeable of UPS and battery systems, and required precautions. Keep unauthorized personnel away from equipment. Consider all warnings, cautions, and notes before installing or servicing equipment.
  - Keep the Accessory cabinet doors closed and front panels installed to ensure proper cooling airflow and to protect personnel from dangerous voltages inside the unit.
  - Do not install or operate the UPS system close to gas or electric heat sources.
  - The operating environment should be maintained within the parameters stated in this manual.
  - Keep surroundings uncluttered, clean, and free from excess moisture.
  - Observe all DANGER, CAUTION, and WARNING notices affixed to the inside and outside of the equipment.
-

# **Section 1**

# **Installation**



## Chapter 3 Installation Plan and Unpacking

This chapter includes planning and unpacking for the Sidecar Integrated Accessory Cabinet-Bypass (SIAC-B).

### Use the following basic sequence of steps to install the Eaton 93E 30SIAC-B or 93E 60SIAC-B:

1. Create an installation plan for the SIAC-B.
2. Prepare your site for the SIAC-B.
3. Inspect and unpack the SIAC-B.
4. Unload and install the SIAC-B, and wire the system.
5. Complete the Installation Checklist.
6. Have authorized service personnel perform preliminary operational checks and start up the system.



---

**NOTE** Startup and operational checks must be performed by an authorized Eaton Customer Service Engineer, or the warranty terms specified on page W-1 become void. This service is offered as part of the sales contract for the UPS. Contact an Eaton service representative in advance (usually a two-week notice is required) to reserve a preferred startup date.

---

### 3.1 Creating an Installation Plan

Before installing the SIAC-B, read and understand how this manual applies to the system being installed. Use the procedures and illustrations in this section to create a logical plan for installing the SIAC-B. This section contains the following information:

- Physical features and requirements, including dimensions
- Power wiring installation notes
- Location of conduit and wire entry landing plates
- Location of power terminals

### 3.2 Preparing the Site

For the UPS system to operate at peak efficiency, the installation site should meet the environmental parameters outlined in this manual. If the UPS system is to be operated at an altitude higher than 1500m (5000 ft), contact an Eaton service representative for important information about high altitude operation. The operating environment must meet the weight, clearance, and environmental requirements specified for the applicable accessory cabinet.

#### 3.2.1 Environmental and Installation Considerations

The UPS system installation, including the SIAC-B, must meet the following guidelines:

- The system must be installed on a level floor suitable for computer or electronic equipment.
- The system must be installed in a temperature and humidity controlled indoor area free of conductive contaminants.

Failure to follow guidelines may void your warranty.

The SIAC-B operating environment must meet the weight requirements shown in Table 3-1 and the size requirements shown in Figure 3-1 through Figure 3-5. Dimensions are in millimeters (inches).

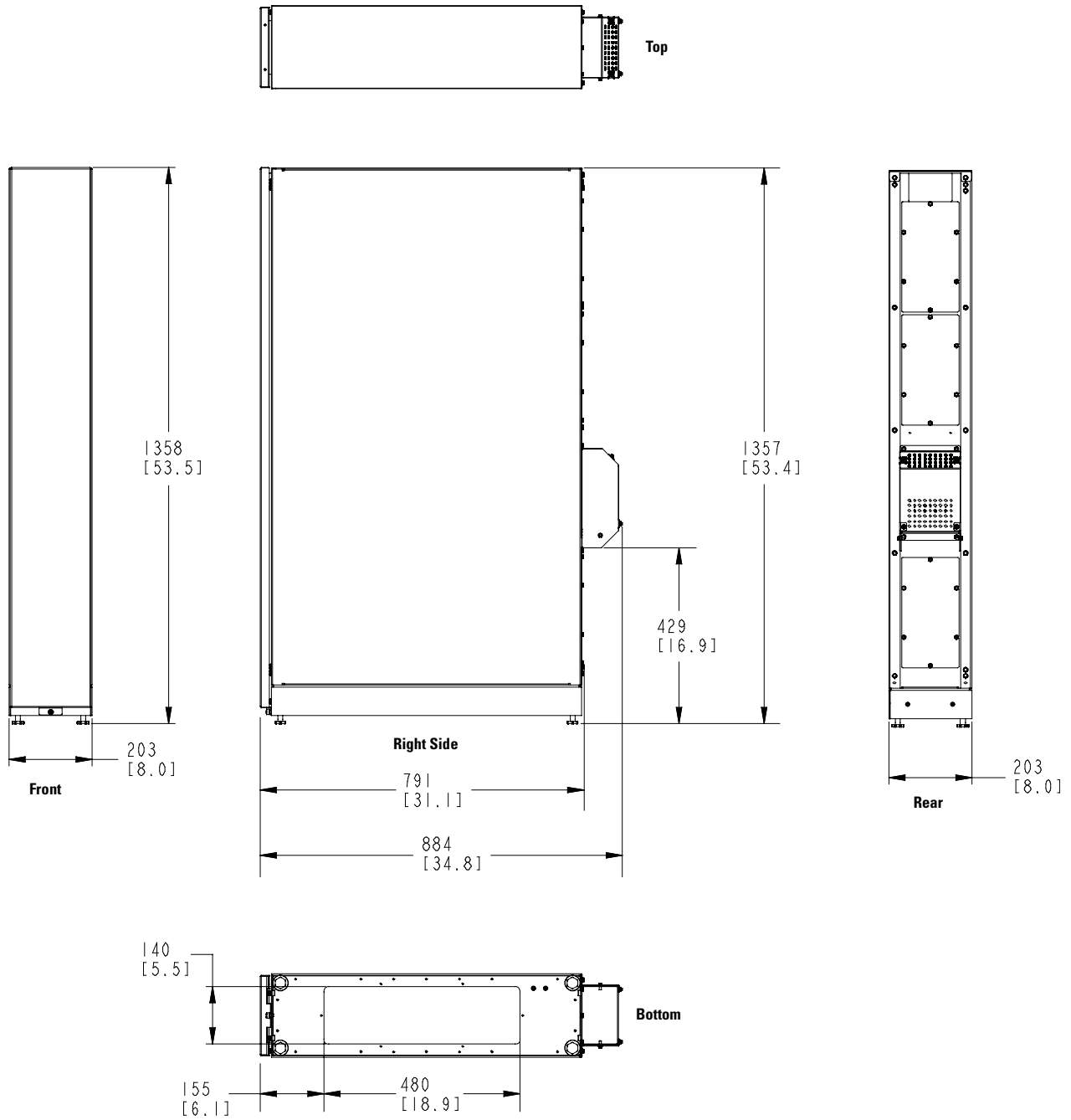
**Table 3-1. SIAC-B Weights**

Model	Shipping	Weight kg (lb)	
		Installed	Point Loading
Eaton 93E 30SIAC-B (three-breaker bypass)	98.0 (216)	75 (165)	4 at 18.8 (41.3)
Eaton 93E 30SIAC-B (four-breaker bypass)	103.9 (229)	80.9 (178)	4 at 20.2 (44.5)
Eaton 93E 60SIAC-B (three-breaker bypass)	137.4 (303)	114.4 (252)	4 at 28.6 (63.0)
Eaton 93E 60SIAC-B (four-breaker bypass)	148.8 (328)	125.8 (277)	4 at 31.5 (69.3)

The clearances required around the SIAC-B are the same as the attached UPS.

The basic environmental requirements for operation of the SIAC-Bs are:

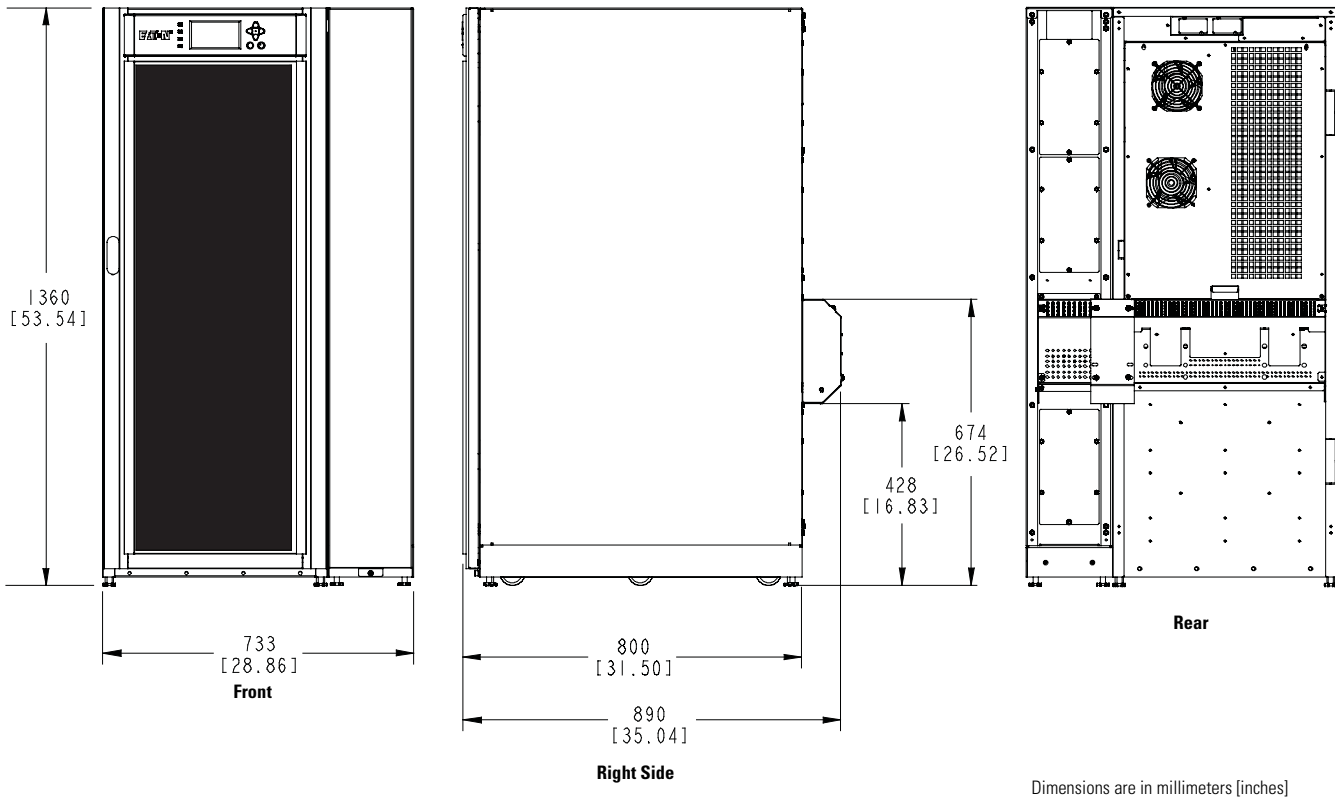
- Recommended Operating Range: 0°C to 30°C ((32°F to 86°F)
- Maximum Relative Humidity: 95%, noncondensing



Dimensions are in millimeters [inches]

**Figure 3-1. Eaton 93E 30SIAC-B Dimensions (Front, Right Side, Rear, Top, and Bottom Views)**

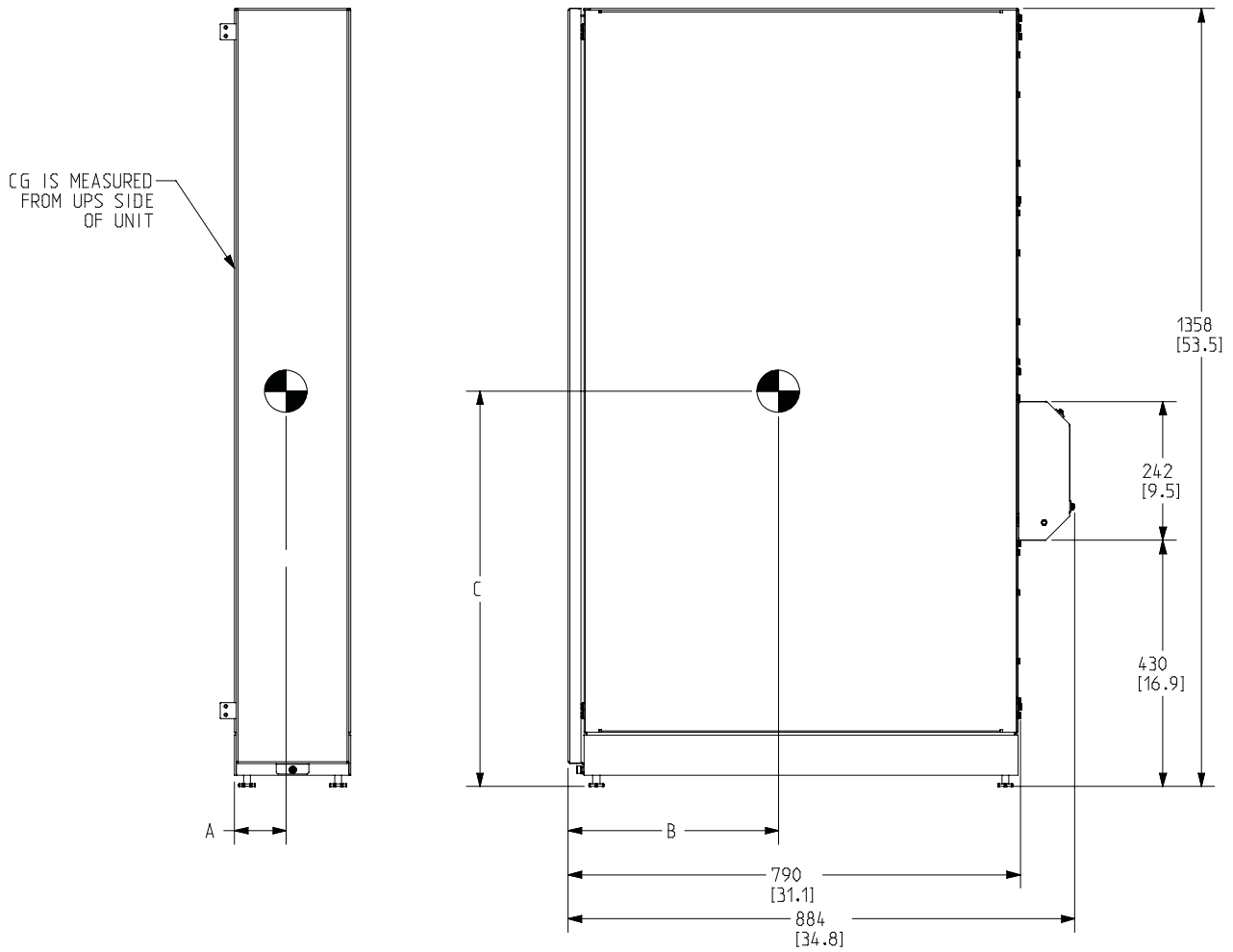
# Installation Plan and Unpacking



**NOTE** The 93E 30 kVA UPS is shown with a right-mounted SIAC-B. An UPS with a left-mounted SIAC-B is the mirror image.

**Figure 3-2. Eaton 93E 30 kVA UPS with Eaton 93E 30SIAC-B Dimensions (Front, Right Side, and Rear Views)**

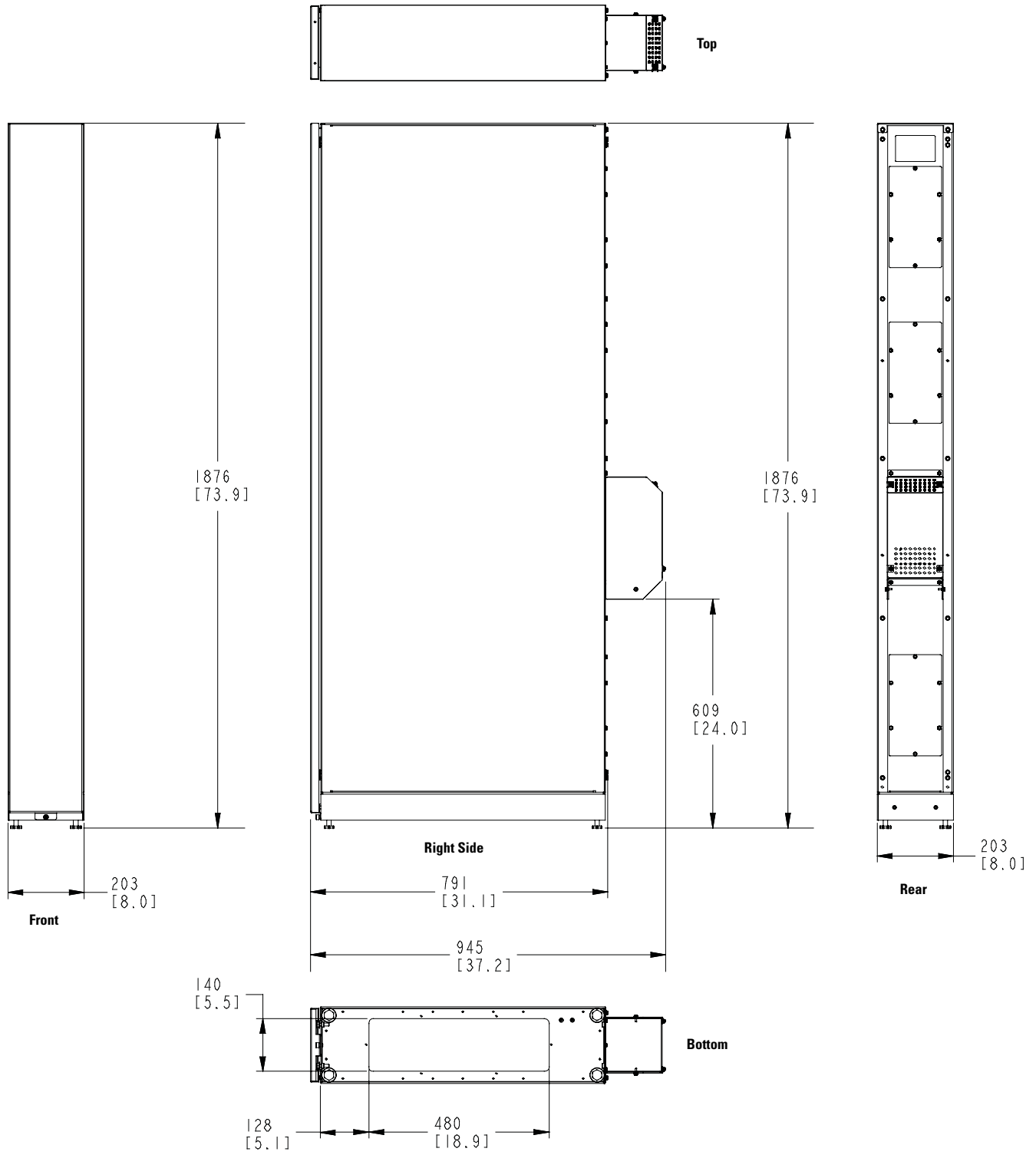




Weight and Center of Gravity				
	A	B	C	Weight kg (lb)
Eaton 93E 30SIAC-B (three-breaker bypass)	92 (3.6)	368 (14.5)	696 (27.4)	75.0 (165) – Installed
Eaton 93E 30SIAC-B (four-breaker bypass)	92 (3.6)	368 (14.5)	690 (27.2)	80.9 (178) – Installed

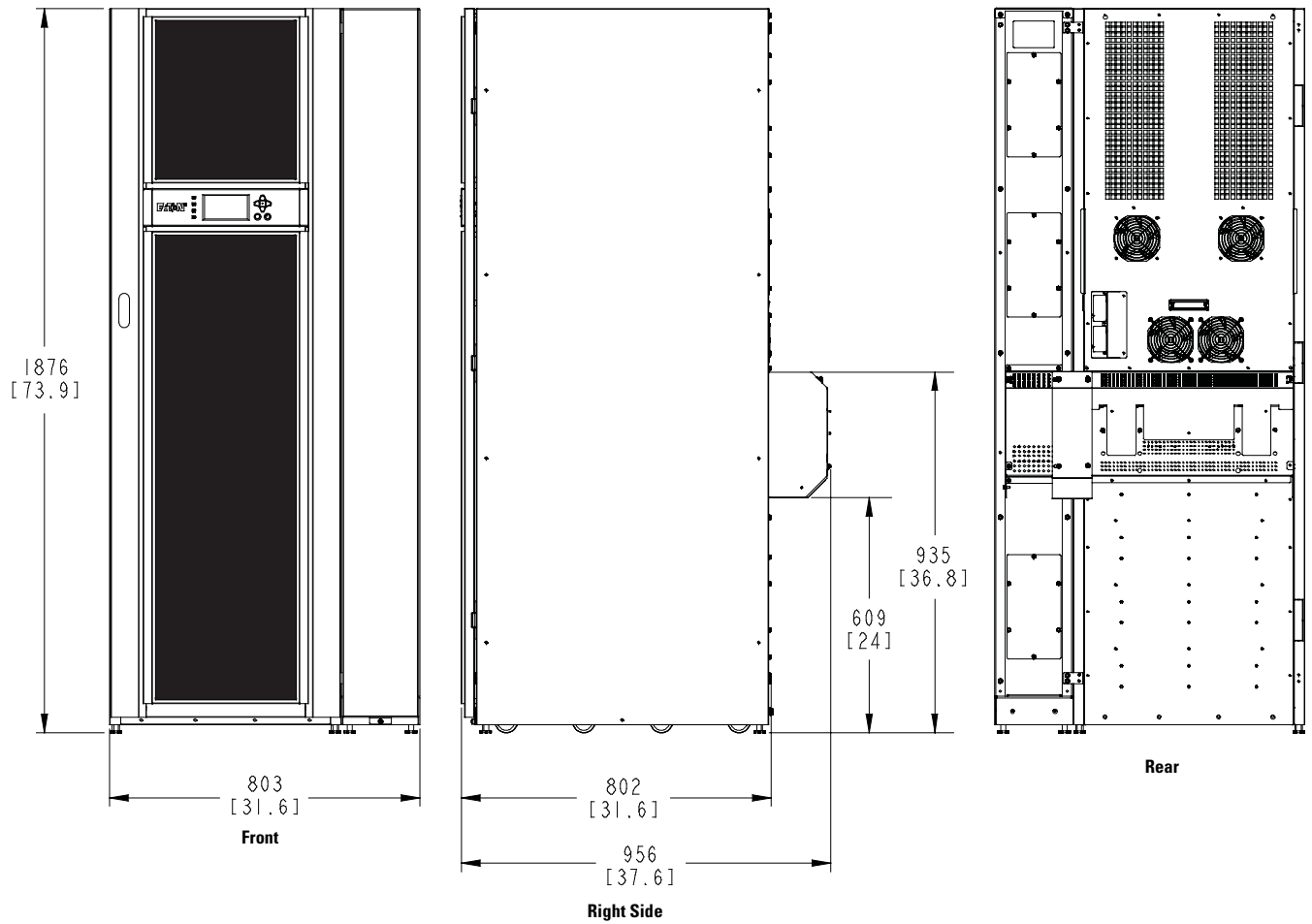
**NOTE** A right-mounted 93E 30SIAC-B is shown. A left-mounted 93E 30SIAC-B is the mirror image.

**Figure 3-3. Eaton 93E 30SIAC-B Center of Gravity**



Dimensions are in millimeters [inches]

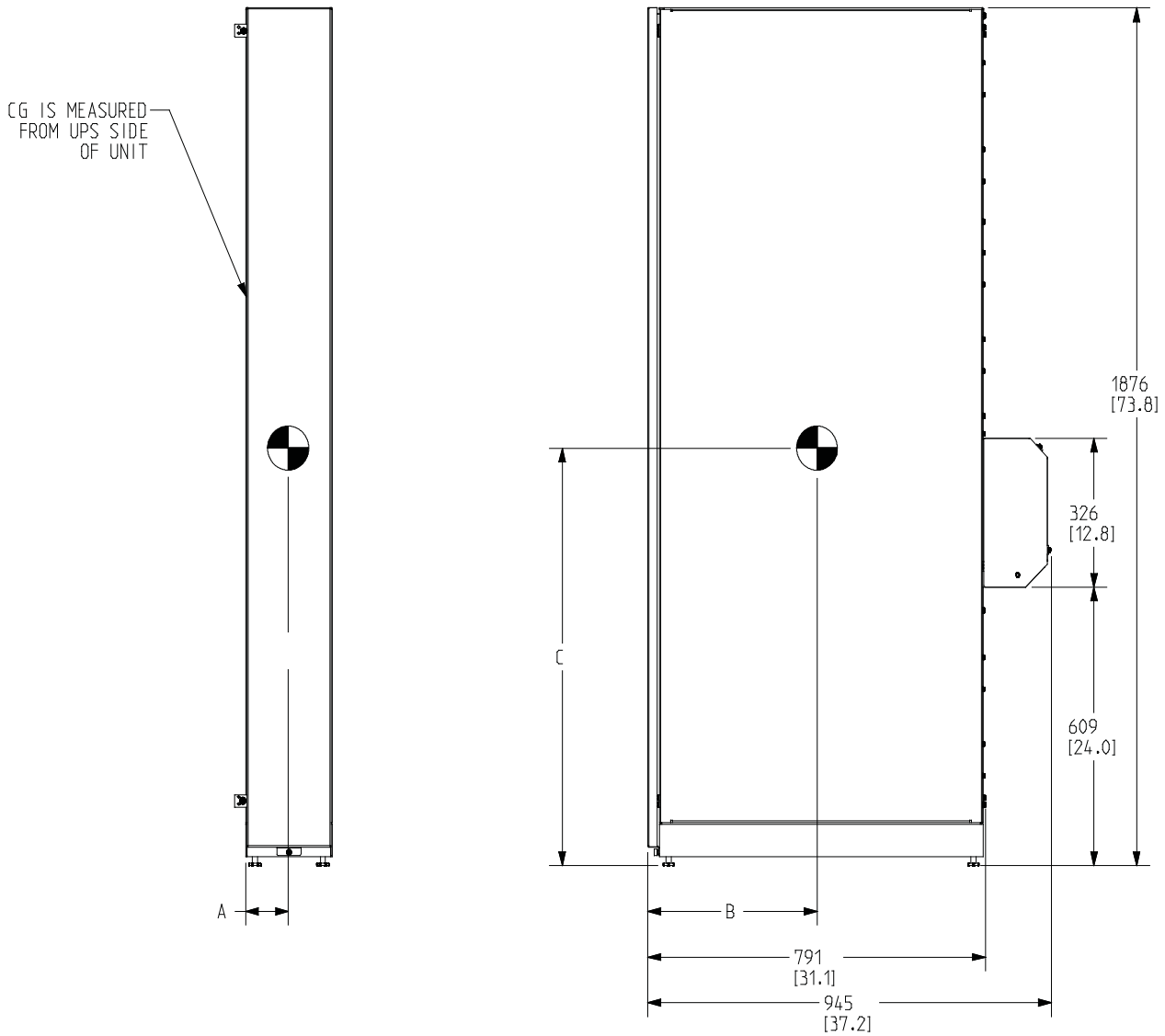
**Figure 3-4. Eaton 93E 60SIAC-B Dimensions (Front, Right Side, Rear, Top, and Bottom Views)**



**NOTE** The 93E 60 kVA UPS is shown with a right-mounted SIAC-B. An UPS with a left-mounted SIAC-B is the mirror image.

**Figure 3-5. Eaton 93E 60 kVA UPS with Eaton 93E 60SIAC-B Dimensions (Front, Right Side, and Rear Views)**

# Installation Plan and Unpacking



Weight and Center of Gravity				
	A	B	C	Weight kg (lb)
Eaton 93E 60SIAC-B (three-breaker bypass)	90 (3.5)	372 (14.7)	950 (37.4)	114.4 (252) – Installed
Eaton 93E 60SIAC-B (four-breaker bypass)	90 (3.5)	385 (15.2)	940 (37.0)	125.8 (277) – Installed

**NOTE** A right-mounted 93E 60SIAC-B is shown. A left-mounted 93E 60SIAC-B is the mirror

**Figure 3-6. Eaton 93E 60SIAC-B Center of Gravity**

### 3.2.2 SIAC-B Power Wiring Preparation

Read and understand the following notes while planning and performing the installation:

---

 **WARNING**

---

As a result of the connected loads high leakage current is possible. Connection to earth ground is required for safety and proper product operation. Do not check SIAC-B operation by any action that includes removal of the earth (ground) connection with loads attached.

---

- Refer to national and local electrical codes for acceptable external wiring practices.
- Material and labor for external wiring requirements are to be provided by the customer.
- For external wiring, use 90°C copper wire. Wire sizes listed in Table 3-3 are for copper wiring only. If wire is run in an ambient temperature greater than 30°C, higher temperature wire and/or larger size wire may be necessary. Wire sizes are based on using the specified breakers.
- Wire ampacities are chosen from Table 310-16 of the National Electrical Code® (NEC®). Specification is for copper wire with a 90°C rating.
- SIAC-B wiring for the 93E 20 kVA and 40 kVA UPS must use the 30 kVA or 60 kVA wiring requirements listed in Table 3-2 or Table 3-3 and are wired as if the UPS is fully rated at 30 kVA or 60 kVA.
- Refer to NEC Article 250 and local codes for proper grounding practices.
- Per NEC Article 300-20(a), all three-phase conductors must be run in the same conduit. Neutral and ground must be run in the same conduit as the phase conductors.
- Phase rotation must be clockwise starting with phase A (rotation A,B,C).
- Conduit is to be sized to accommodate one neutral conductor the same size as the phase conductor and one ground conductor. If two neutral conductors or an oversized neutral conductor are to be installed, size the conduit to accommodate the extra wire or size.
- Refer to the appropriate Eaton 93E UPS Installation and Operation manual listed in paragraph 1.7 for UPS cabinet conduit and terminal specifications and locations.
- The term line-up-and-match refers to accessory cabinets that are physically located adjacent to the UPS. The term standalone refers to accessory cabinets that are located separate from the UPS.

For SIAC-B external power wiring requirements, including the minimum AWG size of external wiring, see Table 3-2 or Table 3-3. Wire sizes listed are for copper wiring only.

**Table 3-2. External Power Wiring Requirements for the Eaton 93E 30SIAC-B and 93E 60SIAC-B – Three Breaker Maintenance Bypass**

Basic Unit Rating	Units	Rating 60 Hz	
Basic Unit Rating	kVA	30	60
Input/Output Voltage	Volts	208/208	208/208
<b>AC Input to Maintenance Bypass</b> (3) Phases, (1) Neutral, (1) Ground	Maximum Amps	96	185
Minimum Conductor Size (Phase A, B, and C) Number per Phase	AWG or kcmil (each)	1/0	250
		(1)	(1)
Minimum Conductor Size (Neutral) Number per Phase	AWG or kcmil (each)	1/0	250
		(2)	(2)
<b>AC Output from BIB to UPS Rectifier Input</b> (3) Phases, (1) Neutral, (1) Ground	Maximum Amps	96	185
Minimum Conductor Size (Phase A, B, and C) Number per Phase	AWG or kcmil (each)	Factory Prewired 1/0	Factory Prewired 4/0
		(1)	(1)
Minimum Conductor Size (Neutral) Number per Phase	AWG or kcmil (each)	Factory Prewired 1/0	Factory Prewired 4/0
		(1)	(1)
<b>AC Input to MIS from UPS Output</b> (3) Phases, (1) Neutral, (1) Ground	Maximum Amps	83	167
Minimum Conductor Size (Phase A, B, and C) Number per Phase	AWG or kcmil (each)	Factory Prewired 1/0	Factory Prewired 4/0
		(1)	(1)
Minimum Conductor Size (Neutral) Number per Phase	AWG or kcmil (each)	Factory Prewired 1/0	Factory Prewired 4/0
		(1)	(1)
<b>AC Output to Critical Load</b> (3) Phases, (1) Neutral, (1) Ground	Maximum Amps	83	167
Minimum Conductor Size (Phase A, B, and C) Number per Phase	AWG or kcmil (each)	1/0	250
		(1)	(1)
Minimum Conductor Size (Neutral) Number per Phase	AWG or kcmil (each)	1/0	250
		(2)	(2)
<b>Building, Load, and Inter-Cabinet Ground</b> Minimum Conductor Size (Ground) Number per Phase	AWG or kcmil (each)	#6 (1)	#2 (1)
<b>NOTE</b> Callout letters <b>A</b> , <b>B</b> , <b>C</b> , and <b>D</b> map to Figure 5-1, Figure 5-3, Figure 5-5, Figure 5-7, Figure 5-9, Figure 5-11, and Figure 5-13 (3-Breaker Version).			

**Table 3-3. External Power Wiring Requirements for the Eaton 93E 30SIAC-B and 93E 60SIAC-B – Four Breaker Maintenance Bypass**

Basic Unit Rating	Units		Rating 60 Hz	
	kVA		30	60
<b>Input/Output Voltage</b>	Volts		208/208	208/208
<b>AC Input to Maintenance Bypass</b> (3) Phases, (1) Neutral, (1) Ground	<b>A</b>	Maximum Amps	83	167
Minimum Conductor Size (Phase A, B, and C) Number per Phase		AWG or kcmil (each)	1/0 (1)	250 (1)
Minimum Conductor Size (Neutral) Number per Phase		—	AWG or kcmil (each)	1/0 (2)
<b>AC Input to RIB</b> (3) Phases, (1) Neutral, (1) Ground	<b>B</b>	Maximum Amps	96	185
Minimum Conductor Size (Phase A, B, and C) Number per Phase		AWG or kcmil (each)	1/0 (1)	250 (1)
Minimum Conductor Size (Neutral) Number per Phase		—	AWG or kcmil (each)	1/0 (2)
<b>AC Output from RIB to UPS Rectifier Input</b> (3) Phases, (1) Neutral, (1) Ground	<b>C</b>	Maximum Amps	96	185
Minimum Conductor Size (Phase A, B, and C) Number per Phase		AWG or kcmil (each)	Factory Prewired 1/0 (1)	Factory Prewired 4/0 (1)
Minimum Conductor Size (Neutral) Number per Phase		—	AWG or kcmil (each)	Factory Prewired 1/0 (1)
<b>AC Output from BIB to UPS Bypass Input</b> (3) Phases, (1) Neutral, (1) Ground	<b>D</b>	Maximum Amps	83	167
Minimum Conductor Size (Phase A, B, and C) Number per Phase		AWG or kcmil (each)	Factory Prewired 1/0 (1)	Factory Prewired 4/0 (1)
Minimum Conductor Size (Neutral) Number per Phase		—	AWG or kcmil (each)	Factory Prewired 1/0 (1)
<b>AC Input to MIS from UPS Output</b> (3) Phases, (1) Neutral, (1) Ground	<b>E</b>	Maximum Amps	83	167
Minimum Conductor Size (Phase A, B, and C) Number per Phase		AWG or kcmil (each)	Factory Prewired 1/0 (1)	Factory Prewired 4/0 (1)
Minimum Conductor Size (Neutral) Number per Phase		—	AWG or kcmil (each)	Factory Prewired 1/0 (1)
<b>AC Output to Critical Load</b> (3) Phases, (1) Neutral, (1) Ground	<b>F</b>	Maximum Amps	83	167
Minimum Conductor Size (Phase A, B, and C) Number per Phase		AWG or kcmil (each)	1/0 (1)	250 (1)
Minimum Conductor Size (Neutral) Number per Phase		—	AWG or kcmil (each)	1/0 (2)
<b>Building, Load, and Inter-Cabinet Ground</b> Minimum Conductor Size (Ground) Number per Phase	—	AWG or kcmil (each)	#6 (1)	#2 (1)
<b>NOTE</b> Callout letters <b>A, B, C, D, E, and F</b> map to Figure 5-2, Figure 5-4, Figure 5-6, Figure 5-8, Figure 5-10, Figure 5-12, and Figure 5-14 (4-Breaker Version).				

## Installation Plan and Unpacking

The power wiring terminals are pressure terminations, UL and CSA rated at 90°C. See Table 3-4 or Table 3-5 for SIAC-B external input power cable terminations.

Figure 4-7 and Figure 4-10 show the location of the SIAC-B power cable terminals.

**Table 3-4. External Input Power Cable Terminations for the Eaton 93E 30SIAC-B – Three and Four Breaker Maintenance Bypass**

Terminal Function	Terminal	Function	Number and Size of Pressure	Tightening Torque	Size Screw and Type
			Termination (AWG or kcmil)	Nm (lb in)	
AC Input to RIB (4-breaker version only)	E1 (RIB-2)	Phase A	1 – #14-3/0	5.6 (50)	Slotted
	E2 (RIB-4)	Phase B	1 – #14-3/0	5.6 (50)	Slotted
	E3 (RIB-6)	Phase C	1 – #14-3/0	5.6 (50)	Slotted
	N	Neutral	2 – #6-300	31 (275)	5/16" Hex
AC Input to Maintenance Bypass	E6	Phase A	1 – #6-250	31 (275)	1/4" Hex
	E7	Phase B	1 – #6-250	31 (275)	1/4" Hex
	E8	Phase C	1 – #6-250	31 (275)	1/4" Hex
	N	Neutral	2 – #6-300	31 (275)	5/16" Hex
AC Output to Critical Load	E9	Phase A	1 – #6-250	31 (275)	1/4" Hex
	E10	Phase B	1 – #6-250	31 (275)	1/4" Hex
	E11	Phase C	1 – #6-250	31 (275)	1/4" Hex
	N	Neutral	2 – #6-300	31 (275)	5/16" Hex
Load and Inter-Cabinet Ground	G	Ground	4 – #14-1/0	5.6 (50)	Slotted

**Table 3-5. External Input Power Cable Terminations for the Eaton 93E 60SIAC-B – Three and Four Breaker Maintenance Bypass**

Terminal Function	Terminal	Function	Number and Size of Pressure	Tightening Torque	Size Screw and Type
			Termination (AWG or kcmil)	Nm (lb in)	
AC Input to RIB (4-breaker version only)	E1 (RIB-2)	Phase A	1 – #4-350	20 (177)	5/16" Hex
	E2 (RIB-4)	Phase B	1 – #4-350	20 (177)	5/16" Hex
	E3 (RIB-6)	Phase C	1 – #4-350	20 (177)	5/16" Hex
	N	Neutral	2 – #6-300	31 (275)	5/16" Hex
AC Input to Maintenance Bypass	E6	Phase A	1 – #6-500	56.5 (500)	1/2" Hex
	E7	Phase B	1 – #6-500	56.5 (500)	1/2" Hex
	E8	Phase C	1 – #6-500	56.5 (500)	1/2" Hex
	N	Neutral	2 – #6-300	31 (275)	5/16" Hex
AC Output to Critical Load	E9	Phase A	1 – #6-500	56.5 (500)	1/2" Hex
	E10	Phase B	1 – #6-500	56.5 (500)	1/2" Hex
	E11	Phase C	1 – #6-500	56.5 (500)	1/2" Hex
	N	Neutral	2 – #6-300	31 (275)	5/16" Hex
Load and Inter-Cabinet Ground	G	Ground	4 – #14-1/0	5.6 (50)	Slotted



### 3.2.3 SIAC-B Interface Wiring Preparation

Control wiring for features and options should be connected at the customer interface terminal block located inside the SIAC-B.



#### **WARNING**

---

Do not directly connect relay contacts to the mains related circuits. Reinforced insulation to the mains is required.

---


Read and understand the following notes while planning and performing the installation:

- Use Class 1 wiring methods (as defined by the NEC) for interface wiring from 30V to 600V. The wire should be rated for 600V, 1A minimum. 12 AWG maximum wire size.
- Use Class 2 wiring methods (as defined by the NEC) for interface wiring up to 30V. The wire should be rated for 24V, 1A minimum.
- Use twisted-pair wires for each input and return or common.
- All interface wiring and conduit is to be supplied by the customer.
- Interface wiring can be installed using conduit between cabinets or by routing wiring through the power terminal cover base wiring channels.
- Install the interface wiring in separate conduit from the power wiring.

## 3.3 Inspecting and Unpacking the SIAC-B

The cabinet is shipped bolted to a wooden pallet and covered with outer protective packaging material (see Figure 3-7).

---

 **NOTE** Startup and operational checks must be performed by an authorized Eaton Customer Service Engineer, or the warranty terms specified on page W-1 become void. This service is offered as part of the sales contract for the UPS. Contact an Eaton service representative in advance (usually a two-week notice is required) to reserve a preferred startup date.

---

---

 **WARNING**

---

The SIAC-B is heavy (see Table 3-1). If unpacking and unloading instructions are not closely followed, the cabinet may tip and cause serious injury.

---

1. Carefully inspect the outer packaging for evidence of damage during transit.
- 

---


 **CAUTION**

---

Do not install a damaged cabinet. Report any damage to the carrier and contact an Eaton service representative immediately.

---

---

 **NOTE** For the following step, verify that the forklift or pallet jack is rated to handle the weight of the cabinet (see Table 3-1 for cabinet weight).

---

2. Use a forklift or pallet jack to move the packaged cabinet to the installation site, or as close as possible, before unpacking. If possible, move the cabinet using the pallet. Insert the forklift or pallet jack forks between the supports on the bottom of the pallet (see Figure 3-3 or Figure 3-6 for the SIAC-B center of gravity measurements).
- 

---


 **CAUTION**

---

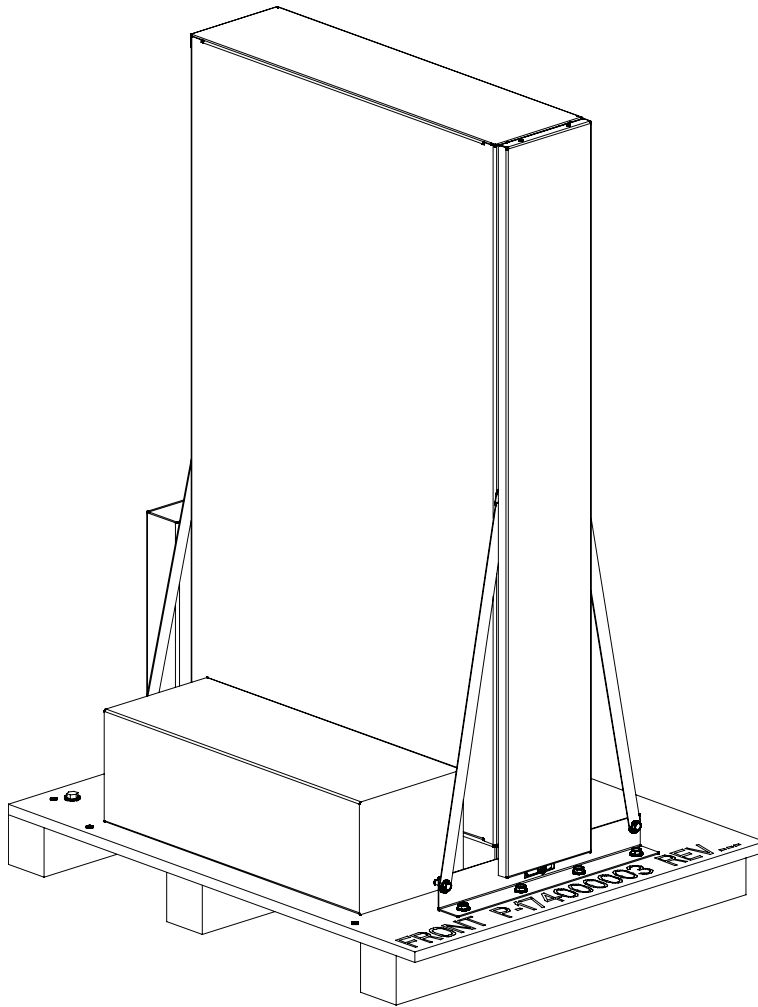
Do not tilt the SIAC-B more than 10° from vertical or the cabinets may tip over (see Figure 3-3 or Figure 3-6 for the SIAC-B center of gravity measurements).

---

3. Set the pallet on a firm, level surface, allowing a minimum clearance of 3m (10 ft) on each side for removing the cabinet from the pallet.
  4. Remove the protective packaging material from the cabinet and recycle in a responsible manner. Retain the parts kit box packed at the side of the cabinet and leave the cables in the cardboard sleeve until electrical installation.
  5. Inspect the contents for any evidence of physical damage, and compare each item with the Bill of Lading. If damage has occurred or shortages are evident, contact an Eaton service representative immediately to determine the extent of the damage and its impact on further installation.
- 

 **NOTE** While waiting for installation, protect the unpacked cabinet from moisture, dust, and other harmful contaminants. Failure to store and protect the SIAC-B properly may void your warranty.

---



**NOTE** The 93E 30SIAC-B is shown. The 93E 60SIAC-B is shipped using the same type of pallet.

**Figure 3-7. Eaton 93E SIAC-B as Shipped on Pallet**

This page intentionally left blank.

## Chapter 4 Installation

This chapter includes unloading and installing instructions for the Sidecar Integrated Accessory Cabinet-Bypass (SIAC-B).

### 4.1 Preliminary Installation Information

---

** WARNING**

---

Installation should be performed only by qualified personnel knowledgeable of batteries and the required precautions.

---

Refer to the following while installing the SIAC-B:

- Chapter 3 for cabinet dimensions, equipment weight, wiring and terminal data, and installation notes.
- Do not tilt the cabinets more than  $\pm 10^\circ$  during installation. See Figure 3-3 or Figure 3-6 for the SIAC-B center of gravity measurements.

### 4.2 Unloading the SIAC-B from the Pallet and Mechanical Installation

The Sidecar Integrated Accessory Cabinet-Bypass (SIAC-B) is bolted to wood skids using angle brackets and side braces.

---

** WARNING**

---

The SIAC-B is heavy (see Table 3-1) and bulky. Two persons are required to lift the cabinet from the pallet and place the cabinet in position adjacent to the UPS cabinet. If unpacking and unloading instructions are not closely followed serious injury may occur.

---

---

** CAUTION**

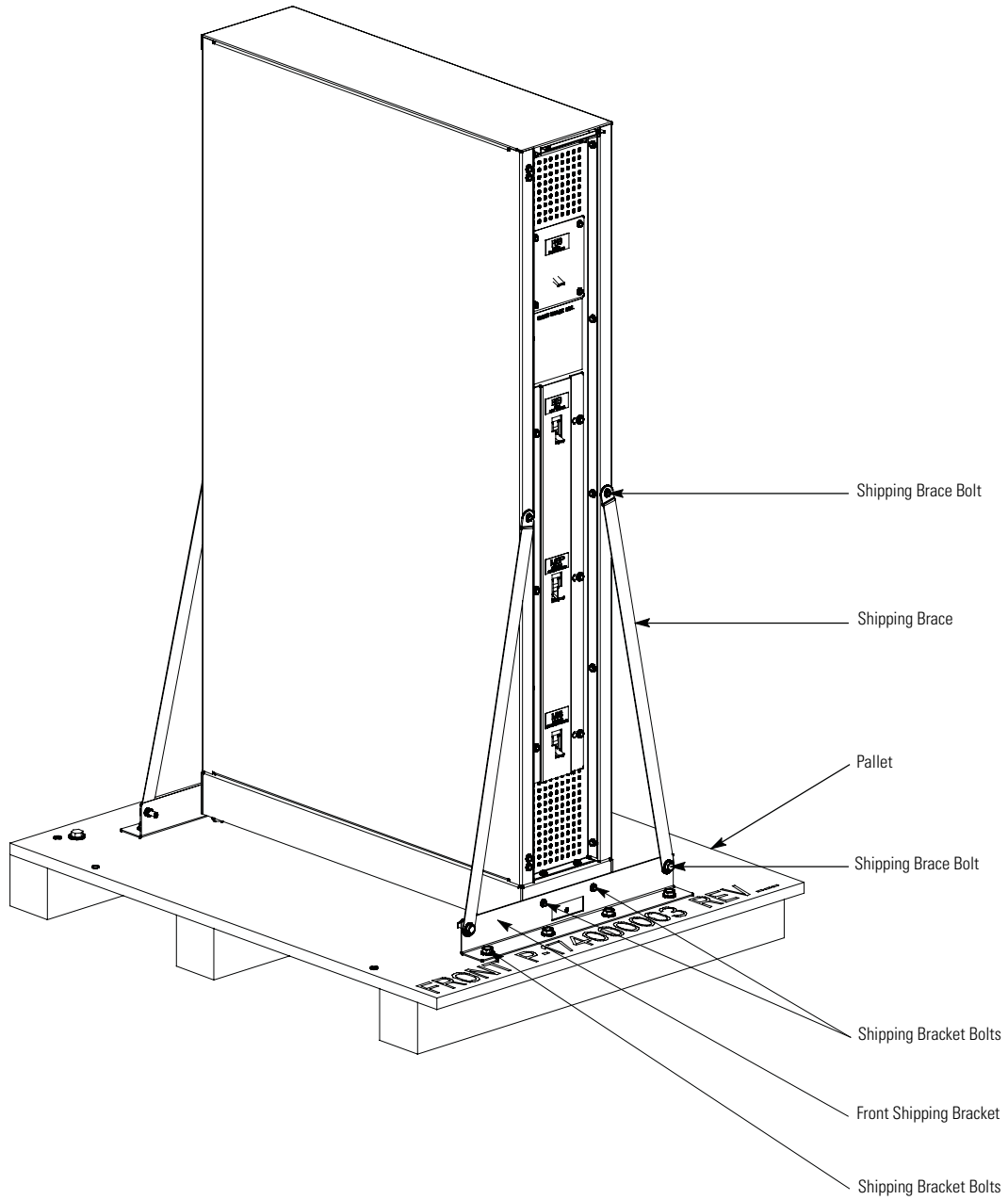
---

Lift the palletted cabinet only with a forklift or damage may occur.

---

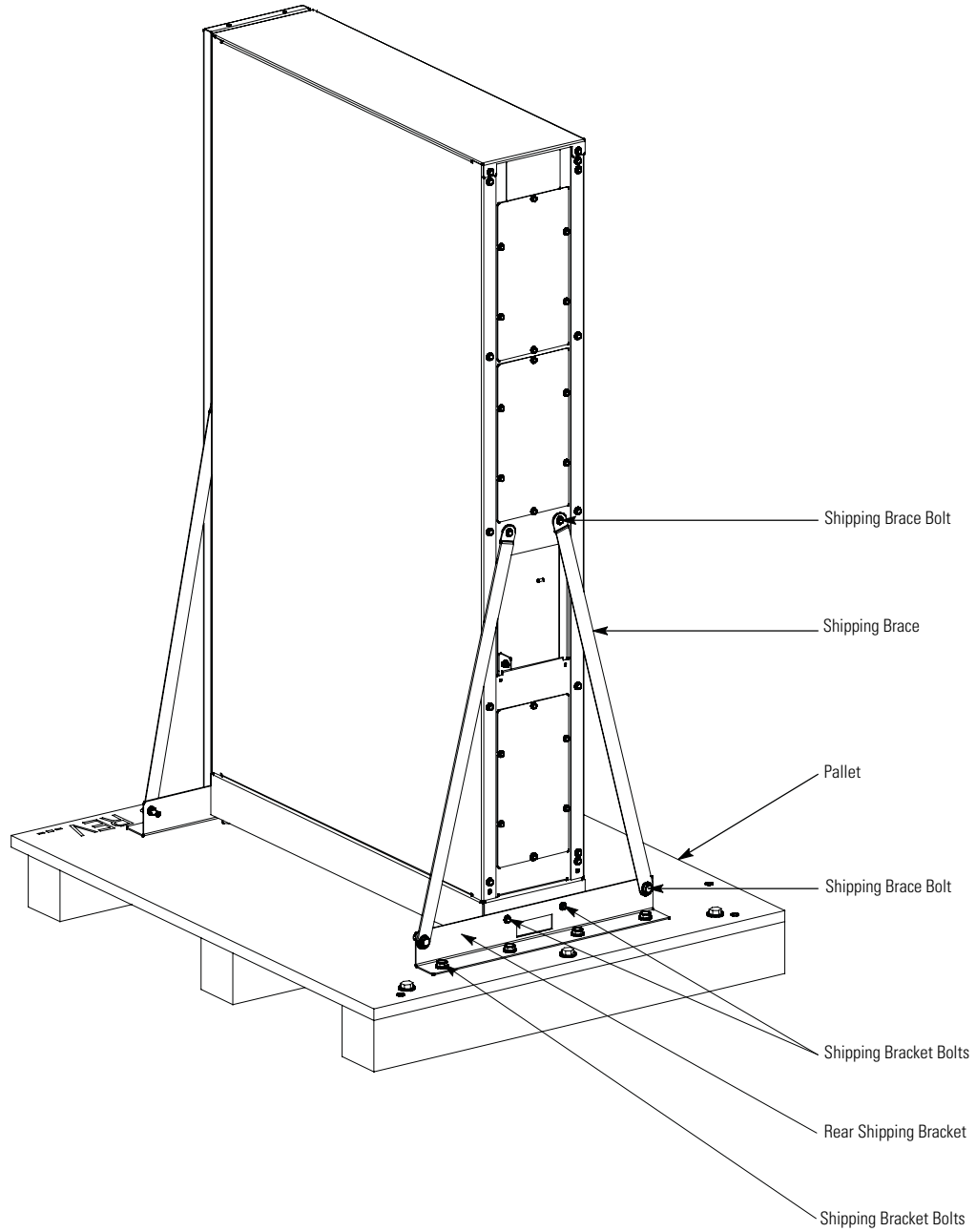
To remove the pallet and install the SIAC-B:

1. If not already accomplished, use a forklift or pallet jack to move the SIAC-B to the installation area, or as close as possible, before unloading from the pallet. Insert the forklift or pallet jack forks between the supports on the bottom of the pallet (see Figure 3-3 or Figure 3-6 for the SIAC-B center of gravity measurements).
2. Loosen the captive thumb screw securing the bottom of the SIAC-B front panel. Lift the panel straight up to remove it from the panel hanger bracket at the top of the cabinet.
3. If the leveling feet are not fully retracted, turn all four leveling feet until they are retracted into the cabinet.
4. Remove four bolts securing the front shipping bracket to the pallet (see Figure 4-1).
5. Remove four bolts securing the rear shipping bracket to the pallet (see Figure 4-2).



**NOTE** The 93E 30SIAC-Bis shown. The 93E 60SIAC-B pallet is removed using the same method.

**Figure 4-1. Removing the Pallet Front Shipping Hardware**




**NOTE** The 93E 30SIAC-Bis shown. The 93E 60SIAC-B pallet is removed using the same

**Figure 4-2. Removing the Pallet Rear Shipping Hardware**

---

**NOTE 1** The SIAC-B is available for left mounting or right mounting. A left-mounted SIAC-B is installed on the left side of the UPS. A right-mounted SIAC-B is installed on the right side of the UPS. When installed correctly, the unpainted side of the SIAC-B will face the side of the UPS cabinet.


 **NOTE 2** The SIAC-B has pre-wired cables for connection to the UPS. The cables are coiled inside of a cardboard sleeve at the back of the SIAC-B. If possible, leave the cables in the sleeve during the mechanical installation.

**NOTE 3** Leave the front and rear shipping brackets and braces attached to the cabinet during removal from the pallet for increased stability.

---

6. Using two persons, remove the SIAC-B from the pallet by walking or sliding the cabinet from the pallet. Position the cabinet adjacent to the correct side of the UPS cabinet (see Note 1).
7. Remove the shipping brace bolts securing the front left and right shipping braces to the cabinet (see Figure 4-1).
8. Remove the bolts securing the front left and right shipping braces to the shipping brackets (see Figure 4-1). Remove the braces.
9. Remove the bolts securing the back left and right shipping braces to the cabinet (see Figure 4-2).
10. Remove the bolts securing the back left and right shipping braces to the shipping brackets (see Figure 4-2). Remove the braces.
11. Remove two bolts securing the front shipping bracket to the cabinet (see Figure 4-1). Remove the front shipping bracket.
12. Remove two bolts securing the rear shipping bracket to the cabinet (see Figure 4-2). Remove the rear shipping bracket.

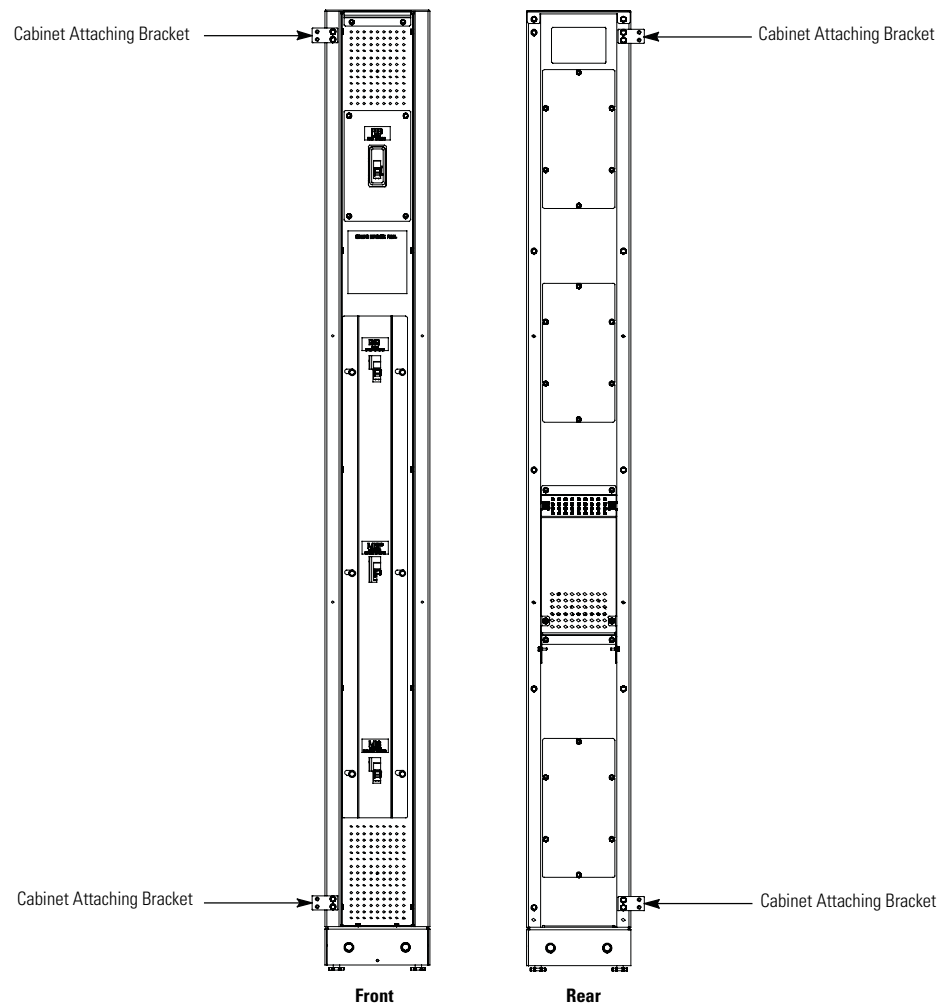
---

 **NOTE** Use the leveling feet to align and support the SIAC-B.

---

13. Align the SIAC-B with the UPS using the leveling feet.
14. Remove the screws securing four cabinet attaching brackets (see Figure 4-3) to the SIAC-B. Remove the brackets.
15. Rotate the brackets and reinstall the brackets to the SIAC-B. See Figure 4-3 for correct orientation.
16. Locate the parts bag with the cabinet attaching bracket screws. The parts bag is packed with the SIAC-B manual at the bottom rear of the SIAC-B.
17. Secure the SIAC-B to the UPS cabinet using two screws from the parts bag for each bracket. Use the existing UPS screw holes. If necessary, use the leveling feet to align the bracket holes with the UPS screw holes. See Figure 4-4 for attached view.
18. Reinstall the SIAC-B front panel and secure with captive thumb screw.
19. Recycle the SIAC-B pallet and shipping brackets in a responsible manner.
20. Proceed to paragraph 4.3.

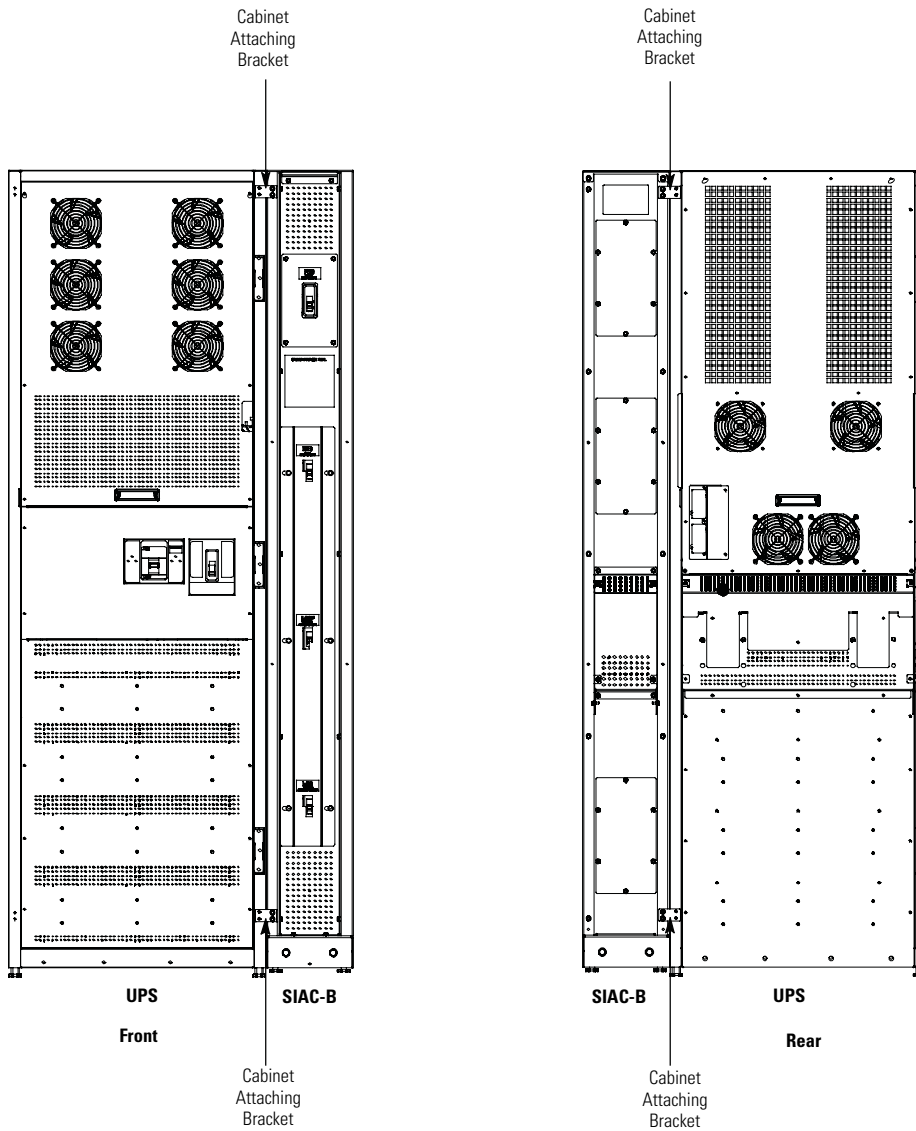




**NOTE 1** The 93E 60SIAC-Bis shown. The 93E 30SIAC-B uses the same brackets.

**NOTE 2** A right-mounted SIAC-B is shown. A left-mounted SIAC-B is the mirror image.

**Figure 4-3. SIAC-B Cabinet Attaching Bracket**



**NOTE 1** The 93E 60SIAC-B is shown. The 93E 30SIAC-B is attached using the same method.

**NOTE 2** A right-mounted SIAC-B is shown. A left-mounted SIAC-B is the mirror image.

**Figure 4-4. SIAC-B Attached to UPS Cabinet**

### 4.3 Installing the SIAC-B Prewired Cables

---

**NOTE 1** The SIAC-B Bypass Input Breaker (BIB) to UPS, UPS Output, and Rectifier Input Breaker (RIB) to UPS (if installed) phase and neutral wiring are prewired to the SIAC-B.



**NOTE 2** Power wiring is installed by routing wiring through the UPS power terminal cover base wiring channel.

---

To install wiring:

1. Verify the UPS system is turned off and all power sources are removed. Refer to the applicable Eaton 93E UPS Installation and Operation manual listed in paragraph 1.7, for UPS operating procedures.
2. If not already installed, install the power terminal cover base to the UPS. Refer to the applicable Eaton 93E UPS Installation and Operation manual listed in paragraph 1.7 for UPS installation procedures.
3. Locate the wiring sleeve at the back of the SIAC-B. Remove the bundled cables from the sleeve and recycle the sleeve in a responsible manner.
4. Route the wires to the UPS power terminal cover base wiring channel. Refer to the applicable Eaton 93E UPS Installation and Operation manual listed in paragraph 1.7 for wiring channel location.
5. Connect the BIB to UPS, UPS Output, and RIB to UPS (if installed) phase and neutral wiring from the SIAC-B to the UPS power terminals. Follow the cable, phase, and neutral designations marked on the cables to connect the cables to the correct terminals. Refer to the applicable Eaton 93E UPS Installation and Operation manual listed in paragraph 1.7, for UPS cabinet terminal locations, termination requirements, and installation instructions.
6. Proceed to paragraph 4.4.

### 4.4 Installing SIAC-B External Power Wiring

---

**NOTE 1** External power wiring can be routed either through the top or bottom of the SIAC-B.



**NOTE 2** Remove the SIAC-B top cover or bottom conduit landing plate to drill or punch conduit holes (see Figure 4-5).

**NOTE 3** Depending on installation constraints, the SIAC-B outside side panel and the top cover can be removed to assist in routing wiring to SIAC-B terminals.

---

To install wiring:

1. Remove the screws securing the terminal block access plates (see Figure 4-6) and remove the plates to gain access to the bypass input, neutral, output, and ground terminals. Retain the plates and hardware for later use.
2. If an RIB is installed, proceed to Step 3; otherwise, proceed to Step 5.
3. Loosen the captive thumb screw securing the bottom of the SIAC-B front panel. Lift the panel straight up to remove it from the panel hanger bracket at the top of the cabinet.
4. At the front of the SIAC-B, remove the four screws securing the RIB front access cover plate to gain access to the RIB input terminal termination screws. Retain the hardware for later use.
5. If wiring the SIAC-B using top entry wiring access, proceed to Step 6; otherwise, proceed to Step 9.
6. **Top Entry Wiring.** Remove the top cover (see Figure 4-5) from the top of the SIAC-B. Identify all conduit requirements and mark their location. Drill and punch all conduit holes in the top cover prior to mounting on the SIAC-B. Install the top cover and install all conduit runs into the top cover.

---

**NOTE** In the following step, remove or slide back the SIAC-B top cover to gain access to the RIB input terminals or if accessible, remove the SIAC-B outside side panel.

---

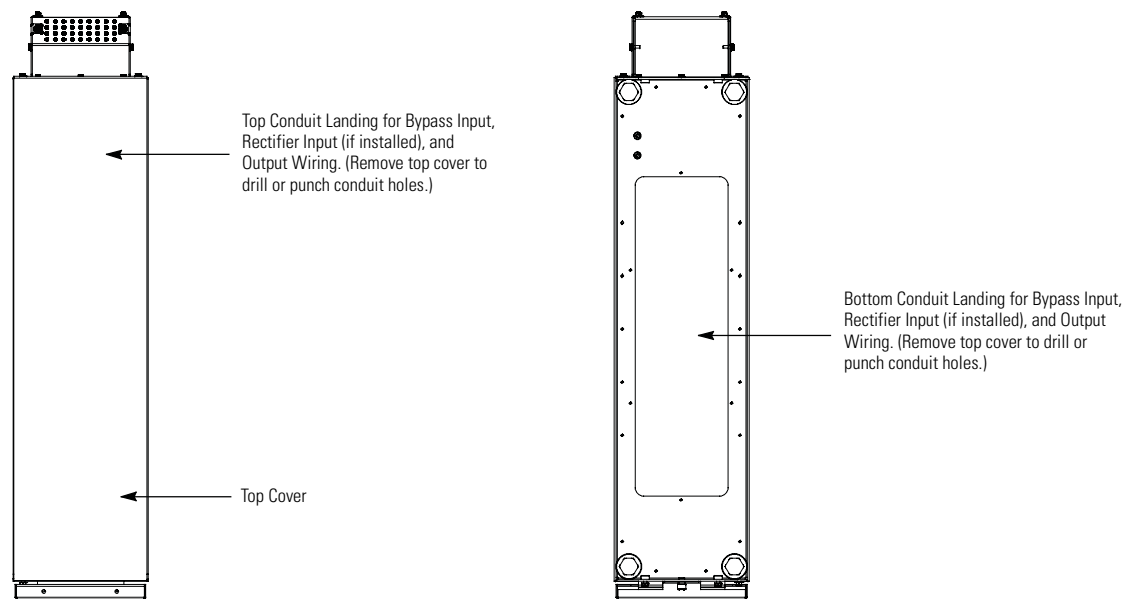
7. Route the maintenance bypass input, critical load output, and rectifier input (if installed) cables (phase A, B, and C, Neutral, and Ground) through the conduit on the top of the SIAC-B to the SIAC-B terminals. See Figure 4-5 and Figure 4-6 for SIAC-B wiring access information, and Figure 4-7 through Figure 4-12 for terminal locations.
8. Proceed to Step 11.
9. **Bottom Entry Wiring.** Remove the bottom conduit plate (see Figure 4-5) from the bottom of the SIAC-B. Identify all conduit requirements and mark their location. Drill and punch all conduit holes in the bottom conduit plate prior to mounting on the SIAC-B. Install the conduit plate and install all conduit runs into the plate.

---

**NOTE** In the following step, remove or slide back the SIAC-B top cover to gain access to the RIB input terminals or if accessible, remove the SIAC-B outside side panel.

---

10. Route the maintenance bypass input, critical load output, and rectifier input (if installed) cables (phase A, B, and C, Neutral, and Ground) through the conduit on the bottom of the SIAC-B to the SIAC-B terminals. See Figure 4-5 and Figure 4-6 for SIAC-B wiring access information, and Figure 4-7 through Figure 4-12 for terminal locations.
11. Connect phase A, B, and C, Neutral, and Ground bypass input power wiring from the utility source to the SIAC-B maintenance bypass input terminals. See paragraph 3.2.2, Table 3-2 or Table 3-3 and Table 3-4 or Table 3-5 for SIAC-B wiring and termination requirements.  
  
For a detailed view of the SIAC-B terminal blocks, see Figure 4-8 or Figure 4-9.
12. Connect phase A, B, and C, Neutral, and Ground output power wiring from the SIAC-B output terminals to the critical load or Integrated Accessory Cabinet-Distribution (IAC-D). See paragraph 3.2.2, Table 3-2 or Table 3-3 and Table 3-4 or Table 3-5 for SIAC-B wiring and termination requirements. Refer to the *Eaton 93E Integrated Accessory Cabinet-Distribution Installation and Operation Manual* listed in paragraph 1.7 for conduit and terminal locations and termination requirements.  
  
For a detailed view of the SIAC-B terminal blocks, see Figure 4-8 or Figure 4-9.
13. If installed, connect phase A, B, and C, Neutral, and Ground rectifier input power wiring from the utility source to the SIAC-B rectifier input terminals. See paragraph 3.2.2, Table 3-3, and Table 3-5 for SIAC-B wiring and termination requirements.  
  
For a detailed view of the SIAC-B terminal blocks, see Figure 4-11 or Figure 4-12.
14. Route and connect ground wiring between the SIAC-B and the UPS cabinet ground terminals.
15. Reinstall the RIB front access cover plate removed in Step 4.
16. If removed, reinstall the top cover and outside side panel.
17. Reinstall the SIAC-B front panel and secure with captive thumb screw.
18. Reinstall the terminal block access plates removed in Step 1.
19. Proceed to paragraph 4.5.



**NOTE** To remove the SIAC-B top cover:

- Remove two screws at the back of the cover
- Slide the cover towards the rear of the cabinet approximately 1/2"
- Lift the cover up and remove

**Figure 4-5. SIAC-B Conduit Landing Wire Entry Locations**

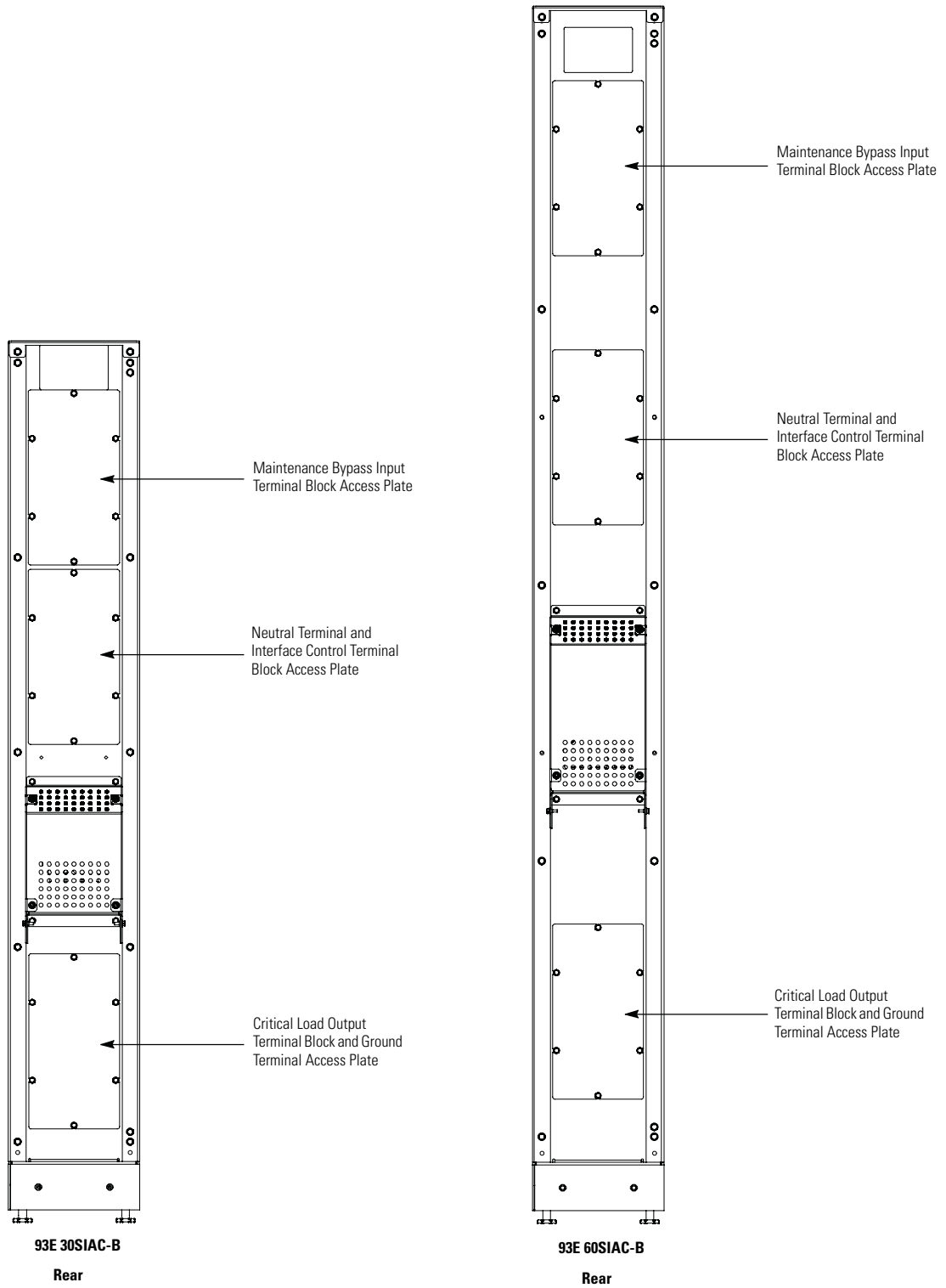
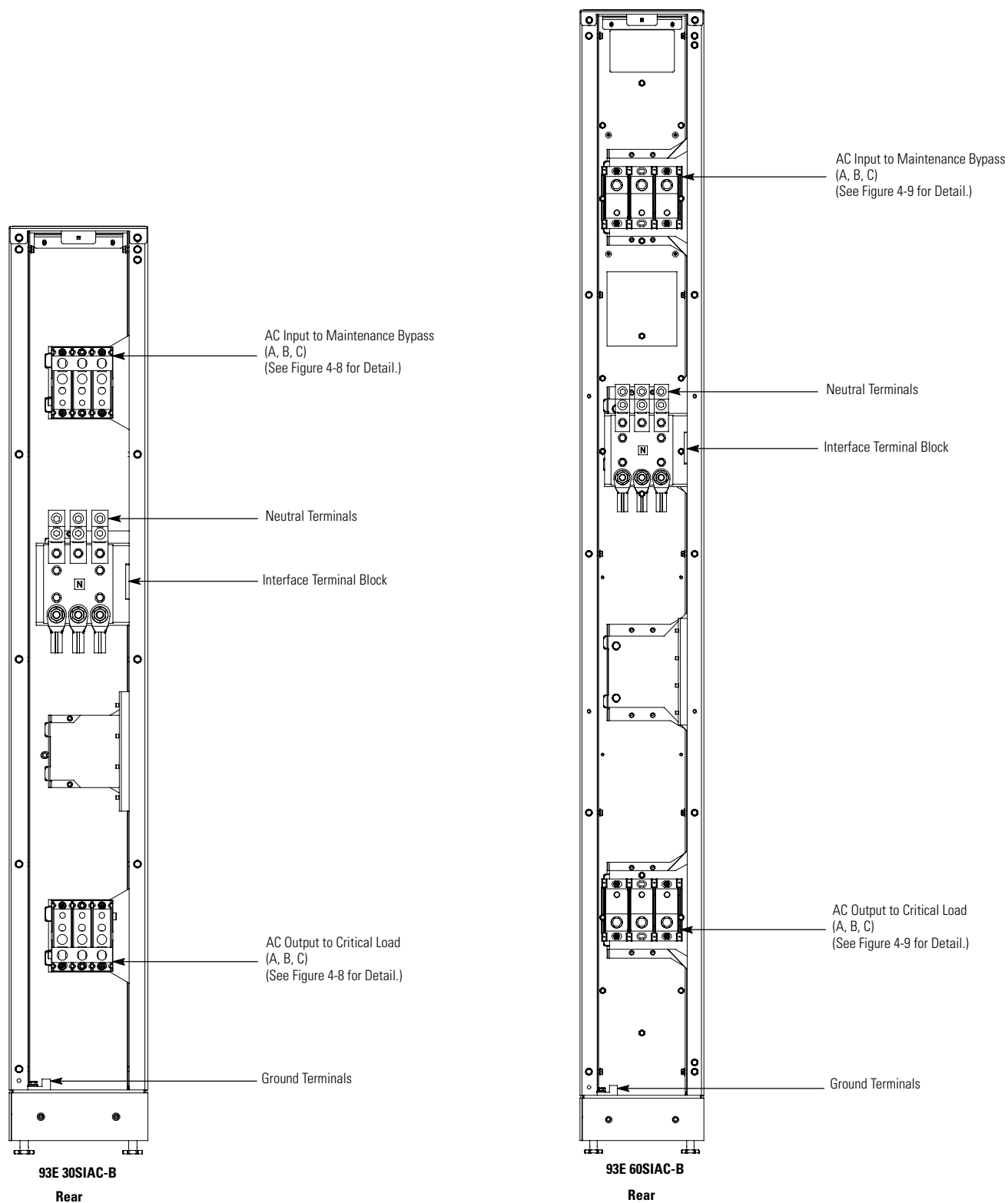
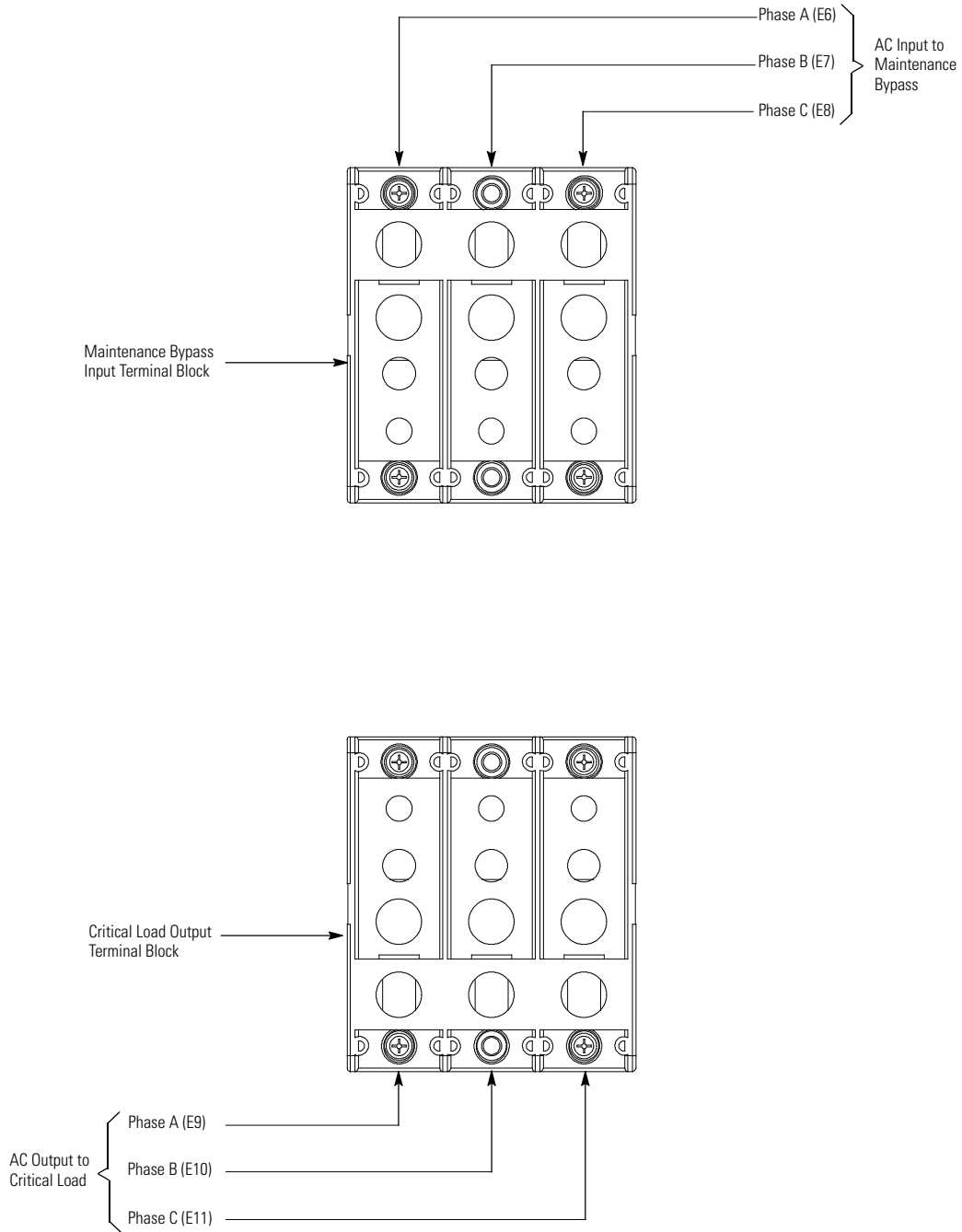


Figure 4-6. SIAC-B Terminal Access Plates

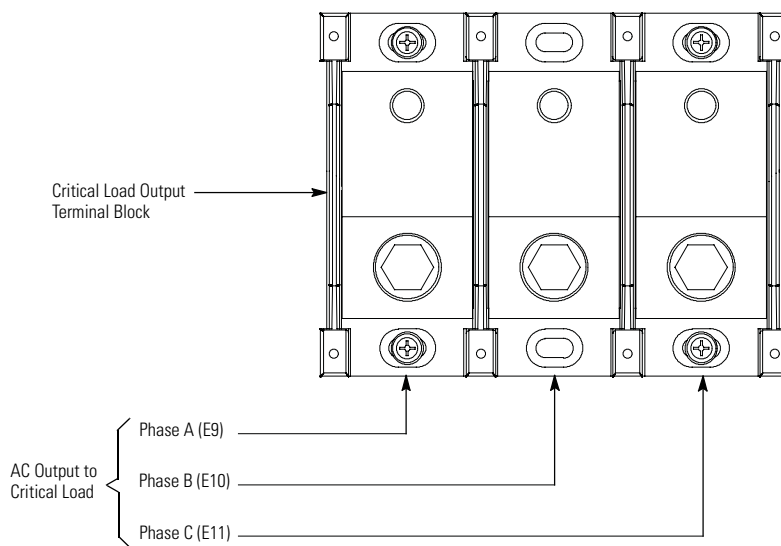
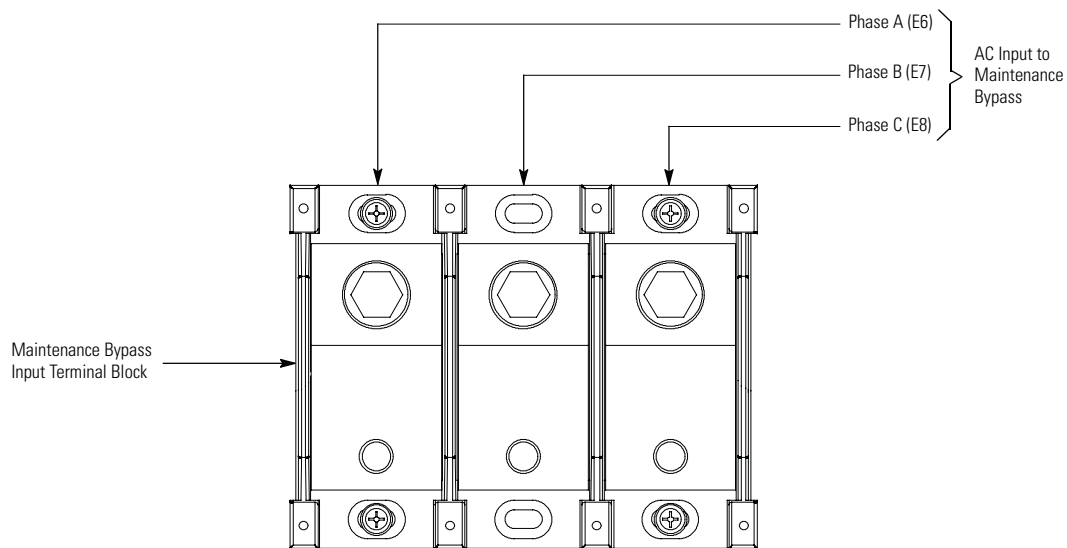


**Figure 4-7. SIAC-B Bypass Input, Neutral, Ground, and Output Power Terminal Locations**



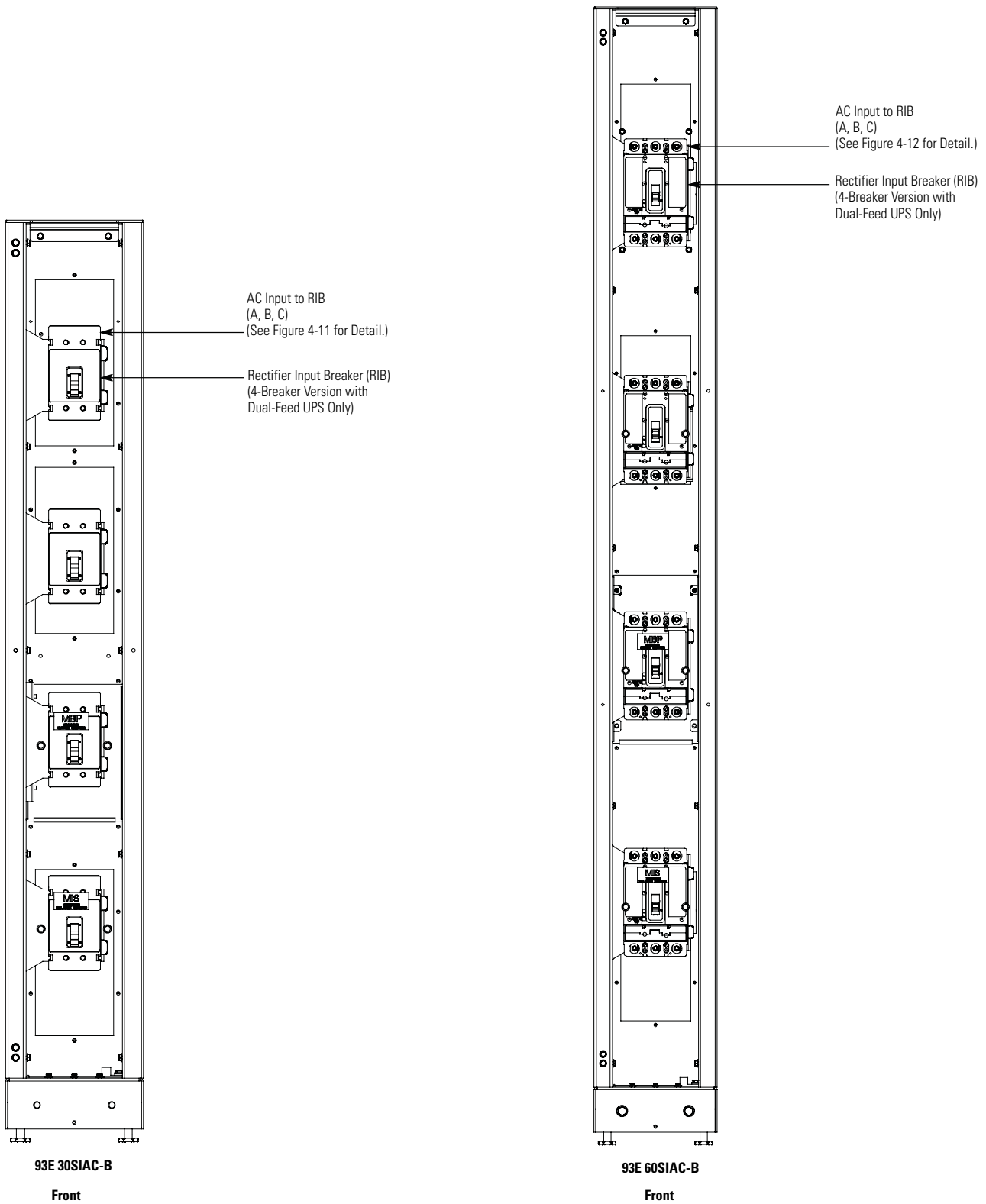
**Figure 4-8. 93E 30SIAC-B Bypass Input and Output Power Terminal Detail**



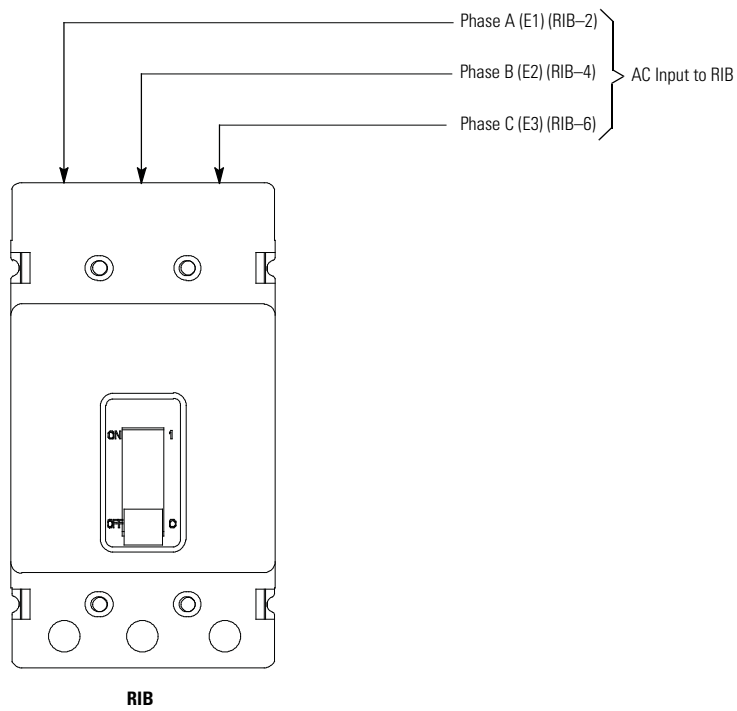


**Figure 4-9. 93E 60SIAC-B Bypass Input and Output Power Terminal Detail**

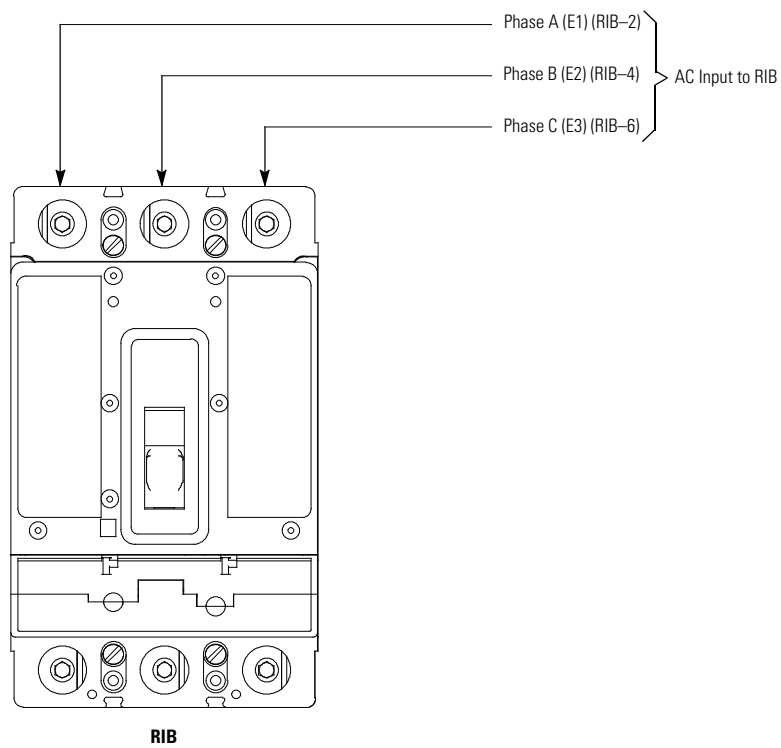
# Installation



**Figure 4-10. SIAC-B RIB Terminal Locations**



**Figure 4-11. 93E 30SIAC-B RIB Terminal Detail**



**Figure 4-12. 93E 60SIAC-B RIB Terminal Detail**

## 4.5 Installing SIAC-B Interface Connections

**NOTE 1** SIAC-B MBP auxiliary contact control interface wiring is prewired to the SIAC-B terminal block. Table 4-2, Figure 4-13, and Figure 4-14 are for reference only.



**NOTE 2** Interface wiring is installed by routing wiring through the UPS power terminal cover base wiring channel.

**NOTE 3** Keep interface wiring separate from power wiring or use shielded wire in the power terminal wiring channel.

To install wiring:

1. Verify the UPS system is turned off and all power sources are removed. Refer to the applicable Eaton 93E UPS Installation and Operation manual listed in paragraph 1.7, for UPS operating procedures.
2. Locate the black and white twisted pair cable at the back of the SIAC-B. Route the cable to the UPS power terminal cover base wiring channel. Refer to the applicable Eaton 93E UPS Installation and Operation manual listed in paragraph 1.7 for wiring channel location.
3. Connect the MBP auxiliary contact wiring from the SIAC-B to the UPS building alarm 1 terminals. See Table 4-1 for terminal information. Refer to the applicable Eaton 93E UPS Installation and Operation manual listed in paragraph 1.7, for UPS cabinet terminal locations, termination requirements, and installation instructions.
4. Proceed to paragraph 4.6.

**Table 4-1. SIAC-B MBP Interface Terminals**

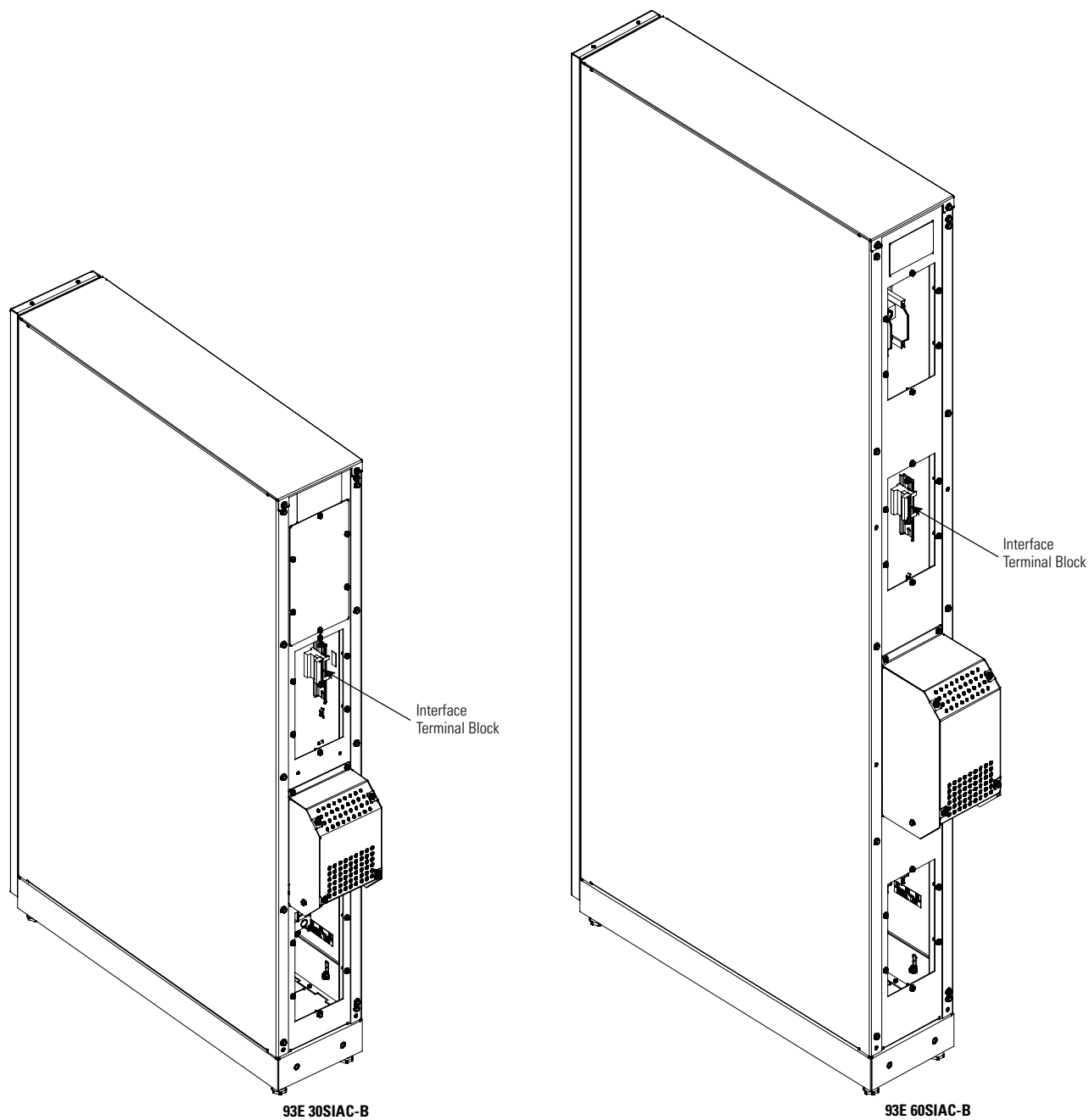
SIAC-B Terminal	Name	Wire Color	UPS Terminal	Description
TB-01	MBP Aux #1 NO	White	Building Alarm 1 (Pin1)	Output: Normally Open (NO) contact used to indicate whether the MBP is closed and the UPS system is on maintenance bypass. Contacts are closed when the MBP is closed.
TB-02	MBP Aux #1 Common	Black	Building Alarm 1 Return (Pin 2)	
TB-03	MBP Aux #1 NC			Not Used
TB-04	MBP Aux #2 NO			Not Used
TB-05	MBP Aux #2 Common			Not Used
TB-06	MBP Aux #2 NC			Not Used
TB-07	Empty			Not Used
TB-08	Empty			Not Used
TB-09	Empty			Not Used
TB-10	Empty			Not Used

**NOTE** UPS building alarm signals are customer programmable. Customer interface wiring for the SIAC-B MBP assumes that UPS Building Alarm 1 is programmed to monitor Normally Open (NO) contacts.

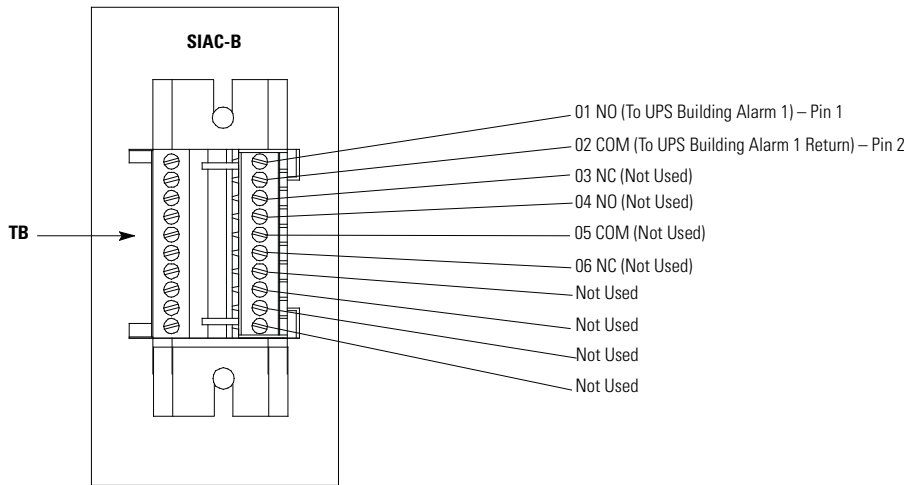
**NOTE** “Common” indicates connection to common side of isolated relay contact.

**Table 4-2. SIAC-B Interface Wiring Terminal Block Terminations**

Terminal Function	Size of Pressure Termination	Tightening Torque Nm (lb in)	Type Screw	Comments
Auxiliary Contacts	#22–#14	0.8 (7.0)	Slotted	Use twisted-pair wires for each input and return or common. Strip wire insulation back 10 millimeters to wire terminal blocks.



**Figure 4-13. SIAC-B Interface Terminal Location**



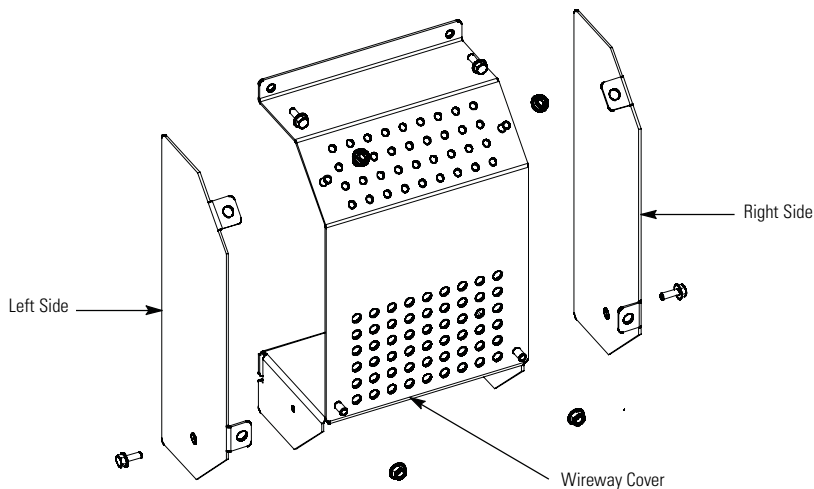
**NOTE** UPS building alarm signals are customer programmable. Customer interface wiring for the SIAC-B MBP assumes that UPS Building Alarm 1 is programmed to monitor Normally Open (NO) contacts.

**Figure 4-14. SIAC-B Interface Terminal Detail**

#### 4.6 Wireway Cover and Splice Installation

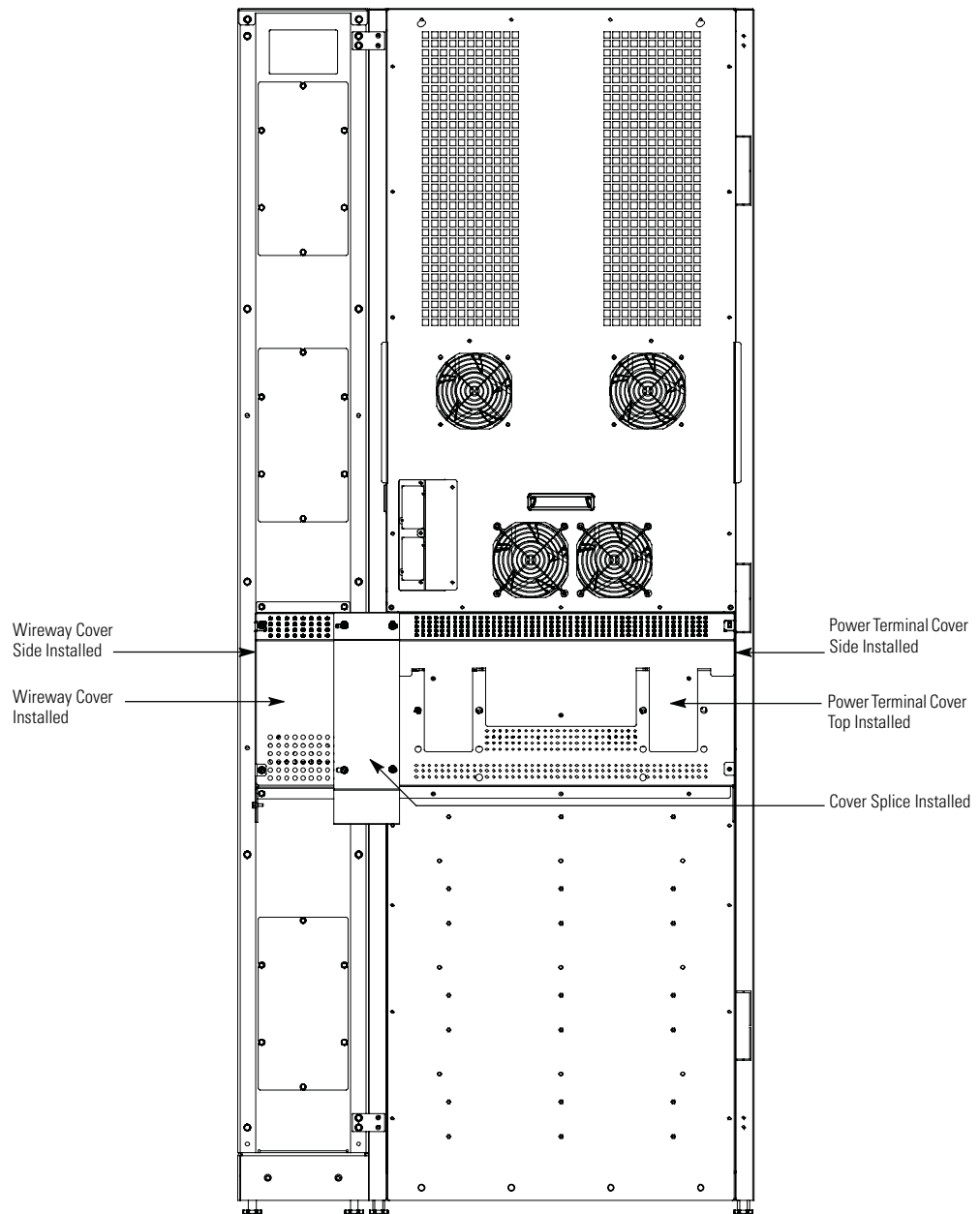
To install the Wireway Cover:

1. Locate the wireway cover (see Figure 4-15) from the parts kit.
2. Using the hardware provided, install the wireway cover to the back panel of the SIAC-B using the existing cabinet screw holes (see Figure 4-16).
3. Install the wireway cover left or right sides as appropriate using the hardware provided (see Figure 4-15 and Figure 4-16).
4. Install the splice cover using the provided hardware (see Figure 4-16).
5. After the IAC-B is installed and wired, return to the applicable Eaton 93E UPS Installation and Operation manual listed in paragraph 1.7 to complete the UPS installation.



**NOTE** Do not install the Power Terminal Cover Left and/or Right Side covers if wiring adjacent cabinets using the power terminal base wiring channel.

**Figure 4-15. Wireway Cover**



**NOTE 1** The 93E 60SIAC-B is shown. The 93E 30SIAC-B wireway cover and splice are attached using the same method.

**NOTE 2** A right-mounted SIAC-B is shown. A left-mounted SIAC-B is the mirror image.

**NOTE 3** Do not install the Power Terminal Cover Left and/or Right Side covers if wiring adjacent cabinets using the power terminal base wiring channel.

**Figure 4-16. Wireway Cover and Splice Installation**

## 4.7 Initial Startup

Startup and operational checks must be performed by an authorized Eaton Customer Service Engineer, or the warranty terms specified on page W-1 become void. This service is offered as part of the sales contract for the UPS. Contact an Eaton service representative in advance (usually a two-week notice is required) to reserve a preferred startup date.

## 4.8 Completing the Installation Checklist

The final step in installing the SIAC-B is completing the following Installation Checklist. This checklist ensures that you have completely installed all hardware, cables, and other equipment. Complete all items listed on the checklist to ensure a smooth installation. Make a copy of the Installation Checklist before filling it out, and retain the original.

After the installation is complete, an Eaton Customer Service Engineer must verify the operation of the UPS system and commission it to support the critical load. The service representative cannot perform any installation tasks other than verifying software and operating setup parameters. Service personnel may request a copy of the completed Installation Checklist to verify all applicable equipment installations have been completed.



### NOTE

The Installation Checklist MUST be completed prior to starting the UPS system for the first time.

---

## Installation Checklist

- All packing materials and restraints have been removed from each cabinet.
- The SIAC-B is installed in a suitable location for computer or electronic equipment.
- The SIAC-B is attached to the adjacent 93E UPS cabinet with the cabinet brackets.
- All conduits and cables are properly routed between the SIAC-B and the UPS.
- All power cables are properly sized and terminated.
- A ground conductor is properly installed.
- Interface wiring between the SIAC-B and UPS cabinets is properly installed.
- All terminal cover plates are installed.
- Air conditioning equipment is installed and operating correctly.
- The area around the UPS system is clean and dust-free.
- Adequate workspace exists around the SIAC-B and other cabinets.
- Adequate lighting is provided around all SIAC-B and UPS equipment.
- A 120 Vac service outlet is located within 7.5 meters (25 feet) of the SIAC-B and UPS equipment.
- Startup and operational checks are performed by an authorized Eaton Customer Service Engineer.





This page intentionally left blank.

# **Section 2**

# **Operation**

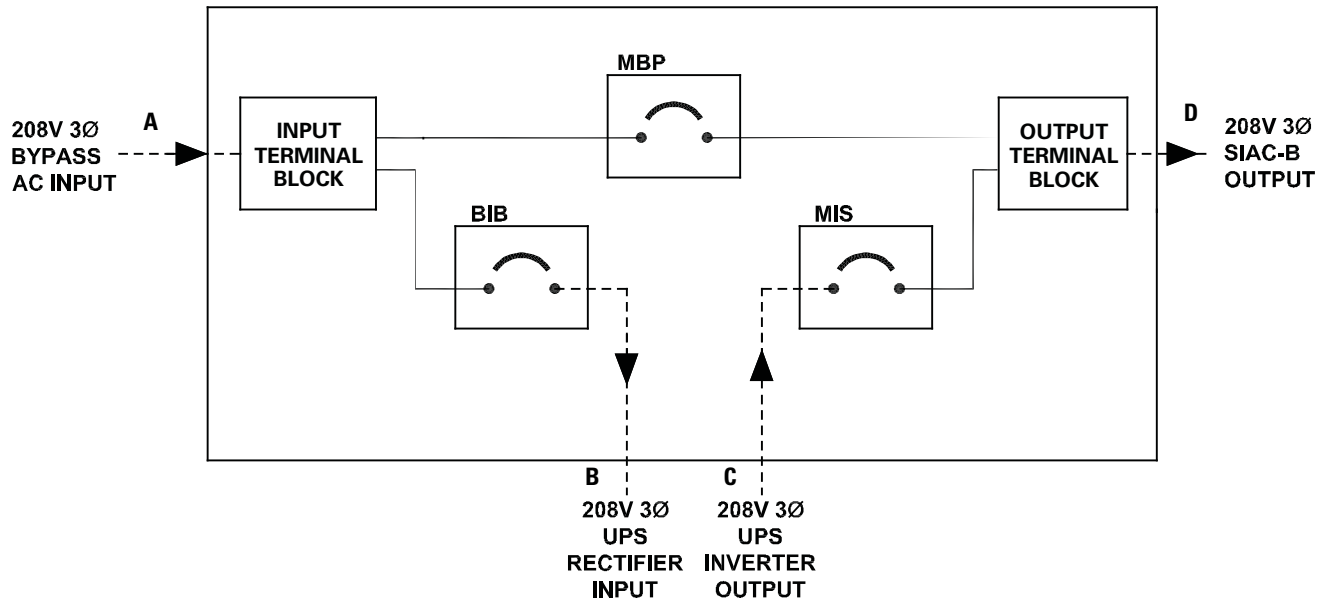


## Chapter 5 Onelines and Schematics

### 5.1 Onelines

Figure 5-1 and Figure 5-2 show the simplified internal structure of the Sidecar Integrated Accessory Cabinet-Bypass (SIAC-B).

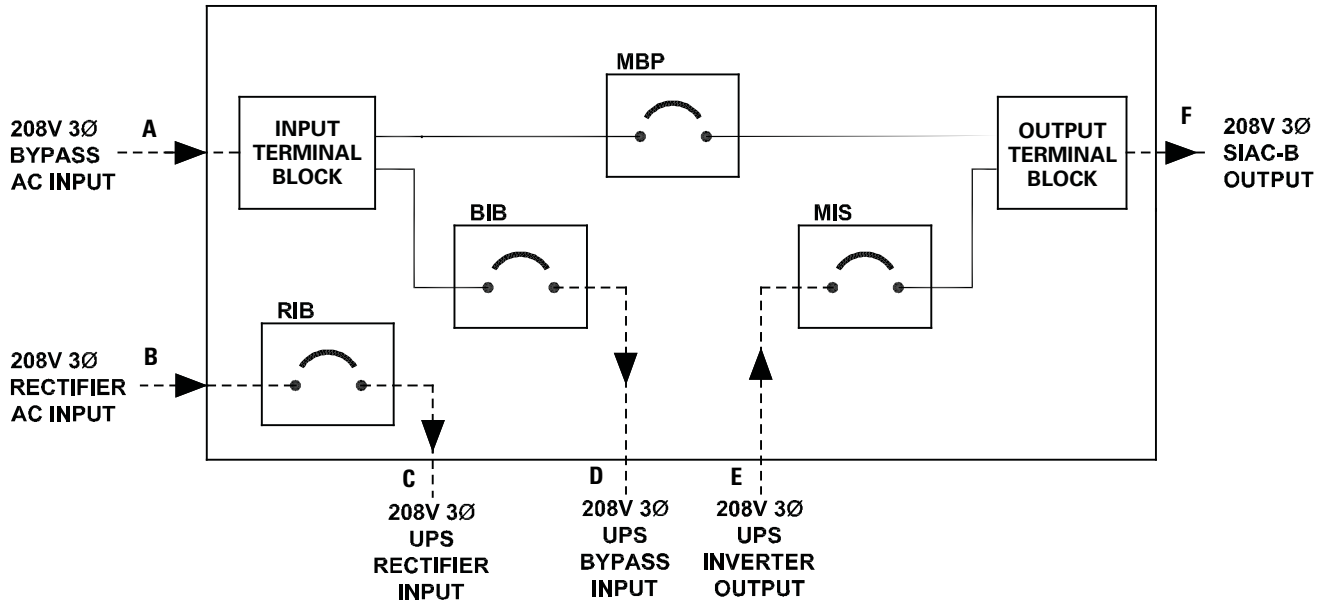
#### SIAC-B [3-BREAKER VERSION]



**NOTE** Callout letters **A**, **B**, **C**, and **D** map to Table 3-2.

**Figure 5-1. Three-Breaker Sidecar Integrated Accessory Cabinet-Bypass (SIAC-B) Internal Oneline**

### SIAC-B [4-BREAKER VERSION]

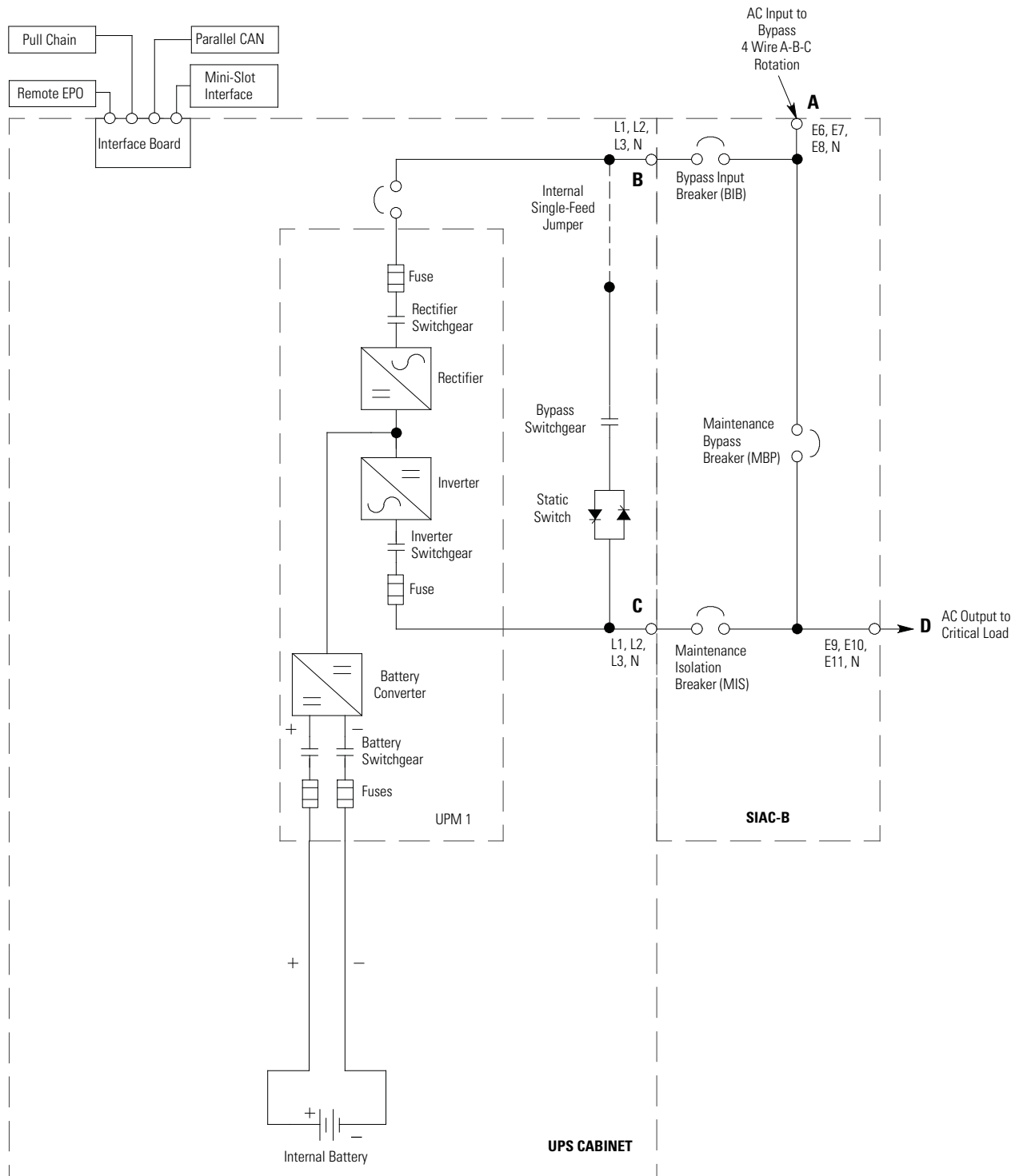


**NOTE** Callout letters **A, B, C, D, E, and F** map to Table 3-3.

**Figure 5-2. Four-Breaker Sidecar Integrated Accessory Cabinet-Bypass (SIAC-B) Internal Oneline**

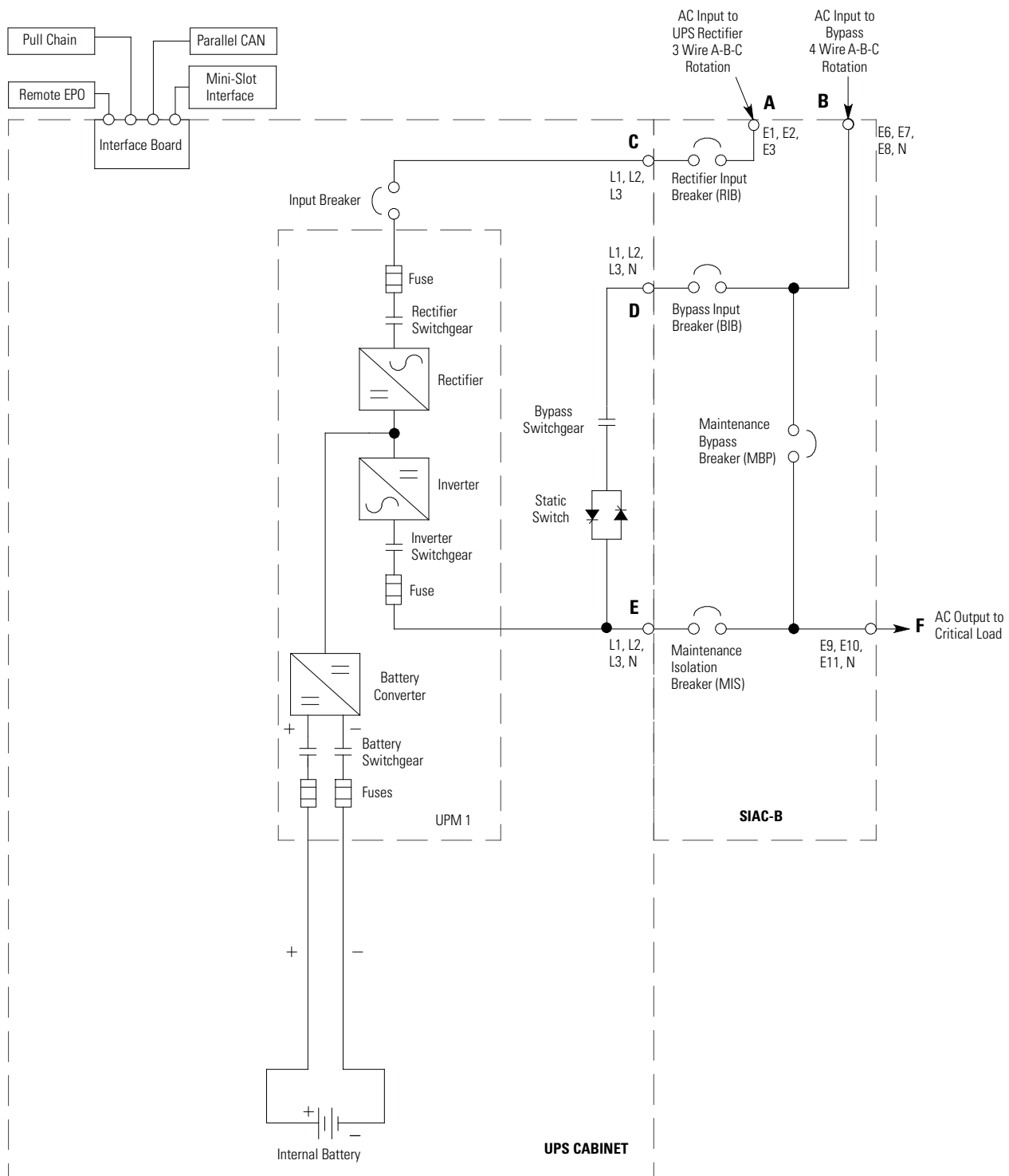
## 5.2 System Onelines

Figure 5-3 through Figure 5-14 show the simplified internal structure of the UPS, battery supply, and SIAC-B.



**NOTE** Callout letters **A**, **B**, **C**, and **D** map to Table 3-2.

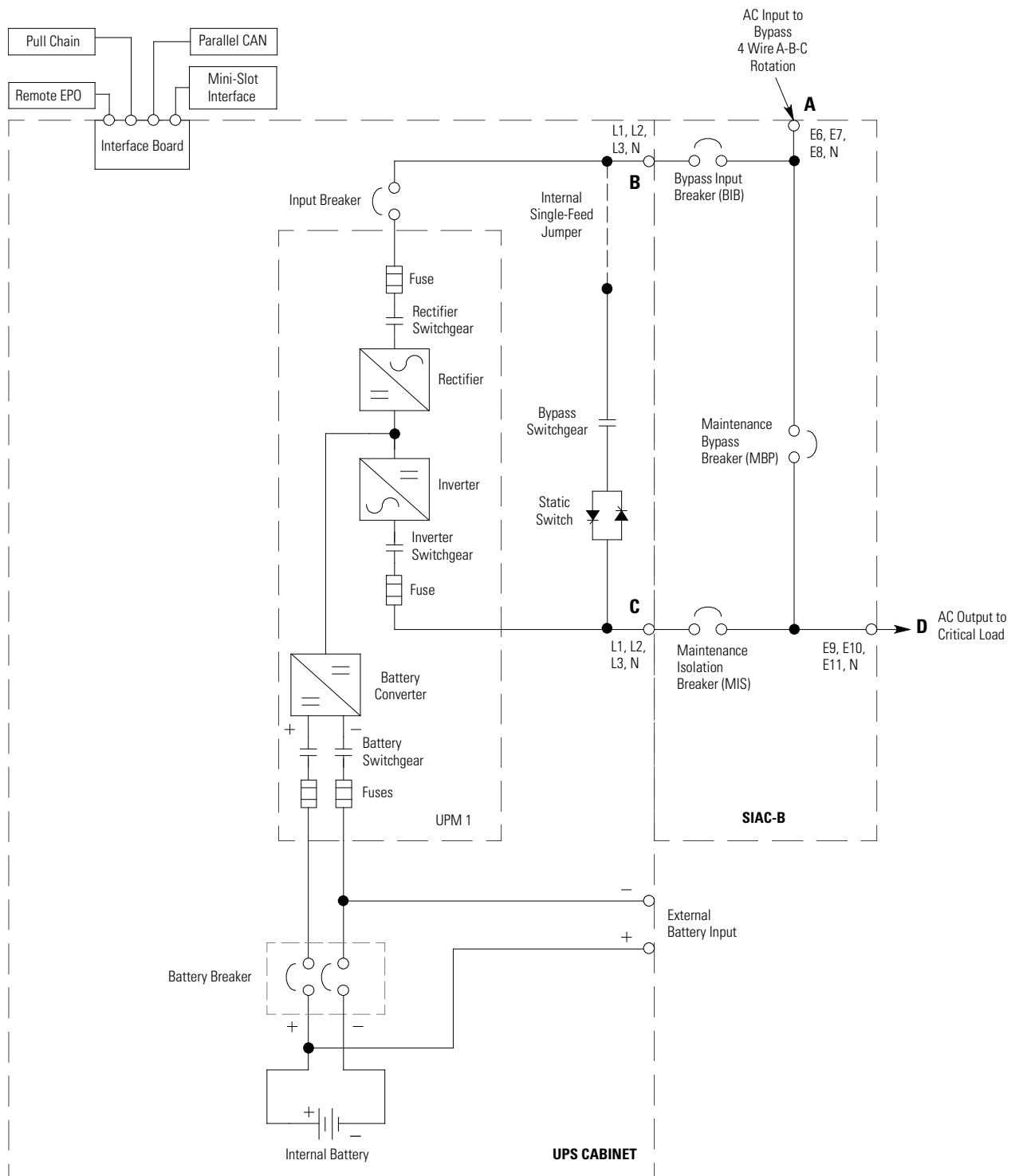
**Figure 5-3. 30 kVA UPS System Online – Internal Battery with Three-Breaker SIAC-B**



**NOTE** Callout letters **A, B, C, D, E, and F** map to Table 3-3.

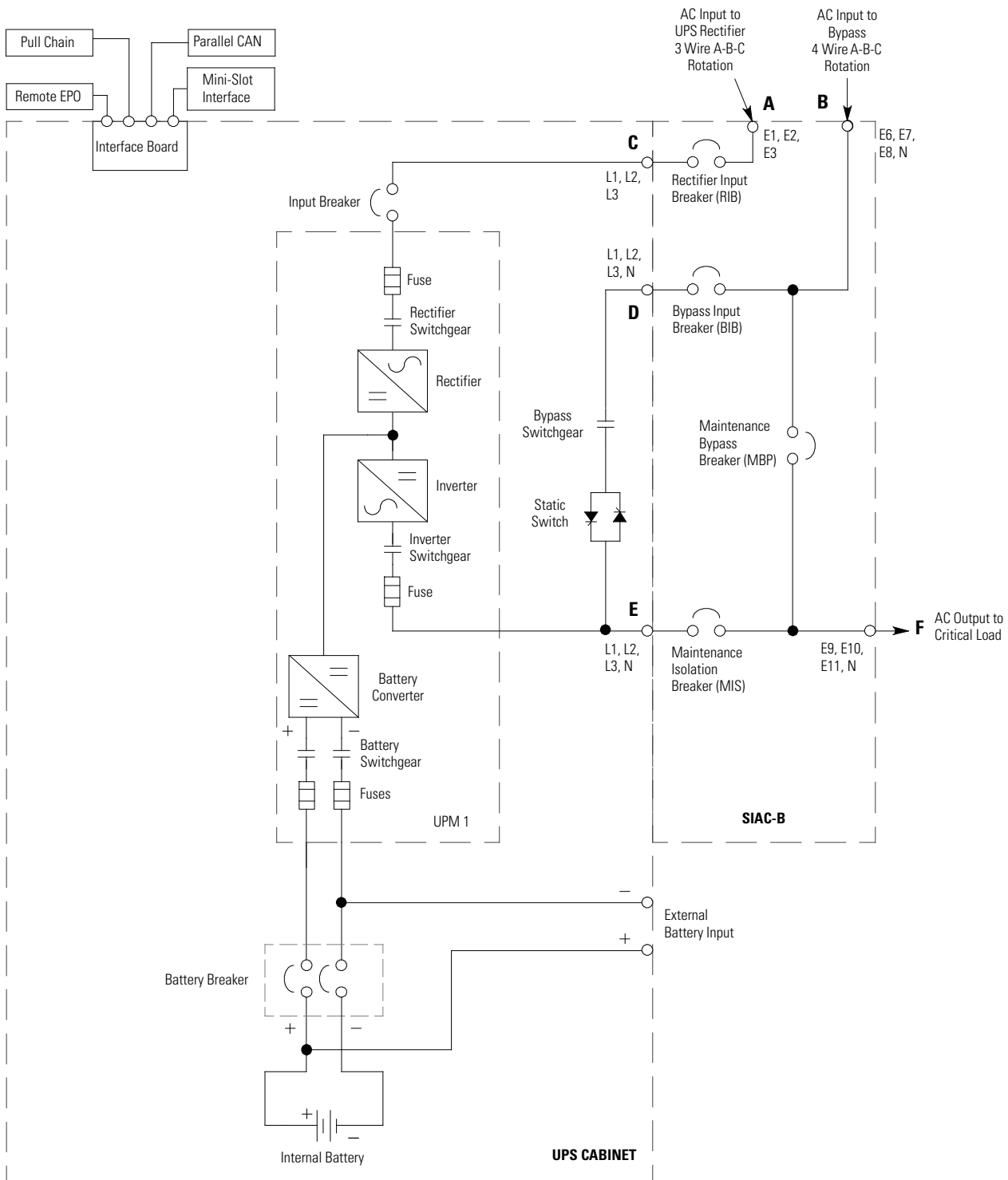
**Figure 5-4. 30 kVA UPS System Online – Internal Battery with Four-Breaker SIAC-B**





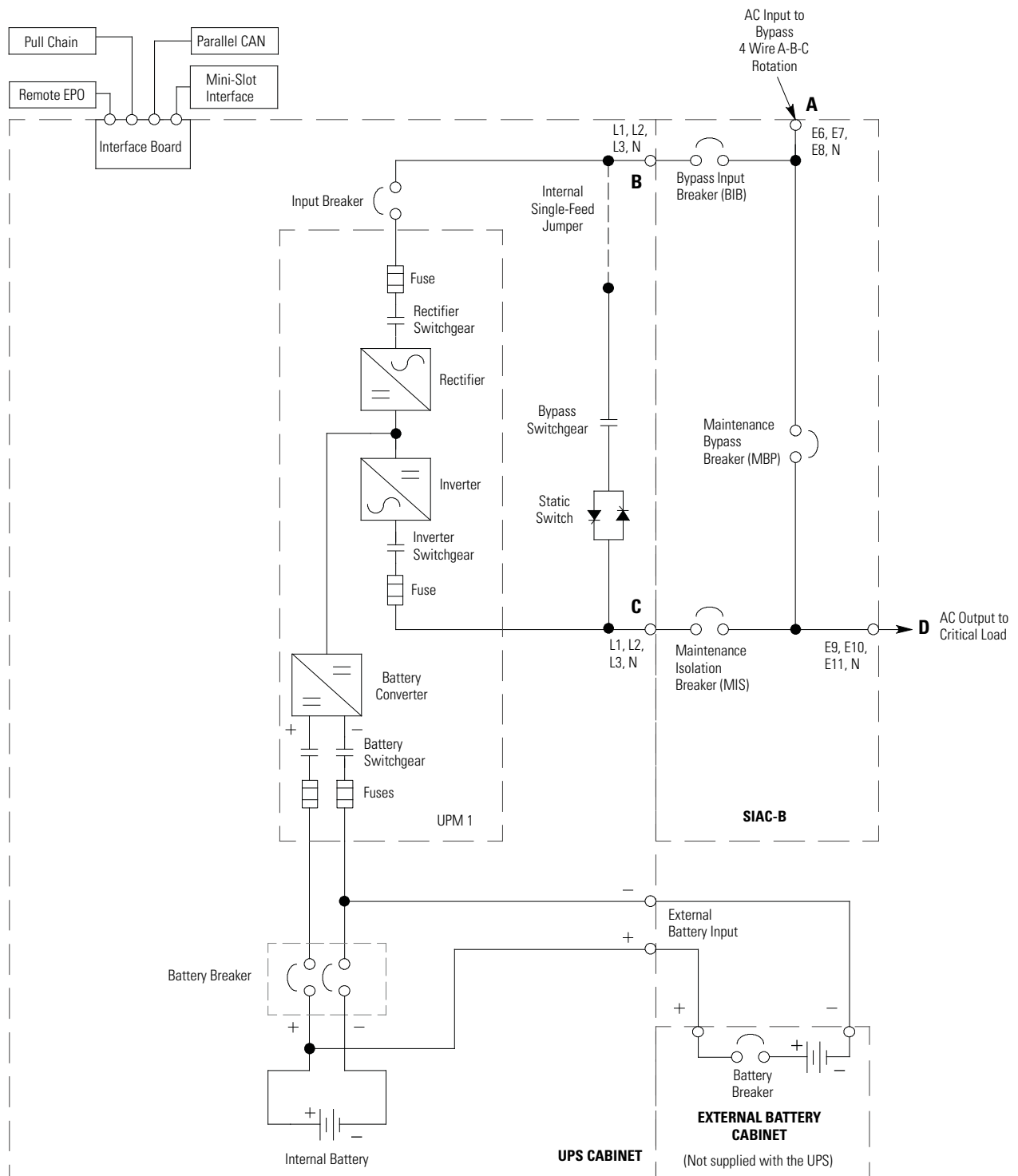
**NOTE** Callout letters **A**, **B**, **C**, and **D** map to Table 3-2.

**Figure 5-5. 30 kVA UPS System Online – Internal Battery and External Battery Capable with Three-Breaker SIAC-B**



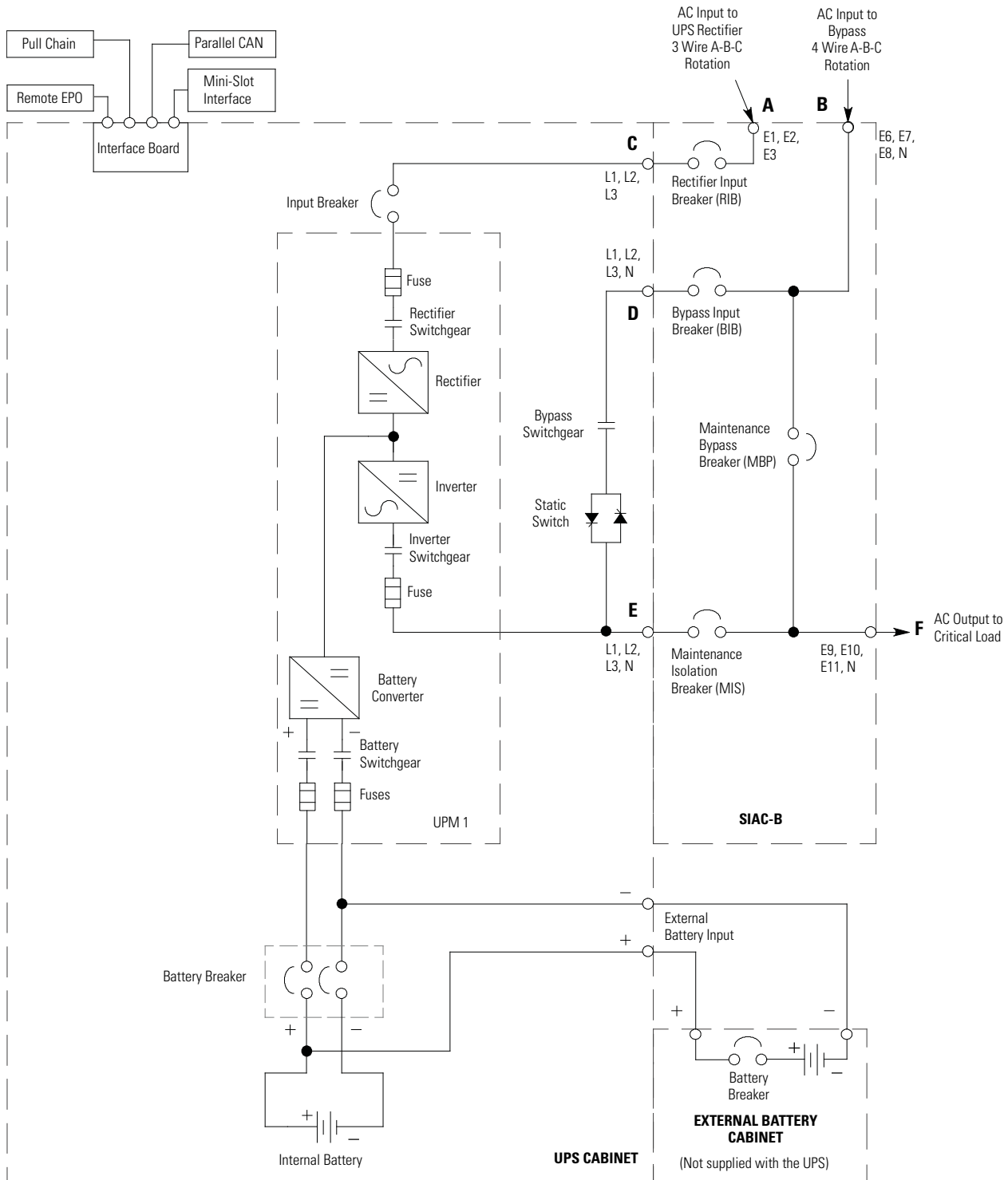
**NOTE** Callout letters **A, B, C, D, E, and F** map to Table 3-3.

**Figure 5-6. 30 kVA UPS System Online – Internal Battery and External Battery Capable with Four-Breaker SIAC-B**



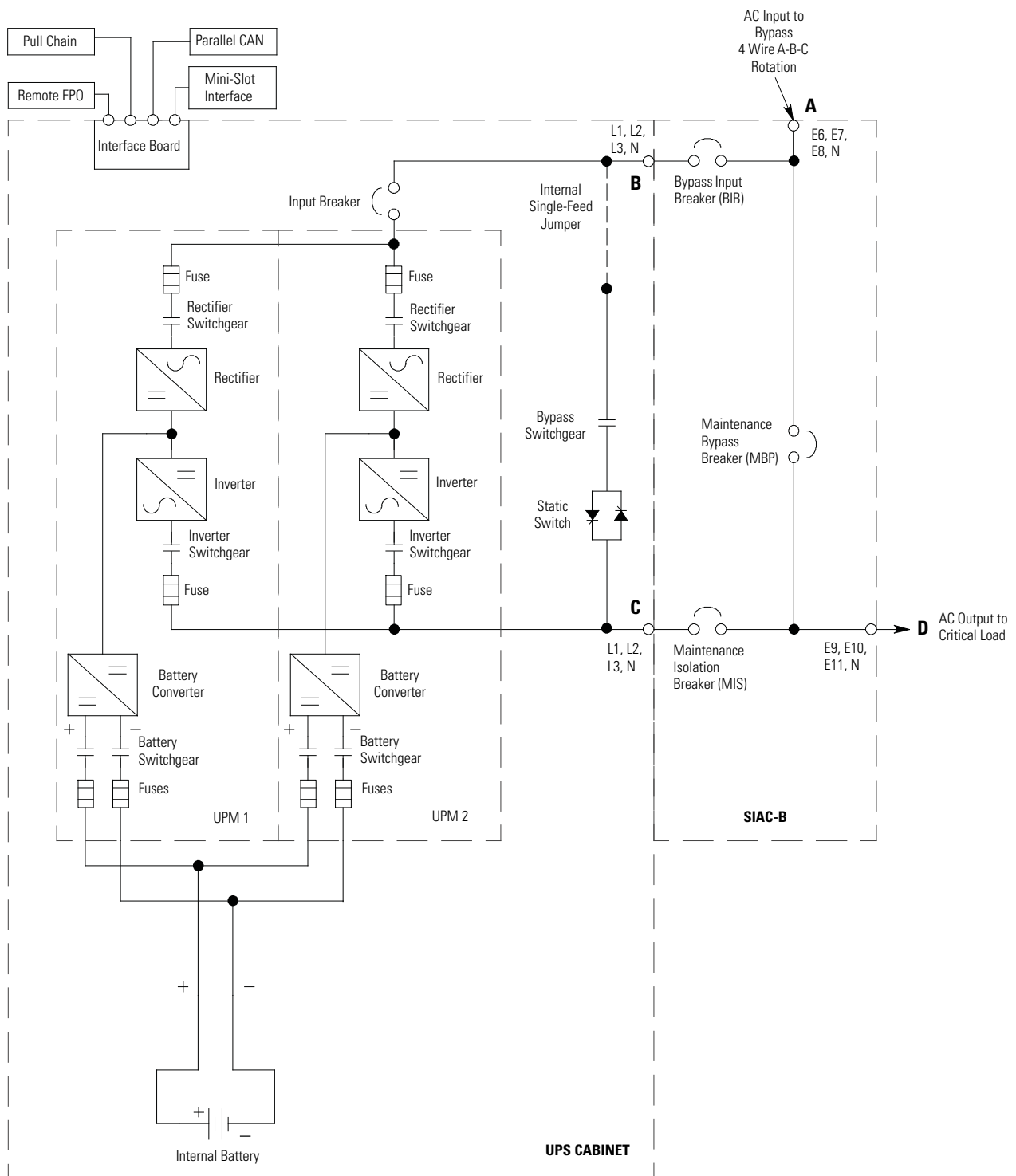
**NOTE** Callout letters **A**, **B**, **C**, and **D** map to Table 3-2.

**Figure 5-7. 30 kVA UPS System Online – Internal and External Batteries with Three-Breaker SIAC-B**



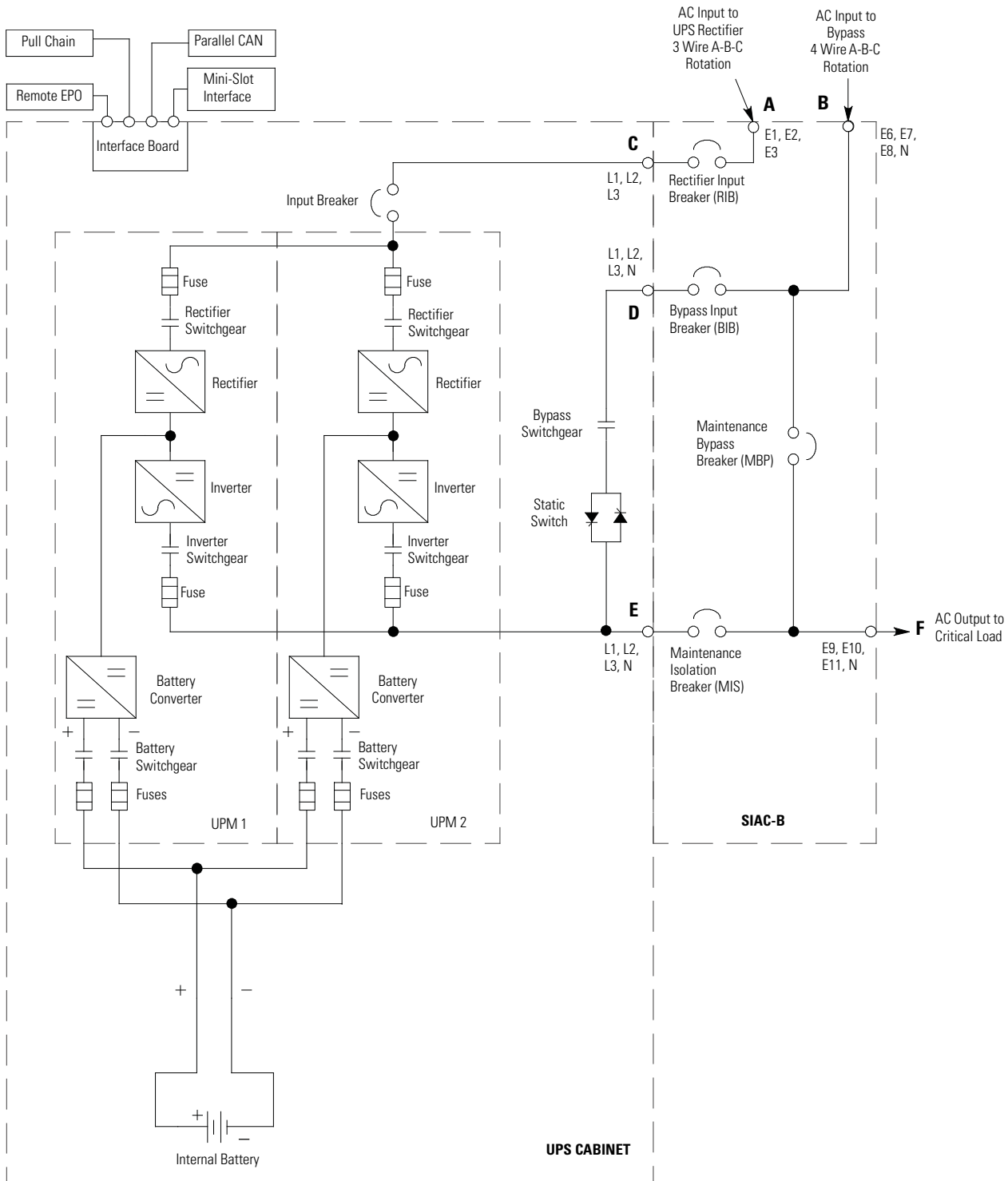
**NOTE** Callout letters **A, B, C, D, E, and F** map to Table 3-3.

**Figure 5-8. 30 kVA UPS System Online – Internal and External Batteries with Four-Breaker SIAC-B**



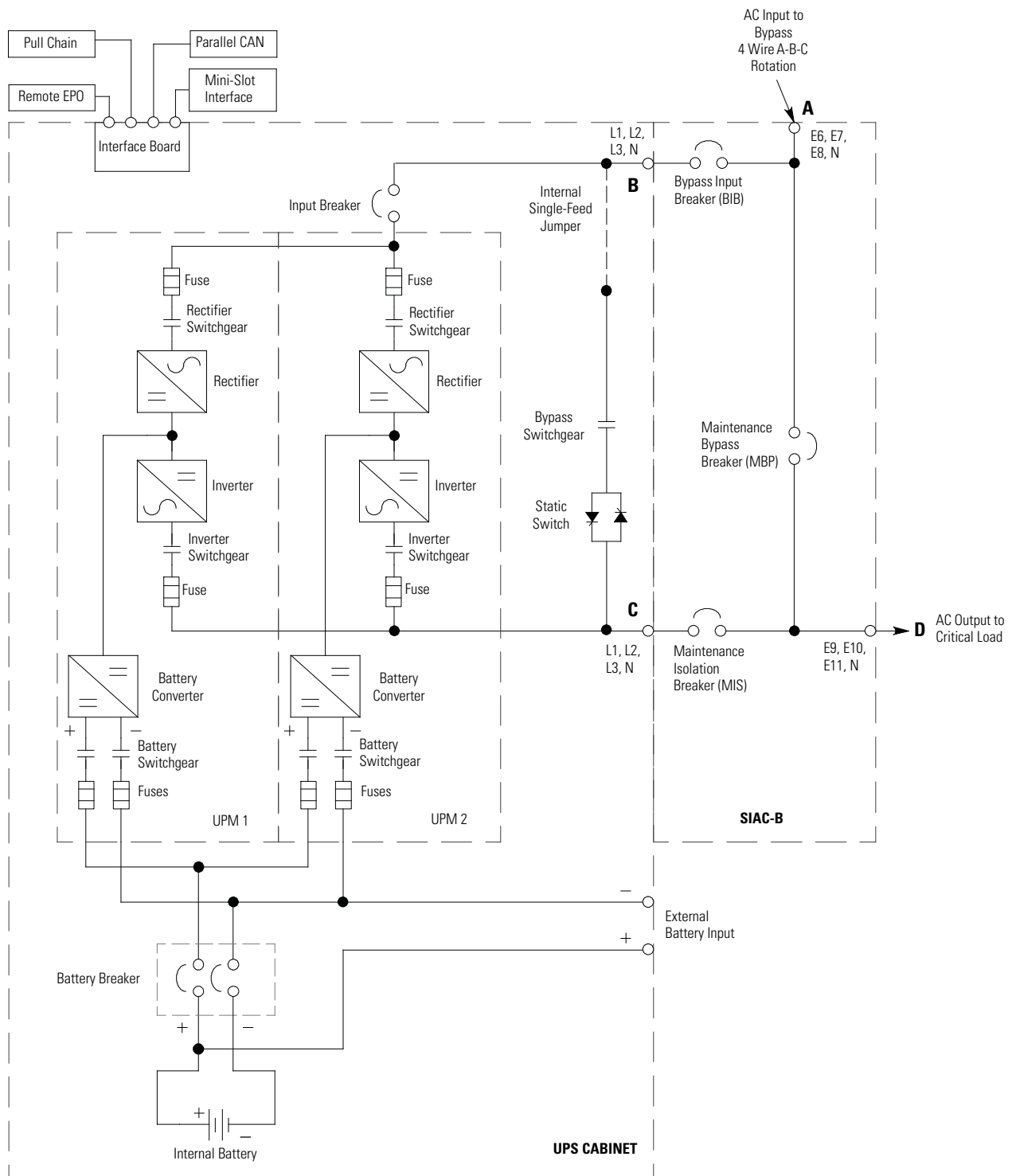
**NOTE** Callout letters **A**, **B**, **C**, and **D** map to Table 3-2.

**Figure 5-9. 60 kVA UPS System Online – Internal Battery with Three-Breaker SIAC-B**



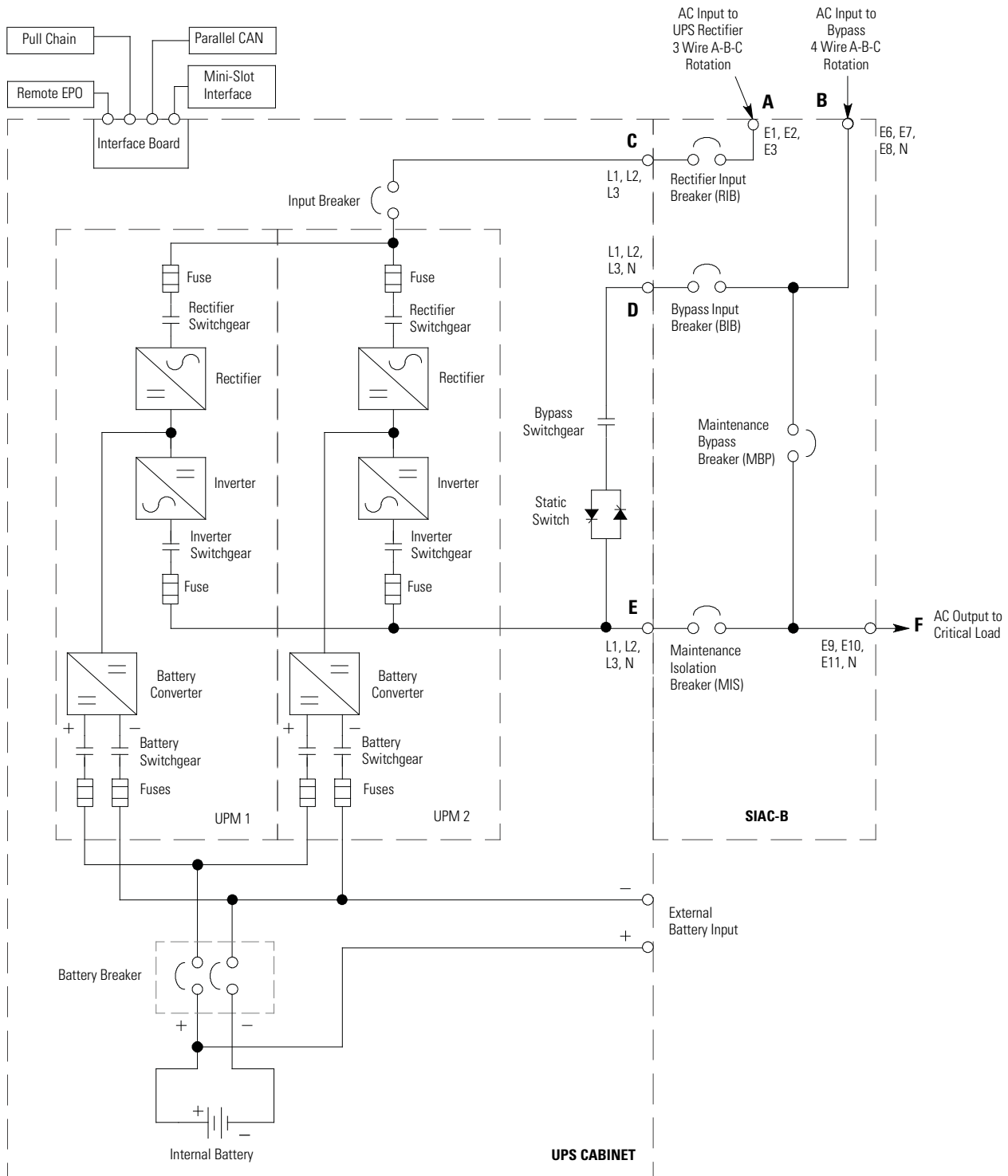
**NOTE** Callout letters **A, B, C, D, E, and F** map to Table 3-3.

**Figure 5-10. 60 kVA UPS System Online – Internal Battery with Four-Breaker SIAC-B**



**NOTE** Callout letters **A**, **B**, **C**, and **D** map to Table 3-2.

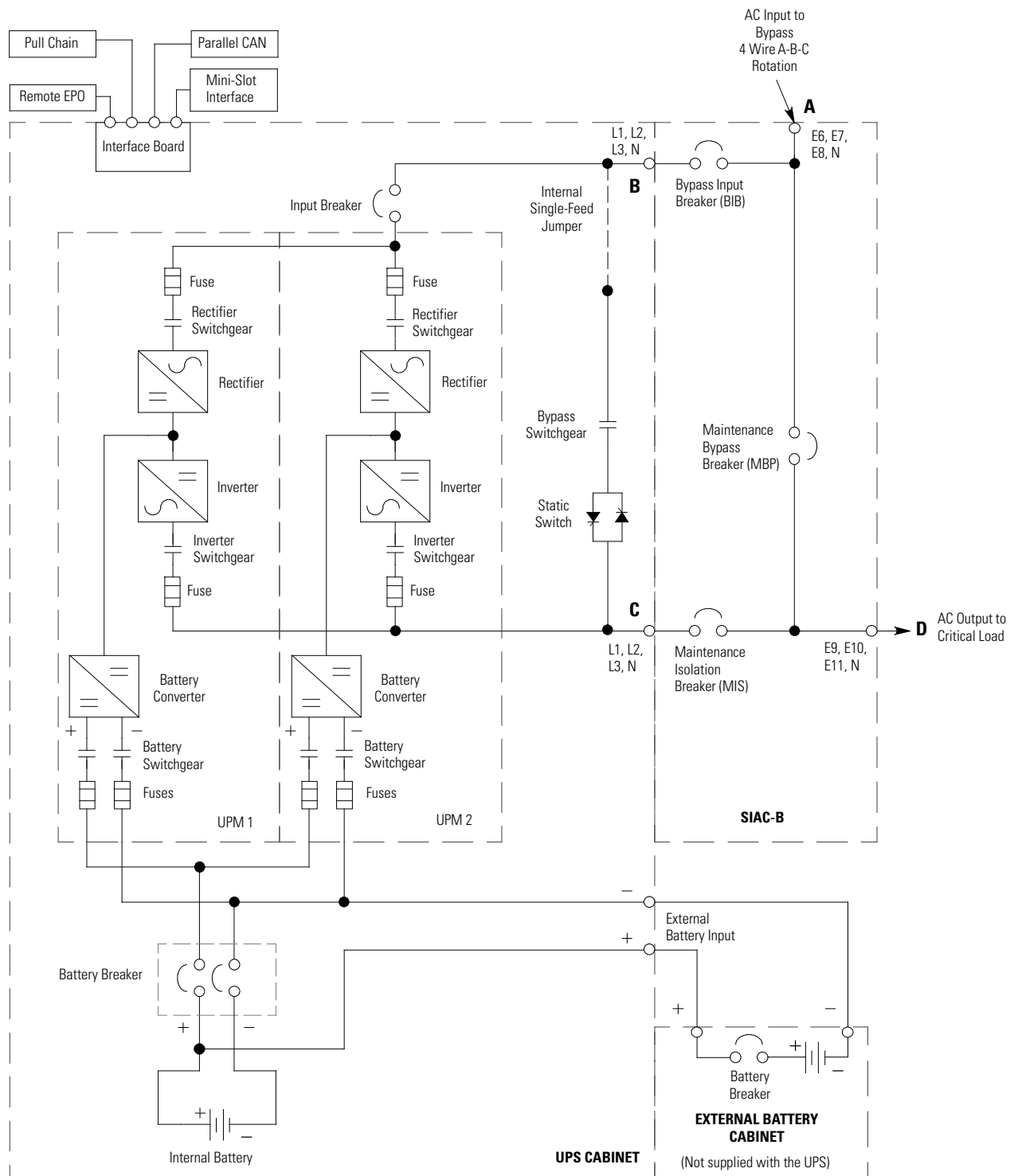
**Figure 5-11. 60 kVA UPS System Online – Internal Battery and External Battery Capable with Three-Breaker SIAC-B**



**NOTE** Callout letters **A, B, C, D, E, and F** map to Table 3-3.

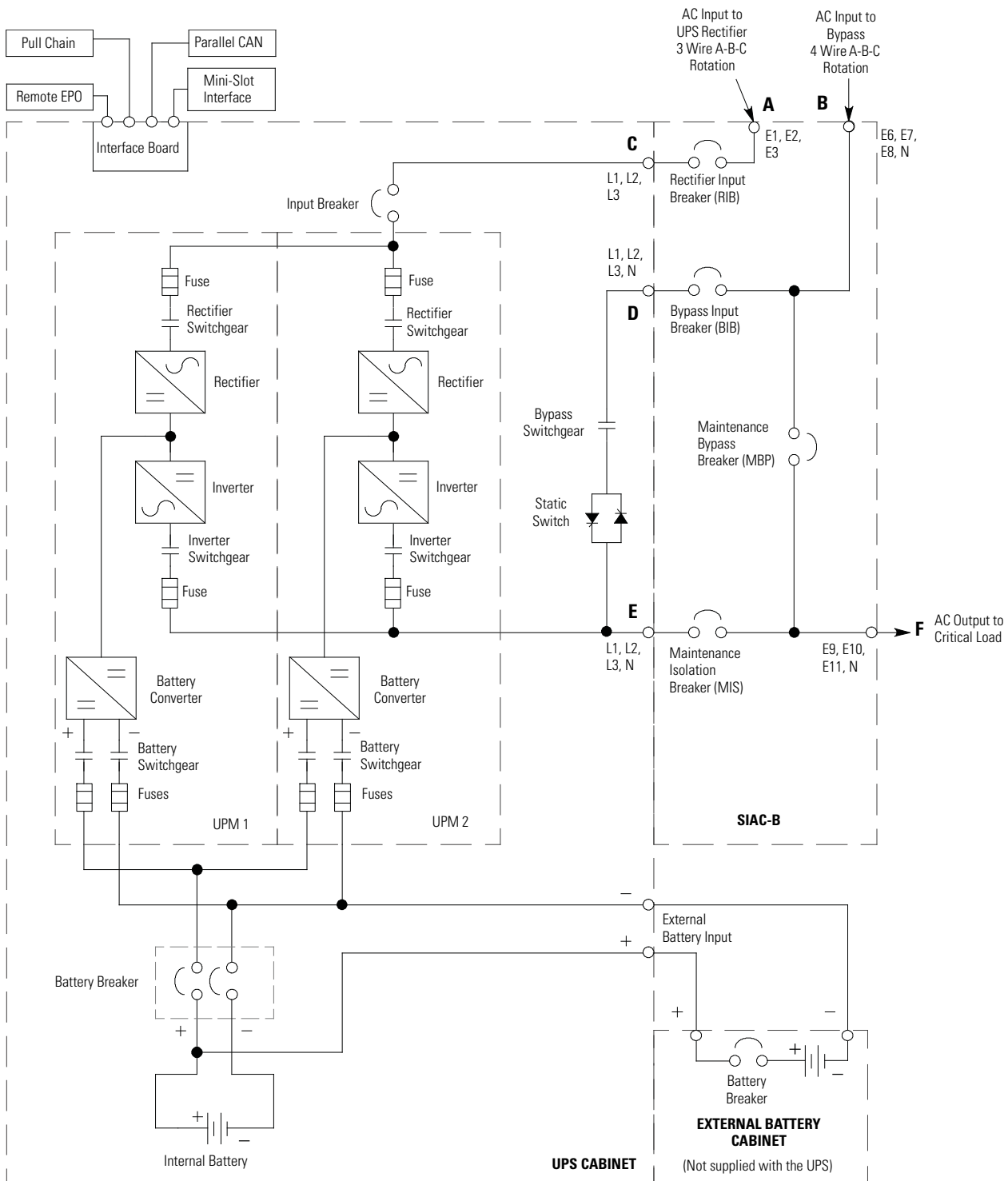
**Figure 5-12. 60 kVA UPS System Online – Internal Battery and External Battery Capable with Four-Breaker SIAC-B**





NOTE Callout letters **A**, **B**, **C**, and **D** map to Table 3-2.

Figure 5-13. 60 kVA UPS System Online – Internal and External Batteries with Three-Breaker SIAC-B

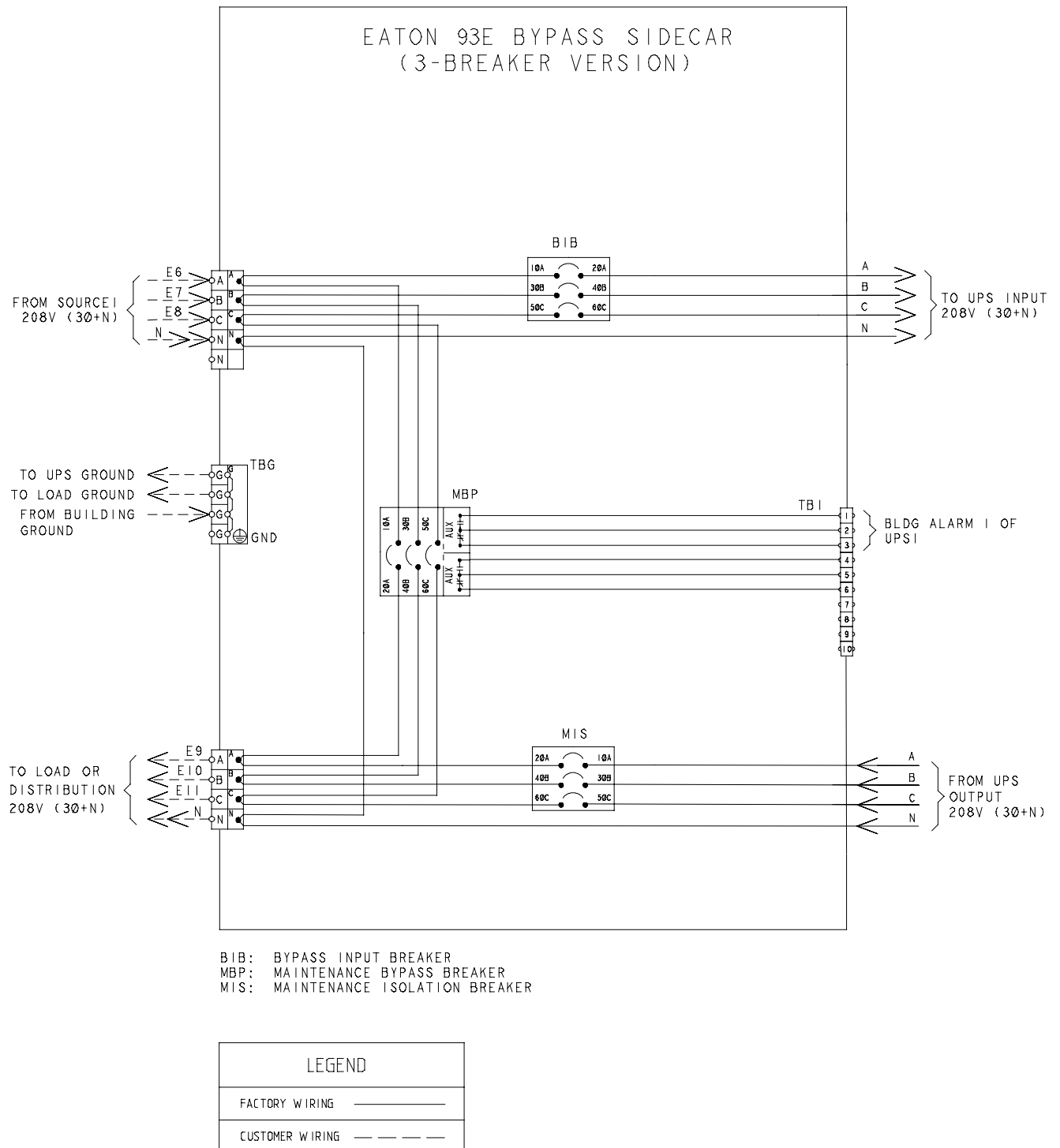


**NOTE** Callout letters **A, B, C, D, E, and F** map to Table 3-3.

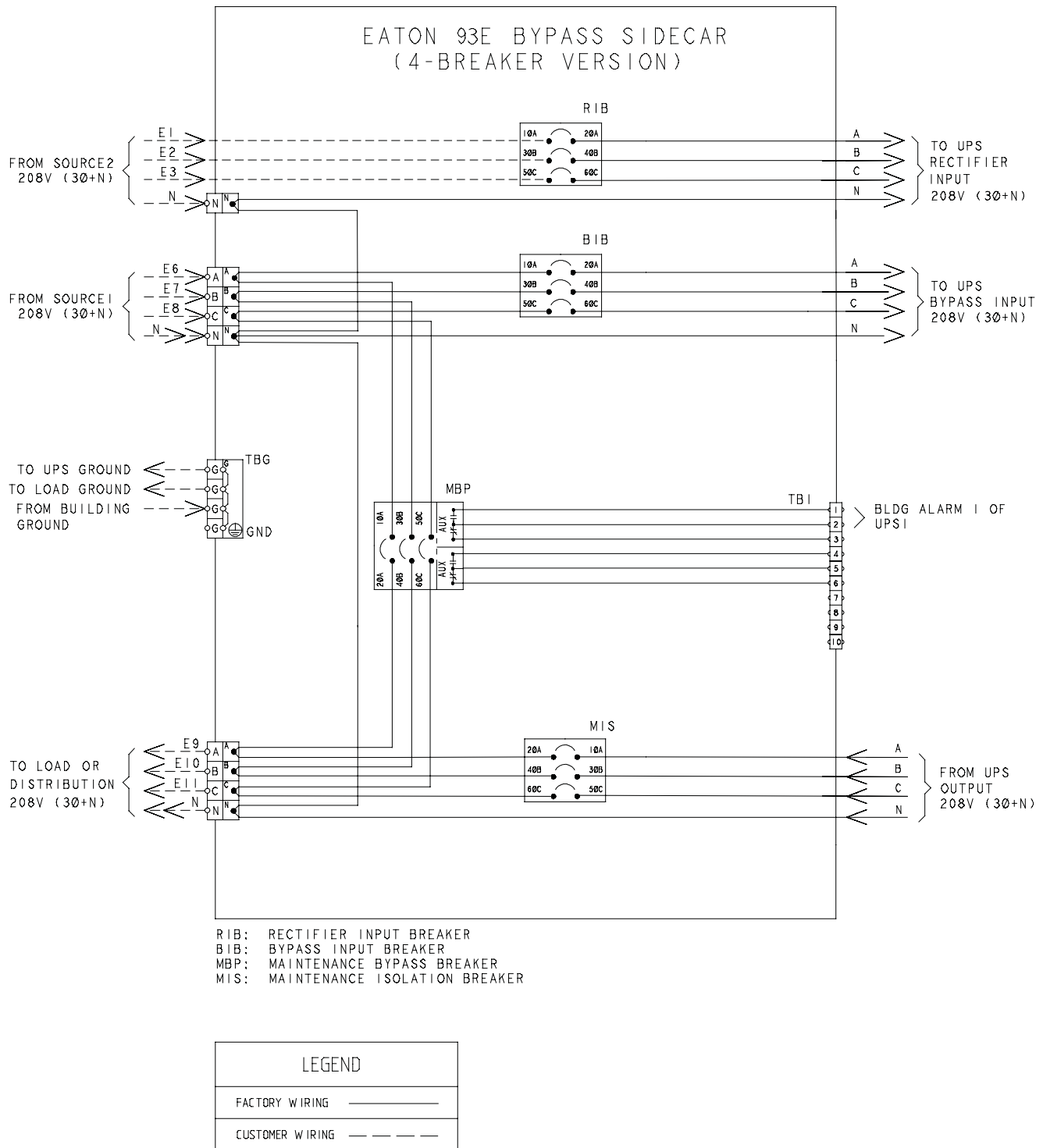
**Figure 5-14. 60 kVA UPS System Online – Internal and External Batteries with Four-Breaker SIAC-B**

### 5.3 Schematics

Figure 5-15 and Figure 5-16 show the SIAC-B schematics.



**Figure 5-15. Eaton 93E 30SIAC-B and 93E 60SIAC-B Three-Breaker Schematic**



**Figure 5-16. Eaton 93E 30SIAC-B and 93E 60SIAC-B Four-Breaker Schematic**

## Chapter 6 Sidecar Integrated Accessory Cabinet-Bypass Operating Instructions

This section describes how to operate the Sidecar Integrated Accessory Cabinet-Bypass (SIAC-B).

---

**NOTE 1** Before using the SIAC-B, ensure all installation tasks are complete and a preliminary startup has been performed by authorized service personnel. The preliminary startup verifies all electrical interconnections to ensure the installation was successful and the system operates properly.



**NOTE 2** Read this section of the manual and have thorough knowledge of UPS and SIAC-B operation before attempting to operate any of the controls.

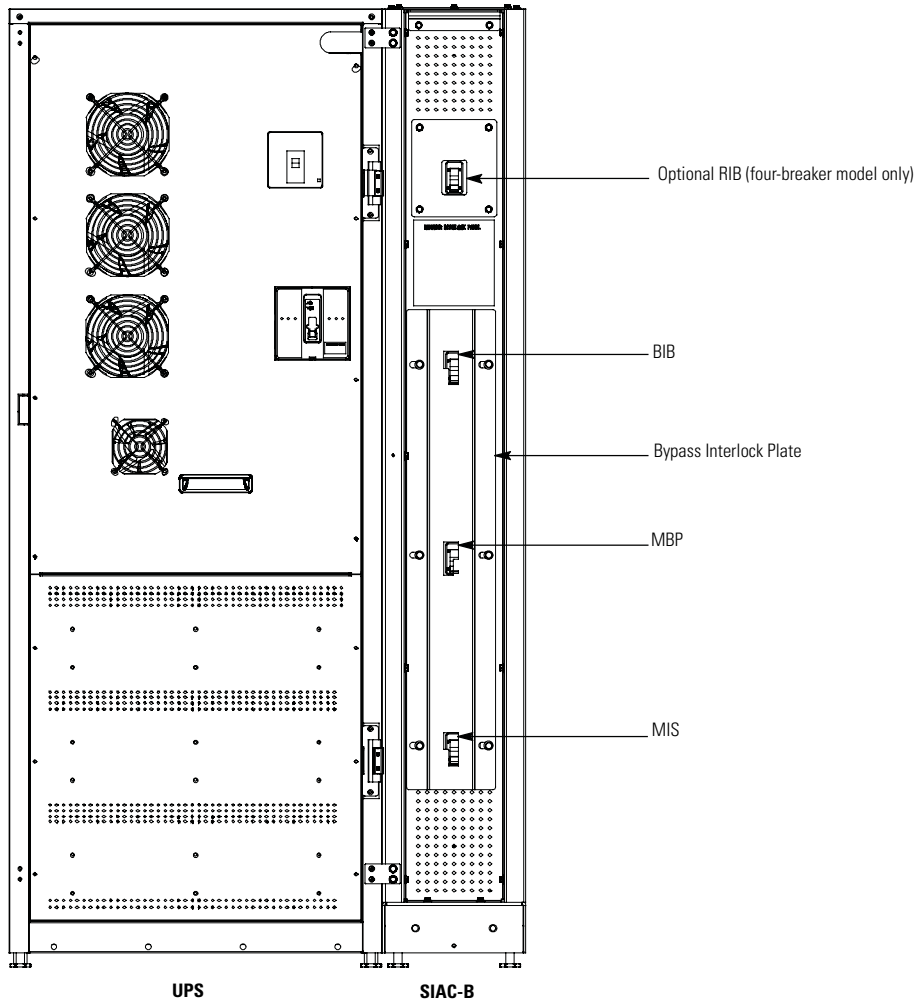
---

### 6.1 Circuit Breakers

Figure 6-1 and Figure 6-2 identify and show the location of the circuit breakers in the SIAC-B. The descriptions provide a brief overview of the SIAC-B breaker use.

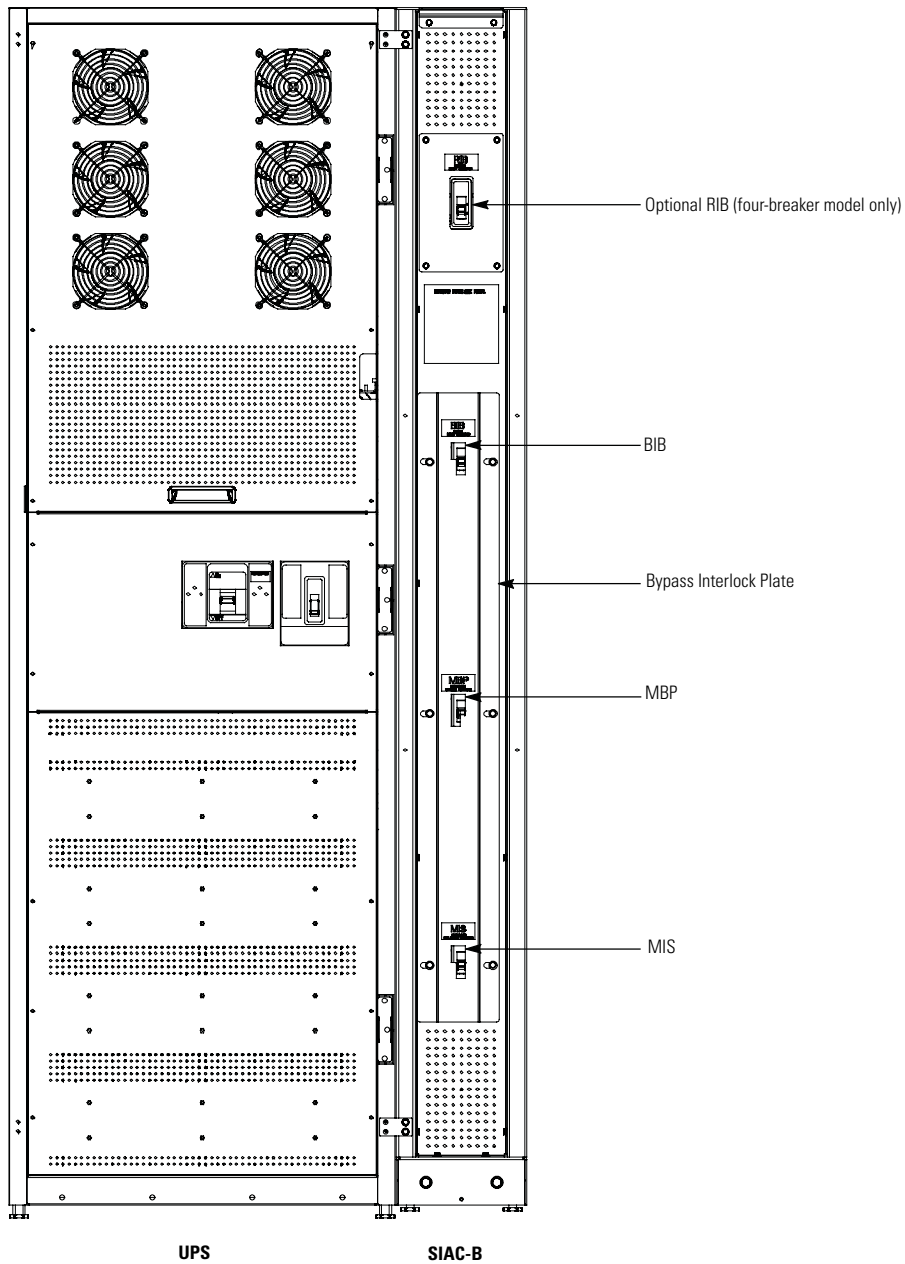
- **Maintenance Bypass Breaker** – The Maintenance Bypass Breaker (MBP) transfers the load from the UPS output to the bypass input feeder.
- **Maintenance Isolation Breaker** – The Maintenance Isolation Breaker (MIS) isolates the UPS from the bypass feed and the load.
- **Bypass Input Breaker** – The Bypass Input Breaker (BIB) provides a single point of input power control to the UPS on single-feed systems or bypass input power control to the UPS on dual-feed systems. Using the BIB easily removes power from the UPS for servicing.
- **Rectifier Input Breaker** – The optional Rectifier Input Breaker (RIB) (four-breaker version only) provides a single point of rectifier input power control to the UPS on dual-feed systems and easily removes power from the UPS for servicing.

# Sidecar Integrated Accessory Cabinet-Bypass Operating Instructions



**NOTE** The 93E 30 kVA UPS is shown with a right-mounted SIAC-B. An UPS with a left-mounted SIAC-B is the mirror image.

**Figure 6-1. 93E 30SIAC-B Breakers**



**NOTE** The 93E 60 kVA UPS is shown with a right-mounted SIAC-B. An UPS with a left-mounted SIAC-B is the mirror image.

**Figure 6-2. 93E 60SIAC-B Breakers**

## 6.2 Operation

### 6.2.1 Using the UPS when an SIAC-B is Installed

To operate the SIAC-B:

1. Loosen the captive thumb screw securing the bottom of the SIAC-B front panel. Lift the panel straight up to remove it from the panel hanger bracket at the top of the cabinet.
2. Close the SIAC-B bypass input feeder circuit breaker.
3. If an RIB is installed, close the SIAC-B rectifier input feeder breaker.
4. Verify that the SIAC-B circuit breakers are set as follows (see Figure 6-1 or Figure 6-2 for breaker locations):

MBP	<b>OPEN</b>
MIS	<b>CLOSED</b>
BIB	<b>CLOSED</b>
RIB (if installed)	<b>CLOSED</b>

5. Start the UPS. Refer to the applicable Eaton 93E UPS Installation and Operation manual listed in paragraph 1.7, for UPS operating procedures.
6. Reinstall the SIAC-B front panel and secure with captive thumb screw.

### 6.2.2 Transferring the UPS to Maintenance Bypass using an SIAC-B

---

 **CAUTION**

---

Only trained personnel familiar with the operation of this equipment should transfer loads. Failure to follow this transfer sequence may cause loss of power to loads.

---



---

 **CAUTION**

---

In Bypass mode, the critical load is not protected from commercial power interruptions and abnormalities.

---

To transfer the load to maintenance bypass:

1. Loosen the captive thumb screw securing the bottom of the SIAC-B front panel. Lift the panel straight up to remove it from the panel hanger bracket at the top of the cabinet.
2. Transfer the UPS from normal mode to bypass mode. Refer to the applicable Eaton 93E UPS Installation and Operation manual listed in paragraph 1.7 for UPS operating procedures.

---

 **CAUTION**

---

Failure to close the MBP before opening the Maintenance Isolation Breaker (MIS) will result in the loss of power to the critical load.

---

3. Close the MBP
4. Slide the bypass interlock plate to the left (see Figure 6-1 or Figure 6-2).
5. Open the MIS.

The critical load is supplied by the maintenance bypass source.



---

 **WARNING**

---

The BIB and RIB (if installed) must be opened to electrically isolate the UPS.

---

6. Open the BIB.
7. Open the RIB (if installed).
8. Reinstall the SIAC-B front panel and secure with captive thumb screw.
9. Shut down the UPS. Refer to the applicable Eaton 93E UPS Installation and Operation manual listed in paragraph 1.7 for UPS operating procedures.

### **6.2.3 Transferring the UPS from Maintenance Bypass using an SIAC-B**

---

 **CAUTION**

---

Only trained personnel familiar with the operation of this equipment should transfer loads. Failure to follow this transfer sequence may cause loss of power to loads.

---

To transfer the load from maintenance:

1. Loosen the captive thumb screw securing the bottom of the SIAC-B front panel. Lift the panel straight up to remove it from the panel hanger bracket at the top of the cabinet.
2. Close the BIB.
3. Close the RIB (if installed).
4. Start the UPS in bypass mode. Refer to the applicable Eaton 93E UPS Installation and Operation manual listed in paragraph 1.7 for UPS operating procedures.

---

 **CAUTION**

---

Failure to close the MIS before opening the MBP will result in the loss of power to the critical load.

---

5. Close the MIS.
6. Slide the bypass interlock plate to the right (see Figure 6-1 or Figure 6-2).
7. Open the MBP.
8. Reinstall the SIAC-B front panel and secure with captive thumb screw.
9. Transfer the UPS to Normal mode. Refer to the applicable Eaton 93E UPS Installation and Operation manual listed in paragraph 1.7 for UPS operating procedures.

This page intentionally left blank.

## Chapter 7 Maintenance

The components inside the Sidecar Integrated Accessory Cabinets (SIACs) are secured to a sturdy metal frame. All repairable parts and assemblies are located for easy removal, with very little disassembly. This design allows authorized service personnel to perform routine maintenance and servicing quickly.

You must schedule periodic performance checks of the UPS system to keep it running properly. Regular routine checks of operation and system parameters enable your system to function efficiently for many trouble-free years.

### 7.1 Important Safety Instructions

Remember that your UPS system is designed to supply power **EVEN WHEN DISCONNECTED FROM THE UTILITY POWER.**

---

 **WARNING**

---

- No user serviceable components.
  - Servicing and maintenance should be performed by qualified service personnel only.
  - **LETHAL VOLTAGE PRESENT.** This unit should not be operated with the cabinet doors open or protective panels removed. Do not make any assumptions about the electrical state of any cabinet in the UPS system.
- 

### 7.2 Performing Preventive Maintenance

The UPS system requires very little preventive maintenance. However, the system should be inspected periodically to verify that the units are operating normally. Record maintenance results and any corrective actions in a suitable log.

#### 7.2.1 DAILY Maintenance

Perform the following steps daily:

1. Check the area surrounding the UPS system. Ensure the area is not cluttered, allowing free access to the unit.
2. Ensure the air intakes on the Accessory cabinets are not blocked.
3. Ensure the operating environment is within the parameters specified in paragraph 3.2.1 and Chapter 8, "Product Specifications."

#### 7.2.2 PERIODIC Maintenance

Periodic inspections of the IACs should be made to determine if components, wiring, and connections exhibit evidence of overheating. Particular attention should be given to the compression lug connections. Maintenance procedures should specify that the compression lug connections be retorqued to values listed in this manual.

#### 7.2.3 ANNUAL Maintenance

Annual preventive maintenance should be performed only by authorized service personnel familiar with maintenance and servicing of the UPS system. Contact an Eaton service representative for more information about service offerings.

### 7.3 Maintenance Training

A basic training course, available from Eaton Corporation, gives you a competent working knowledge of the UPS system operation and teaches you how to perform first level corrective maintenance. For more information about training and other services, contact the Help Desk (see paragraph 1.7).

This page intentionally left blank.

## Chapter 8 Product Specifications

This section provides the following specifications:

- Model Numbers
- Input specifications
- Output specifications
- Environmental and safety specifications

### 8.1 Model Numbers

The Sidecar Integrated Accessory Cabinets (SIACs) are available in the models listed below to meet the needs of the Eaton 93E UPS product line.

Sidecar Integrated Accessory Cabinet Models	Description
Eaton 93E 30SIAC-B	SIAC-B for Eaton 93E 30kVA UPS
Eaton 93E 60SIAC-B	SIAC-B for Eaton 93E 60kVA UPS

### 8.2 Specifications

The following sections detail the input, output, and environmental and safety specifications for the SIACs.

#### 8.2.1 Input

<b>Operating Input Voltage Range</b>	208/120 Vac nominal (60 Hz)
<b>Input Wiring: 4W + G</b> <b>Operating Frequency Range</b>	60 Hz $\pm$ 5 Hz
<b>Operating Input Current</b>	See Tables 3-2 or 3-3

#### 8.2.2 Output

<b>Operating Output Voltage</b>	208/120 Vac nominal
<b>Output Wiring: 4W + G</b> <b>Operating Output Frequency Range</b>	60 Hz $\pm$ 5 Hz
<b>Output Current</b>	See Tables 3-2 or 3-3

#### 8.2.3 Environmental and Safety Specifications

<b>Operating Temperature</b>	32°F to 86°F (0°C to 30°C).
<b>Transit Temperature</b>	-13°F to 140°F (-25°C to 60°C)
<b>Storage Temperature</b>	-13°F to 131°F (-25°C to 55°C)
<b>Operating Altitude</b>	Maximum 1500m (5000 ft) at 30°C without derating
<b>Transit Altitude</b>	15000m (49213 ft)
<b>Ventilation</b>	Convection
<b>Relative Humidity (operating and storage)</b>	5% to 95% maximum noncondensing
<b>Acoustical Noise</b>	Not applicable
<b>Safety Conformance</b>	UL1778 4 <sup>th</sup> edition
<b>Agency Markings</b>	cULus

This page intentionally left blank.

## Warranty

### LIMITED FACTORY WARRANTY FOR THREE-PHASE EATON® 93E UPS AND 93E UPS ACCESSORY PRODUCTS

**WARRANTOR:** The warrantor for the limited warranties set forth herein is Eaton Corporation, an Ohio Corporation ("Eaton").

**LIMITED WARRANTY:** This limited warranty (this "Warranty") applies only to the original end-user (the "End-User") of the Eaton Three-Phase 93E UPS and 93E UPS Accessory Products (the "Product") and cannot be transferred. This restriction applies even in the event that the Product is initially sold by Eaton for resale to an End-User. This Warranty gives you specific legal rights, and you may also have other rights which vary from State to State (or jurisdiction to jurisdiction).

**WHAT THIS LIMITED WARRANTY COVERS:** The warrantor warrants, with the terms of this Warranty, that the Eaton three-phase UPS electronics, Eaton-built accessories, and Eaton -built battery cabinets (individually and collectively, the "Warranted Items") are free from defects in material and workmanship.

For Product installed (and currently located) in the fifty (50) United States and the District of Columbia, if, in the opinion of Eaton, a Warranted Item is defective, Eaton's sole obligation, at the option of Eaton, will be to refurbish or replace such defective Warranted Item (including the costs of providing diagnosis, service, and labor ["labor coverage"]). The defective Warranted Item will be refurbished or replaced onsite at the End-User's location or such other location as determined by Eaton. Any parts that are replaced may be new or reconditioned. All parts replaced by Eaton shall become the property of Eaton.

For Product installed (and currently located) outside the fifty (50) United States and the District of Columbia, if, in the opinion of Eaton, a Warranted Item is defective, Eaton's sole obligation, at the option of Eaton, will be to refurbish or replace such defective Warranted Item (not including the costs of labor coverage). The defective Warranted Item will be refurbished or replaced onsite at the End-User's location or such other location as determined by Eaton. Any parts that are replaced may be new or reconditioned. All parts replaced by Eaton shall become the property of Eaton.

**LIMITED WARRANTY PERIOD:** The period covered by this Warranty for Product installed (and currently located) in the fifty (50) United States and the District of Columbia is six (6) months from the date of Product purchase for labor coverage when no startup is performed by an authorized Eaton Customer Service Engineer or Agent or twelve (12) months from the date of Product purchase with startup performed by an authorized Eaton Customer Service Engineer or Agent and twelve (12) months from the date of Product purchase or eighteen (18) months from date of Product shipment, whichever occurs first, for the refurbishment/ replacement of parts.

The period covered by this Warranty for Product installed (and currently located) outside the fifty (50) United States and the District of Columbia is twelve (12) months from the date of Product purchase or eighteen (18) months from the date of Product shipment, whichever occurs first, for the refurbishment/replacement of parts.

**WHAT THIS LIMITED WARRANTY DOES NOT COVER:** This Warranty does not cover any defects or damages caused by: (a) failure to properly store the Product before installation, including the "trickle charge" of batteries no later than the date indicated on the packaging; (b) shipping and delivery of the Product if shipping is FOB Factory; (c) neglect, accident, fire, flood, lightning, vandalism, acts of God, Customer's neglect, abuse, misuse, misapplication, incorrect installation; (d) repair or alteration not authorized in writing by Eaton personnel or performed by an authorized Eaton Customer Service Engineer or Agent; or (e) improper testing, operation, maintenance, adjustment, or any modification of any kind not authorized in writing by Eaton personnel or performed by an authorized Eaton Customer Service Engineer or Agent.

This Warranty is not valid: if the Product's serial numbers have been removed or are illegible. Any Warranted Items repaired or replaced pursuant to this Warranty will be warranted for the remaining portion of the original Warranty subject to all the terms thereof. Eaton does not provide a labor warranty for Product located outside of the fifty (50) United States or the District of Columbia. **Any equipment, parts, or materials included in the Product and not manufactured by Eaton are warranted solely by the manufacturer of such equipment, parts, or materials and are not included as part of this Warranty. Batteries are not warranted by Eaton.**

**THIS WARRANTY IS THE END-USER'S SOLE REMEDY AND IS EXPRESSLY IN LIEU OF, AND THERE ARE NO OTHER, EXPRESSED OR IMPLIED GUARANTEES OR WARRANTIES (INCLUDING ANY IMPLIED WARRANTY OF MERCHANTABILITY OR FITNESS FOR ANY PURPOSE, WHICH ARE EXPRESSLY DISCLAIMED). SOME STATES OR JURISDICTIONS DO NOT ALLOW THE EXCLUSION OF EXPRESS OR IMPLIED WARRANTIES, SO THE ABOVE EXCLUSION MAY NOT APPLY TO YOU. IN THAT EVENT, SUCH WARRANTIES ARE LIMITED IN DURATION TO THE LIMITED WARRANTY PERIOD. SOME STATES OR JURISDICTIONS DO NOT ALLOW LIMITATIONS ON HOW LONG AN IMPLIED WARRANTY LASTS OR THE EXCLUSION OR LIMITATION OF INCIDENTAL OR CONSEQUENTIAL DAMAGES, SO THE ABOVE LIMITATIONS AND/OR EXCLUSIONS MAY NOT APPLY TO YOU.**

**LIMITATION OF LIABILITY:** In no event shall Eaton be liable for any indirect, incidental, special or consequential damages of any kind or type whatsoever, resulting from or in connection with any claim or cause of action, whether brought in contract or in tort (including negligence and strict liability). Some States or jurisdictions do not allow the exclusion of limitation of incidental or consequential damages, so the above limitation or exclusion may not apply to you. Eaton shall not be responsible for failure to provide service or parts due to causes beyond Eaton's reasonable control. In no case will Eaton's liability under this Warranty exceed the replacement value of the Warranted Items.

**END-USER'S OBLIGATIONS:** In order to receive the benefits of this Warranty, the End-User must register the product warranty (via mail or online at [www.powerquality.eaton.com/Product-Registration](http://www.powerquality.eaton.com/Product-Registration) "product registration"); use the Product in a normal way; follow the Product's user's guide; and protect against further damage to the Product if there is a covered defect.

**OTHER LIMITATIONS:** Eaton's obligations under this Warranty are expressly conditioned upon receipt by Eaton of all payments due to it (including interest charges, if any). During such time as Eaton has not received payment of any amount due to it for the Product, in accordance with the contract terms under which the Product is sold, Eaton shall have no obligation under this Warranty. Also during such time, the period of this Warranty shall continue to run and the expiration of this Warranty shall not be extended upon payment of any overdue or unpaid amounts.

**COSTS NOT RELATED TO WARRANTY:** The End-User shall be invoiced for, and shall pay for, all services not expressly provided for by the terms of this Warranty, including without limitation site calls involving an inspection that determines no corrective maintenance is required. Any costs for replacement equipment, installation, materials, freight charges, travel expenses, or labor of Eaton representatives outside the terms of this Warranty will be borne by the End-User.

**OBTAINING WARRANTY SERVICE:** In the USA, call the Eaton Customer Reliability Center 7x24 at 800-843-9433. Outside of the USA, call your local Eaton sales or service representative, or call the Eaton Customer Reliability Center in the United States at 919-845-3633. For comments or questions about this Limited Factory Warranty, write to the Customer Quality Representative, 8609 Six Forks Road, Raleigh, North Carolina 27615 USA.







P-164000303 2