

Eaton® 93E Integrated Transformer Cabinet

30ITC and 60ITC
Installation Manual



Powering Business Worldwide

Eaton® 93E Integrated Transformer Cabinet

30ITC and 60ITC
Installation Manual



Powering Business Worldwide

IMPORTANT SAFETY INSTRUCTIONS SAVE THESE INSTRUCTIONS

This manual contains important instructions that should be followed during installation and maintenance of the UPS system and batteries. Read all instructions before operating the equipment and save this manual for future reference.

CONSIGNES DE SÉCURITÉ IMPORTANTES CONSERVER CES INSTRUCTIONS

Ce manuel comporte des instructions importantes que vous êtes invité à suivre lors de toute procédure d'installation et de maintenance des batteries et de l'onduleur. Veuillez consulter entièrement ces instructions avant de faire fonctionner l'équipement et conserver ce manuel afin de pouvoir vous y reporter ultérieurement.

Eaton is a registered trademarks of Eaton Corporation or its subsidiaries and affiliates. National Electrical Code and NEC are registered trademarks of National Fire Protection Association, Inc. All other trademarks are property of their respective companies.

©Copyright 2011–2015 Eaton Corporation, Raleigh, NC, USA. All rights reserved. No part of this document may be reproduced in any way without the express written approval of Eaton Corporation.

Table of Contents

1	INTRODUCTION	1-1
1.1	Installation Features	1-2
1.2	Model Configurations	1-2
1.3	Using This Manual	1-4
1.4	Conventions Used in This Manual	1-4
1.5	Symbols, Controls, and Indicators	1-4
1.6	For More Information	1-5
1.7	Getting Help	1-5
2	SAFETY WARNINGS	2-1
3	INSTALLATION PLAN AND UNPACKING	3-1
3.1	Creating an Installation Plan	3-1
3.2	Preparing the Site	3-1
3.2.1	Environmental and Installation Considerations	3-1
3.2.2	ITC Power Wiring Preparation	3-9
3.3	Inspecting and Unpacking the ITC	3-14
3.4	Transformer Breaker Location	3-16
4	INSTALLATION	4-1
4.1	Preliminary Installation Information	4-1
4.2	Unloading the ITC from the Pallet	4-1
4.2.1	Unloading the 30ITC	4-1
4.2.2	Unloading the 60ITC	4-5
4.3	Installing the Power Terminal Cover Base	4-8
4.4	Installing ITC External Power Wiring	4-10
4.4.1	Single-Feed UPS with Input Transformer	4-10
4.4.2	Single-Feed UPS with Input and Output Transformers	4-20
4.4.3	Dual-Feed UPS with Two Input Transformers	4-23
4.4.4	Dual-Feed UPS with Two Input Transformers and One Output Transformer	4-24
4.5	Initial Startup	4-27
4.6	Completing the Installation Checklist	4-27
5	ONELINES AND SCHEMATICS	5-1
5.1	Onelines	5-1
5.2	Schematics	5-3
6	MAINTENANCE	6-1
6.1	Important Safety Instructions	6-1
6.2	Performing Preventive Maintenance	6-1
6.2.1	DAILY Maintenance	6-1
6.2.2	PERIODIC Maintenance	6-1
6.2.3	ANNUAL Maintenance	6-1
6.3	Recycling the ITC	6-2
6.4	Maintenance Training	6-2

Table of Contents

7 PRODUCT SPECIFICATIONS..... 7-1

 7.1 Model Numbers 7-1

 7.2 Specifications 7-1

 7.2.1 Input Transformer 7-1

 7.2.2 Output Transformer..... 7-1

 7.2.3 Environmental and Safety Specifications 7-2

WARRANTY..... W-1

List of Figures

Figure 1-1.	Eaton 93E 30ITC and Eaton 93E 60ITC	1-1
Figure 1-3.	Eaton 93E 60 kVA UPS and Eaton 93E 60ITC	1-3
Figure 3-1.	93E 30ITC Cabinet Dimensions (Front, Right Side, and Rear Views)	3-3
Figure 3-2.	93E 30ITC Dimensions (Top and Bottom Views)	3-4
Figure 3-3.	93E 30ITC Center of Gravity	3-5
Figure 3-4.	93E 60ITC Cabinet Dimensions (Front, Right Side, and Rear Views)	3-6
Figure 3-5.	93E 60ITC Dimensions (Top and Bottom Views)	3-7
Figure 3-6.	93E 60ITC Center of Gravity	3-8
Figure 3-7.	Eaton 93E 30ITC and Eaton 93E 60ITC as Shipped on Pallet	3-15
Figure 3-8.	Eaton 93E 30ITC and Eaton 93E 60ITC Transformer Breaker Locations – Front Views with Doors Removed	3-16
Figure 4-1.	Removing the Front Shipping Bracket – 93E 30ITC	4-2
Figure 4-2.	Removing the Rear Shipping Bracket – 93E 30ITC	4-3
Figure 4-3.	Installing the Pallet Extension Plate – 93E 30ITC	4-4
Figure 4-4.	Removing the Pallet Skids and Supports – 93E 60ITC	4-7
Figure 4-5.	ITC Power Terminal Cover Parts	4-8
Figure 4-6.	Eaton 93E 30ITC Power Terminal Cover Base Installation and Conduit Wire Entry Location	4-9
Figure 4-7.	Eaton 93E 60ITC Power Terminal Cover Base Installation and Conduit Wire Entry Location	4-10
Figure 4-8.	Wire Tray Location – 93E 30ITC	4-12
Figure 4-9.	Wire Tray Location – 93E 60ITC	4-13
Figure 4-10.	Input and Output Power Terminal Locations – 93E 30ITC	4-14
Figure 4-11.	Output Transformer Breaker Terminal Detail – 93E 30ITC	4-15
Figure 4-12.	Input Transformer Breaker Terminal Detail – 93E 30ITC	4-15
Figure 4-13.	Input and Output Power Terminal Locations – 93E 60ITC	4-16
Figure 4-14.	Output Transformer Breaker Terminal Detail – 93E 60ITC	4-17
Figure 4-15.	Input Transformer Breaker Terminal Detail – 93E 60ITC	4-17
Figure 4-16.	ITC and UPS Power Terminal Cover Base Wiring Channel	4-18
Figure 4-17.	ITC Power Terminal Cover Install	4-19
Figure 4-18.	ITC Power Terminal Cover Splice Installation	4-20
Figure 5-1.	93E 30ITC and 93E 60ITC Internal Oneline	5-1
Figure 5-2.	Dual Transformer 93E 30ITC and 93E 60ITC Intercabinet Interconnection Oneline	5-2
Figure 5-3.	93E 30ITC and 93E 60ITC Schematic	5-3

This page intentionally left blank.

List of Tables

Table 3-1.	ITC Weights	3-2
Table 3-2.	ITC Clearances	3-2
Table 3-3.	Cooling Requirements During Full Load Operation	3-2
Table 3-4.	External Power Wiring Requirements for the Eaton 93E 30ITC and 93E 60ITC – Single Transformer	3-10
Table 3-5.	External Power Wiring Requirements for the Eaton 93E 30ITC and 93E 60ITC – Dual Transformer	3-11
Table 3-6.	External Input Power Cable Terminations for the Eaton 93E 30ITC – Single Transformer	3-12
Table 3-7.	External Input Power Cable Terminations for the Eaton 93E 30ITC – Dual Transformer	3-12
Table 3-8.	External Input Power Cable Terminations for the Eaton 93E 60ITC – Single Transformer	3-13
Table 3-9.	External Input Power Cable Terminations for the Eaton 93E 60ITC – Dual Transformer	3-13

This page intentionally left blank.

Chapter 1 Introduction

The Eaton® Integrated Transformer Cabinet (ITC) provides voltage transformation and isolation for the 93E 20–30 kVA and 40–60 kVA Uninterruptible Power Supply (UPS) to enhance the usability and reliability of the systems. Two models are available, the 93E 30ITC and 93E 60ITC to match the installed Eaton 93E UPS.

A 480/208 Vac input isolation transformer provides an isolated input to the UPS rectifier for applications that require an input of 480 Vac.

An optional 208/480 Vac output isolation transformer provides an isolated output to the critical load or for applications that require 480 Vac. To save space, the transformer is contained in the same ITC as the input transformer.

The ITC is housed in a single free-standing cabinet with a safety shield behind the door for hazardous voltage protection. The cabinets match the UPS cabinet in style and color.

Figure 1-1 shows the Eaton 93E 30ITC and Eaton 93E 60ITC.

NOTE Startup and operational checks must be performed by an authorized Eaton Customer Service Engineer, or the warranty terms specified on page W-1 become void. This service is offered as part of the sales contract for the UPS. Contact an Eaton service representative in advance (usually a two-week notice is required) to reserve a preferred startup date.

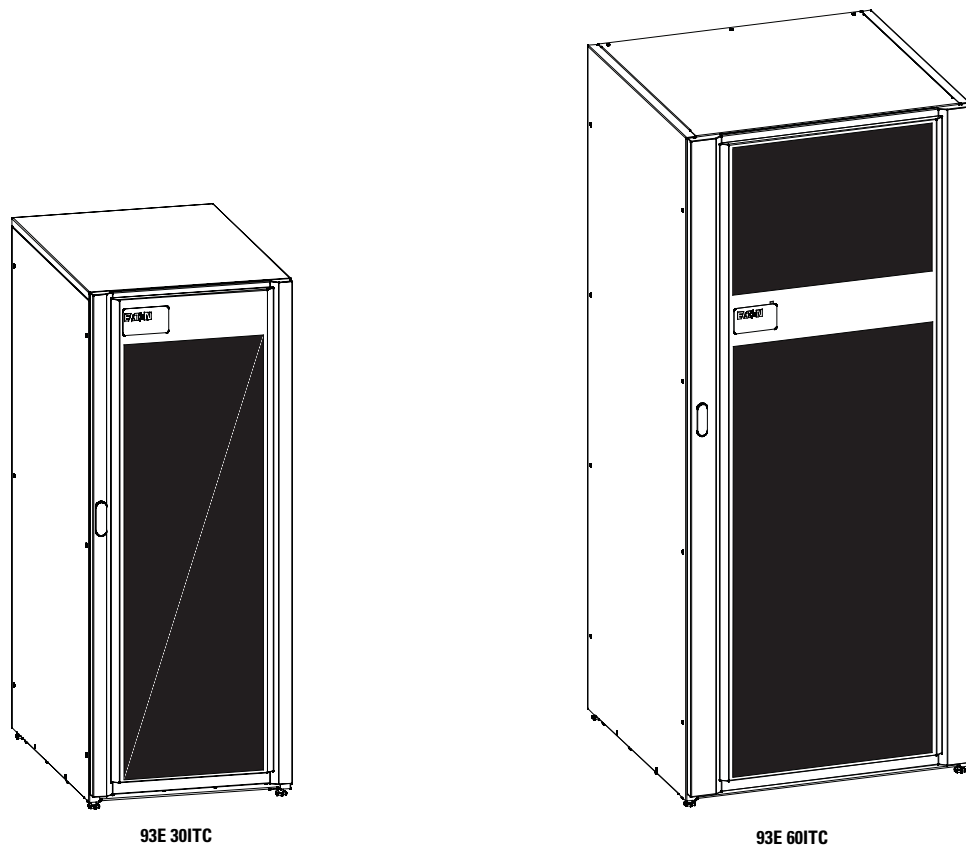

Figure 1-1. Eaton 93E 30ITC and Eaton 93E 60ITC

1.1 Installation Features

The ITC is designed to be installed in a line-up-and-match or standalone configuration. In a line-up-and-match configuration power wiring may be routed either external to the cabinet using conduit or the power terminal wiring channel assembly may be utilized to pass wiring between adjacent cabinets. In standalone configurations power wiring is routed using external conduit.

To reduce installation time, wiring enters the ITC from the back and is routed to the front panel for easy connection to the mechanical lugs located on the input and output circuit breakers.

A line-up-and-match ITC is installed adjacent to the UPS or other accessory cabinet. The recommended installation location is to the left of the UPS cabinet. See Figure 1-2 and Figure 1-3 for line-up-and-match configuration views.

1.2 Model Configurations

The following model configurations are available:

- 93E 30ITC for use with the 93E 30 kVA UPS
 - Single Transformer Cabinet: Contains a three-phase 480 Vac to 208Y/120 Vac input isolation transformer
 - Dual Transformer Cabinet: Contains a three-phase 480 Vac to 208Y/120 Vac input isolation transformer and a three-phase 208 Vac to 480Y/277 Vac output isolation transformer
- 93E 60ITC for use with the 93E 60 kVA UPS
 - Single Transformer Cabinet: Contains a three-phase 480 Vac to 208Y/120 Vac input isolation transformer
 - Dual Transformer Cabinet: Contains a three-phase 480 Vac to 208Y/120 Vac input isolation transformer and a three-phase 208 Vac to 480Y/277 Vac output isolation transformer

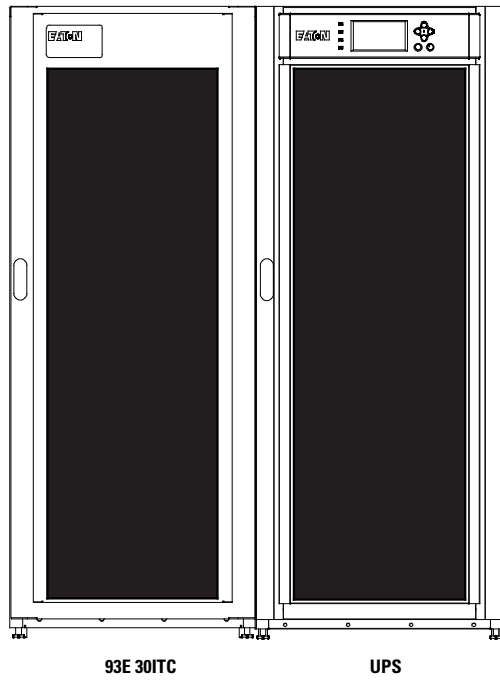

Figure 1-2. Eaton 93E 30 kVA UPS and Eaton 93E 30ITC

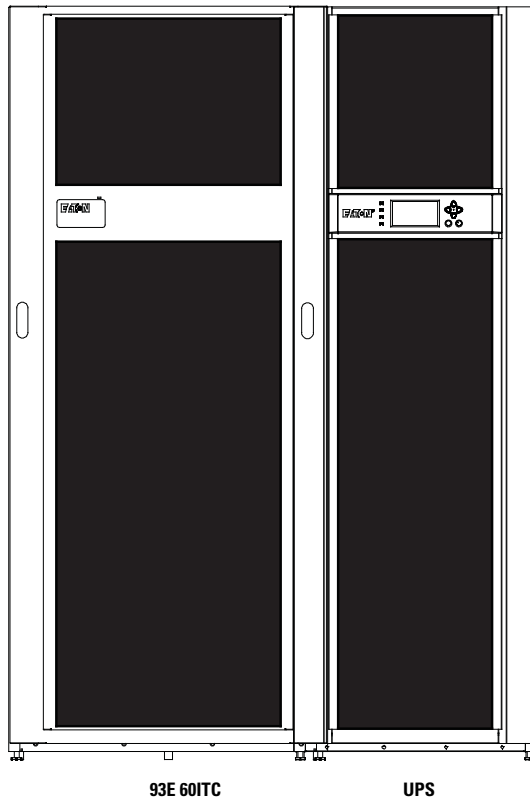

Figure 1-3. Eaton 93E 60 kVA UPS and Eaton 93E 60ITC

1.3 Using This Manual

This manual describes how to install the ITC. Read and understand the procedures described to ensure trouble-free installation and operation.

Read through each procedure before beginning the procedure. Perform only those procedures that apply to the UPS system being installed or operated.

1.4 Conventions Used in This Manual

This manual uses these type conventions:

- **Bold type** highlights important concepts in discussions, key terms in procedures, and menu options, or represents a command or option that you type or enter at a prompt.
- *Italic* type highlights new terms where they are defined.
- `Screen type` represents information that appears on the screen or LCD.

Icon	Description
NOTE	Information notes call attention to important features or instructions.
[Keys]	Brackets are used when referring to a specific key, such as [Enter] or [Ctrl].

In this manual, the term UPS refers only to the UPS cabinet and its internal elements. The term *UPS system* refers to the entire power protection system – the UPS cabinet, an external battery system, and options or accessories installed.

The term *line-up-and-match* refers to accessory cabinets that are physically located adjacent to the UPS. The term *standalone* refers to accessory cabinets that are located separate from the UPS.

1.5 Symbols, Controls, and Indicators

The following are examples of symbols used on the UPS or accessories to alert you to important information:



RISK OF ELECTRIC SHOCK - Observe the warning associated with the risk of electric shock symbol.



CAUTION: REFER TO OPERATOR'S MANUAL - Refer to your operator's manual for additional information, such as important operating and maintenance instructions.



This symbol indicates that you should not discard the UPS or the UPS batteries in the trash. This product contains sealed, lead-acid batteries and must be disposed of properly. For more information, contact your local recycling/reuse or hazardous waste center.



This symbol indicates that you should not discard waste electrical or electronic equipment (WEEE) in the trash. For proper disposal, contact your local recycling/reuse or hazardous waste center.

1.6 For More Information

Refer to the *Eaton 93E UPS (20-30 kVA, 208/220V) Generation 3 Installation and Operation Manual* or *Eaton 93E UPS (40-60 kVA, 208/220V) Generation 3 Installation and Operation Manual* for the following additional information:

- UPS, optional components, and accessory installation instructions, including site preparation, planning for installation, and wiring and safety information (detailed illustrations of cabinets and optional accessories with dimensional and connection point drawings are provided)
- UPS operation, including UPS controls, functions of the UPS, standard features and optional accessories, procedures for starting and stopping the UPS, and information about maintenance and responding to system events
- Communication capabilities of the UPS system

Refer to the *Eaton 93E Integrated Accessory Cabinet-Distribution Installation Manual* for the following additional information:

- Installation instructions, including site preparation, planning for installation, wiring and safety information, and detailed illustrations of cabinets with dimensional and connection point drawings

Refer to the *Eaton 93E Integrated Accessory Cabinet-Tie and Bypass Installation and Operation Manual* for the following additional information:

- Operation, including breakers, standard features and optional accessories, procedures for using the bypass functions, and information about maintenance
- Installation instructions, including site preparation, planning for installation, wiring and safety information, and detailed illustrations of cabinets with dimensional and connection point drawings

Visit www.eaton.com/powerquality or contact an Eaton service representative for information on how to obtain copies of these manuals.

1.7 Getting Help

If help is needed with any of the following:

- Scheduling initial startup
- Regional locations and telephone numbers
- A technical question about any of the information in this manual
- A question this manual does not answer

Please call the Customer Reliability Center at:

United States:	1-800-843-9433
Canada:	1-800-461-9166 ext 260
All other countries:	Call your local service representative

Please use the following e-mail address for manual comments, suggestions, or to report an error in this manual:

E-ESSDocumentation@eaton.com

This page intentionally left blank.

Chapter 2 Safety Warnings

IMPORTANT SAFETY INSTRUCTIONS SAVE THESE INSTRUCTIONS

This manual contains important instructions that should be followed during installation and maintenance of the UPS system and batteries. Read all instructions before operating the equipment and save this manual for future reference.

The UPS system is designed for industrial or computer room applications, and contains safety shields behind the door and front panels. However, the UPS system is a sophisticated power system and should be handled with appropriate care.

DANGER

This UPS system contains LETHAL VOLTAGES. All repairs and service should be performed by AUTHORIZED SERVICE PERSONNEL ONLY. There are NO USER SERVICEABLE PARTS inside the UPS.

WARNING

- The UPS system is powered by its own energy source (batteries). The output terminals may carry live voltage even when the UPS is disconnected from an AC source.
 - To reduce the risk of fire or electric shock, install this UPS system in a temperature and humidity controlled, indoor environment, free of conductive contaminants. Ambient temperature must not exceed 30°C (86°F). Do not operate near water or excessive humidity (95% maximum). The system is not intended for outdoor use.
 - As a result of the connected loads, high leakage current is possible. Connection to earth ground is required for safety and proper product operation. Do not check UPS system operation by any action that includes removal of the earth (ground) connection with loads attached.
 - Ensure all power is disconnected before performing installation or service.
 - ELECTRIC ENERGY HAZARD. Do not attempt to alter any UPS system or battery wiring or connectors. Attempting to alter wiring can cause injury.
-

CAUTION

- Installation or servicing should be performed by qualified service personnel knowledgeable of UPS and battery systems, and required precautions. Keep unauthorized personnel away from equipment. Consider all warnings, cautions, and notes before installing or servicing equipment.
 - Keep the Accessory cabinet doors closed and front panels installed to ensure proper cooling airflow and to protect personnel from dangerous voltages inside the unit.
 - Do not install or operate the UPS system close to gas or electric heat sources.
 - The operating environment should be maintained within the parameters stated in this manual.
 - Keep surroundings uncluttered, clean, and free from excess moisture.
 - Observe all DANGER, WARNING, and CAUTION notices affixed to the inside and outside of the equipment.
-

This page intentionally left blank.

Chapter 3 Installation Plan and Unpacking

Use the following basic sequence of steps to install the Eaton 93E 30 or Eaton 93E 60 Integrated Transformer Cabinet (ITC):

1. Create an installation plan for the ITC (Chapter 3).
2. Prepare your site for the ITC (Chapter 3).
3. Inspect and unpack the ITC (Chapter 3).
4. Unload and install the ITC, and wire the system (Chapter 4).
5. Complete the Installation Checklist (Chapter 4).
6. Have authorized service personnel perform preliminary operational checks and start up the system.

NOTE  Startup and operational checks must be performed by an authorized Eaton Customer Service Engineer, or the warranty terms specified on page W-1 become void. This service is offered as part of the sales contract for the UPS. Contact an Eaton service representative in advance (usually a two-week notice is required) to reserve a preferred startup date.

3.1 Creating an Installation Plan

Before installing the ITC, read and understand how this manual applies to the system being installed. Use the procedures and illustrations in this section to create a logical plan for installing the ITC. This section contains the following information:

- Physical features and requirements, including dimensions
- Power wiring installation notes
- Location of conduit and wire entry landing plates
- Location of power terminals

3.2 Preparing the Site

For the UPS system to operate at peak efficiency, the installation site should meet the environmental parameters outlined in this manual. If the UPS system is to be operated at an altitude higher than 1500m (5000 ft), contact an Eaton service representative for important information about high altitude operation. The operating environment must meet the weight, clearance, and environmental requirements specified for the applicable accessory cabinet.

3.2.1 Environmental and Installation Considerations

The UPS system installation, including the ITC, must meet the following guidelines:

- The system must be installed on a level floor suitable for computer or electronic equipment.
- The system must be installed in a temperature and humidity controlled indoor area free of conductive contaminants.

Failure to follow guidelines may void your warranty.

The ITC operating environment must accommodate the weight requirements shown in Table 3-1 and the size requirements shown in Figure 3-1 through Figure 3-6.

Table 3-1. ITC Weights

Model	Shipping	Weight kg (lb)	
		Installed	Point Loading
Eaton 93E 30ITC with Input Transformer	250 (551)	225 (496)	8 at 28 (62)
Eaton 93E 30ITC with Input and Output Transformer	403 (889)	378 (834)	8 at 47 (104)
Eaton 93E 60ITC with Input Transformer	450 (993)	416 (918)	12 at 35 (77)
Eaton 93E 60ITC with Input and Output Transformer	690 (1521)	656 (1446)	12 at 54 (120)

The 93E 30ITC uses forced air cooling and the 93E 60ITC uses convection cooling to regulate internal component temperature. Air inlets are in the front of the cabinet and outlets are in the back of the cabinet. Allow clearance in front of and in back of the cabinet for proper air circulation. The clearances required around the ITCs are shown in Table 3-2.

Table 3-2. ITC Clearances

From Top of Cabinet	304.8 mm (12") working space
From Front of Cabinet	914.4 mm (36") working space
From Back of Cabinet	914.4 mm (36") working space
From Right Side of Cabinet	None Required
From Left Side of Cabinet	None Required

The basic environmental requirements for operation of the ITC are:

- Recommended Operating Range: 15–25°C (59–77°F)
- Maximum Relative Humidity: 95%, noncondensing

The ITC cooling requirements are shown in Table 3-3.

Table 3-3. Cooling Requirements During Full Load Operation

Model	Rating kVA	Transformer Type	Voltage		Watts	Heat Rejection	
			Input	Output		BTU/hr x 1000	Kg-cal/hr
Eaton 93E 30ITC with Input Transformer	30	Input	480	208Y/120	2350	8.0	2022
Eaton 93E 30ITC with Input and Output Transformer	30	Input	480	208Y/120	3486	11.9	2999
		Output	208	480Y/277			
Eaton 93E 60ITC with Input Transformer	60	Input	480	208Y/120	2289	7.8	1970
Eaton 93E 60ITC with Input and Output Transformer	60	Input	480	208Y/120	5274	18.0	4538
		Output	208	480Y/277			

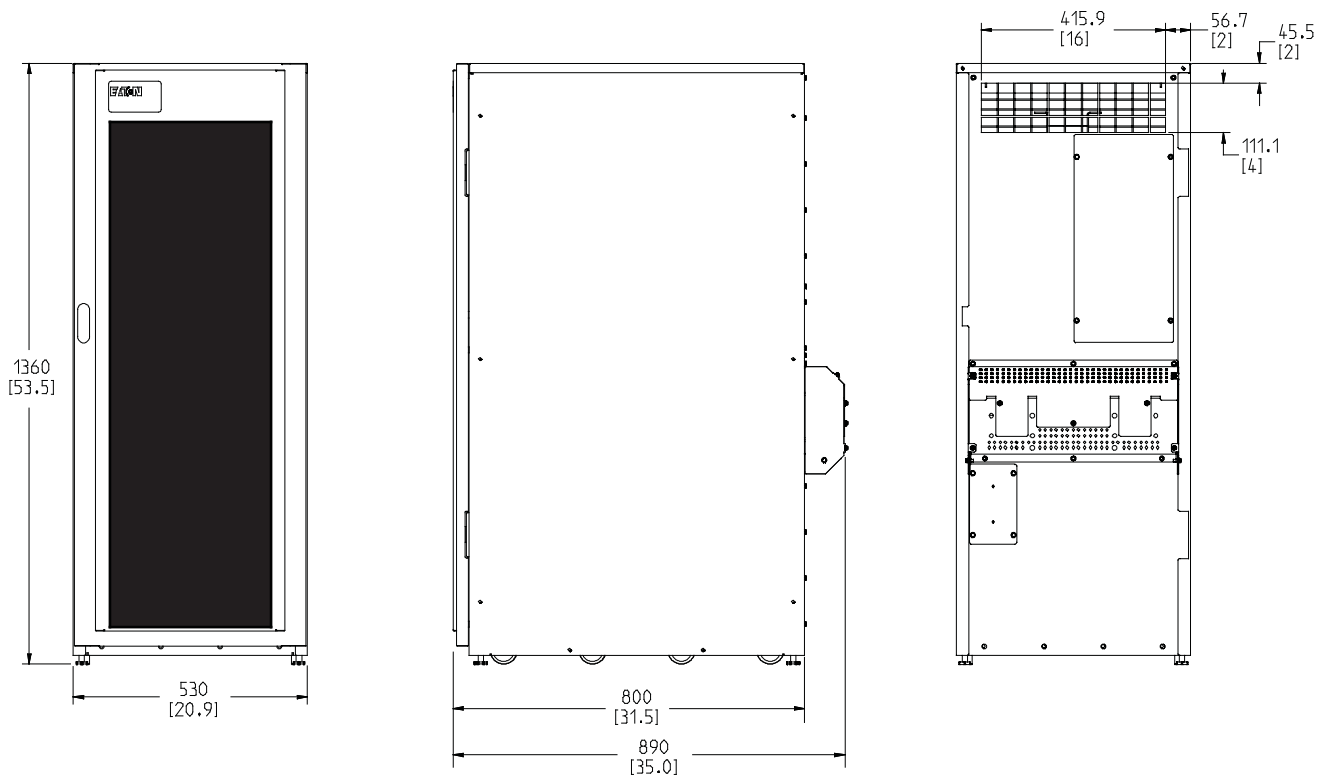

Dimensions are in millimeters [inches]

Figure 3-1. 93E 30ITC Cabinet Dimensions (Front, Right Side, and Rear Views)

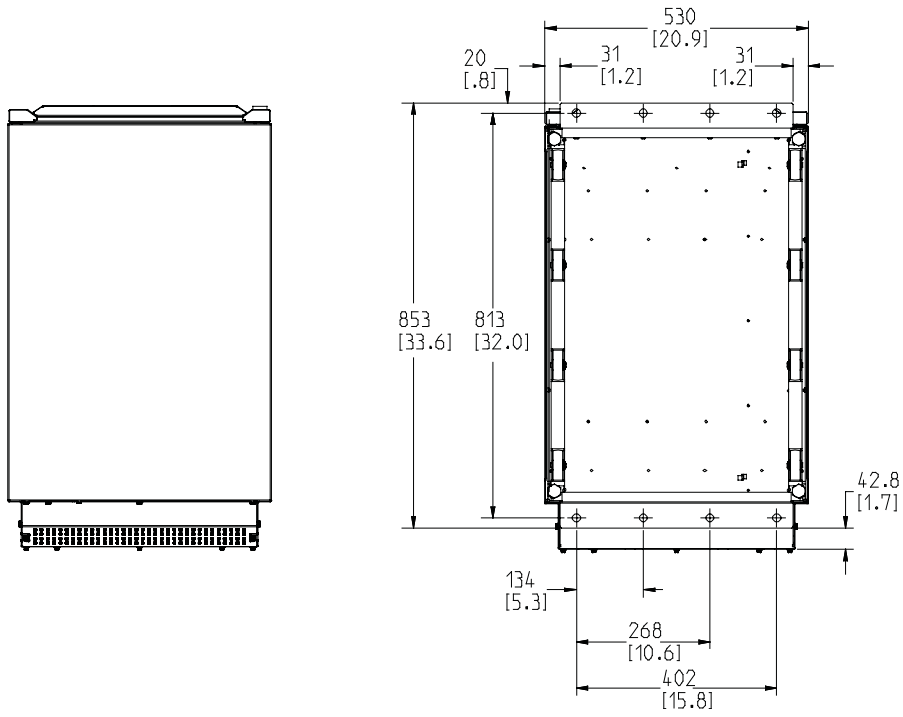

Dimensions are in millimeters [inches]

Figure 3-2. 93E 30ITC Dimensions (Top and Bottom Views)

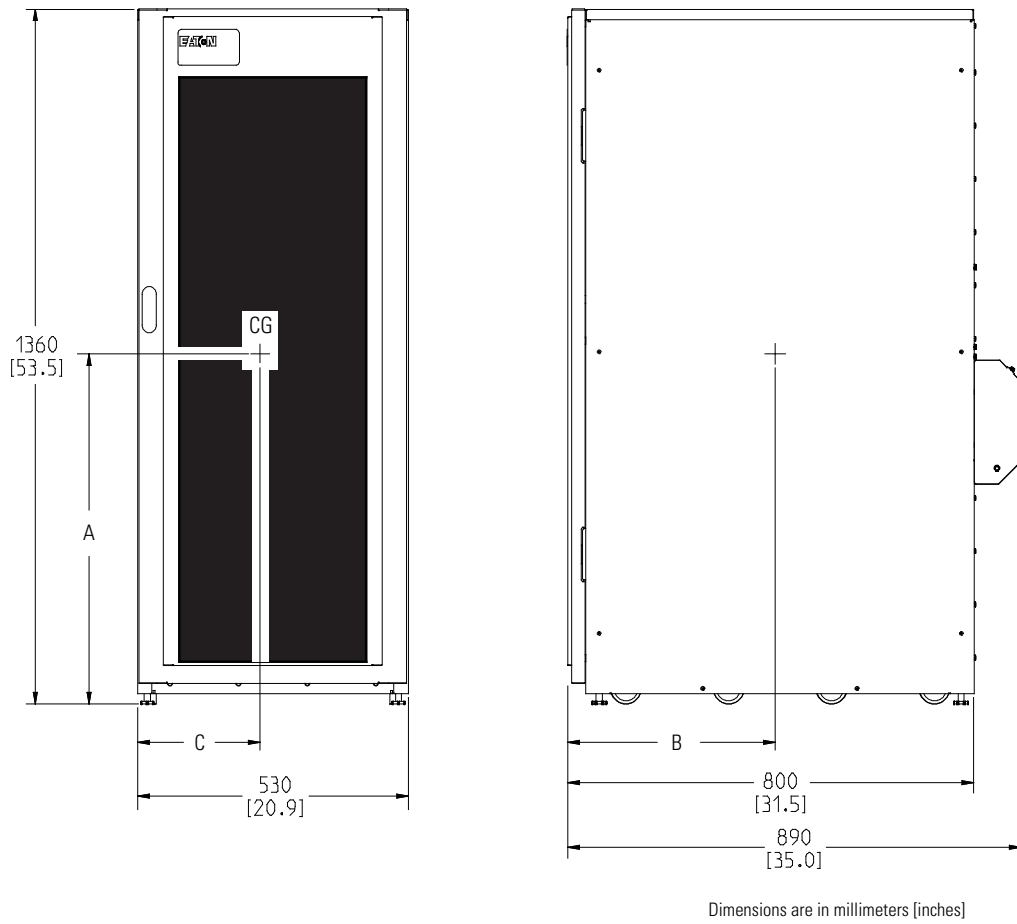

Center of Gravity			
	A	B	C
Single Transformer	425 (16.7)	416 (16.4)	280 (11.0)
Dual Transformer	675 (26.6)	416 (16.4)	270 (10.6)

Figure 3-3. 93E 30ITC Center of Gravity

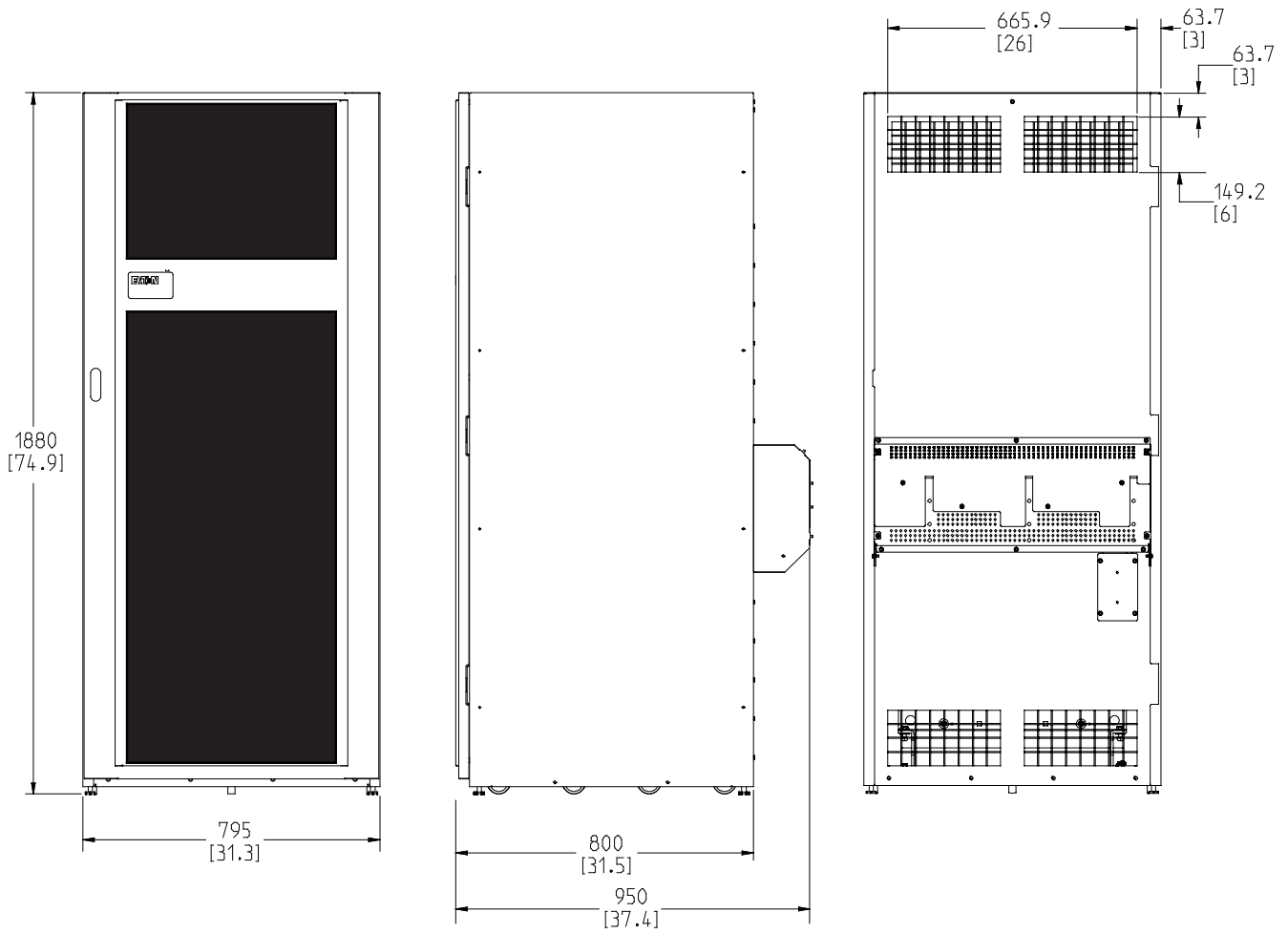

Dimensions are in millimeters [inches]

Figure 3-4. 93E 60ITC Cabinet Dimensions (Front, Right Side, and Rear Views)

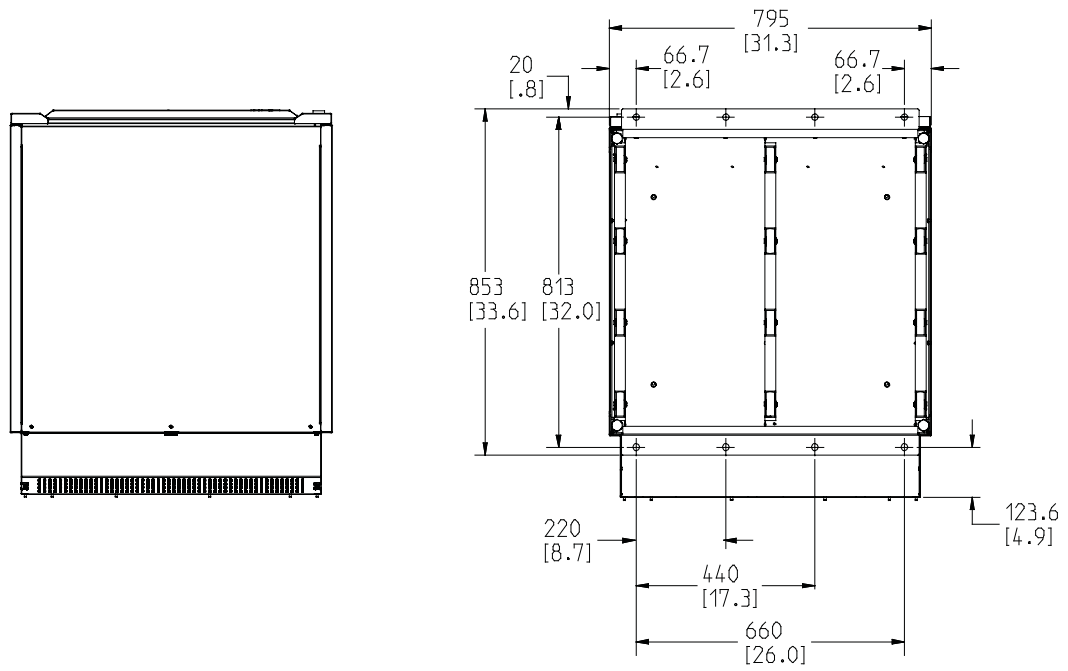

Dimensions are in millimeters [inches]

Figure 3-5. 93E 60ITC Dimensions (Top and Bottom Views)

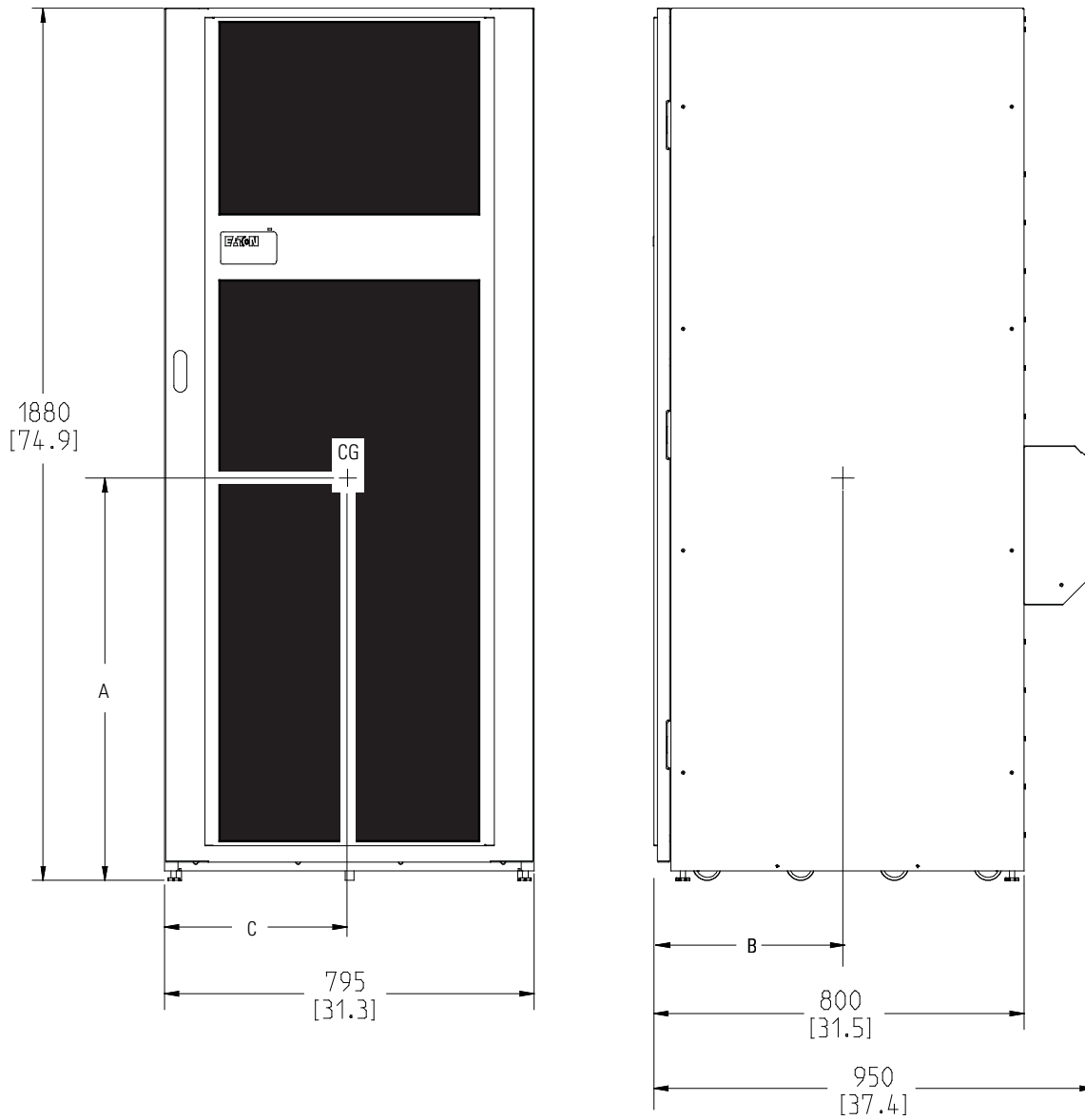

Dimensions are in millimeters [inches]

Center of Gravity			
	A	B	C
Single Transformer	515 (2.3)	416 (16.4)	397 (15.6)
Dual Transformer	800 (31.5)	416 (16.4)	397 (15.6)

Figure 3-6. 93E 60ITC Center of Gravity

3.2.2 ITC Power Wiring Preparation

Read and understand the following notes while planning and performing the installation:

 **WARNING**

As a result of the connected loads, high leakage current is possible. Connection to earth ground is required for safety and proper product operation. Do not check ITC operation by any action that includes removal of the earth (ground) connection with loads attached.

- Refer to national and local electrical codes for acceptable external wiring practices.
- Material and labor for external wiring requirements are to be provided by the customer.
- For external wiring, use 90°C copper wire. Wire sizes listed in Table 3-4 and Table 3-5 are for copper wiring only. If wire is run in an ambient temperature greater than 30°C (86°F), higher temperature wire and/or larger size wire may be necessary. Wire sizes are based on using the specified breakers.
- Wire ampacities are chosen from Table 310-16 of the National Electrical Code® (NEC®). Specification is for copper wire with a 90°C rating.
- Refer to NEC Article 250 and local codes for proper grounding practices.
- Per NEC Article 300-20(a), all three-phase conductors must be run in the same conduit. Neutral and ground must be run in the same conduit as the phase conductors.
- Phase rotation must be clockwise starting with phase A (rotation A,B,C).
- Conduit is to be sized to accommodate one neutral conductor the same size as the phase conductor and one ground conductor. If two neutral conductors or an oversized neutral conductor are to be installed, size the conduit to accommodate the extra wire or size.
- Refer to the appropriate Eaton 93E UPS installation and operation manual and listed in paragraph 1.6 for UPS cabinet conduit and terminal specifications and locations.
- Refer to the *Eaton 93E Integrated Accessory Cabinet-Distribution Installation Manual* listed in paragraph 1.6 for conduit and terminal locations and termination requirements.
- The term *line-up-and-match* refers to accessory cabinets that are physically located adjacent to the UPS. The term *standalone* refers to accessory cabinets that are located separate from the UPS.

For external power wiring requirements, including the minimum AWG size of external wiring, see Table 3-4 or Table 3-5. Wire sizes listed are for copper wiring only.

Table 3-4. External Power Wiring Requirements for the Eaton 93E 30ITC and 93E 60ITC – Single Transformer

Basic Unit Rating		Units	Rating 60 Hz	
		kVA	30	60
Input/Output Voltage		Volts	480/208	480/208
480 Vac Input to Input Transformer	A	Maximum Amps	43	85
(3) Phases, (1) Ground				
Minimum Conductor Size (Phase A, B, and C)		AWG or kcmil	#6	#2
Number per Phase		(each)	(1)	(1)
208 Vac Output from Input Transformer to UPS	B	Maximum Amps	96	192
(3) Phases, (1) Neutral, (1) Ground				
Minimum Conductor Size (Phase A, B, and C)		AWG or kcmil	1/0	250
Number per Phase		(each)	(1)	(1)
Minimum Conductor Size (Neutral)	—	AWG or kcmil	1/0	250
Number per Phase		(each)	(2)	(2)
Building, Load, and Inter-Cabinet Ground	—	AWG or kcmil	#6	#2
Minimum Conductor Size (Ground)		(each)	(1)	(1)
Number per Phase				

NOTE Callout letters **A** and **B** map to Figure 5-1

Table 3-5. External Power Wiring Requirements for the Eaton 93E 30ITC and 93E 60ITC – Dual Transformer

Basic Unit Rating		Units	Rating 60 Hz		
		kVA	30	60	
Input/Output Voltage		Volts	480/480	480/480	
480 Vac Input to Input Transformer (3) Phases, (1) Ground	A	Maximum Amps	43	85	
		Minimum Conductor Size (Phase A, B, and C) Number per Phase	AWG or kcmil (each)	#6 (1)	#2 (1)
208 Vac Output from Input Transformer to UPS (3) Phases, (1) Neutral, (1) Ground	B	Maximum Amps	96	192	
		Minimum Conductor Size (Phase A, B, and C) Number per Phase	AWG or kcmil (each)	1/0 (1)	250 (1)
		Minimum Conductor Size (Neutral) Number per Phase	—	AWG or kcmil (each)	1/0 (2)
208 Vac Input to Output Transformer from UPS (3) Phases, (1) Ground	C	Maximum Amps	83	167	
		Minimum Conductor Size (Phase A, B, and C) Number per Phase	AWG or kcmil (each)	1/0 (1)	250 (1)
480 Vac Output from Output Transformer to Critical Load (3) Phases, (1) Neutral, (1) Ground	D	Maximum Amps	37	74	
		Minimum Conductor Size (Phase A, B, and C) Number per Phase	AWG or kcmil (each)	#8 (1)	#4 (1)
		Minimum Conductor Size (Neutral) Number per Phase	—	AWG or kcmil (each)	#8 (2)
Building, Load, and Inter-Cabinet Ground	—	AWG or kcmil (each)	#6 (1)	#2 (1)	

NOTE Callout letters **A** through **D** map to Figure 5-1

The power wiring terminals are pressure terminations, UL and CSA rated at 90°C. See Table 3-6, Table 3-7, Table 3-8, or Table 3-9 for external power cable terminations.

Figure 4-10 and Figure 4-13 show the location of the ITC power cable terminals.

Table 3-6. External Input Power Cable Terminations for the Eaton 93E 30ITC – Single Transformer

Terminal Function	Terminal	Function	Size of Pressure Termination (AWG or kcmil)	Tightening Torque Nm (lb in)	Size Screw and Type
480 Vac Input to Input Transformer	XIB-2	Phase A	1 – #14-3/0	5.6 (50)	Slotted
	XIB-4	Phase B	1 – #14-3/0	5.6 (50)	Slotted
	XIB-6	Phase C	1 – #14-3/0	5.6 (50)	Slotted
208 Vac Output from Input Transformer to UPS	UIB-2	Phase A	1 – #14-3/0	5.6 (50)	Slotted
	UIB-4	Phase B	1 – #14-3/0	5.6 (50)	Slotted
	UIB-6	Phase C	1 – #14-3/0	5.6 (50)	Slotted
	T1-N	Neutral	2 – #6-250	22.6 (200)	1/4" Hex
Building, Load, and Inter-cabinet Ground	TBG	Ground	3 – #14-1/0	5.1 (45)	Slotted

Table 3-7. External Input Power Cable Terminations for the Eaton 93E 30ITC – Dual Transformer

Terminal Function	Terminal	Function	Size of Pressure Termination (AWG or kcmil)	Tightening Torque Nm (lb in)	Size Screw and Type
480 Vac Input to Input Transformer	XIB-2	Phase A	1 – #14-3/0	5.6 (50)	Slotted
	XIB-4	Phase B	1 – #14-3/0	5.6 (50)	Slotted
	XIB-6	Phase C	1 – #14-3/0	5.6 (50)	Slotted
208 Vac Output from Input Transformer to UPS	UIB-2	Phase A	1 – #14-3/0	5.6 (50)	Slotted
	UIB-4	Phase B	1 – #14-3/0	5.6 (50)	Slotted
	UIB-6	Phase C	1 – #14-3/0	5.6 (50)	Slotted
	T1-N	Neutral	2 – #6-250	22.6 (200)	1/4" Hex
208 Vac Input from UPS to Optional Output Transformer	UOB-2	Phase A	1 – #14-3/0	5.6 (50)	Slotted
	UOB-4	Phase B	1 – #14-3/0	5.6 (50)	Slotted
	UOB-6	Phase C	1 – #14-3/0	5.6 (50)	Slotted
480 Vac Output from Optional Output Transformer to Critical Load	XOB-2	Phase A	1 – #14-3/0	5.6 (50)	Slotted
	XOB-4	Phase B	1 – #14-3/0	5.6 (50)	Slotted
	XOB-6	Phase C	1 – #14-3/0	5.6 (50)	Slotted
	T2-N	Neutral	2 – #6-250	22.6 (200)	1/4" Hex
Building, Load, and Inter-cabinet Ground	TBG	Ground	3 – #14-1/0	5.1 (45)	Slotted

Table 3-8. External Input Power Cable Terminations for the Eaton 93E 60ITC – Single Transformer

Terminal Function	Terminal	Function	Size of Pressure Termination (AWG or kcmil)	Tightening Torque Nm (lb in)	Size Screw and Type
480 Vac Input to Input Transformer	XIB-2	Phase A	1 – #4-350	20.3 (180)	3/16" Hex
	XIB-4	Phase B	1 – #4-350	20.3 (180)	3/16" Hex
	XIB-6	Phase C	1 – #4-350	20.3 (180)	3/16" Hex
208 Vac Output from Input Transformer to UPS	UIB-2	Phase A	1 – #4-350	20.3 (180)	3/16" Hex
	UIB-4	Phase B	1 – #4-350	20.3 (180)	3/16" Hex
	UIB-6	Phase C	1 – #4-350	20.3 (180)	3/16" Hex
	T1-N	Neutral	2 – #6-250	22.6 (200)	1/4" Hex
Building, Load, and Inter-cabinet Ground	TBG	Ground	3 – #14-1/0	5.1 (45)	Slotted

Table 3-9. External Input Power Cable Terminations for the Eaton 93E 60ITC – Dual Transformer

Terminal Function	Terminal	Function	Size of Pressure Termination (AWG or kcmil)	Tightening Torque Nm (lb in)	Size Screw and Type
480 Vac Input to Input Transformer	XIB-2	Phase A	1 – #4-350	20.3 (180)	3/16" Hex
	XIB-4	Phase B	1 – #4-350	20.3 (180)	3/16" Hex
	XIB-6	Phase C	1 – #4-350	20.3 (180)	3/16" Hex
208 Vac Output from Input Transformer to UPS	UIB-2	Phase A	1 – #4-350	20.3 (180)	3/16" Hex
	UIB-4	Phase B	1 – #4-350	20.3 (180)	3/16" Hex
	UIB-6	Phase C	1 – #4-350	20.3 (180)	3/16" Hex
	T1-N	Neutral	2 – #6-250	22.6 (200)	1/4" Hex
208 Vac Input from UPS to Optional Output Transformer	UOB-2	Phase A	1 – #4-350	20.3 (180)	3/16" Hex
	UOB-4	Phase B	1 – #4-350	20.3 (180)	3/16" Hex
	UOB-6	Phase C	1 – #4-350	20.3 (180)	3/16" Hex
480 Vac Output from Optional Output Transformer to Critical Load	XOB-2	Phase A	1 – #4-350	20.3 (180)	3/16" Hex
	XOB-4	Phase B	1 – #4-350	20.3 (180)	3/16" Hex
	XOB-6	Phase C	1 – #4-350	20.3 (180)	3/16" Hex
	T2-N	Neutral	2 – #6-250	22.6 (200)	1/4" Hex
Building, Load, and Inter-cabinet Ground	TBG	Ground	3 – #14-1/0	5.1 (45)	Slotted

3.3 Inspecting and Unpacking the ITC

The cabinet is shipped bolted to a wooden pallet and covered with outer protective packaging material (see Figure 3-7).

 **NOTE** Startup and operational checks must be performed by an authorized Eaton Customer Service Engineer, or the warranty terms specified on page W-1 become void. This service is offered as part of the sales contract for the UPS. Contact an Eaton service representative in advance (usually a two-week notice is required) to reserve a preferred startup date.

 **WARNING**

The ITC is heavy (see Table 3-1). If unpacking and unloading instructions are not closely followed, the cabinet may tip and cause serious injury.

1. Carefully inspect the outer packaging for evidence of damage during transit.
-

 **CAUTION**

Do not install a damaged cabinet. Report any damage to the carrier and contact an Eaton service representative immediately.

 **NOTE** For the following step, verify that the forklift or pallet jack is rated to handle the weight of the cabinet (see Table 3-1 for cabinet weight).

2. Use a forklift or pallet jack to move the packaged cabinet to the installation site, or as close as possible, before unpacking. If possible, move the cabinet using the pallet. Insert the forklift or pallet jack forks between the supports on the bottom of the pallet (see Figure 3-3 or Figure 3-6) for the ITC cabinet center of gravity measurements).
-

 **CAUTION**

Do not tilt the ITC cabinet more than 10° from vertical or the cabinets may tip over.

3. Set the pallet on a firm, level surface, allowing a minimum clearance of 3m (10 ft) on each side for removing the cabinet from the pallet.
 4. Remove the protective packaging material from the cabinet and recycle in a responsible manner. Retain the parts kit box packed at the top of the cabinet.
 5. Inspect the contents for any evidence of physical damage, and compare each item with the Bill of Lading. If damage has occurred or shortages are evident, contact an Eaton service representative immediately to determine the extent of the damage and its impact on further installation.
-

 **NOTE** While waiting for installation, protect the unpacked cabinet from moisture, dust, and other harmful contaminants. Failure to store and protect the ITC properly may void your warranty.

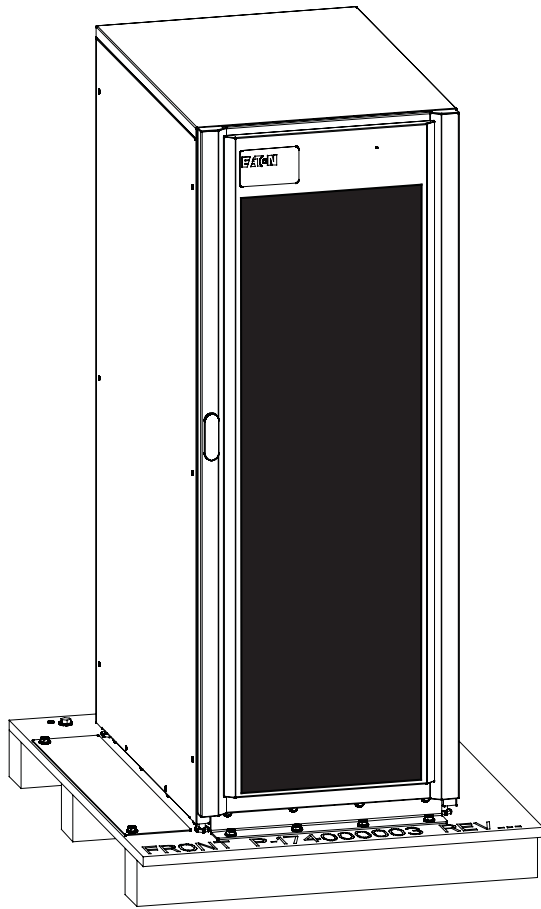

93E 30ITC

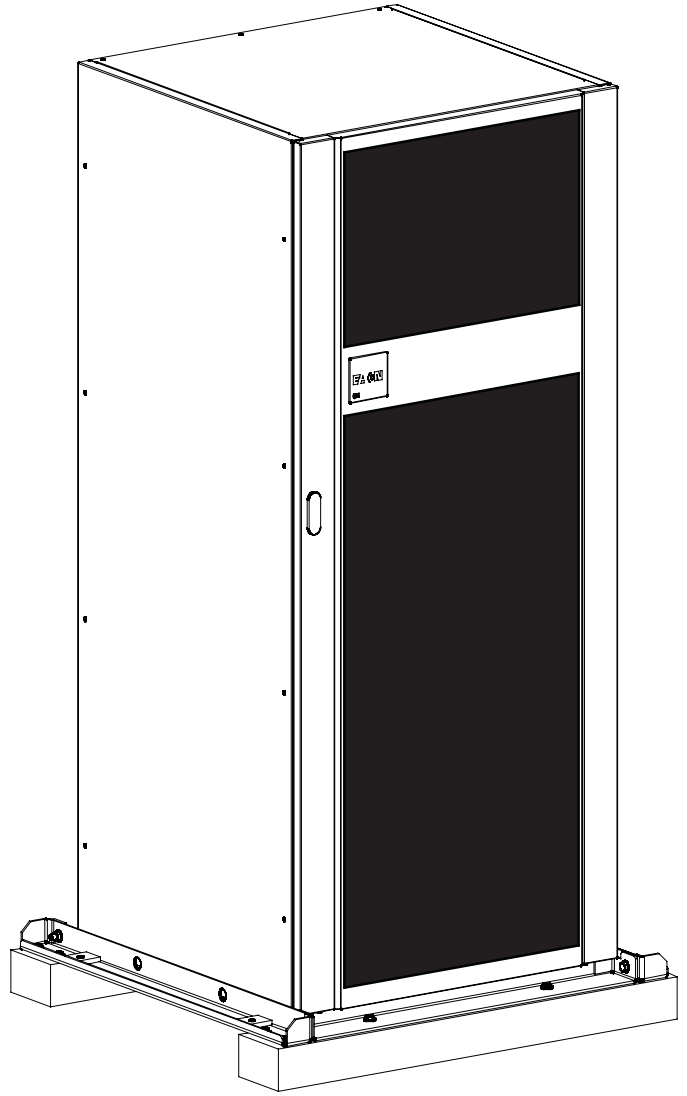

93E 60ITC

Figure 3-7. Eaton 93E 30ITC and Eaton 93E 60ITC as Shipped on Pallet

3.4 Transformer Breaker Location

Figure 3-8 shows the location of the transformer breakers in the 93E 30ITC and the 93E 60ITC.

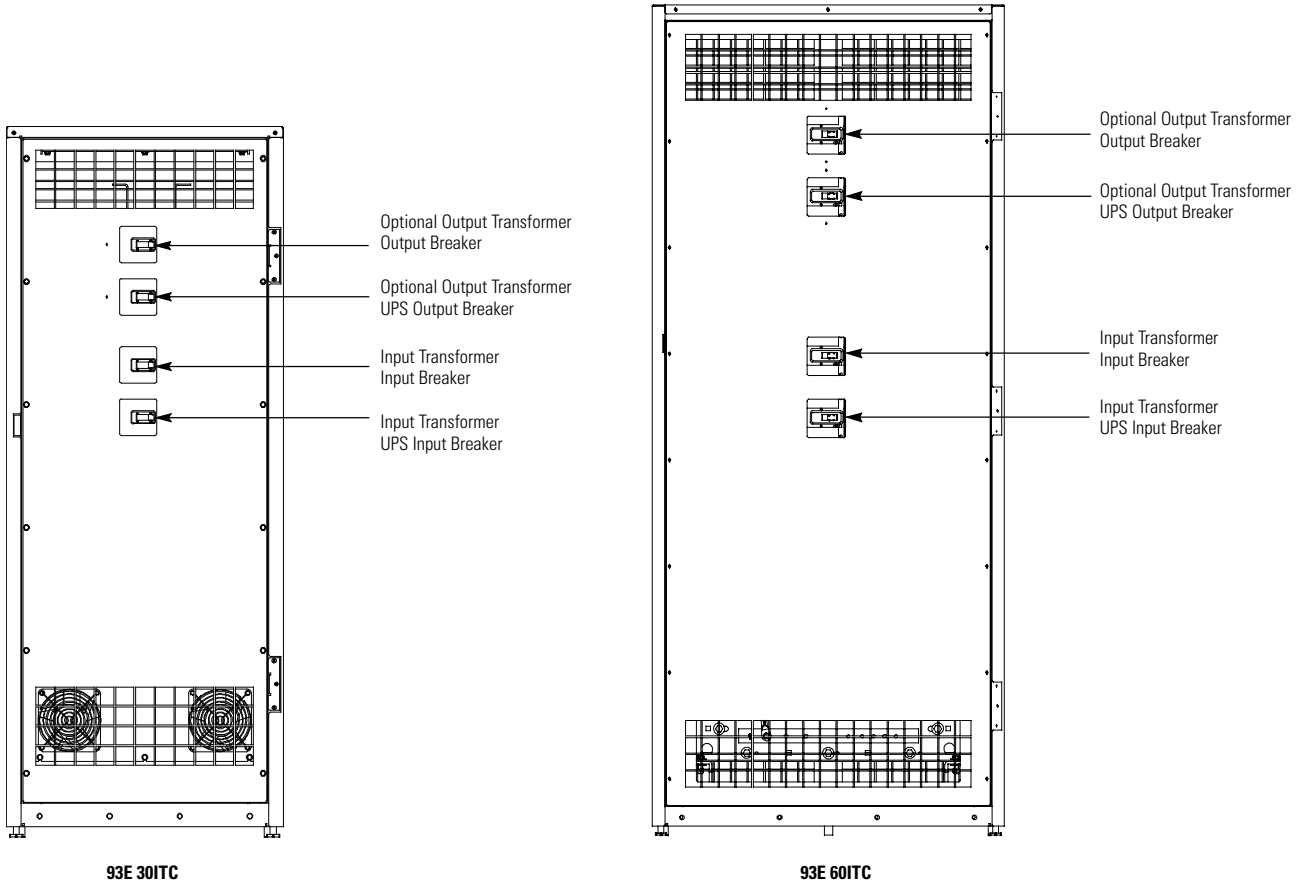

Figure 3-8. Eaton 93E 30ITC and Eaton 93E 60ITC Transformer Breaker Locations – Front Views with Doors Removed

Chapter 4 Installation

4.1 Preliminary Installation Information

 WARNING

Installation should be performed only by qualified personnel.

Refer to the following when installing the Integrated Transformer Cabinet (ITC):

- Chapter 3 for cabinet dimensions, equipment weight, wiring and terminal data, and installation notes.
- Do not tilt the cabinets more than 10° during installation.

4.2 Unloading the ITC from the Pallet

The ITC is bolted to a wooden pallet supported by wood skids.

 WARNING

The ITC is heavy (see Table 3-1). If unpacking and unloading instructions are not closely followed, the cabinet may tip and cause serious injury.

 CAUTION

- Do not tilt cabinet more than 10° from vertical.
 - Lift the cabinets only with a forklift or pallet jack or damage may occur.
 - Verify that a minimum of 10 feet behind the ITC is unobstructed for unloading.
 - The unloading floor must be smooth, with no cracks or large seams to prevent a smooth roll-off of the cabinet.
-

NOTE 1 The ITC uses inline wheels, not swivel casters. When moving the ITC, move the cabinet in straight lines as much as possible, minimizing turns.



NOTE 2 For the following steps, verify that the forklift or pallet jack is rated to handle the weight of the cabinet (see Table 3-1).

4.2.1 Unloading the 30ITC

To remove the pallet:

1. If not already completed, use a forklift or pallet jack to move the ITC to the installation area, or as close as possible, before unloading from the pallet. Insert the forklift or pallet jack forks between the supports on the bottom of the pallet (see Figure 3-3 for the ITC cabinet center of gravity measurements).
2. Open the front door by lifting the latch from the bottom and turning to the right (counterclockwise) then swing the door open.
3. If the leveling feet are not fully retracted, turn all four leveling feet until they are retracted into the cabinet.
4. Remove four bolts securing the front shipping bracket to the cabinet and four bolts securing the bracket to the pallet (see Figure 4-1). Remove the front shipping bracket. If installing the cabinet permanently, retain the shipping bracket and securing hardware for later use.

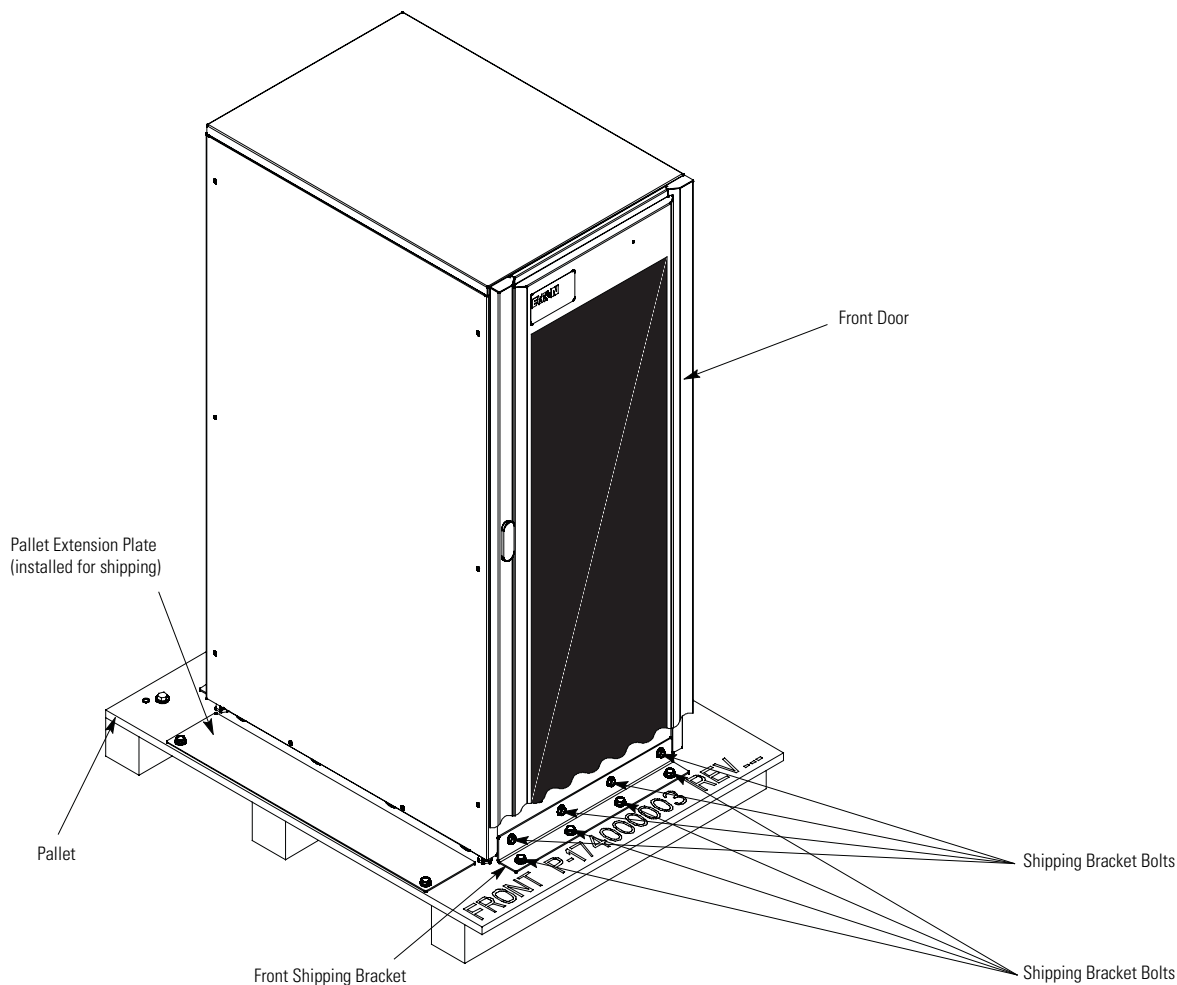

Figure 4-1. Removing the Front Shipping Bracket – 93E 30ITC

5. Remove four bolts securing the rear shipping bracket to the cabinet and four bolts securing the bracket to the pallet (see Figure 4-2). Remove the rear shipping bracket. If installing the cabinet permanently, retain the shipping bracket and securing hardware for later use.
6. Close the door and secure the latch before rolling the cabinet from the pallet.
7. Remove three bolts securing the removable skid (see Figure 4-2).
8. Remove two bolts securing the pallet extension plate to the pallet and remove the plate (see Figure 4-1).
9. Install the pallet extension plate onto the rear of the pallet using the retained bolts (see Figure 4-3). Use the mounting holes provided in the pallet (see Figure 4-2).
10. Use a forklift or pallet jack between the supports on the bottom of the pallet to lift the pallet by approximately 3 mm (1/8") and remove the skid (see Figure 4-2).

NOTE 1 In Step 11 the pallet tilts and acts as a ramp when the cabinet is rolled beyond the center of the pallet.



NOTE 2 The pallet extension may bend when the pallet is tilted, but will continue to provide a smooth transition to the floor.

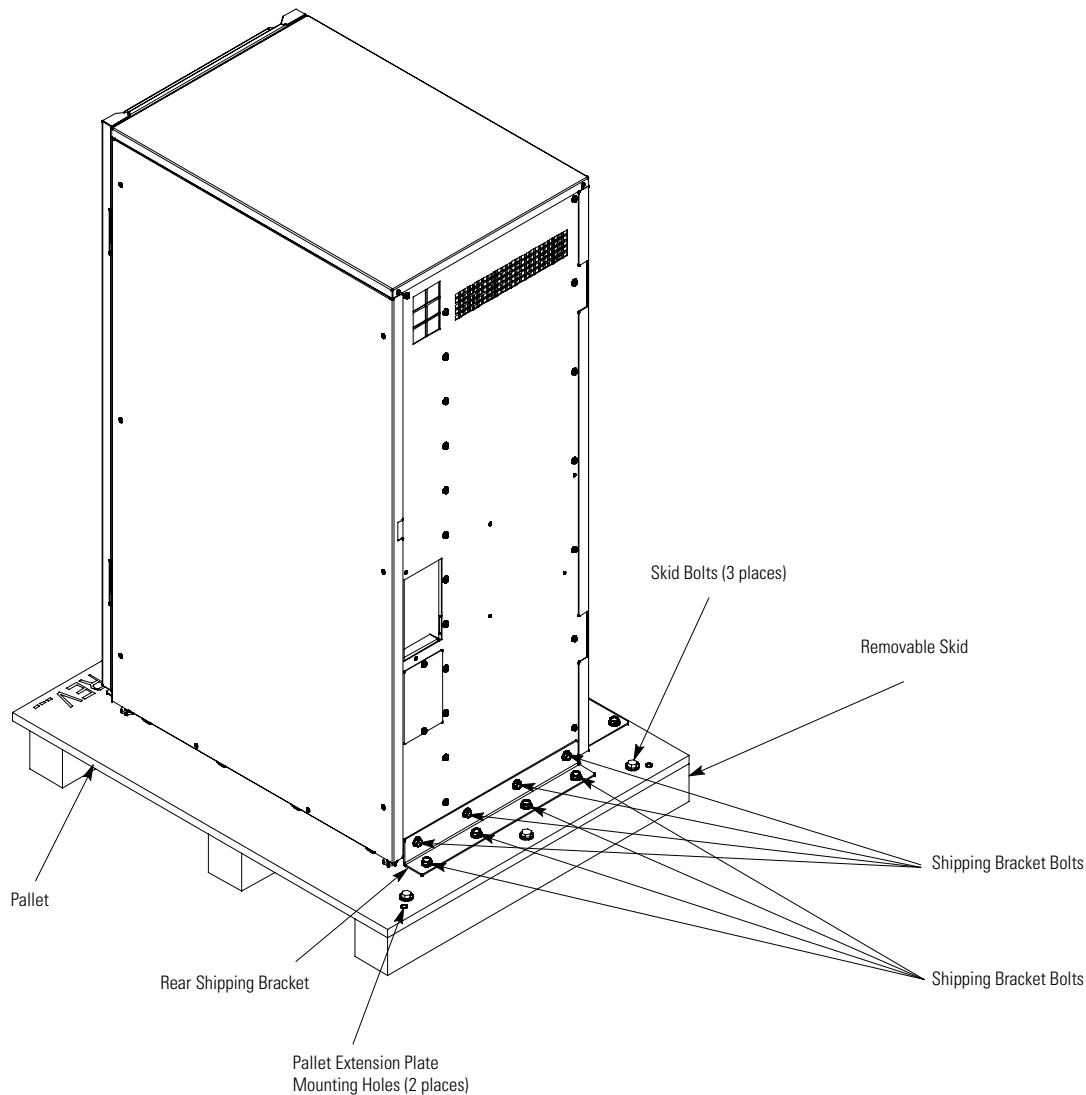

Figure 4-2. Removing the Rear Shipping Bracket – 93E 30ITC

⚠ WARNING

Do not stand directly in front of or behind the pallet when unloading the cabinet. If unloading instructions are not closely followed, the cabinet may cause serious injury.

11. Slowly roll the cabinet toward the rear of the pallet. When the pallet tilts, continue rolling the cabinet down the pallet extension plate until the cabinet is clear of the pallet.
12. Roll the ITC to the final installation location to the left of the UPS cabinet. Verify that the doors are flush with each other.
13. If installing the cabinet permanently, retain the shipping brackets and hardware; otherwise, recycle the pallet and shipping brackets in a responsible manner.

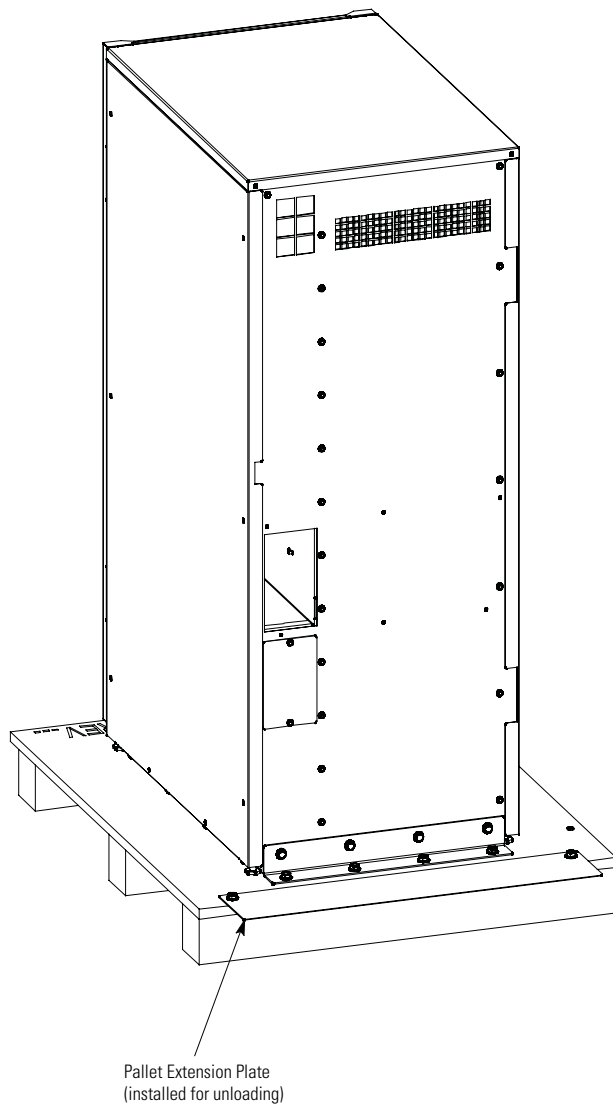

Figure 4-3. Installing the Pallet Extension Plate – 93E 30ITC



NOTE

Use leveling feet only to lock the cabinet in place. Using the leveling feet to raise the cabinet may result in serious injury to personnel or damage to the cabinet.

14. Secure the ITC in position by lowering the leveling feet until the cabinet is locked in place.
15. If installing the ITC permanently, continue to Step 16; otherwise, skip to Step 18.
16. Using the retained hardware (removed in Steps 4 and 5), reinstall the shipping brackets to the front and rear of the ITC with the angle facing outward (see Figure 4-1 and Figure 4-2).
17. Secure the cabinet to the floor with customer-supplied hardware.
18. If installing a second ITC for dual-feed, repeat Steps 1 through 17; otherwise, continue to Step 19. Install the second ITC on the left side of the first ITC.
19. Proceed to paragraph 4.3.

4.2.2 Unloading the 60ITC

The ITC is bolted to a pallet consisting of four metal angle supports secured to two wood supports.

To remove the pallet:

1. If not already accomplished, use a forklift or pallet jack to move the ITC to the installation area, or as close as possible, before unloading from the pallet. Insert the forklift or pallet jack forks between the supports on the bottom of the pallet (see Figure 3-6 for the ITC cabinet center of gravity measurements).
2. Open the front door (see Figure 4-4) by lifting the latch from the bottom and turning to the right (counterclockwise) and swing the door open.
3. Locate the four 1/2" jacking bolts from the parts kit and install them in the threaded holes in the front and rear supports as shown in Figure 4-4. Place a floor protector from the parts kit underneath each jacking bolt, and screw the bolts down against them.

The floor protectors protect the floor from being marred by the jacking bolts.

4. Loosen, but do not remove, the skid mounting bolts holding the pallet skids to the front and rear supports (see Figure 4-4).

WARNING

RISK OF INSTABILITY. Turning the jacking bolts unevenly may cause the cabinet to become unbalanced. To prevent tipping the cabinet, raise and lower the jacking bolts evenly.

CAUTION

CABINET MAY TIP. Raise the EBC no more than 3 mm (1/8") above the floor (just enough to allow the removal of the pallet skids).

5. Turn each jacking bolt consecutively, two full turns, until the pallet skids clear the floor by approximately 3 mm (1/8").
6. Remove the hardware loosened in Step 4. Pull the two pallet skids out from under the front and rear supports. Recycle the pallet skids and hardware in a responsible manner.

CAUTION

CABINET MAY FALL. Do not loosen the hardware attaching the front supports to the cabinet base. The cabinet must be lowered by the jacking bolts before the supports can be removed.

7. Carefully and evenly **lower the cabinet by turning each jacking bolt consecutively two full turns (maximum)** until the casters contact the floor and the cabinet is no longer supported by the jacking bolts.
8. After the ITC is resting on the floor, remove the jacking bolts and floor protectors. Recycle them in a responsible manner.
9. Remove the cabinet mounting bolts holding the front and rear supports to the cabinet base (see Figure 4-4).
10. If installing the cabinet permanently, retain the cabinet mounting bolts; otherwise, recycle the bolts along with the support brackets in a responsible manner.
11. Close the door and secure the latch.
12. If the leveling feet are not retracted, turn all four leveling feet until they are retracted as far into the cabinet as possible.

13. Roll the ITC to the final installation location on the right side of the UPS cabinet making sure the doors are flush with each other.

**NOTE**

Use leveling feet only to lock the cabinet in place. Using the leveling feet to raise the cabinet may result in serious injury to personnel or damage to the cabinet.

14. Secure the ITC in position by lowering the leveling feet until the cabinet is locked in place.
15. If permanently mounting the ITC, proceed to Step 16; otherwise, proceed to Step 19.
16. Locate the two floor mounting brackets from the parts kit.
17. Using the retained cabinet mounting bolts, install the floor mounting brackets to the front and rear of the ITC with the angle facing outward.
18. Secure the cabinet to the floor with customer-supplied hardware.
19. If installing a second ITC for dual-feed, repeat Steps 1 through 19; otherwise, proceed to Step 20. Install the second ITC on the left side of the first ITC.
20. Proceed to paragraph 4.3.

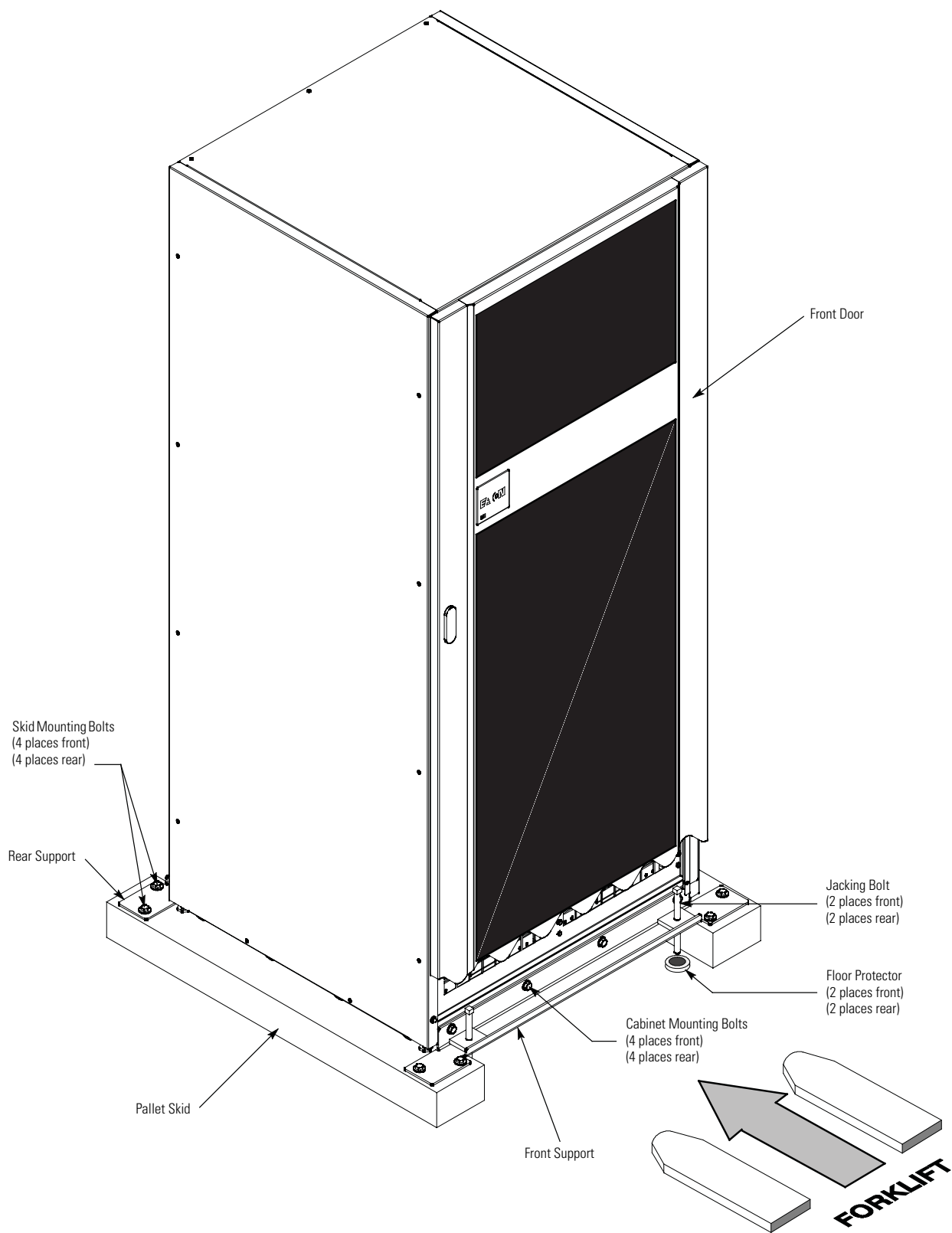

Figure 4-4. Removing the Pallet Skids and Supports – 93E 60ITC

4.3 Installing the Power Terminal Cover Base



NOTE Wiring can be installed using conduit between cabinets or by routing wiring through the power terminal cover base wiring channels.

To install the power terminal cover base:

1. Locate the terminal cover base (see Figure 4-5) from the parts kit.
2. If installing wiring using conduit, continue to Step 3; otherwise, skip to Step 4.
3. Punch or drill holes in the bottom of the power terminal cover base (see Figure 4-5 and Figure 4-6) for the transformer AC input and output conduits.
4. Using the hardware provided, install the terminal cover base to the back panel of the ITC using the existing cabinet screw holes (see Figure 4-6).
5. Continue to paragraph 4.4.

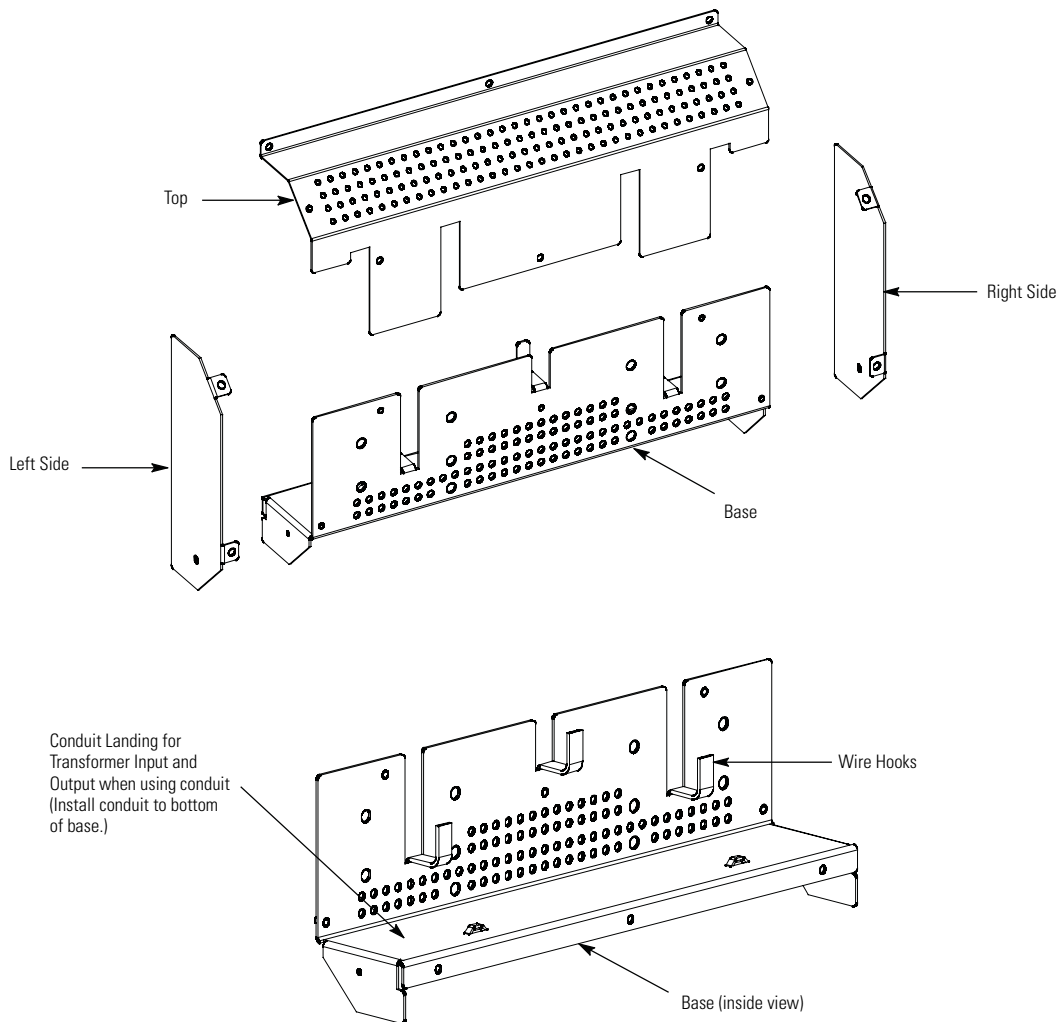

NOTE Do not install the Power Terminal Cover Left and/or Right Side covers if wiring adjacent cabinets using the power terminal base wiring channel.

Figure 4-5. ITC Power Terminal Cover Parts

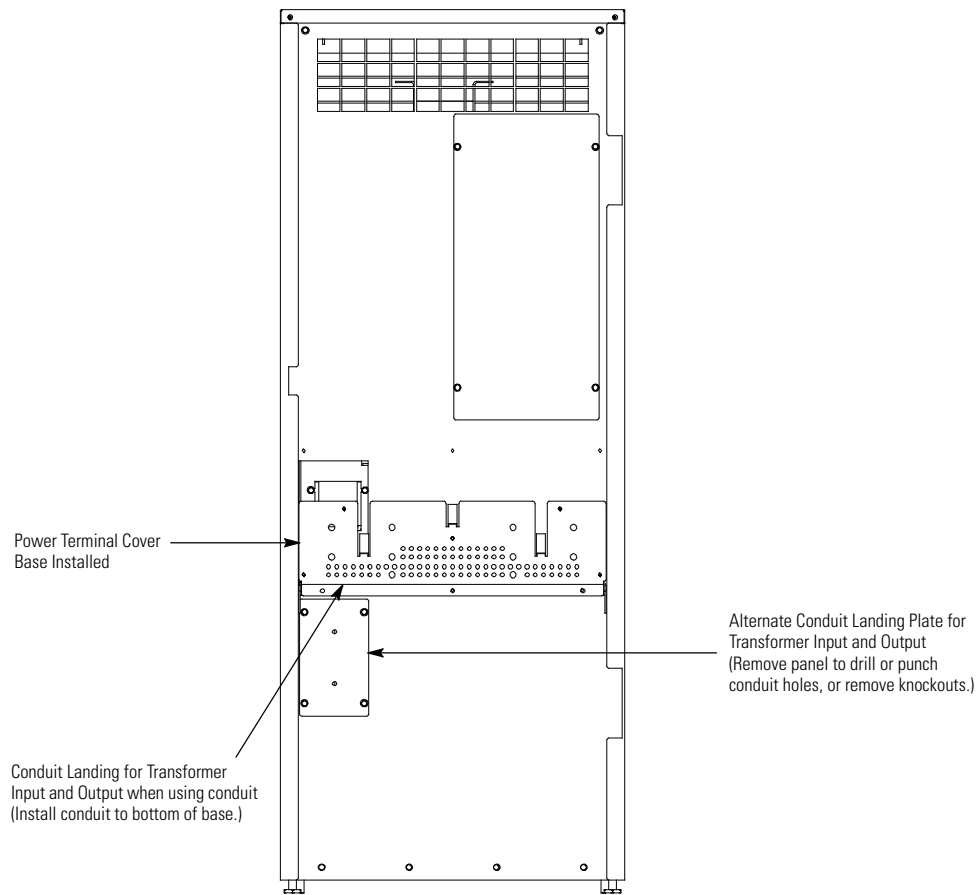

Figure 4-6. Eaton 93E 30ITC Power Terminal Cover Base Installation and Conduit Wire Entry Location

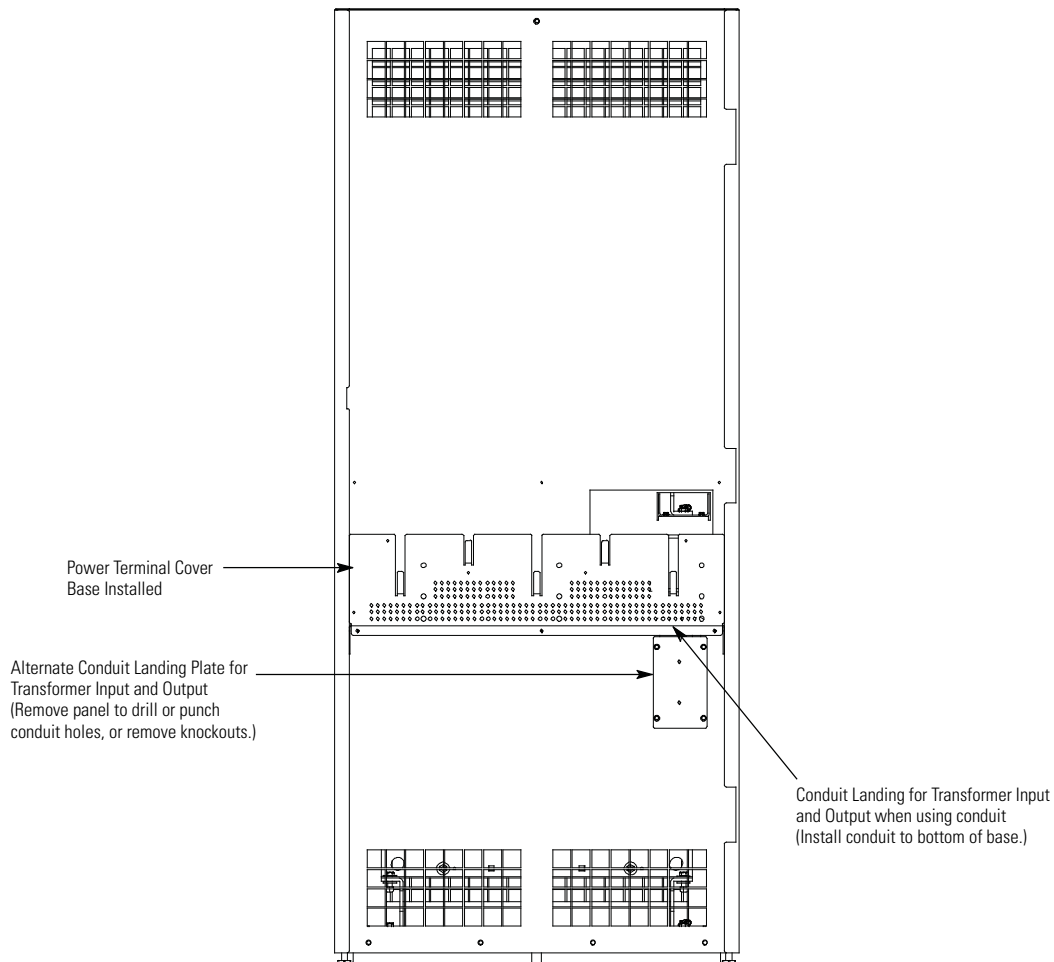

Figure 4-7. Eaton 93E 60ITC Power Terminal Cover Base Installation and Conduit Wire Entry Location

4.4 Installing ITC External Power Wiring

NOTE 1 Wiring can be installed using conduit between cabinets or by routing wiring through the power terminal cover base wiring channels.



NOTE 2 Remove the ITC conduit landing plates to drill or punch conduit holes, or remove knockouts the knockouts in the conduit plate (see Figure 4-6 or Figure 4-7).

4.4.1 Single-Feed UPS with Input Transformer

To install wiring to connections:

1. If not already open, open the front door by lifting the latch from the bottom and turning to the right (counterclockwise) and swing the door open (see Figure 4-1 or Figure 4-4).
2. Remove the screws securing the internal safety shield panel and remove the panel to gain access to the input and output breaker terminals. Retain the hardware for later use.
3. Install conduit between the utility source and the ITC.

4. Route the AC utility source input wiring (phase A, B, and C, and Ground) through the conduit and the wire tray (Figure 4-8 or Figure 4-9) on the back of the ITC to the ITC AC input to transformer terminals. See Figure 4-10 or Figure 4-13 for ITC terminal locations. See paragraph 3.2.2, Table 3-4, and Table 3-5 for ITC wiring and termination requirements.
5. Connect phase A, B, C, and ground ITC input power wiring from the utility source to the ITC AC input to transformer terminals and ground terminals. See paragraph 3.2.2 for wiring and termination requirements.
6. If installing wiring using conduit, continue to Step 7; if using the power terminal cover base channels, skip to Step 15.
7. Punch or drill holes in the bottom of the power terminal cover base on the UPS cabinet for the UPS rectifier input conduit. Refer to the applicable Eaton 93E UPS Installation and Operation manual listed in paragraph 1.6 for UPS cabinet conduit landing location.
8. Install conduit between the UPS cabinet and the ITC.
9. Route the UPS rectifier input wiring (phase A, B, and C, Neutral and Ground) from the ITC through the wire tray and the conduit to the UPS terminal block on the back of the UPS. See Figure 4-10 or Figure 4-13 for ITC terminal locations. See paragraph 3.2.2, Table 3-4, and Table 3-5 for ITC wiring and termination requirements. Refer to the applicable Eaton 93E UPS Installation and Operation manual listed in paragraph 1.6 for their respective terminal locations and termination requirements.
10. Connect phase A, B, C, Neutral, and Ground rectifier input power wiring from the ITC to the UPS rectifier input, neutral, and ground terminals. See paragraph 3.2.2 for wiring and termination requirements.
11. Connect phase A, B, C, Neutral, and Ground ITC output power wiring to the ITC AC output to UPS, neutral, and ground terminals. See paragraph 3.2.2 for wiring and termination requirements.
12. Install the power terminal cover top using the provided hardware (see Figure 4-17).
13. Install the power terminal cover right and left sides using the provided hardware (see Figure 4-17).
14. Skip to Step 22.
15. Route the UPS rectifier input wiring (phase A, B, and C, Neutral and Ground) from the ITC through the wire tray and the power terminal cover base wiring channels (see Figure 4-16) on the back of the ITC to the UPS terminal block on the back of the UPS. See Figure 4-10 or Figure 4-13 for ITC terminal locations. See paragraph 3.2.2, Table 3-4, and Table 3-5 for ITC wiring and termination requirements. Refer to the applicable Eaton 93E UPS Installation and Operation manual listed in paragraph 1.6 for their respective terminal locations and termination requirements.
16. Connect phase A, B, C, Neutral, and Ground rectifier input power wiring from the ITC to the UPS rectifier input, neutral, and ground terminals. See paragraph 3.2.2 for wiring and termination requirements.
17. Connect phase A, B, C, Neutral, and Ground ITC output power wiring to the ITC AC output to UPS, neutral, and ground terminals. See paragraph 3.2.2 for wiring and termination requirements.
18. Secure the power cables to the power terminal cover base using wire ties after all electrical connections have been completed.
19. Install the power terminal cover tops using the provided hardware (see Figure 4-18).
20. Install the ITC left side power terminal cover and the UPS right side power terminal cover using the provided hardware (see Figure 4-18).
21. Install the splice cover using the provided hardware (see Figure 4-18).
22. Reinstall the internal safety shield panel removed in Step 2.
23. Close the outside door and secure the latch.
24. After the ITC is installed and wired, return to the applicable Eaton 93E UPS Installation and Operation manual listed in paragraph 1.6 to complete the UPS wiring.

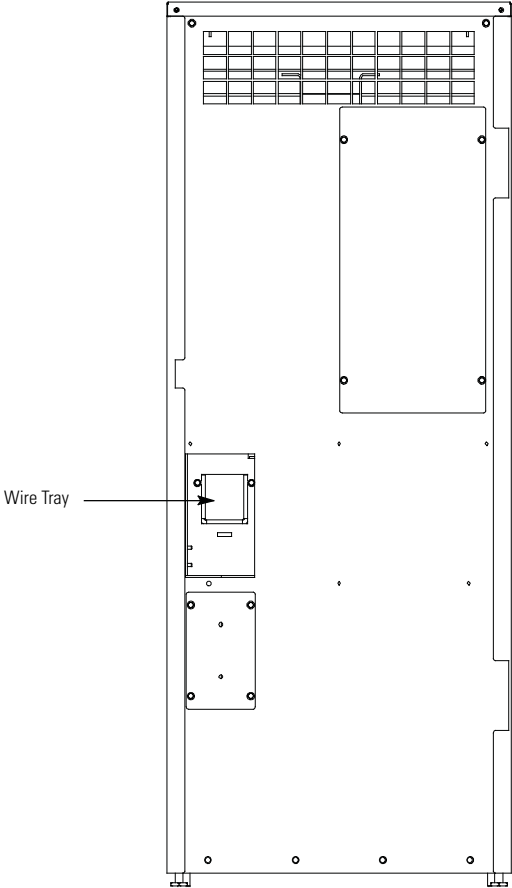

Figure 4-8. Wire Tray Location – 93E 30ITC

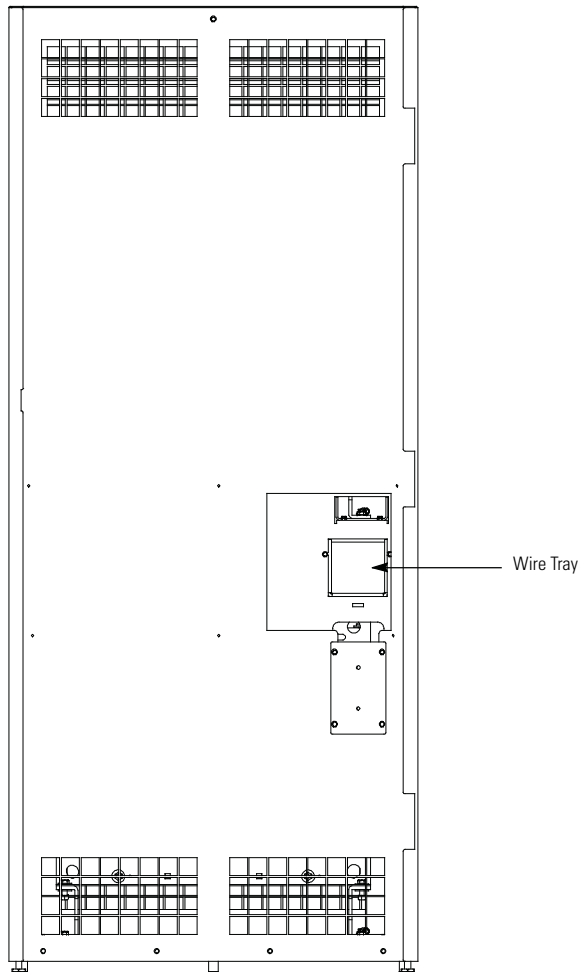

Figure 4-9. Wire Tray Location – 93E 60ITC

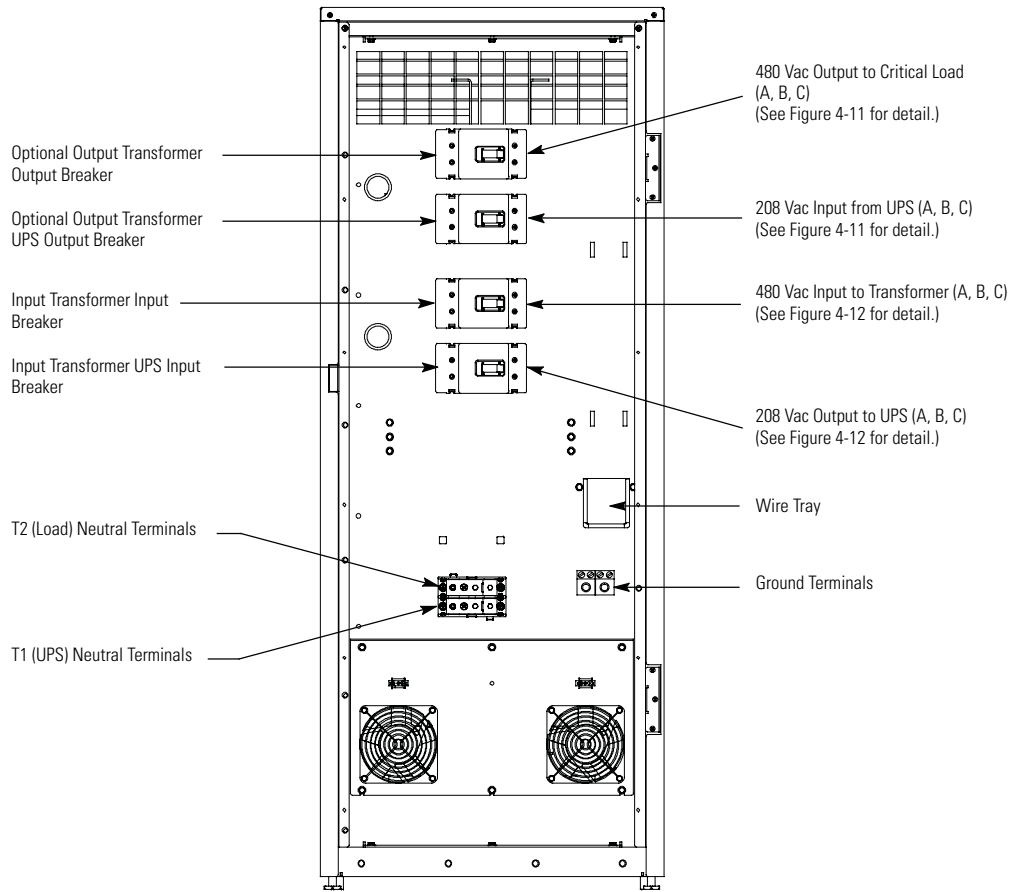

Figure 4-10. Input and Output Power Terminal Locations – 93E 30ITC

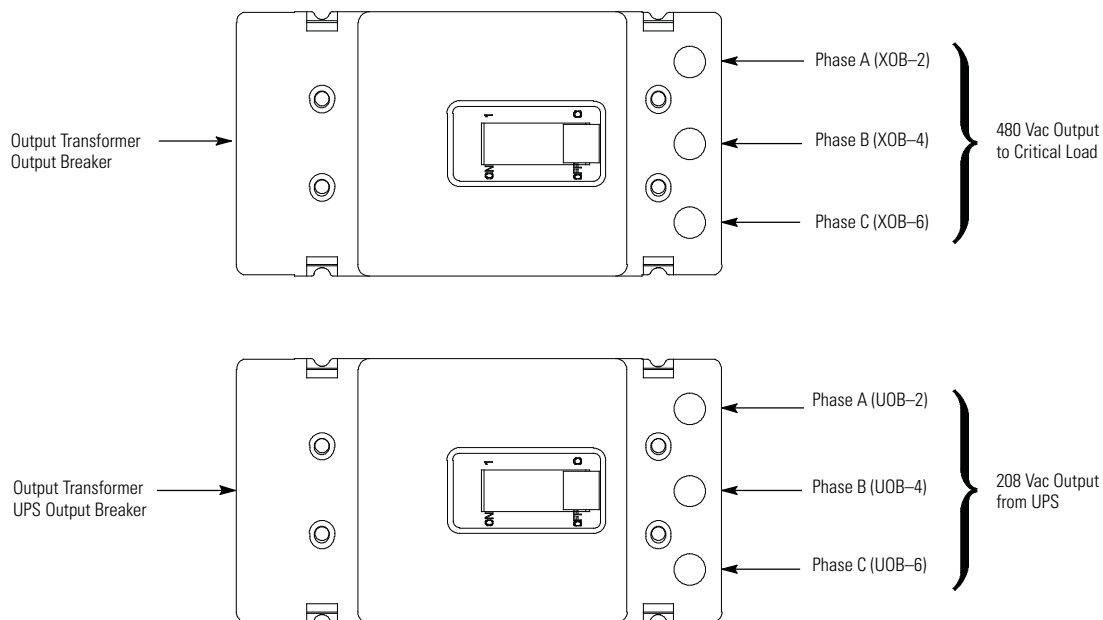

Figure 4-11. Output Transformer Breaker Terminal Detail – 93E 30ITC

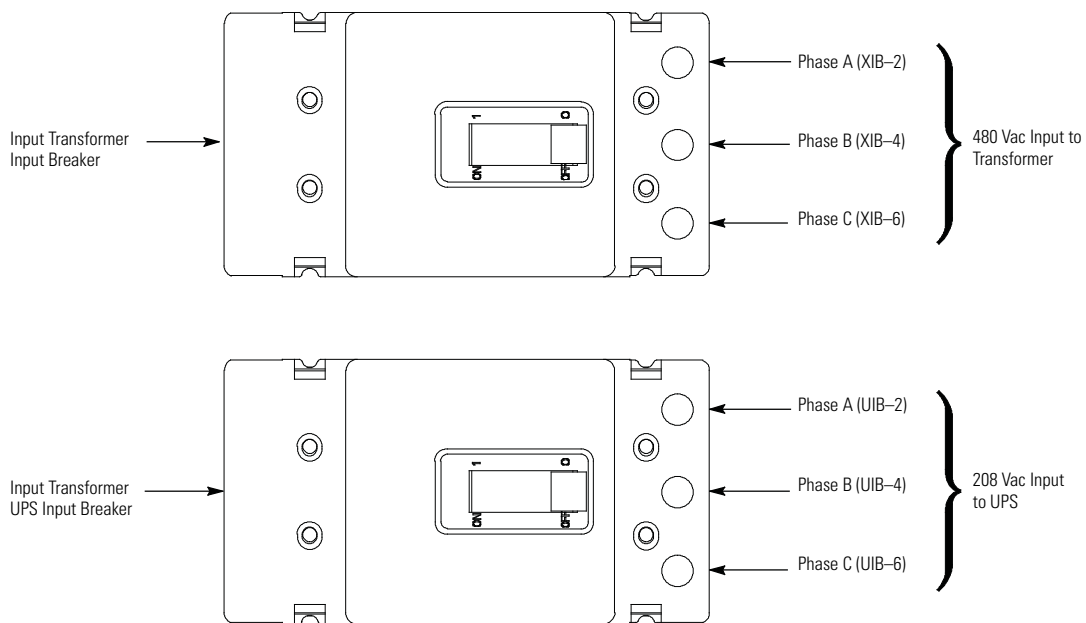

Figure 4-12. Input Transformer Breaker Terminal Detail – 93E 30ITC

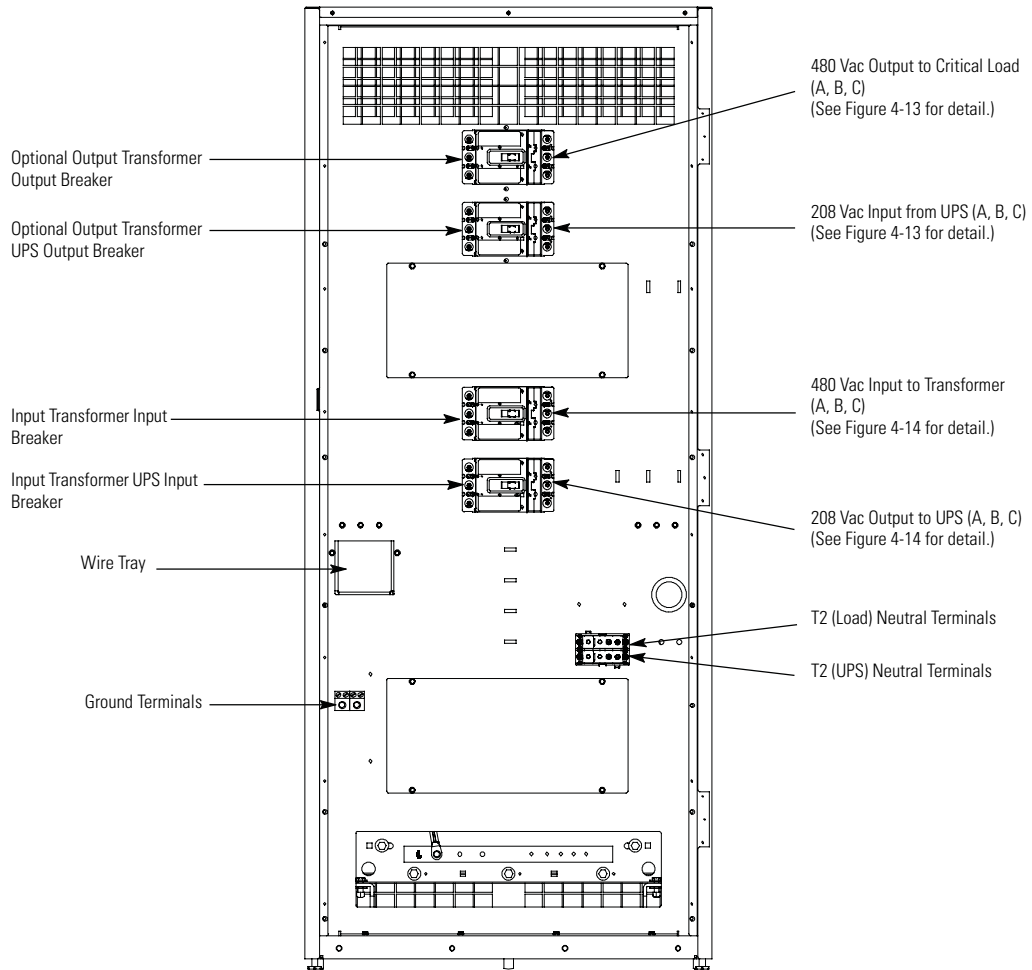

Figure 4-13. Input and Output Power Terminal Locations – 93E 60ITC

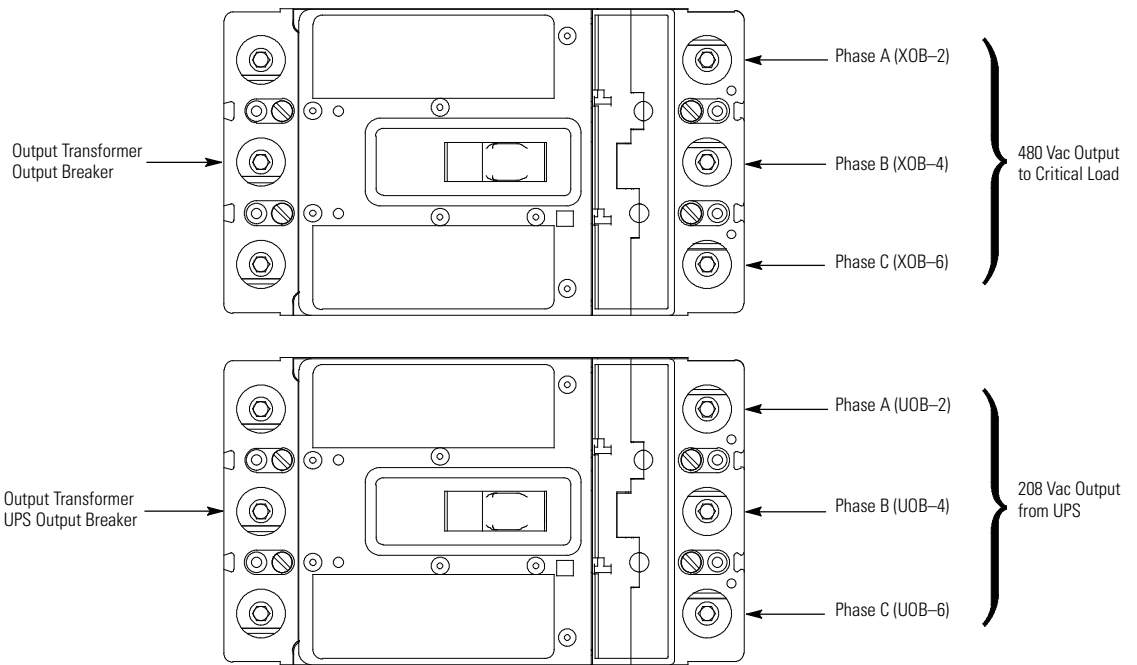

Figure 4-14. Output Transformer Breaker Terminal Detail – 93E 60ITC

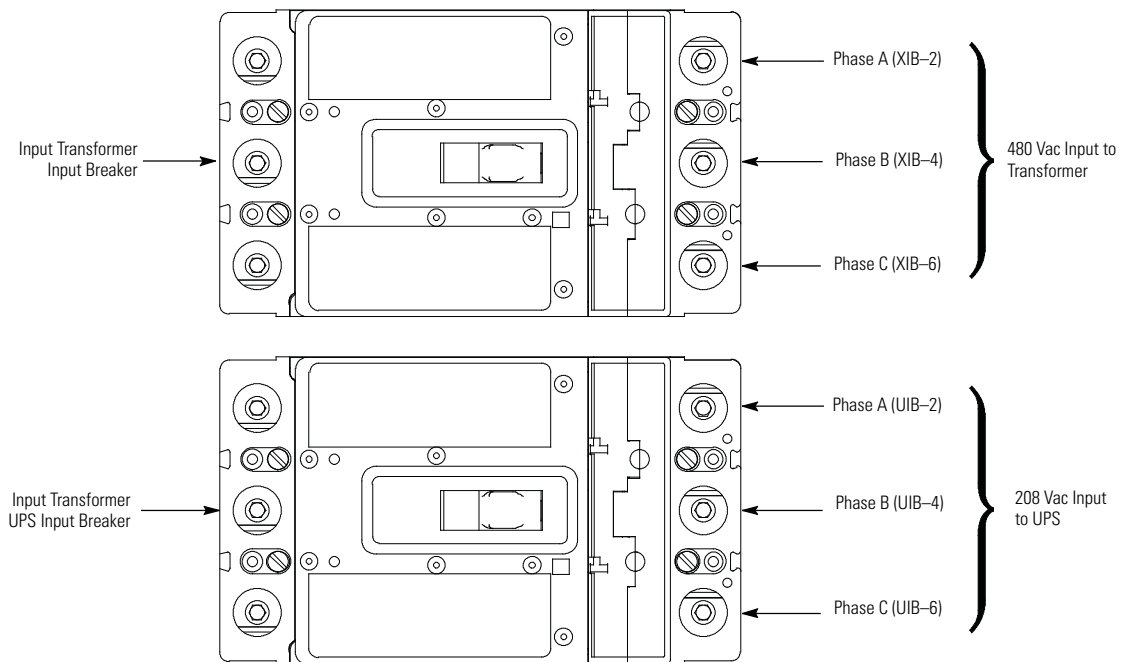
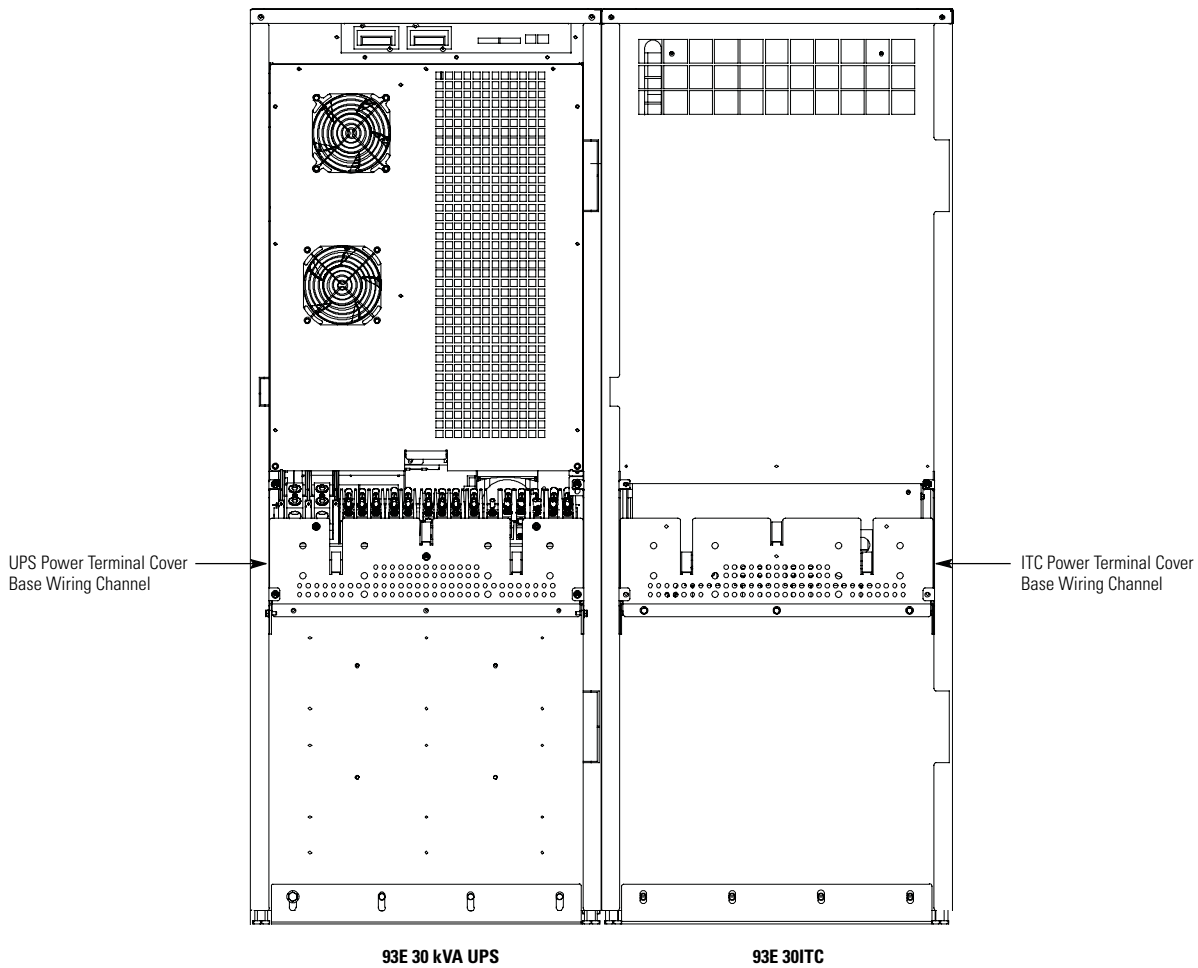

Figure 4-15. Input Transformer Breaker Terminal Detail – 93E 60ITC



NOTE 1 The 93E 30ITC and 93E 30 kVA UPS are shown. The 93E 60ITC and 93E 60 kVA UPS installation is the same.

NOTE 2 The UPS and ITC are shown adjacent, but other installed accessory cabinets may be adjacent in large systems with multiple cabinets. However, the power terminal base wiring channels are the same.

Figure 4-16. ITC and UPS Power Terminal Cover Base Wiring Channel

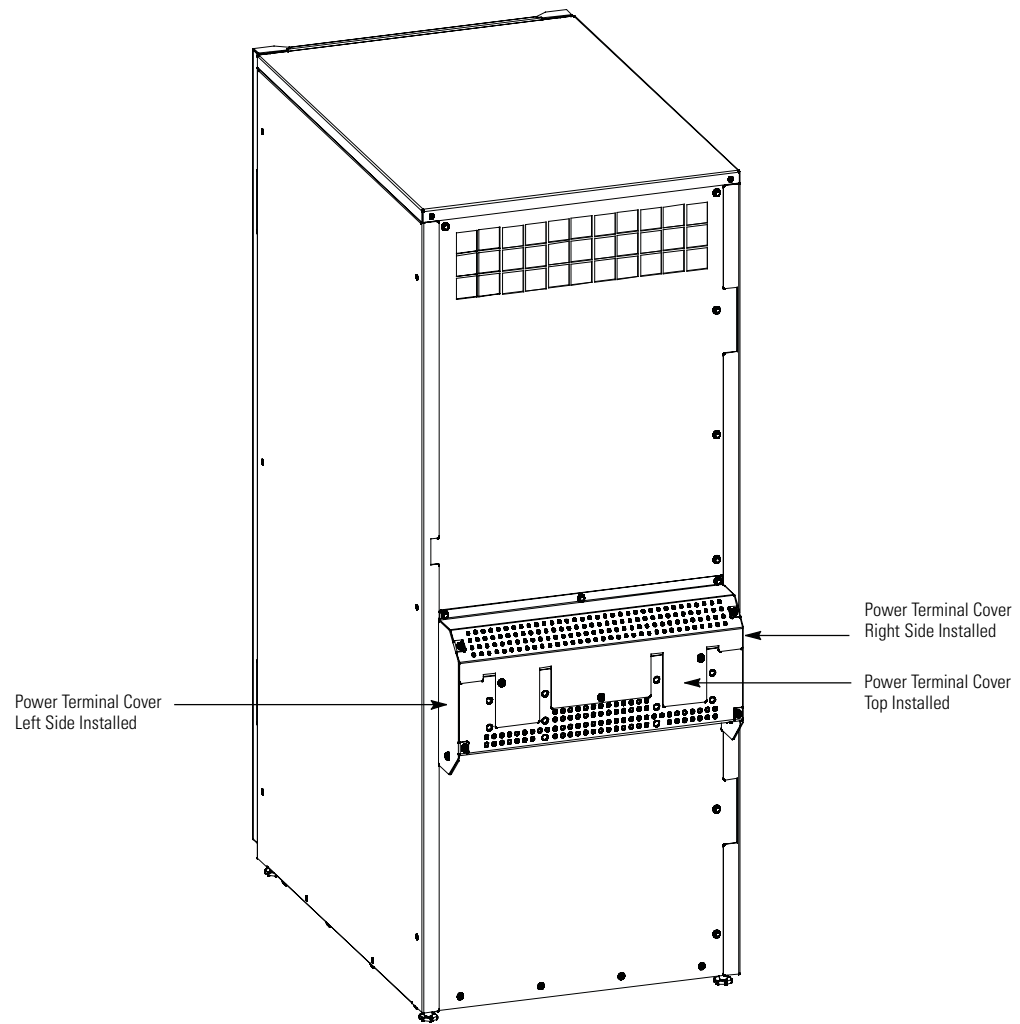

NOTE 1 The 93E 30ITC is shown. The 93E 60ITC installation is the same.

NOTE 2 Do not install the Power Terminal Cover Left and/or Right Side covers if wiring adjacent cabinets using the power terminal base wiring channel.

Figure 4-17. ITC Power Terminal Cover Install

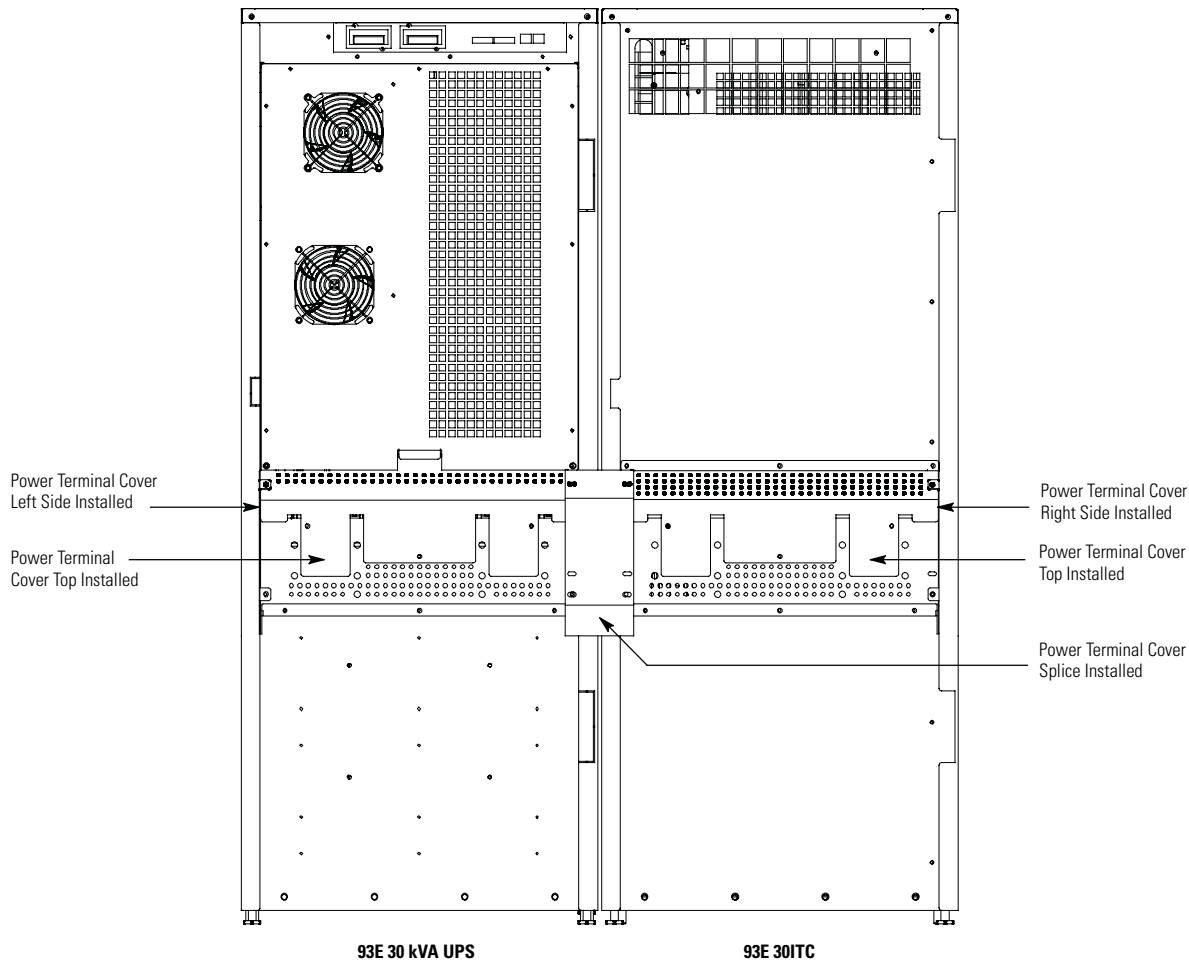

- NOTE 1** The 93E 30ITC and 93E 30 kVA UPS are shown. The 93E 60ITC and 93E 60 kVA UPS installation is the same.
- NOTE 2** The UPS and ITC are shown adjacent, but other installed accessory cabinets may be adjacent in large systems with multiple cabinets. However, the cover splice installation is the same.
- NOTE 3** Do not install the Power Terminal Cover Left and/or Right Side covers if wiring adjacent cabinets using the power terminal base wiring channel.

Figure 4-18. ITC Power Terminal Cover Splice Installation

4.4.2 Single-Feed UPS with Input and Output Transformers

To install wiring to connections:

1. If not already open, open the front door by lifting the latch from the bottom and turning to the right (counterclockwise) and swing the door open (see Figure 4-1 or Figure 4-4).
2. Remove the screws securing the internal safety shield panel and remove the panel to gain access to the input and output breaker terminals. Retain the hardware for later use.
3. Install conduit between the utility source and the ITC.

4. Route the AC utility source input wiring (phase A, B, and C, and Ground) through the conduit and the wire tray (Figure 4-8 or Figure 4-9) on the back of the ITC to the ITC AC input to transformer terminals. See Figure 4-10 or Figure 4-13 for ITC terminal locations. See paragraph 3.2.2, Table 3-4, and Table 3-5 for ITC wiring and termination requirements.
5. Connect phase A, B, C, and ground ITC input power wiring from the utility source to the ITC AC input to transformer terminals and ground terminals. See paragraph 3.2.2 for wiring and termination requirements.
6. If installing wiring using conduit, continue to Step 7; if using the power terminal cover base channels, skip to Step 21.
7. Punch or drill holes in the bottom of the power terminal cover base on the UPS cabinet for the UPS rectifier input conduit. Refer to the applicable Eaton 93E UPS Installation and Operation manual listed in paragraph 1.6 for UPS cabinet conduit landing location.
8. Install conduit between the UPS cabinet and the ITC.
9. Route the UPS rectifier input wiring (phase A, B, and C, Neutral and Ground) from the ITC through the wire tray and the conduit to the UPS terminal block on the back of the UPS. See Figure 4-10 or Figure 4-13 for ITC terminal locations. See paragraph 3.2.2, Table 3-4, and Table 3-5 for ITC wiring and termination requirements. Refer to the applicable Eaton 93E UPS Installation and Operation manual listed in paragraph 1.6 for their respective terminal locations and termination requirements.
10. Connect phase A, B, C, Neutral, and Ground rectifier input power wiring from the ITC to the UPS rectifier input, neutral, and ground terminals. See paragraph 3.2.2 for wiring and termination requirements.
11. Connect phase A, B, C, Neutral, and Ground ITC output power wiring to the ITC AC output to UPS, neutral, and ground terminals. See paragraph 3.2.2 for wiring and termination requirements.
12. Route the UPS output wiring (phase A, B, and C and Ground) from the ITC through the wire tray and the conduit to the UPS terminal block on the back of the UPS. See Figure 4-10 or Figure 4-13 for ITC terminal locations. See paragraph 3.2.2, Table 3-4, and Table 3-5 for ITC wiring and termination requirements. Refer to the applicable Eaton 93E UPS Installation and Operation manual listed in paragraph 1.6 for their respective terminal locations and termination requirements.
13. Connect phase A, B, C and Ground UPS output power wiring from the ITC to the UPS output and ground terminals. See paragraph 3.2.2 for wiring and termination requirements.
14. Connect phase A, B, C and Ground ITC output power wiring to the ITC AC output to UPS and ground terminals. See paragraph 3.2.2 for wiring and termination requirements.
15. Install conduit between the ITC and the critical load or Integrated Accessory Cabinet-Bypass (IAC-D). Refer to the *Eaton 93E Integrated Accessory Cabinet-Distribution Installation Manual* listed in paragraph 1.6 for conduit and terminal locations and termination requirements.
16. Route the critical load output wiring (phase A, B, and C, Neutral and Ground) through the wire tray and the conduit on the back of the ITC to the ITC AC output to critical load terminals. See Figure 4-10 or Figure 4-13 for ITC terminal locations. See paragraph 3.2.2, Table 3-4, and Table 3-5 for ITC wiring and termination requirements.
17. Connect phase A, B, C, Neutral, and Ground output power wiring from the critical load or IAC-D to the ITC AC output to critical load, neutral, and ground terminals. See paragraph 3.2.2 for wiring and termination requirements.
18. Install the power terminal cover top using the provided hardware (see Figure 4-17).
19. Install the power terminal cover right and left sides using the provided hardware (see Figure 4-17).
20. Skip to Step 37.

21. Route the UPS rectifier input wiring (phase A, B, and C, Neutral and Ground) from the ITC through the power terminal cover base wiring channels (see Figure 4-16) and the wire tray on the back of the ITC to the ITC AC input to transformer terminals. See Figure 4-10 or Figure 4-13 for ITC terminal locations. See paragraph 3.2.2, Table 3-4, and Table 3-5 for ITC wiring and termination requirements. Refer to the applicable Eaton 93E UPS Installation and Operation manual listed in paragraph 1.6 for their respective terminal locations and termination requirements.
22. Connect phase A, B, C, Neutral, and Ground rectifier input power wiring from the ITC to the UPS rectifier input, neutral, and ground terminals. See paragraph 3.2.2 for wiring and termination requirements.
23. Connect phase A, B, C, Neutral, and Ground ITC output power wiring to the ITC AC output to UPS, neutral, and ground terminals. See paragraph 3.2.2 for wiring and termination requirements.
24. Route the UPS output wiring (phase A, B, and C and Ground) from the ITC through the wire tray and the power terminal cover base wiring channels (see Figure 4-16) to the UPS terminal block on the back of the UPS. See Figure 4-10 or Figure 4-13 for ITC terminal locations. See paragraph 3.2.2, Table 3-4, and Table 3-5 for ITC wiring and termination requirements. Refer to the applicable Eaton 93E UPS Installation and Operation manual listed in paragraph 1.6 for their respective terminal locations and termination requirements.
25. Connect phase A, B, C and Ground UPS output power wiring from the ITC to the UPS output and ground terminals. See paragraph 3.2.2 for wiring and termination requirements.
26. Connect phase A, B, C and Ground ITC output power wiring to the ITC AC output to UPS and ground terminals. See paragraph 3.2.2 for wiring and termination requirements.
27. If wiring to an IAC-D, continue to Step 28; otherwise, skip to Step 30.
28. Route the critical load output wiring (phase A, B, and C, Neutral and Ground) from the IAC-D through the power terminal cover base wiring channels (see Figure 4-16) and the wire tray on the back of the ITC to the ITC AC output to critical load terminals. See Figure 4-10 or Figure 4-13 for ITC terminal locations. See paragraph 3.2.2, Table 3-4, and Table 3-5 for ITC wiring and termination requirements. Refer to the *Eaton 93E Integrated Accessory Cabinet-Distribution Installation Manual* listed in paragraph 1.6 for conduit and terminal locations and termination requirements.
29. Skip to Step 32.
30. Install conduit between the ITC and the critical load.
31. Route the critical load output wiring (phase A, B, and C, Neutral and Ground) through the conduit and the wire tray (Figure 4-8 or Figure 4-9) on the back of the ITC to the ITC AC output to critical load terminals. See Figure 4-10 or Figure 4-13 for ITC terminal locations. See paragraph 3.2.2, Table 3-4, and Table 3-5 for ITC wiring and termination requirements.
32. Connect phase A, B, C, Neutral, and Ground output power wiring from the critical load or IAC-D to the ITC AC output to critical load, neutral, and ground terminals. See paragraph 3.2.2 for wiring and termination requirements.
33. Secure the power cables to the power terminal cover base using wire ties after all electrical connections have been completed.
34. Install the power terminal cover tops using the provided hardware (see Figure 4-18).
35. Install the ITC left side power terminal cover and the UPS right side power terminal cover using the provided hardware (see Figure 4-18).
36. Install the splice cover using the provided hardware (see Figure 4-18).
37. Reinstall the internal safety shield panel removed in Step 2.
38. Close the outside door and secure the latch.
39. After the ITC is installed and wired, return to the applicable Eaton 93E UPS Installation and Operation manual listed in paragraph 1.6 to complete the UPS wiring.

4.4.3 Dual-Feed UPS with Two Input Transformers

To install wiring to connections:

1. If not already open, open the front door by lifting the latch from the bottom and turning to the right (counterclockwise) and swing the door open (see Figure 4-1 or Figure 4-4).
2. Remove the screws securing the internal safety shield panel and remove the panel to gain access to the input and output breaker terminals. Retain the hardware for later use.
3. Install conduit between the utility sources and ITC1 and ITC2.
4. Route the AC utility source input wiring (phase A, B, and C, and Ground) through the conduit and the wire tray (Figure 4-8 or Figure 4-9) on the back of the ITC1 to the ITC AC input to transformer terminals. See Figure 4-10 or Figure 4-13 for ITC terminal locations. See paragraph 3.2.2, Table 3-4, and Table 3-5 for ITC wiring and termination requirements.
5. Connect phase A, B, C, and ground ITC1 input power wiring from the utility source to the ITC AC input to transformer terminals and ground terminals. See paragraph 3.2.2 for wiring and termination requirements.
6. Route the AC utility source input wiring (phase A, B, and C, and Ground) through the conduit and the wire tray (Figure 4-8 or Figure 4-9) on the back of the ITC2 to the ITC AC input to transformer terminals. See Figure 4-10 or Figure 4-13 for ITC terminal locations. See paragraph 3.2.2, Table 3-4, and Table 3-5 for ITC wiring and termination requirements.
7. Connect phase A, B, C, and ground ITC2 input power wiring from the utility source to the ITC AC input to transformer terminals and ground terminals. See paragraph 3.2.2 for wiring and termination requirements.
8. If installing wiring using conduit, continue to Step 9; if using the power terminal cover base channels, skip to Step 19.
9. Punch or drill holes in the bottom of the power terminal cover base on the UPS cabinet for the UPS rectifier and bypass input conduits. Refer to the applicable Eaton 93E UPS Installation and Operation manual listed in paragraph 1.6 for UPS cabinet conduit landing location.
10. Install conduits between the UPS cabinet and ITC1 and ITC2.
11. Route the UPS rectifier and bypass input wiring (phase A, B, and C, Neutral and Ground) from ITC1 and ITC2 through the wire tray and the conduit to the UPS terminal blocks on the back of the UPS. See Figure 4-10 or Figure 4-13 for ITC terminal locations. See paragraph 3.2.2, Table 3-4, and Table 3-5 for ITC wiring and termination requirements. Refer to the applicable Eaton 93E UPS Installation and Operation manual listed in paragraph 1.6 for their respective terminal locations and termination requirements.
12. Connect phase A, B, C, Neutral, and Ground rectifier input power wiring from ITC1 to the UPS rectifier input, neutral, and ground terminals. See paragraph 3.2.2 for wiring and termination requirements.
13. Connect phase A, B, C, Neutral, and Ground ITC1 output power wiring to the ITC1 AC output to UPS, neutral, and ground terminals. See paragraph 3.2.2 for wiring and termination requirements.
14. Connect phase A, B, C, Neutral, and Ground bypass input power wiring from the ITC2 to the UPS bypass input, neutral, and ground terminals. See paragraph 3.2.2 for wiring and termination requirements.
15. Connect phase A, B, C, Neutral, and Ground ITC2 output power wiring to the ITC2 AC output to UPS, neutral, and ground terminals. See paragraph 3.2.2 for wiring and termination requirements.
16. Install the power terminal cover top using the provided hardware (see Figure 4-17).
17. Install the power terminal cover right and left sides using the provided hardware (see Figure 4-17).
18. Skip to Step 28.

19. Route the UPS rectifier and bypass input wiring (phase A, B, and C, Neutral and Ground) from ITC1 and ITC2 through the wire tray and the power terminal cover base wiring channels (see Figure 4-16) on the back of the ITC to the UPS terminal block on the back of the UPS. See Figure 4-10 or Figure 4-13 for ITC terminal locations. See paragraph 3.2.2, Table 3-4, and Table 3-5 for ITC wiring and termination requirements. Refer to the applicable Eaton 93E UPS Installation and Operation manual listed in paragraph 1.6 for their respective terminal locations and termination requirements.
20. Connect phase A, B, C, Neutral, and Ground rectifier input power wiring from the ITC1 to the UPS rectifier input, neutral, and ground terminals. See paragraph 3.2.2 for wiring and termination requirements.
21. Connect phase A, B, C, Neutral, and Ground ITC output power wiring to the ITC1 AC output to UPS, neutral, and ground terminals. See paragraph 3.2.2 for wiring and termination requirements.
22. Connect phase A, B, C, Neutral, and Ground bypass input power wiring from the ITC2 to the UPS bypass input, neutral, and ground terminals. See paragraph 3.2.2 for wiring and termination requirements.
23. Connect phase A, B, C, Neutral, and Ground ITC2 output power wiring to the ITC2 AC output to UPS, neutral, and ground terminals. See paragraph 3.2.2 for wiring and termination requirements.
24. Secure the power cables to the power terminal cover base using wire ties after all electrical connections have been completed.
25. Install the power terminal cover tops using the provided hardware (see Figure 4-18).
26. Install the ITC left side power terminal cover and the UPS right side power terminal cover using the provided hardware (see Figure 4-18).
27. Install the splice cover using the provided hardware (see Figure 4-18).
28. Reinstall the internal safety shield panel removed in Step 2.
29. Close the outside door and secure the latch.
30. After the ITC is installed and wired, return to the applicable Eaton 93E UPS Installation and Operation manual listed in paragraph 1.6 to complete the UPS wiring.

4.4.4 Dual-Feed UPS with Two Input Transformers and One Output Transformer

To install wiring to connections:

1. If not already open, open the front door by lifting the latch from the bottom and turning to the right (counterclockwise) and swing the door open (see Figure 4-1 or Figure 4-4).
2. Remove the screws securing the internal safety shield panel and remove the panel to gain access to the input and output breaker terminals. Retain the hardware for later use.
3. Install conduit between the utility sources and ITC1 and ITC2.
4. Route the AC utility source input wiring (phase A, B, and C, and Ground) through the conduit and the wire tray (Figure 4-8 or Figure 4-9) on the back of the ITC1 to the ITC AC input to transformer terminals. See Figure 4-10 or Figure 4-13 for ITC terminal locations. See paragraph 3.2.2, Table 3-4, and Table 3-5 for ITC wiring and termination requirements.
5. Connect phase A, B, C, and ground ITC1 input power wiring from the utility source to the ITC AC input to transformer terminals and ground terminals. See paragraph 3.2.2 for wiring and termination requirements.
6. Route the AC utility source input wiring (phase A, B, and C, and Ground) through the conduit and the wire tray (Figure 4-8 or Figure 4-9) on the back of the ITC2 to the ITC AC input to transformer terminals. See Figure 4-10 or Figure 4-13 for ITC terminal locations. See paragraph 3.2.2, Table 3-4, and Table 3-5 for ITC wiring and termination requirements.
7. Connect phase A, B, C, and ground ITC2 input power wiring from the utility source to the ITC AC input to transformer terminals and ground terminals. See paragraph 3.2.2 for wiring and termination requirements.

8. If installing wiring using conduit, continue to Step 9; if using the power terminal cover base channels, skip to Step 30.
9. Punch or drill holes in the bottom of the power terminal cover base on the UPS cabinet for the UPS rectifier and bypass input conduits. Refer to the applicable Eaton 93E UPS Installation and Operation manual listed in paragraph 1.6 for UPS cabinet conduit landing location.
10. Install conduits between the UPS cabinet and ITC1 and ITC2.
11. Route the UPS rectifier and bypass input wiring (phase A, B, and C, Neutral and Ground) from ITC1 and ITC2 through the wire tray and the conduit to the UPS terminal blocks on the back of the UPS. See Figure 4-10 or Figure 4-13 for ITC terminal locations. See paragraph 3.2.2, Table 3-4, and Table 3-5 for ITC wiring and termination requirements. Refer to the applicable Eaton 93E UPS Installation and Operation manual listed in paragraph 1.6 for their respective terminal locations and termination requirements.
12. Connect phase A, B, C, Neutral, and Ground rectifier input power wiring from ITC1 to the UPS rectifier input, neutral, and ground terminals. See paragraph 3.2.2 for wiring and termination requirements.
13. Connect phase A, B, C, Neutral, and Ground ITC1 output power wiring to the ITC1 AC output to UPS, neutral, and ground terminals. See paragraph 3.2.2 for wiring and termination requirements.
14. Connect phase A, B, C, Neutral, and Ground bypass input power wiring from the ITC2 to the UPS bypass input, neutral, and ground terminals. See paragraph 3.2.2 for wiring and termination requirements.
15. Connect phase A, B, C, Neutral, and Ground ITC2 output power wiring to the ITC2 AC output to UPS, neutral, and ground terminals. See paragraph 3.2.2 for wiring and termination requirements.
16. Route the UPS output wiring (phase A, B, and C and Ground) from ITC1 through the wire tray and the conduit to the UPS terminal block on the back of the UPS. See Figure 4-10 or Figure 4-13 for ITC terminal locations. See paragraph 3.2.2, Table 3-4, and Table 3-5 for ITC wiring and termination requirements. Refer to the applicable Eaton 93E UPS Installation and Operation manual listed in paragraph 1.6 for their respective terminal locations and termination requirements.
17. Connect phase A, B, C and Ground UPS output power wiring from the ITC1 to the UPS output and ground terminals. See paragraph 3.2.2 for wiring and termination requirements.
18. Connect phase A, B, C and Ground ITC1 output power wiring to the ITC1 AC output to UPS and ground terminals. See paragraph 3.2.2 for wiring and termination requirements.
19. Install conduit between ITC1 and the critical load or Integrated Accessory Cabinet-Bypass (IAC-D). Refer to the *Eaton 93E Integrated Accessory Cabinet-Distribution Installation Manual* listed in paragraph 1.6 for conduit and terminal locations and termination requirements.
20. Route the critical load output wiring (phase A, B, and C, Neutral and Ground) through the wire tray and the conduit on the back of ITC1 to the ITC1 AC output to critical load terminals. See Figure 4-10 or Figure 4-13 for ITC terminal locations. See paragraph 3.2.2, Table 3-4, and Table 3-5 for ITC wiring and termination requirements.
21. Connect phase A, B, C, Neutral, and Ground output power wiring from the critical load or IAC-D to the ITC1 AC output to critical load, neutral, and ground terminals. See paragraph 3.2.2 for wiring and termination requirements.
22. Install the power terminal cover top using the provided hardware (see Figure 4-17).
23. Install the power terminal cover right and left sides using the provided hardware (see Figure 4-17).
24. Skip to Step 43.
25. Route the UPS rectifier and bypass input wiring (phase A, B, and C, Neutral and Ground) from ITC1 and ITC2 through the wire tray and the power terminal cover base wiring channels (see Figure 4-16) on the back of the ITC to the UPS terminal block on the back of the UPS. See Figure 4-10 or Figure 4-13 for ITC terminal locations. See paragraph 3.2.2, Table 3-4, and Table 3-5 for ITC wiring and termination requirements. Refer to the applicable Eaton 93E UPS Installation and Operation manual listed in paragraph 1.6 for their respective terminal locations and termination requirements.

26. Connect phase A, B, C, Neutral, and Ground rectifier input power wiring from the ITC1 to the UPS rectifier input, neutral, and ground terminals. See paragraph 3.2.2 for wiring and termination requirements.
27. Connect phase A, B, C, Neutral, and Ground ITC output power wiring to the ITC1 AC output to UPS, neutral, and ground terminals. See paragraph 3.2.2 for wiring and termination requirements.
28. Connect phase A, B, C, Neutral, and Ground bypass input power wiring from the ITC2 to the UPS bypass input, neutral, and ground terminals. See paragraph 3.2.2 for wiring and termination requirements.
29. Connect phase A, B, C, Neutral, and Ground ITC2 output power wiring to the ITC2 AC output to UPS, neutral, and ground terminals. See paragraph 3.2.2 for wiring and termination requirements.
30. Route the UPS output wiring (phase A, B, and C and Ground) from the ITC1 through the wire tray and the power terminal cover base wiring channels (see Figure 4-16) to the UPS terminal block on the back of the UPS. See Figure 4-10 or Figure 4-13 for ITC terminal locations. See paragraph 3.2.2, Table 3-4, and Table 3-5 for ITC wiring and termination requirements. Refer to the applicable Eaton 93E UPS Installation and Operation manual listed in paragraph 1.6 for their respective terminal locations and termination requirements.
31. Connect phase A, B, C and Ground UPS output power wiring from the ITC1 to the UPS output and ground terminals. See paragraph 3.2.2 for wiring and termination requirements.
32. Connect phase A, B, C and Ground ITC1 output power wiring to the ITC1 AC output to UPS and ground terminals. See paragraph 3.2.2 for wiring and termination requirements.
33. If wiring to an IAC-D, continue to Step 34; otherwise, skip to Step 36.
34. Route the critical load output wiring (phase A, B, and C, Neutral and Ground) from the IAC-D through the power terminal cover base wiring channels (see Figure 4-16) and the wire tray on the back of the ITC1 to the ITC1 AC output to critical load terminals. See Figure 4-10 or Figure 4-13 for ITC terminal locations. See paragraph 3.2.2, Table 3-4, and Table 3-5 for ITC wiring and termination requirements. Refer to the *Eaton 93E Integrated Accessory Cabinet-Distribution Installation Manual* listed in paragraph 1.6 for conduit and terminal locations and termination requirements.
35. Skip to Step 38.
36. Install conduit between ITC1 and the critical load.
37. Route the critical load output wiring (phase A, B, and C, Neutral and Ground) through the conduit and the wire tray (Figure 4-8 or Figure 4-9) on the back of the ITC1 to the ITC1 AC output to critical load terminals. See Figure 4-10 or Figure 4-13 for ITC terminal locations. See paragraph 3.2.2, Table 3-4, and Table 3-5 for ITC wiring and termination requirements.
38. Connect phase A, B, C, Neutral, and Ground output power wiring from the critical load or IAC-D to the ITC1 AC output to critical load, neutral, and ground terminals. See paragraph 3.2.2 for wiring and termination requirements.
39. Secure the power cables to the power terminal cover base using wire ties after all electrical connections have been completed.
40. Install the power terminal cover tops using the provided hardware (see Figure 4-18).
41. Install the ITC left side power terminal cover and the UPS right side power terminal cover using the provided hardware (see Figure 4-18).
42. Install the splice cover using the provided hardware (see Figure 4-18).
43. Reinstall the internal safety shield panel removed in Step 2.
44. Close the outside door and secure the latch.
45. After the ITC is installed and wired, return to the applicable Eaton 93E UPS Installation and Operation manual listed in paragraph 1.6 to complete the UPS wiring.

4.5 Initial Startup

Startup and operational checks must be performed by an authorized Eaton Customer Service Engineer, or the warranty terms specified on page W-1 become void. This service is offered as part of the sales contract for the UPS. Contact an Eaton service representative in advance (usually a two-week notice is required) to reserve a preferred startup date.

4.6 Completing the Installation Checklist

The final step in installing the ITC is completing the following Installation Checklist. This checklist ensures that you have completely installed all hardware, cables, and other equipment. Complete all items listed on the checklist to ensure a smooth installation. Make a copy of the Installation Checklist before filling it out, and retain the original.

After the installation is complete, an Eaton Customer Service Engineer must verify the operation of the UPS system and commission it to support the critical load. The service representative cannot perform any installation tasks other than verifying software and operating setup parameters. Service personnel may request a copy of the completed Installation Checklist to verify all applicable equipment installations have been completed.

**NOTE**

The Installation Checklist **MUST** be completed prior to starting the UPS system for the first time.

Installation Checklist

- All packing materials and restraints have been removed from each cabinet.
- The ITC is installed on a level floor suitable for computer or electronic equipment.
- The ITC is placed in its installed location
- All conduits and cables are properly routed between the ITC, UPS, and IAC-B.
- All power cables are properly sized and terminated.
- A ground conductor is properly installed.
- All terminal cover plates are installed.
- Air conditioning equipment is installed and operating correctly.
- The area around the UPS system is clean and dust-free.
- Adequate workspace exists around the ITC and other cabinets.
- Adequate lighting is provided around all ITC and UPS equipment.
- A 120 Vac service outlet is located within 7.5 meters (25 feet) of the ITC and UPS equipment.
- Startup and operational checks are performed by an authorized Eaton Customer Service Engineer.

Chapter 5 Onelines and Schematics

5.1 Onelines

Figure 5-1 shows the simplified internal structure of the Integrated Transformer Cabinet (ITC) and Figure 5-2 a simplified UPS, EBC, and ITC intercabinet connection diagram.

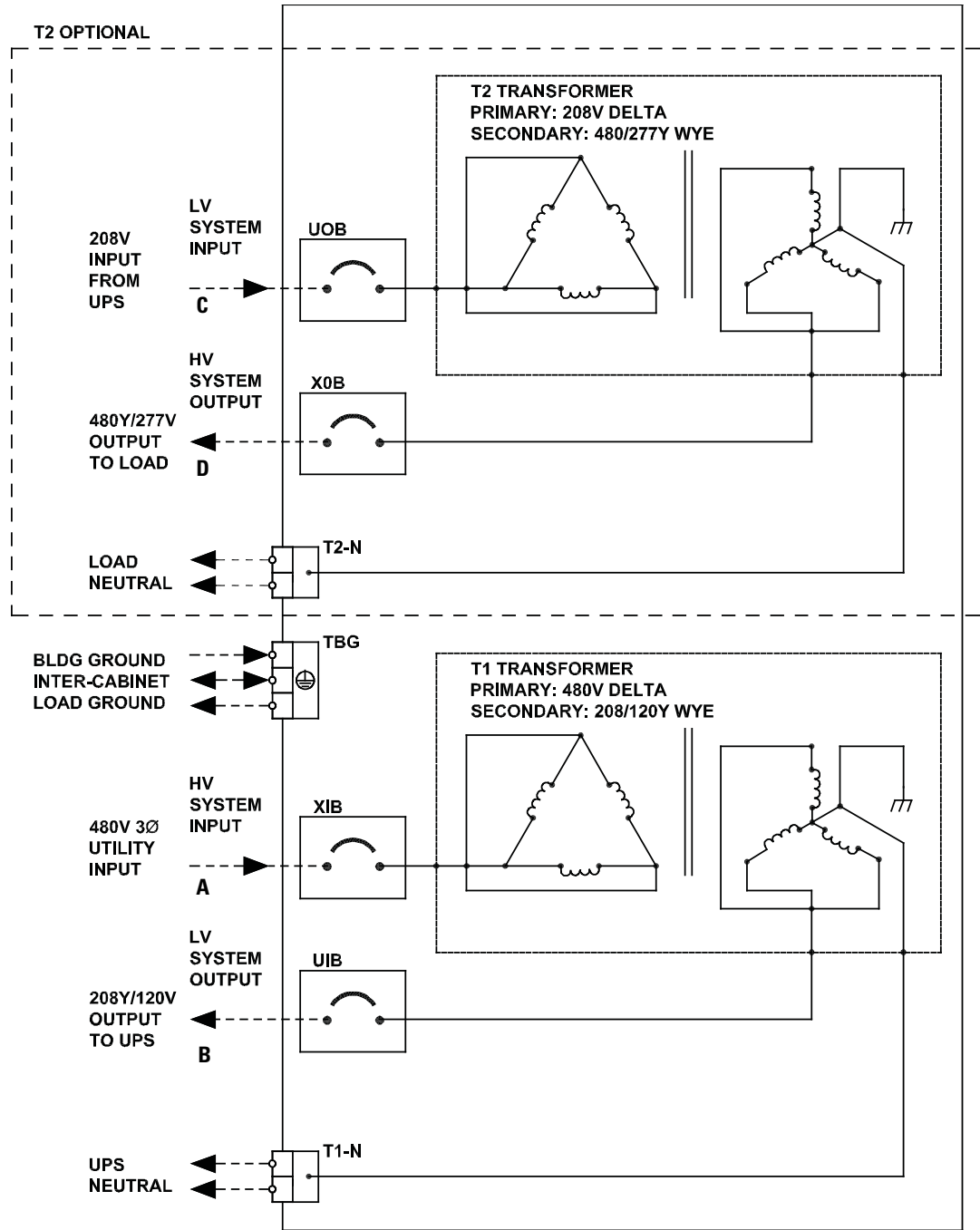

NOTE Callout letters **A** and **B** map to Table 3-4. Callout letters **A**, **B**, **C**, and **D** map to Table 3-5.

Figure 5-1. 93E 30ITC and 93E 60ITC Internal Oneline

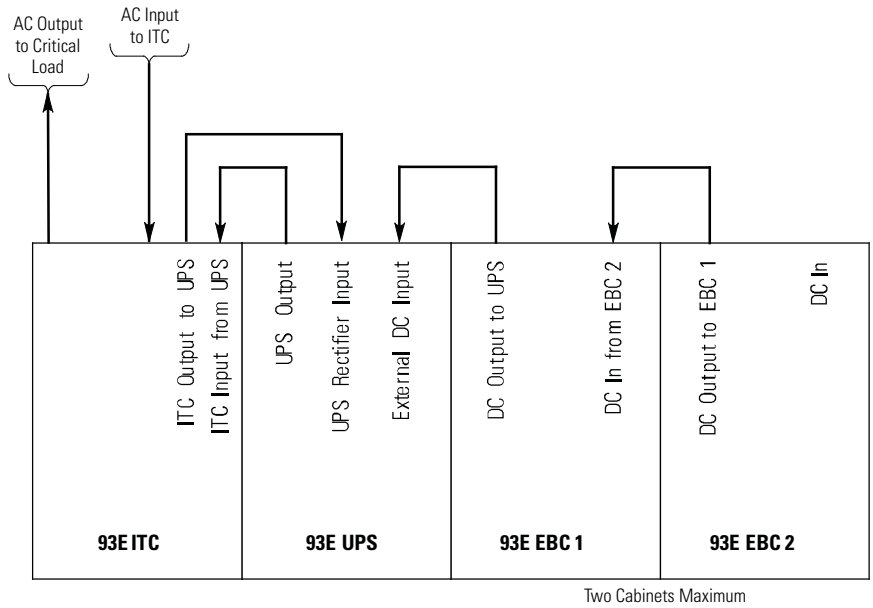

Figure 5-2. Dual Transformer 93E 30ITC and 93E 60ITC Intercabinet Interconnection Oneline

5.2 Schematics

Figure 5-3 shows the 93E 30ITC and 93E 60ITC schematics.

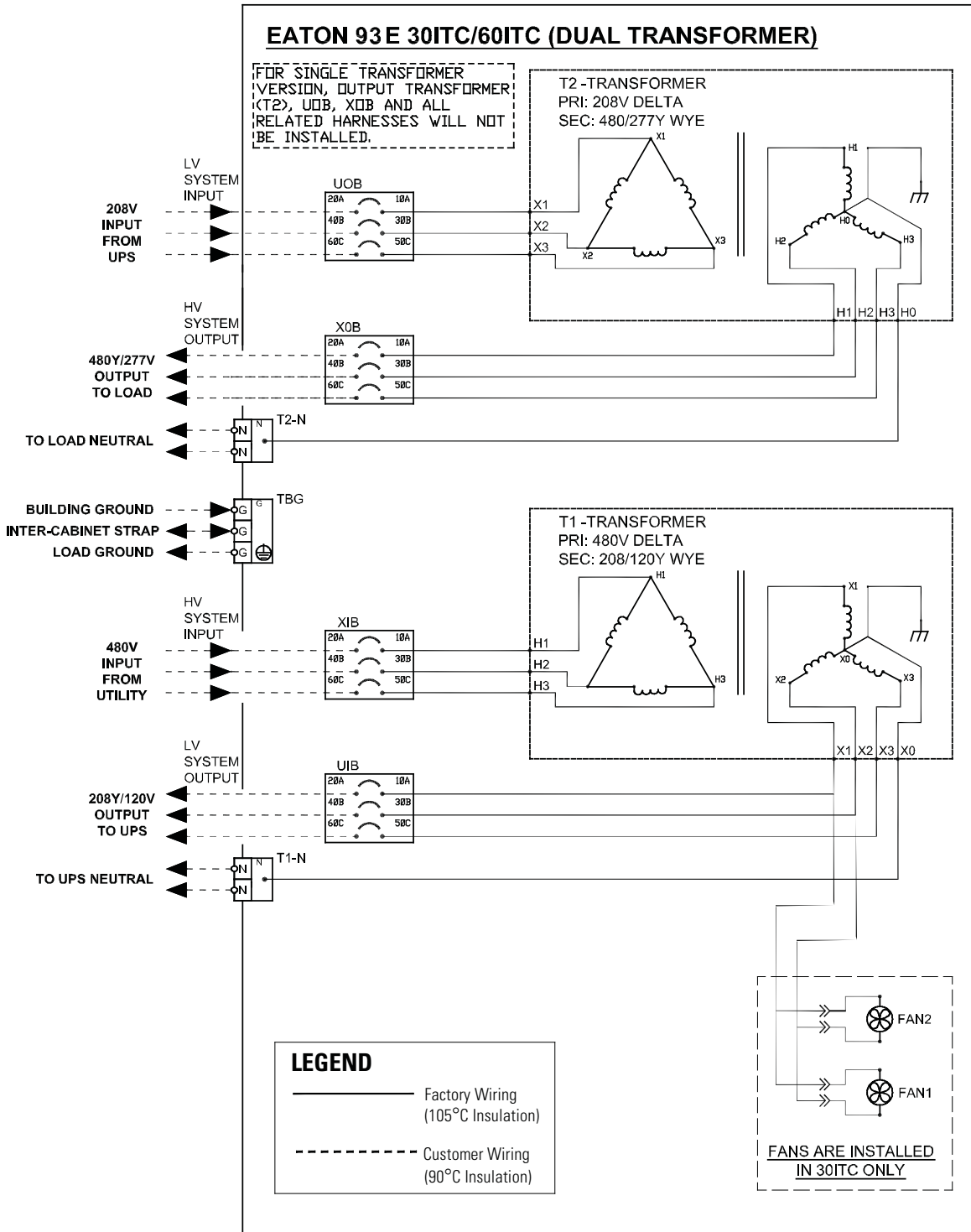

Figure 5-3. 93E 30ITC and 93E 60ITC Schematic

This page intentionally left blank.

Chapter 6 Maintenance

The components inside the Integrated Transformer Cabinet (ITC) are secured to a sturdy metal frame. All repairable parts and assemblies are located for easy removal, with very little disassembly. This design allows authorized service personnel to perform routine maintenance and servicing quickly.

You must schedule periodic performance checks of the UPS system to keep it running properly. Regular routine checks of operation and system parameters enable your system to function efficiently for many trouble-free years.

6.1 Important Safety Instructions

Remember that your UPS system is designed to supply power **EVEN WHEN DISCONNECTED FROM THE UTILITY POWER.**

 **WARNING**

- No user serviceable components.
 - Servicing and maintenance should be performed by qualified service personnel only.
 - **LETHAL VOLTAGE PRESENT.** This unit should not be operated with the cabinet doors open or protective panels removed. Do not make any assumptions about the electrical state of any cabinet in the UPS system.
-

6.2 Performing Preventive Maintenance

The UPS system requires very little preventive maintenance. However, the system should be inspected periodically to verify that the units are operating normally. Record maintenance results and any corrective actions in a suitable log.

6.2.1 DAILY Maintenance

Perform the following steps daily:

1. Check the area surrounding the UPS system. Ensure the area is not cluttered, allowing free access to the unit.
2. Ensure the air intakes on the Accessory cabinets are not blocked.
3. Ensure the operating environment is within the parameters specified in paragraph 3.2.1 and Chapter 7, "Product Specifications."

6.2.2 PERIODIC Maintenance

Periodic inspections of the ITC should be made to determine if components, wiring, and connections exhibit evidence of overheating. Particular attention should be given to the compression lug connections. Maintenance procedures should specify that the compression lug connections be retorqued to values listed in this manual.

6.2.3 ANNUAL Maintenance

Annual preventive maintenance should be performed only by authorized service personnel familiar with maintenance and servicing of the UPS system. Contact an Eaton service representative for more information about service offerings.

6.3 Recycling the ITC

Contact your local recycling or hazardous waste center for information on proper disposal of the ITC.



CAUTION

Do not discard waste electrical or electronic equipment (WEEE) in the trash. For proper disposal, contact your local recycling/reuse or hazardous waste center.

6.4 Maintenance Training

A basic training course, available from Eaton Corporation, gives you a competent working knowledge of the UPS system operation and teaches you how to perform first level corrective maintenance. For more information about training and other services, contact the Help Desk (see paragraph 1.7).

Chapter 7 Product Specifications

This section provides the following specifications:

- Model Numbers
- Input transformer specifications
- Output transformer specifications
- Environmental and safety specifications

7.1 Model Numbers

The Integrated Transformer Cabinet (ITC) is available in two models to meet the needs of the Eaton 93E UPS product line.

Integrated Transformer Cabinet (ITC) Models	Description
Eaton 93E 30ITC	ITC for Eaton 93E 30 kVA UPS
Eaton 93E 60ITC	ITC for Eaton 93E 60 kVA UPS

7.2 Specifications

The following sections detail the input, output, and environmental and safety specifications for the ITC.

7.2.1 Input Transformer

Operating Input Voltage Range	480 Vac nominal (60 Hz)
Input Wiring: 3W + G Operating Frequency Range	60 Hz \pm 5 Hz
Operating Input Current	See Table 3-4 and Table 3-5
Operating Output Voltage Range	208Y/120 Vac nominal (60 Hz)
Output Wiring: 4W + G Operating Frequency Range	60 Hz \pm 5 Hz
Operating Output Current	See Table 3-4 and Table 3-5

7.2.2 Output Transformer

Operating Input Voltage Range	208 Vac nominal (60 Hz)
Input Wiring: 3W + G Operating Frequency Range	60 Hz \pm 5 Hz
Operating Input Current	See Table 3-4 and Table 3-5
Operating Output Voltage Range	480 Y/277 Vac nominal (60 Hz)
Output Wiring: 4W + G Operating Frequency Range	60 Hz \pm 5 Hz
Operating Output Current	See Table 3-4 and Table 3-5

7.2.3 Environmental and Safety Specifications

Operating Temperature	32°F to 86°F (0°C to 30°C).
Transit Temperature	-13°F to 140°F (-25°C to 60°C)
Storage Temperature	-13°F to 131°F (-25°C to 55°C)
Operating Altitude	Maximum 1500m (5000 ft) at 30°C without derating
Transit Altitude	15000m (49213 ft)
Ventilation	30ITC – forced air cooling 60ITC – convection
Relative Humidity (operating and storage)	5% to 95% maximum noncondensing
Acoustical Noise	Not applicable
Safety Conformance	UL1778 4 th edition
Agency Markings	ULus
EMC (Class A)	FCC Part 15 Class A and 62040-2 c3

Warranty

LIMITED FACTORY WARRANTY FOR THREE-PHASE EATON® 93E UPS AND 93E UPS ACCESSORY PRODUCTS

WARRANTOR: The warrantor for the limited warranties set forth herein is Eaton Corporation, an Ohio Corporation ("Eaton").

LIMITED WARRANTY: This limited warranty (this "Warranty") applies only to the original end-user (the "End-User") of the Eaton Three-Phase 93E UPS and 93E UPS Accessory Products (the "Product") and cannot be transferred. This restriction applies even in the event that the Product is initially sold by Eaton for resale to an End-User. This Warranty gives you specific legal rights, and you may also have other rights which vary from State to State (or jurisdiction to jurisdiction).

WHAT THIS LIMITED WARRANTY COVERS: The warrantor warrants, with the terms of this Warranty, that the Eaton three-phase UPS electronics, Eaton-built accessories, and Eaton-built battery cabinets (individually and collectively, the "Warranted Items") are free from defects in material and workmanship.

For Product installed (and currently located) in the fifty (50) United States and the District of Columbia, if, in the opinion of Eaton, a Warranted Item is defective, Eaton's sole obligation, at the option of Eaton, will be to refurbish or replace such defective Warranted Item (including the costs of providing diagnosis, service, and labor ["labor coverage"]). The defective Warranted Item will be refurbished or replaced onsite at the End-User's location or such other location as determined by Eaton. Any parts that are replaced may be new or reconditioned. All parts replaced by Eaton shall become the property of Eaton.

For Product installed (and currently located) outside the fifty (50) United States and the District of Columbia, if, in the opinion of Eaton, a Warranted Item is defective, Eaton's sole obligation, at the option of Eaton, will be to refurbish or replace such defective Warranted Item (not including the costs of labor coverage). The defective Warranted Item will be refurbished or replaced onsite at the End-User's location or such other location as determined by Eaton. Any parts that are replaced may be new or reconditioned. All parts replaced by Eaton shall become the property of Eaton.

LIMITED WARRANTY PERIOD: The period covered by this Warranty for Product installed (and currently located) in the fifty (50) United States and the District of Columbia is six (6) months from the date of Product purchase for labor coverage when no startup is performed by an authorized Eaton Customer Service Engineer or Agent or twelve (12) months from the date of Product purchase with startup performed by an authorized Eaton Customer Service Engineer or Agent and twelve (12) months from the date of Product purchase or eighteen (18) months from date of Product shipment, whichever occurs first, for the refurbishment/ replacement of parts.

The period covered by this Warranty for Product installed (and currently located) outside the fifty (50) United States and the District of Columbia is twelve (12) months from the date of Product purchase or eighteen (18) months from the date of Product shipment, whichever occurs first, for the refurbishment/replacement of parts.

WHAT THIS LIMITED WARRANTY DOES NOT COVER: This Warranty does not cover any defects or damages caused by: (a) failure to properly store the Product before installation, including the "trickle charge" of batteries no later than the date indicated on the packaging; (b) shipping and delivery of the Product if shipping is FOB Factory; (c) neglect, accident, fire, flood, lightning, vandalism, acts of God, Customer's neglect, abuse, misuse, misapplication, incorrect installation; (d) repair or alteration not authorized in writing by Eaton personnel or performed by an authorized Eaton Customer Service Engineer or Agent; or (e) improper testing, operation, maintenance, adjustment, or any modification of any kind not authorized in writing by Eaton personnel or performed by an authorized Eaton Customer Service Engineer or Agent.

This Warranty is not valid: if the Product's serial numbers have been removed or are illegible. Any Warranted Items repaired or replaced pursuant to this Warranty will be warranted for the remaining portion of the original Warranty subject to all the terms thereof. Eaton does not provide a labor warranty for Product located outside of the fifty (50) United States or the District of Columbia. **Any equipment, parts, or materials included in the Product and not manufactured by Eaton are warranted solely by the manufacturer of such equipment, parts, or materials and are not included as part of this Warranty. Batteries are not warranted by Eaton.**

THIS WARRANTY IS THE END-USER'S SOLE REMEDY AND IS EXPRESSLY IN LIEU OF, AND THERE ARE NO OTHER, EXPRESSED OR IMPLIED GUARANTEES OR WARRANTIES (INCLUDING ANY IMPLIED WARRANTY OF MERCHANTABILITY OR FITNESS FOR ANY PURPOSE, WHICH ARE EXPRESSLY DISCLAIMED). SOME STATES OR JURISDICTIONS DO NOT ALLOW THE EXCLUSION OF EXPRESS OR IMPLIED WARRANTIES, SO THE ABOVE EXCLUSION MAY NOT APPLY TO YOU. IN THAT EVENT, SUCH WARRANTIES ARE LIMITED IN DURATION TO THE LIMITED WARRANTY PERIOD. SOME STATES OR JURISDICTIONS DO NOT ALLOW LIMITATIONS ON HOW LONG AN IMPLIED WARRANTY LASTS OR THE EXCLUSION OR LIMITATION OF INCIDENTAL OR CONSEQUENTIAL DAMAGES, SO THE ABOVE LIMITATIONS AND/OR EXCLUSIONS MAY NOT APPLY TO YOU.

LIMITATION OF LIABILITY: In no event shall Eaton be liable for any indirect, incidental, special or consequential damages of any kind or type whatsoever, resulting from or in connection with any claim or cause of action, whether brought in contract or in tort (including negligence and strict liability). Some States or jurisdictions do not allow the exclusion of limitation of incidental or consequential damages, so the above limitation or exclusion may not apply to you. Eaton shall not be responsible for failure to provide service or parts due to causes beyond Eaton's reasonable control. In no case will Eaton's liability under this Warranty exceed the replacement value of the Warranted Items.

END-USER'S OBLIGATIONS: In order to receive the benefits of this Warranty, the End-User must register the product warranty (via mail or online at www.powerquality.eaton.com/Product-Registration "product registration"); use the Product in a normal way; follow the Product's user's guide; and protect against further damage to the Product if there is a covered defect.

OTHER LIMITATIONS: Eaton's obligations under this Warranty are expressly conditioned upon receipt by Eaton of all payments due to it (including interest charges, if any). During such time as Eaton has not received payment of any amount due to it for the Product, in accordance with the contract terms under which the Product is sold, Eaton shall have no obligation under this Warranty. Also during such time, the period of this Warranty shall continue to run and the expiration of this Warranty shall not be extended upon payment of any overdue or unpaid amounts.

COSTS NOT RELATED TO WARRANTY: The End-User shall be invoiced for, and shall pay for, all services not expressly provided for by the terms of this Warranty, including without limitation site calls involving an inspection that determines no corrective maintenance is required. Any costs for replacement equipment, installation, materials, freight charges, travel expenses, or labor of Eaton representatives outside the terms of this Warranty will be borne by the End-User.

OBTAINING WARRANTY SERVICE: In the USA, call the Eaton Customer Reliability Center 7x24 at 800-843-9433. Outside of the USA, call your local Eaton sales or service representative, or call the Eaton Customer Reliability Center in the United States at 919-845-3633. For comments or questions about this Limited Factory Warranty, write to the Customer Quality Representative, 8609 Six Forks Road, Raleigh, North Carolina 27615 USA.



P-16400074 3