

Eaton® 93E Integrated Accessory Cabinet-Distribution

30IAC-D and 60IAC-D
Installation and Operation Manual



Powering Business Worldwide

Eaton® 93E Integrated Accessory Cabinet-Distribution

30IAC-D and 60IAC-D
Installation and Operation Manual



Powering Business Worldwide

IMPORTANT SAFETY INSTRUCTIONS SAVE THESE INSTRUCTIONS

This manual contains important instructions that should be followed during installation and maintenance of the UPS system and batteries. Read all instructions before operating the equipment and save this manual for future reference.

CONSIGNES DE SÉCURITÉ IMPORTANTES CONSERVER CES INSTRUCTIONS

Ce manuel comporte des instructions importantes que vous êtes invité à suivre lors de toute procédure d'installation et de maintenance des batteries et de l'onduleur. Veuillez consulter entièrement ces instructions avant de faire fonctionner l'équipement et conserver ce manuel afin de pouvoir vous y reporter ultérieurement.

Eaton and Cutler-Hammer are registered trademarks of Eaton Corporation or its subsidiaries and affiliates. National Electrical Code and NEC are registered trademarks of National Fire Protection Association, Inc. All other trademarks are property of their respective companies.

©Copyright 2011–2015 Eaton Corporation, Raleigh, NC, USA. All rights reserved. No part of this document may be reproduced in any way without the express written approval of Eaton Corporation.

Table of Contents

| | | |
|---------------------------------|---|------------|
| 1 | INTRODUCTION | 1-1 |
| 1.1 | Features | 1-2 |
| 1.2 | Installation Features | 1-2 |
| 1.3 | Model Configurations | 1-2 |
| 1.4 | Using This Manual | 1-4 |
| 1.5 | Conventions Used in This Manual | 1-4 |
| 1.6 | Symbols, Controls, and Indicators | 1-4 |
| 1.7 | For More Information | 1-5 |
| 1.8 | Getting Help | 1-5 |
| 2 | SAFETY WARNINGS | 2-1 |
| SECTION 1 — INSTALLATION | | |
| 3 | INSTALLATION PLAN AND UNPACKING | 3-1 |
| 3.1 | Creating an Installation Plan | 3-1 |
| 3.2 | Preparing the Site | 3-1 |
| 3.2.1 | Environmental and Installation Considerations | 3-1 |
| 3.2.2 | IAC-D Power Wiring Preparation | 3-9 |
| 3.3 | Inspecting and Unpacking the IAC-D | 3-12 |
| 4 | INSTALLATION | 4-1 |
| 4.1 | Preliminary Installation Information | 4-1 |
| 4.2 | Unloading the IAC-D Cabinet from the Pallet | 4-1 |
| 4.2.1 | Unloading the 30IAC-D | 4-1 |
| 4.2.2 | Unloading the 60IAC-D | 4-6 |
| 4.3 | Installing the Power Terminal Cover Base | 4-11 |
| 4.4 | Installing IAC-D External Power Wiring | 4-13 |
| 4.5 | Initial Startup | 4-22 |
| 4.6 | Completing the Installation Checklist | 4-22 |
| SECTION 2 — OPERATION | | |
| 5 | ONELINES AND SCHEMATICS | 5-1 |
| 5.1 | Onelines | 5-1 |
| 5.2 | Schematics | 5-3 |
| 6 | INTEGRATED ACCESSORY CABINET-DISTRIBUTION OPERATING INSTRUCTIONS | 6-1 |
| 6.1 | IAC-D Breakers | 6-1 |
| 6.2 | IAC-D Operation | 6-3 |
| 7 | MAINTENANCE | 7-1 |
| 7.1 | Important Safety Instructions | 7-1 |
| 7.2 | Performing Preventive Maintenance | 7-1 |
| 7.2.1 | DAILY Maintenance | 7-1 |
| 7.2.2 | PERIODIC Maintenance | 7-1 |
| 7.2.3 | ANNUAL Maintenance | 7-1 |
| 7.3 | Maintenance Training | 7-1 |

Table of Contents

| | | |
|----------|---|------------|
| 8 | PRODUCT SPECIFICATIONS | 8-1 |
| 8.1 | Model Numbers | 8-1 |
| 8.2 | Specifications | 8-1 |
| 8.2.1 | Input | 8-1 |
| 8.2.2 | Output | 8-1 |
| 8.2.3 | Environmental and Safety Specifications | 8-2 |
| | WARRANTY | W-1 |

List of Figures

| | | |
|--------------|---|------|
| Figure 1-1. | Eaton 93E 30IAC-D and Eaton 93E 60IAC-D | 1-1 |
| Figure 1-3. | Eaton 93E 60 kVA UPS and Eaton 93E 60IAC-D | 1-3 |
| Figure 3-2. | 93E 30IAC-D Dimensions (Top and Bottom Views) | 3-4 |
| Figure 3-3. | 93E 30IAC-D Center of Gravity | 3-5 |
| Figure 3-5. | 93E 60IAC-D Dimensions (Top and Bottom Views) | 3-7 |
| Figure 4-3. | Installing the Pallet Extension Plate – 93E 30IAC-D | 4-4 |
| Figure 4-4. | Cabinet Bracket | 4-6 |
| Figure 4-7. | Installing the Pallet Extension Plate – 93E 60IAC-D | 4-9 |
| Figure 4-8. | IAC-D Power Terminal Cover Parts | 4-11 |
| Figure 4-11. | Input Power Terminal Locations – 93E 30IAC-D | 4-15 |
| Figure 4-12. | Input Power Terminal Detail – 93E 30IAC-D and 93E 60IAC-D | 4-16 |
| Figure 4-13. | Input Power Terminal Locations – 93E 60IAC-D | 4-17 |
| Figure 4-14. | IAC-D Power Terminal Cover Installation | 4-18 |
| Figure 4-17. | Output Power Terminal Locations | 4-21 |
| Figure 4-18. | Subfeed Output Terminal Location– 93E 30IAC-D and 93E 60IAC-D | 4-22 |
| Figure 5-2. | 93E 30IAC-D and 93E 60IAC-D Intercabinet Interconnection Online | 5-2 |
| Figure 6-1. | 93E 30IAC-D Breakers. | 6-1 |
| Figure 6-2. | 93E 60IAC-D Breakers. | 6-2 |

This page intentionally left blank.

List of Tables

| | | |
|------------|--|------|
| Table 3-1. | IAC-D Cabinet Weights | 3-2 |
| Table 3-2. | IAC-D Cabinet Clearances | 3-2 |
| Table 3-3. | External Power Wiring Requirements for the Eaton 93E 30IAC-D and 60IAC-D. | 3-10 |
| Table 3-4. | External Input Power Cable Terminations for the Eaton 93E 30IAC-D and 60IAC-D. | 3-10 |
| Table 3-5. | External Output Power Cable Terminations for the Eaton 93E 30IAC-D and 60IAC-D | 3-11 |

This page intentionally left blank.

Chapter 1 Introduction

The Eaton® Integrated Accessory Cabinet-Distribution (IAC-D) is designed for use with the Eaton 93E 20–30 kVA and 40–60 kVA Uninterruptible Power Supply (UPS). The IAC-D provides power distribution options for servers, racks, and other equipment via distribution panelboards, or distributes power to larger loads via distribution subfeed circuit breakers. The distribution options are custom configurable, enabling adaptation and expansion without costly electrical rework. Two models are available, the 93E 30IAC-D and 93E 60IAC-D.

The IAC-D is housed in a single free-standing cabinet with safety shields behind the front door for hazardous voltage protection. The cabinets match the UPS cabinet in style and color.

Figure 1-1 shows the Eaton 93E 30IAC-D and Eaton 93E 60IAC-D.



NOTE Startup and operational checks must be performed by an authorized Eaton Customer Service Engineer, or the warranty terms specified on page W-1 become void. This service is offered as part of the sales contract for the UPS. Contact an Eaton service representative in advance (usually a two-week notice is required) to reserve a preferred startup date.

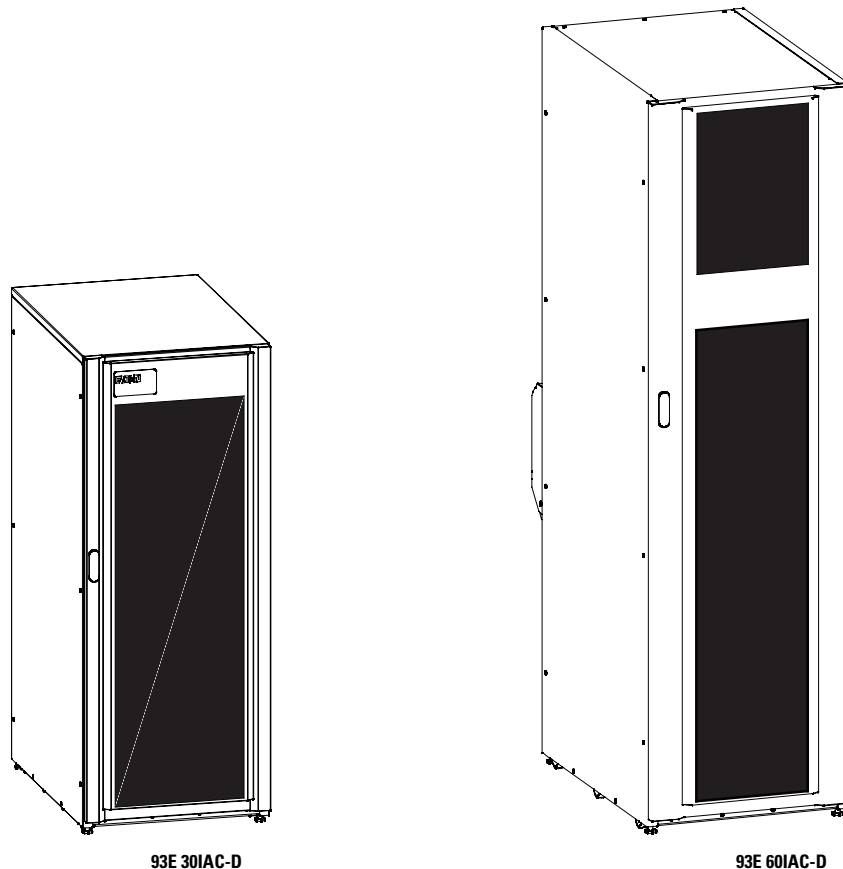

Figure 1-1. Eaton 93E 30IAC-D and Eaton 93E 60IAC-D

1.1 Features

An output distribution panel distributes the output power from the UPS to the load. The distribution panel is behind the door on the front of the IAC-D. The 225A distribution panel with an F-Frame, 3-pole, 80% rated, 225A main breaker can hold up to the equivalent of 42 single-pole branch circuit breakers (Cutler-Hammer® bolt-on type BAB or QBHW) that can be configured to meet facility needs.

Provisions are available for optional subfeed output breakers with three fixed trip ratings for larger loads.

1.2 Installation Features

The IAC-D is designed to be installed in line-up-and-match or standalone configurations. In line-up-and-match configurations input power wiring may be routed either external to the cabinet using conduit or the power terminal wiring channel assembly may be utilized to pass wiring between adjacent cabinets. In standalone configurations input power wiring is routed using external conduit.

To reducing installation time, input connections are made to easily accessible mechanical lug terminals at the back of the cabinet and output connections to distribution breakers located at the front of the cabinet.

A line-up-and-match IAC-D is installed adjacent to the UPS or other accessory cabinet. The recommended installation location is to the left of the UPS cabinet. See Figure 1-2 and Figure 1-3 for line-up-and-match configuration views.

Non-adjacent installation of IAC-Ds require the use of fixed mounting brackets to anchor the cabinet to the floor.

1.3 Model Configurations

The following model configurations are available:

- 93E 30IAC-D for use with the 93E 30 kVA UPS
 - Contains one PRL1a 225A 42-pole distribution panel
 - Up to three EG-Frame 3-pole 125A subfeed breakers
- 93E 60IAC-D for use with the 93E 60 kVA UPS
 - Contains one PRL1a 225A 42-pole distribution panel
 - Up to three JG-Frame 3-pole 250A subfeed breakers

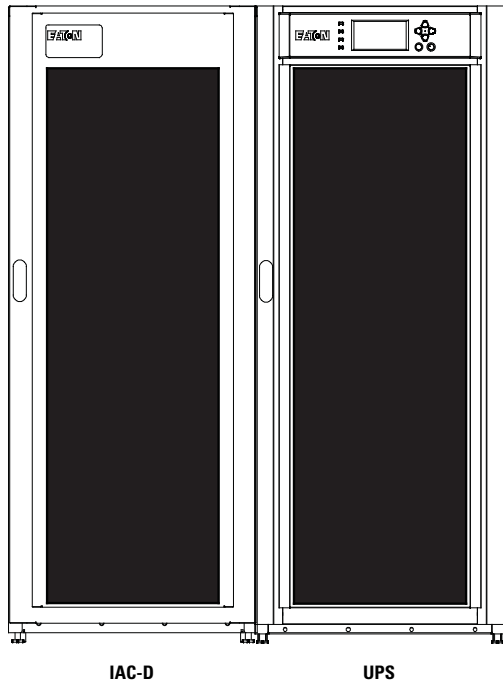

Figure 1-2. Eaton 93E 30 kVA UPS and Eaton 93E 30IAC-D

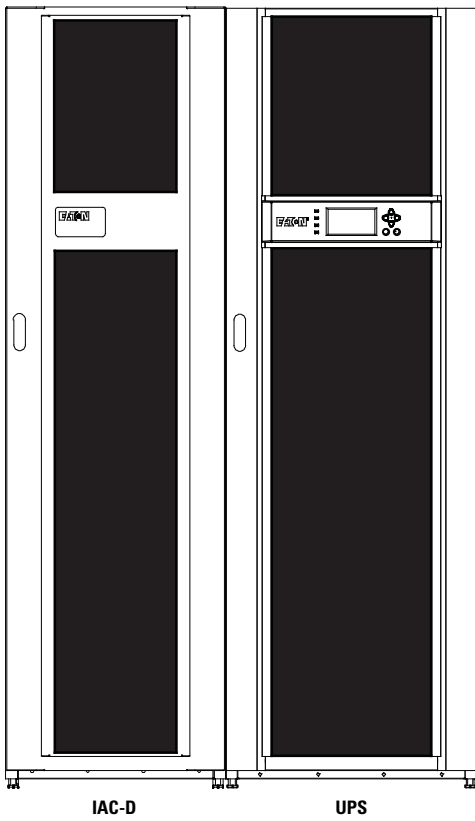

Figure 1-3. Eaton 93E 60 kVA UPS and Eaton 93E 60IAC-D

1.4 Using This Manual

This manual describes how to install the IAC-D. Read and understand the procedures described to ensure trouble-free installation and operation.

Read through each procedure before beginning the procedure. Perform only those procedures that apply to the UPS system being installed or operated.

1.5 Conventions Used in This Manual

This manual uses these type conventions:

- **Bold type** highlights important concepts in discussions, key terms in procedures, and menu options, or represents a command or option that you type or enter at a prompt.
- *Italic type* highlights new terms where they are defined.
- Screen type represents information that appears on the screen or LCD.

| Icon | Description |
|-------------|---|
| NOTE | Information notes provide pertinent information about important features or instructions. |
| [Keys] | Brackets are used when referring to a specific key, such as [Enter] or [Ctrl]. |

In this manual, the term *UPS* refers only to the UPS cabinet and its internal elements. The term *UPS system* refers to the entire power protection system – the UPS cabinet, an external battery system, and options or accessories installed.

The term *line-up-and-match* refers to accessory cabinets that are physically located adjacent to the UPS. The term *standalone* refers to accessory cabinets that are located separate from the UPS.

1.6 Symbols, Controls, and Indicators

The following are examples of symbols used on the UPS or accessories to alert you to important information:



RISK OF ELECTRIC SHOCK - Observe the warning associated with the risk of electric shock symbol.



CAUTION: REFER TO OPERATOR'S MANUAL - Refer to your operator's manual for additional information, such as important operating and maintenance instructions.



This symbol indicates that you should not discard the UPS or the UPS batteries in the trash. This product contains sealed, lead-acid batteries and must be disposed of properly. For more information, contact your local recycling/reuse or hazardous waste center.



This symbol indicates that you should not discard waste electrical or electronic equipment (WEEE) in the trash. For proper disposal, contact your local recycling/reuse or hazardous waste center.

1.7 For More Information

Refer to the *Eaton 93E UPS (20–30 kVA, 208/220V) Installation and Operation Manual* or *Eaton 93E UPS (40–60 kVA, 208/220V) Installation and Operation Manual* for the following additional information:

- UPS, optional components, and accessory installation instructions, including site preparation, planning for installation, wiring and safety information, and detailed illustrations of cabinets and optional accessories with dimensional and connection point drawings
- UPS operation, including UPS controls, functions of the UPS, standard features and optional accessories, procedures for starting and stopping the UPS, and information about maintenance and responding to system events
- Communication capabilities of the UPS system

Refer to the *Eaton 93E Integrated Accessory Cabinet-Tie and Bypass Installation and Operation Manual* for the following additional information:

- Installation instructions, including site preparation, planning for installation, wiring and safety information, and detailed illustrations of cabinets with dimensional and connection point drawings
- Operation, including breakers, standard features and optional accessories, procedures for using the tie and bypass functions, and information about maintenance

Visit www.eaton.com/powerquality or contact an Eaton service representative for information on how to obtain copies of these manuals.

1.8 Getting Help

If help is needed with any of the following:

- Scheduling initial startup
- Regional locations and telephone numbers
- A technical question about any of the information in this manual
- A question this manual does not answer

Please call the Customer Reliability Center at:

| | |
|----------------------|---|
| United States: | 1-800-843-9433 |
| Canada: | 1-800-461-9166 ext 260 |
| All other countries: | Call your local service representative |

Please use the following e-mail address for manual comments, suggestions, or to report an error in this manual:

E-ESSDocumentation@eaton.com

This page intentionally left blank.

Chapter 2 Safety Warnings

IMPORTANT SAFETY INSTRUCTIONS SAVE THESE INSTRUCTIONS

This manual contains important instructions that should be followed during installation and maintenance of the UPS system and batteries. Read all instructions before operating the equipment and save this manual for future reference.

The UPS system is designed for industrial or computer room applications, and contains safety shields behind the door and front panels. However, the UPS system is a sophisticated power system and should be handled with appropriate care.

DANGER

This UPS system contains LETHAL VOLTAGES. All repairs and service should be performed by AUTHORIZED SERVICE PERSONNEL ONLY. There are NO USER SERVICEABLE PARTS inside the UPS.

WARNING

- The UPS system is powered by its own energy source (batteries). The output terminals may carry live voltage even when the UPS is disconnected from an AC source.
 - To reduce the risk of fire or electric shock, install this UPS system in a temperature and humidity controlled, indoor environment, free of conductive contaminants. Ambient temperature must not exceed 30°C (86°F). Do not operate near water or excessive humidity (95% maximum). The system is not intended for outdoor use.
 - As a result of the connected loads, high leakage current is possible. Connection to earth ground is required for safety and proper product operation. Do not check UPS system operation by any action that includes removal of the earth (ground) connection with loads attached.
 - Ensure all power is disconnected before performing installation or service.
 - ELECTRIC ENERGY HAZARD. Do not attempt to alter any UPS system or battery wiring or connectors. Attempting to alter wiring can cause injury.
 - Failure to anchor the cabinet could lead to injury or death. To reduce this risk, the distribution, tie, and bypass cabinets must be secured to the building floor or to an adjacent 93E system cabinet.
-

 **CAUTION**

- Installation or servicing should be performed by qualified service personnel knowledgeable of UPS and battery systems, and required precautions. Keep unauthorized personnel away from equipment. Consider all warnings, cautions, and notes before installing or servicing equipment.
 - Keep the Accessory cabinet doors closed and front panels installed to ensure proper cooling airflow and to protect personnel from dangerous voltages inside the unit.
 - Do not install or operate the UPS system close to gas or electric heat sources.
 - The operating environment should be maintained within the parameters stated in this manual.
 - Keep surroundings uncluttered, clean, and free from excess moisture.
 - Observe all DANGER, WARNING, and CAUTION notices affixed to the inside and outside of the equipment.
-

Section 1

Installation

Chapter 3 Installation Plan and Unpacking

Use the following basic sequence of steps to install the Eaton 93E 30 or 60 Integrated Accessory Cabinet-Distribution (IAC-D):

1. Create an installation plan for the IAC-D (Chapter 3).
2. Prepare your site for the IAC-D (Chapter 3).
3. Inspect and unpack the IAC-D (Chapter 3).
4. Unload and install the IAC-D, and wire the system (Chapter 4).
5. Complete the Installation Checklist (Chapter 4).
6. Have authorized service personnel perform preliminary operational checks and start up the UPS system.

NOTE  Startup and operational checks must be performed by an authorized Eaton Customer Service Engineer, or the warranty terms specified on page W-1 become void. This service is offered as part of the sales contract for the UPS. Contact an Eaton service representative in advance (usually a two-week notice is required) to reserve a preferred startup date.

3.1 Creating an Installation Plan

Before installing the IAC-D, read and understand how this manual applies to the system being installed. Use the procedures and illustrations in this section to create a logical plan for installing the IAC-D. This section contains the following information:

- Physical features and requirements, including dimensions
- Power wiring installation information

3.2 Preparing the Site

For the UPS system to operate at peak efficiency, the installation site should meet the environmental parameters outlined in this manual. If the UPS system is to be operated at an altitude higher than 1000m (3280 ft), contact an Eaton service representative for important information about high altitude operation. The operating environment must meet the weight, clearance, and environmental requirements specified for the applicable accessory cabinet.

3.2.1 Environmental and Installation Considerations

The UPS system installation, including the IAC-D, must meet the following guidelines:

- The system must be installed on a level floor suitable for computer or electronic equipment.
- The system must be installed in a temperature and humidity controlled indoor area free of conductive contaminants.

Failure to follow guidelines may void your warranty.

The IAC-D operating environment must accommodate the weight requirements shown in Table 3-1 and the size and space requirements shown in Table 3-2 and Figure 3-1 through Figure 3-6.

Table 3-1. IAC-D Cabinet Weights

| Model | Shipping | Weight kg (lb) | |
|-------------------|-----------|-------------------|------------------|
| | | Installed | Point Loading |
| Eaton 93E 30IAC-D | 133 (293) | 108 (238) | 6 at 18 (39.7) |
| Eaton 93E 60IAC-D | 168 (370) | 143 (315) | 6 at 23.9 (52.5) |

The IAC-D cabinet uses convection cooling to regulate internal component temperature. Air inlets are in the front of the cabinet and outlets are in the back of the cabinet. Allow clearance in front of and in back of the cabinet for proper air circulation. The clearances required around the IAC-D cabinet are shown in Table 3-2.

Table 3-2. IAC-D Cabinet Clearances

| | |
|-----------------------------------|------------------------------|
| From Top of Cabinet | None Required |
| From Front of Cabinet | 914.4 mm (36") working space |
| From Back of Cabinet | 914.4 mm (36") working space |
| From Right Side of Cabinet | None Required |
| From Left Side of Cabinet | None Required |

The basic environmental requirements for operation of the IAC-D are:

- Recommended Operating Range: 15–25°C (59–77°F)
- Maximum Relative Humidity: 95%, noncondensing

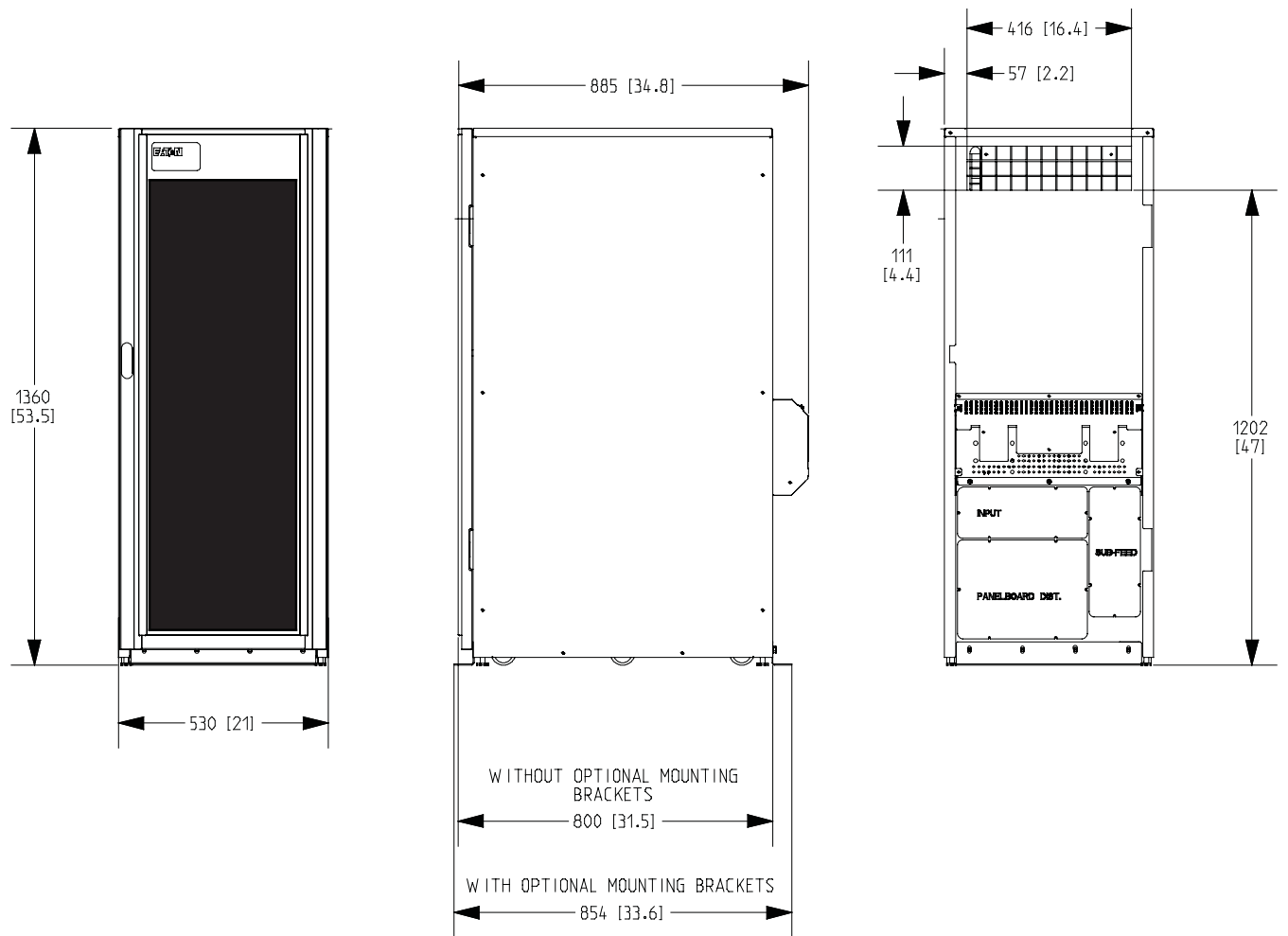

Dimensions are in millimeters [inches]

Figure 3-1. 93E 30IAC-D Cabinet Dimensions (Front, Right Side, and Rear Views)

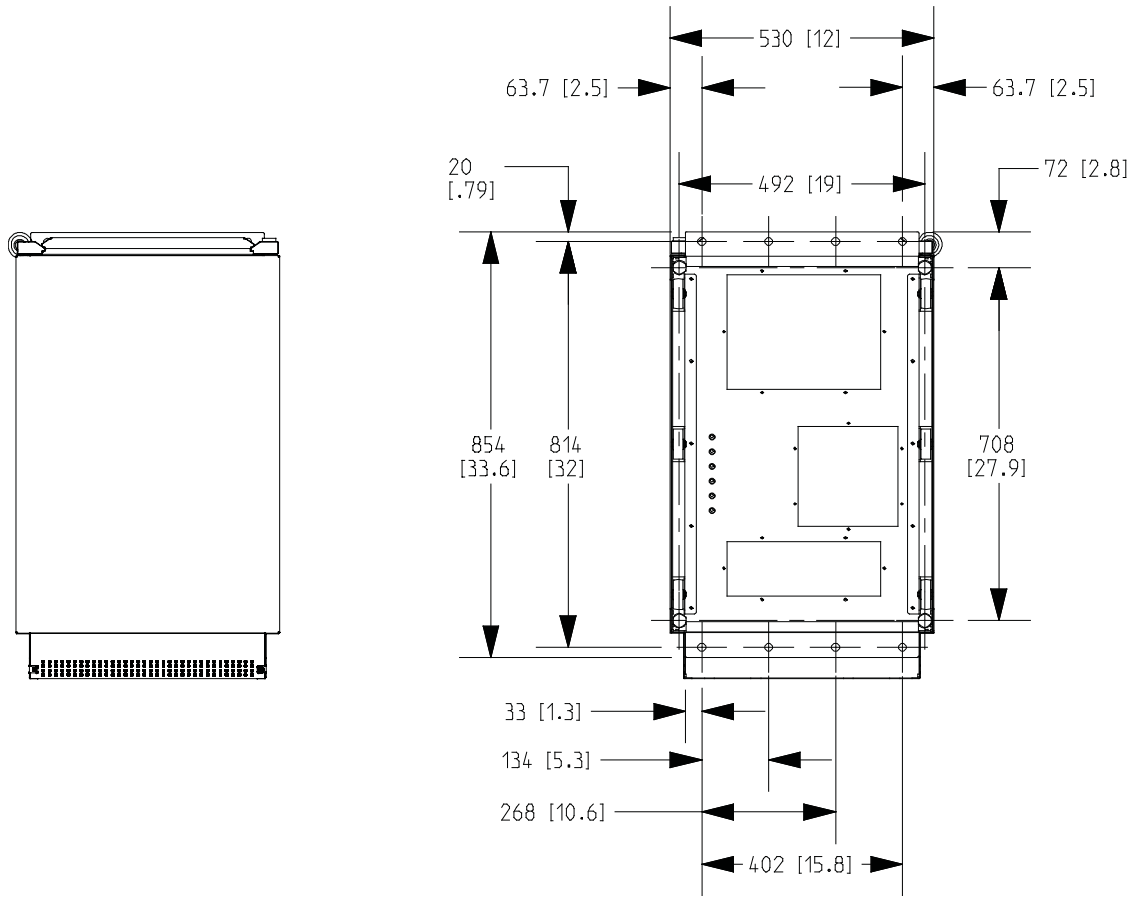

Dimensions are in millimeters [inches]

Figure 3-2. 93E 30IAC-D Dimensions (Top and Bottom Views)

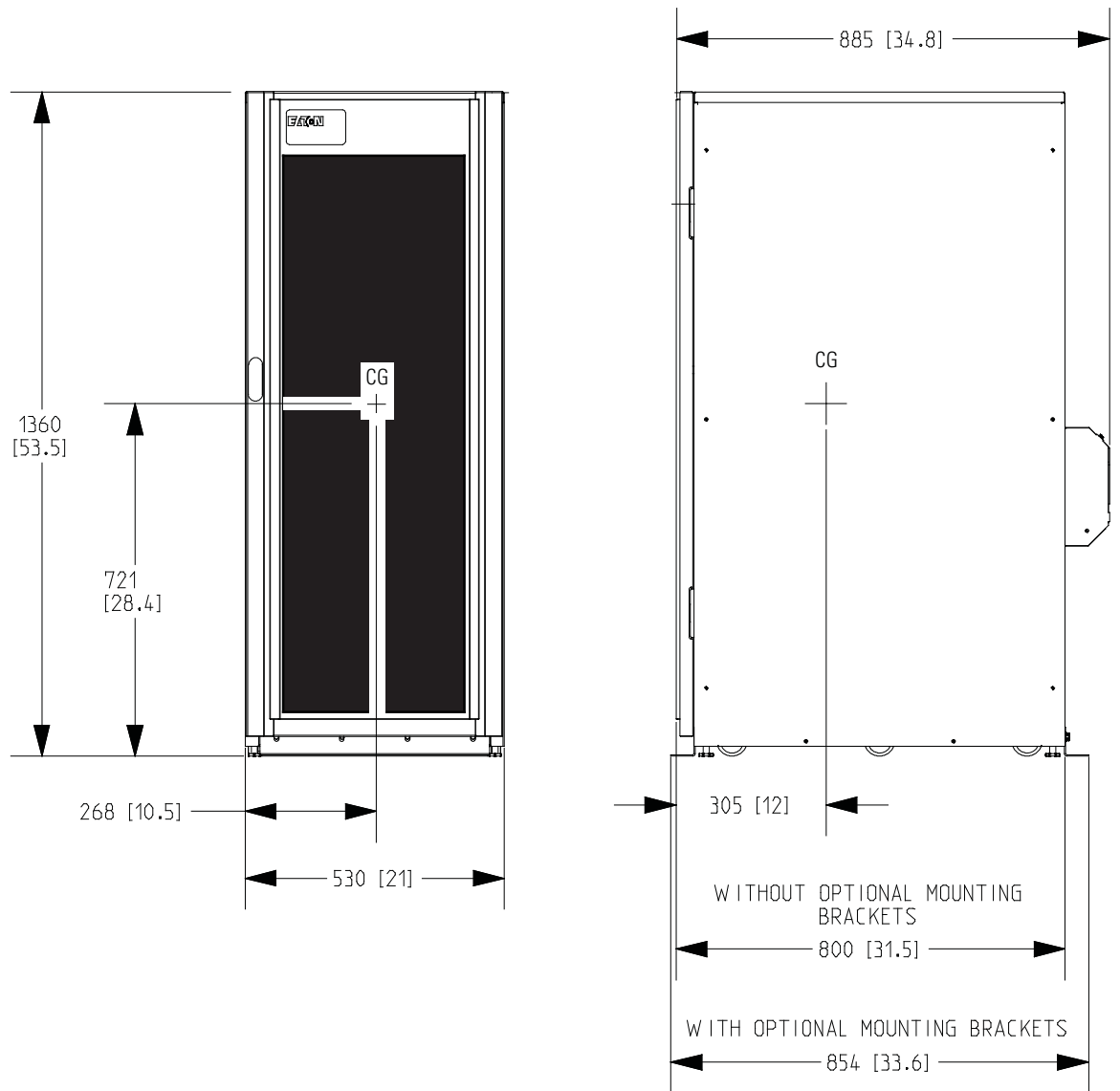

Dimensions are in millimeters [inches]

Figure 3-3. 93E 30IAC-D Center of Gravity

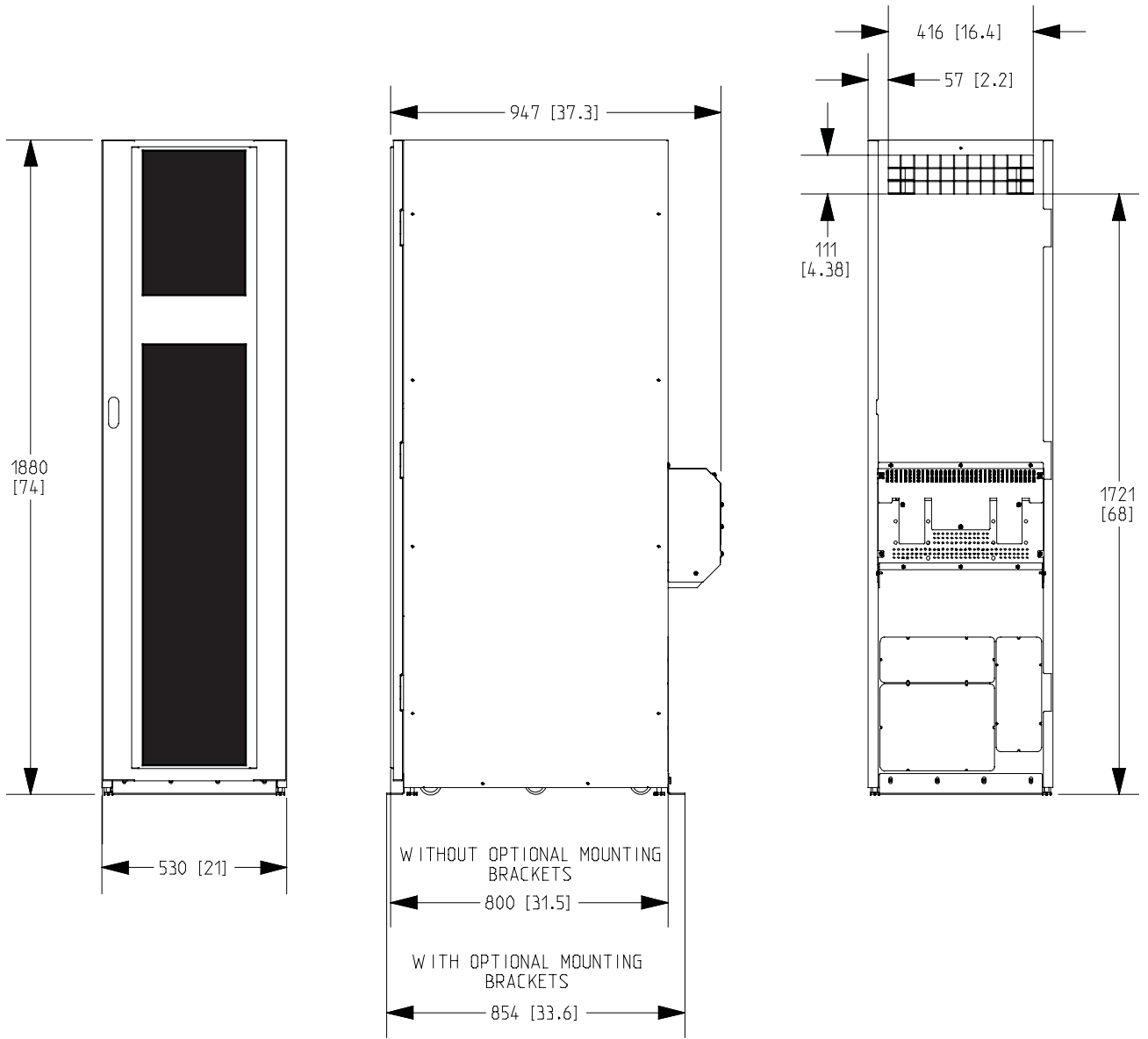

Dimensions are in millimeters [inches]

Figure 3-4. 93E 60IAC-D Cabinet Dimensions (Front, Right Side, and Rear Views)

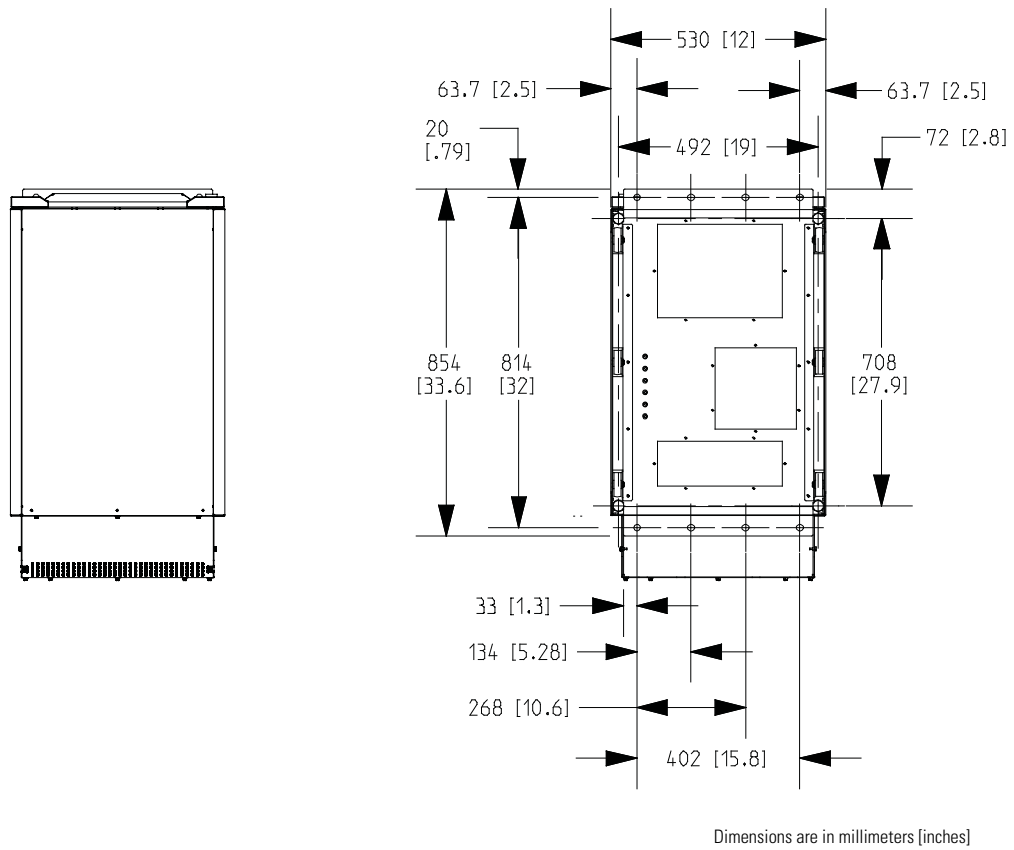
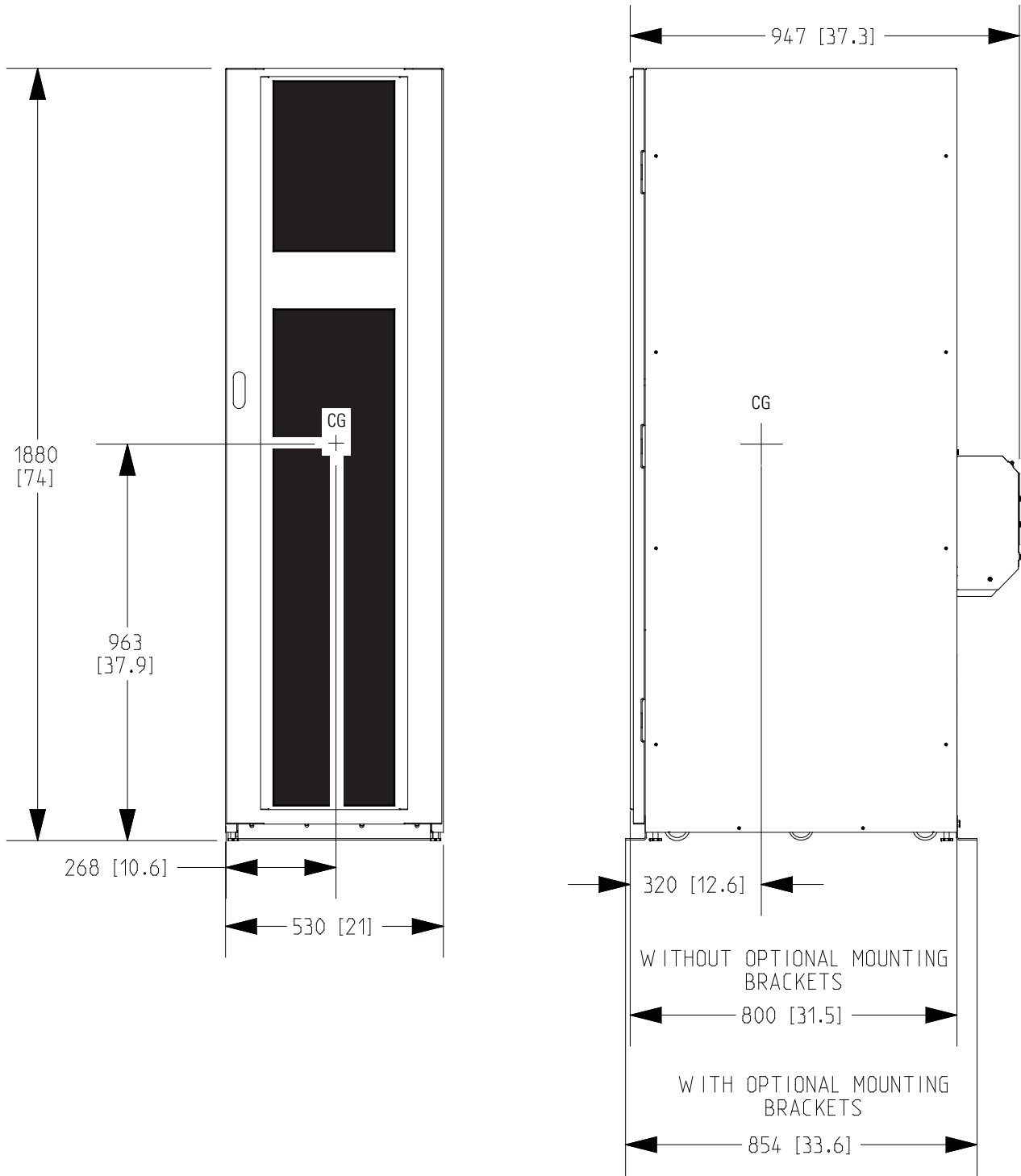

Figure 3-5. 93E 60IAC-D Dimensions (Top and Bottom Views)



Dimensions are in millimeters [inches]

Figure 3-6. 93E 60IAC-D Center of Gravity

3.2.2 IAC-D Power Wiring Preparation

Read and understand the following information while planning and performing the installation:

 **WARNING**

As a result of the connected loads, high leakage current is possible. Connection to earth ground is required for safety and proper product operation. Do not check IAC-D operation by any action that includes removal of the earth (ground) connection with loads attached.

- Refer to national and local electrical codes for acceptable external wiring practices.
- Material and labor for external wiring requirements are to be provided by the customer.
- For external wiring, use copper wire with 90°C rated insulation. Wire sizes listed in Table 3-3 are for copper wiring only. If wire is run in an ambient temperature greater than 30°C (86°F), higher temperature wire and/or larger size wire may be necessary. Wire sizes are based on using the specified breakers.
- Wire ampacities are chosen from Table 310-16 of the National Electrical Code® (NEC®). Specification is for copper wire with a 90°C insulation rating.
- Refer to NEC Article 250 and local codes for proper grounding practices.
- Per NEC Article 300-20(a), all three-phase conductors must be run in the same conduit. Neutral and ground must be run in the same conduit as the phase conductors.
- Phase rotation must be clockwise starting with phase A (rotation A,B,C).
- Conduit is to be sized to accommodate one neutral conductor the same size as the phase conductor and one ground conductor. If two neutral conductors or an oversized neutral conductor are to be installed, size the conduit to accommodate the extra wire or size.
- 225A distribution panels use Cutler-Hammer bolt-on type BAB or QBHW breakers for bolt-on panels. Breakers to be provided by the customer.
- Refer to the appropriate Eaton 93E UPS installation and operation manual listed in paragraph 1.7 for UPS cabinet conduit and terminal specifications and locations.
- The term *line-up-and-match* refers to accessory cabinets that are physically located adjacent to the UPS. The term *standalone* refers to accessory cabinets that are located separate from the UPS.

For external power wiring requirements, including the minimum AWG size of external wiring, see Table 3-3. Wire sizes listed are for copper wiring only.

Table 3-3. External Power Wiring Requirements for the Eaton 93E 30IAC-D and 60IAC-D

| Basic Unit Rating | Units | | Rating 60 Hz | |
|---|----------|---|------------------|------------------|
| | kVA | 30 | 60 | |
| Input/Output Voltage | Volts | 208Y/120 | 208Y/120 | |
| AC Input to IAC-D (3) Phases, (1) Neutral, (1) Ground | A | Maximum Amps | 167 | 334 |
| Minimum Conductor Size (Phase A, B, and C) Number per Phase | | AWG or kcmil [CSA – mm2] (each) | 1/0 [143] (2) | 250 [297] (2) |
| Minimum Conductor Size (Neutral) Number per Phase | | AWG or kcmil [CSA – mm2] (each) | 1/0 [143] (4) | 250 [297] (4) |
| Minimum Conductor Size (Ground) Number per Phase | | AWG or kcmil [CSA – mm2] (each) | #4 [63] (1) | #2 [86] (1) |
| AC Output | | Maximum Amps | 167 | 334 |
| AC Output from Distribution Panel Breakers to the Critical Load | B | Wire branch circuits in accordance with branch circuit breaker manufacturer's ratings and instructions, power cable termination sizes listed in Table 3-5, and national and local electrical codes (input is prewired to the panelboard). Maximum output ratings are to be in accordance with the rating label on the IAC-D. The total combined load is not to exceed the maximum output rating. | | |
| AC Output from Subfeed Breakers to the Critical Load (3) Phases, (1) Neutral, (1) Ground | B | Wire branch circuits in accordance with branch circuit breaker manufacturer's ratings, power cable termination sizes listed in Table 3-5, and national and local electrical codes. Maximum output ratings are to be in accordance with the rating label on the IAC-D. The total combined load is not to exceed the maximum output rating. | | |
| NOTE Callout letters A and B map to Figure 5-1 | | | | |

The power wiring terminals are pressure terminations, UL and CSA rated at 90°C. See Table 3-4 for external input power cable terminations and Table 3-5 for external output power cable terminations.

Figure 4-11 and Figure 4-12 show the IAC-D input power terminal locations and detail.

Table 3-4. External Input Power Cable Terminations for the Eaton 93E 30IAC-D and 60IAC-D

| Terminal Function | kVA Rating | Terminal | Function | Number and Size of Pressure Termination | Tightening Torque | Type and Size Screw |
|-------------------|------------|----------|----------|---|-------------------|---------------------|
| | | | | (AWG or kcmil) | Nm (lb in) | |
| AC Input to IAC-D | 30 | A | Phase A | 2 – #6–250 | 31 (275) | 5/16" Hex |
| | | B | Phase B | 2 – #6–250 | 31 (275) | 5/16" Hex |
| | | C | Phase C | 2 – #6–250 | 31 (275) | 5/16" Hex |
| | | N | Neutral | 4 – #2–600 | 56.5 (500) | 1/2" Hex |
| | | G | Ground | 2 – #14–1/0 | 5.6 (50) | Slotted |
| | 60 | A | Phase A | 2 – #6–250 | 31 (275) | 5/16" Hex |
| | | B | Phase B | 2 – #6–250 | 31 (275) | 5/16" Hex |
| | | C | Phase C | 2 – #6–250 | 31 (275) | 5/16" Hex |
| | | N | Neutral | 4 – #2–600 | 56.5 (500) | 1/2" Hex |
| | | G | Ground | 2 – #14–1/0 | 5.6 (50) | Slotted |

Table 3-5. External Output Power Cable Terminations for the Eaton 93E 30IAC-D and 60IAC-D

| Terminal Function | Breaker Rating | Terminal | Function | Number and Size of Pressure Termination (AWG or kcmil) | Tightening Torque Nm (lb in) | Type and Size Screw |
|--|----------------|----------|----------|--|--|---------------------|
| AC Output from Distribution Panel Breakers to Critical Load | N/A | N | Neutral | 64 – #6–#14 | #6–#8: 2.8 (25) #10–#14: 1.7 (15) | Slotted |
| | | | | 22 – 1/0 | #4–#6: 5.0 (45) #8: 4.5 (40) #10–#14: 4.0 (35) | |
| | N/A | G | Ground | 32 – #6–#14 | #6–#8: 2.8 (25) #10–#14: 1.7 (15) | Slotted |
| | | | | 11 – 1/0 | #4–#6: 5.0 (45) #8: 4.5 (40) #10–#14: 4.0 (35) | |
| AC Output from Subfeed Breakers to Critical Load | "EG" Frame | A | Phase A | 1 – #14–1/0 | 31 (275) | 5/16" Hex |
| | | B | Phase B | 1 – #14–1/0 | 31 (275) | 5/16" Hex |
| | | C | Phase C | 1 – #14–1/0 | 31 (275) | 5/16" Hex |
| | | N | Neutral | 64 – #6–#14 | #6–#8: 2.8 (25) #10–#14: 1.7 (15) | Slotted |
| | | | | 22 – 1/0 | #4–#6: 5.0 (45) #8: 4.5 (40) #10–#14: 4.0 (35) | |
| | | G | Ground | 4 – 1/0–#14 | 5.6 (50) | Slotted |
| AC Output from Subfeed Breakers to Critical Load | "JG" Frame | A | Phase A | 1 – #4–350 | 31 (275) | 5/16" Hex |
| | | B | Phase B | 1 – #4–350 | 31 (275) | 5/16" Hex |
| | | C | Phase C | 1 – #4–350 | 31 (275) | 5/16" Hex |
| | | N | Neutral | 64 – #6–#14 | #6–#8: 2.8 (25) #10–#14: 1.7 (15) | Slotted |
| | | | | 22 – 1/0 | #4–#6: 5.0 (45) #8: 4.5 (40) #10–#14: 4.0 (35) | |
| | | G | Ground | 4 – 1/0–#14 | 5.6 (50) | Slotted |
| NOTE Wire branch circuits in accordance with branch circuit breaker manufacturer's ratings and instructions and national and local electrical codes (output is prewired to the panelboard). | | | | | | |

3.3 Inspecting and Unpacking the IAC-D

The cabinet is shipped bolted to a wooden pallet and covered with outer protective packaging material (see Figure 3-7).

 **NOTE** Startup and operational checks must be performed by an authorized Eaton Customer Service Engineer, or the warranty terms specified on page W-1 become void. This service is offered as part of the sales contract for the UPS. Contact an Eaton service representative in advance (usually a two-week notice is required) to reserve a preferred startup date.

 **WARNING**

The IAC-D is heavy (see Table 3-1). If unpacking and unloading instructions are not closely followed, the cabinet may tip and cause serious injury.

1. Carefully inspect the outer packaging for evidence of damage during transit.
-

 **CAUTION**

Do not install a damaged cabinet. Report any damage to the carrier and contact an Eaton service representative immediately.

 **NOTE** For the following step, verify that the forklift or pallet jack is rated to handle the weight of the cabinet (see Table 3-1).

2. Use a forklift or pallet jack to move the packaged cabinet to the installation site, or as close as possible, before unpacking. If possible, move the cabinet using the pallet. Insert the forklift or pallet jack forks between the supports on the bottom of the pallet (see Figure 3-3 or Figure 3-6 for the IAC-D cabinet center of gravity measurements).
-

 **CAUTION**

Do not tilt the IAC-D more than 10° from vertical or the cabinet may tip over.

3. Set the pallet on a firm, level surface, allowing a minimum clearance of 3m (10 ft) on each side for removing the cabinet from the pallet.
 4. Remove the protective packaging material from the cabinet and recycle in a responsible manner. Retain the parts kit box packed at the top of the cabinet.
 5. Inspect the contents for any evidence of physical damage, and compare each item with the Bill of Lading. If damage has occurred or shortages are evident, contact an Eaton service representative immediately to determine the extent of the damage and its impact on further installation.
-

 **NOTE** While waiting for installation, protect the unpacked cabinet from moisture, dust, and other harmful contaminants. Failure to store and protect the IAC-D properly may void your warranty.

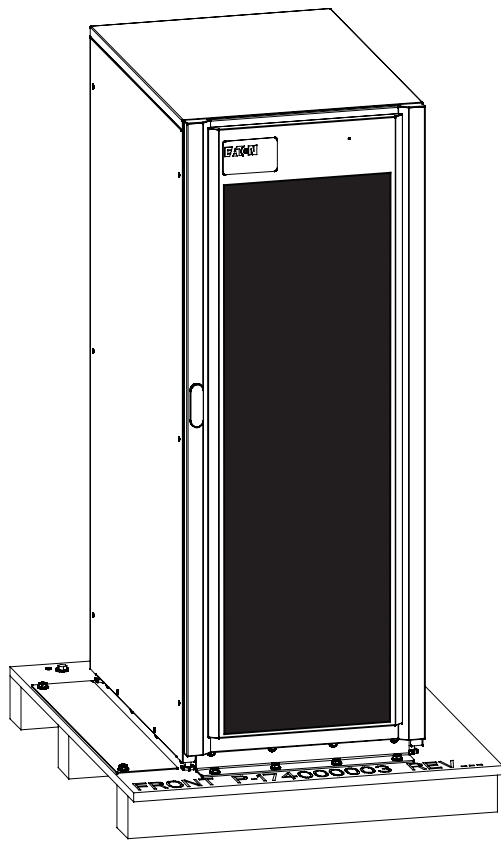

93E 30IAC-D

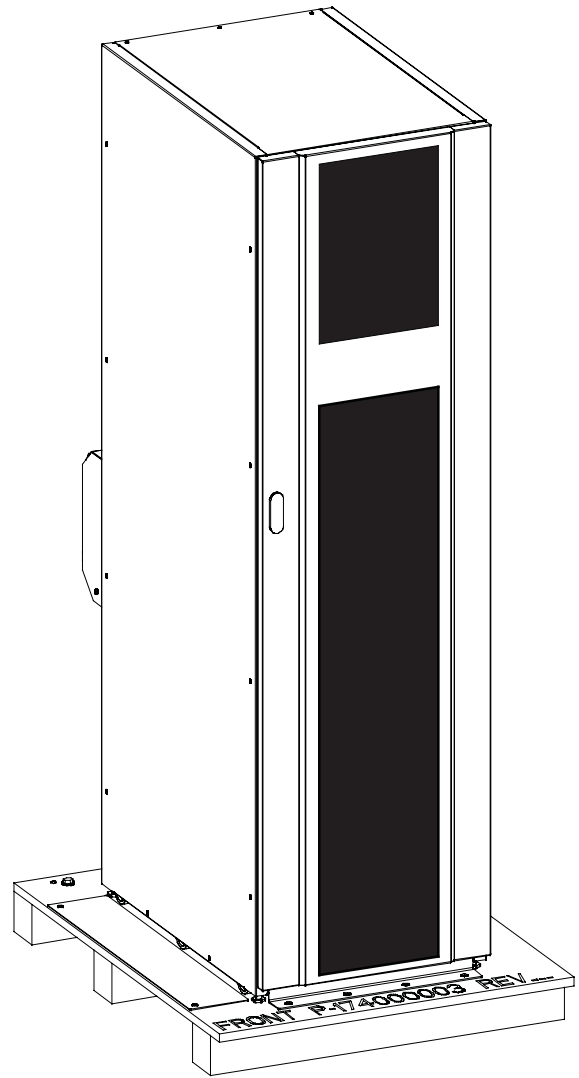

93E 60IAC-D

Figure 3-7. Eaton 93E 30IAC-D and Eaton 93E 60IAC-D as Shipped on a Wooden Pallet

This page intentionally left blank.

Chapter 4 Installation

4.1 Preliminary Installation Information

 WARNING

Installation should be performed only by qualified personnel.

When installing the Eaton® 93E Integrated Accessory Cabinet-Distribution (IAC-D):

- See Chapter 3 for cabinet dimensions, equipment weight, wiring and terminal data, and installation notes.
- Do not tilt the IAC-D more than 10° vertical or the cabinet may tip over.

4.2 Unloading the IAC-D Cabinet from the Pallet

The IAC-D is bolted to a wooden pallet supported by wood skids.

 WARNING

The IAC-D is heavy (see Table 3-1). If unpacking and unloading instructions are not closely followed, the cabinet may tip and cause serious injury.

 CAUTION

- Do not tilt the IAC-D more than 10° from vertical or the cabinet may tip over.
 - Lift the cabinets only with a forklift or pallet jack or damage may occur.
 - Verify that a minimum of 10 feet behind the IAC-D is unobstructed for unloading the IAC-D.
 - The unloading floor must be smooth, with no cracks or large seams to prevent a smooth roll-off of the cabinet.
-

NOTE 1 The IAC-D uses inline wheels, not swivel casters. When moving the IAC-D, move the cabinet in straight lines as much as possible, minimizing turns.



NOTE 2 Before unloading the IAC-D, verify that the forklift or pallet jack is rated to handle the weight of the cabinet (see Table 3-1).

4.2.1 Unloading the 30IAC-D

To remove the pallet:

1. If not already completed, use a forklift or pallet jack to move the IAC-D to the installation area, or as close as possible, before unloading from the pallet. Insert the forklift or pallet jack forks between the supports on the bottom of the pallet (see Figure 3-3 for the IAC-D cabinet center of gravity measurements).
2. Open the front door (see Figure 4-1) by lifting the latch from the bottom and turning to the right (counterclockwise), then swing the door open.
3. If the leveling feet are not fully retracted, turn all four leveling feet until they are retracted into the cabinet.

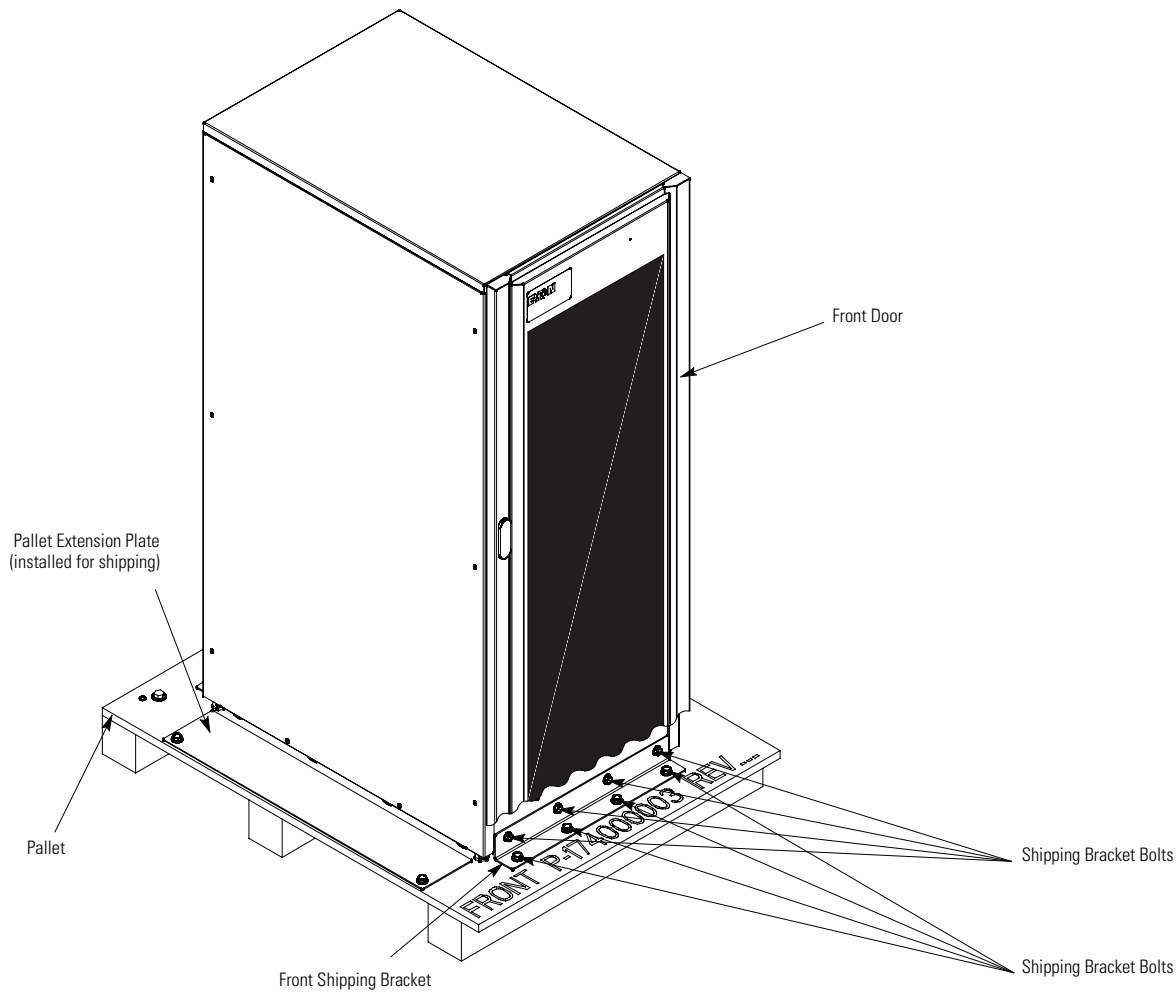

Figure 4-1. Removing the Front Shipping Bracket – 93E 30IAC-D

4. Remove four bolts securing the front shipping bracket to the cabinet and four bolts securing the bracket to the pallet (see Figure 4-1). Remove the front shipping bracket. If installing the cabinet permanently, retain the shipping bracket and securing hardware for later use.
5. Remove four bolts securing the rear shipping bracket to the cabinet and four bolts securing the bracket to the pallet (see Figure 4-2). Remove the rear shipping bracket. If installing the cabinet permanently, retain the shipping bracket and securing hardware for later use.
6. Close the door and secure the latch before rolling the cabinet from the pallet.
7. Remove three bolts securing the removable skid (see Figure 4-2).
8. Remove two bolts securing the pallet extension plate to the pallet and remove the plate (see Figure 4-1).
9. Install the pallet extension plate onto the rear of the pallet using the retained bolts (see Figure 4-3). Use the mounting holes provided in the pallet (see Figure 4-2).
10. If necessary, use a forklift or pallet jack between the supports on the bottom of the pallet to lift the pallet by approximately 3 mm (1/8") and remove the skid (see Figure 4-2).

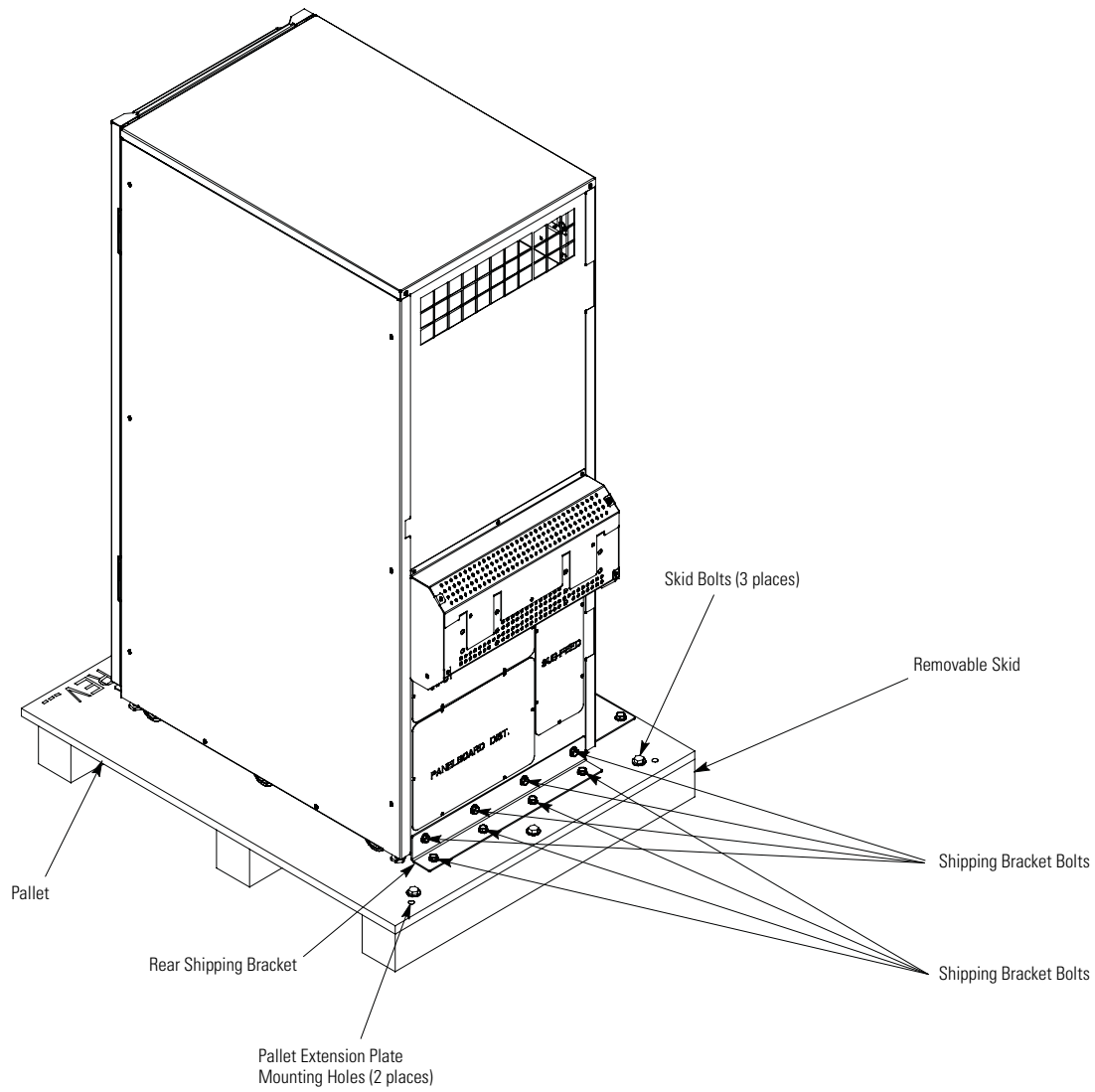

Figure 4-2. Removing the Rear Shipping Bracket – 93E 30IAC-D

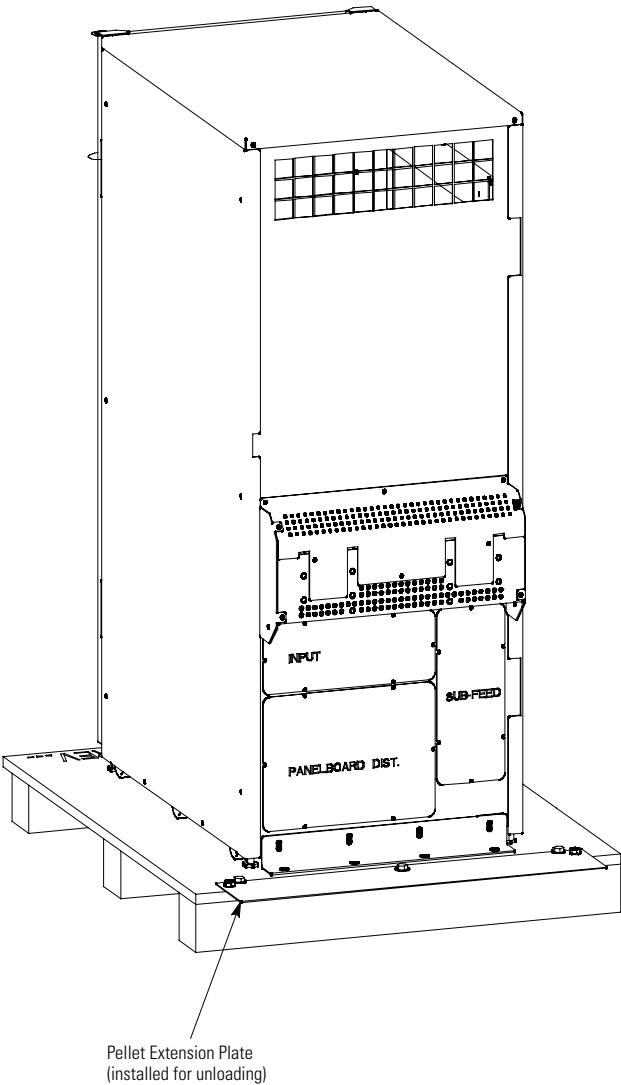

Figure 4-3. Installing the Pellet Extension Plate – 93E 30IAC-D

NOTE 1 In Step 11 the pallet tilts and acts as a ramp once the cabinet is rolled beyond the center of the pallet.



NOTE 2 The pallet extension plate may bend when the pallet is tilted, but will continue to provide a smooth transition to the floor.

WARNING

Do not stand directly in front of or behind the pallet when unloading the cabinet. If unloading instructions are not closely followed, the cabinet may cause serious injury.

11. Slowly roll the cabinet toward the rear of the pallet. Once the pallet tilts, continue rolling the cabinet down the pallet extension plate until the cabinet is clear of the pallet.
 12. Roll the IAC-D to the final installation location to the left of the UPS cabinet. Verify that the cabinet doors are flush with each other.
 13. If installing the cabinet permanently, retain the shipping brackets and hardware; otherwise, recycle the pallet and shipping brackets in a responsible manner.
-



NOTE Use leveling feet only to level and lock the cabinet in place. Using the leveling feet to raise the cabinet may result in serious injury to personnel or damage to the cabinet.

14. Secure the IAC-D in position by lowering the leveling feet until the cabinet is not resting on the inline wheels and the cabinet is level.
-

WARNING

Failure to anchor the cabinet could lead to injury or death. To reduce this risk, the IAC-D, must be secured to the building floor or to an adjacent 93E system cabinet.

15. If installing the cabinet permanently, continue to Step 16; otherwise, skip to Step 18.
16. Using the retained hardware (removed in Steps 4 and 5), reinstall the shipping brackets to the front and rear of the IAC-D with the angle facing outward (see Figure 4-1 and Figure 4-2).
17. Secure the cabinet to the floor with customer-supplied hardware. Skip to Step 19.
18. Install cabinet bracket between the IAC-D and the UPS (see Figure 4-4).
19. Skip to paragraph 4.3.

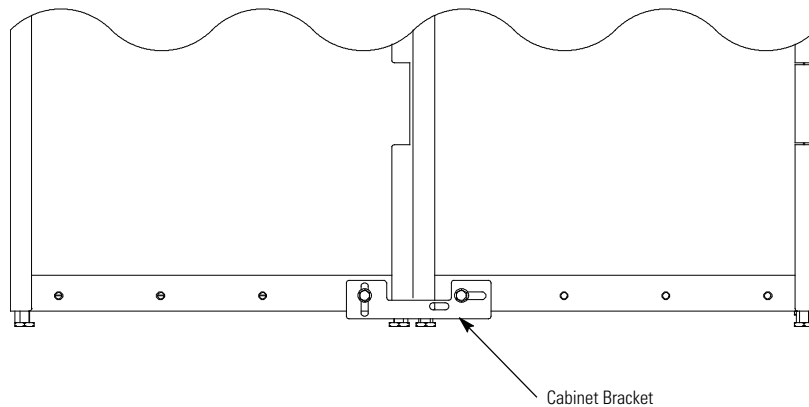

Figure 4-4. Cabinet Bracket

4.2.2 Unloading the 60IAC-D

To remove the pallet:

1. If not already completed, use a forklift or pallet jack to move the IAC-D to the installation area, or as close as possible, before unloading from the pallet. Insert the forklift or pallet jack forks between the supports on the bottom of the pallet (see Figure 3-6 for the IAC-D cabinet center of gravity measurements).
2. Open the front door by lifting the latch from the bottom and turning to the right (counterclockwise), then swing the door open.
3. If the leveling feet are not fully retracted, turn all four leveling feet until they are retracted into the cabinet.
4. Remove four bolts securing the front shipping bracket to the cabinet and four bolts securing the bracket to the pallet (see Figure 4-5). Remove the front shipping bracket. If installing the cabinet permanently, retain the shipping bracket and securing hardware for later use.
5. Remove four bolts securing the rear shipping bracket to the cabinet and four bolts securing the bracket to the pallet (see Figure 4-6). Remove the rear shipping bracket. If installing the cabinet permanently, retain the shipping bracket and securing hardware for later use.
6. Close the door and secure the latch before rolling the cabinet from the pallet.
7. Remove three bolts securing the removable skid (see Figure 4-6).
8. Remove two bolts securing the pallet extension plate to the pallet and remove the plate (see Figure 4-5).
9. Install the pallet extension plate onto the rear of the pallet using the retained bolts (see Figure 4-7). Use the mounting holes provided in the pallet (see Figure 4-6).

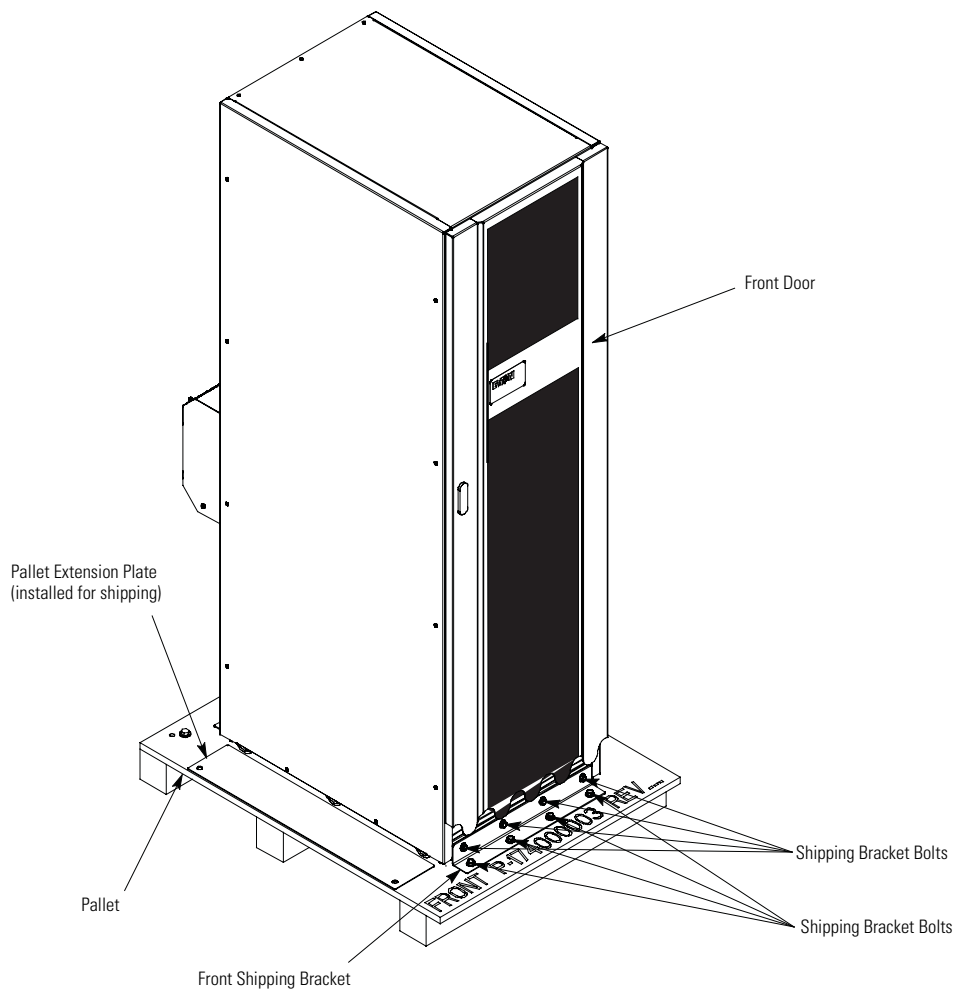

Figure 4-5. Removing the Front Shipping Bracket – 93E 60IAC-D

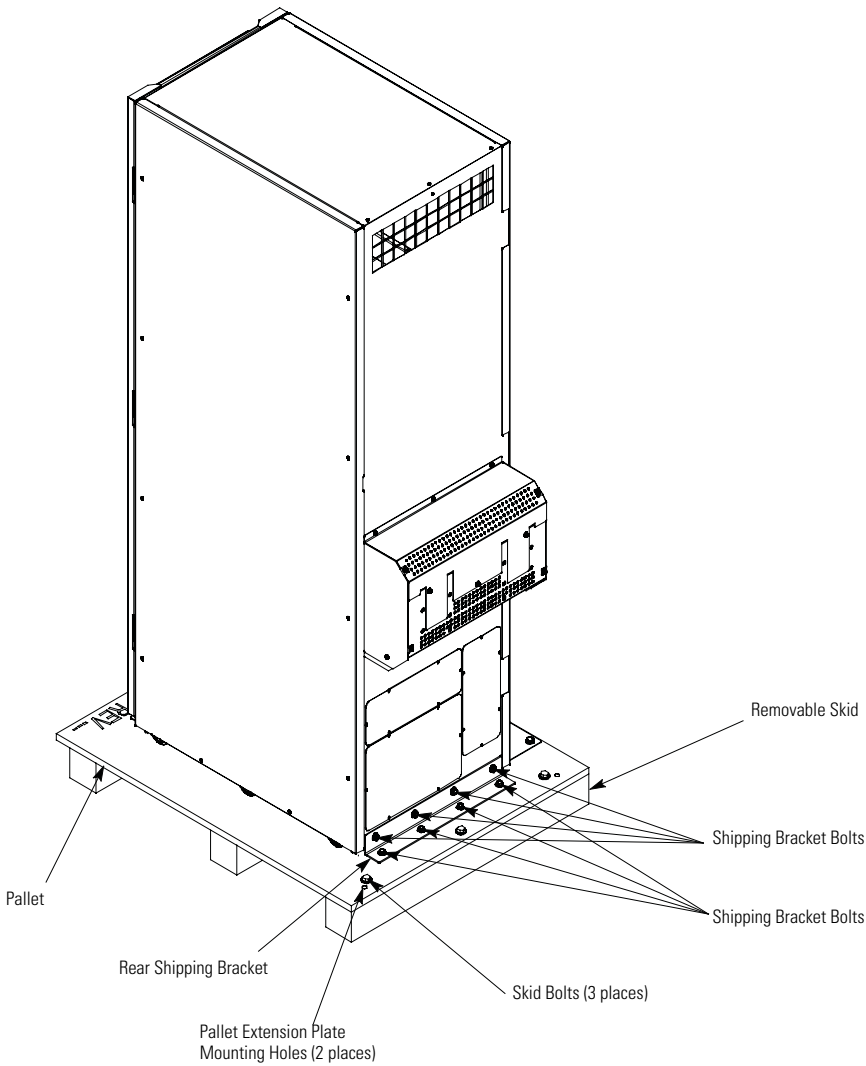

Figure 4-6. Removing the Rear Shipping Bracket – 93E 60IAC-D

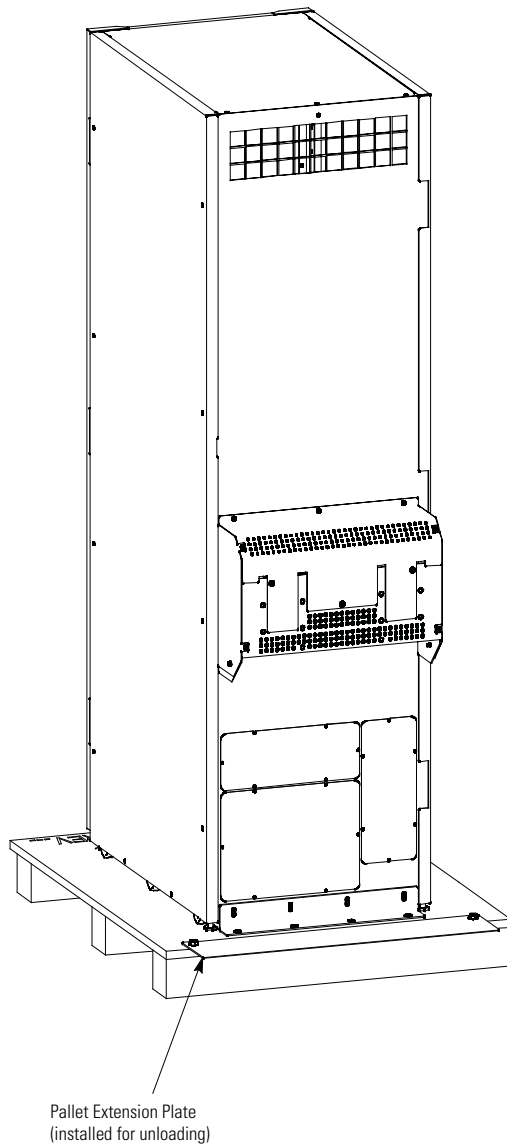

Figure 4-7. Installing the Pallet Extension Plate – 93E 60IAC-D

10. If necessary, use a forklift or pallet jack between the supports on the bottom of the pallet to lift the pallet by approximately 3 mm (1/8") and remove the skid (see Figure 4-6).

NOTE 1 In Step 11 the pallet tilts and acts as a ramp once the cabinet is rolled beyond the center of the pallet.



NOTE 2 The pallet extension plate may bend when the pallet is tilted, but will continue to provide a smooth transition to the floor.

 **WARNING**

Do not stand directly in front of or behind the pallet when unloading the cabinet. If unloading instructions are not closely followed, the cabinet may cause serious injury.

11. Slowly roll the cabinet toward the rear of the pallet. Once the pallet tilts, continue rolling the cabinet down the pallet extension plate until the cabinet is clear of the pallet.
12. Roll the IAC-D to the final installation location to the left of the UPS cabinet. Verify that the doors are flush with each other.
13. If installing the cabinet permanently, retain the shipping brackets and hardware; otherwise, recycle the pallet and shipping brackets in a responsible manner.



NOTE Use leveling feet only to level and lock the cabinet in place. Using the leveling feet to raise the cabinet may result in serious injury to personnel or damage to the cabinet.

14. Secure the IAC-D in position by lowering the leveling feet until the cabinet is not resting on the inline wheels and the cabinet is level.

 **WARNING**

Failure to anchor the cabinet could lead to injury or death. To reduce this risk, the IAC-D, must be secured to the building floor or to an adjacent 93E system cabinet.

15. If installing the cabinet permanently, continue to Step 16; otherwise, skip to Step 18.
16. Using the retained hardware (removed in Steps 4 and 5), reinstall the shipping brackets to the front and rear of the IAC-D with the angle facing outward (see Figure 4-5 and Figure 4-6).
17. Secure the cabinet to the floor with customer-supplied hardware. Skip to Step 19.
18. Install cabinet bracket between the IAC-D and the adjacent UPS (see Figure 4-4).
19. Continue to paragraph 4.3.

4.3 Installing the Power Terminal Cover Base

NOTE Wiring can be installed using conduit between cabinets or by routing wiring through the power terminal cover base wiring channels.

To install the power terminal cover base:

1. Locate the terminal cover base (see Figure 4-8) from the parts kit.
2. If installing wiring using conduit, continue to Step 3; otherwise, skip to Step 4.
3. Punch or drill holes in the bottom of the power terminal cover base (see Figure 4-8 and Figure 4-9) for the AC input conduit.
4. Using the hardware provided, install the terminal cover base to the back panel of the IAC-D using the existing cabinet screw holes (see Figure 4-9).
5. Continue to paragraph 4.4 on page 4-13.

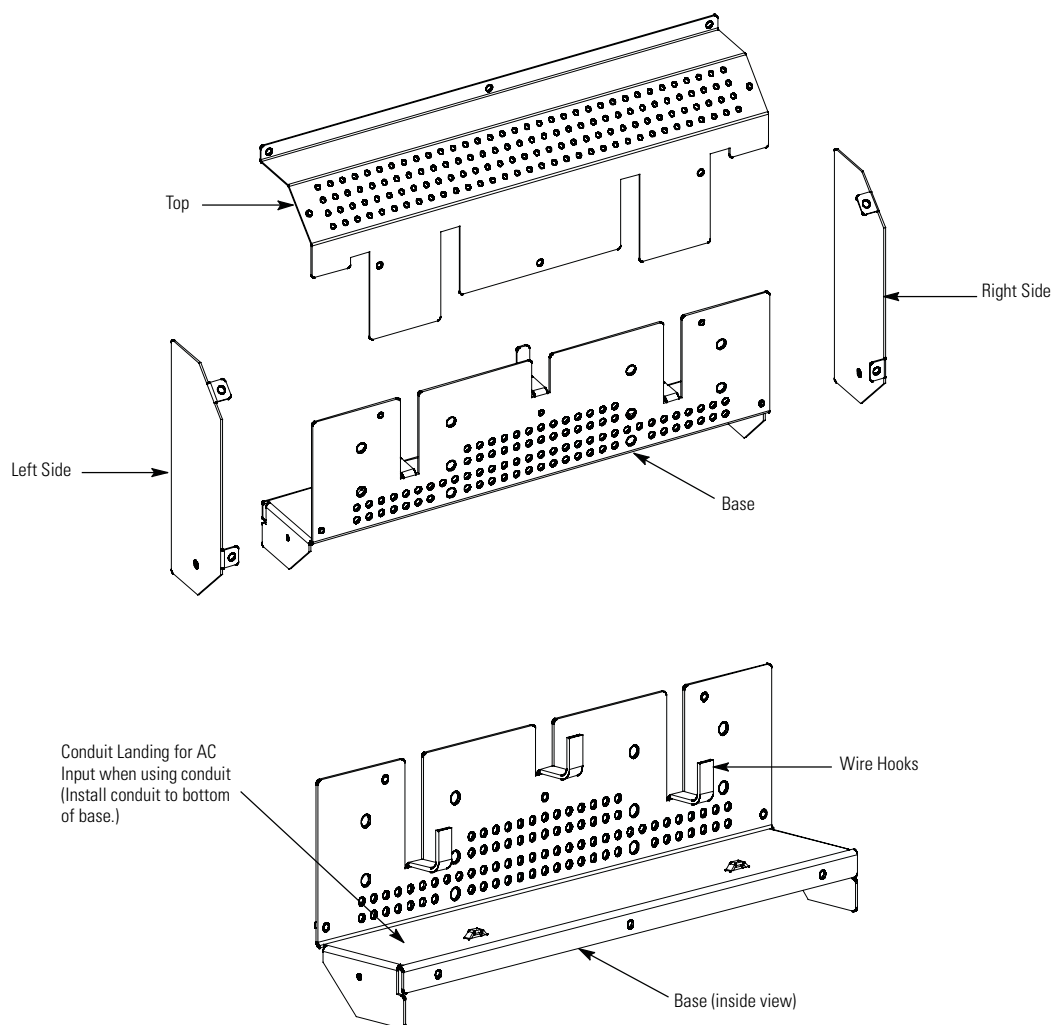

NOTE Do not install the Power Terminal Cover Left and/or Right Side covers if wiring adjacent cabinets using the power terminal base wiring channel.

Figure 4-8. IAC-D Power Terminal Cover Parts

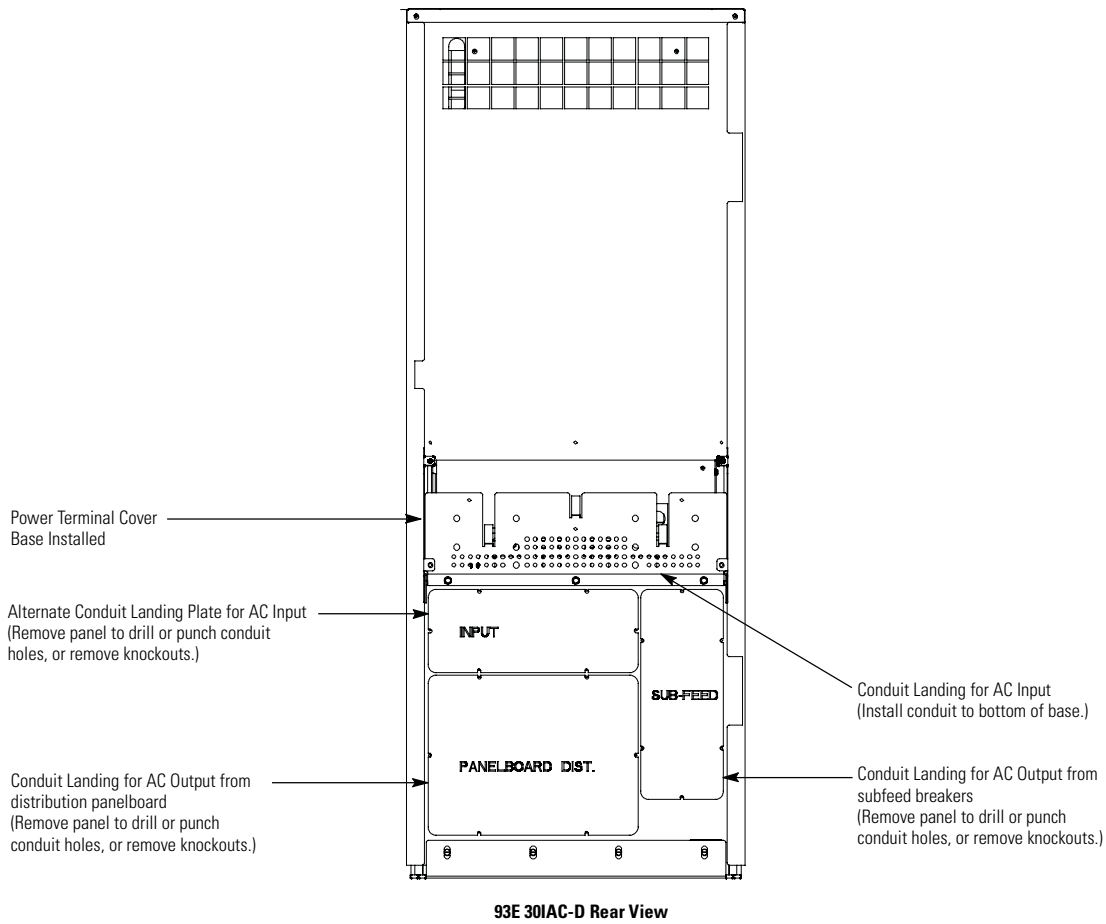

NOTE The 93E 30IAC-D is shown. The 93E 60IAC-D terminal cover base installation and conduit landing plate locations are the same.

Figure 4-9. IAC-D Power Terminal Cover Base Installation and Rear Conduit Landing Wire Entry Locations

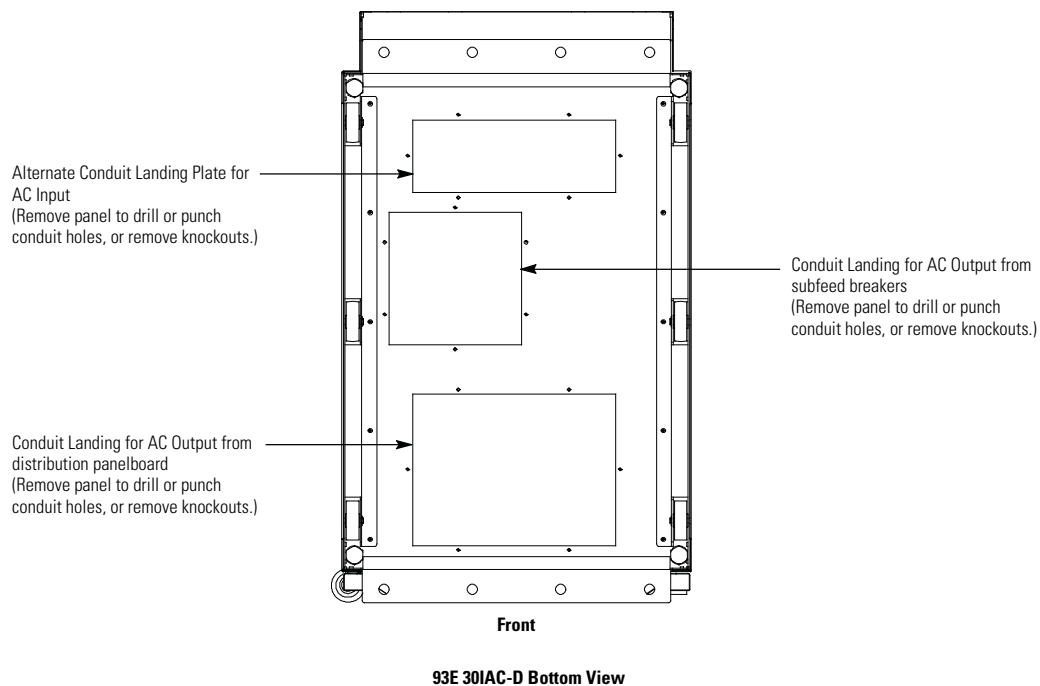

NOTE The 93E 30IAC-D is shown. The 93E 60IAC-D conduit landing plate locations are the same.

Figure 4-10. Bottom Conduit Landing Wire Entry Locations

4.4 Installing IAC-D External Power Wiring

NOTE 1 Wiring can be installed using conduit between cabinets or by routing wiring through the power terminal cover base wiring channels.

NOTE 2 Remove the IAC-D conduit landing plates to drill or punch conduit holes, or remove knockouts in the conduit plate (see Figure 4-9 or Figure 4-10).

NOTE 3 To aid in securing wiring and obtaining correct torque values, use a wire ferrule on small gauge wiring when installing to terminal lugs.

To install wiring to connections:

1. If installing wiring using conduit, continue to Step 2; if using the power terminal cover base channels, skip to Step 11.
2. Identify all conduit requirements and mark their location on the IAC-D input conduit landing plate. Remove the conduit plate and drill or punch conduit holes, or remove knockouts in the conduit plate. Reinstall the conduit plate.
3. Punch or drill holes in the bottom of the power terminal cover base on the UPS cabinet for the AC output conduit. Refer to the applicable Eaton 93E UPS installation and operation manual listed in paragraph 1.7 for UPS cabinet conduit landing location.
4. Install conduit between the IAC-D and the UPS cabinet, IAC-T, IAC-B, or IAC-TB.

5. Route the IAC-D input cables (phase A, B, and C, Neutral, and Ground) through the conduit on the back of the IAC-D to the UPS, IAC-T, IAC-B, or IAC-TB output terminals. See Figure 4-11 or Figure 4-13 for IAC-D wiring access information and terminal locations. See paragraph 3.2.2, Table 3-3, and Table 3-4 for IAC-D wiring and termination requirements. Refer to the applicable Eaton 93E UPS or 93E Integrated Accessory Cabinet-Tie and Bypass Installation and Operation manual listed in paragraph 1.7 for their respective terminal locations and termination requirements.
6. Connect phase A, B, and C, Neutral, and Ground power wiring to the corresponding terminals on IAC-D. See Figure 4-12.
7. Connect phase A, B, and C, Neutral, and Ground power wiring to the corresponding terminals on the UPS, IAC-T, IAC-B, or IAC-TB.
8. Install the power terminal cover top using the provided hardware (see Figure 4-14).
9. Install the power terminal cover right and left sides using the provided hardware (see Figure 4-14).
10. Proceed to Step 21.
11. Route the IAC-D input cables (phase A, B, and C, Neutral, and Ground) through the power terminal cover base wiring channels (see Figure 4-15) from the IAC-D to the UPS, IAC-T, IAC-B, or IAC-TB output terminals. See Figure 4-11 or Figure 4-13 for IAC-D wiring access information and terminal locations. See paragraph 3.2.2, Table 3-3, and Table 3-4 for IAC-D wiring and termination requirements. Refer to the applicable Eaton 93E UPS or 93E Integrated Accessory Cabinet-Tie and Bypass Installation and Operation manual listed in paragraph 1.7 for their respective terminal locations and termination requirements.
12. Connect phase A, B, and C, Neutral, and Ground power wiring to the corresponding terminals on IAC-D. See Figure 4-12.
13. Connect phase A, B, and C, Neutral, and Ground power wiring to the corresponding terminals on the UPS, IAC-T, IAC-B, or IAC-TB.
14. Secure the power cables to the power terminal cover base using wire ties after all electrical connections have been completed.
15. Install the power terminal cover tops using the provided hardware (see Figure 4-16).
16. Install the IAC-D left side power terminal cover and the UPS right side power terminal cover using the provided hardware (see Figure 4-16).
17. Install the splice cover using the provided hardware (see Figure 4-16).
18. If not already open, open the front door by lifting the latch from the bottom and turning to the right (counterclockwise) and swing the door open (see Figure 4-1 or Figure 4-5).
19. Loosen the screws securing the inside distribution panel door and swing the door open.
20. Loosen the screws securing the inside terminal cover plate and remove the plate.
21. Install customer-supplied branch circuit breakers into the distribution panel (see Figure 4-17). Use Cutler-Hammer bolt-on type BAB or QBHW breakers for bolt-on panels, or plug-on type HQP or QPHW breakers for plug-on panels.

**NOTE**

When wiring branch circuits, begin adding conduits at the back of the bottom or top of the rear conduit landing plates to simplify future circuit additions.

22. Route output cables to the branch circuit breakers and wire the branch circuits according to the branch circuit breaker manufacturer's ratings and instructions, and national and local electrical codes (input is prewired to the panelboard). See Figure 4-17 for neutral and ground terminal locations, Table 3-3 for wiring requirements, and Table 3-5 for termination requirements.
23. If wiring an IAC-D with subfeed breakers, continue to Step 24; otherwise, skip to Step 26.

NOTE  When wiring subfeed branch circuits, begin adding conduits at the back of the bottom or top of the rear conduit landing plates to simplify future circuit additions.

24. Route output cables from subfeed breakers to the critical load. See Figure 4-17 for neutral and ground terminal locations, Table 3-3 for wiring requirements and Table 3-5 for termination requirements.
25. Connect phase A, B, and C, Neutral, and Ground power wiring to the subfeed breakers (see Figure 4-18) and the critical load. See Figure 4-17 for neutral and ground terminal locations, Table 3-3 for wiring requirements, and Table 3-5 for termination requirements.
26. Reinstall the inside terminal cover plate removed in Step 20.
27. Close the inside door and secure with screws.
28. Close the outside door and secure the latch.
29. After the IAC-D is installed and wired, return to the applicable Eaton 93E UPS installation and operation manual listed in paragraph 1.7 to complete the UPS wiring.

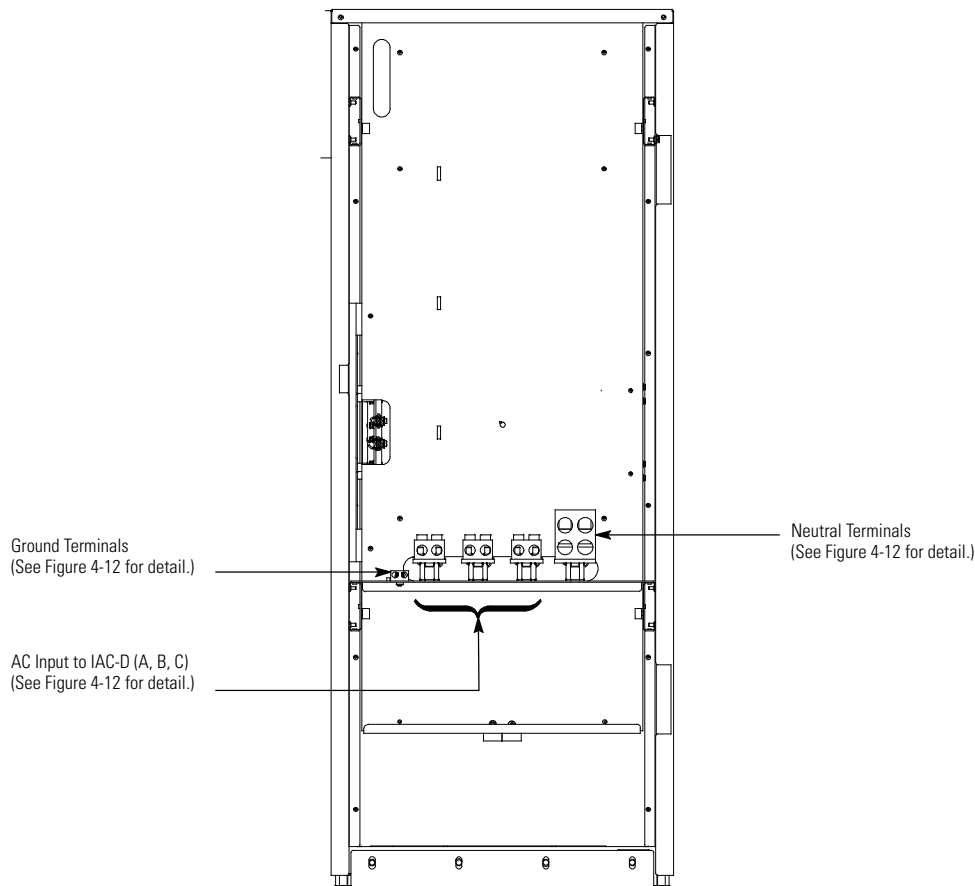

Figure 4-11. Input Power Terminal Locations – 93E 30IAC-D

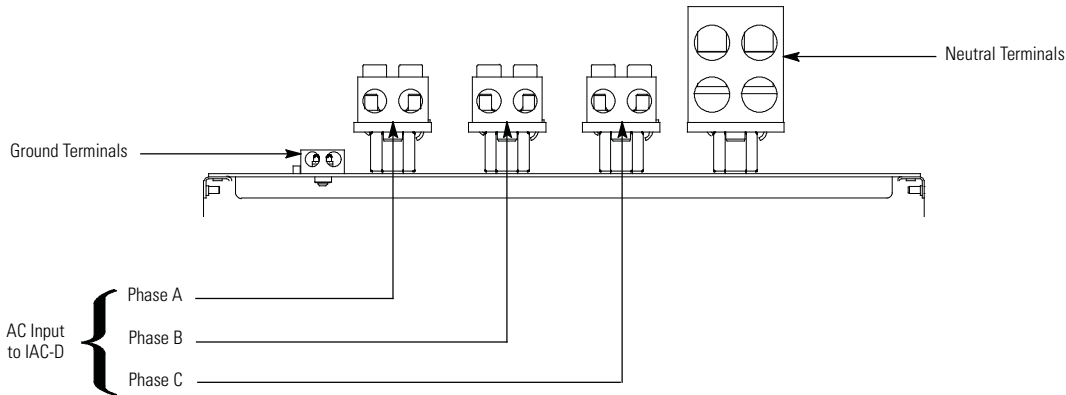

Figure 4-12. Input Power Terminal Detail – 93E 30IAC-D and 93E 60IAC-D

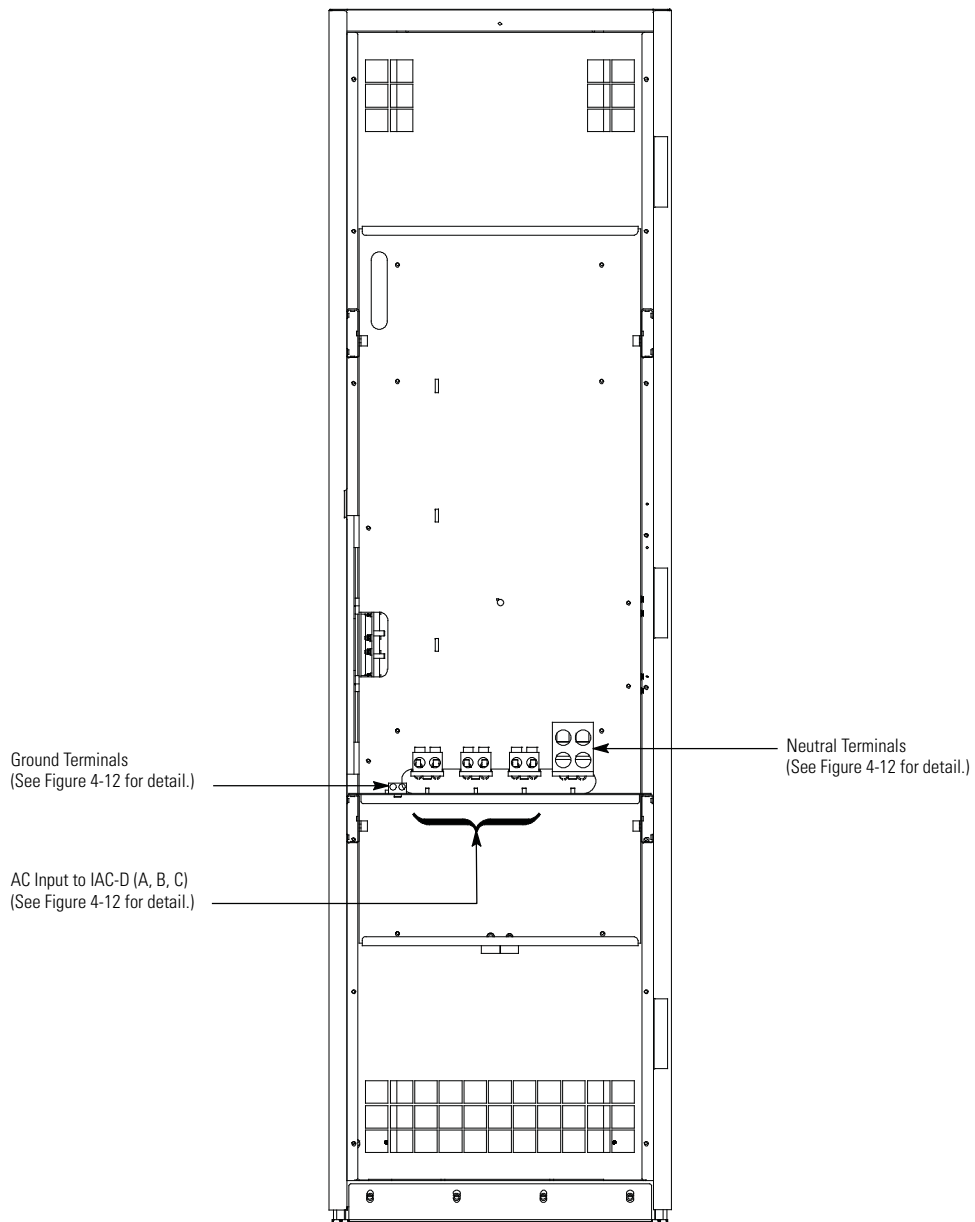
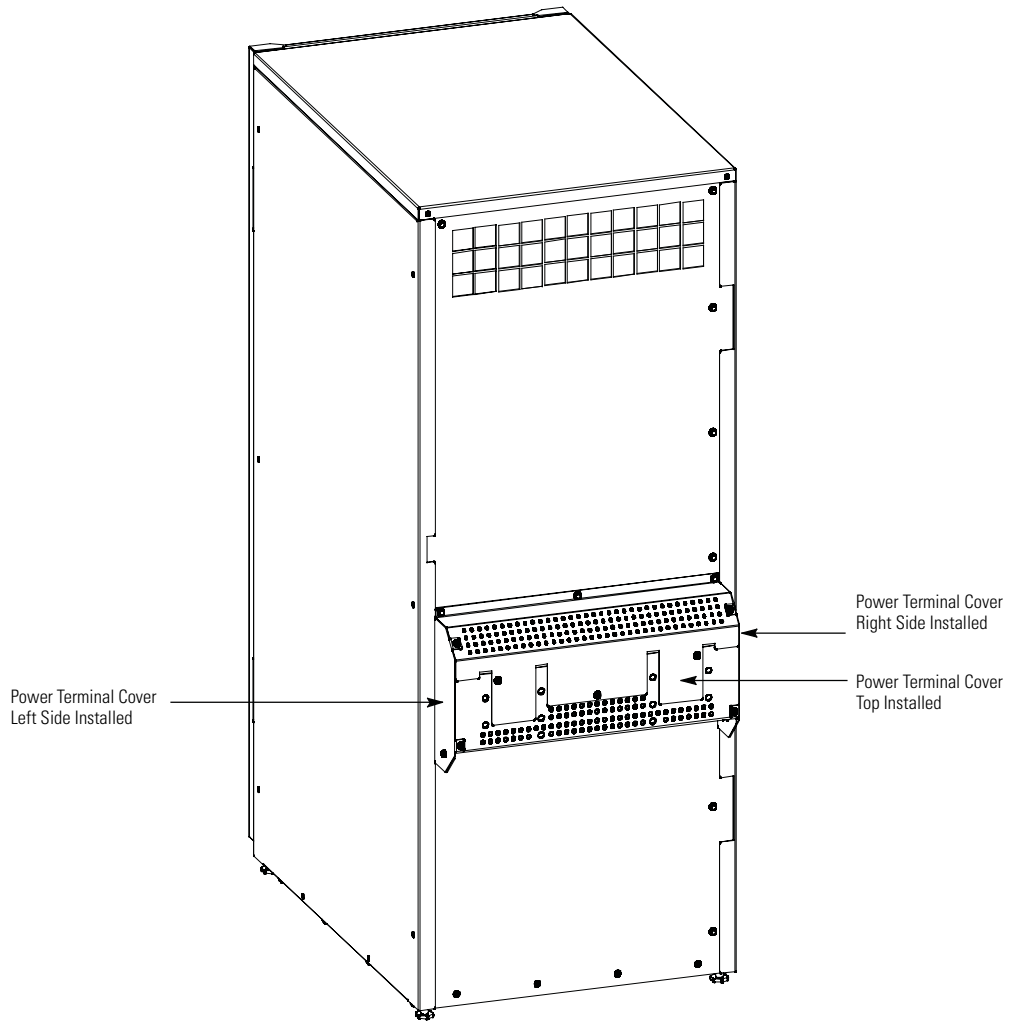

Figure 4-13. Input Power Terminal Locations – 93E 60IAC-D



NOTE 1 The 93E 30IAC-D is shown. The 93E 60IAC-D installation is the same.

NOTE 2 Do not install the Power Terminal Cover Left and/or Right Side covers if wiring adjacent cabinets using the power terminal base wiring channel.

Figure 4-14. IAC-D Power Terminal Cover Installation

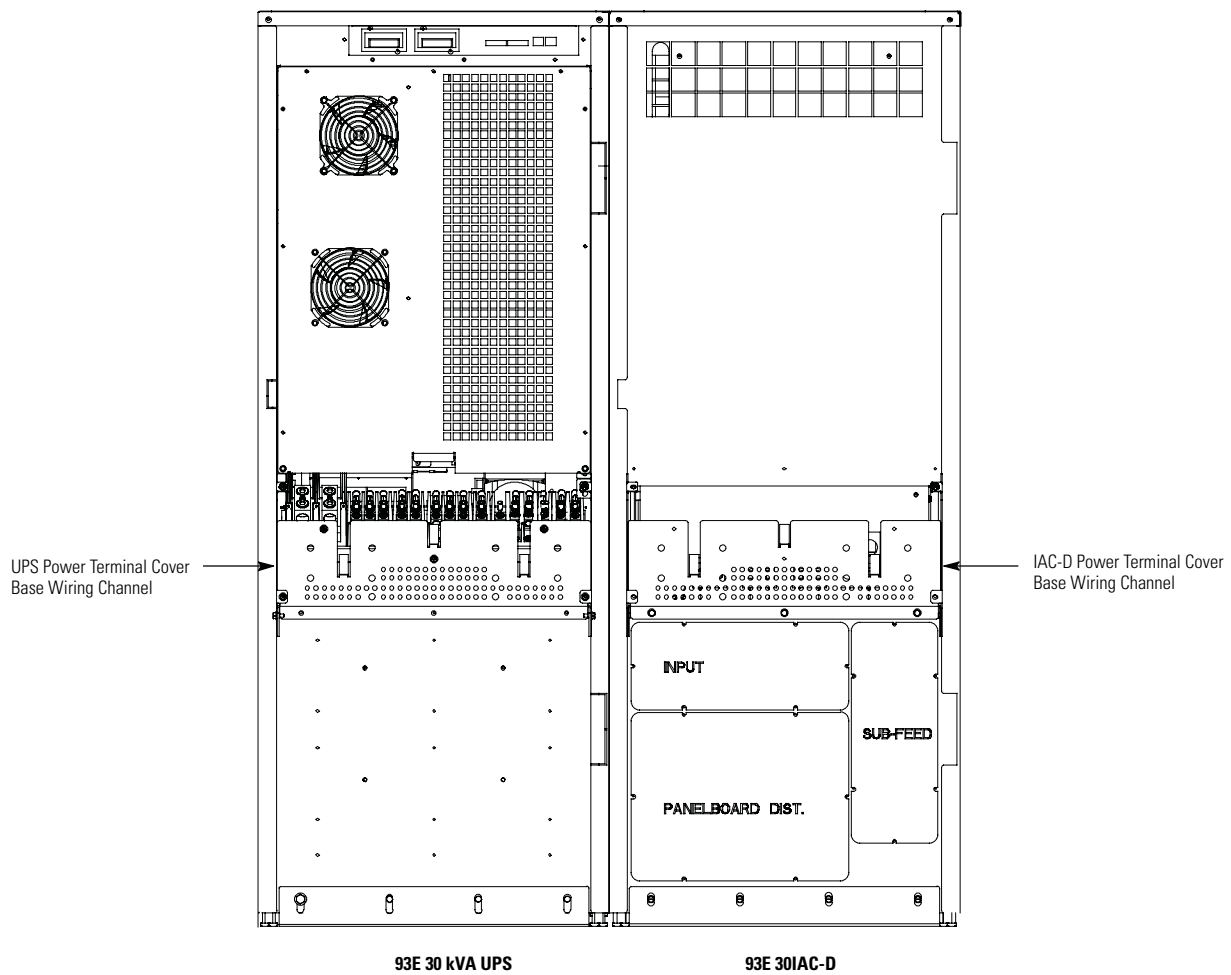

NOTE 1 The 93E 30IAC-D and 93E 30 kVA UPS are shown. The 93E 60IAC-D and 93E 60 kVA UPS installation is the same.

NOTE 2 The UPS and IAC-D are shown adjacent, but other installed accessory cabinets may be adjacent in large systems with multiple cabinets. However, the power terminal base wiring channels are the same.

Figure 4-15. IAC-D and UPS Power Terminal Cover Base Wiring Channel

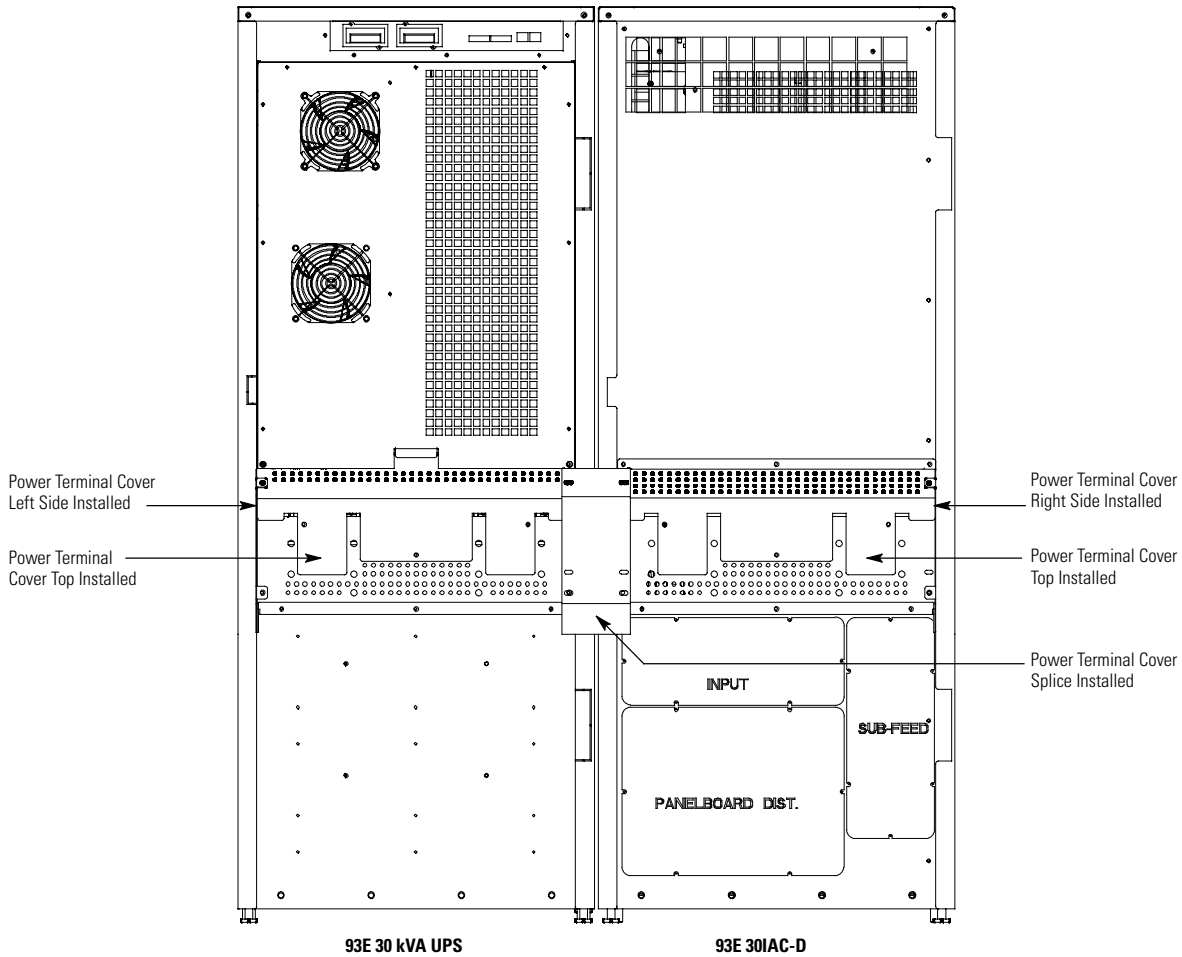

NOTE 1 The 93E 30IAC-D and 93E 30 kVA UPS are shown. The 93E 60IAC-D and 93E 60 kVA UPS installation is the same.

NOTE 2 The UPS and IAC-D are shown adjacent, but other installed accessory cabinets may be adjacent in large systems with multiple cabinets. However, the cover splice installation is the same.

NOTE 3 Do not install the Power Terminal Cover Left and/or Right Side covers if wiring adjacent cabinets using the power terminal base wiring channel.

Figure 4-16. IAC-D Power Terminal Cover Splice Installation

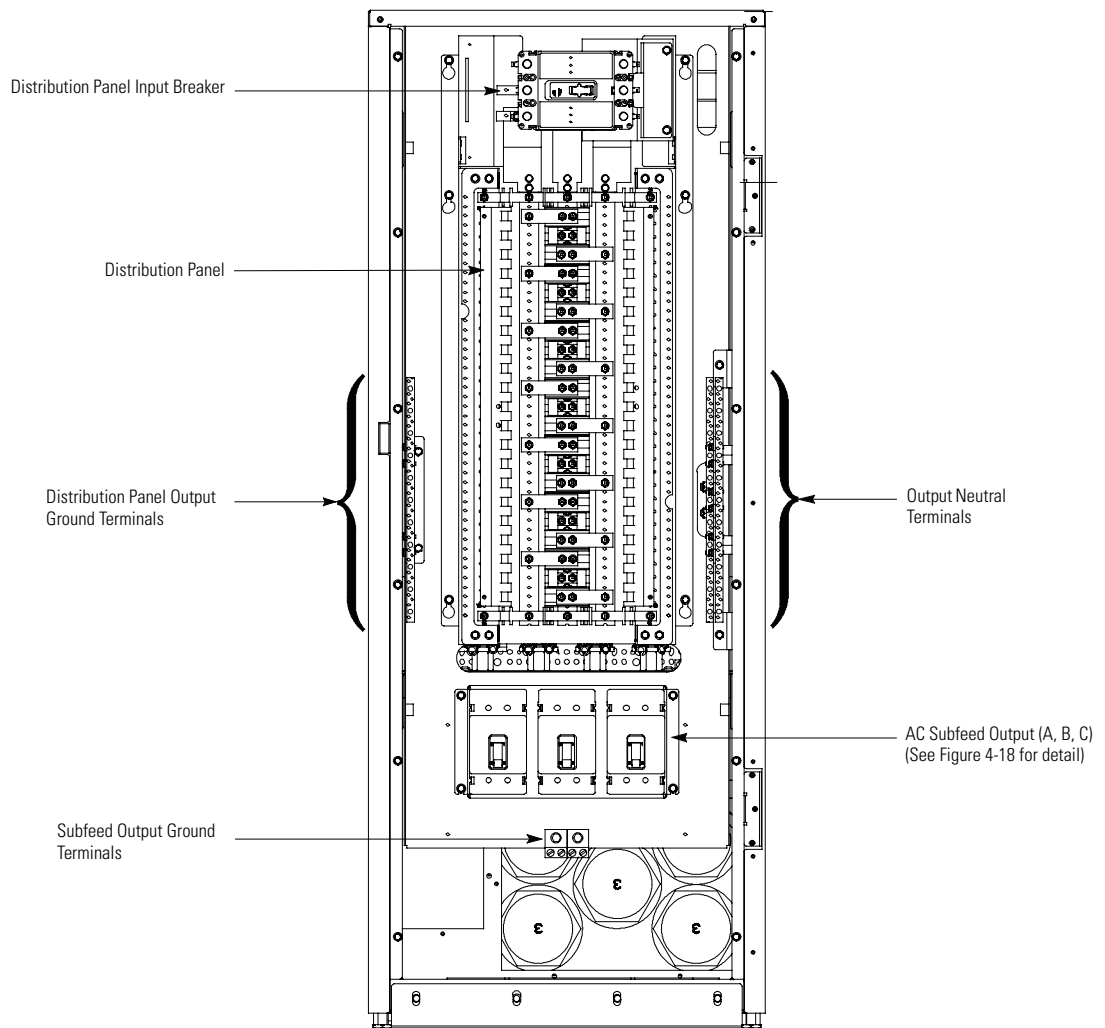

Figure 4-17. Output Power Terminal Locations

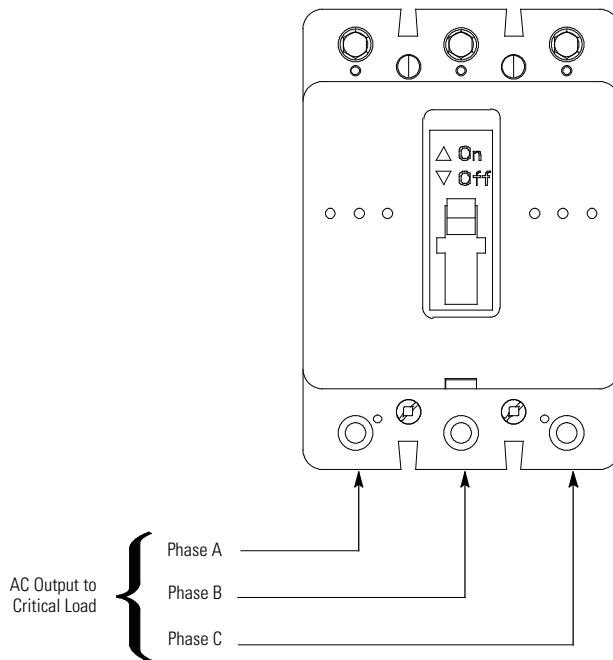

Figure 4-18. Subfeed Output Terminal Location– 93E 30IAC-D and 93E 60IAC-D

4.5 Initial Startup

Startup and operational checks must be performed by an authorized Eaton Customer Service Engineer, or the warranty terms specified on page W-1 become void. This service is offered as part of the sales contract for the UPS. Contact an Eaton service representative in advance (usually a two-week notice is required) to reserve a preferred startup date.

4.6 Completing the Installation Checklist

The final step in installing the IAC-D is completing the following Installation Checklist. This checklist ensures that you have completely installed all hardware, cables, and other equipment. Complete all items listed on the checklist to ensure a smooth installation. Make a copy of the Installation Checklist before filling it out, and retain the original.

After the installation is complete, an Eaton Customer Service Engineer must verify the operation of the UPS system and commission it to support the critical load. The service representative cannot perform any installation tasks other than verifying software and operating setup parameters. Service personnel may request a copy of the completed Installation Checklist to verify all applicable equipment installations have been completed.



NOTE

The Installation Checklist **MUST** be completed prior to starting the UPS system for the first time.

Installation Checklist

- All packing materials and restraints have been removed from each cabinet.
- The IAC-D is installed on a level floor suitable for computer or electronic equipment.
- The IAC-D is placed in its installed location
- The IAC-D is secured to the building floor or attached to the adjacent 93E system cabinet with the cabinet bracket
- All conduits and cables are properly routed between the IAC-D and the UPS.
- All power cables are properly sized and terminated.
- Distribution Panel branch circuit breakers are installed and wired to load.
- A ground conductor is properly installed.
- All terminal cover plates are installed.
- Air conditioning equipment is installed and operating correctly.
- The area around the UPS system is clean and dust-free.
- Adequate workspace exists around the IAC-D and other cabinets.
- Adequate lighting is provided around all IAC-D and UPS equipment.
- A 120 Vac service outlet is located within 7.5 meters (25 feet) of the IAC-D and UPS equipment.
- Startup and operational checks are performed by an authorized Eaton Customer Service Engineer.

Section 2

Operation

Chapter 5 Onelines and Schematics

5.1 Onelines

Figure 5-1 shows the simplified internal structure of the Integrated Accessory Cabinet-Distribution (IAC-D) and Figure 5-2 a simplified UPS, EBC, and IAC-D intercabinet connection diagram.

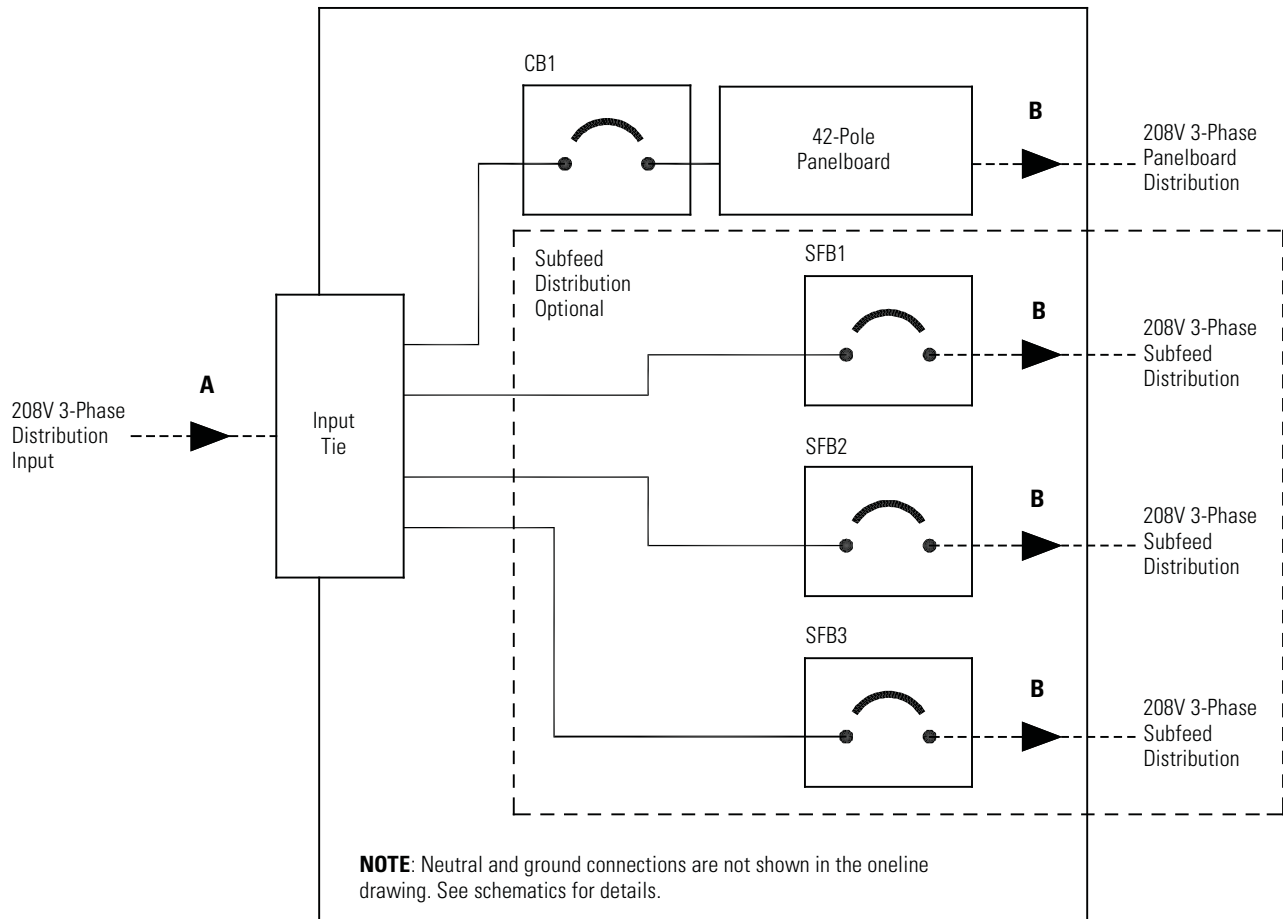

NOTE Callout letters **A** and **B** map to Table 3-3.

Figure 5-1. 93E 30IAC-D and 93E 60IAC-D Internal Oneline

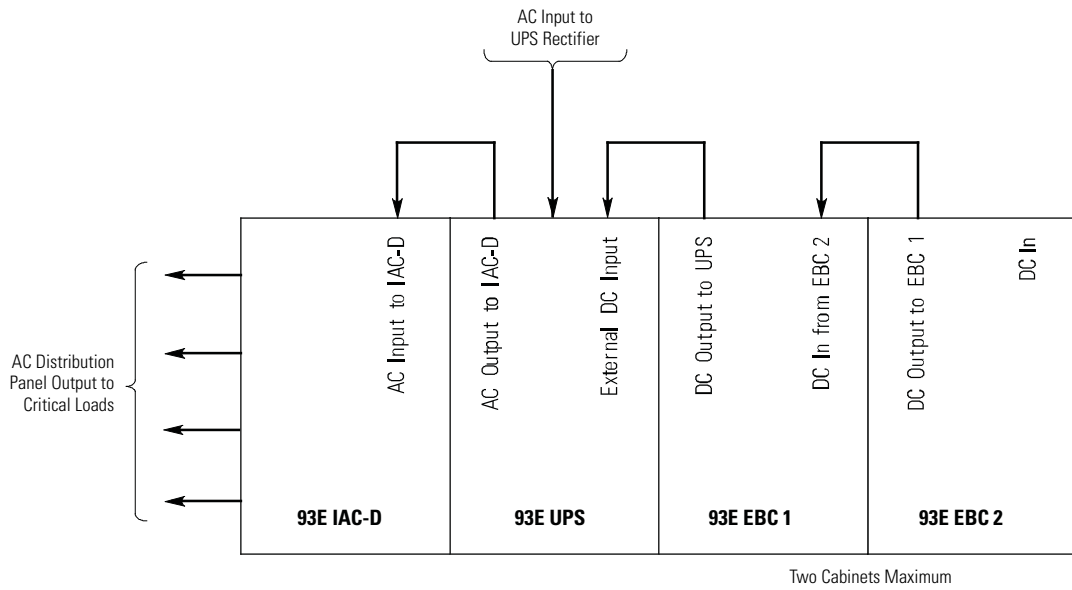

Figure 5-2. 93E 30IAC-D and 93E 60IAC-D Intercabinet Interconnection Online

5.2 Schematics

Figure 5-3 shows the IAC-D schematic.

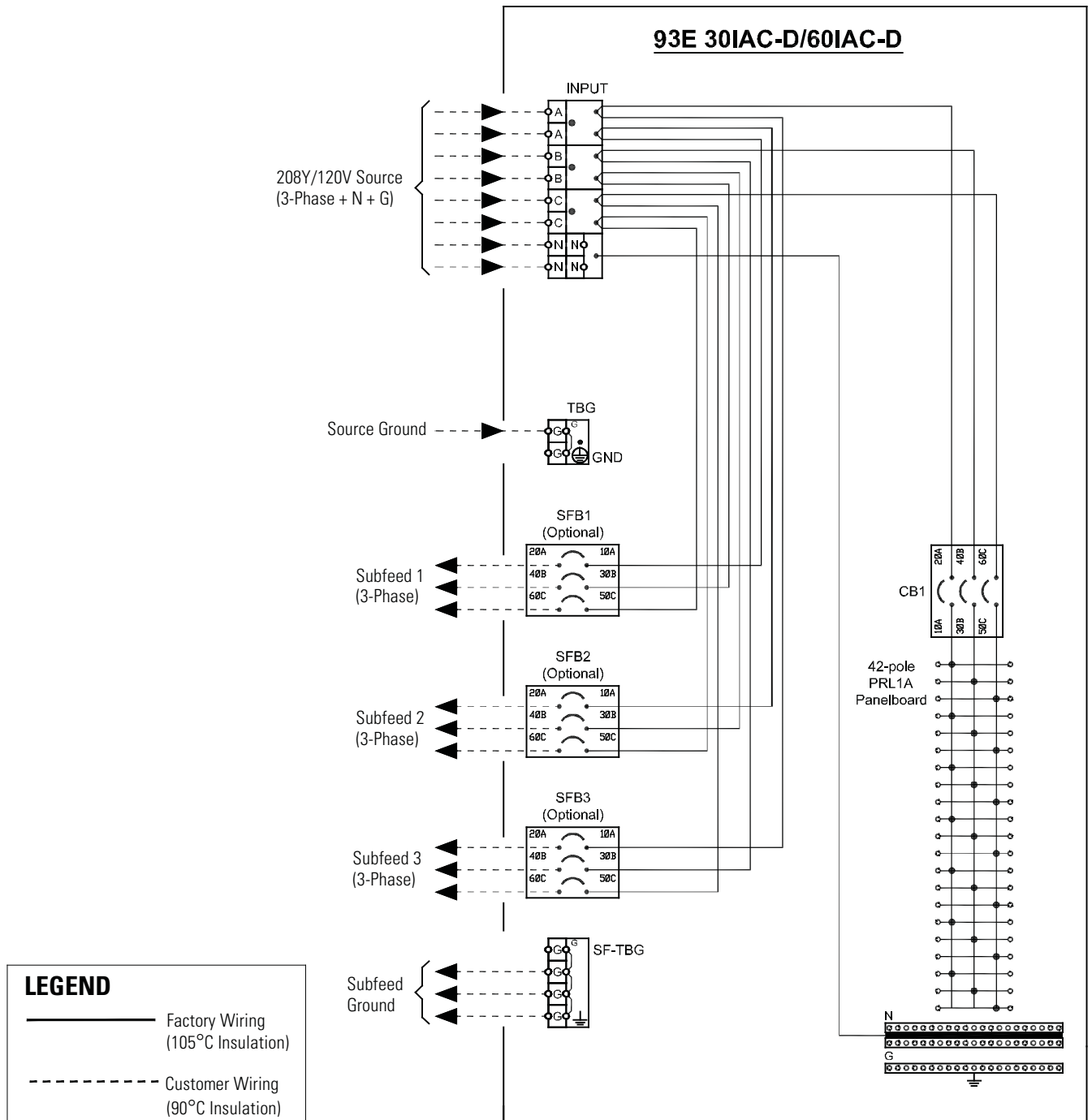

Figure 5-3. 93E 30IAC-D and 93E 60IAC-D Schematic

This page intentionally left blank.

Chapter 6 Integrated Accessory Cabinet-Distribution Operating Instructions

This section describes how to operate the Integrated Accessory Cabinet-Distribution (IAC-D).

NOTE 1 Before using the IAC-D, ensure all installation tasks are complete and a preliminary startup has been performed by authorized service personnel. The preliminary startup verifies all electrical interconnections to ensure the installation was successful and the system operates properly.



NOTE 2 Read this section of the manual and have thorough knowledge of IAC-D operation before attempting to operate any of the controls.

6.1 IAC-D Breakers

Figure 6-1 and Figure 6-2 identify and show the location of the breakers on the IAC-Ds. The descriptions provide a brief overview of the IAC-D breakers with standard and optional features.

The IAC-Ds can contain the following breakers:

- **Distribution Panel Input Breaker** – Controls input to the distribution panel
- **Distribution Panel** – Provides up to 42 branch circuits to distribute the output power to the loads
- **Subfeed Breakers** – Up to three optional subfeed breakers for high current loads

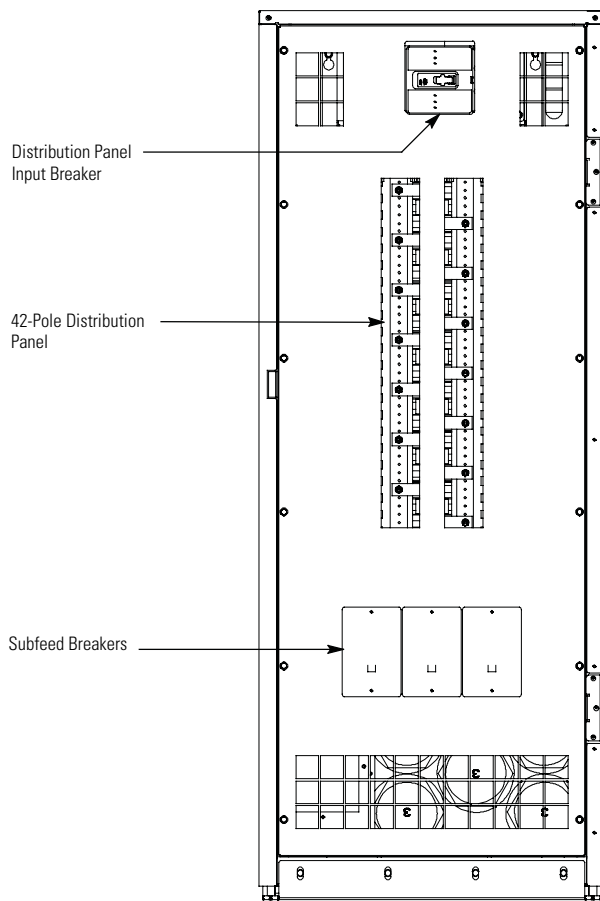

Figure 6-1. 93E 30IAC-D Breakers

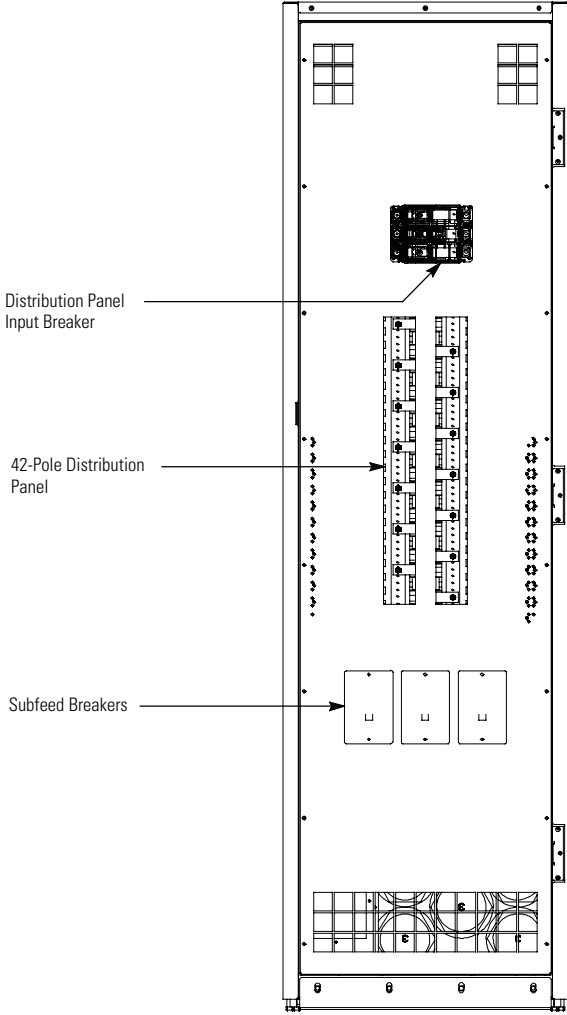

Figure 6-2. 93E 60IAC-D Breakers

6.2 IAC-D Operation

To operate the IAC-D:

1. Open the front door (see Figure 4-1) by lifting the latch from the bottom and turning to the right (counterclockwise) and swing the door open.
2. Verify that the IAC-D circuit breakers are set as follows:

| | |
|------------------------------------|-------------|
| Distribution Panel Input Breaker | OPEN |
| Distribution Panel Branch Breakers | OPEN |
| Subfeed Breakers (if installed) | OPEN |

3. Start the UPS. Refer to the applicable Eaton 93E UPS Installation and Operation manual listed in paragraph 1.7 for UPS operating procedures.
4. Close the distribution panel input breaker.
5. Close the distribution panel branch breakers
6. Close the subfeed breakers (if installed).
7. Close the door and secure the latch.

This page intentionally left blank.

Chapter 7 Maintenance

The components inside the IAC-D are secured to a sturdy metal frame. All repairable parts and assemblies are located for easy removal, with very little disassembly. This design allows authorized service personnel to quickly perform routine maintenance and servicing.

You must schedule periodic performance checks of the UPS system to keep it running properly. Regular routine checks of operation and system parameters enable your system to function efficiently for many trouble-free years.

7.1 Important Safety Instructions

Remember that your UPS system is designed to supply power **EVEN WHEN DISCONNECTED FROM THE UTILITY POWER.**

 **WARNING**

- No user serviceable components.
 - Servicing and maintenance should be performed by qualified service personnel only.
 - **LETHAL VOLTAGE PRESENT.** This unit should not be operated with the cabinet doors open or protective panels removed. Do not make any assumptions about the electrical state of any cabinet in the UPS system.
-

7.2 Performing Preventive Maintenance

The UPS system requires very little preventive maintenance. However, the system should be inspected periodically to verify that the units are operating normally. Record maintenance results and any corrective actions in a suitable log.

7.2.1 DAILY Maintenance

Perform the following steps daily:

1. Check the area surrounding the UPS system. Ensure the area is not cluttered, allowing free access to the unit.
2. Ensure the air intakes on the Accessory cabinets are not blocked.
3. Ensure the operating environment is within the parameters specified in paragraph 3.2.1 and Chapter 8, "Product Specifications."

7.2.2 PERIODIC Maintenance

Periodic inspections of the IAC-D should be made to determine if components, wiring, and connections exhibit evidence of overheating. Particular attention should be given to the compression lug connections. Maintenance procedures should specify that the compression lug connections be retorqued to values listed in this manual.

7.2.3 ANNUAL Maintenance

Annual preventive maintenance should be performed only by authorized service personnel familiar with maintenance and servicing of the UPS system. Contact an Eaton service representative for more information about service offerings.

7.3 Maintenance Training

A basic training course, available from Eaton Corporation, gives you a competent working knowledge of the UPS system operation and teaches you how to perform first level corrective maintenance. For more information about training and other services, contact the Help Desk (see paragraph 1.8).

This page intentionally left blank.

Chapter 8 Product Specifications

This section provides the following specifications:

- Model Numbers
- Input specifications
- Output specifications
- Environmental and safety specifications

8.1 Model Numbers

The Integrated Accessory Cabinet-Distribution (IAC-D) is available in two models to meet the needs of the Eaton 93E UPS product line.

| Integrated Accessory Cabinet-Distribution (IAC-D) Models | Description |
|---|--------------------------------|
| Eaton 93E 30 IAC-D | IAC-D for Eaton 93E 30 kVA UPS |
| Eaton 93E 60 IAC-D | IAC-D for Eaton 93E 60 kVA UPS |

8.2 Specifications

The following sections detail the input, output, and environmental and safety specifications for the IAC-D.

8.2.1 Input

| | |
|---|-------------------------|
| Operating Input Voltage Range | 208 Vac nominal (60 Hz) |
| Input Wiring: 4W + G Operating Frequency Range | 60 Hz \pm 5 Hz |
| Operating Input Current | See Table 3-3 |

8.2.2 Output

| | |
|---|---------------------|
| Operating Output Voltage | 208/120 Vac nominal |
| Output Wiring: 4W + G Operating Output Frequency Range | 60 Hz \pm 5 Hz |
| Output Current | See Table 3-3 |

8.2.3 Environmental and Safety Specifications

| | |
|--|--|
| Operating Temperature | 32°F to 86°F (0°C to 30°C). |
| Transit Temperature | -13°F to 140°F (-25°C to 60°C) |
| Storage Temperature | -13°F to 131°F (-25°C to 55°C) |
| Operating Altitude | Maximum 1000m (3280 ft) at 30°C without derating |
| Transit Altitude | 15000m (49213 ft) |
| Ventilation | Convection |
| Relative Humidity (operating and storage) | 5% to 95% maximum noncondensing |
| Acoustical Noise | Not applicable |
| Safety Conformance | UL1778 4 th edition |
| Agency Markings | ULus |
| EMC (Class A) | FCC Part 15 Class A and 62040-2 c3 |

Warranty

LIMITED FACTORY WARRANTY FOR THREE-PHASE EATON® 93E UPS AND 93E UPS ACCESSORY PRODUCTS

WARRANTOR: The warrantor for the limited warranties set forth herein is Eaton Corporation, an Ohio Corporation ("Eaton").

LIMITED WARRANTY: This limited warranty (this "Warranty") applies only to the original end-user (the "End-User") of the Eaton Three-Phase 93E UPS and 93E UPS Accessory Products (the "Product") and cannot be transferred. This restriction applies even in the event that the Product is initially sold by Eaton for resale to an End-User. This Warranty gives you specific legal rights, and you may also have other rights which vary from State to State (or jurisdiction to jurisdiction).

WHAT THIS LIMITED WARRANTY COVERS: The warrantor warrants, with the terms of this Warranty, that the Eaton three-phase UPS electronics, Eaton-built accessories, and Eaton-built battery cabinets (individually and collectively, the "Warranted Items") are free from defects in material and workmanship.

For Product installed (and currently located) in the fifty (50) United States and the District of Columbia, if, in the opinion of Eaton, a Warranted Item is defective, Eaton's sole obligation, at the option of Eaton, will be to refurbish or replace such defective Warranted Item (including the costs of providing diagnosis, service, and labor ["labor coverage"]). The defective Warranted Item will be refurbished or replaced onsite at the End-User's location or such other location as determined by Eaton. Any parts that are replaced may be new or reconditioned. All parts replaced by Eaton shall become the property of Eaton.

For Product installed (and currently located) outside the fifty (50) United States and the District of Columbia, if, in the opinion of Eaton, a Warranted Item is defective, Eaton's sole obligation, at the option of Eaton, will be to refurbish or replace such defective Warranted Item (not including the costs of labor coverage). The defective Warranted Item will be refurbished or replaced onsite at the End-User's location or such other location as determined by Eaton. Any parts that are replaced may be new or reconditioned. All parts replaced by Eaton shall become the property of Eaton.

LIMITED WARRANTY PERIOD: The period covered by this Warranty for Product installed (and currently located) in the fifty (50) United States and the District of Columbia is six (6) months from the date of Product purchase for labor coverage when no startup is performed by an authorized Eaton Customer Service Engineer or Agent or twelve (12) months from the date of Product purchase with startup performed by an authorized Eaton Customer Service Engineer or Agent and twelve (12) months from the date of Product purchase or eighteen (18) months from date of Product shipment, whichever occurs first, for the refurbishment/ replacement of parts.

The period covered by this Warranty for Product installed (and currently located) outside the fifty (50) United States and the District of Columbia is twelve (12) months from the date of Product purchase or eighteen (18) months from the date of Product shipment, whichever occurs first, for the refurbishment/replacement of parts.

WHAT THIS LIMITED WARRANTY DOES NOT COVER: This Warranty does not cover any defects or damages caused by: (a) failure to properly store the Product before installation, including the "trickle charge" of batteries no later than the date indicated on the packaging; (b) shipping and delivery of the Product if shipping is FOB Factory; (c) neglect, accident, fire, flood, lightning, vandalism, acts of God, Customer's neglect, abuse, misuse, misapplication, incorrect installation; (d) repair or alteration not authorized in writing by Eaton personnel or performed by an authorized Eaton Customer Service Engineer or Agent; or (e) improper testing, operation, maintenance, adjustment, or any modification of any kind not authorized in writing by Eaton personnel or performed by an authorized Eaton Customer Service Engineer or Agent.

This Warranty is not valid: if the Product's serial numbers have been removed or are illegible. Any Warranted Items repaired or replaced pursuant to this Warranty will be warranted for the remaining portion of the original Warranty subject to all the terms thereof. Eaton does not provide a labor warranty for Product located outside of the fifty (50) United States or the District of Columbia. **Any equipment, parts, or materials included in the Product and not manufactured by Eaton are warranted solely by the manufacturer of such equipment, parts, or materials and are not included as part of this Warranty. Batteries are not warranted by Eaton.**

THIS WARRANTY IS THE END-USER'S SOLE REMEDY AND IS EXPRESSLY IN LIEU OF, AND THERE ARE NO OTHER, EXPRESSED OR IMPLIED GUARANTEES OR WARRANTIES (INCLUDING ANY IMPLIED WARRANTY OF MERCHANTABILITY OR FITNESS FOR ANY PURPOSE, WHICH ARE EXPRESSLY DISCLAIMED). SOME STATES OR JURISDICTIONS DO NOT ALLOW THE EXCLUSION OF EXPRESS OR IMPLIED WARRANTIES, SO THE ABOVE EXCLUSION MAY NOT APPLY TO YOU. IN THAT EVENT, SUCH WARRANTIES ARE LIMITED IN DURATION TO THE LIMITED WARRANTY PERIOD. SOME STATES OR JURISDICTIONS DO NOT ALLOW LIMITATIONS ON HOW LONG AN IMPLIED WARRANTY LASTS OR THE EXCLUSION OR LIMITATION OF INCIDENTAL OR CONSEQUENTIAL DAMAGES, SO THE ABOVE LIMITATIONS AND/OR EXCLUSIONS MAY NOT APPLY TO YOU.

LIMITATION OF LIABILITY: In no event shall Eaton be liable for any indirect, incidental, special or consequential damages of any kind or type whatsoever, resulting from or in connection with any claim or cause of action, whether brought in contract or in tort (including negligence and strict liability). Some States or jurisdictions do not allow the exclusion of limitation of incidental or consequential damages, so the above limitation or exclusion may not apply to you. Eaton shall not be responsible for failure to provide service or parts due to causes beyond Eaton's reasonable control. In no case will Eaton's liability under this Warranty exceed the replacement value of the Warranted Items.

END-USER'S OBLIGATIONS: In order to receive the benefits of this Warranty, the End-User must register the product warranty (via mail or online at www.powerquality.eaton.com/Product-Registration "product registration"); use the Product in a normal way; follow the Product's user's guide; and protect against further damage to the Product if there is a covered defect.

OTHER LIMITATIONS: Eaton's obligations under this Warranty are expressly conditioned upon receipt by Eaton of all payments due to it (including interest charges, if any). During such time as Eaton has not received payment of any amount due to it for the Product, in accordance with the contract terms under which the Product is sold, Eaton shall have no obligation under this Warranty. Also during such time, the period of this Warranty shall continue to run and the expiration of this Warranty shall not be extended upon payment of any overdue or unpaid amounts.

COSTS NOT RELATED TO WARRANTY: The End-User shall be invoiced for, and shall pay for, all services not expressly provided for by the terms of this Warranty, including without limitation site calls involving an inspection that determines no corrective maintenance is required. Any costs for replacement equipment, installation, materials, freight charges, travel expenses, or labor of Eaton representatives outside the terms of this Warranty will be borne by the End-User.

OBTAINING WARRANTY SERVICE: In the USA, call the Eaton Customer Reliability Center 7x24 at 800-843-9433. Outside of the USA, call your local Eaton sales or service representative, or call the Eaton Customer Reliability Center in the United States at 919-845-3633. For comments or questions about this Limited Factory Warranty, write to the Customer Quality Representative, 8609 Six Forks Road, Raleigh, North Carolina 27615 USA.



P-16400072 2